

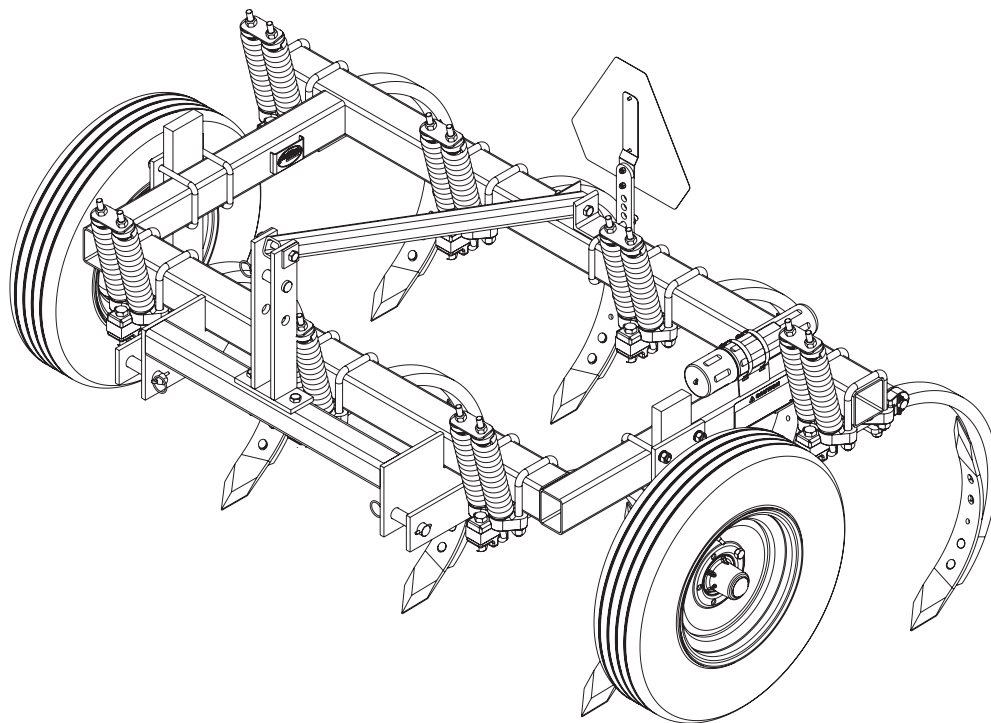

2-Bar Pick-Up Chisel Plow
Models: CPPR2-5, CPPR2-7,
CPPS2-5, CPPS2-7
Operator's and Parts Manual



LANDOLL COMPANY, LLC

1900 North Street

Marysville, Kansas 66508

(785) 562-5381

800-428-5655 ~ WWW.LANDOLL.COM

Instructions for Ordering Parts

**** Repair parts must be ordered through an Authorized Dealer ****

DEALER INSTRUCTIONS FOR ORDERING PARTS FROM LANDOLL PARTS DISTRIBUTION CENTER

Phone #: 800-423-4320 or 785-562-5381

Fax #: 888-527-3909

Order online: dealer.landoll.com

IDENTIFICATION PLATE

The identification plate, which lists the model and serial number of the equipment. It is located on the rear right, inside frame of the Chisel Plow.

SERIAL NUMBER NOMENCLATURE

The serial number for the Chisel Plow is located on the identification plate. The following information will help decode the Landoll serial number.

CPD2400100 = xxmysssss

xx	= model series (i.e. "CP" for all Chisel Plows)
m	= month of manufacture (ex. "D" means April. The letter I is not used.)
yy	= year manufactured (ex. "24" means 2024)
sssss	= Sequential number used to track warranty and service information.

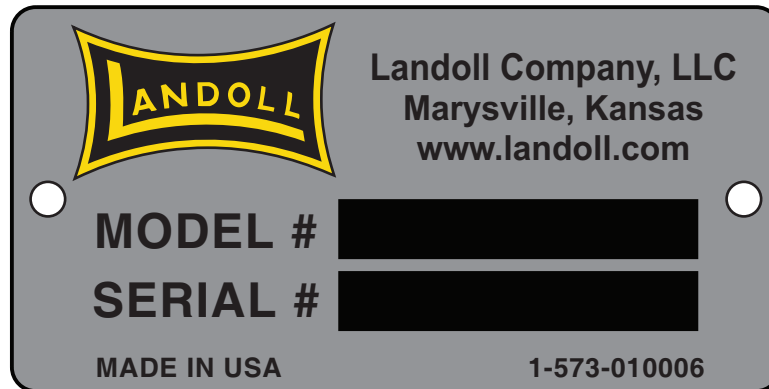

Identification Plate

Manuals for 2-Bar Pick-Up Chisel Plow

Manual Number	Manual Type
9D990	Operator's and Parts Manual



DANGER

DO NOT operate or perform any maintenance tasks on this equipment until you have completed the following:

- 1. Receive proper training to operate this equipment safely.**
- 2. Read and understand the operator's manual.**
- 3. Be thoroughly trained on inspection and repair procedures.**

Failure to comply with this warning may result in serious injury or possibly death.

Table of Contents

1 Safety Information

Introduction	1-1
Description of Unit	1-1
Using this Manual	1-1
Owner Assistance	1-1
Warranty Registration	1-1
Safety	1-2
Understanding Safety Statements	1-2
Transporting Safety	1-2
Safety Instructions for Towing Vehicles	1-3
Attaching, Detaching and Storage	1-3
Maintenance Safety	1-3
Protective Equipment	1-3
Tire Safety	1-3
Prepare for Emergencies	1-3

2 Assembly

Main Frame Assembly	2-2
Manual Storage Canister	2-2
SMV Sign	2-2
Shank Installation	2-4
Shank Mounting Dimensions	2-4
Spring Clamp Shank Assembly	2-6
Rigid Clamp Shank Assembly	2-6
Point Installation	2-7
Chisel Plow Point	2-7
Twisted Shovels	2-7
Gauge Wheel Assembly	2-8

3 Operating Instructions

General	3-1
Operating Tips	3-1
Operating Speed	3-1
Tractor Preparation	3-2
Attaching to 3-PT Hitch	3-2
Field Operation	3-2
Spring Shank Tension Adjustment	3-2
Transport	3-3

4 Maintenance

General Torque Specifications 4-1
 Fasteners 4-2
 Tires 4-2
 Points 4-2
 Lubrication Maintenance 4-2
 Storage 4-3

5 Specifications

6 Illustrated Parts List

Frame 6-1
 Rigid Shank Assembly 6-2
 Shank and Spring Clamp Assembly 6-3
 Spring Shank Assembly 6-4
 Points 6-6
 SMV Assembly 6-7
 Gauge Wheel Kit (Optional) 6-8
 Hub and Spindle Assembly 6-9
 Wheel Assembly 6-10
 Decals 6-11
 Decal Locations 6-12

7 Glossary

8 Index

Safety Information

Introduction

The implement described in this manual has been designed with care and built by skilled workers using quality materials and processes. Proper assembly, maintenance and safe operation will allow this machine to provide you with satisfactory use for seasons to come.



DANGER

Read this entire manual before attempting to assemble, adjust or operate this machine. Failure to comply with this warning can result in personal injury or death, damage to the machine or its components and inferior operation.

Description of Unit

The Chisel Plow was the machine that started the age of “conservation tillage” as we know it today. The 2-Bar Chisel Plow offers an effective and economic solution to basic primary tillage. A wide variety of shank configurations and points allow the producer to fine tune the Chisel Plow to fit his requirements.

Using this Manual

This manual will familiarize you with safety, assembly, operation, adjustment and maintenance. Read this manual and follow the recommendations to help ensure safe and efficient operation.

- The information in this manual is current at the time of printing. Some parts may change to assure peak performance.
- Location reference: Right and Left designations in this manual are determined by facing the direction the implement will travel during field operation, unless otherwise stated.

Owner Assistance

If customer service or repairs are needed, contact your Brillion dealer. They have trained personnel, parts, and service equipment specially designed for Brillion products. Your implement’s parts should only be replaced with Brillion parts. If items covered in this manual are not understood, contact your local Brillion dealer.

Warranty Registration

Brillion Farm Equipment, by Landoll, shall have no warranty obligation unless each product is registered, within 10 days of retail purchase, using the Landoll Company, LLC Ag Products on-line registration process. Please refer to the Ag Products Policy and Procedures Manual, accessible at www.landoll.com for step by step instructions regarding product registration.

Enter your product information below for quick reference. Refer to the ID plate as shown. **See Figure 1-1.**

MODEL NUMBER

SERIAL NUMBER

DATE OF PURCHASE

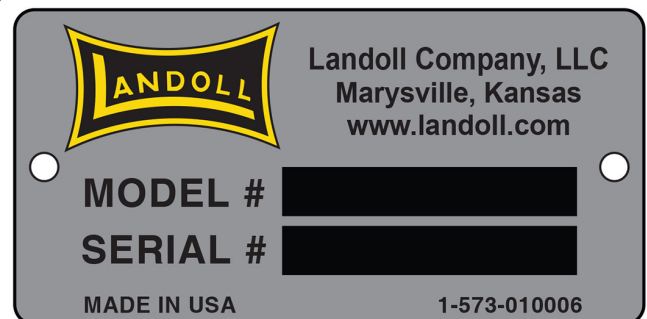

Figure 1-1: ID Plate

SAFETY INFORMATION

Safety

NOTE

Investigation has shown that nearly 1/3 of all farm accidents are caused by careless use of machinery. Insist that all people working with you or for you abide by all safety instructions.

Understanding Safety Statements

You will find various types of safety information on the following pages and on the implement decals (signs) attached to the implement. This section explains their meaning.

NOTICE

Special notice - read and thoroughly understand.

CAUTION

Proceed with caution. Failure to heed caution may cause injury to person or damage product.

WARNING

Proceed with caution. Failure to heed warning will cause injury to person or damage product.

DANGER

Proceed with extreme caution. Failure to heed notice will cause injury or death to person and/or damage product.

NOTE

You should read and understand the information contained in this manual and on the implement decals before you attempt to operate or maintain this equipment.

- Examine safety decals and be sure you have the correct safety decals for the implement. See “Decals” on page 6-11.
- Order replacement decals through your Brillion dealer.
- Keep these signs clean so they can be observed readily. It is important to keep these decals cleaned more frequently than the implement. Wash with soap and water or a cleaning solution as required.

- Replace decals that become damaged or lost. Also, be sure that any new implement components installed during repair include decals which are assigned to them by the manufacturer.
- When applying decals to the implement, be sure to clean the surface to remove any dirt or residue. Where possible, sign placement should protect the sign from abrasion, damage, or obstruction from mud, dirt, oil etc.



DANGER

- Do not allow anyone to ride on the tractor or implement. Riders could be struck by foreign objects or thrown from the implement.
- Never allow children to operate equipment.
- Keep bystanders away from implement during operation.

Transporting Safety

IMPORTANT

It is the responsibility of the owner/operator to comply with all state and local laws.

- When transporting the implement on a road or highway, use adequate warning symbols, reflectors, lights and slow moving vehicle sign as required. Slow moving tractors and towed implements can create a hazard when driven on public roads. They are difficult to see, especially at night.
- Do not tow an implement that, when fully loaded, weighs more than 1.5 times the weight of the towing vehicle.
- Carry reflectors or flags to mark the tractor and implement in case of breakdown on the road.
- Do not transport at speeds over 20 MPH under good conditions. Never travel at a speed which does not allow adequate control of steering and stopping. Reduce speed if towed load is not equipped with brakes.
- Avoid sudden stops or turns because the weight of the implement may cause the operator to lose control of the tractor. Use a tractor heavier than the implement.
- Use caution when towing behind articulated steering tractors; fast or sharp turns may cause the implement to shift sideways.
- Keep clear of overhead power lines and other obstructions when transporting. Know the transport height and width of your implement. See “General Torque Specifications” on page 4-1.

Safety Instructions for Towing Vehicles

The maximum travel speed is the lesser of

- The limit of the road conditions;
- The maximum specified ground speed;
 - for towing operations as indicated in this manual or SIS;
 - of the towed vehicle as indicated in its operator's manual, SIS, or information sign;
- The maximum ground speed of the towed equipment combination shall be limited to the lowest specified ground speed of any of the towed machines. This speed is the ground speed limitation.

EXAMPLE: If the tractor is capable of 25 mph, the first implement has a SIS for 19 mph, and the last implement's operator's manual states its specified ground speed is 15 mph, the towed equipment combination ground speed limitation is 15 mph.

Attaching, Detaching and Storage

- Do not stand between the tractor and implement when attaching or detaching implement unless both are incapable of moving.

Maintenance Safety

- Do not make adjustments or lubricate the machine while it is in motion or in the raised position.
- Make sure all moving parts have stopped.
- Understand the procedure before doing the work. Use proper tools and equipment.

Protective Equipment

- Wear protective clothing and equipment appropriate for the job. Avoid loose fitting clothing.
- Because prolonged exposure to loud noise can cause hearing impairment or hearing loss, wear suitable hearing protection, such as earmuffs or earplugs.

Tire Safety

Tire changing can be dangerous and should be performed by trained personnel using correct tools and equipment.

When inflating tires, use a clip-on chuck and extension hose long enough to allow you to stand to one side, not in front of or over the tire assembly. Use a safety cage if available.

When removing and installing wheels use wheel-handling equipment adequate for the weight involved.

Prepare for Emergencies

- Keep a First Aid Kit and Fire Extinguisher handy
- Keep emergency numbers for doctor, ambulance, hospital and fire department near phone.

**CAUTION**

Do not work on or under this machine unless securely blocked and supported by a hoist or tractor or by other sufficient means.

**WARNING**

Do not attempt to lift heavy parts (such as the frame, rock shaft, and pull hitch) manually. Use a hoist or a fork lift to move these parts into position.

NOTE

Refer to the repair Parts Manual Chapter for identification of parts and for the approximate relationship of the parts in assembly. Your exact Pulverizer Model may vary slightly from the illustration.

To ensure the alignment of assemblies, leave the nuts loose until completion of final assembly. Use lock washers or flat washers as specified. Spread all cotter pins.

After completion of final assembly, tighten all nuts evenly to prevent misalignment, distortion or binding. Tighten all screws and nuts to the recommended torques.

IMPORTANT

- If pre-assembled parts or fasteners are temporarily removed, remember where they go. It is best to keep parts separated.
- Check that all working parts move freely, bolts are tight and cotter pins spread.
- Refer to the Torque Table for proper torque values. Note the different torque requirements for Bolts with Locknuts. **See "General Torque Specifications" on page 4-1.**

“Left” and “Right” refer to directions seen as if standing behind the machine and facing in the direction of forward travel.

Main Frame Assembly

Assembly of the Main Frame consists of attaching the Mast and Brace Tube.

1. Place the Frame on blocks at least 36-42 inches high for the assembly of the machine.
2. Bolt the Mast to the matching Hitch Tube Holes on the Frame with 5/8" x 4-1/2" Long Capscrews. **Do not tighten at this time.**
3. Fasten the ends of the Brace Tube between the upper holes in the Mast and between the two Angles on the rear of the Frame.
4. Place the two Machinery Bushings between the Brace Tube and Mast Uprights. **See Figure 2-2.**
5. Secure both ends of the Brace Tube to the Mast and Frame with 5/8" x 4" Long Capscrews, Lock Washers, and Nuts.
6. Tighten all hardware to the recommended torques. **See "General Torque Specifications" on page 4-1.**

Manual Storage Canister

Install the Manual Canister to the frame with Hose Clamps. **See Figure 2-2.**

SMV Sign

Attach the SMV Mount about 4 inches left of center on the rear Frame Tube with 5/8-11 U-Bolt and Locknuts. **See Figure 2-1.** Install SMV Sign to Mount with 5/16-18 x 1 Bolts, Flat Washers and Locknuts.

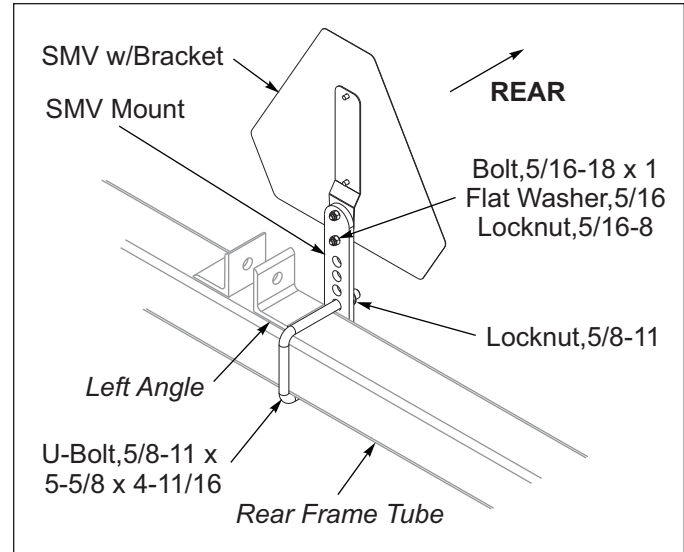

Figure 2-1: SMV Installation

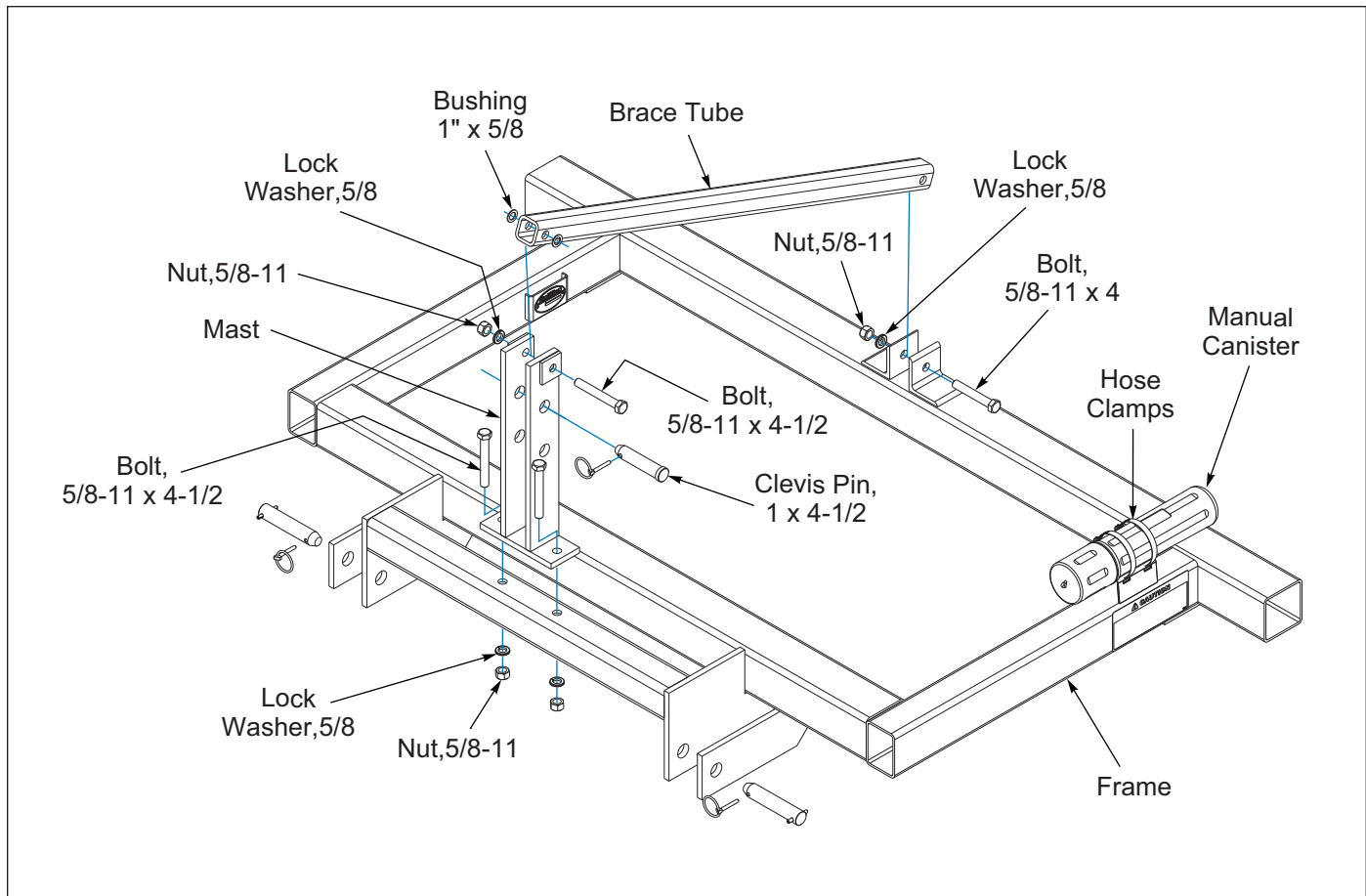

Figure 2-2: Main Frame Assembly

Shank Installation

Place the Frame on blocks at least 30 inches high for assembly of the Shanks.

Shank Mounting Dimensions

Mark the tubes for Shank locations prior to installing. See Figure 2-3 and 2-4.

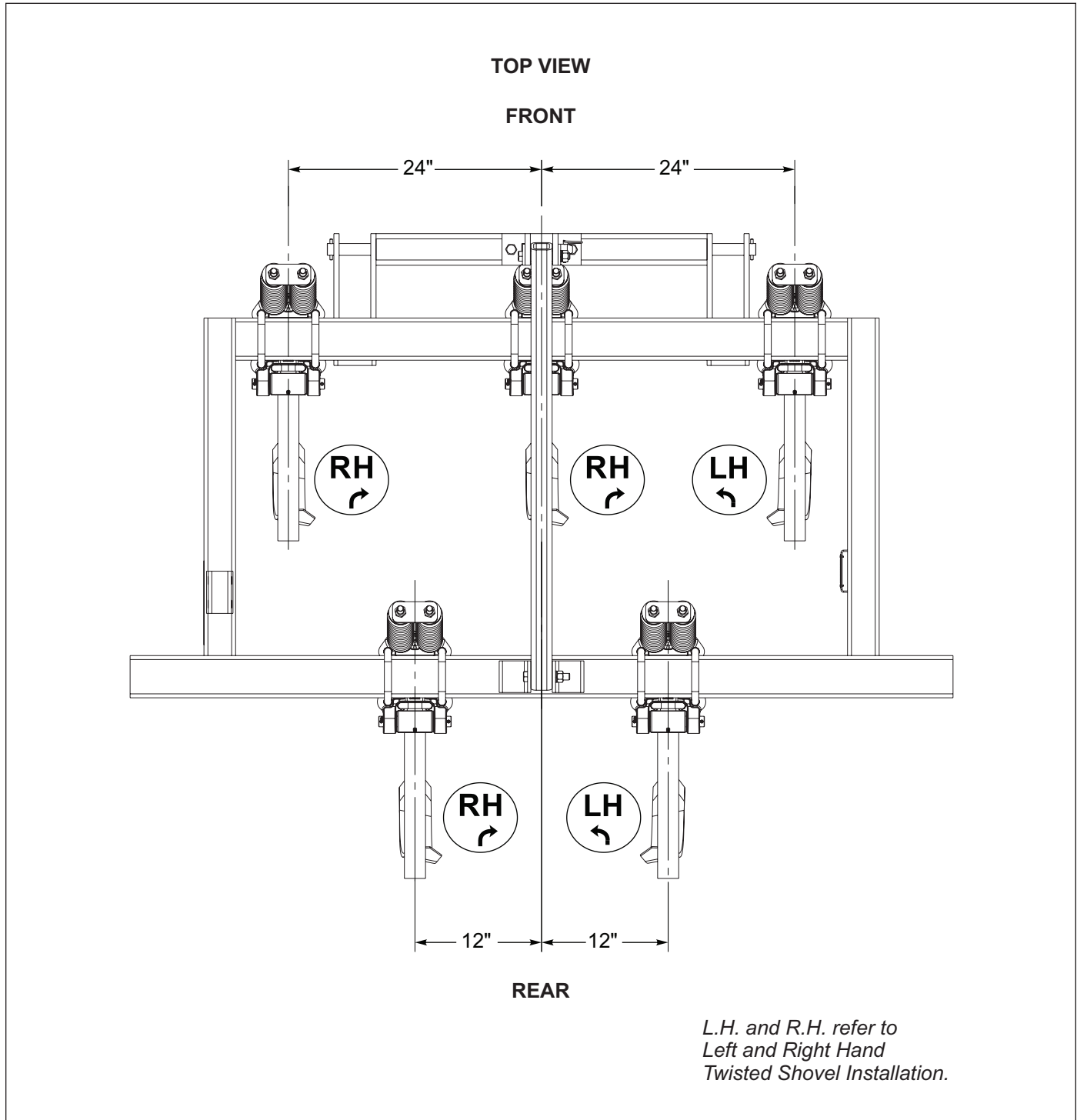

Figure 2-3: Shank Mounting Dimensions (5 Shank)

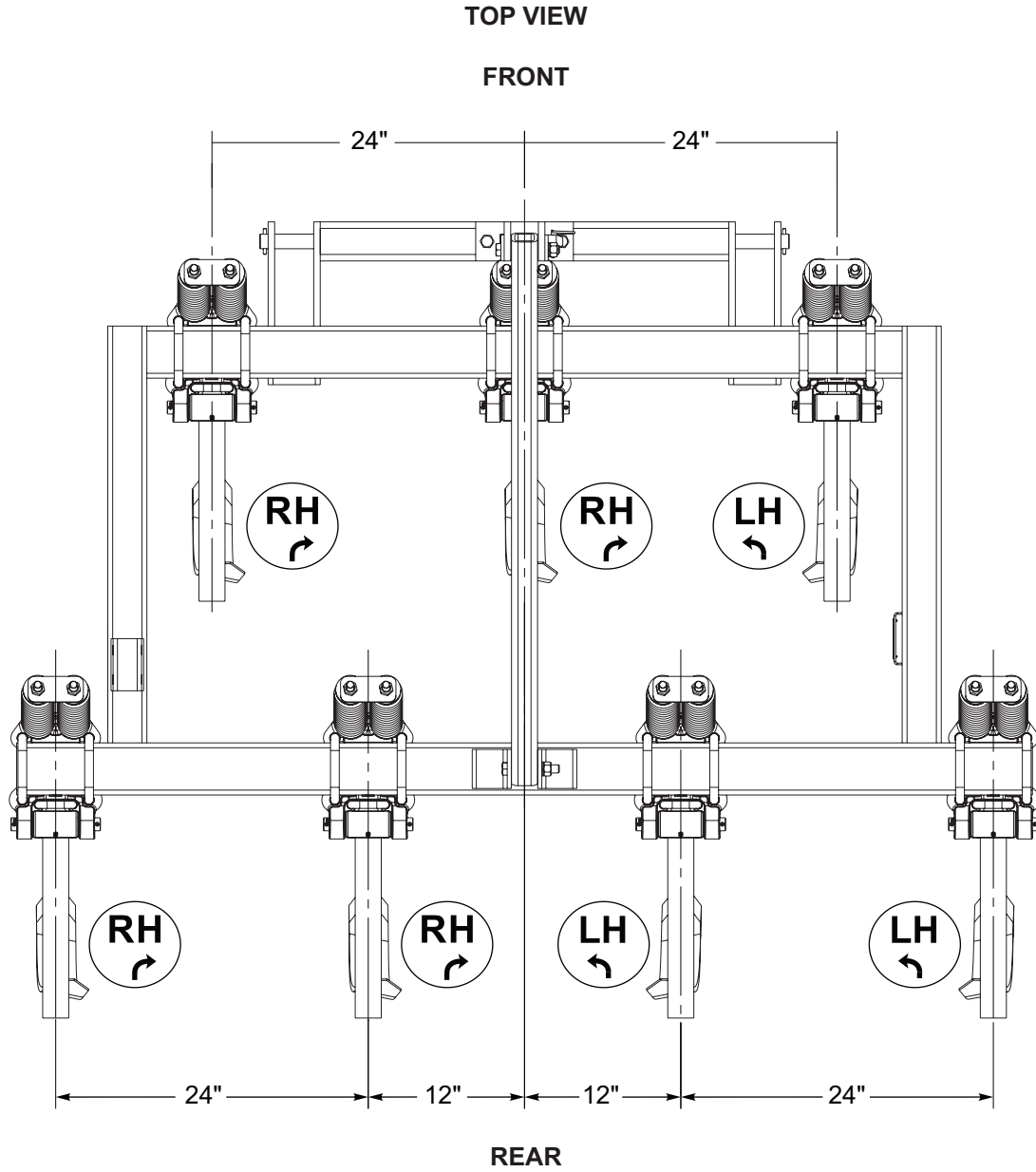

Figure 2-4: Shank Mounting Dimensions (7 Shank)

ASSEMBLY

Spring Clamp Shank Assembly

Remove the 3/4-10 U-Bolts, Lock Washers and Nuts. Place Shank Assembly Clamp under the frame and re-insert the U-Bolts over the top of the frame and through the Shank Assembly Clamp. Secure with Lock Washer and Nut. See Figure 2-5.

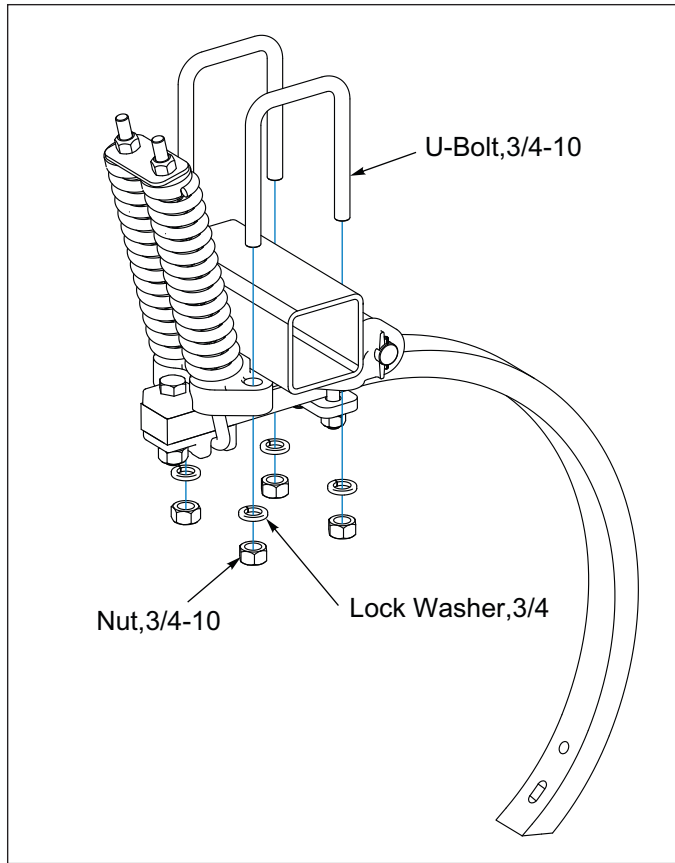

Figure 2-5: Spring Clamp Shank Assembly

Check the tension on the Shank Spring. For normal operation the Lock Nuts on the Spring mounting should be tightened so that one inch of thread is exposed. See Figure 2-6.

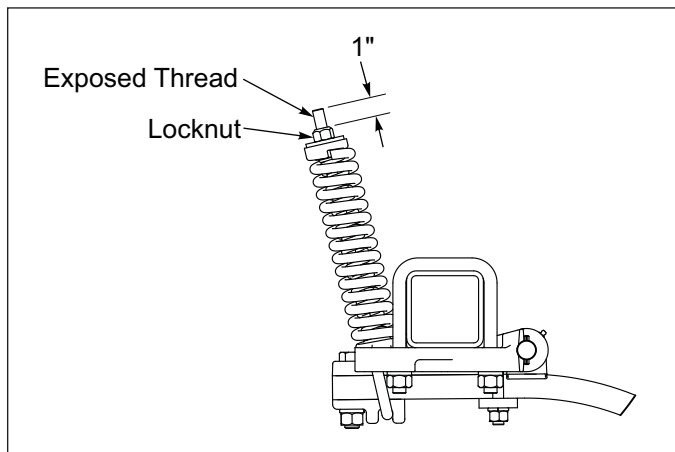

Figure 2-6: Spring Tension

Rigid Clamp Shank Assembly

Remove the front 3/4-10 x 7-1/2 Bolt, Lock Washer and Nut and loosen the 5/8-11 Nuts so that they are flush with the end of the Bolt. Slide the Shank Assembly onto the Frame Tube until the Shank Support seats on the bottom of the Frame Tube. Re-insert the 3/4-10 x 7-1/2 Bolt, Lock Washer and Nut and tighten the 5/8-11 Nuts. See Figure 2-7.

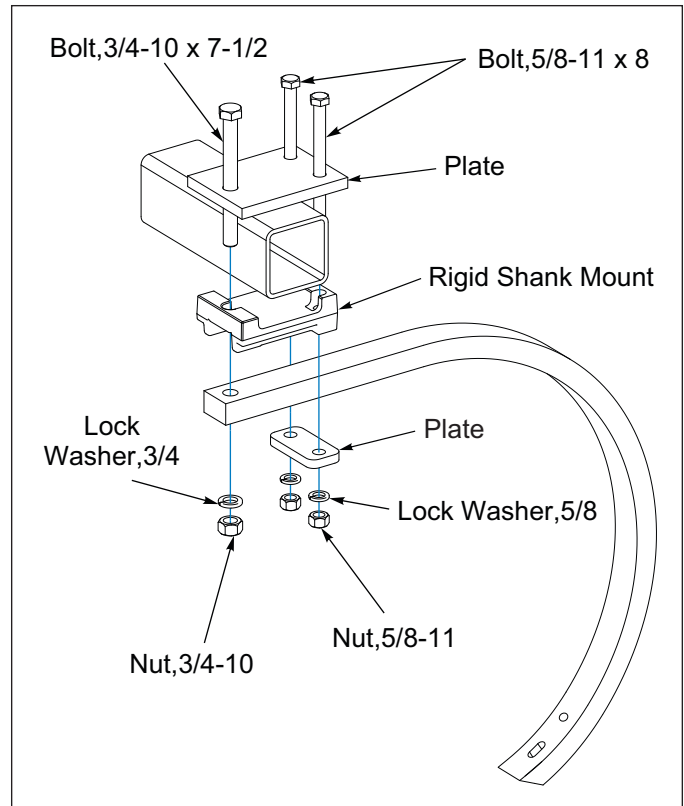

Figure 2-7: Rigid Clamp Shank Assembly

Point Installation

NOTE

When replacing or reversing point, change ALL points at the same time so that they will have the same operating depth. If some shanks have worn points and some have new points, or points of a different design, the chisel plow will not operate efficiently.

Chisel Plow Point

Install a Chisel Plow Point to each Shank with 1/2-13 x 3 Plow Bolts and Flanged Locknuts. See Figure 2-8.

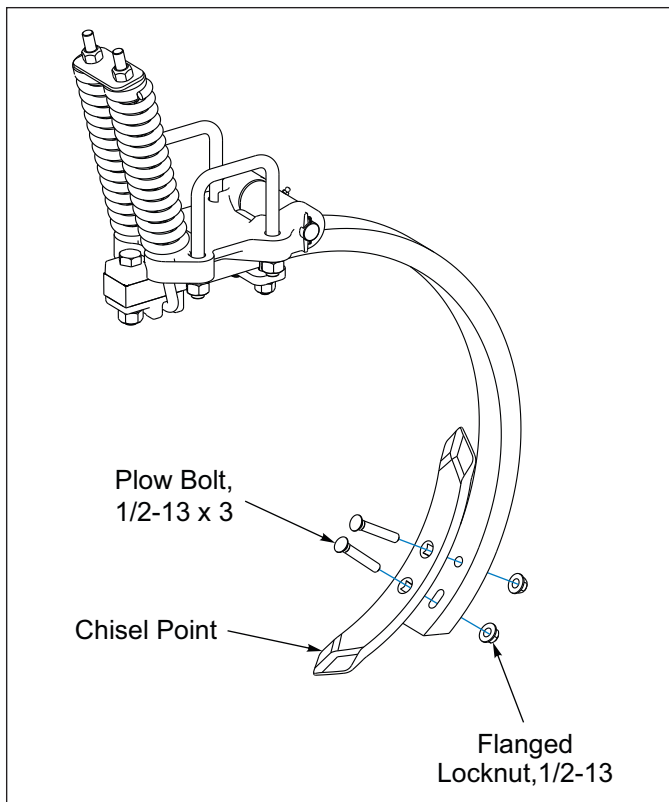

Figure 2-8: Chisel Plow Point

Twisted Shovels

Install a LH or RH Twisted Shovel per See Figure 2-3. to each Shank with 7/16-14 x 2-1/2 Special Plow Bolts and Flanged Lock Nuts. See Figure 2-9. LH means that the soil is thrown left and RH means that the soil is thrown right. If another arrangement is desired, be sure that the shovels have balanced positions from right side to left side. An example of this would be a LH shovel is the same distance from the center of the machine as a RH shovel is on the opposite side.

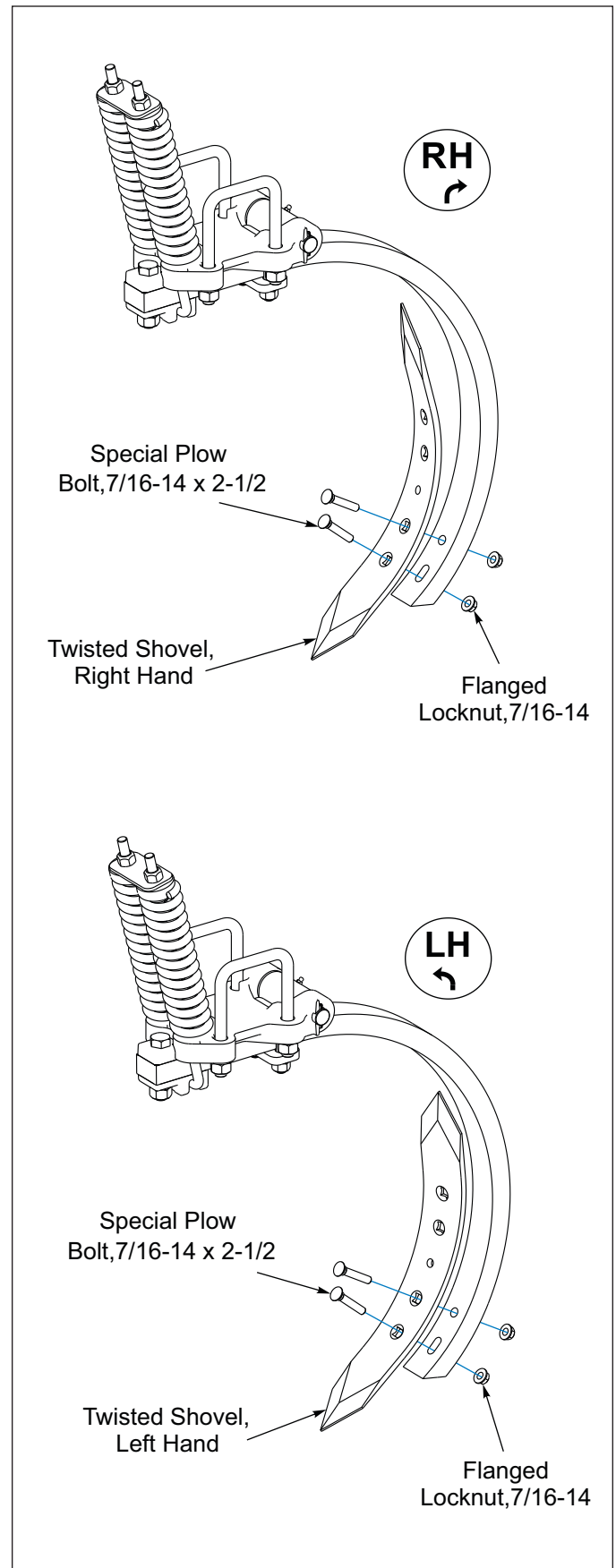

Figure 2-9: Twisted Shovels

ASSEMBLY

Gauge Wheel Assembly

1. Set the Frame on a level surface with the Shanks mounted.
2. Attach the Hub and Spindle Assembly to the Arm Weldment.
3. Clamp the Arm Weldment to the side bar of the Frame with 5/8 U-Bolts, Washer and Nuts. **See Figure 2-10.**
4. Position the Arm Weldment assembly about 1/3 of the way back from the front of the Frame. To adjust the
5. Gauge Wheels for depth, loosen the two U-Bolts but do not remove the nuts.
6. Set Gauge Wheels to desired height so that both Wheels are set at the same depth. The distance from the bottom of the tire to the tip of the Shank will be the approximate working depth of the Shank.
6. Tighten the U-Bolts securely and check periodically for looseness.

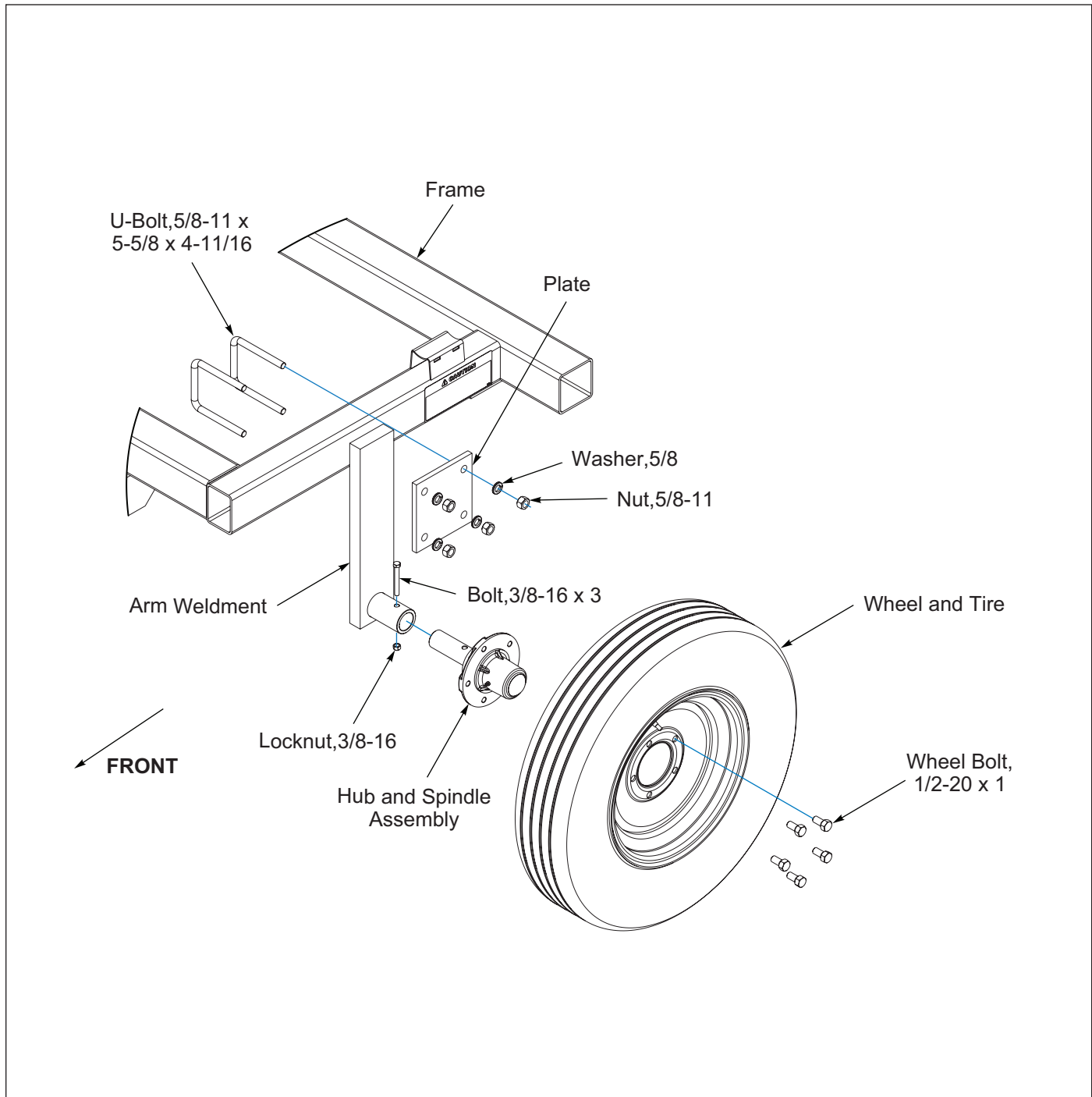

Figure 2-10: Gauge Wheel Installation

Operating Instructions



DANGER

Never allow anyone to ride on the Chisel Plow at any time. Allowing a person to ride on the machine can inflict serious personal injury or death to that person.



CAUTION

When transporting farm implements on public roads, it is the responsibility of the operator to abide by state and local laws concerning wide loads, speed, safety emblems and safety lighting equipment. Drive at safe speeds, particularly when rounding corners, crossing rough ground or driving on hillsides, to prevent tipping the tractor.

General

- The Chisel Plow loosens the soil to the desired depth, allowing water penetration into the soil. During the winter, the ground will freeze deeper and “weather out” much faster.
- Chisel plowing leaves a mulch and residue cover on the surface, preventing soil surface sealing. Water will be absorbed quickly into the soil, reducing runoff, evaporation and soil erosion. The residue cover also reduces wind erosion.

Operating Tips

- To retard downhill water movement on slopes, start at the bottom of the slope and work upwards, parallel to the bottom.
- Chisel the field at an angle to the rows to break up the ridges.

Operating Speed

- The chisel works best when operated at a relatively fast speed; 5 mph or faster. If field conditions are adverse, operate at a slower speed to reduce the possibility of implement damage.
- If field conditions are too rough to operate at high speed at the desired depth, make two passes at an angle to each other. Make the first pass shallower than the second pass.

NOTE

Before operating your Brillion machine, check all hardware for tightness. See "General Torque Specifications" on page 4-1.

Tractor Preparation

The Chisel Plow may be used on tractors equipped with CAT 2 Free Link or CAT 2, 3N Quick Coupler 3-PT Hitches. Before attaching the Chisel Plow, prepare the tractor as follows:

- a. The rear tractor tires should be inflated equally and ballast added according to the tractor operator's manual.
- b. Check that both lower lift arms are set to the same height.



CAUTION

Do not move the tractor without making sure top link is connected to tractor.

Attaching to 3-PT Hitch

1. Carefully back the tractor into place.
2. Attach the Chisel Plow to the tractor.
3. For tractors equipped with Quick Hitches:
 - a. Attach quick hitch to the Chisel Plow.
 - b. Raise and make sure lower pin locks are secured.
 - c. When disconnecting the Chisel Plow, adjust stands to leave the toolbar tilted slightly forward. This will permit easier disconnecting and reattaching.
4. For tractors not equipped with Quick Hitch:
 - a. Attach lower lift arms of the tractor to the Chisel Plow utilizing appropriate pins. Chisel Plow models come with either CAT 2 or CAT 3N NARROW hitches.
 - b. Attach top link after connecting lower lift arms. Park Chisel Plow on a firm level surface.
5. Reinstall the stabilizer bars or sway blocks before transporting.

Field Operation

1. Lower the Chisel Plow to the ground and pull it a few feet at the approximate desired depth.
2. Check for front-to-rear levelness. Level the frame by adjusting the 3-PT Hitch Top Link until the frame is level to the ground.
 - a. Set shank depth by adjusting the max depth stop on the 3-Point Control in the tractor.
 - b. Set shank depth by adjusting both Optional Gauge Wheels the same direction from the bottom of the tire to the tip of the Shank, which is the approximate working depth of the Shank. Loosen the 5/8-11 x 3 Bolts without removing the Nuts and raise or lower the Gauge Wheels to the desired depth. Tighten all hardware to the recommended torques and check periodically for looseness. **See "General Torque Specifications" on page 4-1.**
3. Always lift the Chisel Plow completely out of the ground before turning or backing to prevent shank damage or damage to their respective mounting brackets.
4. Reduce speed at field ends, raise the Chisel Plow out of the ground.
5. After a few hours of initial operation, check all hardware for tightness. Tighten any loose Hardware.

Spring Shank Tension Adjustment

For normal operation, the Locknuts on the Spring mounting should be tightened so that one inch of thread is exposed. **See Figure 3-1.**

In tougher soil you may want to increase the Spring tension or compress the spring more. Keep in mind that when this is done, the shank and tooth will not pass over as great of obstruction.

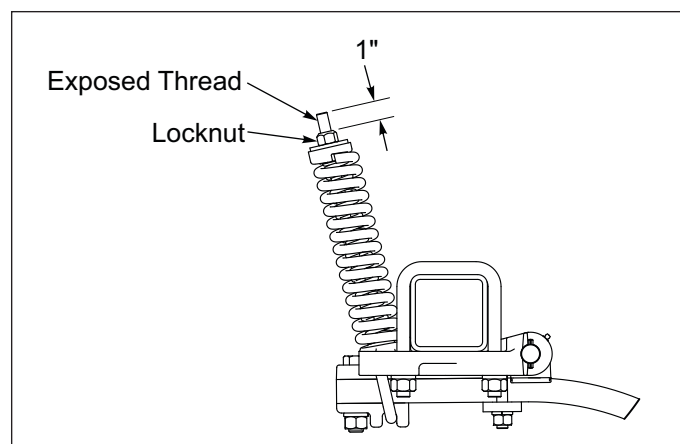

Figure 3-1: Spring Tension

Transport

1. Check and follow all federal, state, and local requirements before transporting the Chisel Plow.
2. The Chisel Plow should be transported only by tractor required for field operation. The machine weight should not exceed more than 1.5 times the tractor weight. Maximum transport speed for the Chisel Plow is 20 mph.



CAUTION

Excessive speed may result in loss of control of the tractor and machine, reduced braking ability, or failure of the implement tire or structure. Do not exceed the implement maximum specified ground speed regardless of the capability of the maximum tractor speed.

3. When towing equipment in combination, the maximum equipment ground speed shall be limited to the lowest specified ground speed of any of the towed machines.
Maximum transport speed shall be the lesser of travel speed specified in the operator's manual, speed identification symbol, information sign of towed equipment, or limit of road conditions.
4. Slow down when driving on rough roads. Reduce speed when turning, or on curves and slopes to avoid tipping. Equipment altered other than the place of manufacture may reduce the maximum transport speed. Additional weight, added tanks, harrowing attachments, etc. may reduce machine load carrying capabilities.

5. Before transporting:
 - Know the transport heights and widths of the unit before transporting. Use caution when transporting near bridges and power lines.



DANGER

Stay away from power lines when transporting, extending machine. Electrocuting can occur without direct contact.

- Raise the machine to full transport height.
- Check that tires are of proper size, load rating, and inflated to manufacture specifications before transporting. Check wheel lug bolts to ensure tightness. **See "Tires" on page 4-2.**
- Verify that all warning lights, SMV sign, reflectors, and safety decals are clearly visible and functioning properly.
- Transport during daylight hours when ever possible. Always use flashing warning lights, except where such use is prohibited by law. Make sure lights, reflectors and SMV emblem are clearly visible and operating. Remove any obstructions such as dirt, mud, stalks or residue that restricts view before transporting. **See Figure 3-2.**

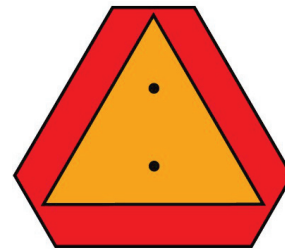

Figure 3-2: SMV Sign

Maintenance

General Torque Specifications

(rev. 4/97)

This chart provides tightening torques for general purpose applications when special torques are not specified on process or drawing. Assembly torques apply to plated nuts and capscrews assembled without supplemental lubrication (as received condition). They do not apply if special graphite moly-disulfide or other extreme pressure lubricants are used. When fasteners are dry (solvent cleaned) add 33% to as received condition torque. Bolt head identification marks indicate grade and may vary from manufacturer to manufacturer. Thick nuts must be used on grade 8 capscrews. Use value in [] if using prevailing torque nuts.

TORQUE SPECIFIED IN FOOT POUNDS

UNF SIZE	SAE Grade 2	SAE Grade 5	SAE Grade 8	UNF SIZE	SAE Grade 2	SAE Grade 5	SAE Grade 8
1/4-20	4 [5]	6 [7]	9 [11]	1/4-28	5 [6]	7 [9]	10 [12]
5/16-18	8 [10]	13 [13]	18 [22]	5/16-24	9 [11]	14 [17]	20 [25]
3/8-16	15 [19]	23 [29]	35 [42]	3/8-24	17 [21]	25 [31]	35 [44]
7/16-14	24 [30]	35 [43]	55 [62]	7/16-20	27 [34]	40 [50]	60 [75]
1/2-13	35 [43]	55 [62]	80 [100]	1/2-20	40 [50]	65 [81]	90 [112]
9/16-12	55 [62]	80 [100]	110 [137]	9/16-18	60 [75]	90 [112]	130 [162]
5/8-11	75 [94]	110 [137]	170 [212]	5/8-18	85 [106]	130 [162]	180 [225]
3/4-10	130 [162]	200 [250]	280 [350]	3/4-16	150 [188]	220 [275]	320 [400]
7/8-9	125 [156]	320 [400]	460 [575]	7/8-14	140 [175]	360 [450]	500 [625]
1-8	190 [237]	408 [506]	680 [850]	1-14	210 [263]	540 [675]	760 [950]
1-1/8-7	270 [337]	600 [750]	960 [1200]	1-1/8-12	300 [375]	660 [825]	1080 [1350]
1-1/4-7	380 [475]	840 [1050]	1426 [1782]	1-1/4-12	420 [525]	920 [1150]	1500 [1875]
1-3/8-6	490 [612]	1010 [1375]	1780 [2225]	1-3/8-12	560 [700]	1260 [1575]	2010 [2512]
1-1/2-6	650 [812]	1460 [1825]	2360 [2950]	1-1/2-12	730 [912]	1640 [2050]	2660 [3325]

METRIC:

Coarse thread metric class 10.9 fasteners and class 10.0 nuts and through hardened flat washers, phosphate coated, Rockwell "C" 38-45. Use value in [] if using prevailing torque nuts.

Nominal thread diameter (mm)	Newton Meters (Standard Torque)	Foot Pounds (Standard Torque)	Nominal Thread Diameter (mm)	Newton Meters (Standard Torque)	Foot Pounds (Standard Torque)
6	10 [14]	7 [10]	20	385 [450]	290 [335]
7	16 [22]	12 [16]	24	670 [775]	500 [625]
8	23 [32]	17 [24]	27	980 [1105]	730 [825]
10	46 [60]	34 [47]	30	1330 [1470]	990 [1090]
12	80 [125]	60 [75]	33	1790 [1950]	1340 [1450]
14	125 [155]	90 [115]	36	2325 [2515]	1730 [1870]
16	200 [240]	150 [180]	39	3010 [3210]	2240 [2380]
18	275 [330]	205 [245]			

MAINTENANCE

Fasteners

Before operating your Brillion machine, check all hardware for tightness. Use the Tightening Torque Table as a guide. **See Figure 4-1.**

After a few hours of use, check entire machine and tighten any loose nuts or bolts. Daily or periodic checks should be made thereafter.

When replacing bolts, be sure to use fasteners of equal grade.

Tires

Recommended tire sizes are 7.6 x 15-6 Ply Tire and should be inflated to 40 PSI.

When Re-Installing the Wheel Nuts tighten to 50 foot-pounds using the sequence in **Figure 4-1.** Then tighten to full torque of 85-100 Ft-lbs.

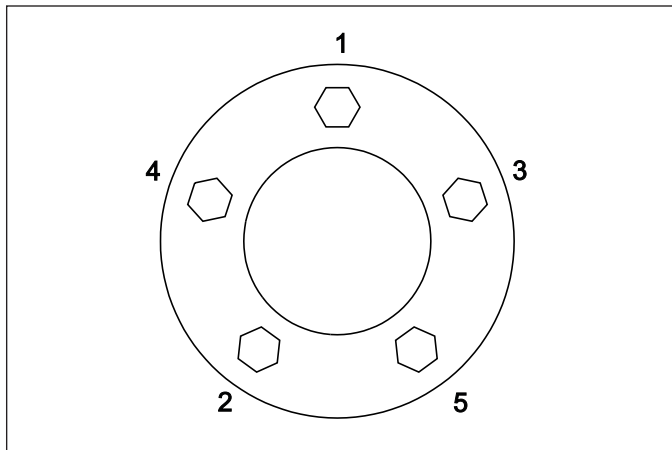

Figure 4-1: Stud Tightening Sequence

Points

NOTE

When replacing or reversing point, change all points at the same time so that they will have the same operating depth. If some shanks have worn points, or points of a different design, the Chisel Plow will not operate efficiently.

Lubrication Maintenance

- Wheel Hub Lubrication should be performed at the beginning of every season of use. Check the wheel bearings periodically for excessive end play.
- Grease Wheel Hubs every 50 hours. **See Figure 4-2.**
- Grease Spring Shank Clamp every 10 Hours to prevent seizure. **See Figure 4-3.**

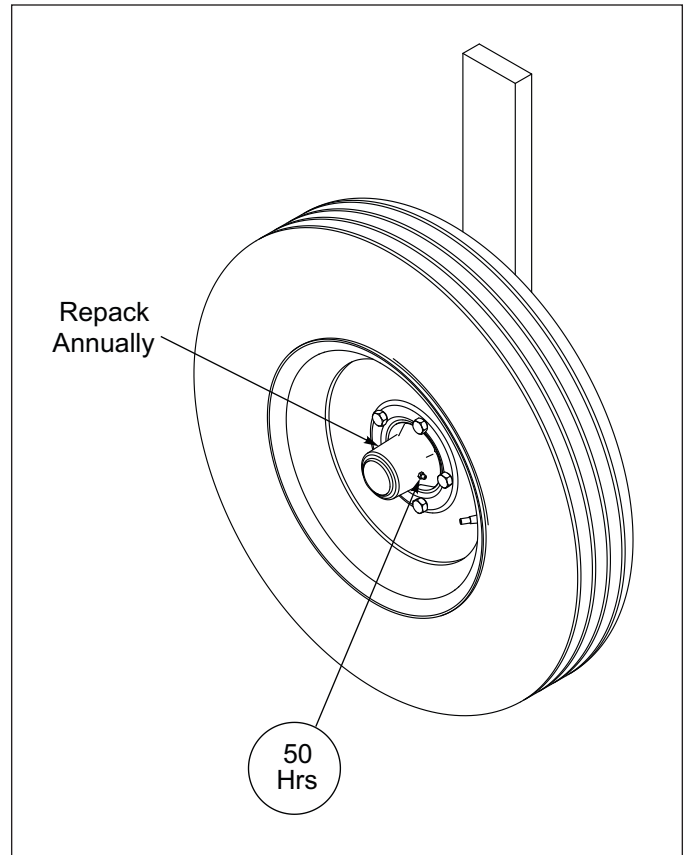

Figure 4-2: Wheel Hub Lubrication

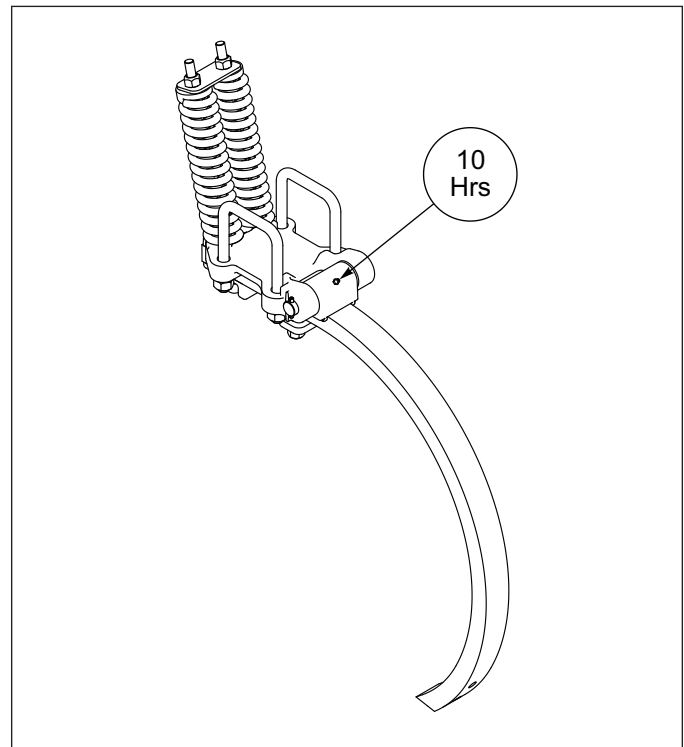

Figure 4-3: Spring Shank Lubrication

Storage

1. The service life of the Chisel Plow will be extended by proper off-season storage practices. Prior to storing the unit, complete the following procedures:
 - Completely clean the unit.
 - Inspect the machine for worn or defective parts. Replace as needed.
 - Repaint all areas where the original paint is worn off.
 - Grease all exposed metal surfaces of Shanks and Points.
2. Store the unit in a shed or under a tarpaulin to protect it from the weather. The ground tools and tires should rest on boards, or some other object, to keep them out of the soil.
3. Block wheels before unhitching from tractor.

Specifications

Product Attributes	CPPR2-5	CPPS21-5
Approximate Weight	455 lbs. (206 kg)	590 lbs. (268 kg)
Working Width	5 ft. 0 in. (1.5 m)	5 ft. 0 in. (1.5 m)
Transport Width	6 ft. 6 in. (2.0 m)	6 ft. 6 in. (2.0 m)
Transport Height	4 ft. 0 in. (1.2 m)	4 ft. 0 in. (1.2 m)
Overall Length	5 ft. 3 in. (1.6 m)	5 ft. 3 in. (1.6 m)
Number of Shanks	5	5
Shank Mount	Rigid	Dual Nested Spring
Shank Size	1 in. x 2 in. x 26 in. (25.4 x 50.8 x 660 mm)	1 in. x 2 in. x 26 in. (25.4 x 50.8 x 660 mm)
Shank Spacing	12 in. (300 mm)	12 in. (300 mm)
Shank Working Depth	Maximum 12 in. (300 mm)	Maximum 12 in. (300 mm)
Spring Pressure / Trip Resistance	N/A - Rigid Shanks on this Model	550 lbs. to 825 lbs. (248 kg to 371 kg)
Shank Trip Height	N/A	5.5 in. (138 mm)
Chisel Points Available	2 in. (50.8 mm) Reversible Point or 3 in. (76.2 mm) Reversible Twisted Point	2 in. (50.8 mm) Reversible Point or 3 in. (76.2 mm) Reversible Twisted Point
Under Frame Clearance	27.5 in. (688 mm)	27.5 in. (688 mm)
Frame Structure	4 in. x 4 in. x .187 in. (100 x 100 x 4.67 mm)	4 in. x 4 in. x .187 in. (100 x 100 x 4.67 mm)
Three-Point Hitch	Cat. II Free Link; Cat. II, IIIN Quick Coupler Hitch	Cat. II Free Link; Cat. II, IIIN Quick Coupler Hitch
SMV Emblem	Standard	Standard
Powder Coat Paint, Red	Standard	Standard
Optional Equipment	Safety Warning Lights Manual Adjust Gauge Wheel Kit Shank and Clamp Assemblies	Safety Warning Lights Manual Adjust Gauge Wheel Kit Shank and Clamp Assemblies
Horsepower Requirements	10 to 15 HP (8 to 11 kW) per Shank	10 to 15 HP (8 to 11 kW) per Shank
Recommended Operating Speed	4 to 6 MPH (6.43 to 9.65 km/h)	4 to 6 MPH (6.43 to 9.65 km/h)

Specifications subject to change with or without notice.

Figure 5-1: Model Specifications (1 of 2)

Product Attributes	CPPR2-7	CPPS21-7
Approximate Weight	533 lbs. (242 kg)	722 lbs. (328 kg)
Working Width	7 ft. 0 in. (2.1 m)	7 ft. 0 in. (2.1 m)
Transport Width	8 ft. 6 in. (2.6 m)	8 ft. 6 in. (2.6 m)
Transport Height	4 ft. 0 in. (1.2 m)	4 ft. 0 in. (1.2 m)
Overall Length	5 ft. 3 in. (1.6 m)	5 ft. 3 in. (1.6 m)
Number of Shanks	7	7
Shank Mount	Rigid	Dual Nested Spring
Shank Size	1 in. x 2 in. x 26 in. (25.4 x 50.8 x 660 mm)	1 in. x 2 in. x 26 in. (25.4 x 50.8 x 660 mm)
Shank Spacing	12 in. (300 mm)	12 in. (300 mm)
Shank Working Depth	Maximum 12 in. (300 mm)	Maximum 12 in. (300 mm)
Spring Pressure / Trip Resistance	N/A - Rigid Shanks on this Model	550 lbs. to 825 lbs. (248 kg to 371 kg)
Shank Trip Height	N/A	5.5 in. (138 mm)
Chisel Points Available	2 in. (50.8 mm) Reversible Point or 3 in. (76.2 mm) Reversible Twisted Point	2 in. (50.8 mm) Reversible Point or 3 in. (76.2 mm) Reversible Twisted Point
Under Frame Clearance	27.5 in. (688 mm)	27.5 in. (688 mm)
Frame Structure	4 in. x 4 in. x .187 in. (100 x 100 x 4.67 mm)	4 in. x 4 in. x .187 in. (100 x 100 x 4.67 mm)
Three-Point Hitch	Cat. II Free Link; Cat. II, IIIN Quick Coupler Hitch	Cat. II Free Link; Cat. II, IIIN Quick Coupler Hitch
SMV Emblem	Standard	Standard
Powder Coat Paint, Red	Standard	Standard
Optional Equipment	Safety Warning Lights Manual Adjust Gauge Wheel Kit Shank and Clamp Assemblies	Safety Warning Lights Manual Adjust Gauge Wheel Kit Shank and Clamp Assemblies
Horsepower Requirements	10 to 15 HP (8 to 11 kW) per Shank	10 to 15 HP (8 to 11 kW) per Shank
Recommended Operating Speed	4 to 6 MPH (6.43 to 9.65 km/h)	4 to 6 MPH (6.43 to 9.65 km/h)

Specifications subject to change with or without notice.

Figure 5-2: Model Specification (2 of 2)

Illustrated Parts List

Frame

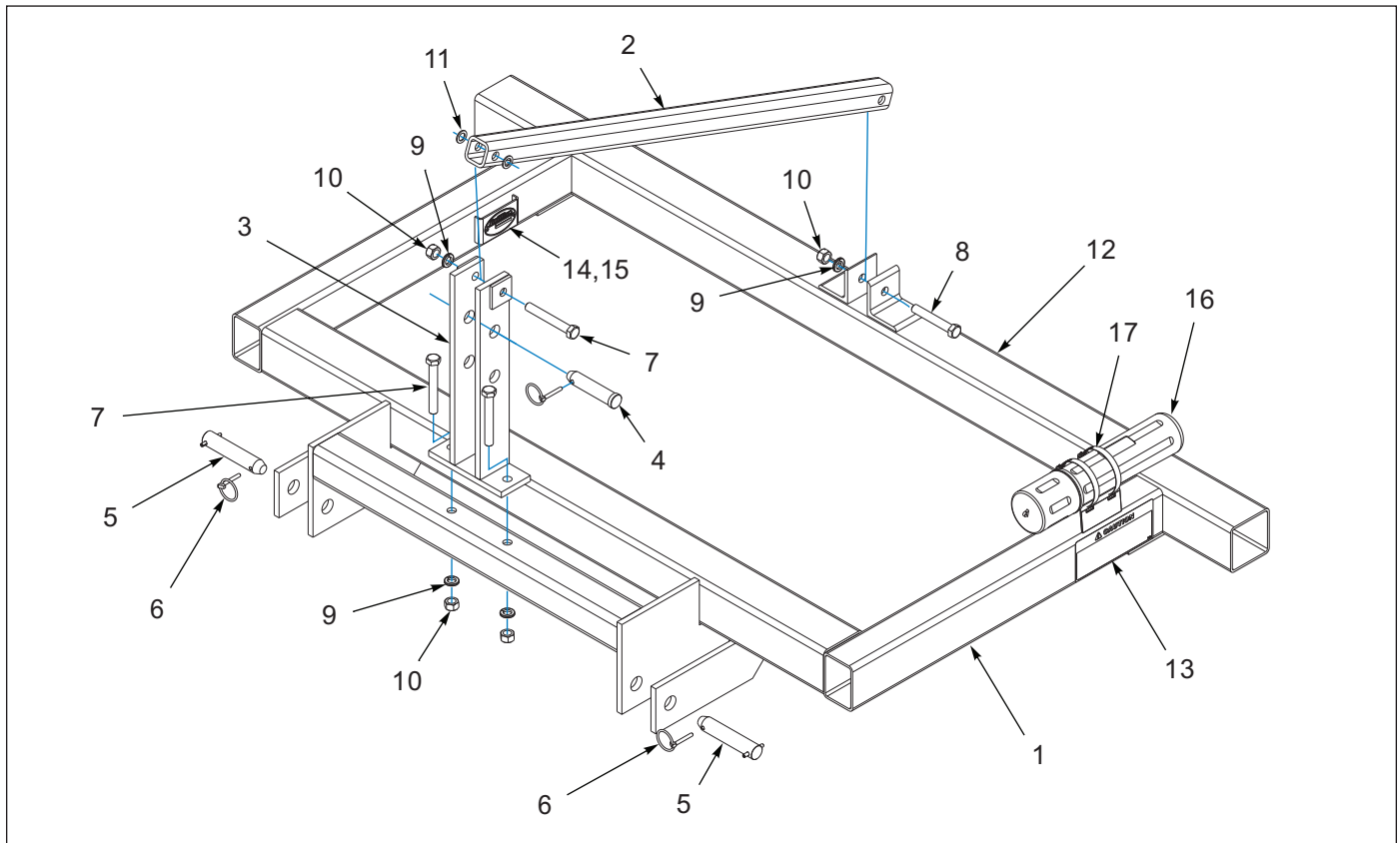

Figure 6-1: Frame

Frame

ITEM	PART NUMBER	DESCRIPTION	QTY
1	9D976	FRAME ASSEMBLY-CHISEL	1
2	9D979	BRACE TUBE	1
3	9D978	MAST	1
4	6D529	CLEVIS PIN 1.0 X 4.5	1
5	5D156	PIN ASSEMBLY 1-1/8X5-3/4	2
6	1-557-010327	KLIK PIN 1/4 X 1-1/4	3
7	1-654-010059-14	SCREW HX CP 5/8-11X4-1/2 GR5	2
8	1-654-010059-13	SCREW HEX CAP 5/8-11X4UNC GR5	2
9	1-861-010034-15	WASHER,LKG,HLCL SPR,5/8	4
10	1-512-010007-11	NUT, HEX 5/8-11 GR2 ZP	4
11	8C892	MACHINERY BUSHING 1" ODX5/8"ID	2
12	4K036	DECAL-BRILLION (2 3/4 X 20)	2
13	8J310	DECAL - CAUTION	1
14	1-573-010006	PLACARD, NAME	1
15	107-0814	RIVET 1/8X1/8 A LUM POP (HARDWARE FOR ITEM 14)	2
16	1-116-010019	MANUAL STORAGE CANISTER	1
17	105-0093	HOSE CLAMP 4-1/2 IDEAL #5264	2

Rigid Shank Assembly

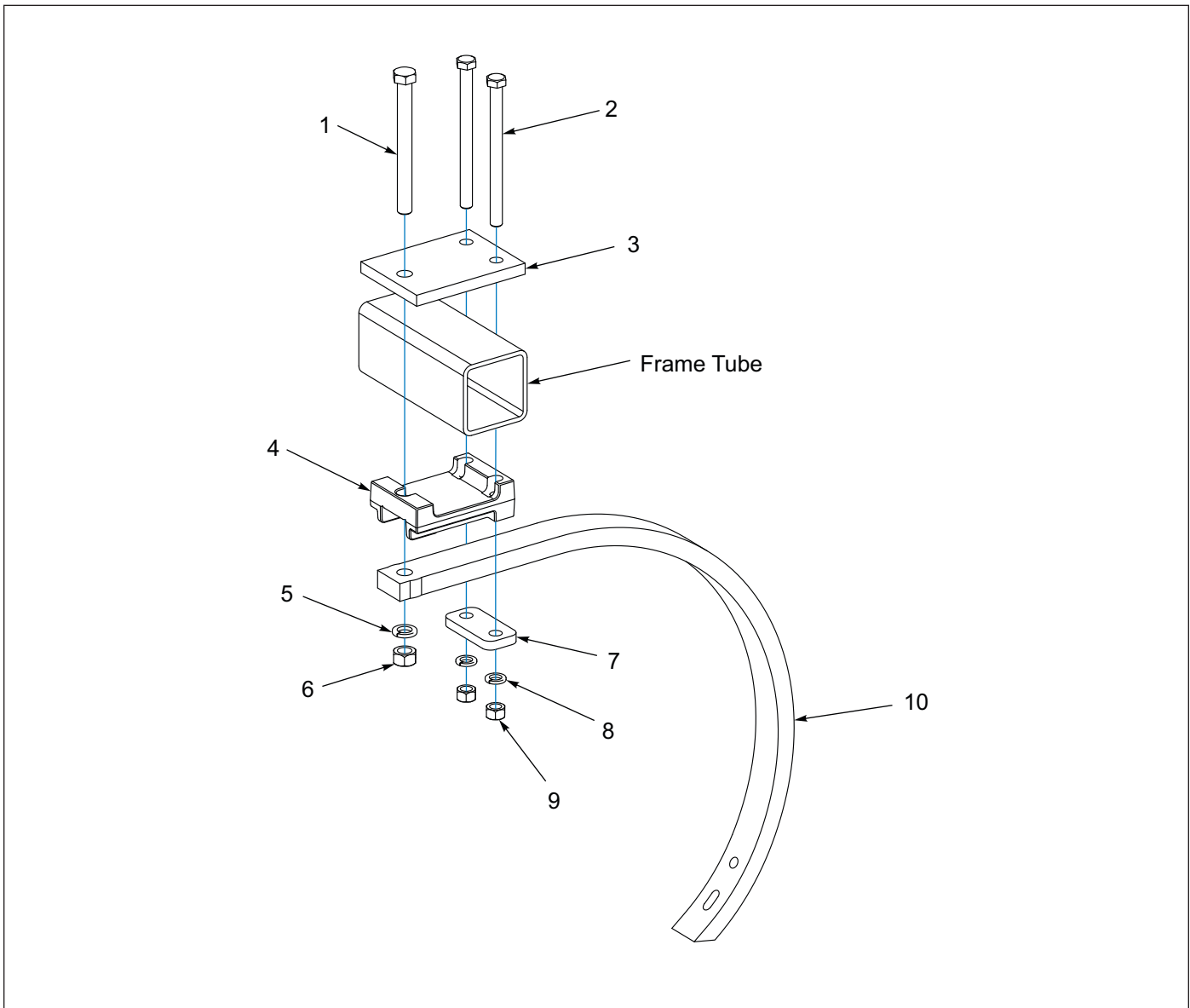

Figure 6-2: Rigid Shank Assembly

Rigid Shank Assembly

ITEM	PART NUMBER	DESCRIPTION	QTY
	6D161	SHANK BUNDLE 26-R	1
1	1-654-010061-20	SCREW, HX CP 3/4-10UNC X 7-1/2, G5	1
2	1-654-010059-21	SCREW, HEX CAP 5/8-11UNC X 8, GR5	2
3	6D298	PLATE	1
4	6D234	SHANK SUPPORT (7002538)	1
5	1-861-010034-17	WASHER, LKG HLCL SPR, 3/4	1
6	1-512-010007-12	NUT, HEX 3/4-10	1
7	6D280	STRAP	1
8	1-861-010034-15	WASHER, LKG,HLCL SPR, 5/8	2
9	1-512-010007-11	NUT, HEX 5/8-11 GR2 ZP	2
10	6D283	SHANK - 26S	1

Shank and Spring Clamp Assembly

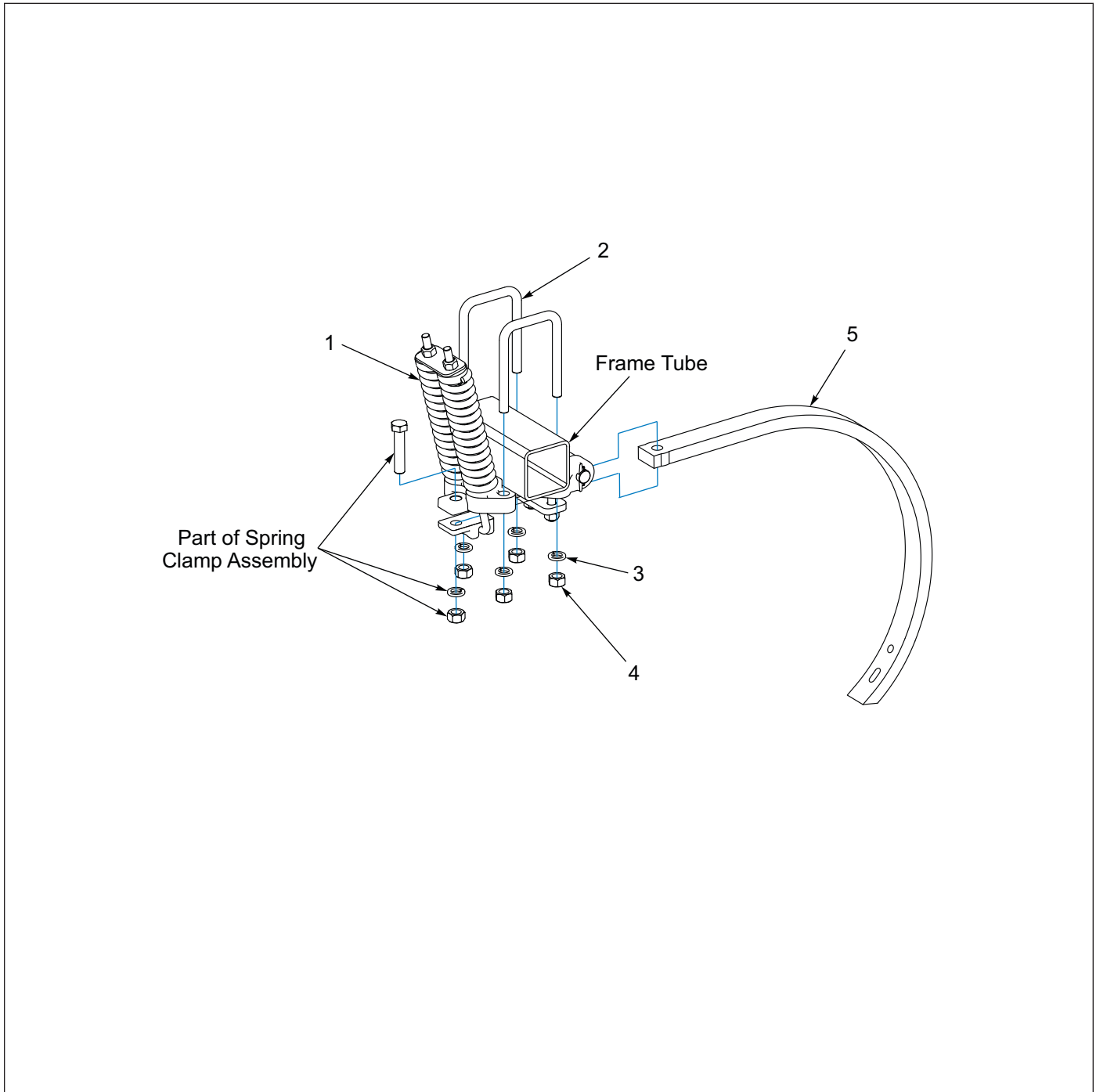

Figure 6-3: Shank and Spring Clamp Assembly

Shank and Spring Clamp Assembly

ITEM	PART NUMBER	DESCRIPTION	QTY
1	4J681	SPRING CLAMP ASM (SEE PAGE 6-4)	1
2	4J293	U-BOLT, 3/4-10 X 6-3/8 X 4-3/4	2
3	1-861-010034-17	WASHER, LKG, HLCL, SPR, 3/4	4
4	1-512-010007-12	NUT, HEX 3/4-10 GR2, ZP	4
5	6D283	SHANK - 26S	1

Spring Shank Assembly

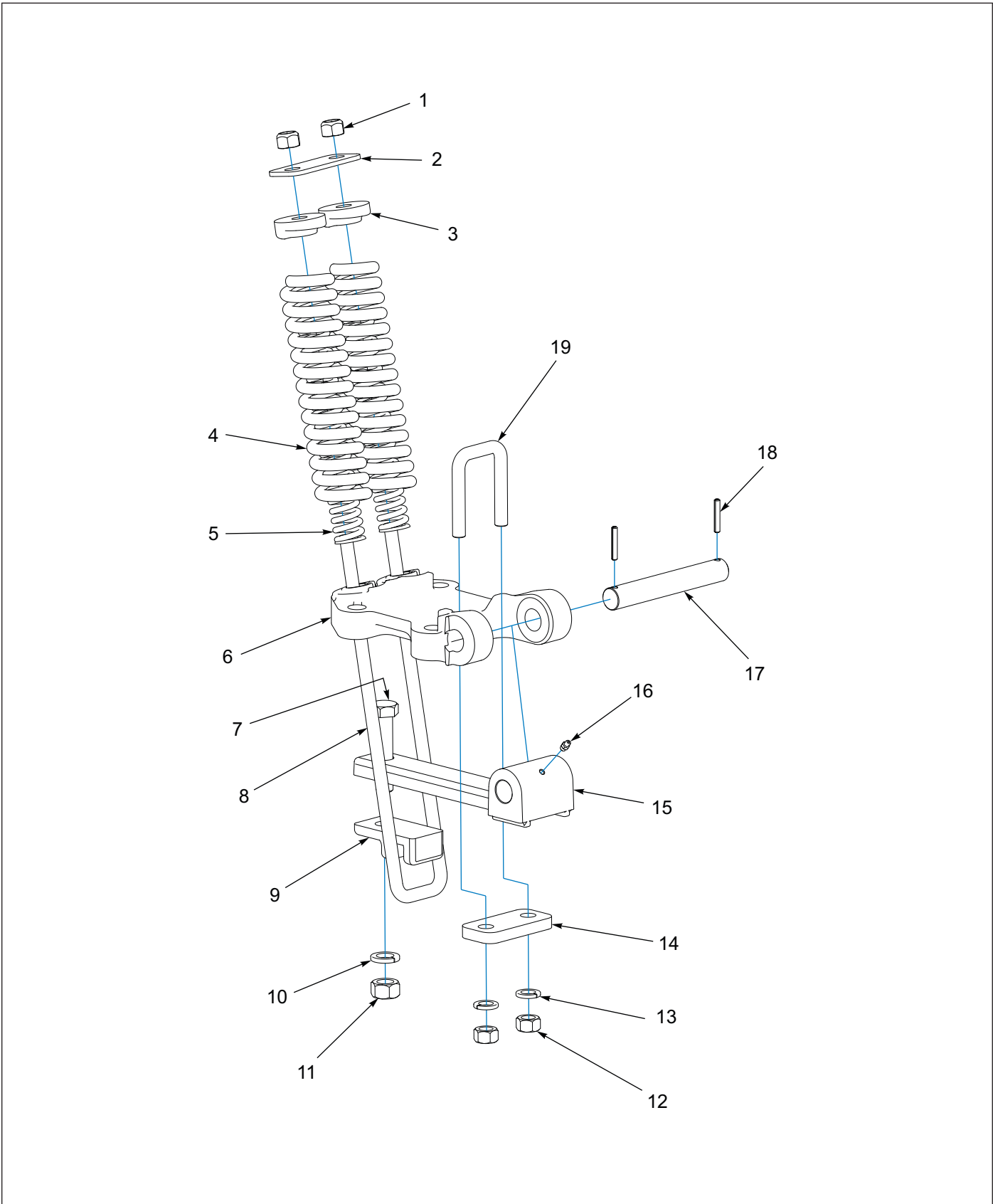

Figure 6-4: Spring Shank Assembly

Spring Shank Assembly

ITEM	PART NUMBER	DESCRIPTION	QTY
	4J681	SPRING CLAMP ASM	1
1	1-512-010005-13	NUT, HEX, SLFLKG GRB 5/8-11	2
2	6D409	STRAP	1
3	6J459	CAP	2
4	4K076	COMPRESSION SPRING - OUTER	2
5	6D362	COMPRESSION SPRING - INNER	2
6	4J675	SHANK CLAMP (7003861)	1
7	141776	SCREWHXCP 3/4-10UNCX3-1/2GR5B	1
8	8J163	U-BOLT 5/8-11 X 16 X 2-3/4 ZP	1
9	2J091	U-BOLT CLIP 7002209 W/7003861	1
10	1-861-010034-17	WASHER, LKG, HLCL SPR, 3/4	1
11	1-512-010007-12	NUT, HEX 3/4-10 GR2, ZP	1
12	1-512-010007-11	NUT, HEX 5/8-11 GR2, ZP	2
13	1-861-010034-15	WASHER, LKG HLCL SPR, 5/8	2
14	6D280	STRAP	1
15	2J092	SHANK HOLDER (7002212)	1
16	1-298-010001-1	ZERK FITTING 1/4 SAE	1
17	8J130	PIN, 1.0 X 6.875 PLATED	1
18	1-647-010004217	SPRING PIN, SLOTTED 1/4X1-1/2	2
19	2J094	U-BOLT 5/8-11 X 3-3/8 X 2-5/8	1

Points

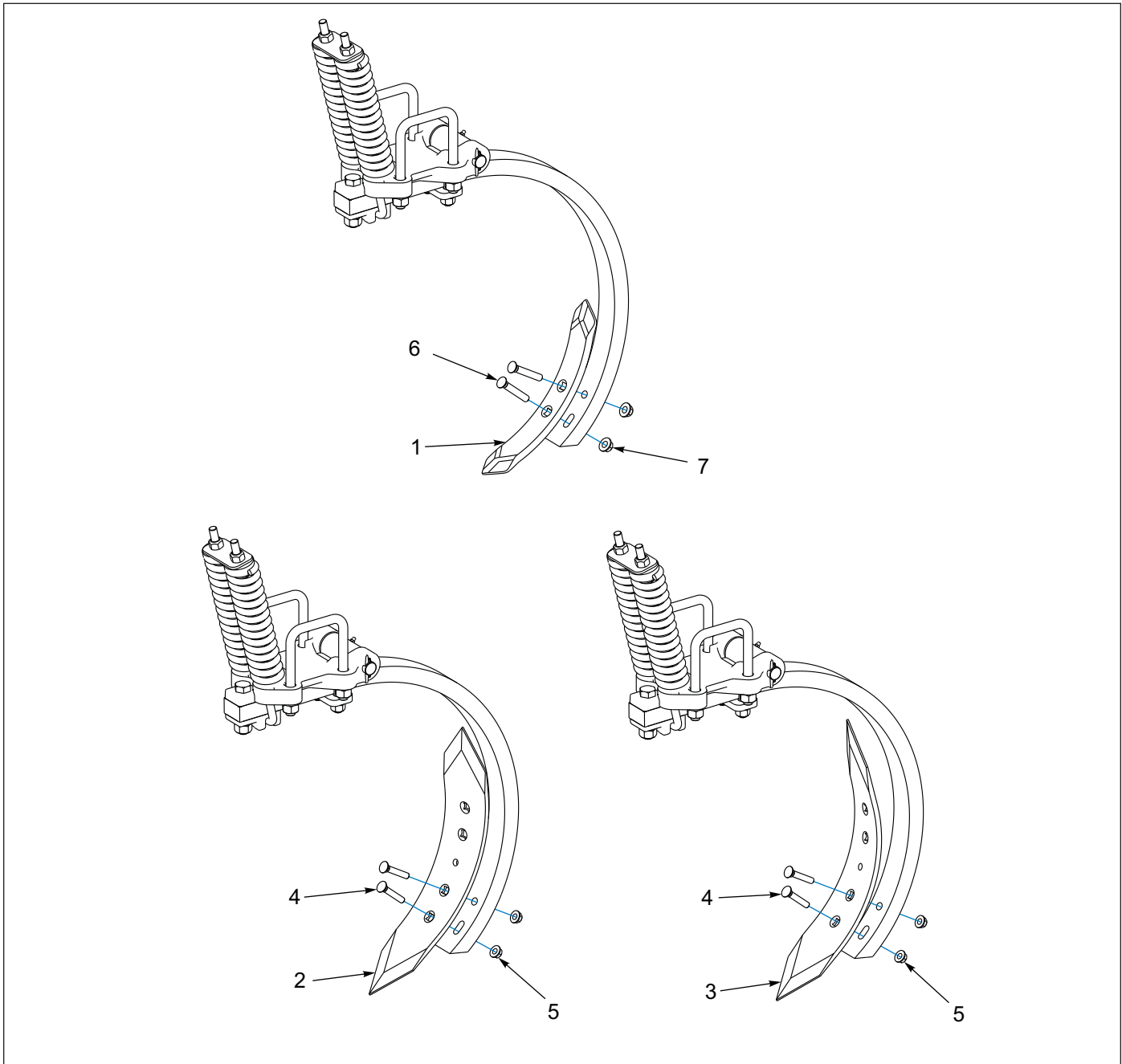

Figure 6-5: Points

Points

ITEM	PART NUMBER	DESCRIPTION	QTY
1	6D213	CHISEL POINT	1
2	6D216	REV. DBL.PT. TW SHOVEL (LEFT)	1
3	6D215	REV. DBL.PT. TW SHOVEL (RIGHT)	1
4	7K964	SPECIAL PLOW BOLT	2
5	4K551	SELF-LOCKING FLANGE NUT (7/16-14)	2
6	1/2-13X3PLOW	PLOW BOLT GR5	2
7	4K552	SELF-LOCKING FLANGENUT (1/2-13)	2

SMV Assembly

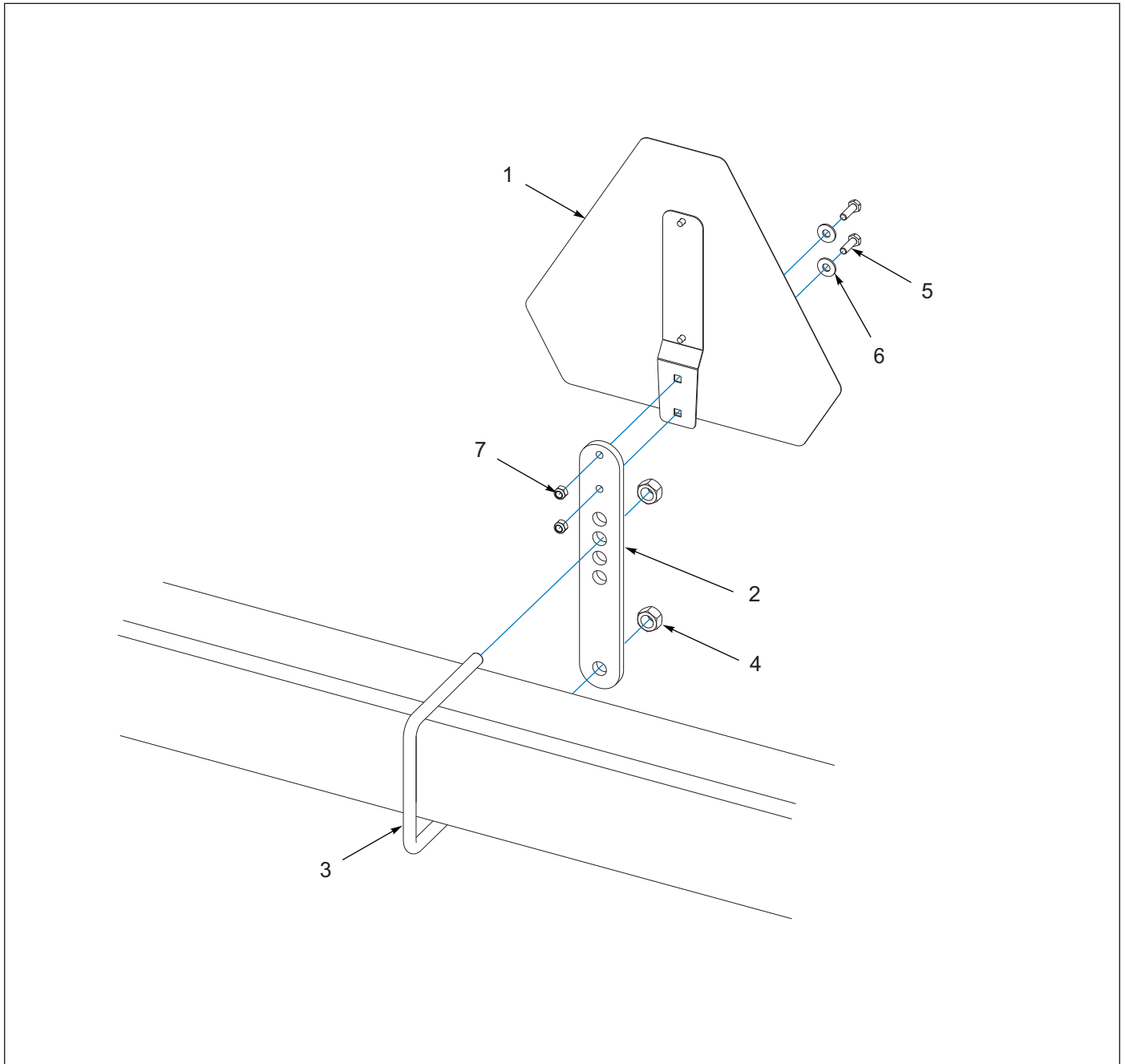

Figure 6-6: SMV Assembly

SMV Assembly

ITEM	PART NUMBER	DESCRIPTION	QTY
1	2P151	SMV W/BRACKET	1
2	164678	MOUNT, SMV	1
3	9D989	U-BOLT 5/8-11X5-5/8X4-11/16	1
4	1-512-010005-13	NUT,HEX SLFLKG GRB 5/8-11	1
5	1-654-010049-05	SCREW HX CP 5/16-18UNCX1 GR5	2
6	1-861-010032-09	WASHER, FLAT 5/16 W ZP/CD	2
7	104032	NUT,HX SLF-LKG W/MYL 5/16-18	2

Gauge Wheel Kit (Optional)

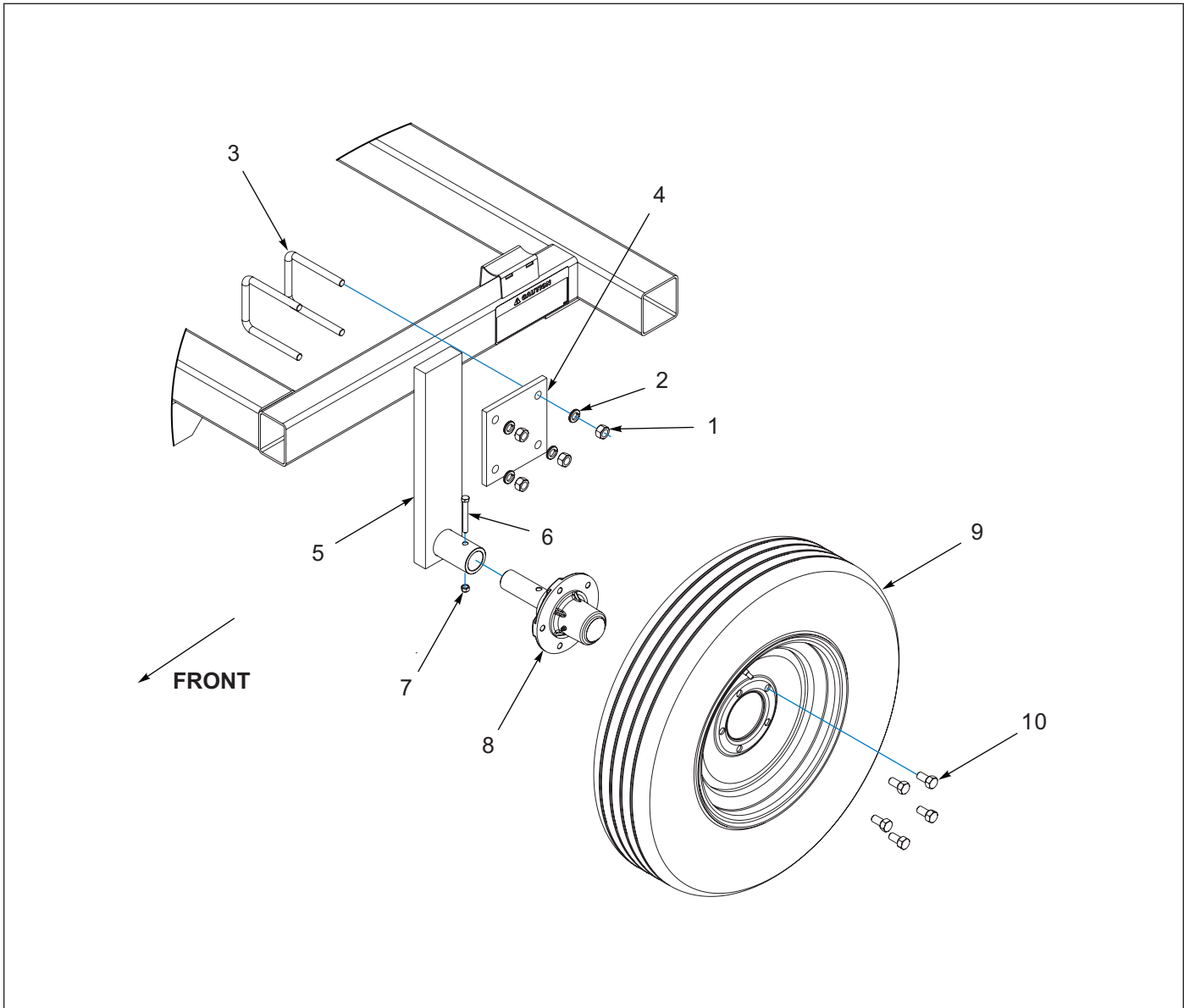

Figure 6-7: Gauge Wheel Kit (Optional)

Gauge Wheel Kit (Optional)

ITEM	PART NUMBER	DESCRIPTION	QTY
	9D986	CCP2 GAUGE WHEEL KIT	1
1	1-512-010007-11	NUT, HEX 5/8-11 ZP GR2	12
2	1-861-010034-15	WASHER 5/8 SLW	12
3	9D989	U-BOLT 5/8-11X5-5/8X4-11/16	4
4	9D988	PLATE	2
5	168345	ARM WELDMENT	2
6	1-654-010051-13	SCREW, HX CP, 3/8-16UNCX3, GR5	2
7	1-512-010005-05	NUT, HEX, SLFLKG GRB 3/8-16	2
8	1J398	HUB & SPINDLE ASSEMBLY (SEE PAGE 6-9)	2
9	6K911	WHEEL 8J789/NO TUBE/4C129 (SEE PAGE 6-10)	2
10	5C100	WHEEL BOLT 1/2-20X1 GR5 ZP	10

Hub and Spindle Assembly

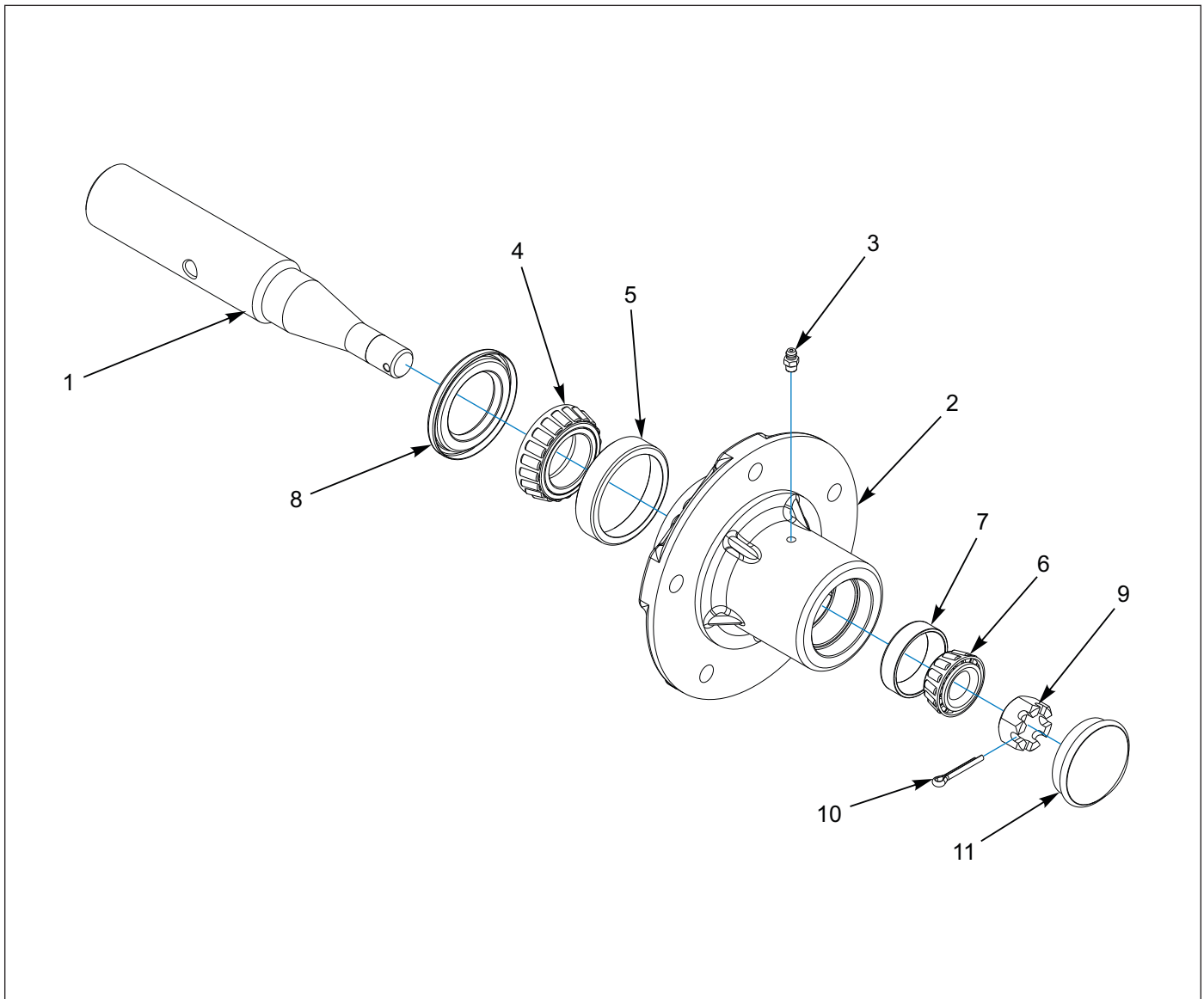

Figure 6-8: Hub and Spindle Assembly

Hub and Spindle Assembly

ITEM	PART NUMBER	DESCRIPTION	QTY
	1J398	HUB & SPINDLE ASSEMBLY	1
1	1J377	SPINDLE	1
2	1J390	WHEEL HUB - 5 BOLT (7001586) (INCLUDES ITEM 3)	1
3	1-298-010001-1	ZERK FITTING 1/4 SAE	1
4	712099	BEARING, CONE, 1.375X2.563X.71 (TIMKEN LM48548)	1
5	2107649	BEARING, CUP, 1.375X2.563X.71 (TIMKEN LM48510)	1
6	1-076-010008	OUTER CONE 4-BOLT HUB (TIMKEN LM11949)	1
7	5C912	CUP, BEARING (TIMKEN LM11910)	1
8	1D273	SEAL (SINGLE LIP)	1
9	3/4-16HSN	NUT, HX SLOT 3/4-16 HSN	1
10	110-0344	5/32X1 COTTER PIN	1
11	1J463	HUB CAP	1

Wheel Assembly

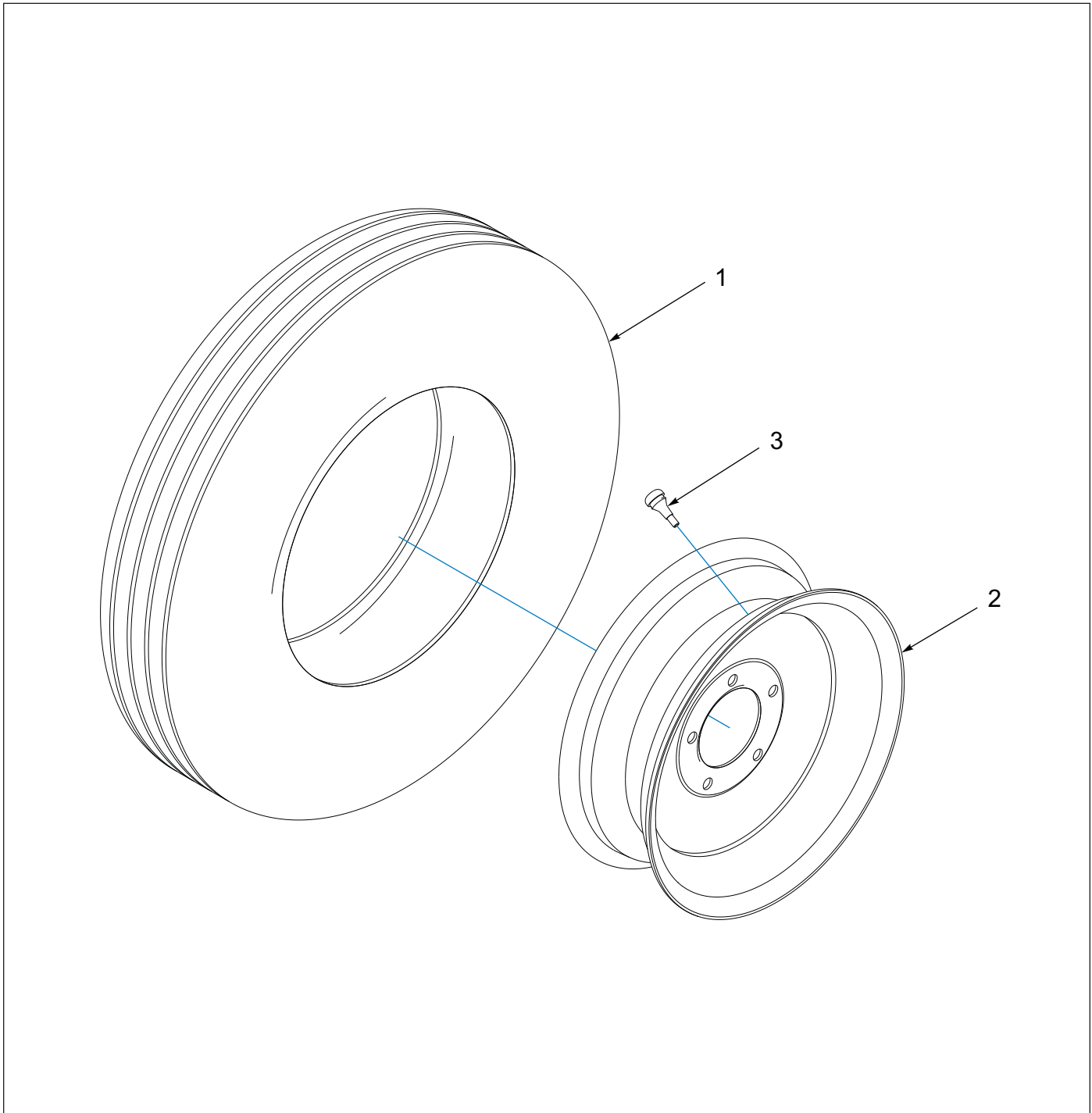

Figure 6-9: Wheel Assembly

Wheel Assembly

ITEM	PART NUMBER	DESCRIPTION	QTY
	6K911	WHEEL 8J789/NO TUBE/4C129	1
1	8J789	TIRE - 7.60 X 15 - 6 PLY	1
2	4C129	WHEEL - 15 X 5KB - 5 BOLT	1
3	8J792	VALVE STEM-TUBELESS	1

Decals

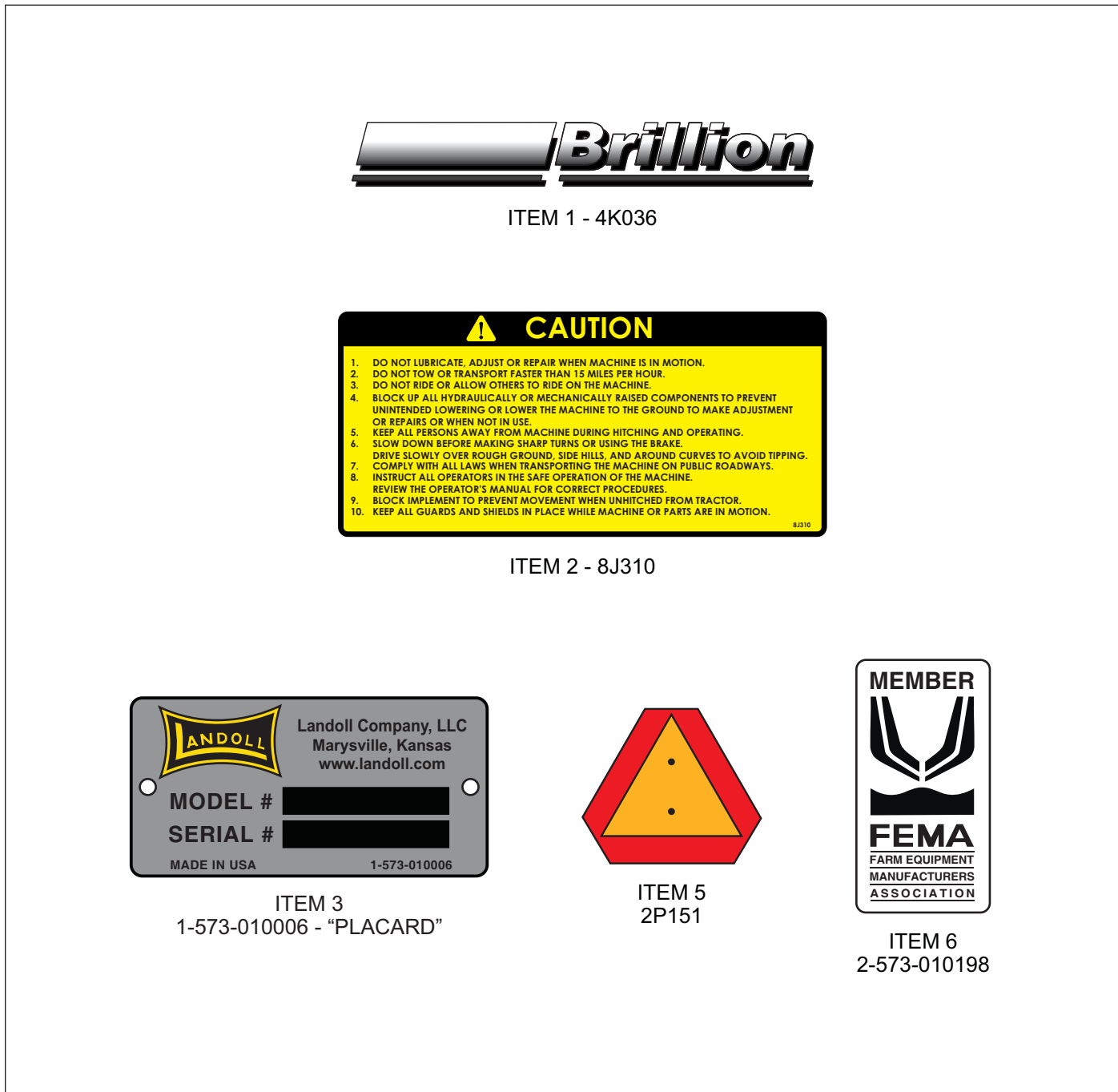

Figure 6-10: Decals

Decals

ITEM	PART NUMBER	DESCRIPTION	QTY
1	4K036	DECAL-BRILLION (2 3/4 X 20)	1
2	8J310	DECAL - CAUTION	1
3	1-573-010006	PLACARD, NAME	1
4	107-0814	RIVET 1/8X1/8 A LUM POP (HARDWARE FOR ITEM 3)	2
5	2P151	SMV W/BACKET	1
6	2-573-010198	DECAL, MEMBER FEMA	1

Decal Locations

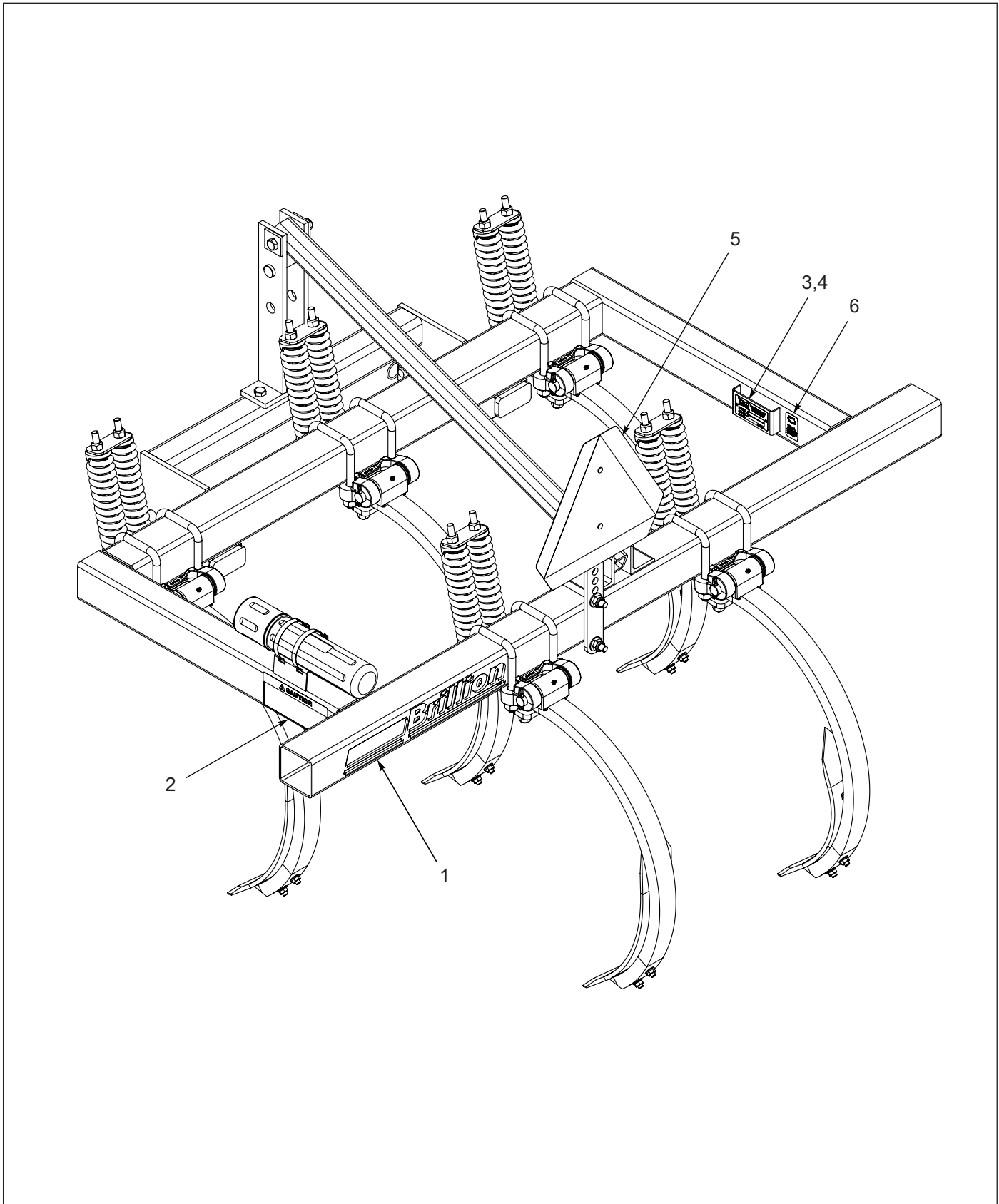

Figure 6-11: Decal Locations

Glossary

For clarity this glossary of industry standard abbreviations and their definitions are provided. For additional information, see instruction on the inside front cover or the last page of this manual.

A

ASM Assembly

B

BATT Battery
BHSC Button Head Socket Cap
BLK Black

C

CB Carriage Bolt
CONN Connector
CRG Carriage
CTSK Countersunk
CTWT Counterweight
CVR Cover
CYD Cylinder

D

DBL Double
DIA Diameter

E

ENCLSD Enclosed

F

FHCS Flanged Head Cap Screw
FHHCS Flanged Hex Head Cap Screw
FL OR FLG Flange
FLT Flat

G

GA Gauge

H

HHCS Hex Head Cap Screw
HCS High Carbon Steel
HD Head
HLCL Helical
HCSKT Hex Socket
HSFC Hex Socket Flat Countersunk
HYD Hydraulic

I

ID Inside Diameter

L

LH Lefthand
LKG OR LOCK Locking
LWR Lower

M

MANF Manifold
MNT Mount

N

NRW Narrow
----- Not Serviced Separately

O

OD Outside Diameter
OHG Overhead Guard
ORFS OR ORS O-Ring Seal
ORP OR ORB O-Ring Boss

P

P-STEER Power Steering
PTFE Polytetrafluoroethylene (Teflon)

GLOSSARY

R

RH Righthand
RND Round

S

SER Series
SHCS Socket Head Cap Screw
SHLD Shield
SKT Socket
SLFLKG Selflocking
SOC Socket
SPDT Single Pole Double Throw
SPR Spring
SQ Square
SRTD Serrated
SSCR Setscrew
SST Stainless Steel
STD Standard

U

UPR Upper

W

WHL Wheel
WLD OR WLDMT Weldment

Numerics

1/2-13X3PLOW 6-6

104032 6-7

105-0093 6-1

107-0814 6-1, 6-11

1-076-010008 6-9

110-0344 6-9

1-116-010019 6-1

1-298-010001-1 6-5, 6-9

141776 6-5

1-512-010005-05 6-8

1-512-010005-13 6-5, 6-7

1-512-010007-11 6-1, 6-2, 6-5, 6-8

1-512-010007-12 6-2, 6-3, 6-5

1-557-010327 6-1

1-573-010006 6-1, 6-11

164678 6-7

1-647-010004217 6-5

1-654-010049-05 6-7

1-654-010051-13 6-8

1-654-010059-13 6-1

1-654-010059-14 6-1

1-654-010059-21 6-2

1-654-010061-20 6-2

168345 6-8

1-861-010032-09 6-7

1-861-010034-15 6-1, 6-2, 6-5, 6-8

1-861-010034-17 6-2, 6-3, 6-5

1D273 6-9

1J377 6-9

1J390 6-9

1J398 6-8, 6-9

1J463 6-9

2107649 6-9

2-573-010198 6-11

2J091 6-5

2J092 6-5

2J094 6-5

2P151 6-7, 6-11

3/4-16HSN 6-9

4C129 6-10

4J293 6-3

4J675 6-5

4J681 6-3, 6-5

4K036 6-1, 6-11

4K076 6-5

4K551 6-6

4K552 6-6

5C100 6-8

5C912 6-9

5D156 6-1

6D161 6-2

6D213 6-6

6D215 6-6

6D216 6-6

6D234 6-2

6D280 6-2, 6-5

6D283 6-2, 6-3

6D298 6-2

6D362 6-5

6D409 6-5

6D529 6-1

6J459 6-5

6K911 6-8, 6-10

712099 6-9

7J990 6-7

7K964 6-6

8C892 6-1

8J130 6-5

8J163 6-5
8J310 6-1, 6-11
8J789 6-10
8J792 6-10
9D976 6-1
9D978 6-1
9D979 6-1
9D986 6-8
9D988 6-8
9D989 6-8

Instructions for Ordering Parts

**** Repair parts must be ordered through an Authorized Dealer ****

DEALER INSTRUCTIONS FOR ORDERING PARTS FROM LANDOLL PARTS DISTRIBUTION CENTER

Phone #: 800-423-4320 or 785-562-5381

Fax #: 888-527-3909

Order online: dealer.landoll.com

IDENTIFICATION PLATE

The identification plate, which lists the model and serial number of the equipment. It is located on the rear right hand, inside frame of the Chisel Plow.

SERIAL NUMBER NOMENCLATURE

The serial number for the Chisel Plow is located on the identification plate. The following information will help decode the Landoll serial number.

CPD2400100 = xxmysssss

xx	= model series (i.e. "CP" for all Chisel Plows)
m	= month of manufacture (ex. "D" means April. The letter I is not used.)
yy	= year manufactured (ex. "24" means 2024)
sssss	= Sequential number used to track warranty and service information.

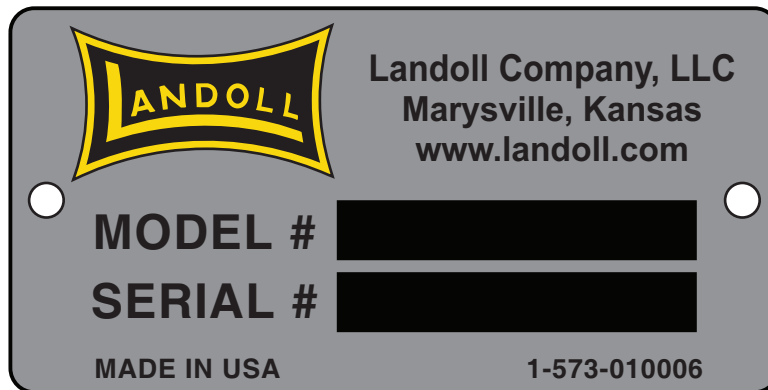

Identification Plate

Manuals for 2-Bar Pick-Up Chisel Plow

Manual Number	Manual Type
9D990	Operator's and Parts Manual

Document Control Revision Log:

Date	Form #	Improvement(s): Description and Comments
03/2006	9D990-0306	Initial Release (1273rev3-20-06)
01/2024	9D990-2401	Updated Manual / Revised Template *Revised Form Format "Year/Date" Updated ISO logos to ISO 9001:2015 (Revised 04/2024)



intertek

Equipment from Landoll Company, LLC is built to
exacting standards ensured by ISO 9001:2015 registration
at all Landoll manufacturing facilities.

**2-Bar Pick-Up Chisel Plow
Models: CPPR2-5, CPPR2-7,
CPPS2-5, CPPS2-7
Operation's and Parts Manual
Re-Order Part Number 9D990**

LANDOLL COMPANY, LLC

1900 North Street

Marysville, Kansas 66508

(785) 562-5381

800-428-5655 ~ WWW.LANDOLL.COM



Copyright 2024. Landoll Company, LLC

“All rights reserved, including the right to reproduce this material or portions thereof in any form.”

