

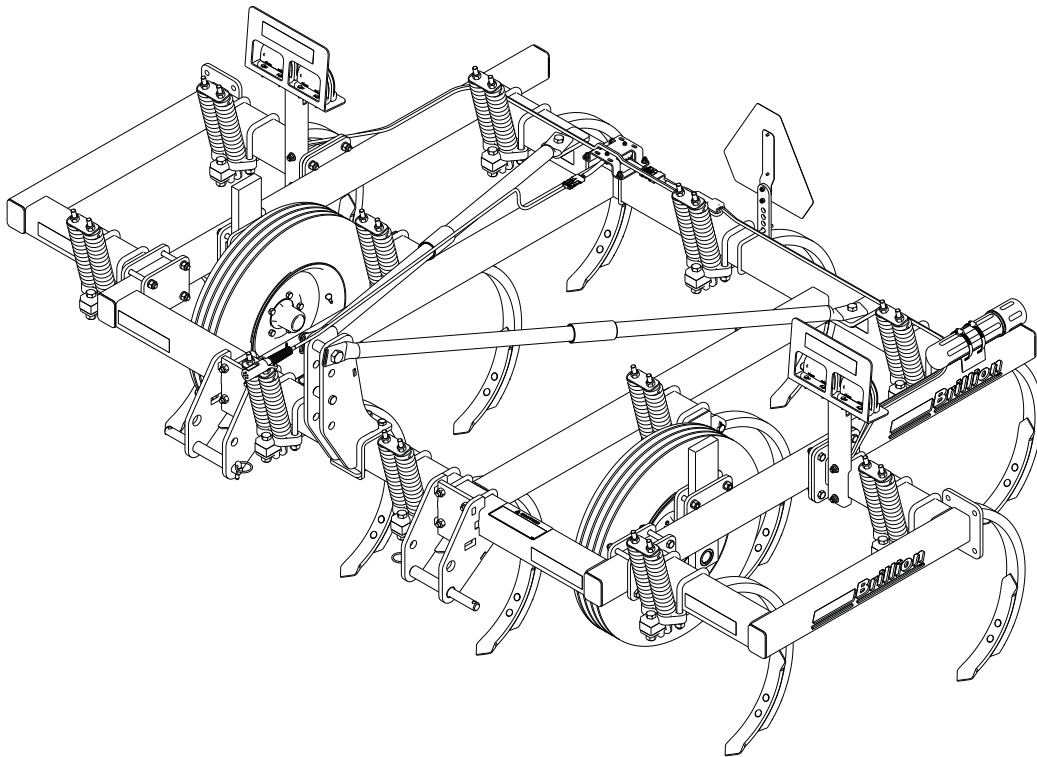

Chisel Plow

Models: CPP7 through CPP12

Parts Manual



LANDOLL COMPANY, LLC

1900 North Street
Marysville, Kansas 66508
(785) 562-5381

800-428-5655 ~ WWW.LANDOLL.COM

Table of Contents

1 Illustrated Parts List

Instructions for Ordering Parts	1-1
Frame 7 and 9 Shank Models	1-2
Frame 10 and 12 Shank Models	1-4
Frame 11 Shank Model	1-6
Shank and Spring Clamp Assembly	1-8
Spring Shank Assembly	1-10
Rigid Shank Assembly	1-12
Points	1-13
7 and 9 Foot Models LED Warning Lights	1-14
10 and 12 Foot Models LED Warning Lights	1-16
11 Foot Model LED Warning Lights	1-18
2 Foot Optional Extension Kit	1-20
4 Foot Optional Extension Kit	1-21
Optional Bracket Assemblies for Older Models (Prior to April 2016)	1-22
Optional Gauge Wheel Kit 32"	1-23
Optional Gauge Wheel Kit 26"	1-24
Hub and Bar Assembly	1-25
Hub and Bar Assembly	1-26
Hub and Spindle Assembly	1-27
Wheel	1-28
7 and 9 Foot Model Decals	1-30
10 and 12 Foot Model Decals	1-32
11 Foot Model Decals	1-34

2 Numerical Index

3 Glossary

Illustrated Parts List

Instructions for Ordering Parts

**** Repair parts must be ordered through an authorized dealer ****

DEALER INSTRUCTIONS FOR ORDERING PARTS FROM LANDOLL PARTS DISTRIBUTION CENTER

PHONE #: 800-423-4320 OR 785-562-5381

FAX #: 888-527-3909

ORDER ONLINE: Dealer.landoll.com

IDENTIFICATION PLATE

See Figure 1-1 for the Identification Plate, which lists the model and serial number of the equipment. It is located on the left side of the Chisel Plow.

SERIAL NUMBER NOMENCLATURE

The serial number for the Chisel Plow is located on the identification plate. The following information will help decode the Landoll serial number.

CPD2000100 = xxmyysss

xx	= model series (i.e. "CP" for all Chisel Plows)
m	= month of manufacture (ex. "D" means April. The letter I is not used.)
yy	= year manufactured (ex. "20" means 2020)
sss	= Sequential number used to track warranty and service information.



Figure 1-1: Identification Plate

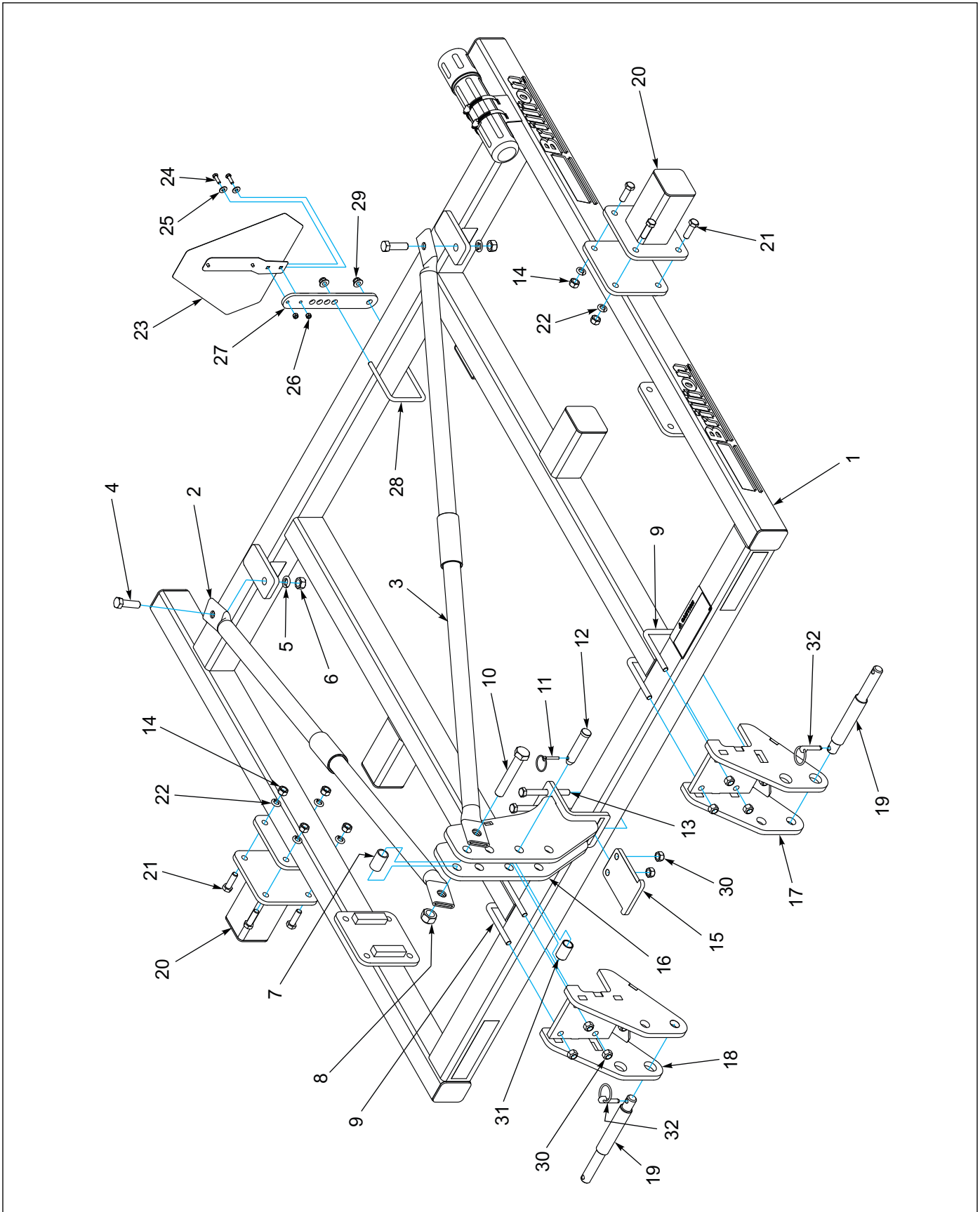

Figure 1-2: Frame 7 and 9 Shank Models

Frame 7 and 9 Shank Models

ITEM	PART NUMBER	DESCRIPTION	QTY
1	7D017	FRAME WELDMENT	1
2	7D472	R. H. BRACE	1
3	7D473	L. H. BRACE	1
4	1-654-010061-07	SCREW, HX CP 3/4-10UNC X 2-1/2, G5	2
5	1-861-010034-17	WASHER, LKG,HLCL SPR, 3/4	2
6	1-512-010007-12	NUT, HEX 3/4-10 GR2, ZP	2
7	6D988	SPACER	1
8	1-512-010005-19	NUT 1-8 HEX SLF-LOCKING GRB	1
9	9D989	U-BOLT, 5/8-11 X 5-5/8 X 4-11/16	4
10	1-654-10065-17	SCREW, HEX CAP, 1-8UNC X 6, GR5	1
11	1-557-010327	PIN LYNCH 1/4 X 1-1/4	1
12	6D529	CLEVIS PIN, 1.0 X 4.5	1
13	1-654-010059-17	SCREW, HX CP 5/8-11UNC X 6, GR5	2
14	1-512-010007-11	NUT, HEX 5/8-11 GR2, ZP	8
15	198951	PLATE UPPER HITCH CLAMP	1
16	198944	BRACKET WLDMT, UPPER HITCH	1
17	198938	BRACKET WLDMT, LH LOWER HITCH	1
18	198939	BRACKET WLDMT, RH LOWER HITCH	1
19	108841	PIN, LOWER 3-POINT	2
20	6D271	1 FT. EXTENSION ASSEMBLY (9' MODELS ONLY)	2
21	1-654-010059-05	SCREW, HEX CAP 5/8-11UNC X 2, GR5	8
22	1-861-010034-15	WASHER, LKG HLCL SPR, 5/8	8
23	2P151	SMV W/BRACKET	1
24	1-654-010049-05	SCREW, HX CP 5/16-18UNC X 1, GR5	2
25	1-861-010032-09	WASHER, FLAT 5/16 W ZP/CD	2
26	104032	NUT, HX SLF-LKG W/MYL 5/16-18	2
27	164678	MOUNT, SMV	1
28	3J562	U-BOLT 1/2-13 X 5-1/2 X 4-9/16	1
29	2P253	NUT, FLANGE NY-LOK 1/2-13	2
30	1-512-010005-13	NUT, HEX SLFLKG GRB 5/8-11	10
31	5D157	SLEEVE	1
32	2-557-010417	PIN, LYNCH CAT III	2

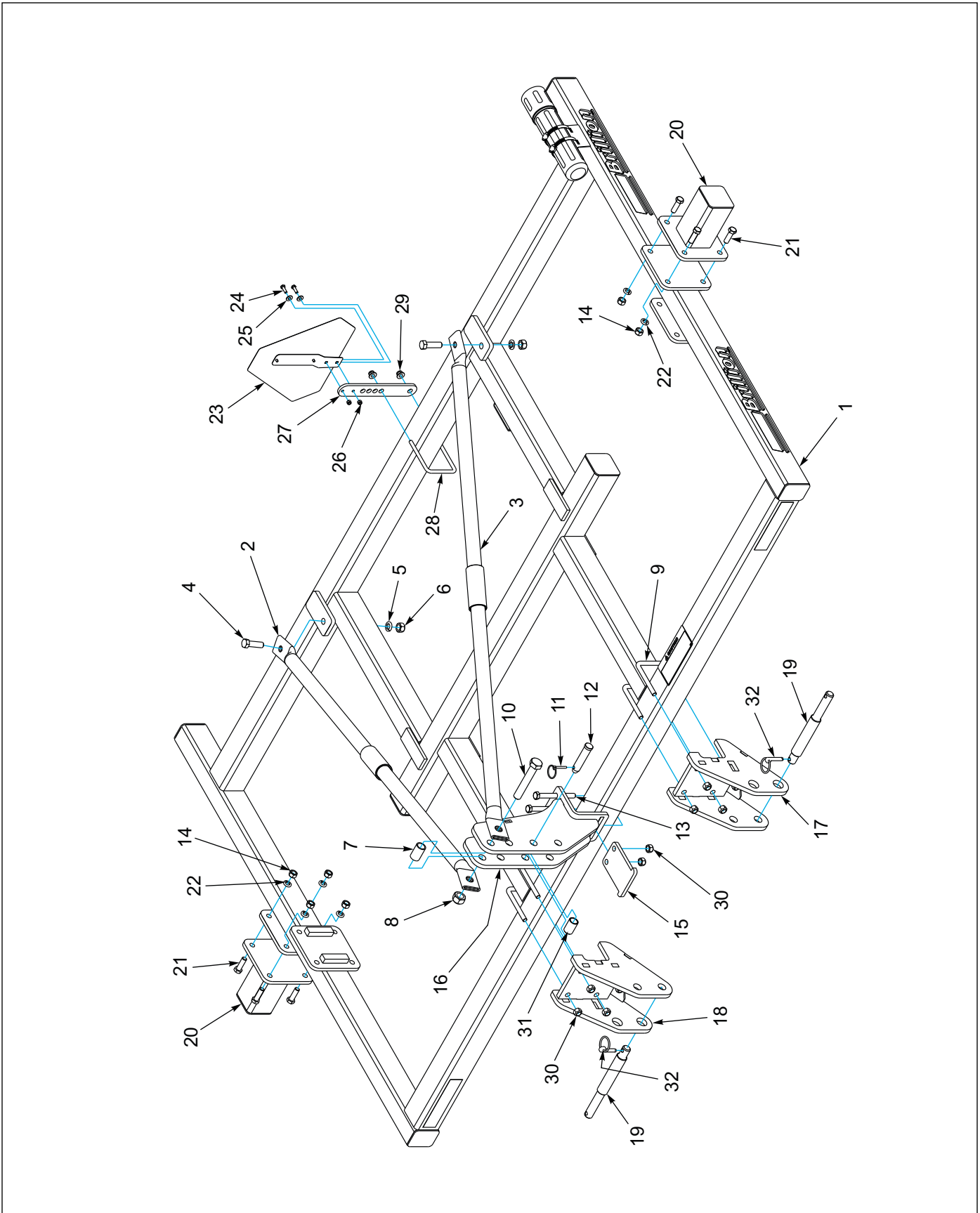

Figure 1-3: Frame 10 and 12 Shank Models

Frame 10 and 12 Shank Models

ITEM	PART NUMBER	DESCRIPTION	QTY
1	7D442	FRAME WELDMENT	1
2	7D472	R. H. BRACE	1
3	7D473	L. H. BRACE	1
4	1-654-010061-07	SCREW, HX CP 3/4-10UNC X 2-1/2, G5	2
5	1-861-010034-17	WASHER, LKG,HLCL SPR, 3/4	2
6	1-512-010007-12	NUT, HEX 3/4-10 GR2, ZP	2
7	6D988	SPACER	1
8	1-512-010005-19	NUT, 1-8 HEX SLF-LOCKING GRB	1
9	9D989	U-BOLT, 5/8-11 X 5-5/8 X 4-11/16	4
10	1-654-10065-17	SCREW, HEX CAP, 1-8UNC X 6, GR5	1
11	1-557-010327	PIN LYNCH 1/4 X 1-1/4	1
12	6D529	CLEVIS PIN, 1.0 X 4.5	1
13	1-654-010059-17	SCREW, HX CP 5/8-11UNC X 6, GR5	2
14	1-512-010007-11	NUT, HEX 5/8-11 GR2, ZP	8
15	198951	PLATE UPPER HITCH CLAMP	1
16	198944	BRACKET WLDMT, UPPER HITCH	1
17	198938	BRACKET WLDMT, LH LOWER HITCH	1
18	198939	BRACKET WLDMT, RH LOWER HITCH	1
19	108841	PIN, LOWER 3-POINT	2
20	6D271	1 FT. EXTENSION ASSEMBLY (12' MODELS ONLY)	2
21	1-654-010059-05	SCREW, HEX CAP 5/8-11UNC X 2, GR5	8
22	1-861-010034-15	WASHER, LKG HLCL SPR, 5/8	8
23	2P151	SMV W/BRACKET	1
24	1-654-010049-05	SCREW, HX CP 5/16-18UNC X 1, GR5	2
25	1-861-010032-09	WASHER, FLAT 5/16 W, ZP/CD	2
26	104032	NUT, HX SLF-LKG W/MYL 5/16-18	2
27	164678	MOUNT, SMV	1
28	3J562	U-BOLT 1/2-13 X 5-1/2 X 4-9/16	1
29	2P253	NUT, FLANGE NY-LOK 1/2-13	2
30	1-512-010005-13	NUT, HEX SLFLKG GRB 5/8-11	10
31	5D157	SLEEVE	1
32	2-557-010417	PIN, LYNCH CAT III	2

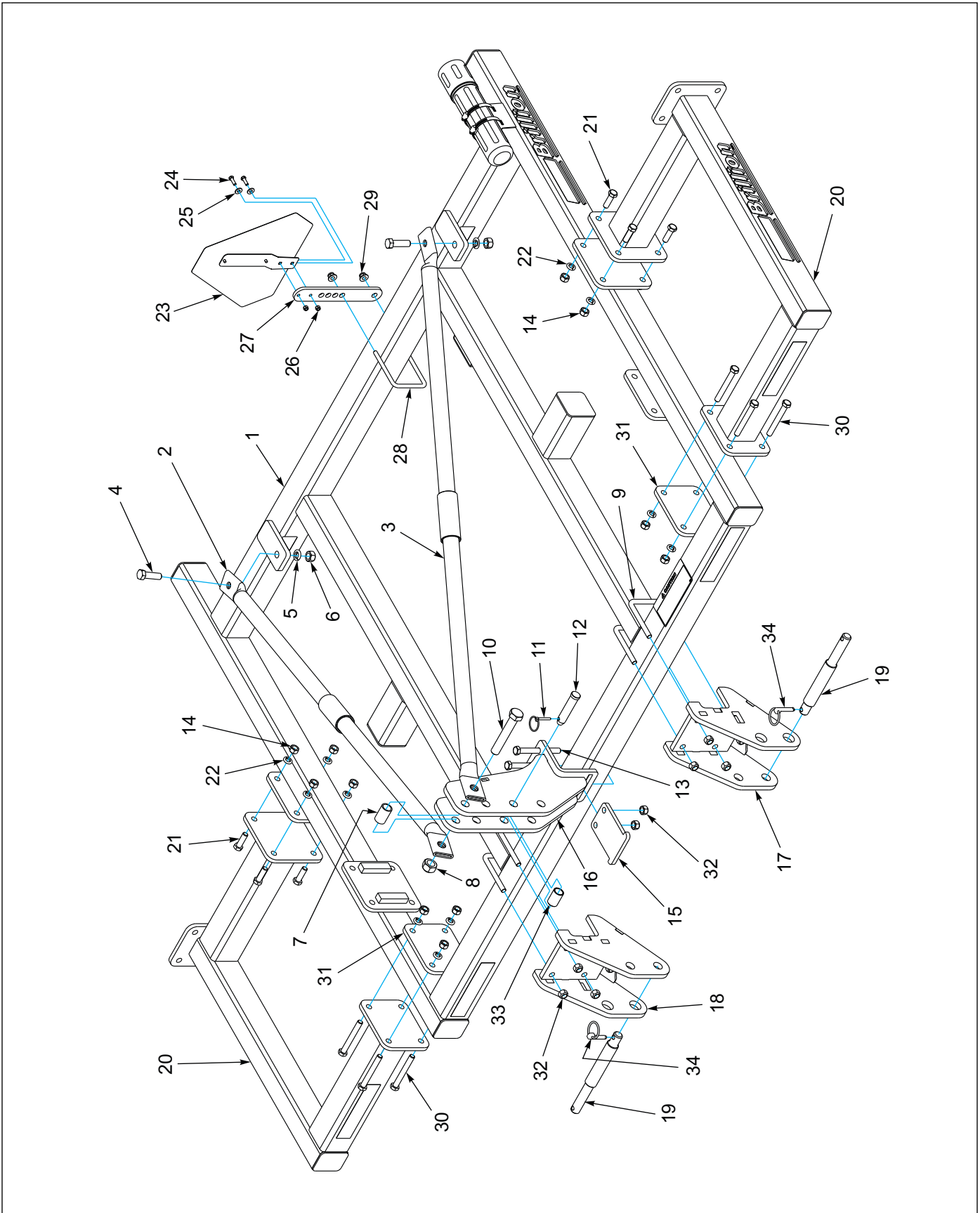

Figure 1-4: Frame 11 Shank Model

Frame 11 Shank Model

ITEM	PART NUMBER	DESCRIPTION	QTY
1	7D017	FRAME WELDMENT	1
2	7D472	R. H. BRACE	1
3	7D473	L. H. BRACE	1
4	1-654-010061-07	SCREW, HX CP 3/4-10UNC X 2-1/2, G5	2
5	1-861-010034-17	WASHER, LKG, HLCL SPR, 3/4	2
6	1-512-010007-12	NUT, HEX 3/4-10 GR2, ZP	2
7	6D988	SPACER	1
8	1-512-010005-19	NUT, 1-8 HEX SLF-LOCKING GRB	1
9	9D989	U-BOLT, 5/8-11 X 5-5/8 X 4-11/16	4
10	1-654-10065-17	SCREW, HEX CAP, 1-8UNC X 6, GR5	1
11	1-557-010327	PIN LYNCH 1/4 X 1-1/4	1
12	6D529	CLEVIS PIN, 1.0 X 4.5	1
13	1-654-010059-17	SCREW, HX CP 5/8-11UNC X 6, GR5	2
14	1-512-010007-11	NUT, HEX 5/8-11 GR2, ZP	16
15	198951	PLATE UPPER HITCH CLAMP	1
16	198944	BRACKET WLDMT, UPPER HITCH	1
17	198938	BRACKET WLDMT, LH LOWER HITCH	1
18	198939	BRACKET WLDMT, RH LOWER HITCH	1
19	108841	PIN, LOWER 3-POINT	2
20	6D273	2 FT. EXTENSION ASSEMBLY	2
21	1-654-010059-05	SCREW, HEX CAP 5/8-11UNC X 2, GR5	8
22	1-861-010034-15	WASHER, LKG HLCL SPR, 5/8	16
23	2P151	SMV W/BRACKET	1
24	1-654-010049-05	SCREW, HX CP 5/16-18UNC X 1, GR5	2
25	1-861-010032-09	WASHER, FLAT 5/16 W, ZP/CD	2
26	104032	NUT, HX SLF-LKG W/MYL 5/16-18	2
27	164678	MOUNT, SMV	1
28	3J562	U-BOLT 1/2-13 X 5-1/2 X 4-9/16	1
29	2P253	NUT, FLANGE NY-LOK 1/2-13	2
30	1-654-010059-15	SCREW, HEX CAP 5/8-11UNC X 5, GR5	8
31	6D299	PLATE	2
32	1-512-010005-13	NUT, HEX SLFLKG GRB 5/8-11	10
33	5D157	SLEEVE	1
34	2-557-010417	PIN, LYNCH CAT III	2

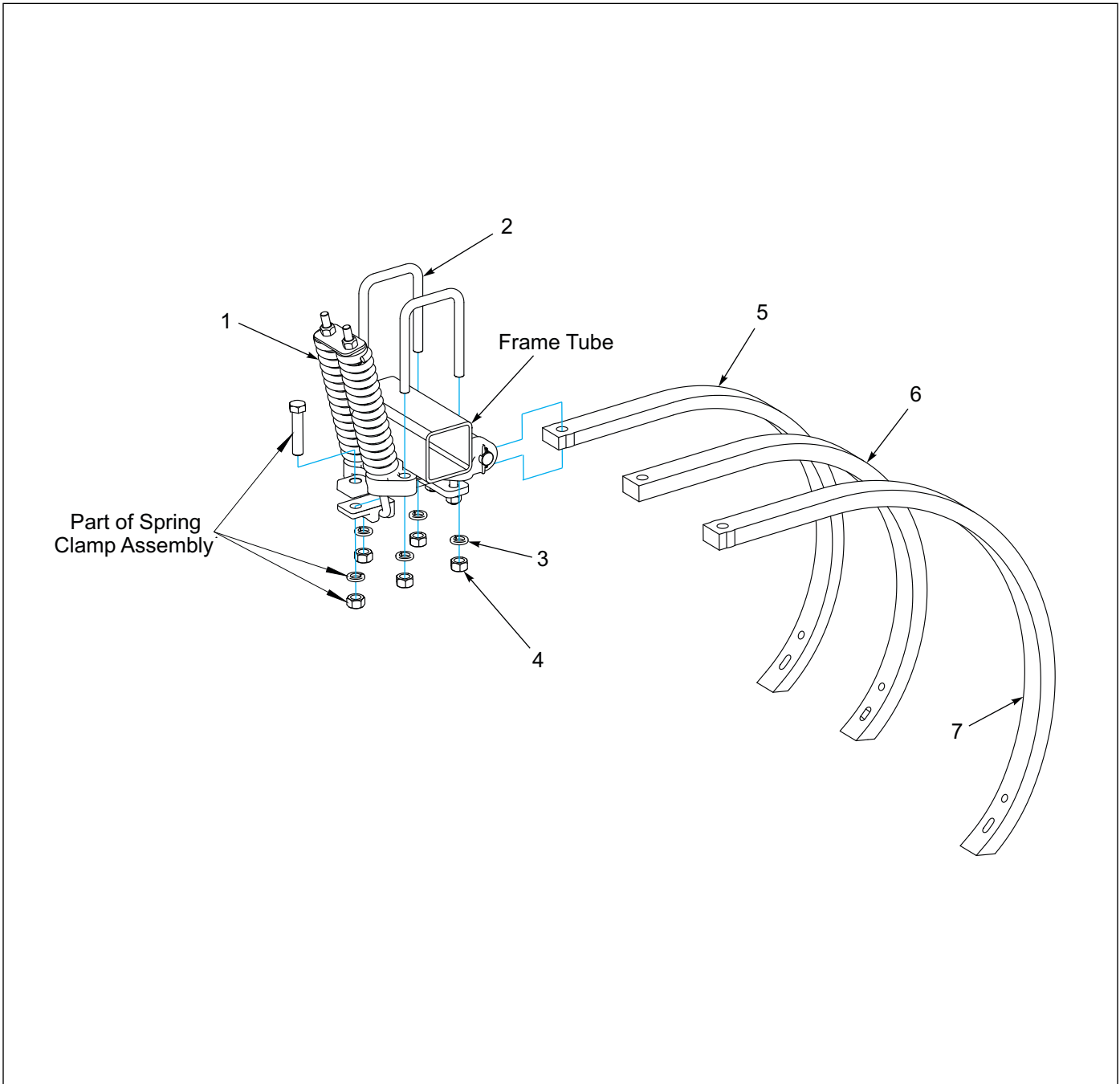

Figure 1-5: Shank and Spring Clamp Assembly

Shank and Spring Clamp Assembly

ITEM	PART NUMBER	DESCRIPTION	QTY
1	4J681	SPRING CLAMP ASM (SEE FIGURE 1-6)	1
2	4J293	U-BOLT, 3/4-10 X 6-3/8 X 4-3/4	2
3	1-861-010034-17	WASHER, LKG, HLCL, SPR, 3/4	4
4	1-512-010007-12	NUT, HEX 3/4-10 GR2, ZP	4
5	6D283	SHANK - 26S	1
6	2J644	SHANK	1
7	6D913	SHANK 32T	1

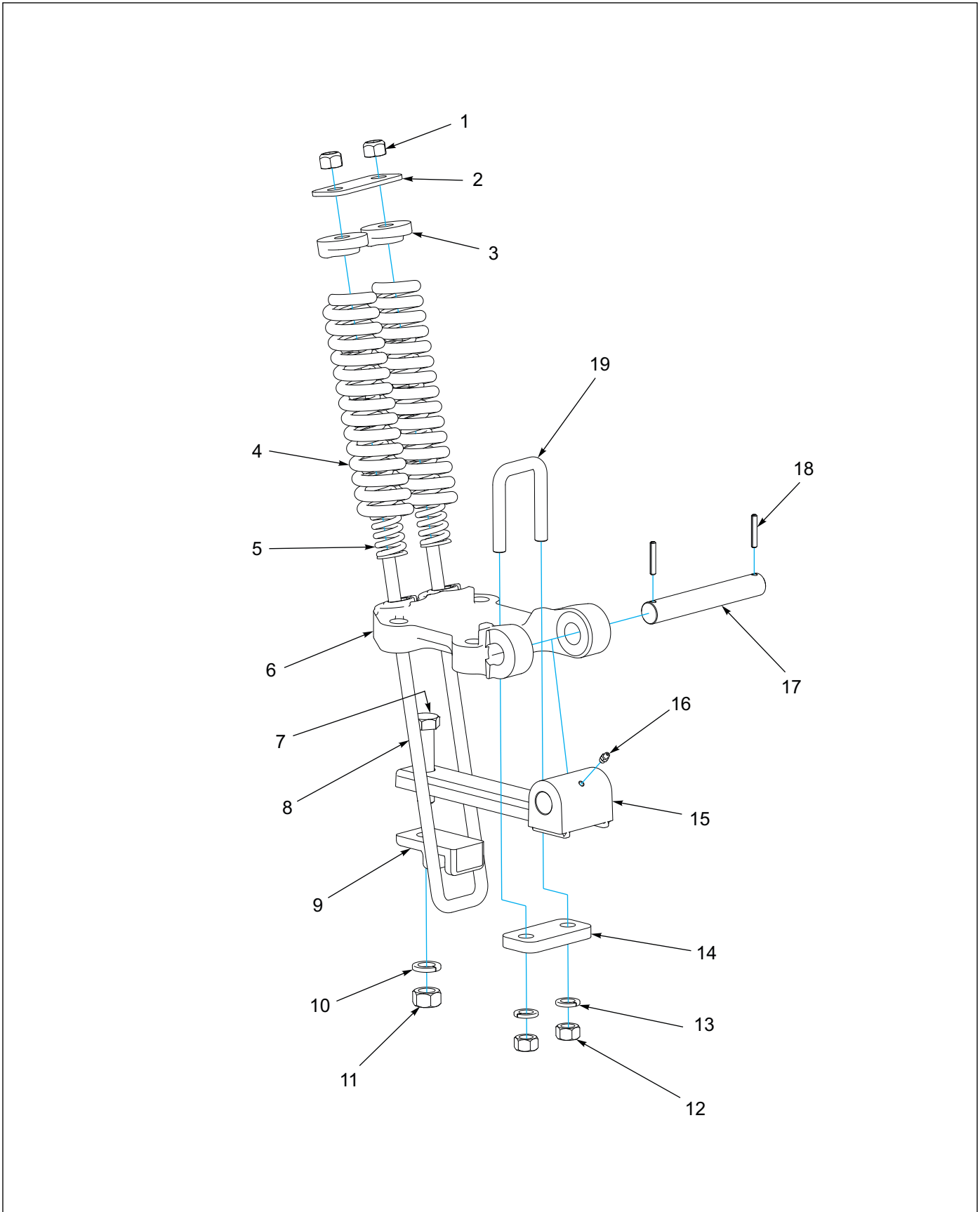

Figure 1-6: Spring Shank Assembly

Spring Shank Assembly

ITEM	PART NUMBER	DESCRIPTION	QTY
	4J681	SPRING CLAMP ASM	
1	1-512-010005-13	NUT, HEX, SLFLKG GRB 5/8-11	2
2	6D409	STRAP	1
3	6J459	CAP	2
4	4K076	COMPRESSION SPRING - OUTER	2
5	6D362	COMPRESSION SPRING - INNER	2
6	4J675	SHANK CLAMP	1
7	141776	SCREW, HXCP 3/4-10UNC X 3-1/2, GR5	1
8	2J096	U-BOLT, 5/8-11 X 16 X 2-3/4, ZP	1
9	2J091	U-BOLT, CLIP	1
10	1-861-010034-17	WASHER, LKG, HLCL SPR, 3/4	1
11	1-512-010007-12	NUT, HEX 3/4-10 GR2, ZP	1
12	1-512-010007-11	NUT, HEX 5/8-11 GR2, ZP	2
13	1-861-010034-15	WASHER, LKG HLCL SPR, 5/8	2
14	6D280	STRAP	1
15	2J092	SHANK HOLDER	1
16	1-298-010001-1	ZERK FITTING 1/4 SAE	1
17	8J130	PIN, 1.0 X 6.875 PLATED	1
18	1-647-010004217	ROLL PIN 1/4 X 1-1/2	2
19	2J094	U-BOLT, 5/8-11 X 3-3/8 X 2-5/8	1

ILLUSTRATED PARTS LIST

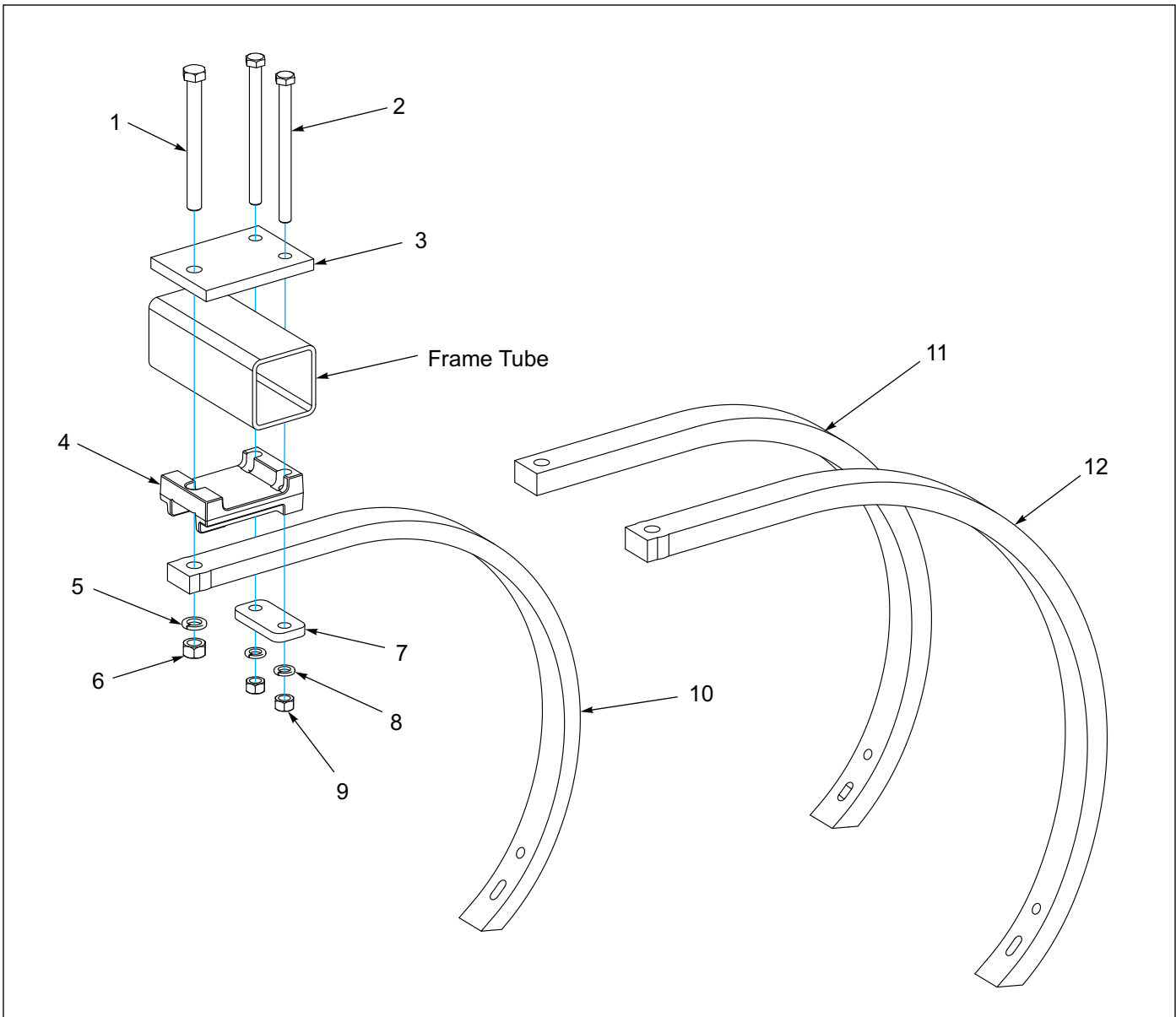

Figure 1-7: Rigid Shank Assembly

Rigid Shank Assembly

ITEM	PART NUMBER	DESCRIPTION	QTY
1	1-654-010061-20	SCREW, HX CP 3/4-10UNC X 7-1/2, G5	1
2	1-654-010059-21	SCREW, HEX CAP 5/8-11UNC X 8, GR5	2
3	6D298	PLATE	1
4	6D234	SHANK SUPPORT	1
5	1-861-010034-17	WASHER, LKG HLCL SPR, 3/4	1
6	1-512-010007-12	NUT, HEX 3/4-10	1
7	6D280	STRAP	1
8	1-861-010034-15	WASHER, LKG,HLCL SPR, 5/8	2
9	1-512-010007-13	NUT, HEX 5/8-11	2
10	6D283	SHANK - 26S	1
11	2J644	SHANK	1
12	6D913	SHANK 32T	1

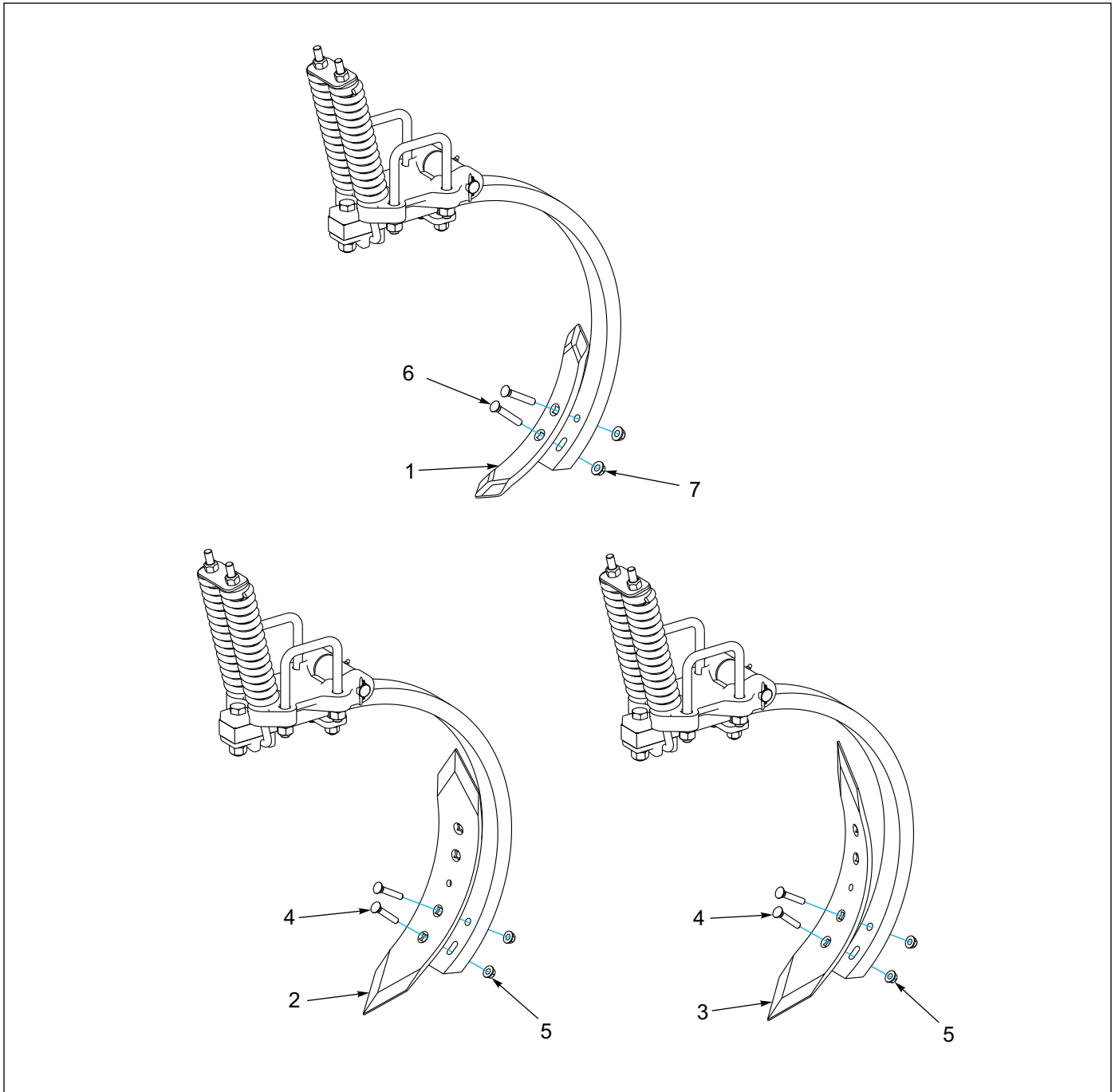

Figure 1-8: Points

Points

ITEM	PART NUMBER	DESCRIPTION	QTY
1	6D213	CHISEL POINT	1
2	6D216	REV. DBL.PT. TW SHOVEL (LEFT)	1
3	6D215	REV. DBL.PT. TW SHOVEL (RIGHT)	1
4	7K964	SPECIAL PLOW BOLT	2
5	4K551	SELF-LOCKING FLANGE NUT (7/16-14)	2
6	1/2-13X3PLOW	PLOW BOLT GR5	2
7	4K552	SELF-LOCKING FLANGENUT (1/2-13)	2

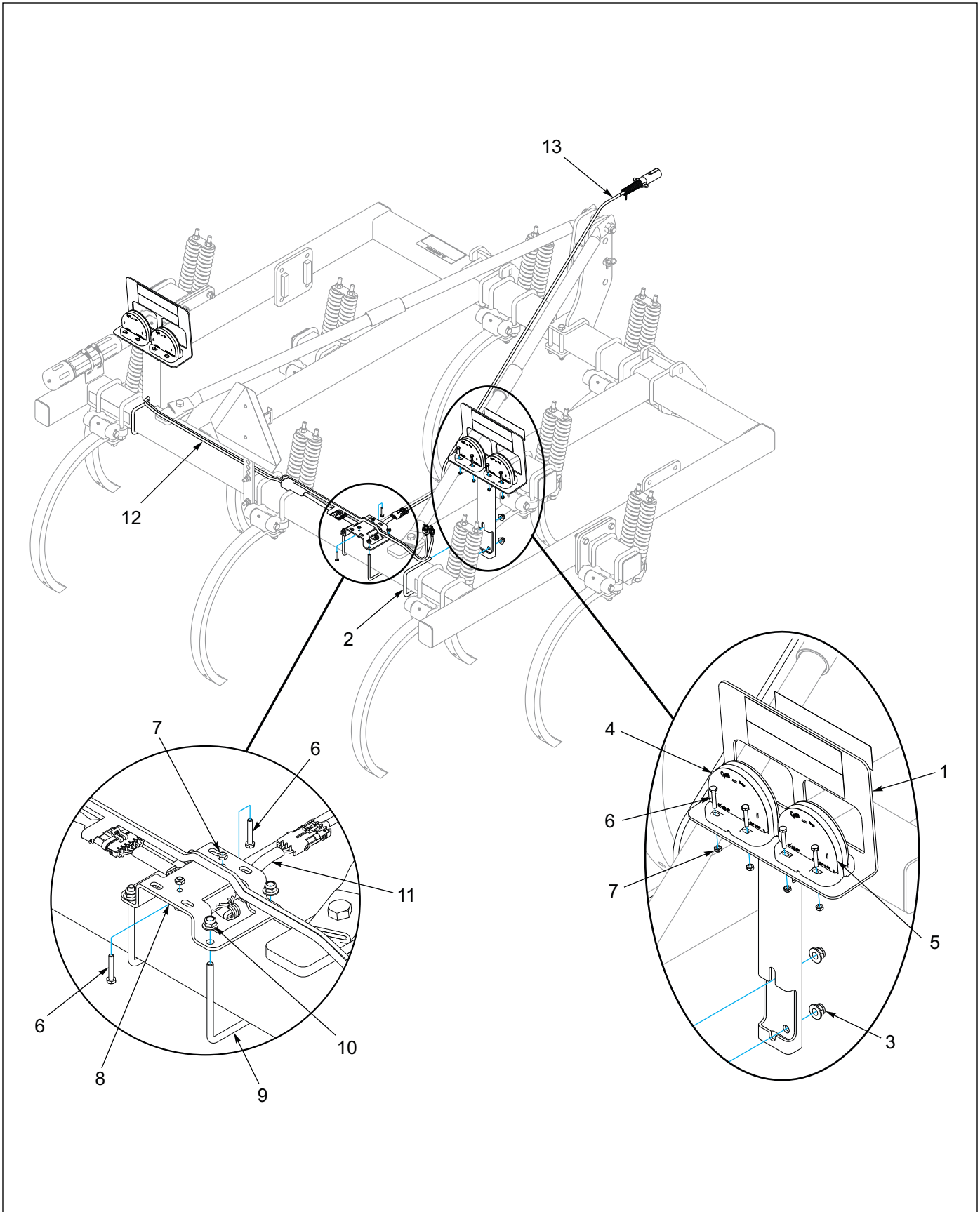

Figure 1-9: 7 and 9 Shank Models LED Warning Lights

7 and 9 Shank Models LED Warning Lights

ITEM	PART NUMBER	DESCRIPTION	QTY
1	178554	BRACKET WLDMT, LIGHT	2
2	3J562	U-BOLT, 1/2-13 X 5-1/2 X 4	2
3	2P253	NUT, FLANGE NY-LOK 1/2-13	4
4	174436	LAMP, AG AMBER SINGLE LED	2
5	174435	LAMP, AG RED SINGLE LED	2
6	1-654-010047-08	SCREW HX CP, 1/4-20UNC X 1-1/2, G5	18
7	1-512-010005-01	NUT, HEX, SLFLKG GRB 1/4-20	18
8	178506	BRACKET, MODULE MOUNT	1
9	178507	U-BOLT, 3/8-16 X 4-3/8 X 5, ZP	2
10	2P252	NUT, FLANGE NY-LOK 3/8-16	4
11	174437	MODULE, AG FLASHER CONTROL	1
12	178525	HARNESS, LAMP 84 X 84	1
13	178514	HARNESS, 7 PIN/4PIN WP, 10'	1

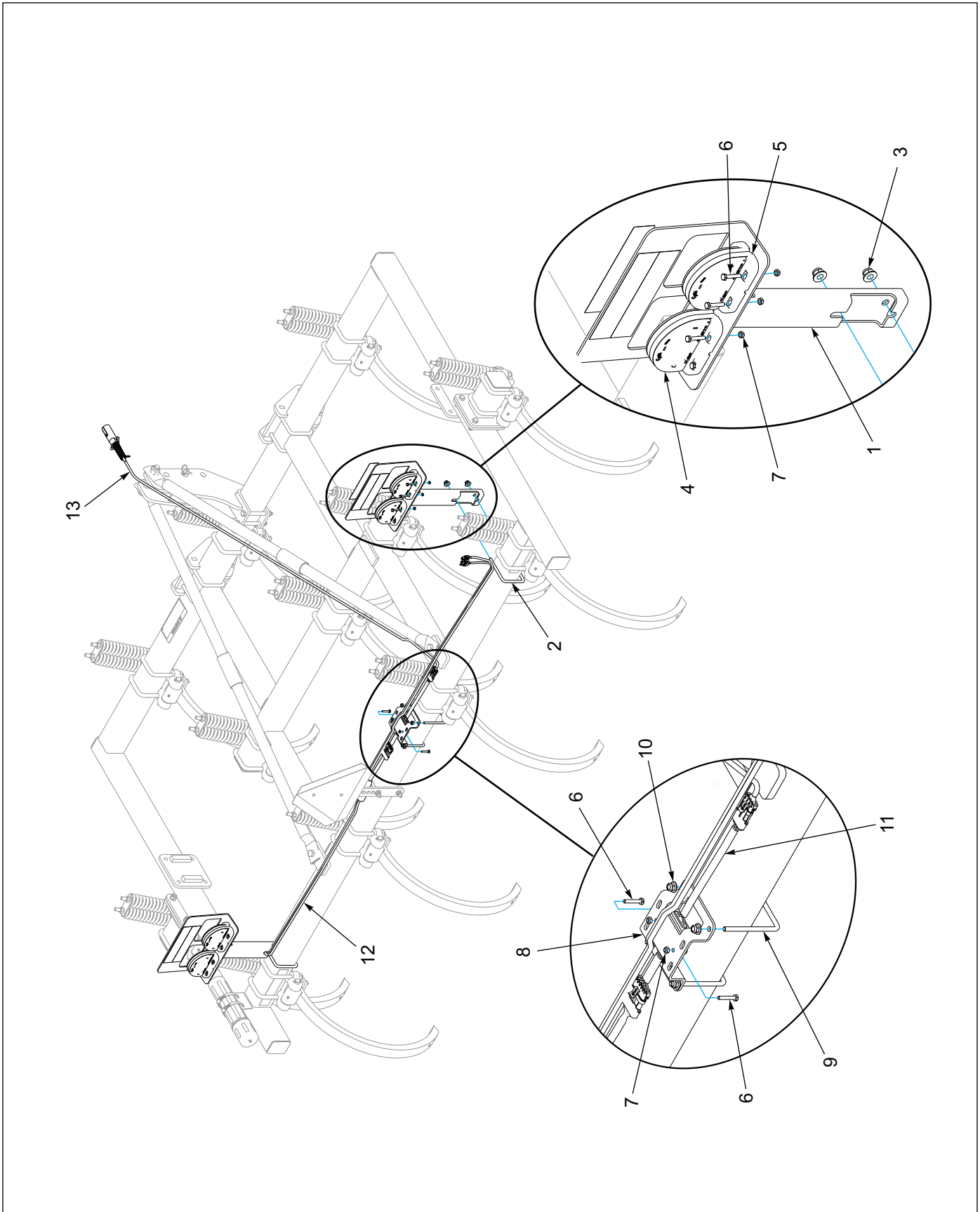

Figure 1-10: 10 and 12 Shank Models LED Warning Lights

10 and 12 Shank Models LED Warning Lights

ITEM	PART NUMBER	DESCRIPTION	QTY
1	178554	BRACKET WLDMT, LIGHT	2
2	3J562	U-BOLT, 1/2-13 X 5-1/2 X 4	2
3	2P253	NUT, FLANGE NY-LOK 1/2-13	4
4	174436	LAMP, AG AMBER SINGLE LED	2
5	174435	LAMP, AG RED SINGLE LED	2
6	1-654-010047-08	SCREW, HX CP, 1/4-20UNC X 1-1/2, G5	18
7	1-512-010005-01	NUT, HEX,SLFLKG GRB 1/4-20	18
8	178506	BRACKET, MODULE MOUNT	1
9	178507	U-BOLT, 3/8-16 X 4-3/8 X 5, ZP	2
10	2P252	NUT, FLANGE NY-LOK 3/8-16	4
11	174437	MODULE, AG FLASHER CONTROL	1
12	178525	HARNESS, LAMP 84 X 84	1
13	178514	HARNESS, 7 PIN/4PIN WP, 10'	1

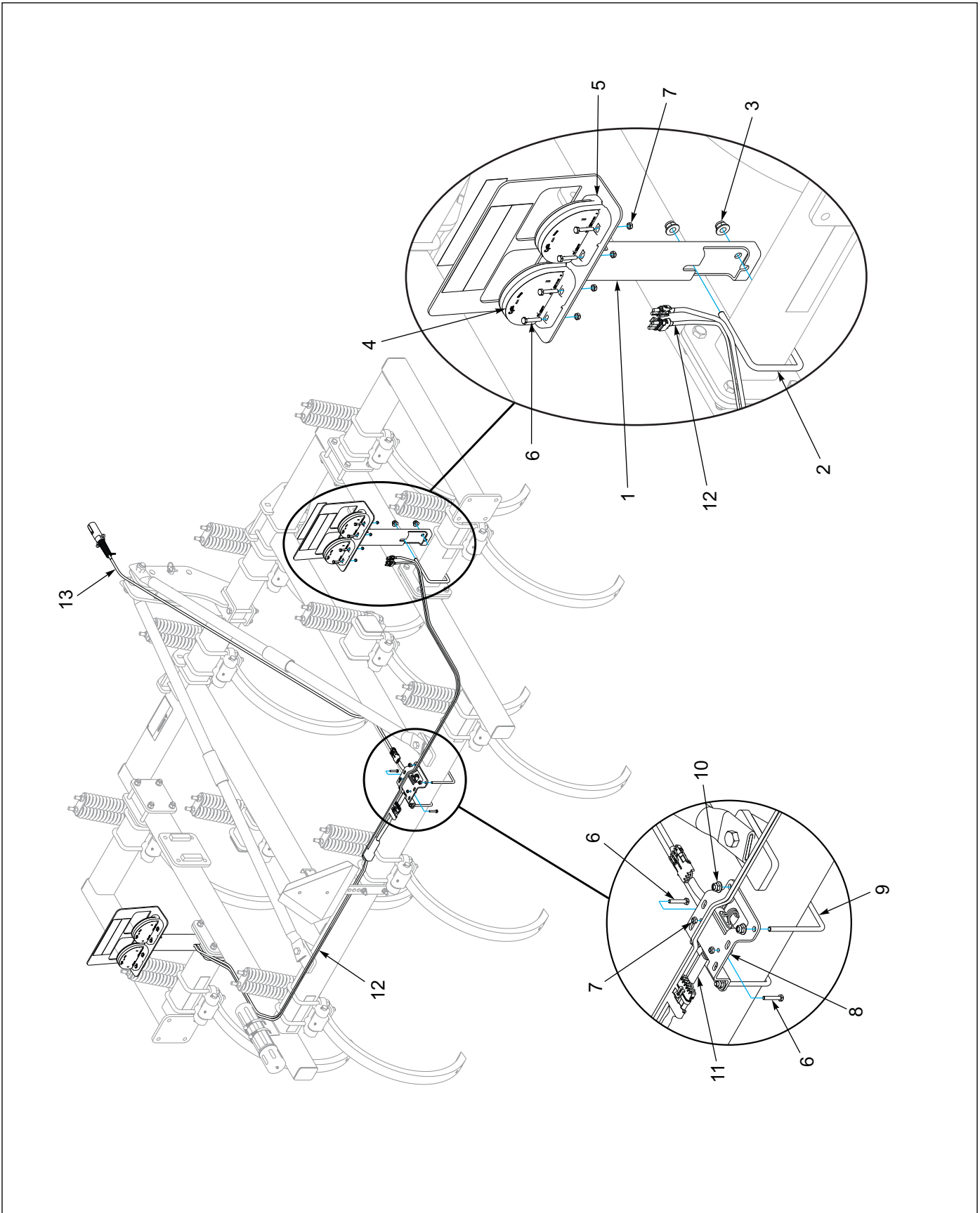

Figure 1-11: 11 Shank Model LED Warning Lights

11 Foot Shank LED Warning Lights

ITEM	PART NUMBER	DESCRIPTION	QTY
1	178554	BRACKET WLDMT, LIGHT	2
2	3J562	U-BOLT, 1/2-13 X 5-1/2 X 4	2
3	2P253	NUT, FLANGE NY-LOK 1/2-13	4
4	174436	LAMP, AG AMBER SINGLE LED	2
5	174435	LAMP, AG RED SINGLE LED	2
6	1-654-010047-08	SCREW HX CP, 1/4-20UNC X 1-1/2, G5	18
7	1-512-010005-01	NUT, HEX, SLFLKG GRB 1/4-20	18
8	178506	BRACKET, MODULE MOUNT	1
9	178507	U-BOLT, 3/8-16 X 4-3/8 X 5, ZP	2
10	2P252	NUT, FLANGE NY-LOK 3/8-16	4
11	174437	MODULE, AG FLASHER CONTROL	1
12	178525	HARNESS, LAMP 84 X 84	1
13	178514	HARNESS, 7 PIN/4PIN WP, 10'	1

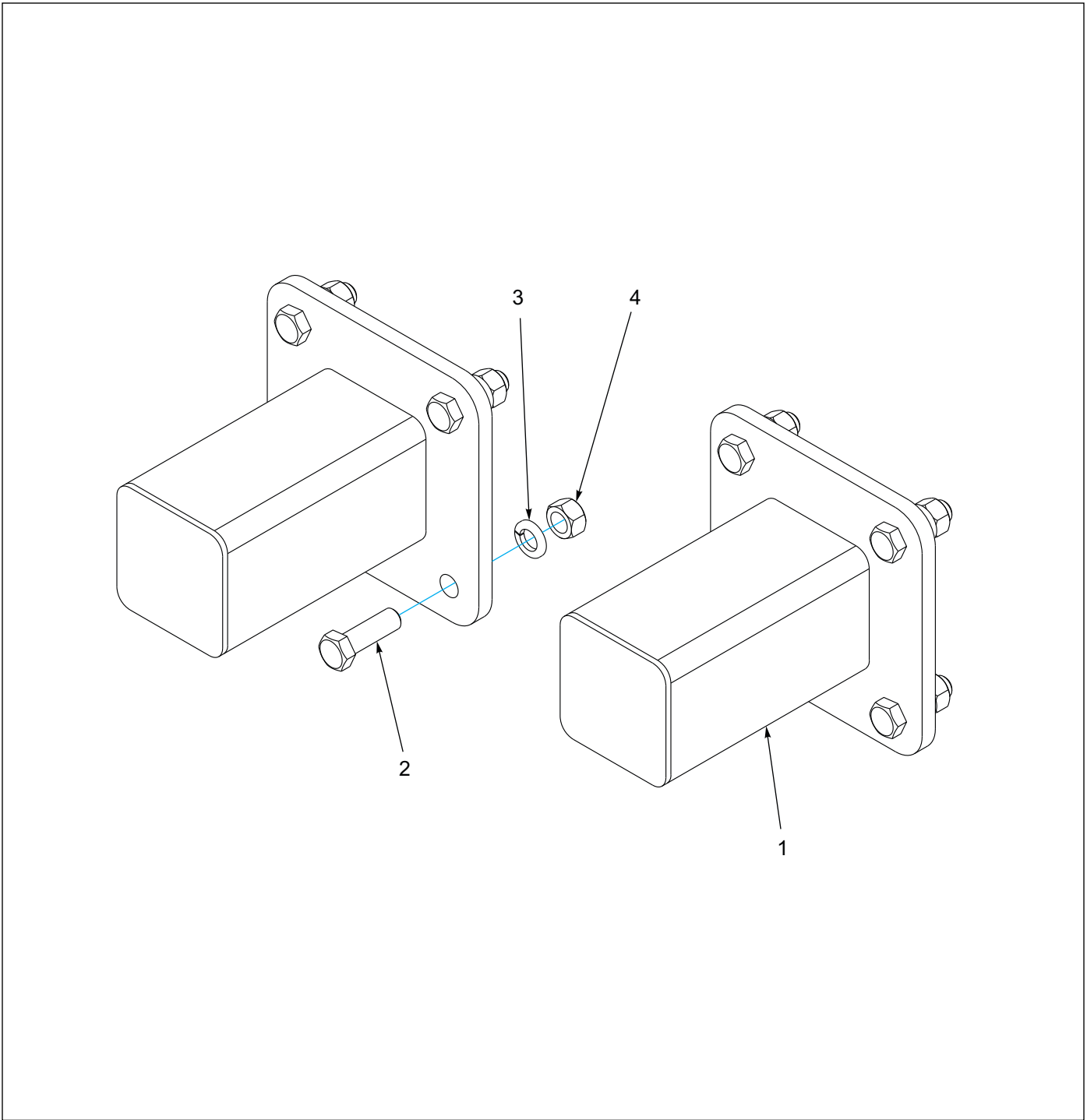

Figure 1-12: 2 Foot Optional Extension Kit

2 Foot Optional Extension Kit

ITEM	PART NUMBER	DESCRIPTION	QTY
	6D226	KIT, 2 FT EXTENSION	
1	6D271	1 FT. EXTENSION ASSEMBLY	2
2	1-654-010059-05	SCREW, HEX CAP, 5/8-11UNC X 2, GR5	8
3	1-861-010034-15	WASHER, LKG,HLCL SPR, 5/8	8
4	1-512-010007-11	NUT, HEX 5/8-11 GR2, ZP	8

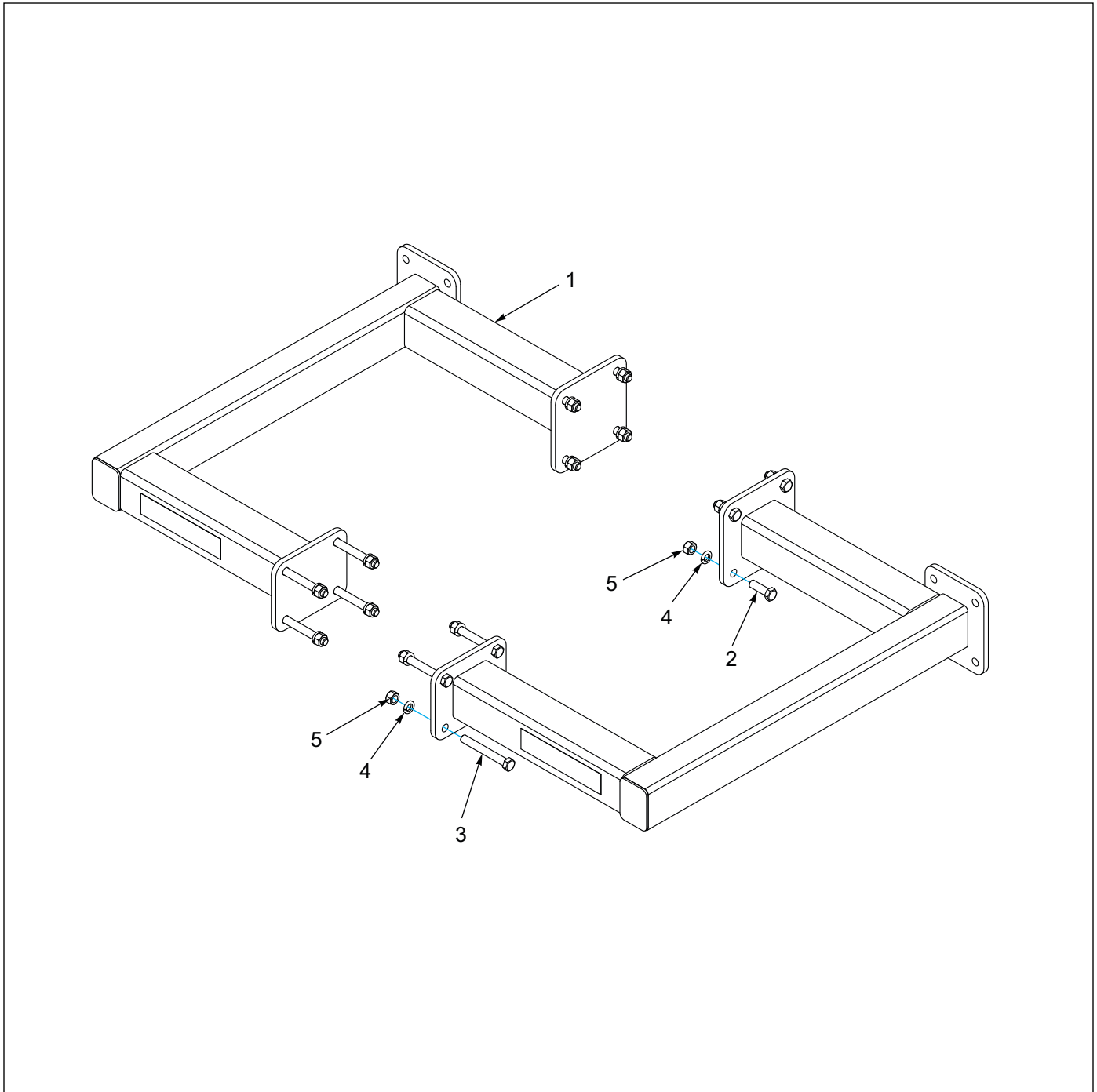

Figure 1-13: 4 Foot Optional Extension Kit

4 Foot Optional Extension Kit

ITEM	PART NUMBER	DESCRIPTION	QTY
	6D227	KIT, 4FT EXTENSION	
1	6D273	2 FT. EXTENSION ASSEMBLY	2
2	1-654-010059-05	SCREW, HEX CAP, 5/8-11UNC X 2, GR5	8
3	1-654-010059-15	SCREW, HEX CAP, 5/8-11UNC X 5, GR5	8
4	1-861-010034-15	WASHER, LKG,HLCL SPR,5/8	16
5	1-512-010007-11	NUT, HEX 5/8-11 GR2, ZP	16

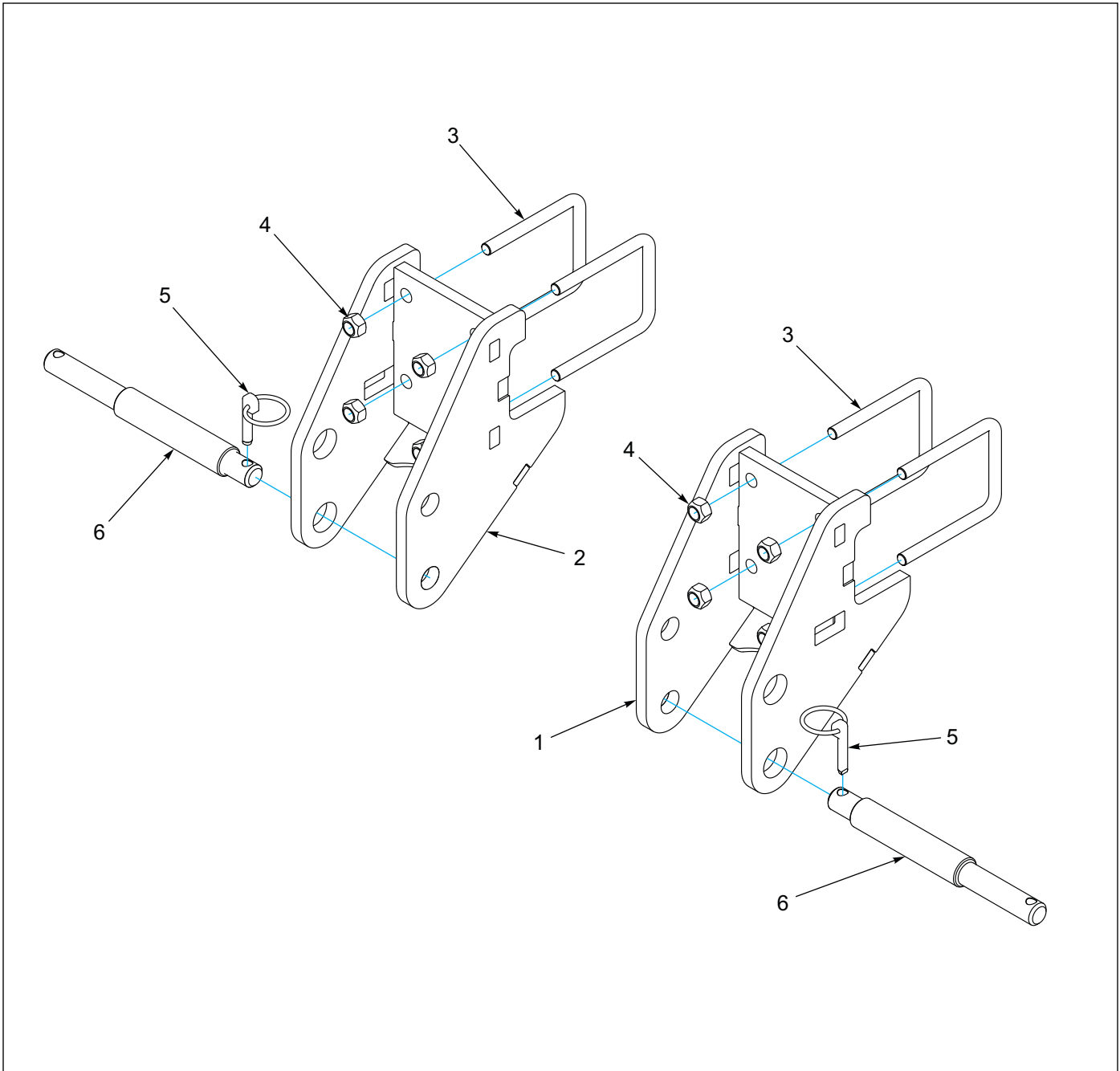

Figure 1-14: Optional Bracket Assemblies for Older Models (Prior to April 2016)

Optional Bracket Assemblies for Older Models (Prior to April 2016)

ITEM	PART NUMBER	DESCRIPTION	QTY
	198946	BRACKET ASM, LH LOWER HITCH (INCLUDES ITEMS 1,3-6)	
	198947	BRACKET ASM, RH LOWER HITCH (INCLUDES ITEMS 2-6)	
1	198938	BRACKET WLDMT, LH LOWER HITCH	1
2	198939	BRACKET WLDMT, RH LOWER HITCH	1
3	9D989	U-BLT, 5/8-11 X 4-11/16 X 5-5/8, ZP	4
4	1-512-010005-13	NUT, HEX SLFLKG GRB 5/8-11	8
5	2-557-010417	PIN, LYNCH CAT 3	2
6	108841	PIN, LOWER, 3-POINT	2

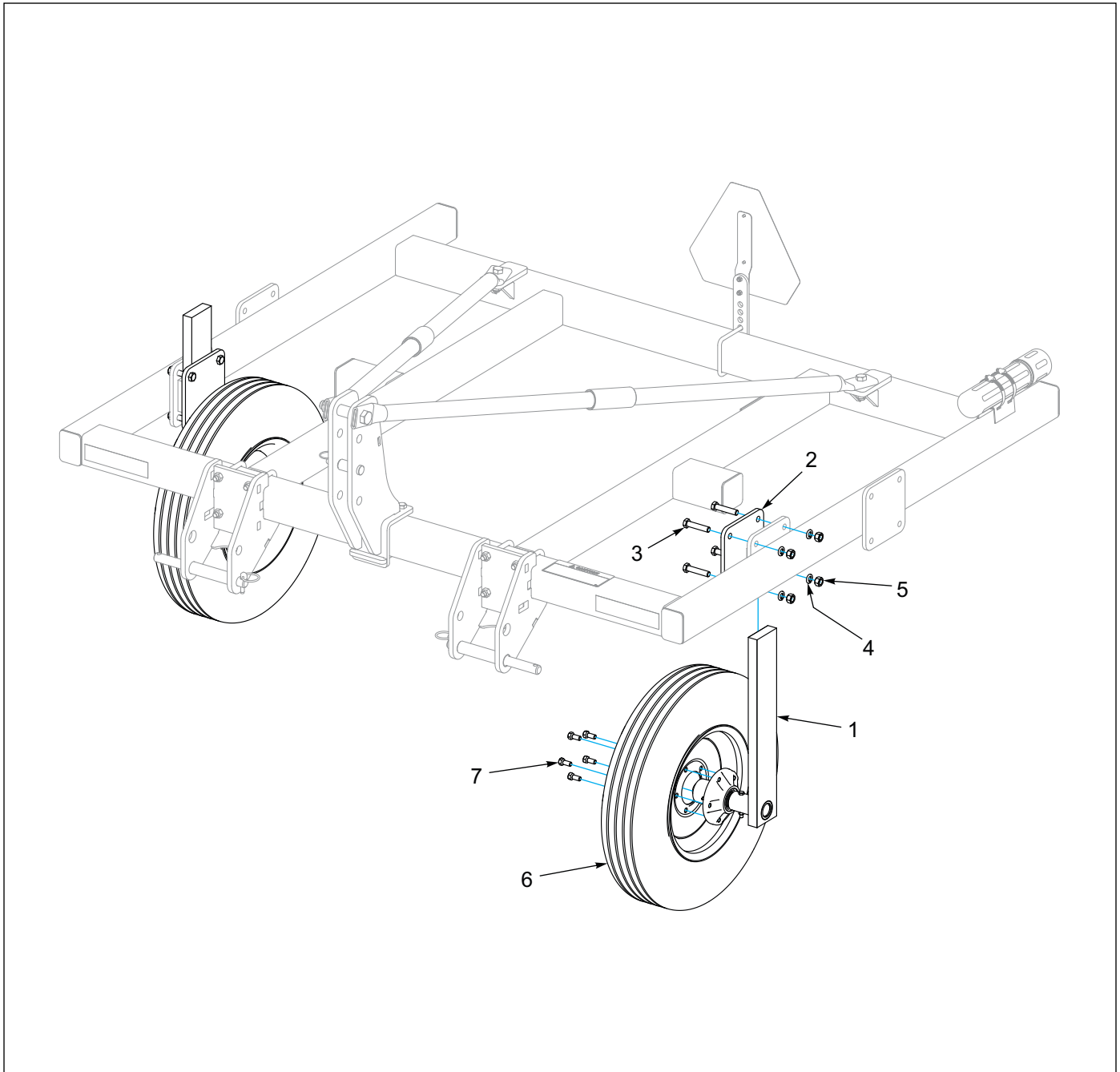

Figure 1-15: Optional Gauge Wheel Kit 32"

Optional Gauge Wheel Kit 32"

ITEM	PART NUMBER	DESCRIPTION	QTY
	6D946	32" GAUGE WHEEL KIT	
1	1J402	HUB & BAR ASSEMBLY(SEE FIGURE 1-17)	2
2	1J469	PLATE	2
3	1-654-010059-09	SCREW, 5/8-11UNC X 3 HX CP, GR5	8
4	1-861-010034-15	WASHER, LKG,HLCL SPR, 5/8	8
5	1-512-010007-11	NUT, HEX 5/8-11 GR2, ZP	8
6	6K911	WHEEL 8J789/NO TUBE/4C129 (SEE FIGURE 1-20)	2
7	5C100	WHEEL BOLT 1/2-20 X 1 GR5, ZP	10

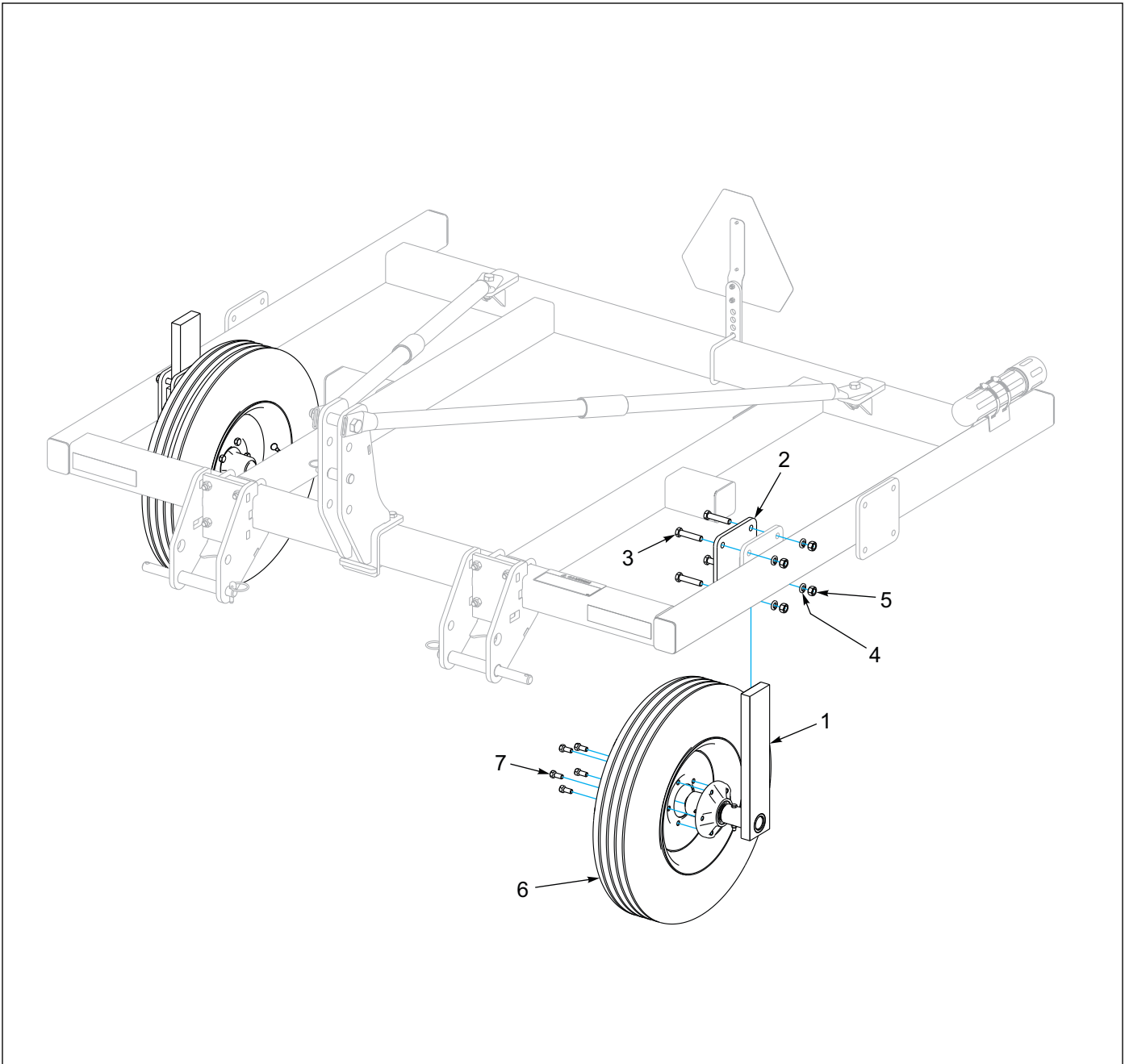

Figure 1-16: Optional Gauge Wheel Kit 26"

Optional Gauge Wheel Kit 26"

ITEM	PART NUMBER	DESCRIPTION	QTY
	7D441	26" GAUGE WHEEL KIT	
1	1J404	HUB & BAR ASSEMBLY (SEE FIGURE 1-18)	2
2	1J469	PLATE	2
3	1-654-010059-09	SCREW, 5/8-11UNC X 3 HX CP, GR5	8
4	1-861-010034-15	WASHER, LKG,HLCL SPR, 5/8	8
5	1-512-010007-11	NUT, HEX 5/8-11 GR2, ZP	8
6	6K911	WHEEL 8J789/NO TUBE/4C129 (SEE FIGURE 1-20)	2
7	5C100	WHEEL BOLT 1/2-20 X 1 GR5, ZP	10

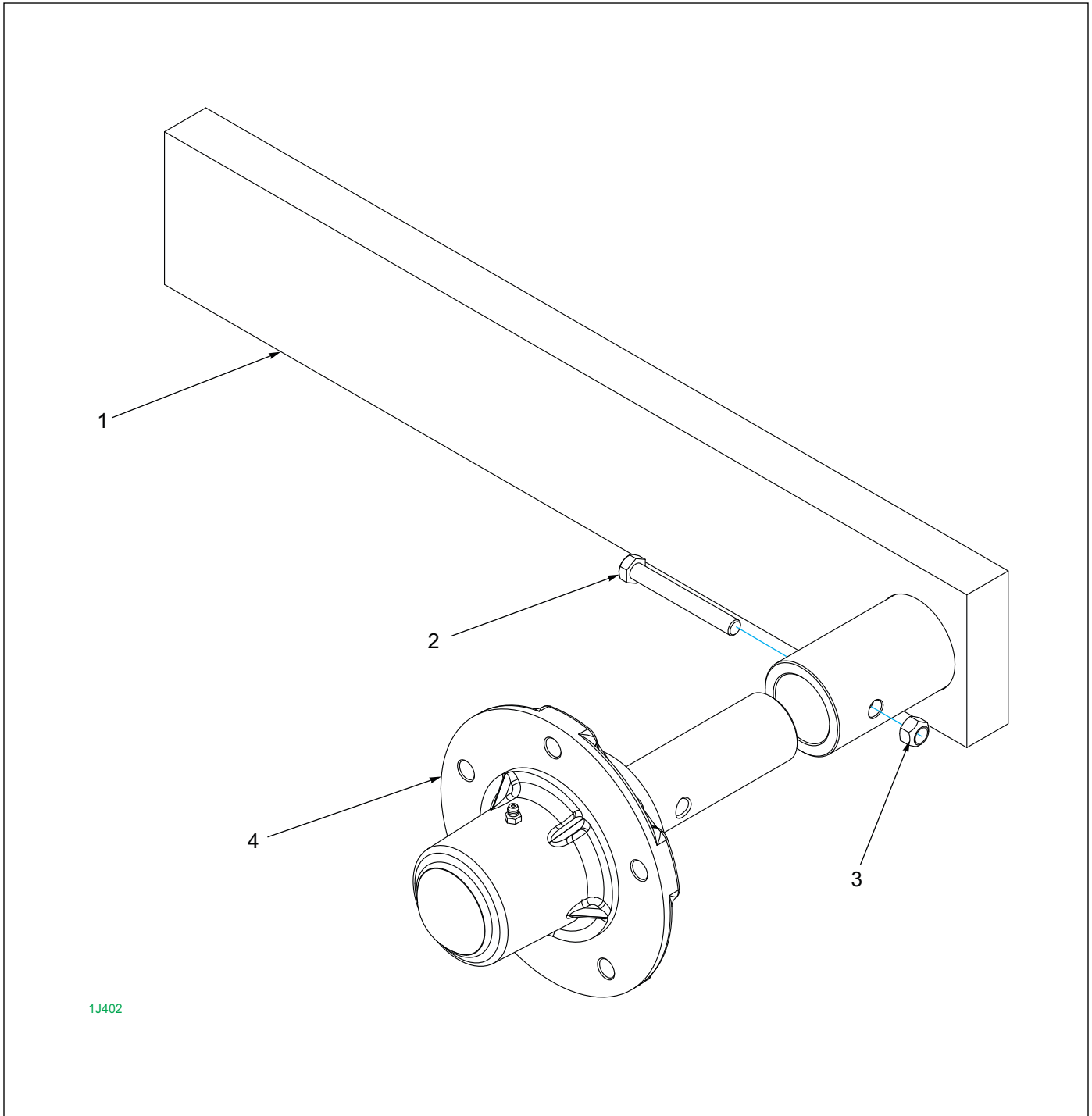

Figure 1-17: Hub and Bar Assembly

Hub and Bar Assembly

ITEM	PART NUMBER	DESCRIPTION	QTY
	1J402	HUB & BAR ASSEMBLY	
1	168344	ARM WELDMENT	1
2	1-654-010051-13	SCREW, HX CP, 3/8-16UNC X 3, GR5	1
3	1-512-010005-05	NUT, HEX, SLFLKG GRB 3/8-16	1
4	1J398	HUB & SPINDLE ASSEMBLY (SEE FIGURE 1-19)	1

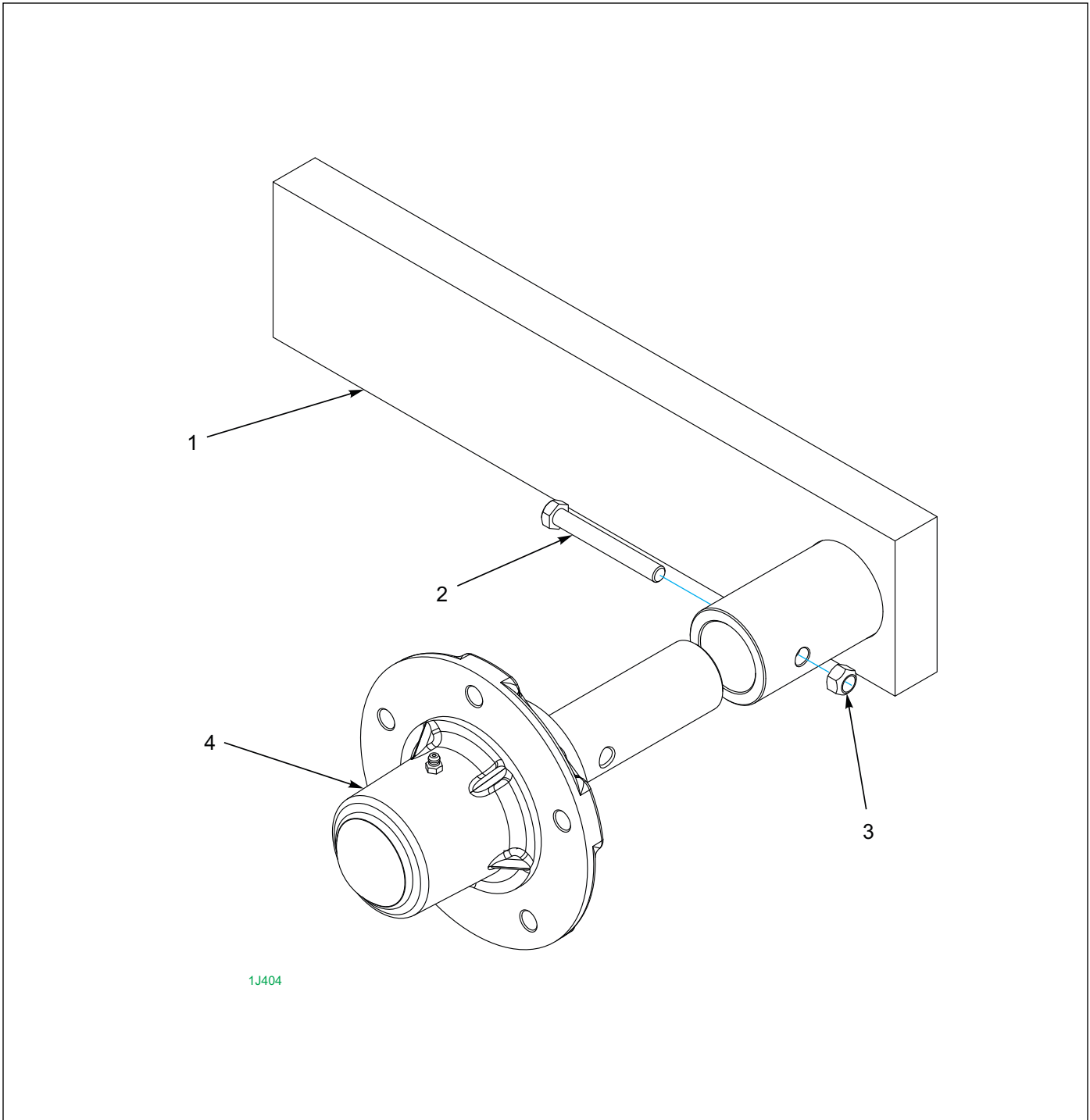

Figure 1-18: Hub and Bar Assembly

Hub and Bar Assembly

ITEM	PART NUMBER	DESCRIPTION	QTY
	1J404	HUB & BAR ASSEMBLY	
1	168345	ARM WELDMENT	1
2	1-654-010051-13	SCREW, HX CP, 3/8-16UNC X 3, GR5	1
3	1-512-010005-05	NUT, HEX, SLFLKG GRB 3/8-16	1
4	1J398	HUB & SPINDLE ASSEMBLY (SEE FIGURE 1-19)	1

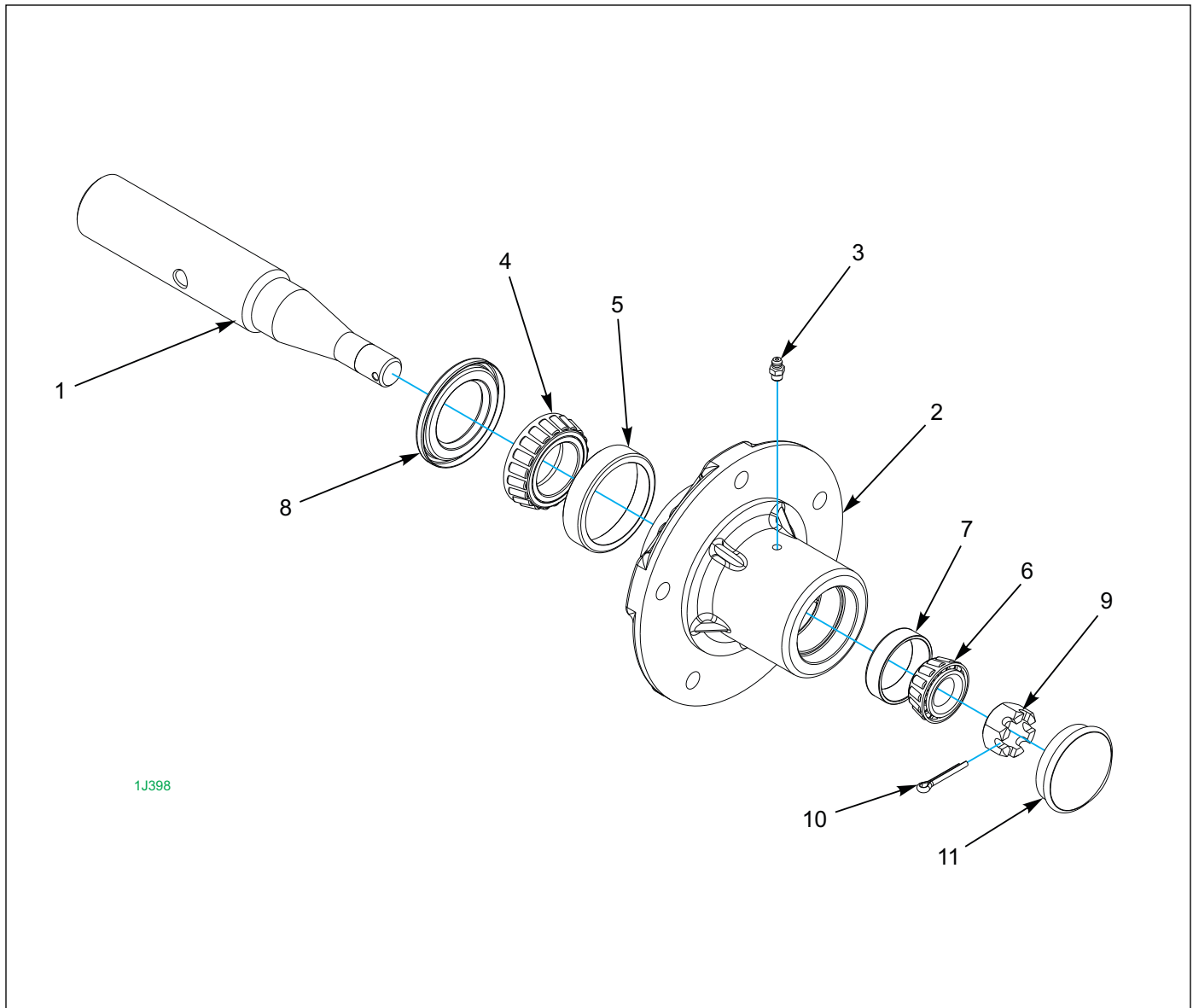

Figure 1-19: Hub and Spindle Assembly

Hub and Spindle Assembly

ITEM	PART NUMBER	DESCRIPTION	QTY
	1J398	HUB & SPINDLE ASSEMBLY	
1	1J377	SPINDLE	1
2	1J390	WHEEL HUB - 5 BOLT (INCLUDES ITEM 3)	1
3	1-298-010001-1	ZERK FITTING 1/4 SAE	1
4	712099	BRG CONE, TIMKEN LM48548	1
5	2107649	BRG CUP, TIMKEN LM48510	1
6	1-076-010008	BRG CONE, TIMKEN LM11949	1
7	5C912	BRG CUP, TIMKEN LM11910	1
8	1D273	SEAL, SINGLE LIP	1
9	3/4-16HSN	NUT, HX SLOT 3/4-16 HSN	1
10	110-0344	5/32 X 1 COTTER PIN	1
11	1J463	HUB CAP	1

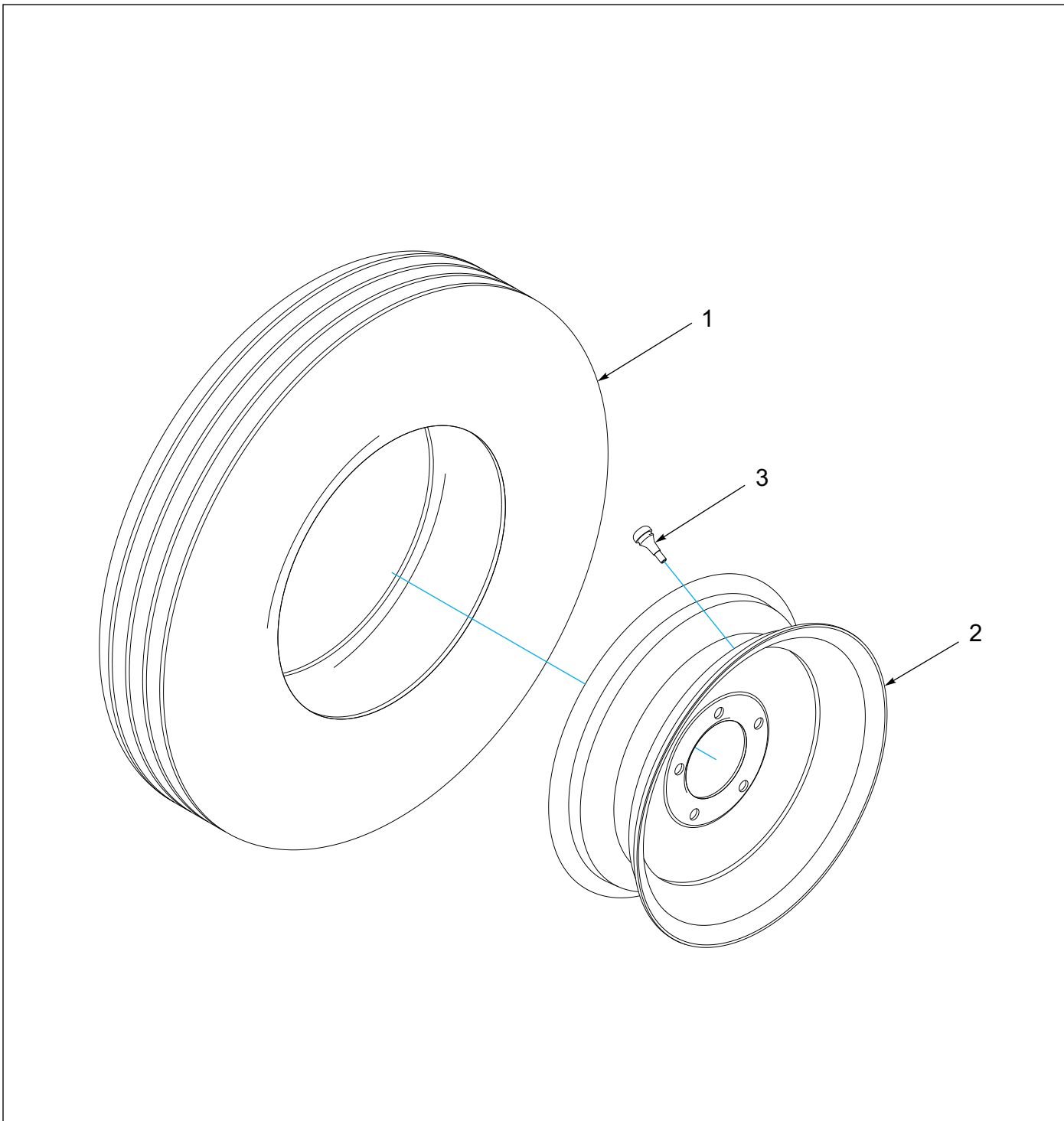

Figure 1-20: Wheel

Wheel

ITEM	PART NUMBER	DESCRIPTION	QTY
	6K911	WHEEL 8J789/NO TUBE/4C129	
1	8J789	TIRE - 7.60 X 15 - 6 PLY	1
2	4C129	WHEEL - 15 X 5KB - 5 BOLT	1
3	415	VAVLE STEM	1

ILLUSTRATED PARTS LIST

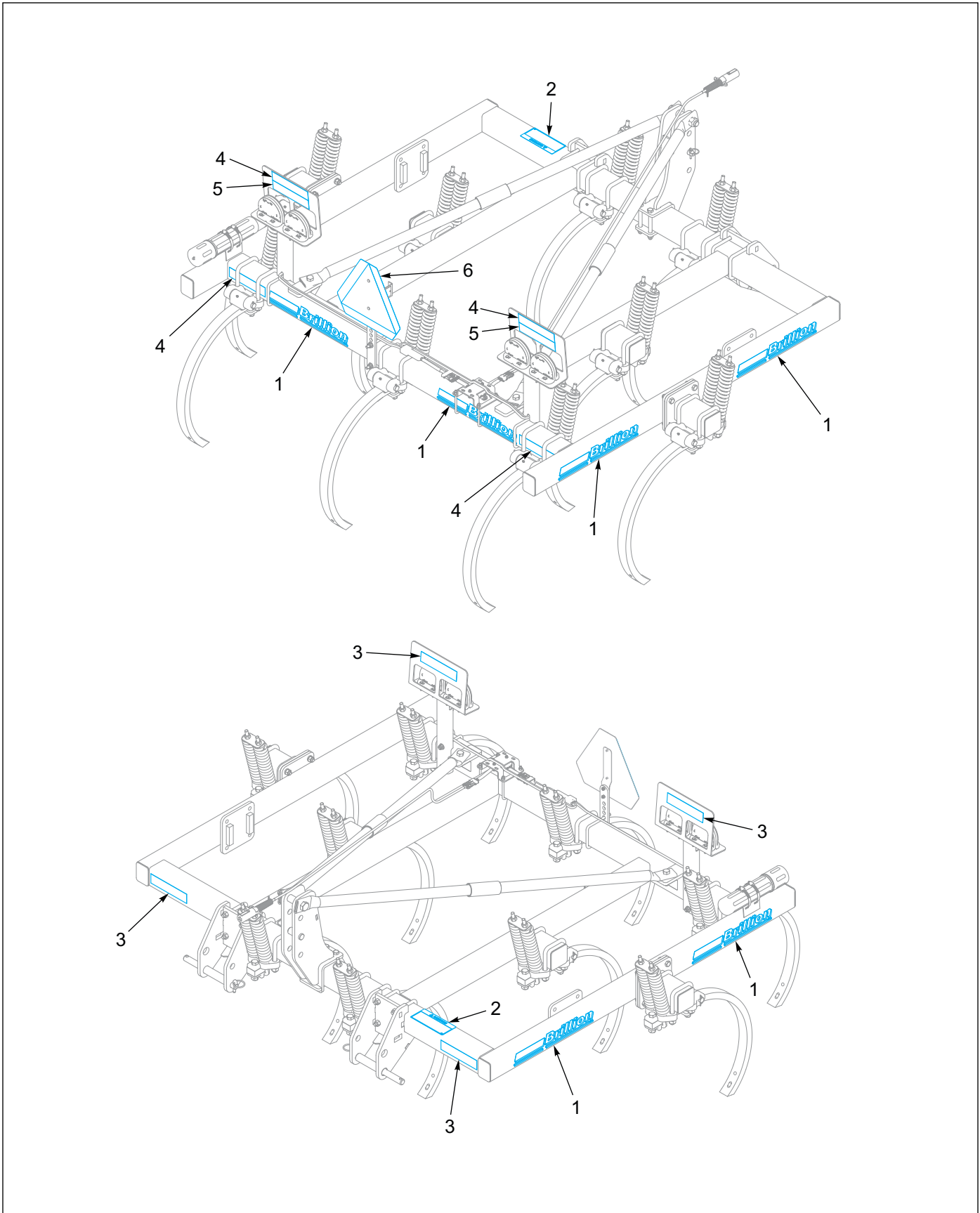

Figure 1-21: 7 and 9 Shank Model Decals

7 and 9 Shank Model Decals

ITEM	PART NUMBER	DESCRIPTION	QTY
1	4K036	DECAL-BRILLION (2 3/4 X 20)	6
2	8J310	DECAL - CAUTION	1
3	528934	REFLECTOR - YELLOW	4
4	528933	REFLECTOR - RED	4
5	528938	STRIPE, ORANGE	2
6	2P151	SMV W/BRACKET	1

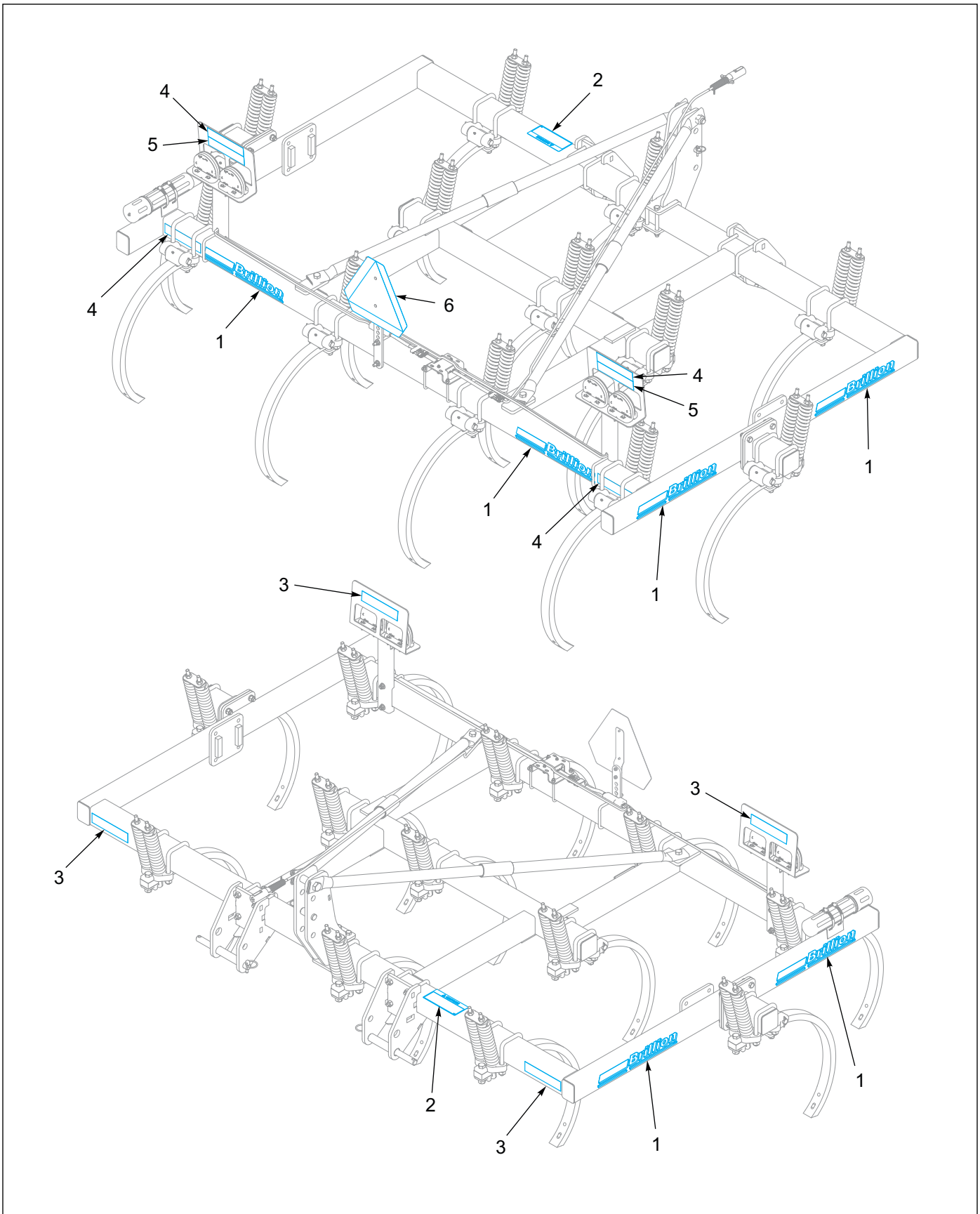

Figure 1-22: 10 and 12 Shank Model Decals

10 and 12 Shank Model Decals

ITEM	PART NUMBER	DESCRIPTION	QTY
1	4K036	DECAL-BRILLION (2 3/4 X 20)	6
2	8J310	DECAL - CAUTION	1
3	528934	REFLECTOR - YELLOW	4
4	528933	REFLECTOR - RED	4
5	528938	STRIPE, ORANGE	2
6	2P151	SMV W/BRACKET	1

ILLUSTRATED PARTS LIST

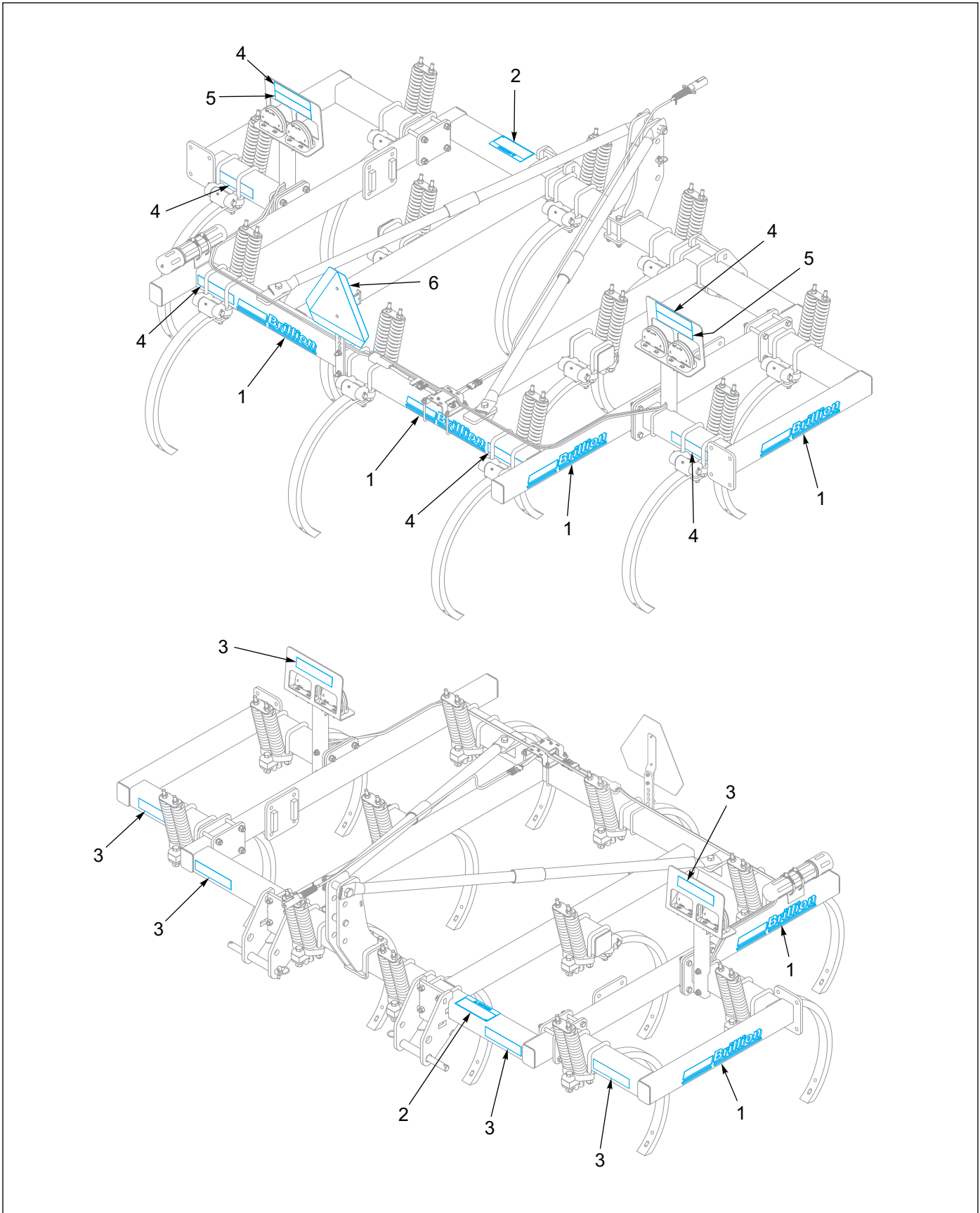

Figure 1-23: 11 Shank Model Decals

11 Shank Model Decals

ITEM	PART NUMBER	DESCRIPTION	QTY
1	4K036	DECAL-BRILLION (2 3/4 X 20)	6
2	8J310	DECAL - CAUTION	1
3	528934	REFLECTOR - YELLOW	6
4	528933	REFLECTOR - RED	6
5	528938	STRIPE, ORANGE	2
6	2P151	SMV W/BRACKET	1

Numerical Index

Numerics

1/2-13X3PLOW	1-13
104032	1-3, 1-5, 1-7
1-076-010008	1-27
108841	1-3, 1-5, 1-7, 1-22
110-0344	1-27
1-298-010001-1	1-11, 1-27
141776	1-11
1-512-010005-01	1-15, 1-17, 1-19
1-512-010005-05	1-25, 1-26
1-512-010005-13	1-3, 1-5, 1-7, 1-11, 1-22
1-512-010005-19	1-3, 1-5, 1-7
1-512-010007-11	1-3, 1-5, 1-7, 1-11, 1-20, 1-21, 1-23, 1-24
1-512-010007-12	1-3, 1-5, 1-7, 1-8, 1-11, 1-12
1-512-010007-13	1-12
1-557-010327	1-3, 1-5, 1-7
164678	1-3, 1-5, 1-7
1-647-010004217	1-11
1-654-010047-08	1-15, 1-17, 1-19
1-654-010049-05	1-3, 1-5, 1-7
1-654-010051-13	1-25, 1-26
1-654-010059-05	1-3, 1-5, 1-7, 1-20, 1-21
1-654-010059-09	1-23, 1-24
1-654-010059-15	1-7
1-654-010059-17	1-3, 1-5, 1-7
1-654-010059-21	1-12
1-654-010061-07	1-3, 1-5, 1-7
1-654-010061-20	1-12
1-654-10065-17	1-3, 1-5, 1-7
168344	1-25
168345	1-26
174435	1-15, 1-17, 1-19
174436	1-15, 1-17, 1-19
174437	1-15, 1-17, 1-19
178506	1-15, 1-17, 1-19
178507	1-15, 1-17, 1-19
178514	1-15, 1-17, 1-19
178525	1-15, 1-17, 1-19
178554	1-15, 1-17, 1-19
1-861-010032-09	1-3, 1-5, 1-7
1-861-010034-15	1-3, 1-5, 1-7, 1-11, 1-12, 1-20, 1-21, 1-23, 1-24
1-861-010034-17	1-3, 1-5, 1-7, 1-8, 1-11, 1-12
198938	1-3, 1-5, 1-7, 1-22
198939	1-3, 1-5, 1-7, 1-22
198944	1-3, 1-5, 1-7
198946	1-22
198947	1-22
198951	1-3, 1-5, 1-7
1D273	1-27
1J377	1-27
1J390	1-27
1J398	1-25, 1-26, 1-27
1J402	1-23, 1-25
1J404	1-24, 1-26
1J463	1-27
1J469	1-23, 1-24
2107649	1-27

NUMERICAL INDEX

2-557-010417	1-3, 1-5, 1-7, 1-22	6D362	1-11
2J091	1-11	6D409	1-11
2J092	1-11	6D529	1-3, 1-5, 1-7
2J094	1-11	6D913	1-8, 1-12
2J096	1-11	6D946	1-23
2J644	1-8, 1-12	6D988	1-3, 1-5, 1-7
2P151	1-3, 1-5, 1-7, 1-31, 1-33, 1-35	6J459	1-11
2P252	1-15, 1-17, 1-19	6K911	1-23, 1-24, 1-28
2P253	1-3, 1-5, 1-7, 1-15, 1-17, 1-19	712099	1-27
3/4-16HSN	1-27	7D017	1-3, 1-7
3J562	1-3, 1-5, 1-7, 1-15, 1-17, 1-19	7D441	1-24
415	1-28	7D442	1-5
4C129	1-28	7D472	1-3, 1-5, 1-7
4J293	1-8	7D473	1-3, 1-5, 1-7
4J675	1-11	7K964	1-13
4J681	1-8, 1-11	8J130	1-11
4K036	1-31, 1-33, 1-35	8J310	1-31, 1-33, 1-35
4K076	1-11	8J789	1-28
4K551	1-13	9D989	1-3, 1-5, 1-7, 1-22
4K552	1-13		
528933	1-31, 1-33, 1-35		
528934	1-31, 1-33, 1-35		
528938	1-31, 1-33, 1-35		
5C100	1-23, 1-24		
5C912	1-27		
5D157	1-3, 1-5, 1-7		
6D213	1-13		
6D215	1-13		
6D216	1-13		
6D226	1-20		
6D227	1-21		
6D234	1-12		
6D271	1-3, 1-5, 1-20, 1-21		
6D273	1-7		
6D280	1-11, 1-12		
6D283	1-8, 1-12		
6D298	1-12		
6D299	1-7		

Chapter 3

Glossary

For clarity this glossary of industry standard abbreviations and their definitions are provided.

For additional information, See "Instructions for Ordering Parts" on page 1-1.

A

ASM Assembly
AR As Required

B

BHSC Button Head Socket Cap
BLK Black
BLKHD Bulkhead
BTN Button

C

CB Carriage Bolt
CONN Connector
CP Cap
CRG Carriage
CVR Cover
CYL Cylinder

D

DBL Double
DEG Degree
DIA Diameter

E

ENCLSD Enclosed

F

FHCS Flanged Head Cap Screw
FHHCS Flanged Hex Head Cap Screw
FL OR FLG Flange
FLT Flat
FRT Front

G

GA Gauge
GR5 Grade 5
GR8 Grade 8

H

HHCS Hex Head Cap Screw
HLCL OR HEL Helical
HX Hex
HYD Hydraulic

I

ID Inside Diameter

L

LH Lefthand
LIM Limit
LKG OR LOCK Locking
LWR Lower

M

MANF Manifold
MNT Mount

GLOSSARY

N

NRW Narrow
NSS Not Serviced Separately
NYL Nylon

O

OD Outside Diameter
ORFS OR ORS O-Ring Seal
ORP OR ORB O-Ring Boss

R

RH Righthand
RND OR RD Round

S

SER Series
SGL Single
SHCS Socket Head Cap Screw
SLFLKG Selflocking
SPR Spring
SQ Square
SSCR Setscrew
SST Stainless Steel
STD Standard
SWVL Swivel

U

UNC Unified Coarse Thread
UNF Unified Fine Thread
UPR Upper

W

WHL Wheel
WLD OR WLDMT Weldment
WSHR Washer

Z

ZP Zinc Plate

Document Control Revision Log:

Date	Revision	Improvement(s) Description and Comments
07/2001		Initial Release
	175rev1113	Updated to the Landoll format. Added LED Warning Lights



Intertek

Equipment from Landoll Company, LLC is built to exacting standards ensured by ISO 9001 registration at all Landoll manufacturing facilities.

**Chisel Plow
Models: CPP7 through CPP12
Parts Manual**

Re-Order Part Number 7D524

LANDOLL COMPANY, LLC

1900 North Street

Marysville, Kansas 66508

(785) 562-5381

800-428-5655 ~ WWW.LANDOLL.COM



Copyright 2020. Landoll Company, LLC

"All rights reserved, including the right to reproduce this material or portions thereof in any form."