

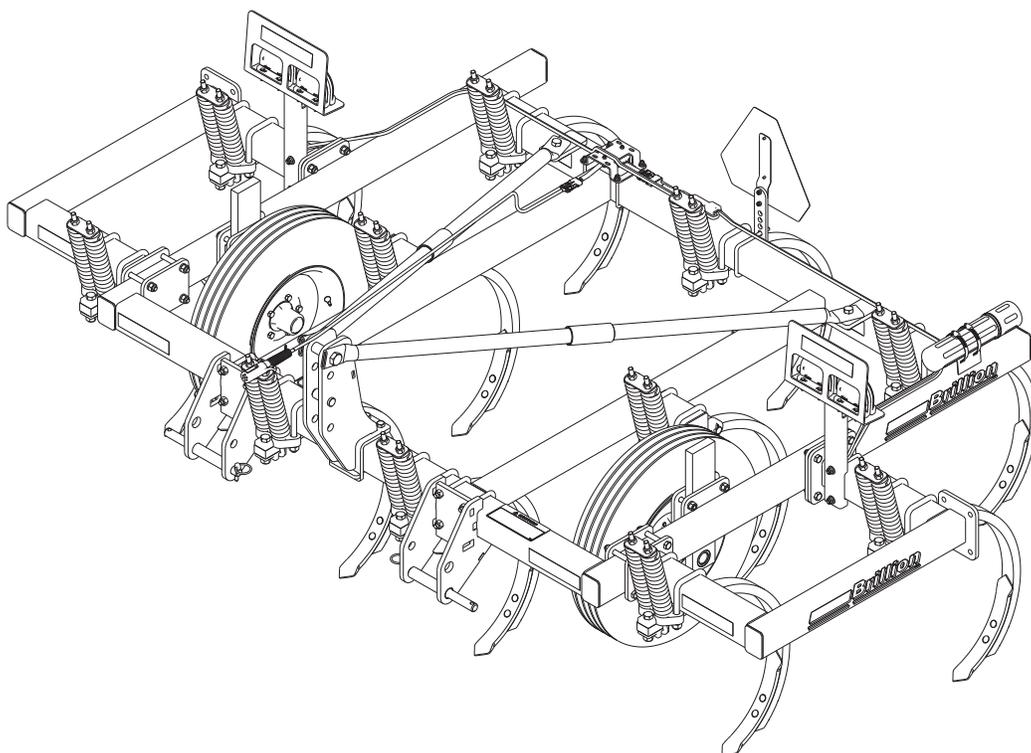

# Chisel Plow, 3-Bar Mounted Models: CPP7 thru CPP12 Operator's Manual



**LANDOLL COMPANY, LLC**

1900 North Street

Marysville, Kansas 66508

(785) 562-5381

800-428-5655 ~ [WWW.LANDOLL.COM](http://WWW.LANDOLL.COM)

## Manuals for 3-Bar Mounted, Chisel Plow

Manual Number	Manual Type
7D525	Operator's Manual
7D524	Parts Manual



## **DANGER**

**DO NOT operate or perform any maintenance tasks on this equipment until you have completed the following:**

- 1. Receive proper training to operate this equipment safely.**
- 2. Read and understand the operator's manual.**
- 3. Be thoroughly trained on inspection and repair procedures.**

**Failure to comply with this warning may result in serious injury or possibly death.**



# Table of Contents

---

## 1 Introduction and Safety

Introduction . . . . .	1-1
Description of Unit . . . . .	1-1
Using this Manual . . . . .	1-1
Owner Assistance . . . . .	1-1
Safety . . . . .	1-2
Understanding Safety Statements . . . . .	1-2
Transporting Safety . . . . .	1-2
Attaching, Detaching and Storage . . . . .	1-3
Maintenance Safety . . . . .	1-3
Protective Equipment . . . . .	1-3
Tire Safety . . . . .	1-3
Decals . . . . .	1-4
Decal Locations . . . . .	1-5

## 2 Assembly

Main Frame Assembly . . . . .	2-1
Manual Storage Canister . . . . .	2-1
SMV Sign . . . . .	2-1
Frame Assembly Dimensions . . . . .	2-3
Frame Extensions, 1FT . . . . .	2-6
Frame Extensions, 2FT . . . . .	2-7
Shank Installation . . . . .	2-8
Spring Clamp Shank Assembly . . . . .	2-13
Rigid Clamp Shank Assembly . . . . .	2-13
Point Installation . . . . .	2-14
Chisel Plow Point . . . . .	2-14
Twisted Shovels . . . . .	2-14
Gauge Wheels Kits - Optional . . . . .	2-15
LED Warning Lights Installation . . . . .	2-16

## 3 Operation

General . . . . .	3-1
Operating Tips . . . . .	3-1
Operating Speed . . . . .	3-1
Tractor Preparation . . . . .	3-1
Attaching to 3-PT Hitch . . . . .	3-2
Field Operation . . . . .	3-2
Spring Shank Tension Adjustment . . . . .	3-2
Transport . . . . .	3-3

**4 Maintenance**

General Torque Specifications . . . . . 4-1  
Fasteners . . . . . 4-2  
Tires . . . . . 4-2  
Points . . . . . 4-2  
Lubrication Maintenance . . . . . 4-2  
Warning Lamps . . . . . 4-3  
Storage . . . . . 4-3

**5 Specifications**

# Introduction and Safety

## Introduction

The implement described in this manual has been designed with care and built by skilled workers using quality materials and processes. Proper assembly and maintenance will provide you with satisfactory use for seasons to come.

**Read this entire manual before attempting to assemble, adjust or operate this implement. Failure to comply with this warning can result in personal injury or death, damage to the implement or its components and inferior operation.**

## Description of Unit

The Chisel Plow was the machine that started the age of “conservation tillage” as we know it today. The 3-Bar Chisel Plows offer an effective and economic solution to basic primary tillage. A wide variety of shank configurations and points allow the producer to fine tune the Chisel Plow to fit his requirements. Optional extension kits allow the 3 Bar Chisel Plow to grow with any operation.

## Using this Manual

This manual will familiarize you with safety, assembly, operation, adjustment, and maintenance. Read this manual and follow the recommendations to help ensure safe and efficient operation.

- The information in this manual is current at time of printing. Some parts may have changed to assure top performance.
- Location reference: Right and Left designations in this manual are determined by facing the direction the implement will travel during field operation, unless otherwise stated.

## Owner Assistance

If customer service or repairs are needed, contact your Brillion dealer. They have trained personnel, parts and service equipment specially designed for Brillion products. Your implement’s parts should only be replaced with Brillion parts. If items covered in this manual are not understood, contact your local Brillion Dealer.

## Warranty Registration

Brillion Farm Equipment, by Landoll, shall have no warranty obligation unless each product is registered within 10 days of retail purchase, using the Landoll Company, LLC Ag Products on-line registration process. Please refer to the Ag Products Policy and Procedures Manual, accessible at [www.landoll.com](http://www.landoll.com) for step by step instructions regarding product registration.

Enter your product information below for quick reference. Refer to the ID plate as shown. **See Figure 1-1.**

MODEL NUMBER \_\_\_\_\_

SERIAL NUMBER \_\_\_\_\_

DATE OF PURCHASE \_\_\_\_\_

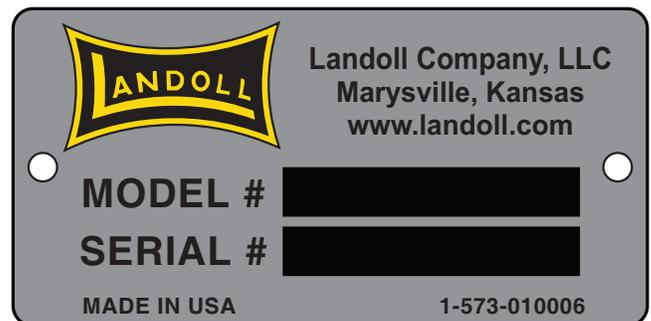

Figure 1-1: ID Plate

# Safety

**NOTE**

*Investigation has shown that nearly 1/3 of all farm accidents are caused by careless use of machinery. Insist that all people working with you or for you abide by all safety instructions.*

## Understanding Safety Statements

You will find various types of safety information on the following pages and on the implement decals (signs) attached to the implement. This section explains their meaning.

**Special notice - read and thoroughly understand.**

**Proceed with caution. Failure to heed caution may cause injury to person or damage product.**

**Proceed with caution. Failure to heed warning will cause injury to person or damage product.**

**Proceed with extreme caution. Failure to heed notice will cause injury or death to person and/or damage product.**

**NOTE**

*You should read and understand the information contained in this manual and on the implement decals before you attempt to operate or maintain this equipment.*

- Examine safety decals and be sure you have the correct safety decals for the implement. **See Figure 1-2.**
- Order replacement decals through your Brillion dealer.
- Keep these signs clean so they can be observed readily. It is important to keep these decals cleaned more frequently than the implement. Wash with soap and water or a cleaning solution as required.

- Replace decals that become damaged or lost. Also, be sure that any new implement components installed during repair include decals which are assigned to them by the manufacturer.
- When applying decals to the implement, be sure to clean the surface to remove any dirt or residue. Where possible, sign placement should protect the sign from abrasion, damage, or obstruction from mud, dirt, oil etc.

**Do not allow anyone to ride on the tractor or implement. Riders could be struck by foreign objects or thrown from the implement.**

**Never allow children to operate equipment.**

**Keep bystanders away from implement during operation.**

## Transporting Safety

**IMPORTANT**

**It is the responsibility of the owner/operator to comply with all state and local laws.**

When transporting the implement on a road or highway, use adequate warning symbols, reflectors, lights and slow moving vehicle sign as required. Slow moving tractors and towed implements can create a hazard when driven on public roads. They are difficult to see, especially at night.

Do not tow an implement that, when fully loaded, weighs more than 1.5 times the weight of the towing vehicle.

Carry reflectors or flags to mark the tractor and implement in case of breakdown on the road.

Do not transport at speeds over 20 MPH under good conditions. Never travel at a speed which does not allow adequate control of steering and stopping. Reduce speed if towed load is not equipped with brakes.

Avoid sudden stops or turns because the weight of the implement may cause the operator to lose control of the tractor. Use a tractor heavier than the implement.

Use caution when towing behind articulated steering tractors; fast or sharp turns may cause the implement to shift sideways.

Keep clear of overhead power lines and other obstructions when transporting. Know the transport height and width of your implement.



## **Attaching, Detaching and Storage**

- Do not stand between the tractor and implement when attaching or detaching implement unless both are blocked from moving.

## **Maintenance Safety**

- Do not make adjustments or lubricate the machine while it is in motion.
- Make sure all moving parts have stopped.
- Understand the procedure before doing the work. Use proper tools and equipment.

## **Protective Equipment**

- Wear protective clothing & equipment appropriate for the job. Avoid loose fitting clothing.
- Because prolonged exposure to loud noise can cause hearing impairment or hearing loss, wear suitable hearing protection, such as earmuffs or ear-plugs.

## **Tire Safety**

Tire changing can be dangerous and should be performed by trained personnel using correct tools and equipment.

When inflating tires, use a clip-on chuck and extension hose long enough to allow you to stand to one side, not in front of or over the tire assembly. Use a safety cage if available.

When removing and installing wheels use wheel-handling equipment adequate for the weight involved.

**Decals**



ITEM 1 - 4K036



ITEM 2 - 8J310



ITEM 3  
528934



ITEM 4  
528933



ITEM 5  
528938

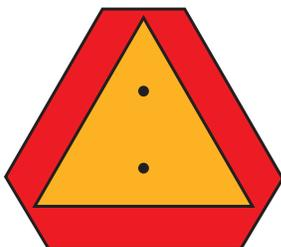

ITEM 6 - 2P151



ITEM 7  
1-573-010006 - "PLACARD"



ITEM 9  
2-573-010198

**Figure 1-2: Decals**

# Decal Locations

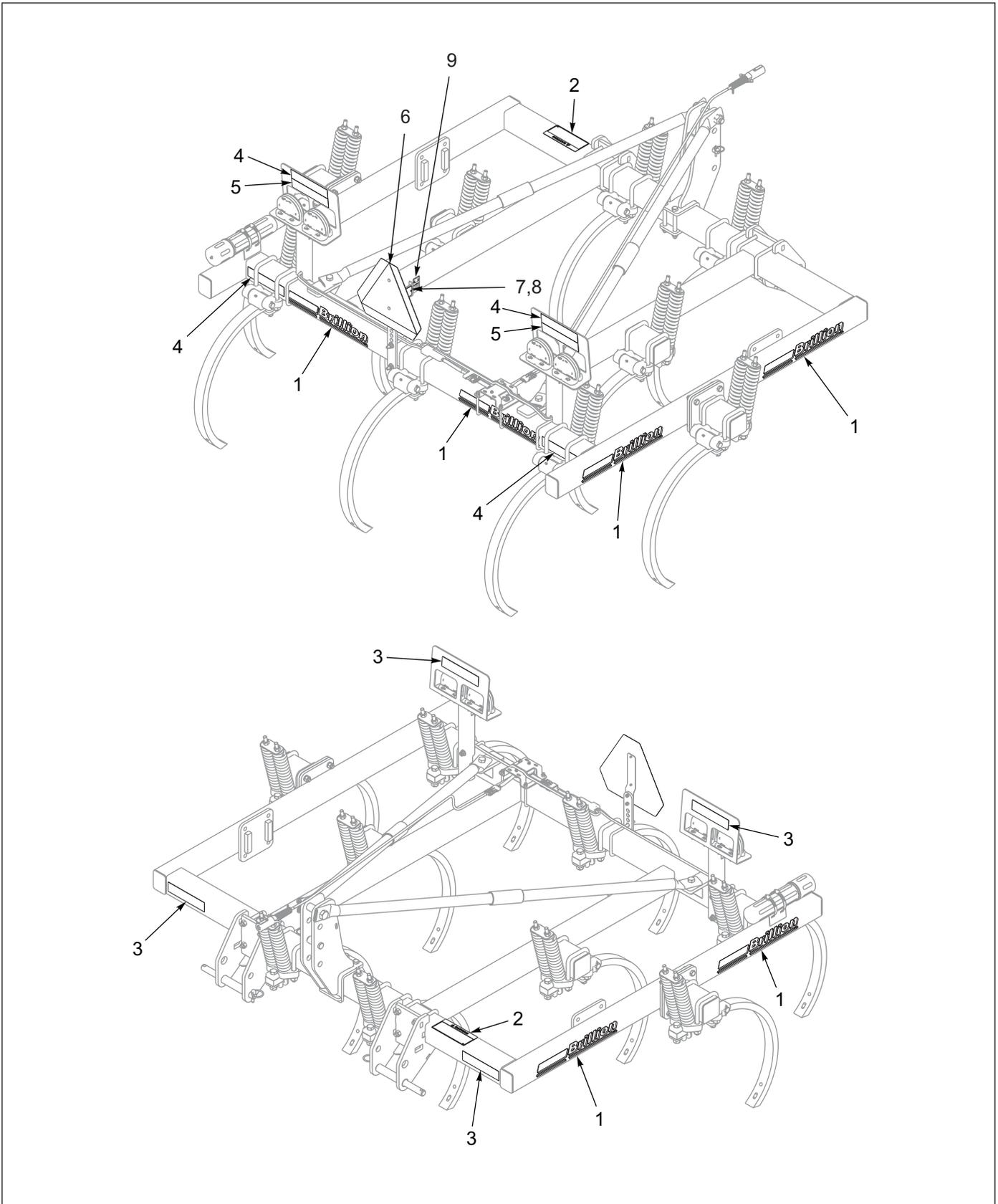

Figure 1-3: Decal Locations (7 and 9 Shank Models)

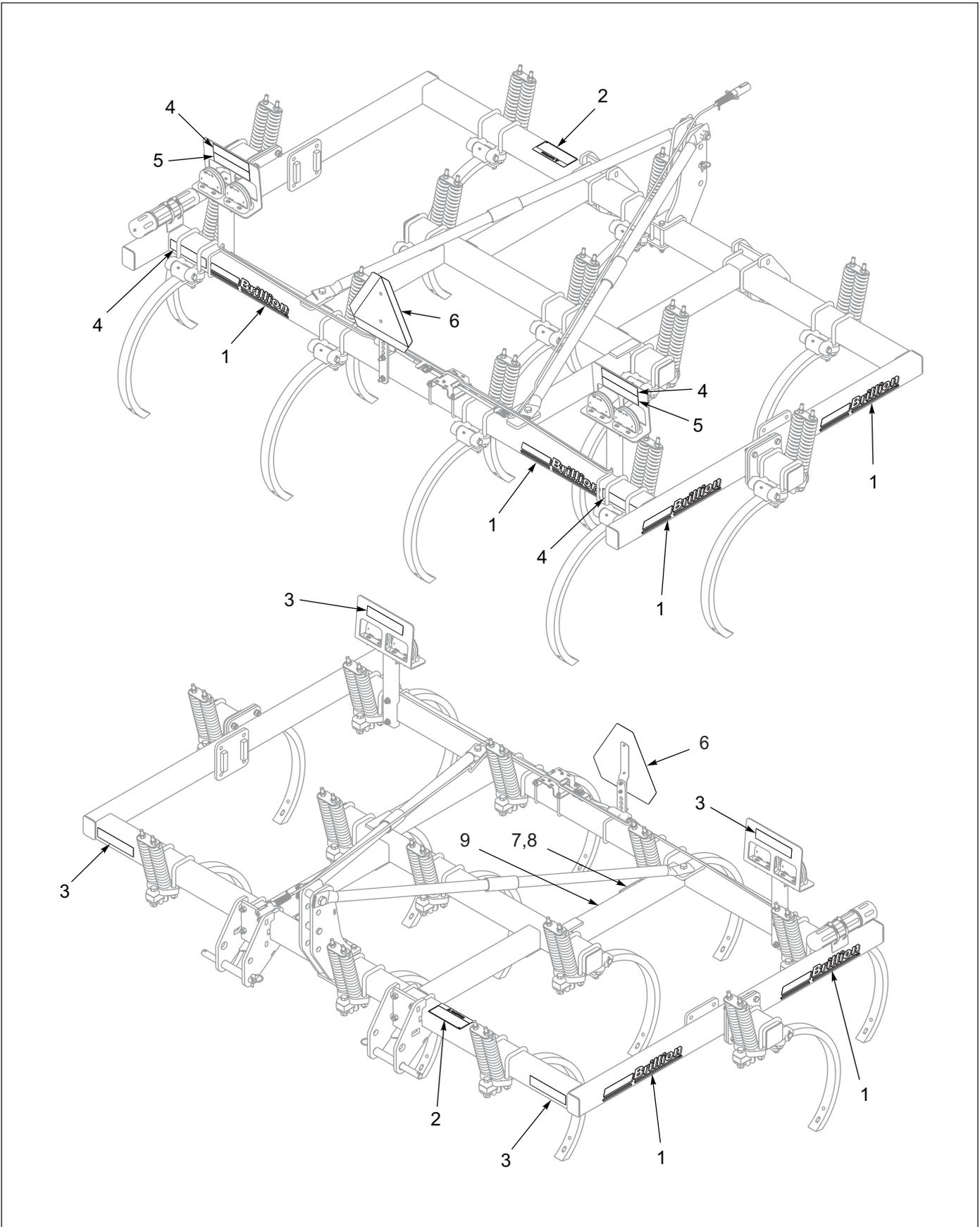

Figure 1-4: Decal Locations (10 and 12 Shank Models)

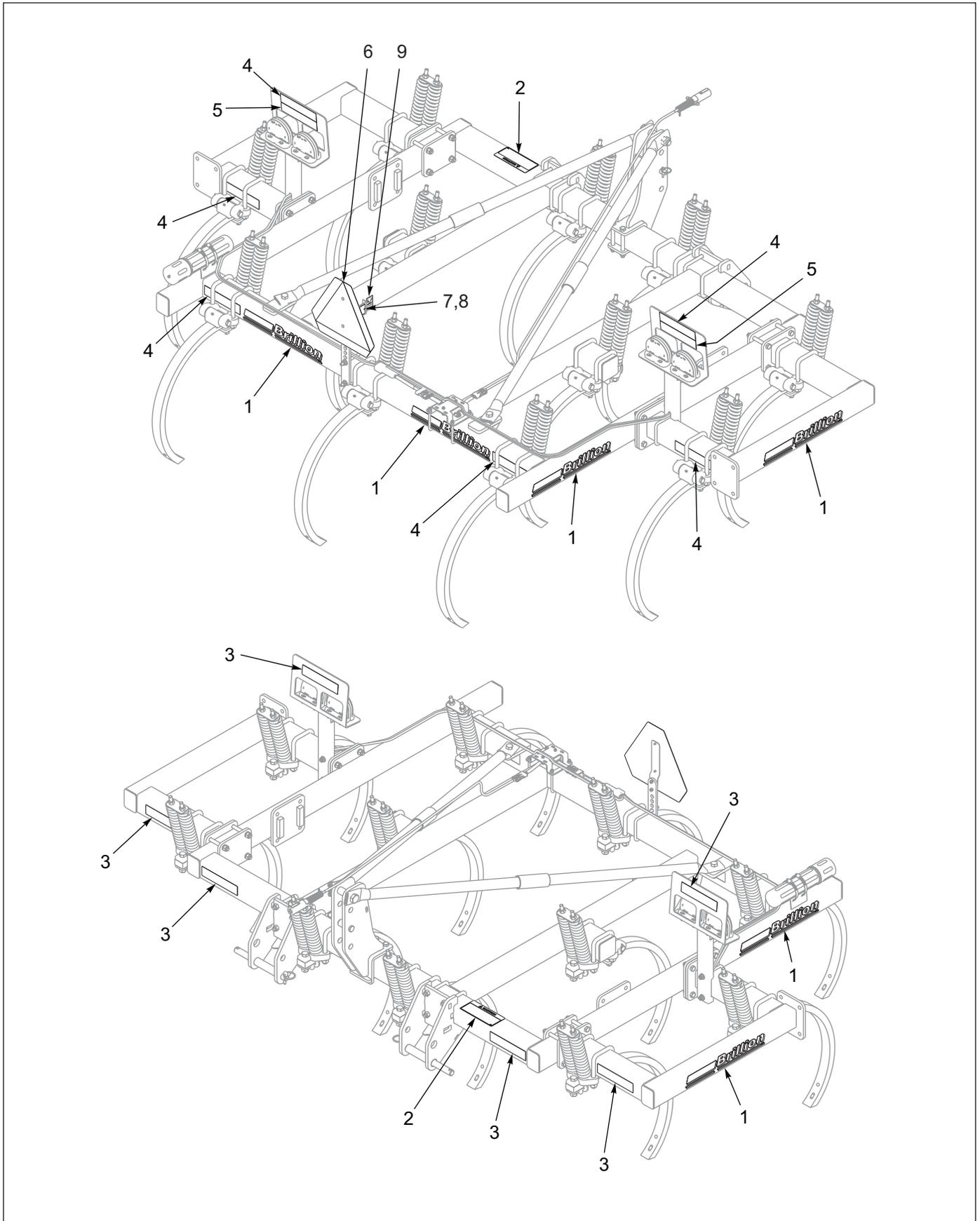

Figure 1-5: Decal Locations (11 Shank Models)



# Assembly

**Do not work on or under this machine unless securely blocked and supported by a hoist or tractor or by other sufficient means.**

**Do not attempt to lift heavy parts (such as the frame, rock shaft, and pull hitch) manually. Use a hoist or a fork lift to move these parts into position.**

## NOTE

Refer to the repair parts manual 7D524 for identification of parts and for the approximate relationship of the parts in assembly.

To ensure alignment of assemblies, **leave the nuts loose until completion** of final assembly. Use lock washers or flat washers as specified. Spread all cotter pins.

**After completion of final assembly, tighten all nuts evenly** to prevent misalignment, distortion or binding.

Tighten all screws and nuts to the recommended torques.

Using blocks or other supports, block up the Frame approximately 36". Be sure that it is secure and cannot topple.

## IMPORTANT

- If pre-assembled parts or fasteners are temporarily removed, remember where they go. It is best to keep parts separated.
- Check that all working parts move freely, bolts are tight and cotter pins spread.
- Refer to the Torque Table for proper torque values. Note the different torque requirements for bolts with locknuts. **See "General Torque Specifications" on page 4-1.**

*"Left" and "Right" refer to directions seen as if standing behind the machine and facing in the direction of forward travel.*

## Main Frame Assembly

1. Place the frame on blocks at least 36-42 inches high for the assembly of the machine.
2. **See Figure 2-2** for the dimensional location of the Upper and Lower Hitch Brackets.
3. Assemble Upper Hitch Bracket to the center of the Front Frame Tube. Slide Upper Hitch Bracket Plate in the slot of the Upper Hitch Bracket and under the Front Frame Tube. Secure with 5/8-11 x 6 Bolts and Locknuts. **See Figure 2-1.**
4. Place 1-5/16 x 2-1/8 spacer between the top holes of the Upper Hitch Bracket and place the LH and RH Braces on either side of the Bracket. Insert 1-8 x 6 Bolt and secure with Locknut. Install braces to the rear of the Frame with 3/4-10 x 2-1/2 Bolt, Lock Washer and Nut.
5. Assemble LH and RH Lower Hitch Brackets to the Front Frame Tube. Secure with 5/8-11 U-Bolts and Locknuts.
6. Determine the category of tractor and Length of Shank that will be used and install the Upper and Lower Hitch pins into the Hitch Brackets. **See Figures 2-1, 2-3 and 2-3.**

Tighten all hardware to the recommended torques. **See "General Torque Specifications" on page 4-1.**

## Manual Storage Canister

Install the Manual Storage canister to the frame with Hose Clamps. **See Figure 2-1.**

## SMV Sign

Attach the SMV Mount about 4 inches left of center on the rear Frame Tube with 1/2-13 U-Bolt and Flange Locknuts. **See Figure 2-1.** Install SMV Sign to Mount with 5/16-18 x 1 Bolts, Flat Washers and Locknuts.

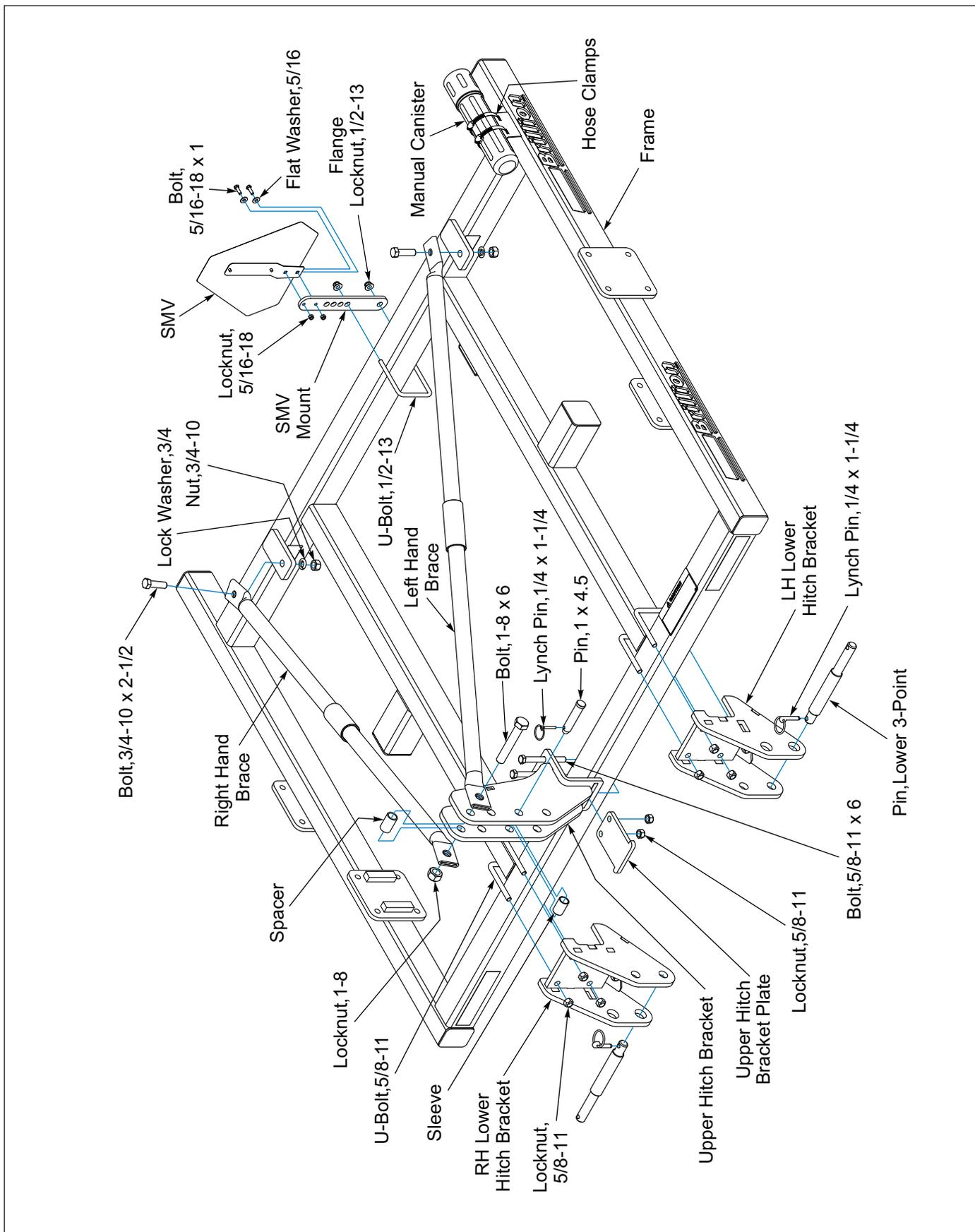

Figure 2-1: Frame



# Frame Assembly Dimensions

"Left" and "Right" refer to directions seen as if standing behind the machine and facing in the direction of forward travel.

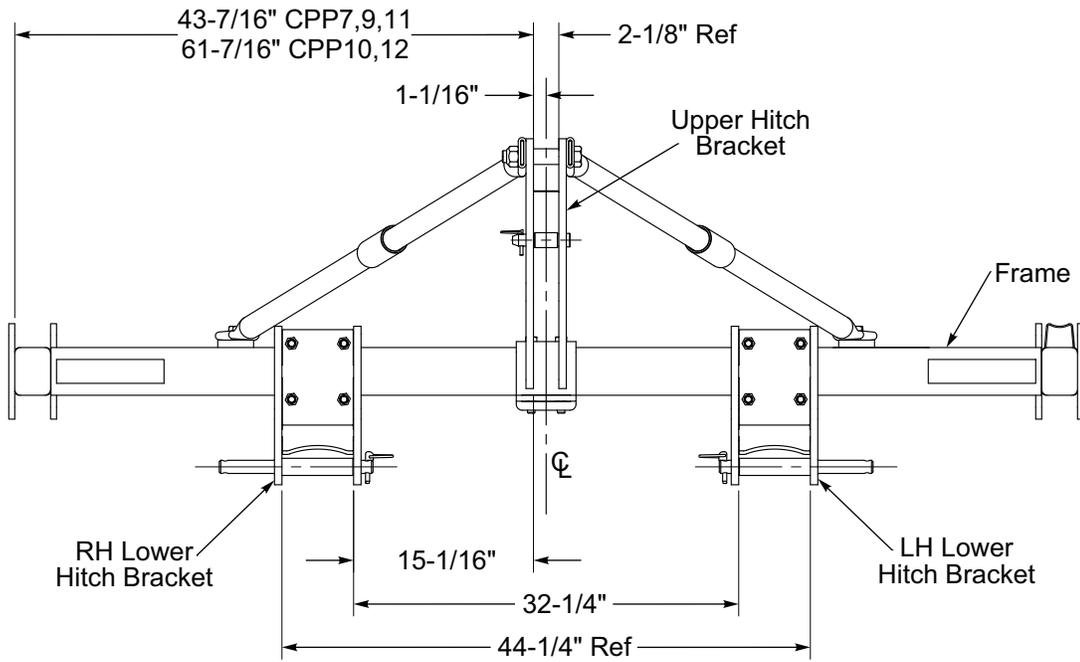
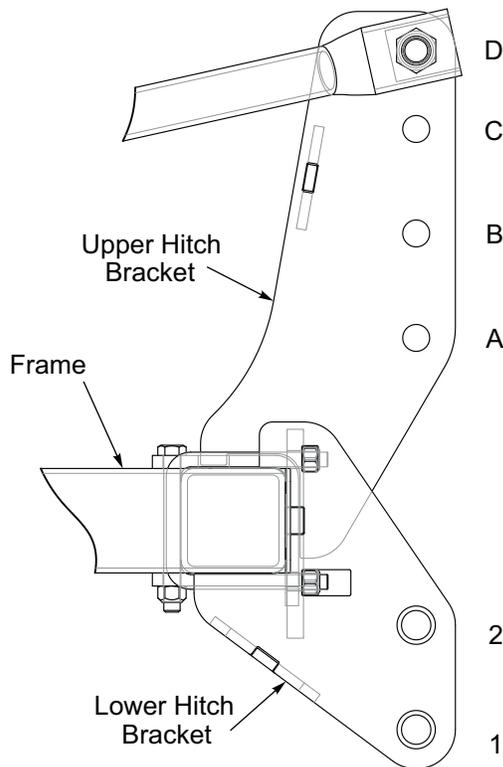

Figure 2-2: Frame Assembly Dimensions

Tractor Category Shank Length	Upper Hitch Pin Position	Lower Hitch Pin Position	Lower Hitch Pin Orient
CAT 2 Free Link 26" Shank	C	1	View AA
CAT 2 Free Link 32" Shank	B	1	View AA
CAT 2 Quick Coupler 26" Shank	B	2	View BB
CAT 2 Quick Coupler 32" Shank	A	1	View CC
CAT 3 Free Link 26" Shank	D	1	View CC
CAT 3 Free Link 32" Shank	C	1	View CC
CAT 3 Quick Coupler CAT 3N Quick Coupler 26" Shank	C	2	View BB
CAT 3 Quick Coupler CAT 3N Quick Coupler 32" Shank	B	1	View CC



**Figure 2-3: Upper and Lower Hitch Pin Positions**

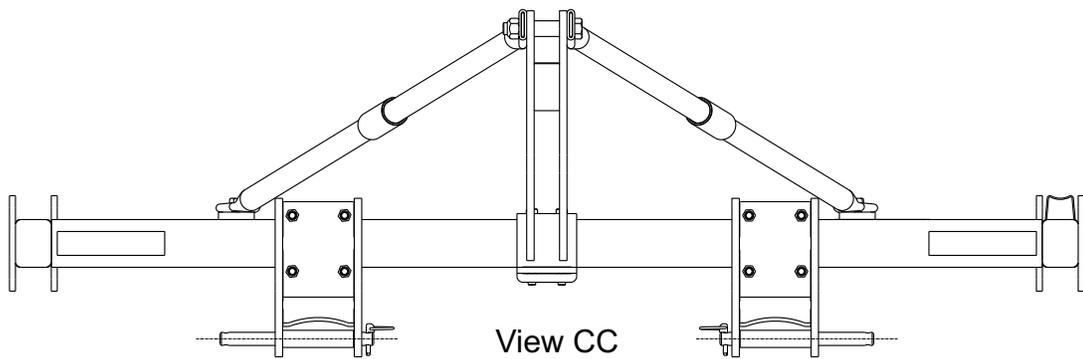
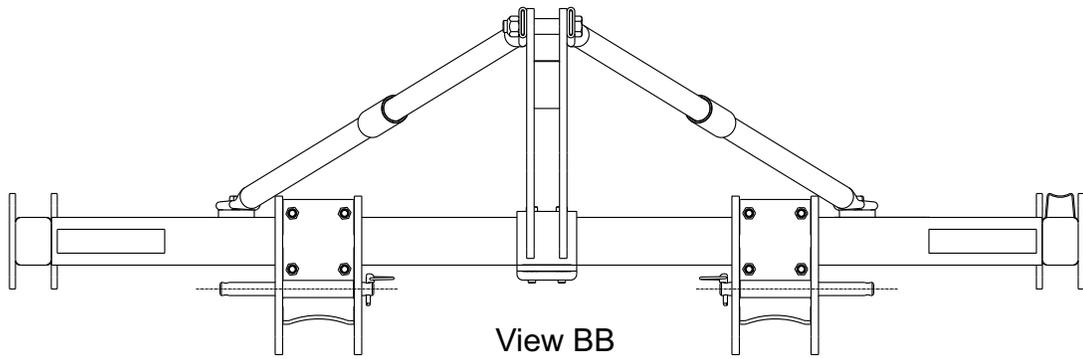
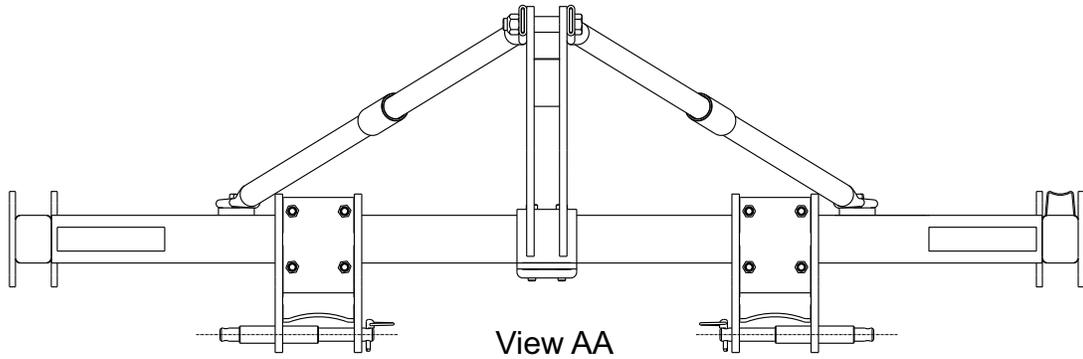

Figure 2-4: Lower Hitch Orientation

# Frame Extensions, 1FT

Install a 1 FT Frame Extensions on each 4-Hole Plate on the outer tubes of the Frame with 5/8-11 X 2 Bolts, Lock Washers and Nuts.

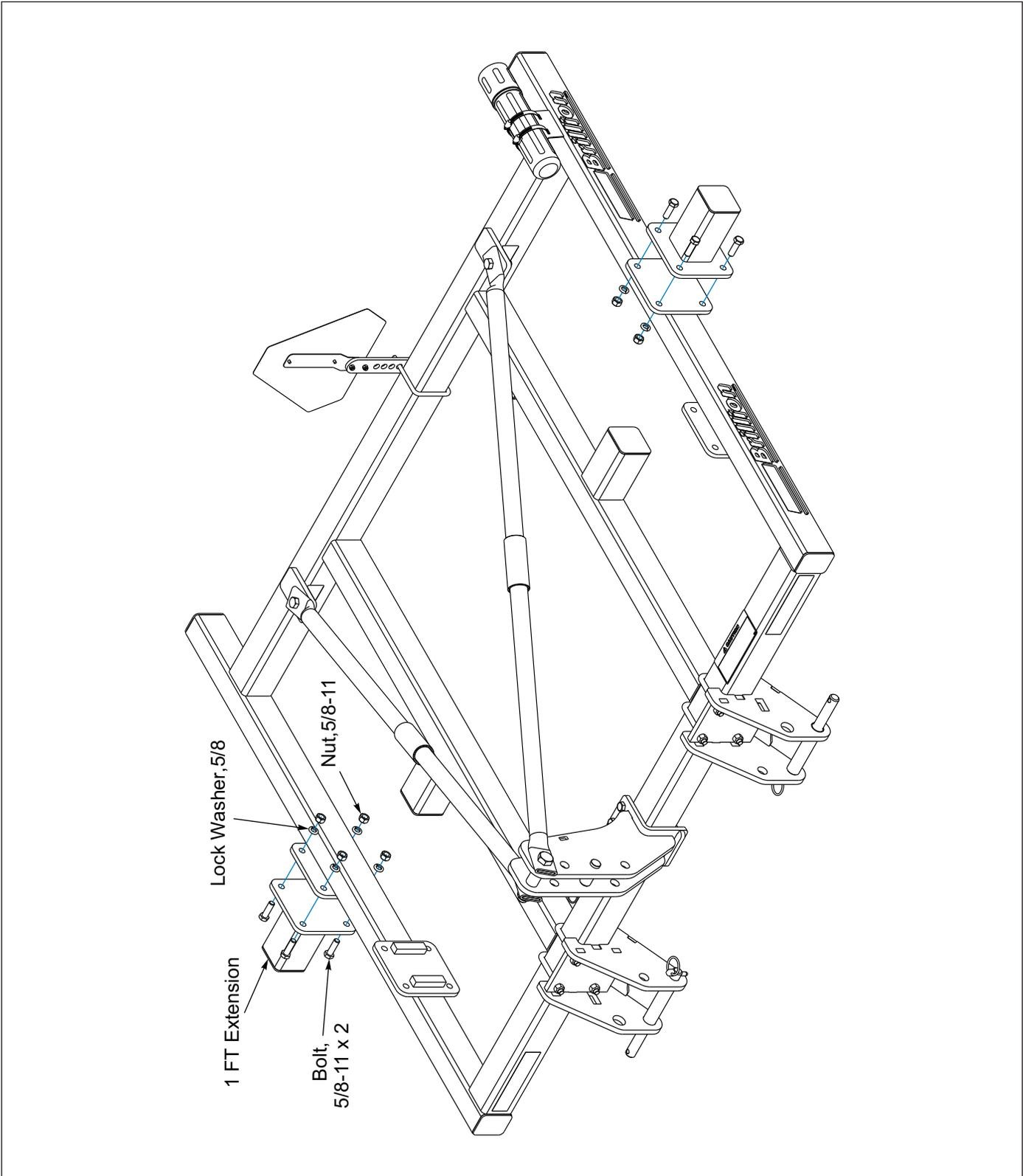
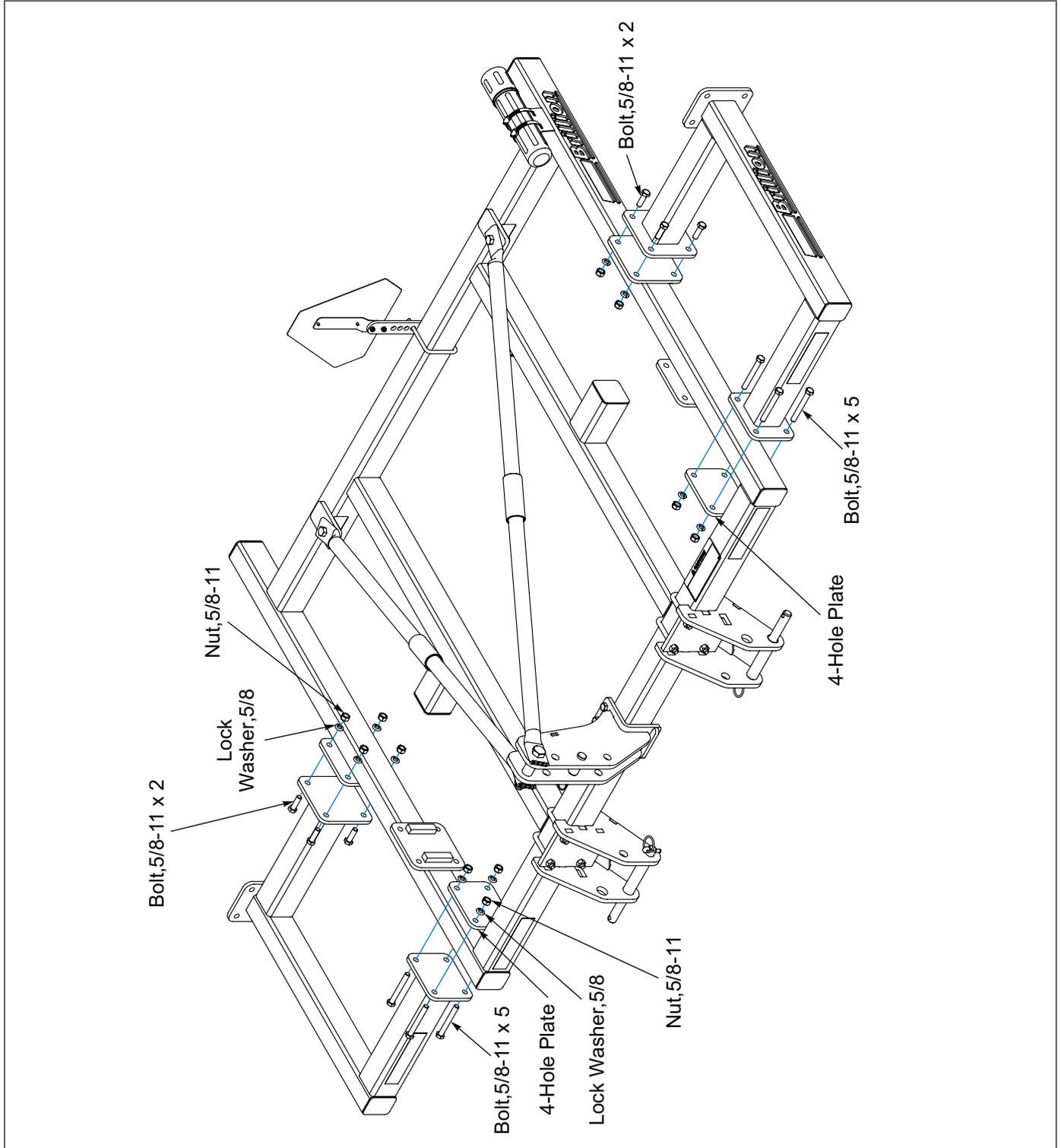

Figure 2-5: 1FT Frame Extensions

# Frame Extensions, 2FT

Install a 2 FT Frame Extensions on each 4-Hole Plate on the outer tubes of the Frame with 5/8-11 x 2 Bolts, Lock Washers and Nuts. Secure the front of the Extension by placing a 4-Hole Plate on the inside of the Frame Tube. Secure with 5/8-11 x 5 Bolts, Lock Washers and Nuts.

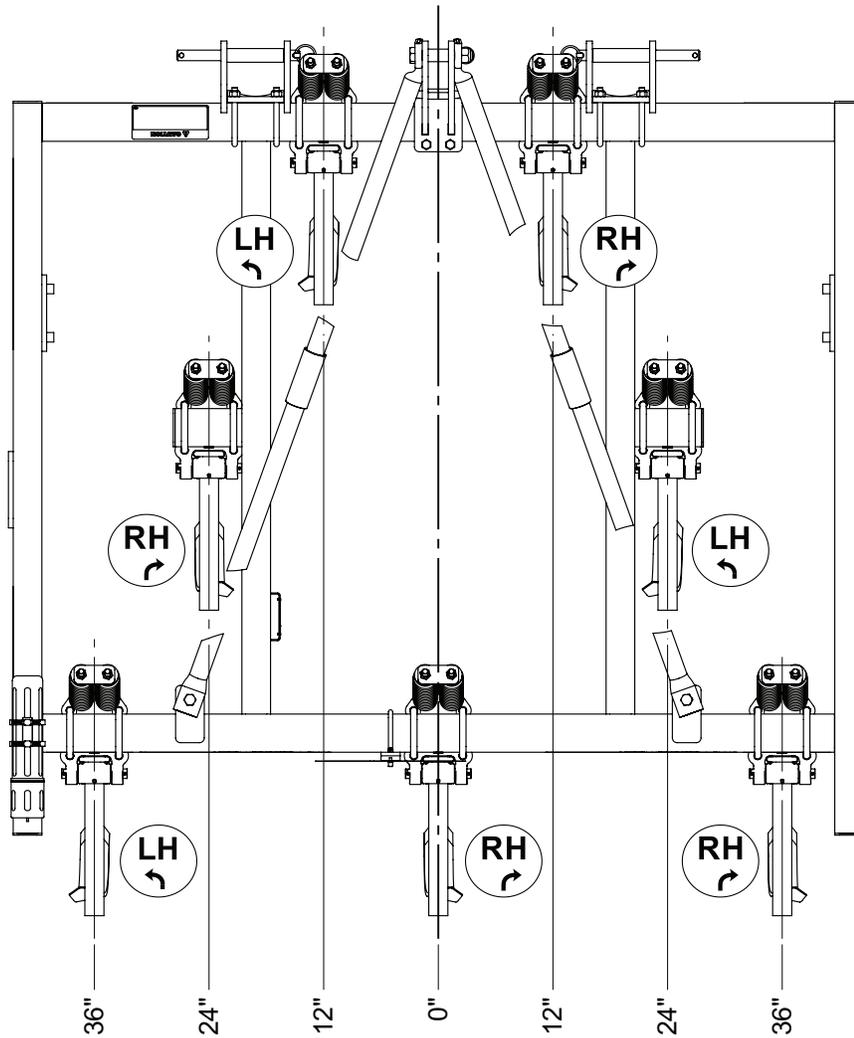

**Figure 2-6: 2FT Frame Extensions**

# Shank Installation

Attach the Shank Assemblies to the frame in the locations indicated in **Figures 2-7 through 2-12**.

Shank Assemblies are shipped with all the necessary hardware to mount the shanks to the frame.



CPP 7 Shank

*L.H. and R.H. refer to  
Left and Right Hand  
Twisted Shovel Installation.*

**Figure 2-7: CPP7 Shank and Shovel Locations**

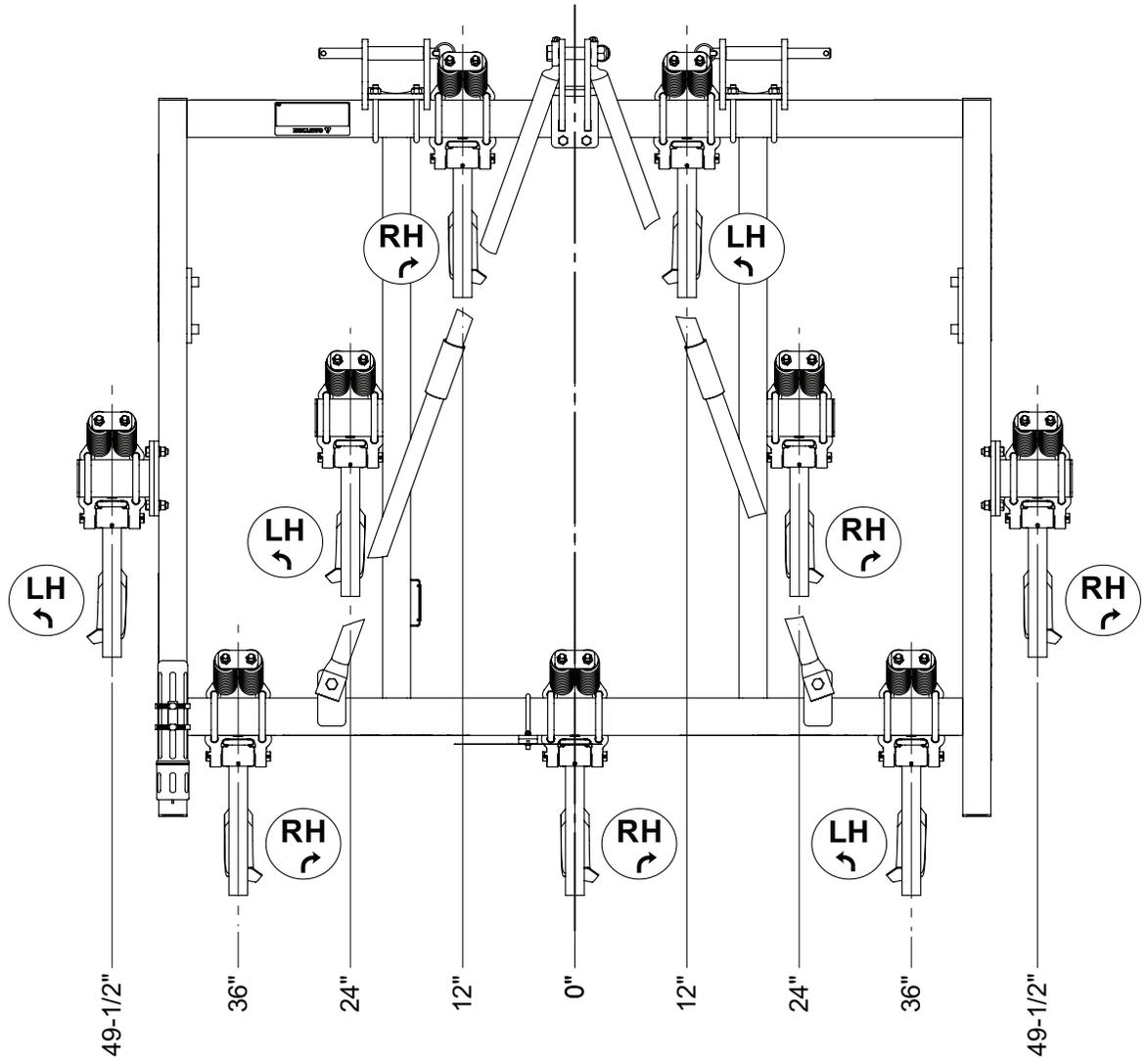

CPP 9 Shank

*L.H. and R.H. refer to  
Left and Right Hand  
Twisted Shovel Installation.*

Figure 2-8: CPP9 Shank and Shovel Locations

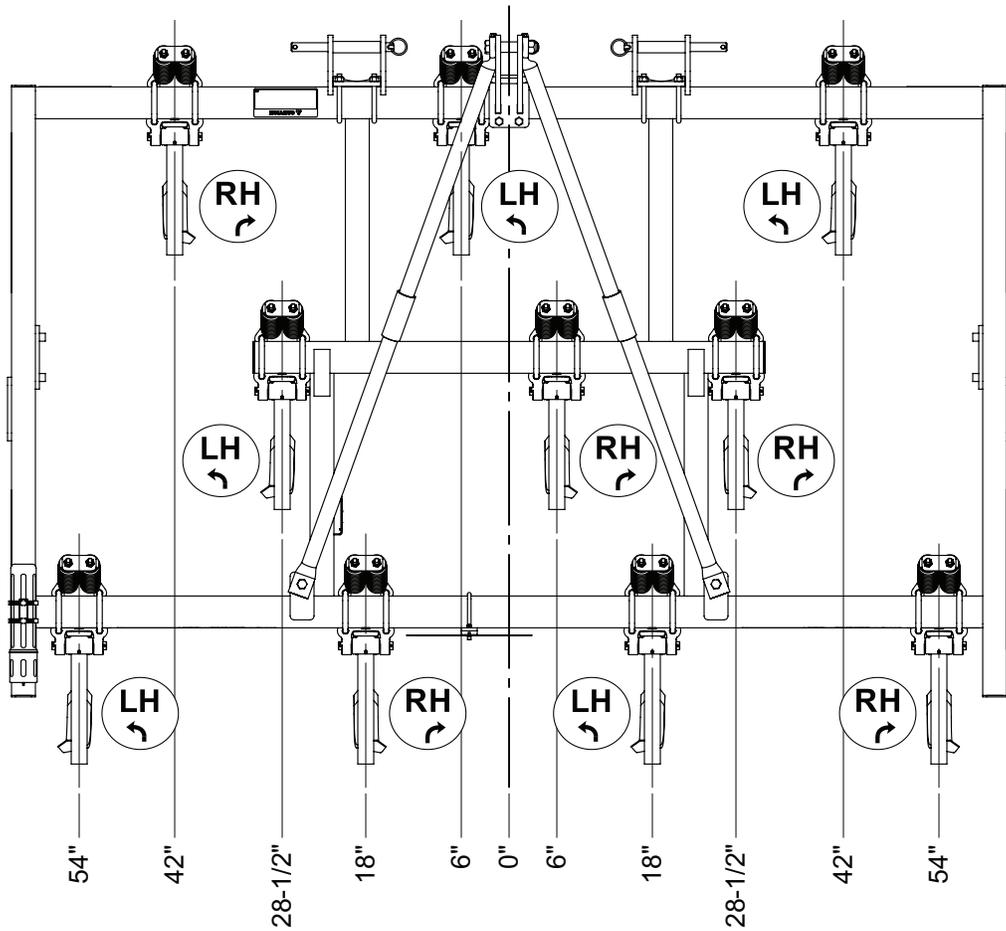

CPP 10 Shank

*L.H. and R.H. refer to  
Left and Right Hand  
Twisted Shovel Installation.*

Figure 2-9: CPP10 Shank and Shovel Locations



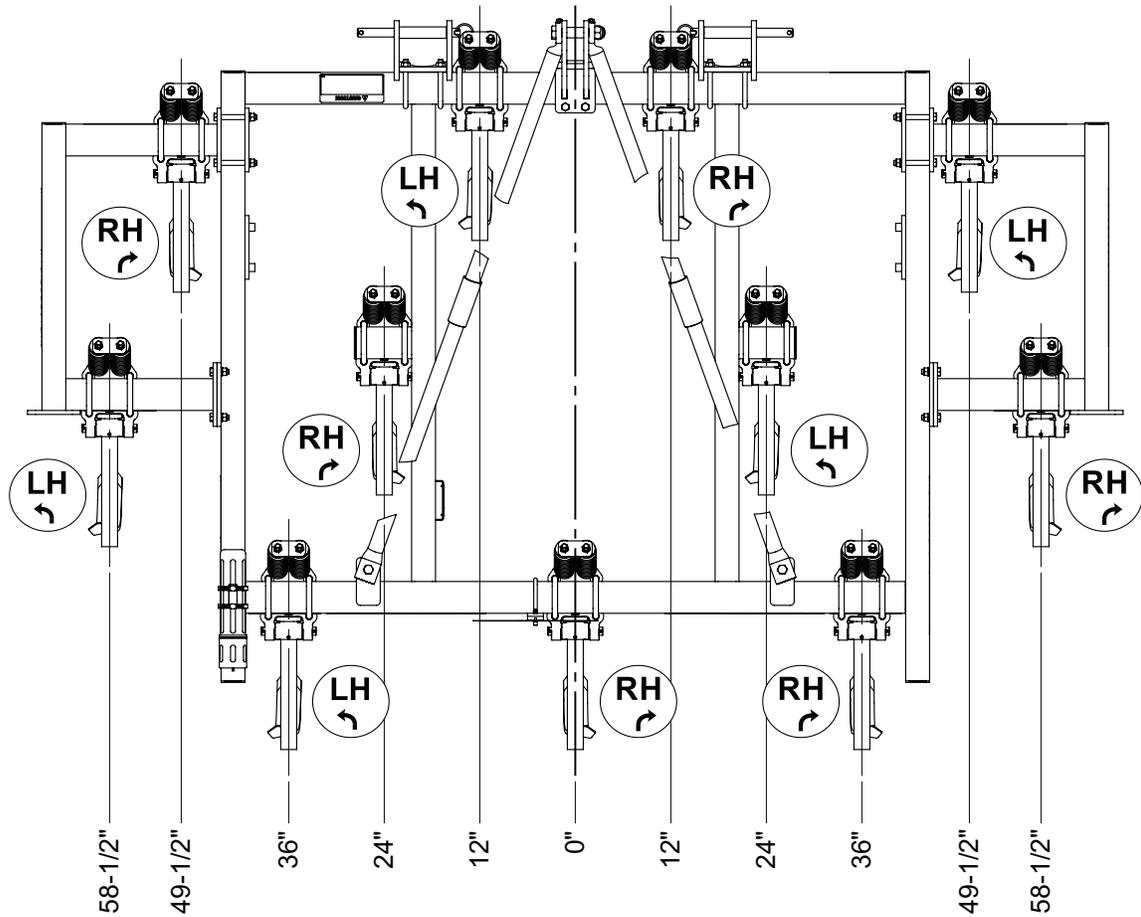

CPP 11 Shank

*L.H. and R.H. refer to  
Left and Right Hand  
Twisted Shovel Installation.*

Figure 2-10: CPP11 Shank and Shovel Locations

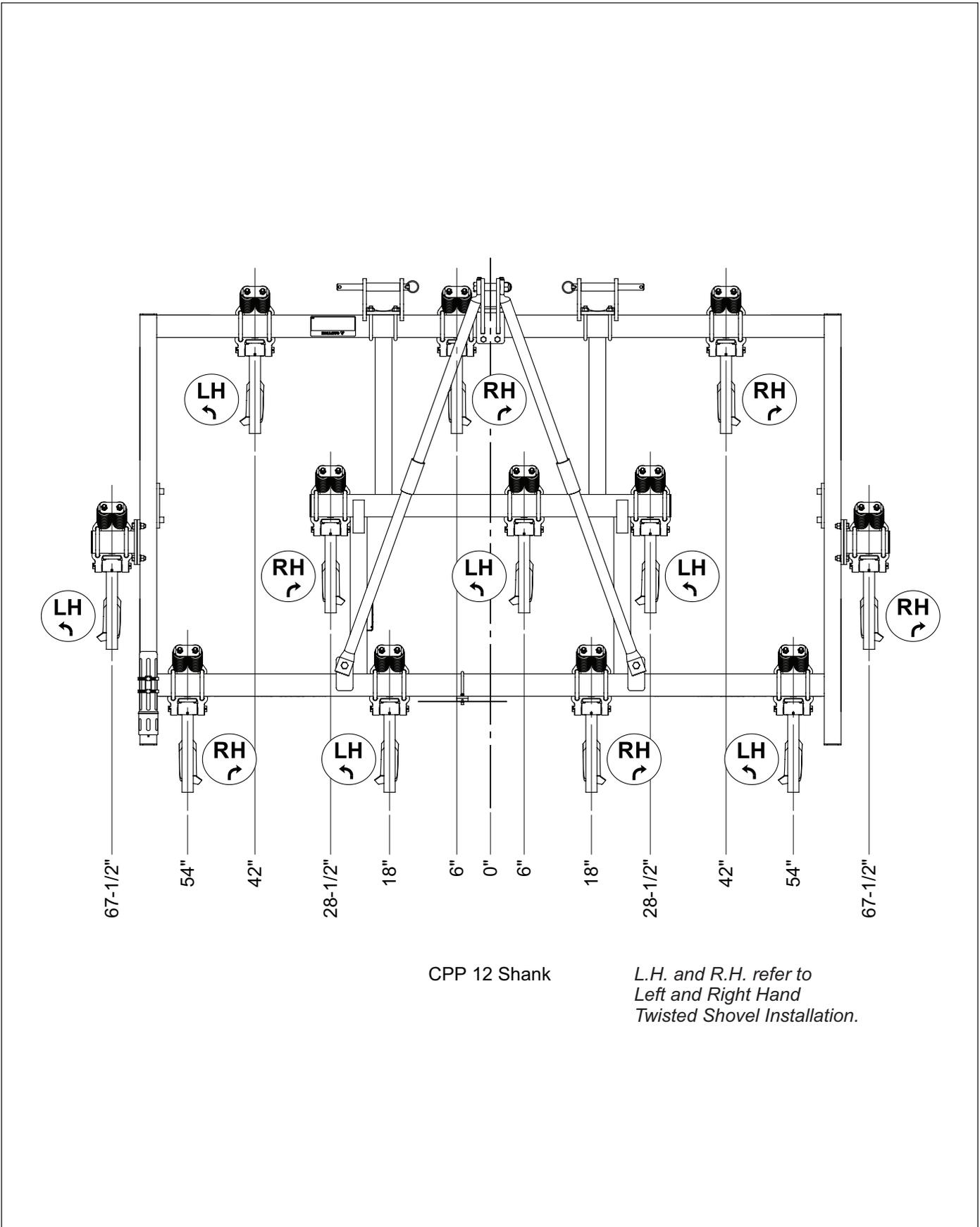
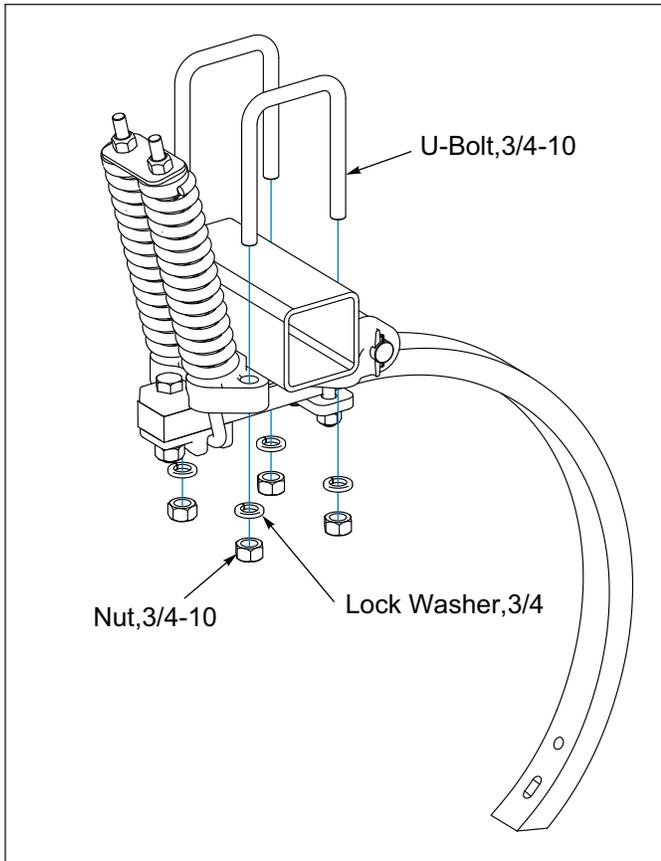

Figure 2-11: CPP12 Shank and Shovel Locations

## Spring Clamp Shank Assembly

Remove the 3/4-10 U-Bolts, Lock Washers and Nuts. Place Shank Assembly Clamp under the frame and re-insert the U-Bolts over the top of the frame and through the Shank Assembly Clamp. Secure with Lock Washer and Nut. See Figure 2-12.



**Figure 2-12: Spring Clamp Shank Assembly**

Check the tension on the Shank Spring. For normal operation the Locknuts on the Spring mounting should be tightened so that one inch of thread is exposed. See Figure 2-13.

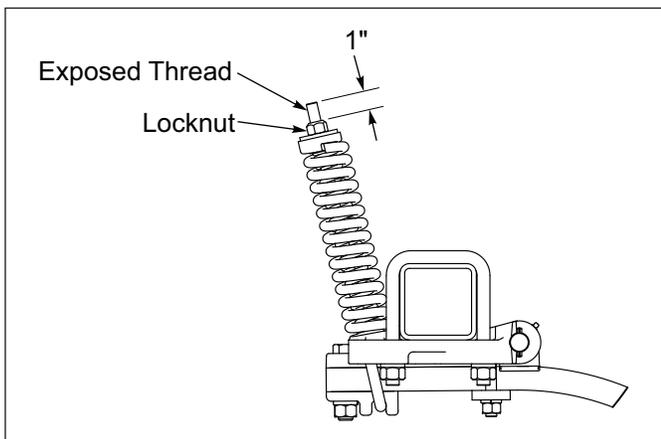

**Figure 2-13: Spring Tension**

## Rigid Clamp Shank Assembly

Remove the front 3/4-10 x 7-1/2 Bolt, Lock Washer and Nut and loosen the 5/8-11 Nuts so that they are flush with the end of the Bolt. Slide the Shank Assembly onto the Frame Tube until the Shank Support seats on the bottom of the Frame Tube. Re-insert the 3/4-10 x 7-1/2 Bolt, Lock Washer and Nut and tighten the 5/8-11 Nuts. See Figure 2-14.

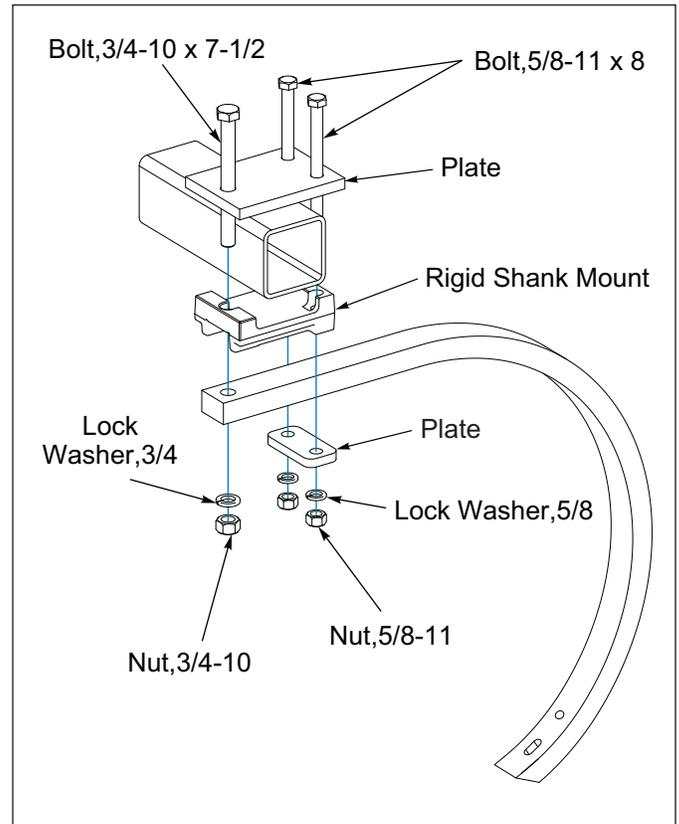

**Figure 2-14: Rigid Clamp Shank Assembly**

## Point Installation

When replacing or reversing points, change all points at the same time so that they will have the same operating depth. If some shanks have worn points, or points of a different design, the chisel plow will not operate efficiently.

### Chisel Plow Point

Install a Chisel Plow Point to each Shank with 1/2-13 x 3 Plow Bolts and Flanged Locknuts. See Figure 2-15.

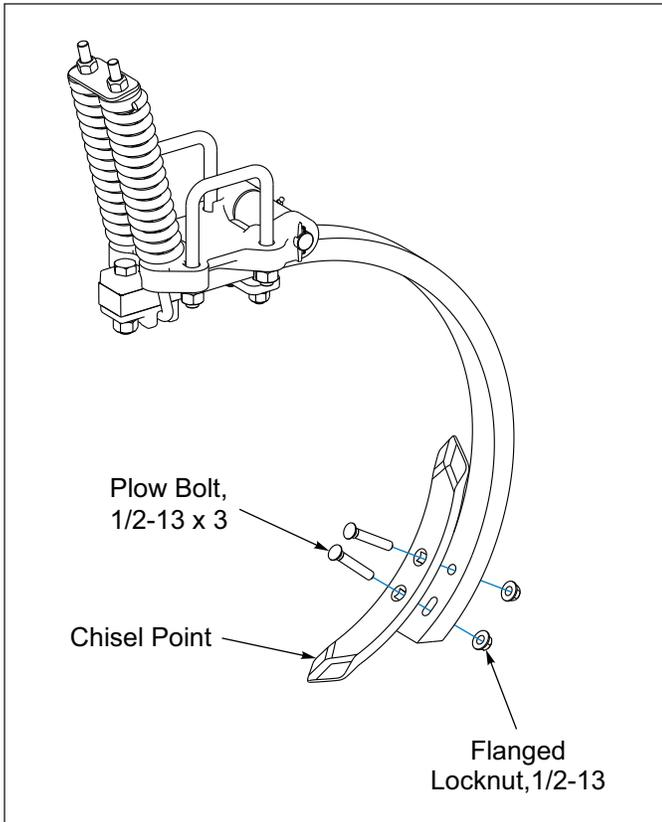

Figure 2-15: Chisel Plow Point

### Twisted Shovels

Install a LH or RH Twisted Shovel per Figures 2-7 to 2-12. to each Shank with 7/16-14 x 2-1/2 Special Plow Bolts and Flanged Locknuts. See Figure 2-16. LH means that the soil is thrown left and RH means that the soil is thrown right. If another arrangement is desired, be sure that the shovels have balanced positions from right side to left side. An example of this would be a LH shovel is the same distance from the center of the machine as a RH shovel is on the opposite side.

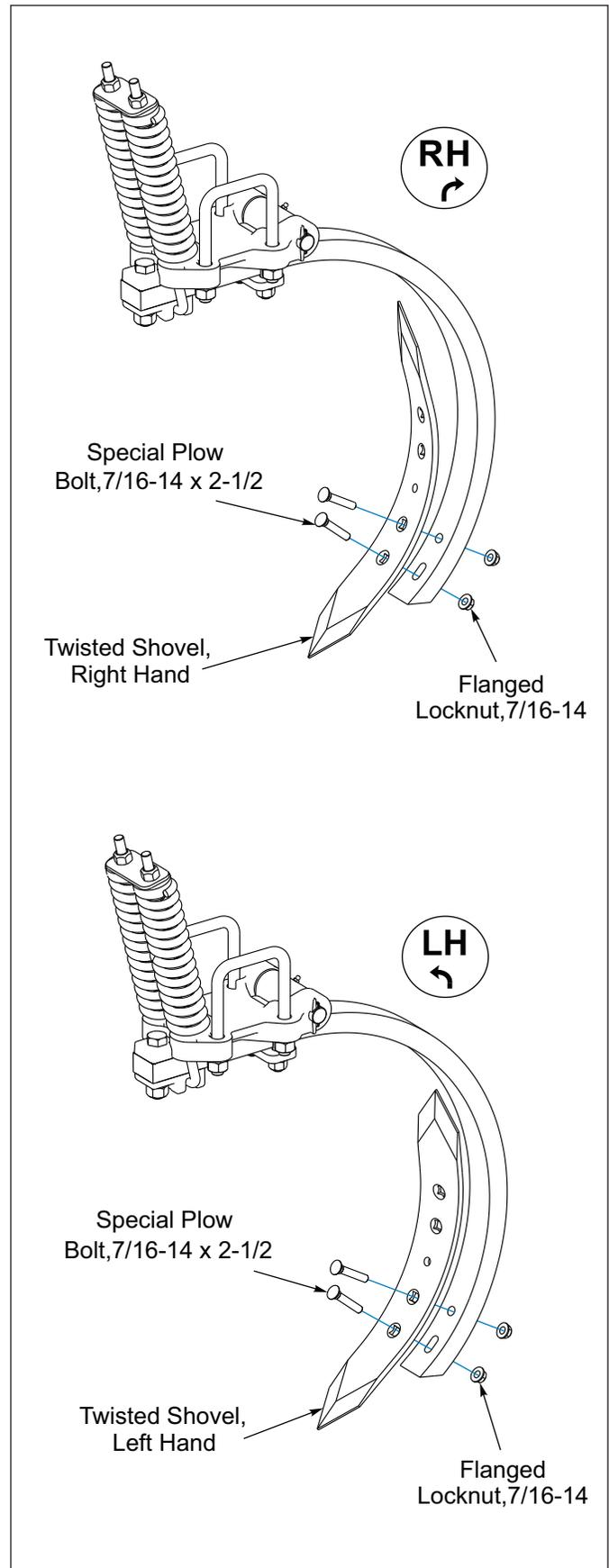

Figure 2-16: Twisted Shovels

## Gauge Wheels Kits - Optional

Place Gauge Wheel Arm between the bar stock that is welded to the 4-Hole Plate on the inside of the outer Frame Tube. Attach Gage Wheel to frame with 4-Hole Plate, 5/8-11 x 3 Bolts, Lock Washers and Nuts. **See Figure 2-17.** Tighten all hardware to the recommended torques and check periodically for looseness.

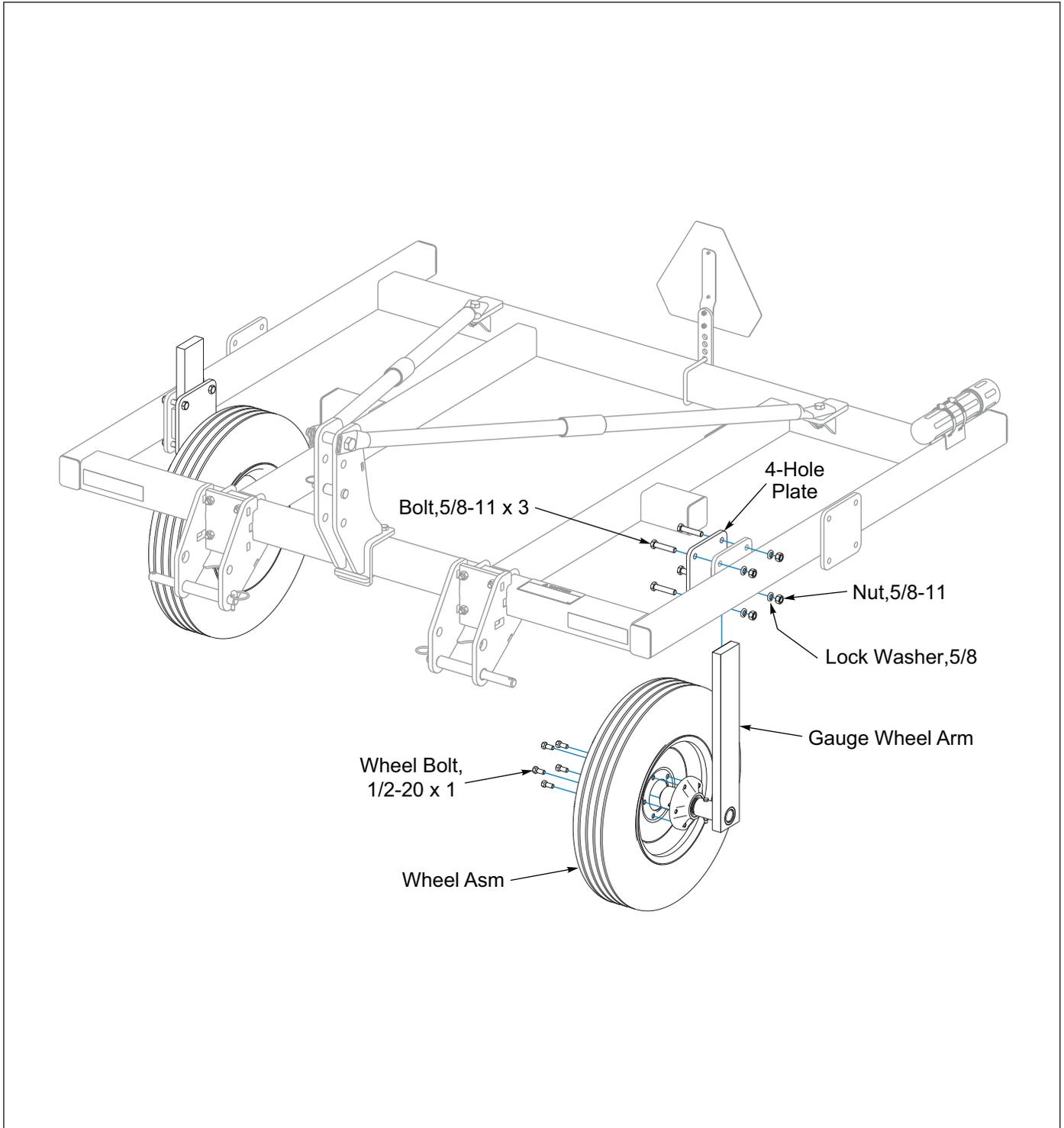

Figure 2-17: Gauge Wheel Kits - Optional

## LED Warning Lights Installation

### **NOTE**

*All models similar. Refer to **Figure 2-18** for bracket and light placement.*

1. Attach the 2 (two) Light Brackets to the rear frame using the 1/2-13 U-Bolts and Nuts. On the 11FT Models the Light Brackets are attached the 2 (two) foot extensions. **See Figures 2-19, 2-19, and 2-21.**
2. Attach Amber LED to the outside of the Light Bracket using (4) 1/4-20 x 1-1/4 Screws and Locknuts, then attach the Red LED next to the Amber LED using (4) 1/4-20 x 1-1/4 Screws and Locknuts
3. Attach the Light Module to the Module Bracket using (2) 1/4-20 x 1-1/2 Screws and Locknuts.
4. Attach the Module Bracket to the top of the rear frame using 2 (two) 3/8-16 U-Bolts and Flange Nuts.
5. Lay out the Lamp Harness, noting that the connectors marked with Green Tape is Right Side and Yellow Tape is Left Side.
6. Connect the Lamp Harness into the Light Module, route the plugs with Green Tape along the top right side of the rear frame. Route the plugs up through the Light Bracket and plug the 3-Prong Cord into the Red LED. Plug the 2-Prong Cord into the Amber LED.
7. **11FT MODEL:** Route the plugs with Green Tape along the top right side of the rear frame. Then up the outer right frame, then over to the 2FT Extension. Route the plugs up through the Light Bracket and plug the 3-Prong Cord into the Red LED. Plug the 2-Prong Cord into the Amber LED.
8. Repeat for the Left Side (Yellow Tape).
9. Plug the 7-Pin Harness into the Light Module, then route the harness along the Right Hand Brace and secure with tie wraps.
10. Bundle and secure excess cord to the Module Bracket with tie wraps. Secure cords along frame and brace using tie wraps.

All wires must be firmly attached to machine frame members so they do not sag or become torn loose by field debris.

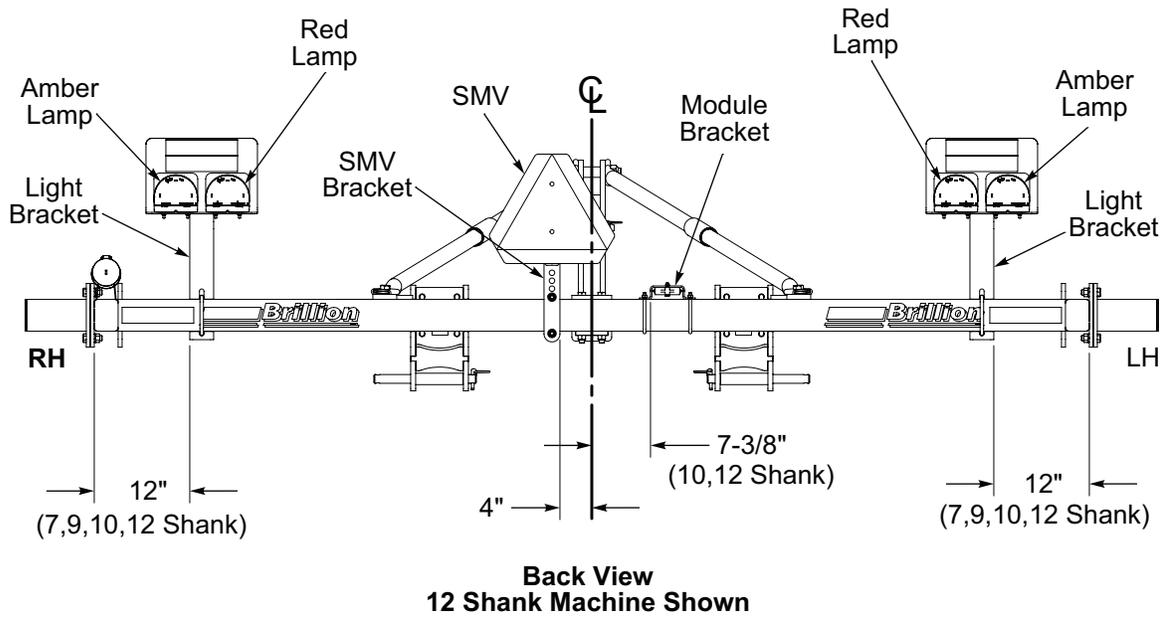
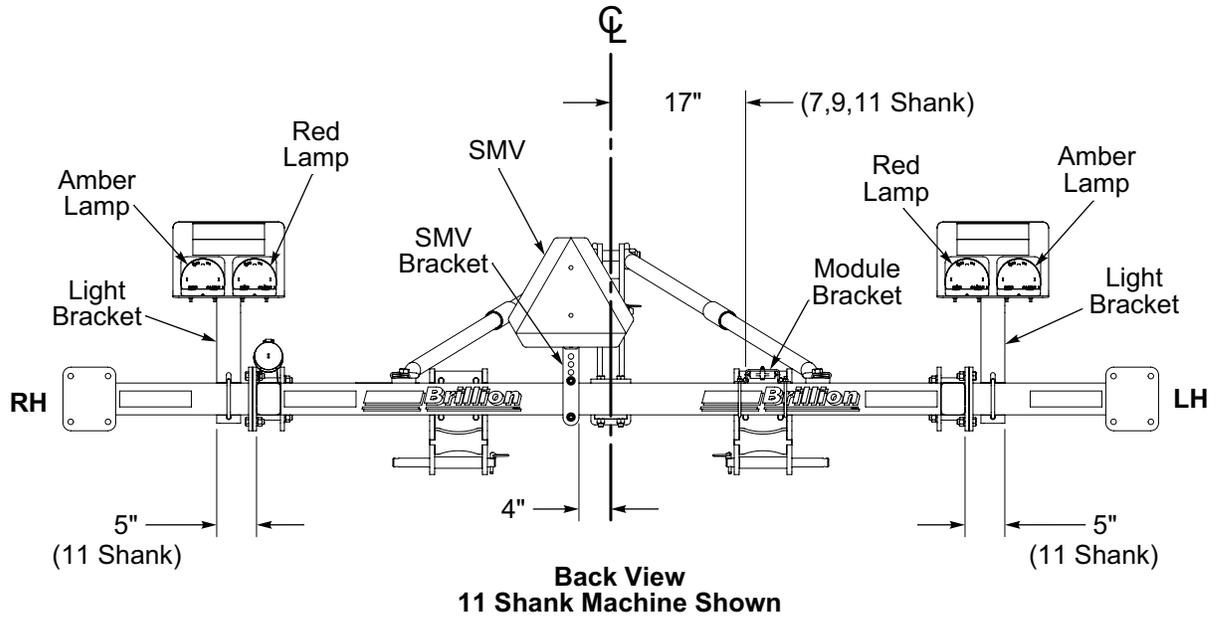

Figure 2-18: Electrical Installation Dimensions

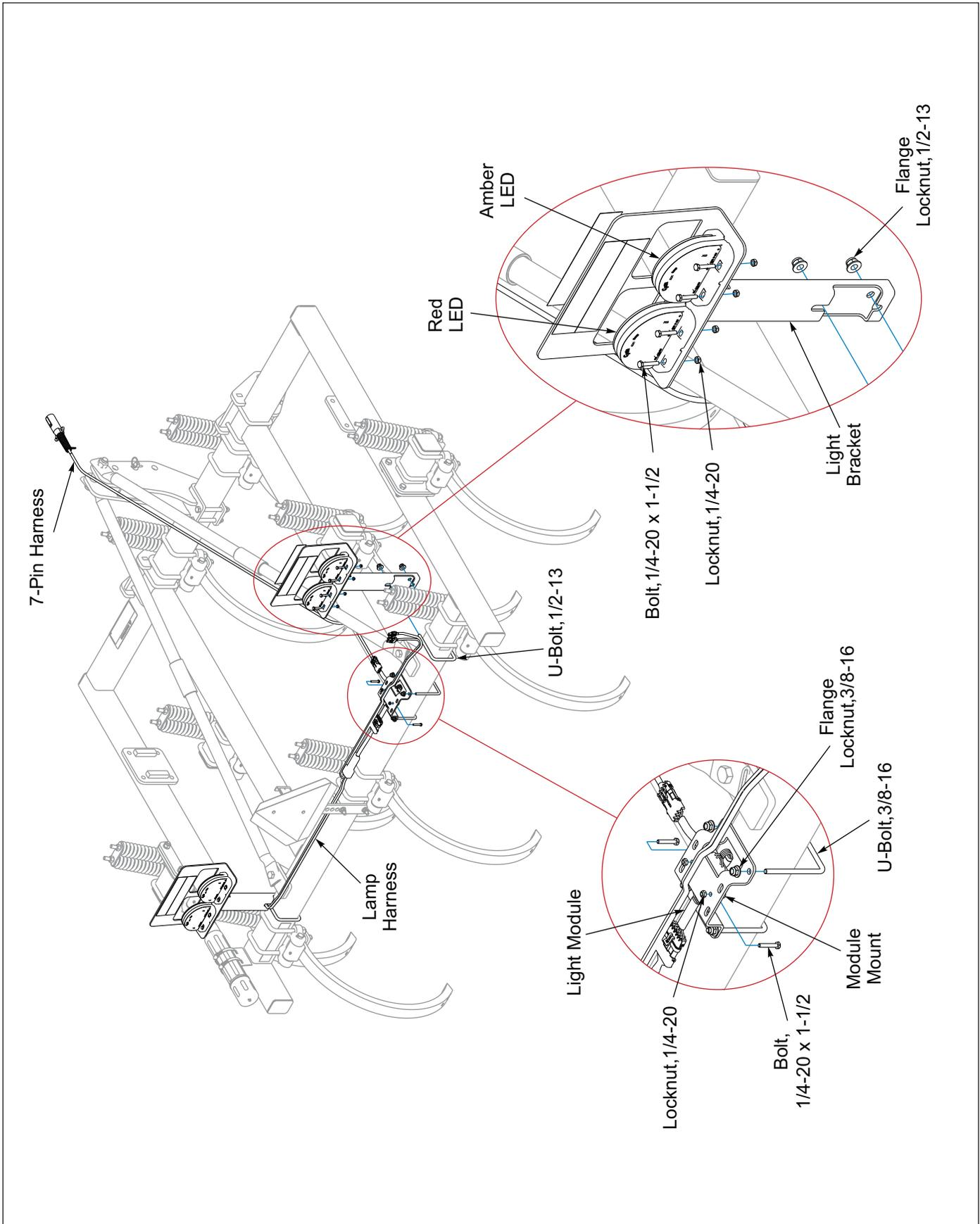

Figure 2-19: 7FT and 9FT LED Warning Lights Layout



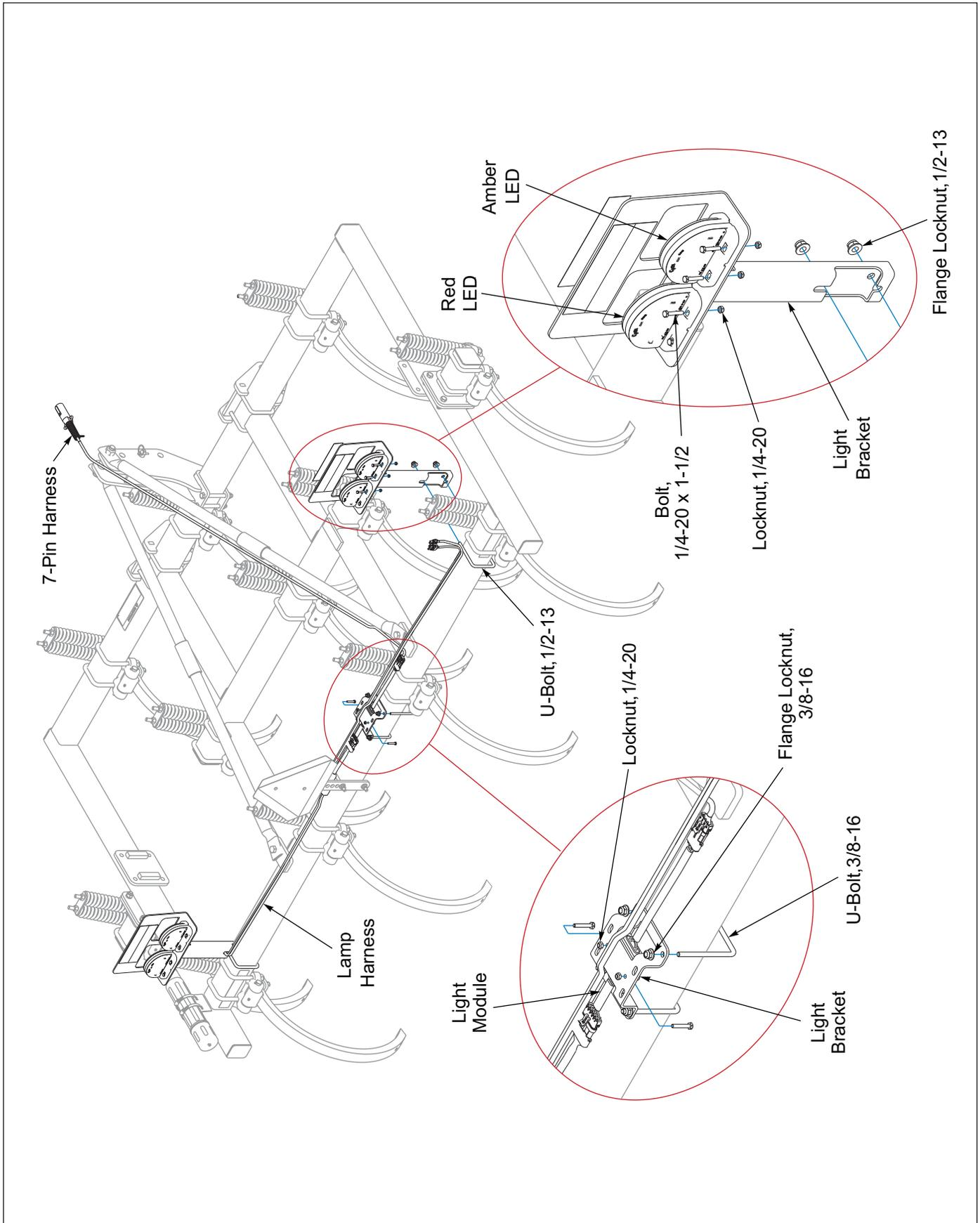

Figure 2-20: 10FT and 12FT LED Warning Lights Layout

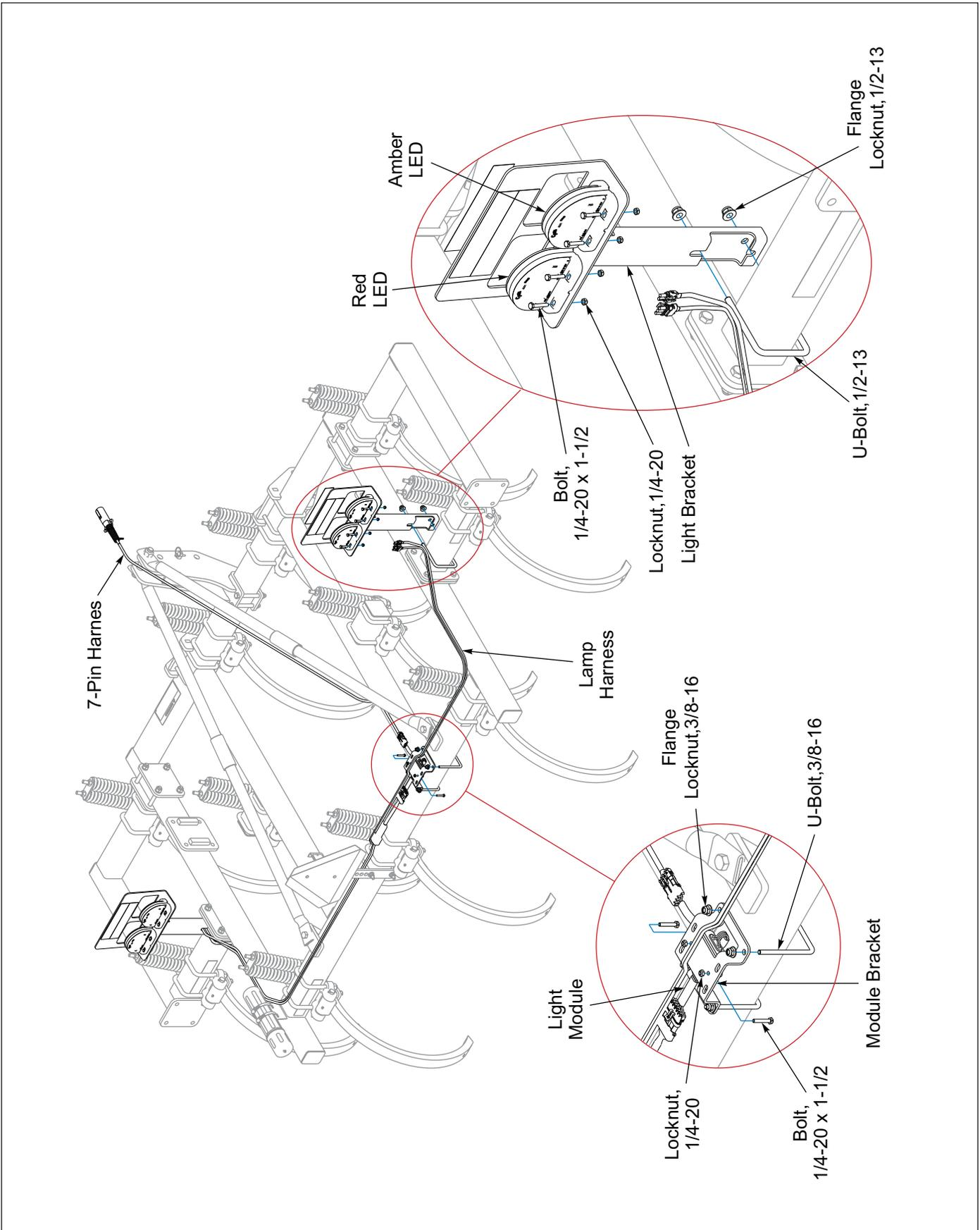

Figure 2-21: 11FT LED Warning Lights Layout

**Never allow anyone to ride on the Chisel Plow at any time. Allowing a person to ride on the machine can inflict serious personal injury or death to that person.**

**When transporting farm implements on public roads, it is the responsibility of the operator to abide by state and local laws concerning wide loads, speed, safety emblems and safety lighting equipment. Drive at safe speeds, particularly when rounding corners, crossing rough ground or driving on hillsides, to prevent tipping the tractor.**

**NOTE**

*This chapter will cover the basic operation and procedures for the Landoll Brillion Chisel Plow. Be sure to read and understand the Safety Procedures and Cautions starting on **Page 1-1**.*

**General**

- The chisel plow loosens the soil to the desired depth, allowing water penetration into the soil. During the winter, the ground will freeze deeper and “weather out” much faster.
- Chisel plowing leaves a mulch and residue cover on the surface, preventing soil surface sealing. Water will be absorbed quickly into the soil, reducing runoff, evaporation and soil erosion. The residue cover also reduces wind erosion.

**Operating Tips**

- To retard downhill water movement on slopes, start at the bottom of the slope and work upwards, parallel to the bottom.
- Chisel the field at an angle to the rows to break up the ridges.

**Operating Speed**

- The chisel works best when operated at a relatively fast speed; 5 mph or faster. If field conditions are adverse, operate at a slower speed to reduce the possibility of implement damage.
- If field conditions are too rough to operate at high speed at the desired depth, make two passes at an angle to each other. Make the first pass shallower than the second pass.

**NOTE**

*Before operating your Brillion machine, check all hardware for tightness. Use the Tightening Torque Table in Chapter 4 as a guide. See "General Torque Specifications" on page 4-1.*

**Tractor Preparation**

The Chisel Plow may be used on tractors equipped with CAT 2 and 3 Free Link or 2, 3 and 3N Quick Coupler 3- PT Hitches. Before attaching the Chisel Plow, prepare the tractor as follows:

- a. The rear tractor tires should be inflated equally and ballast added according to the tractor operator’s manual.
- b. For mounted type models, install front end weights as needed on tractor to maintain stability.

**Do not move tractor without making sure top hitch is connected to tractor.**

**OPERATION**

## Attaching to 3-PT Hitch

1. Carefully back the tractor into place.
2. Attach the Chisel Plow to the tractor.
3. For tractors equipped with Quick Hitches:
  - a. Attach quick hitch to the Chisel Plow
  - b. Raise and make sure lower pin locks are secured.
  - c. Raise the parking stand and pin in fully up position.
  - d. When disconnecting the Chisel Plow, adjust stands to leave the toolbar tilted slightly forward. This will permit easier disconnecting and reattaching.
4. For tractors not equipped with Quick Hitch:
  - a. Attach lower lift arms of the tractor to the Chisel Plow utilizing appropriate pins. Chisel Plow models come with either CAT 2 & 3 or 3 NARROW hitches.
  - b. Attach top link after connecting lower lift arms. Raise parking stands into clamps or remove. When disconnecting, place stand so that the Chisel Plow is stable.
5. Reinstall the stabilizer bars or sway blocks before transporting.
6. Plug in the 7-Pin Connector for the lights.
  - c. Make sure the tractor has a good clean receptacle, free of dirt and corrosion.
  - d. Make sure the 7-Pin Connector is inserted ALL the way in. With tighter fitting pins, operator may think the connector is all the way in, but really isn't.
  - e. Make sure the tractor receptacle cover latches over the keyway on the 7-Pin Connector to hold the connector in place.
  - f. If an operator plugs in the 7-Pin Connector, but the lights do not seem to work right, check the above items to make sure there is a good connection with the 7-Pin Connector.

## Field Operation

1. Lower the Chisel Plow to the ground and pull it a few feet at the approximate desired depth.
2. Check for front-to-rear levelness. Level the frame by adjusting the 3-PT Hitch Top Link until the frame is level to the ground.
  - a. Set shank depth by adjusting the max depth stop on the 3-Point Control in the tractor.
  - b. Set shank depth by adjusting both Optional Gauge Wheels the same direction from the bottom of the tire to the tip of the Shank, which is the approximate working depth of the Shank. Loosen the 5/8-11 x 3 Bolts without removing the Nuts and raise or lower the Gauge Wheels to the desired depth. Tighten all hardware to the recommended torques and check periodically for looseness. **See "General Torque Specifications" on page 4-1.**
3. Always lift the Chisel Plow completely out of the ground before turning or backing to prevent shank or coulter damage or damage to their respective mounting brackets.
4. Reduce speed at field ends, raise the Chisel Plow out of the ground.
5. After a few hours of initial operation, check all hardware for tightness. Tighten any loose Hardware.

## Spring Shank Tension Adjustment

For normal operation, the Locknuts on the Spring mounting should be tightened so that one inch of thread is exposed. **See Figure 3-1.**

In tougher soil you may want to increase the Spring tension or compress the spring more. Keep in mind that when this is done, the shank and tooth will not pass over as great of obstruction.

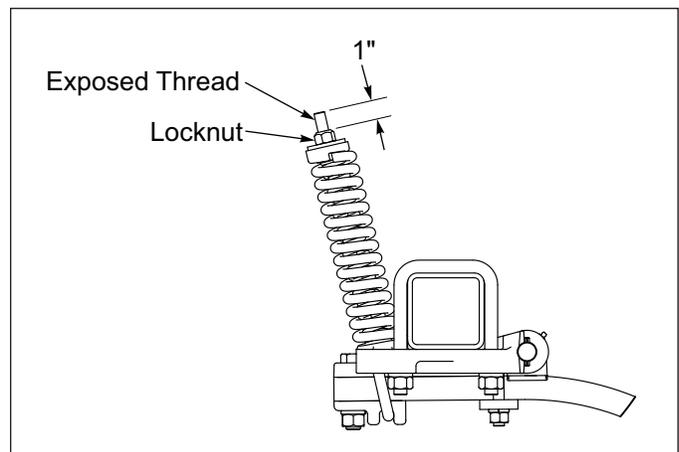

**Figure 3-1: Spring Tension**

# Transport

1. Check and follow all federal, state, and local requirements before transporting the Chisel Plow.
2. The Chisel Plow should be transported only by tractor required for field operation. The implement weight should not exceed more than 1.5 times the tractor weight. Maximum transport speed for the Chisel Plow is 20 mph.

**Excessive speed may result in loss of control of the tractor and implement, reduced braking ability, or failure of the implement tire or structure. Do not exceed the implement maximum specified ground speed regardless of the capability of the maximum tractor speed.**

3. When towing equipment in combination, the maximum equipment ground speed shall be limited to the lowest specified ground speed of any of the towed implements.

Maximum transport speed shall be the lesser of travel speed specified in the operator's manual, speed identification symbol, information sign of towed equipment, or limit of road conditions.

4. Slow down when driving on rough roads. Reduce speed when turning, or on curves and slopes to avoid tipping. Equipment altered other than the place of manufacture may reduce the maximum transport speed. Additional weight, added tanks, harrowing attachments, etc. may reduce implement load carrying capabilities.
5. Before transporting:
  - Know the transport heights and widths of the unit before transporting. Use caution when transporting near bridges and power lines.

**Stay away from power lines when transporting, extending implement. Electrocutation can occur without direct contact.**

- Check to see that the tractor hitch capacity is rated to carry the weight of the Seeder Hitch. **Refer to Tractor's Operator's Manual.**
- Connect the Safety Warning Lights 7-Pin Plug into tractor 7-Pin outlet, routing cord by avoiding pinch points.
- Raise the machine to full transport height.

- Check all tires for proper inflation, and that lug nuts are properly torque. **See "Tires" on page 4-2.**
- Verify that all warning lights, SMV sign, reflectors, and safety decals are clearly visible and functioning properly.
- Transport during daylight hours when ever possible. Always use flashing warning lights, except where such use is prohibited by law. Make sure lights, reflectors and SMV emblem are clearly visible and operating. Remove any obstructions such as dirt, mud, stalks or residue that restricts view before transporting. **See Figure 3-2.**

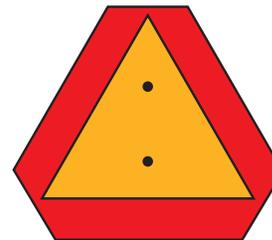

**Figure 3-2: SMV Sign**



## General Torque Specifications

(rev. 4/97)

This chart provides tightening torques for general purpose applications when special torques are not specified on process or drawing. Assembly torques apply to plated nuts and capscrews assembled without supplemental lubrication (as received condition). They do not apply if special graphite moly-disulfide or other extreme pressure lubricants are used. When fasteners are dry (solvent cleaned) add 33% to as received condition torque. Bolt head identification marks indicate grade and may vary from manufacturer to manufacturer. Thick nuts must be used on grade 8 capscrews. Use value in [ ] if using prevailing torque nuts.

### TORQUE SPECIFIED IN FOOT POUNDS

UNF SIZE	SAE Grade 2	SAE Grade 5	SAE Grade 8	UNF SIZE	SAE Grade 2	SAE Grade 5	SAE Grade 8
1/4-20	4 [5]	6 [7]	9 [11]	1/4-28	5 [6]	7 [9]	10 [12]
5/16-18	8 [10]	13 [13]	18 [22]	5/16-24	9 [11]	14 [17]	20 [25]
3/8-16	15 [19]	23 [29]	35 [42]	3/8-24	17 [21]	25 [31]	35 [44]
7/16-14	24 [30]	35 [43]	55 [62]	7/16-20	27 [34]	40 [50]	60 [75]
1/2-13	35 [43]	55 [62]	80 [100]	1/2-20	40 [50]	65 [81]	90 [112]
9/16-12	55 [62]	80 [100]	110 [137]	9/16-18	60 [75]	90 [112]	130 [162]
5/8-11	75 [94]	110 [137]	170 [212]	5/8-18	85 [106]	130 [162]	180 [225]
3/4-10	130 [162]	200 [250]	280 [350]	3/4-16	150 [188]	220 [275]	320 [400]
7/8-9	125 [156]	320 [400]	460 [575]	7/8-14	140 [175]	360 [450]	500 [625]
1-8	190 [237]	408 [506]	680 [850]	1-14	210 [263]	540 [675]	760 [950]
1-1/8-7	270 [337]	600 [750]	960 [1200]	1-1/8-12	300 [375]	660 [825]	1080 [1350]
1-1/4-7	380 [475]	840 [1050]	1426 [1782]	1-1/4-12	420 [525]	920 [1150]	1500 [1875]
1-3/8-6	490 [612]	1010 [1375]	1780 [2225]	1-3/8-12	560 [700]	1260 [1575]	2010 [2512]
1-1/2-6	650 [812]	1460 [1825]	2360 [2950]	1-1/2-12	730 [912]	1640 [2050]	2660 [3325]

### METRIC:

Coarse thread metric class 10.9 fasteners and class 10.0 nuts and through hardened flat washers, phosphate coated, Rockwell "C" 38-45. Use value in [ ] if using prevailing torque nuts.

Nominal thread diameter (mm)	Newton Meters (Standard Torque)	Foot Pounds (Standard Torque)	Nominal Thread Diameter (mm)	Newton Meters (Standard Torque)	Foot Pounds (Standard Torque)
6	10 [14]	7 [10]	20	385 [450]	290 [335]
7	16 [22]	12 [16]	24	670 [775]	500 [625]
8	23 [32]	17 [24]	27	980 [1105]	730 [825]
10	46 [60]	34 [47]	30	1330 [1470]	990 [1090]
12	80 [125]	60 [75]	33	1790 [1950]	1340 [1450]
14	125 [155]	90 [115]	36	2325 [2515]	1730 [1870]
16	200 [240]	150 [180]	39	3010 [3210]	2240 [2380]
18	275 [330]	205 [245]			

**MAINTENANCE**

# Fasteners

Before operating your Brillion machine, check all hardware for tightness. Use the Tightening Torque Table as a guide. **See "General Torque Specifications" on page 4-1.**

After a few hours of use, check entire machine and tighten any loose nuts or bolts. Daily or periodic checks should be made thereafter.

When replacing bolts, be sure to use fasteners of equal grade.

# Tires

Recommended tire sizes are 7.6 x 15-6 Ply Tire and should be inflated to 40 PSI.

When Re-Installing the Wheel Nuts tighten to 50 foot-pounds using the sequence in **Figure 4-1**. Then tighten to full torque of 85-100 Ft-lbs.

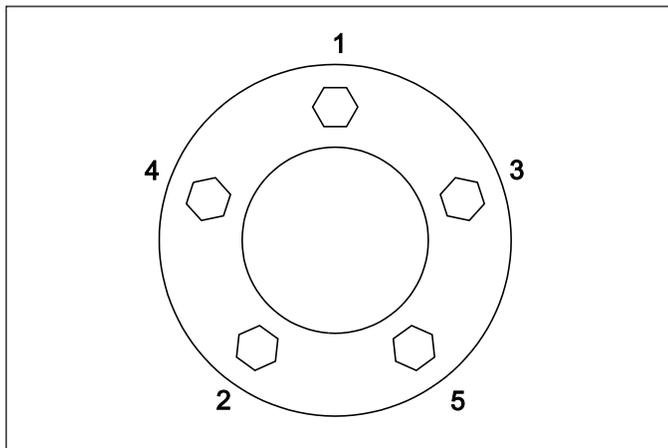

**Figure 4-1: Stud Tightening Sequence**

# Points

**NOTE**

*When replacing or reversing point, change all points at the same time so that they will have the same operating depth. If some shanks have worn points, or points of a different design, the Chisel Plow will not operate efficiently.*

# Lubrication Maintenance

- Wheel Hub Lubrication should be performed at the beginning of every season of use. Check the wheel bearings periodically for excessive end play.
- Grease Wheel Hubs every 50 hours. **See Figure 4-2.**
- Grease Spring Shank Clamp every 10 Hours to prevent seizure. **See Figure 4-3.**

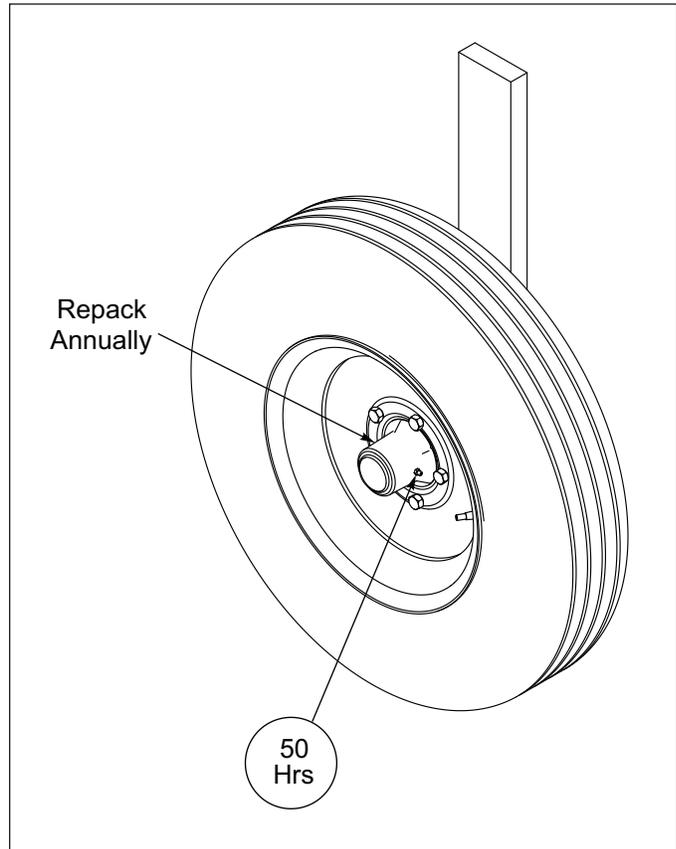

**Figure 4-2: Wheel Hub Lubrication**

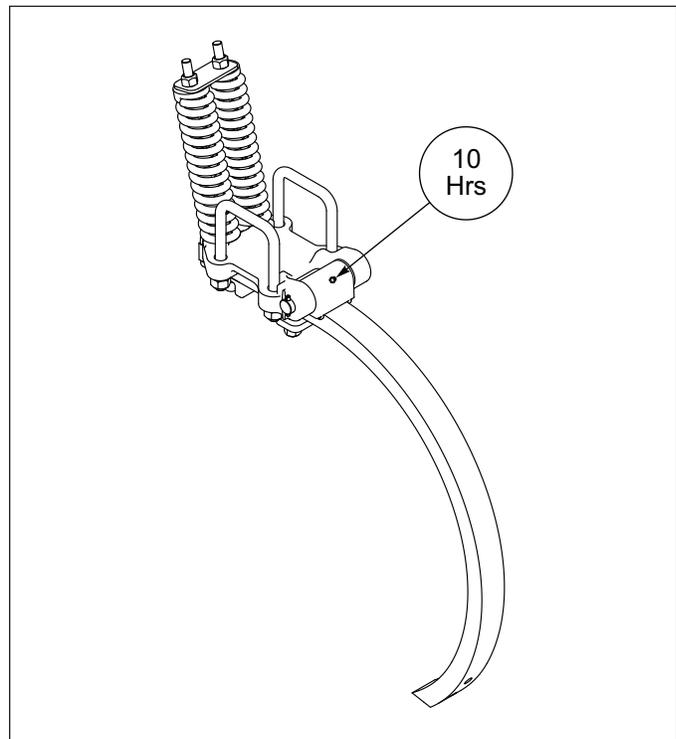

**Figure 4-3: Spring Shank Lubrication**



## Warning Lamps

When plugging in the 7-Pin Warning Lamp Connector:

1. Make sure the Tractor has a good clean Receptacle, free of dirt and corrosion.
2. Make sure the 7-Pin Connector is inserted ALL the way in. With tighter fitting pins, operator may think the Connector is all the way in, but it really isn't.
3. Make sure the Tractor Receptacle Cover latches over the keyway on the 7-Pin Connector to hold the Connector in place.

If an operator plugs in the 7-Pin Connector, but the lights Do Not seem to work right, check the above items to make sure there is a good connection with the 7-Pin Connector.

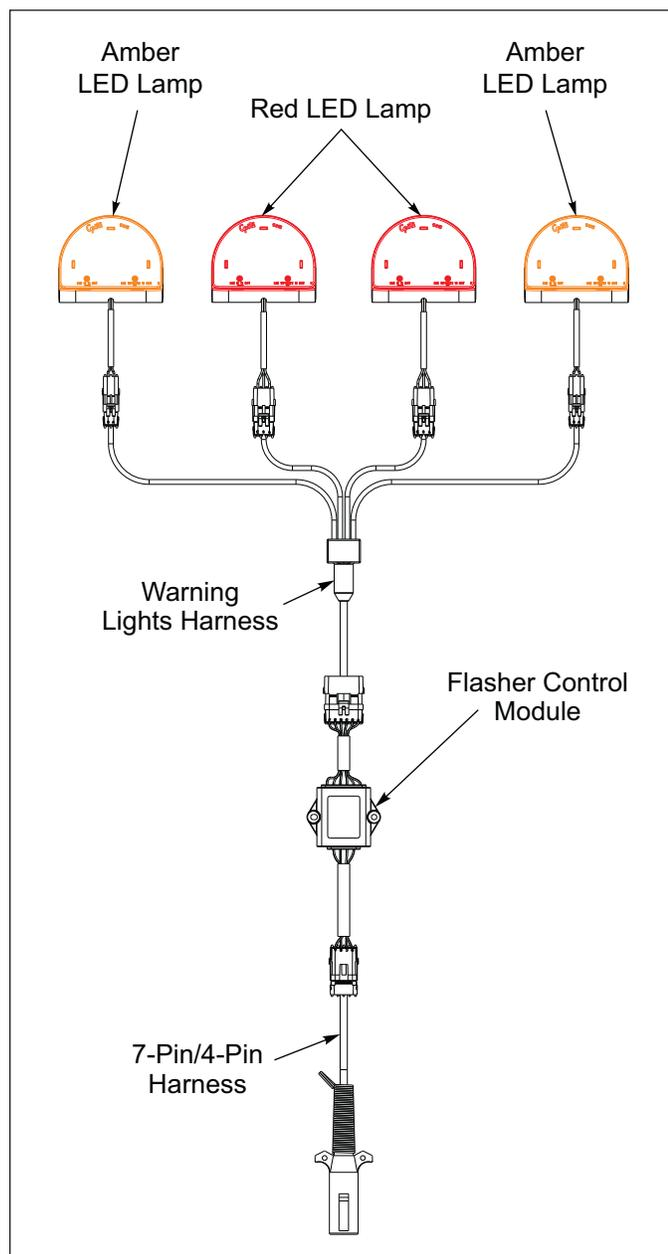

Figure 4-4: Warning Lamps

## Storage

1. The service life of the Chisel Plow will be extended by proper off-season storage practices. Prior to storing the unit, complete the following procedures:
  - Completely clean the unit.
  - Inspect the machine for worn or defective parts. Replace as needed.
  - Repaint all areas where the original paint is worn off.
  - Grease all exposed metal surfaces of Shanks and Points.
2. Store the unit in a shed or under a tarpaulin to protect it from the weather. The ground tools and tires should rest on boards, or some other object, to keep them out of the soil.



Specifications

Product Attributes	CPP-7	CPP-9
Approximate Weight	604 lbs. (272 kg)	636 lbs. (286 kg)
Working Width	7 ft. 0 in. (2.1 m)	9 ft. 0 in. (2.7 m)
Transport Width	7 ft. 6 in. (2.25 m)	8 ft. 7 in. (2.58 m)
Transport Height	4 ft. 8 in. (1.4 m)	4 ft. 8 in. (1.4 m)
Overall Length	8 ft. 0 in. (2.4 m)	8 ft. 0 in. (2.4 m)
Number of Shanks	7	9
Shank Mount	Rigid or Dual Nested Spring	Rigid or Dual Nested Spring
Shank Size	1 in. x 2 in. x 26 in. (25.4 x 50.8 x 660 mm)	1 in. x 2 in. x 26 in. (25.4 x 50.8 x 660 mm)
	1.25 in. x 2 in. x 32 in. (31.3 x 50.8 x 813 mm)	1.25 in. x 2 in. x 32 in. (31.3 x 50.8 x 813 mm)
	1.25 in. x 2 in. x 26 in. (31.3 x 50.8 x 660 mm)	1.25 in. x 2 in. x 26 in. (31.3 x 50.8 x 660 mm)
Shank Spacing	12 in. (300 mm)	12 in. (300 mm)
Shank Working Depth	Maximum 12 in. (300 mm)	Maximum 12 in. (300 mm)
Spring Pressure / Trip Resistance	550 lbs. to 825 lbs. (248 kg to 371 kg)	550 lbs. to 825 lbs. (248 kg to 371 kg)
Shank Trip Height	5.5 in. (138 mm)	5.5 in. (138 mm)
Chisel Points Available	2 in. (50.8 mm) Reversible Point or 3 in. (76.2 mm) Reversible Twisted Point	2 in. (50.8 mm) Reversible Point or 3 in. (76.2 mm) Reversible Twisted Point
Under Frame Clearance	27.5 in. or 33.5 in. (688 or 838 mm)	27.5 in. or 33.5 in. (688 or 838 mm)
Frame Structure	4 in. x 4 in. x .25 in. (100 x 100 x 6.35 mm)	4 in. x 4 in. x .25 in. (100 x 100 x 6.35 mm)
Three-Point Hitch	Cat. II, III Free Link; Cat. II, III, IIIN Quick Coupler	Cat. II, III Free Link; Cat. II, III, IIIN Quick Coupler
Safety Warning Lights & SMV Emblem	Standard	Standard
Powder Coat Paint, Red	Standard	Standard
Optional Equipment	Manual Adjust Gauge Wheel Kit Shank and Clamp Assemblies Frame Extension Kits	Manual Adjust Gauge Wheel Kit Shank and Clamp Assemblies Frame Extension Kits
Horsepower Requirements	10 to 15 HP (8 to 11 kW) per Shank	10 to 15 HP (8 to 11 kW) per Shank
Recommended Operating Speed	4 to 6 MPH (6.43 to 9.65 km/h)	4 to 6 MPH (6.43 to 9.65 km/h)

Specifications subject to change with or without notice.

Figure 5-1: Model Specifications (1 of 3)

## TABLE OF CONTENTS

### SPECIFICATIONS

Product Attributes	CPP-10	CPP-11
Approximate Weight	723 lbs. (325 kg)	779 lbs. (351 kg)
Working Width	10 ft. 0 in. (3.0 m)	11 ft. 0 in. (3.4 m)
Transport Width	10 ft. 6 in. (3.15 m)	11 ft. 6 in. (3.45 m)
Transport Height	4 ft. 8 in. (1.4 m)	4 ft. 8 in. (1.4 m)
Overall Length	8 ft. 0 in. (2.4 m)	8 ft. 0 in. (2.4 m)
Number of Shanks	10	11
Shank Mount	Rigid or Dual Nested Spring	Rigid or Dual Nested Spring
Shank Size	1 in. x 2 in. x 26 in. (25.4 x 50.8 x 660 mm)	1 in. x 2 in. x 26 in. (25.4 x 50.8 x 660 mm)
	1.25 in. x 2 in. x 32 in. (31.3 x 50.8 x 813 mm)	1.25 in. x 2 in. x 32 in. (31.3 x 50.8 x 813 mm)
	1.25 in. x 2 in. x 26 in. (31.3 x 50.8 x 660 mm)	1.25 in. x 2 in. x 26 in. (31.3 x 50.8 x 660 mm)
Shank Spacing	12 in. (300 mm)	12 in. (300 mm)
Shank Working Depth	Maximum 12 in. (300 mm)	Maximum 12 in. (300 mm)
Spring Pressure / Trip Resistance	550 lbs. to 825 lbs. (248 kg to 371 kg)	550 lbs. to 825 lbs. (248 kg to 371 kg)
Shank Trip Height	5.5 in. (138 mm)	5.5 in. (138 mm)
Chisel Points Available	2 in. (50.8 mm) Reversible Point or 3 in. (76.2 mm) Reversible Twisted Point	2 in. (50.8 mm) Reversible Point or 3 in. (76.2 mm) Reversible Twisted Point
Under Frame Clearance	27.5 in. or 33.5 in. (688 or 838 mm)	27.5 in. or 33.5 in. (688 or 838 mm)
Frame Structure	4 in. x 4 in. x .25 in. (100 x 100 x 6.35 mm)	4 in. x 4 in. x .25 in. (100 x 100 x 6.35 mm)
Three-Point Hitch	Cat. II, III Free Link; Cat. II, III, IIIN Quick Coupler	Cat. II, III Free Link; Cat. II, III, IIIN Quick Coupler
Safety Warning Lights & SMV Emblem	Standard	Standard
Powder Coat Paint, Red	Standard	Standard
Optional Equipment	Manual Adjust Gauge Wheel Kit Shank and Clamp Assemblies Frame Extension Kits	Manual Adjust Gauge Wheel Kit Shank and Clamp Assemblies Frame Extension Kits
Horsepower Requirements	10 to 15 HP (8 to 11 kW) per Shank	10 to 15 HP (8 to 11 kW) per Shank
Recommended Operating Speed	4 to 6 MPH (6.43 to 9.65 km/h)	4 to 6 MPH (6.43 to 9.65 km/h)

*Specifications subject to change with or without notice.*

**Figure 5-2: Model Specifications (2 of 3)**

<b>Product Attributes</b>	<b>CPP-12</b>
<b>Approximate Weight</b>	755 lbs. (340 kg)
<b>Working Width</b>	12 ft. 0 in. (3.6 m)
<b>Transport Width</b>	11 ft. 11 in. (3.6 m)
<b>Transport Height</b>	4 ft. 8 in. (1.4 m)
<b>Overall Length</b>	8 ft. 0 in. (2.4 m)
<b>Number of Shanks</b>	12
<b>Shank Mount</b>	Rigid or Dual Nested Spring
<b>Shank Size</b>	1 in. x 2 in. x 26 in. (25.4 x 50.8 x 660 mm) 1.25 in. x 2 in. x 32 in. (31.3 x 50.8 x 813 mm) 1.25 in. x 2 in. x 26 in. (31.3 x 50.8 x 660 mm)
<b>Shank Spacing</b>	12 in. (300 mm)
<b>Shank Working Depth</b>	Maximum 12 in. (300 mm)
<b>Spring Pressure / Trip Resistance</b>	550 lbs. to 825 lbs. (248 kg to 371 kg)
<b>Shank Trip Height</b>	5.5 in. (138 mm)
<b>Chisel Points Available</b>	2 in. (50.8 mm) Reversible Point or 3 in. (76.2 mm) Reversible Twisted Point
<b>Under Frame Clearance</b>	27.5 in. or 33.5 in. (688 or 838 mm)
<b>Frame Structure</b>	4 in. x 4 in. x .25 in. (100 x 100 x 6.35 mm)
<b>Three-Point Hitch</b>	Cat. II, III Free Link; Cat. II, III, IIIN Quick Coupler
<b>Safety Warning Lights &amp; SMV Emblem</b>	Standard
<b>Powder Coat Paint, Red</b>	Standard
<b>Optional Equipment</b>	Manual Adjust Gauge Wheel Kit Shank and Clamp Assemblies Frame Extension Kits
<b>Horsepower Requirements</b>	10 to 15 HP (8 to 11 kW) per Shank
<b>Recommended Operating Speed</b>	4 to 6 MPH (6.43 to 9.65 km/h)

*Specifications subject to change with or without notice.*

**Figure 5-3: Model Specifications (3 of 3)**



# Document Control Revision Log:

Date	Form #	Improvement(s): Description and Comments
07/2001	7D525-0701	New Release
11/2013	7D525-1113	Updated to Landoll Format. Added LED Warning Lights
01/2024	7D525-2401	Revised Landoll Template, Updated Shank Dimension Drawings, Specs *Revised Form Format "Year/Date" Updated ISO logos to ISO 9001:2015 (Revised 04/2024)



**intertek**

Equipment from Landoll Company, LLC is built to  
exacting standards ensured by ISO 9001:2015 registration  
at all Landoll manufacturing facilities.

# **Chisel Plow, 3-Bar Mounted Models: CPP7 thru CPP12 Operator's Manual**

## **Re-Order Part Number 7D525**

**LANDOLL COMPANY, LLC**

1900 North Street

Marysville, Kansas 66508

(785) 562-5381

**800-428-5655 ~ WWW.LANDOLL.COM**



Copyright 2024. Landoll Company, LLC

“All rights reserved, including the right to reproduce this material or portions thereof in any form.”

