

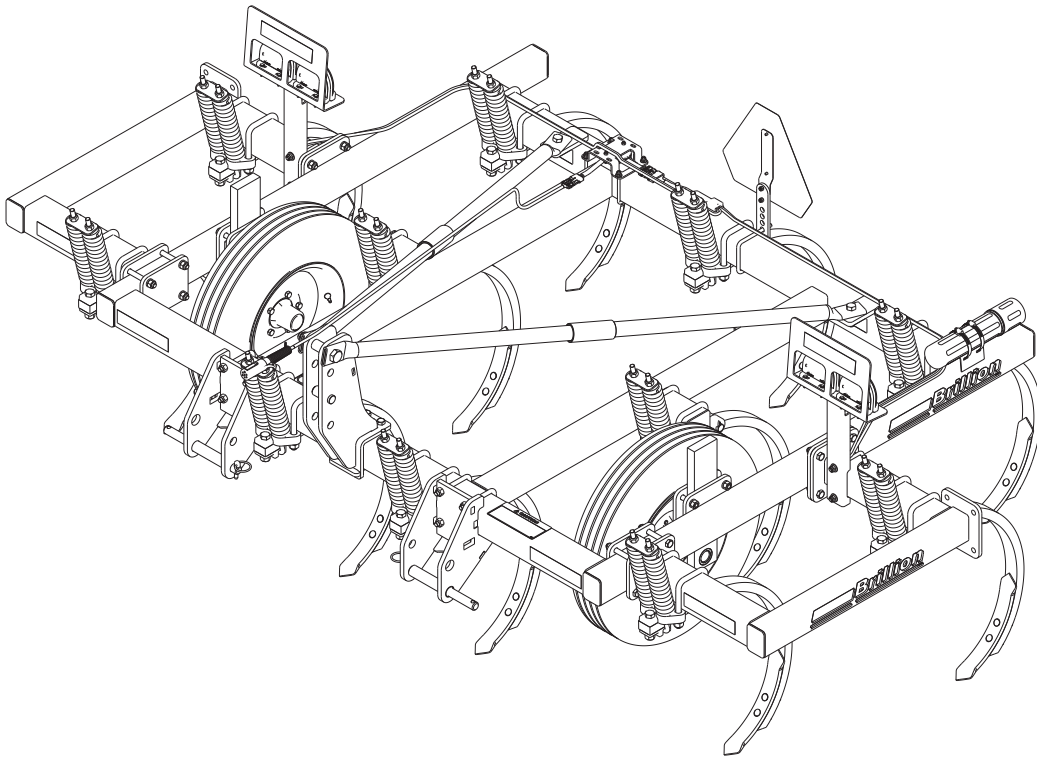

Chisel Plow, 3-Bar Mounted Models: CPP7 thru CPP12 Parts Manual



LANDOLL COMPANY, LLC

1900 North Street

Marysville, Kansas 66508

(785) 562-5381

800-428-5655 ~ WWW.LANDOLL.COM

Manuals for 3-Bar Mounted, Chisel Plow

Manual Number	Manual Type
7D525	Operator's Manual
7D524	Parts Manual

Table of Contents

1 Illustrated Parts List

Instructions for Ordering Parts	1-1
Frame (7 and 9 Shank Models)	1-2
Frame (10 and 12 Shank Models)	1-4
Frame (11 Shank Model)	1-6
Shank and Spring Clamp Assembly	1-8
Spring Shank Assembly	1-10
Rigid Shank Assembly	1-12
Points	1-13
LED Warning Lights (7 and 9 Shank Models)	1-14
LED Warning Lights (10 and 12 Shank Models)	1-16
LED Warning Lights (11 Shank Model)	1-18
Extension Kit, 2FT - Optional	1-20
Extension Kit, 4FT - Optional	1-21
Bracket Assemblies - Optional (Before 04/2016)	1-22
Gauge Wheel Kit, 32" - Optional	1-23
Gauge Wheel Kit, 26" - Optional	1-24
Hub and Bar Assembly, 1J402	1-25
Hub and Bar Assembly, 1J404	1-26
Hub and Spindle Assembly	1-27
Wheel and Tire	1-28
Decals	1-29
Decal Locations	1-30

2 Glossary

3 Index

Illustrated Parts List

Instructions for Ordering Parts

**** Repair parts must be ordered through an authorized dealer ****

DEALER INSTRUCTIONS FOR ORDERING PARTS FROM LANDOLL PARTS DISTRIBUTION CENTER

PHONE #: 800-423-4320 OR 785-562-5381

FAX #: 888-527-3909

ORDER ONLINE: Dealer.landoll.com

IDENTIFICATION PLATE

See Figure 1-1 for the Identification Plate, which lists the model and serial number of the equipment. It is located on the rear left hand, inside frame of the Chisel Plow.

SERIAL NUMBER NOMENCLATURE

The serial number for the Chisel is located on the identification plate. The following information will help decode the Landoll serial number.

CPD24000100 = xxmyysss

xx	= model series (i.e. "CP" for all Chisel Plows)
m	= month of manufacture (ex. "D" means April. The letter I is not used.)
yy	= last digits of the year manufactured (ex. "24" means 2024)
sss	= Sequential number used to track warranty and service information.

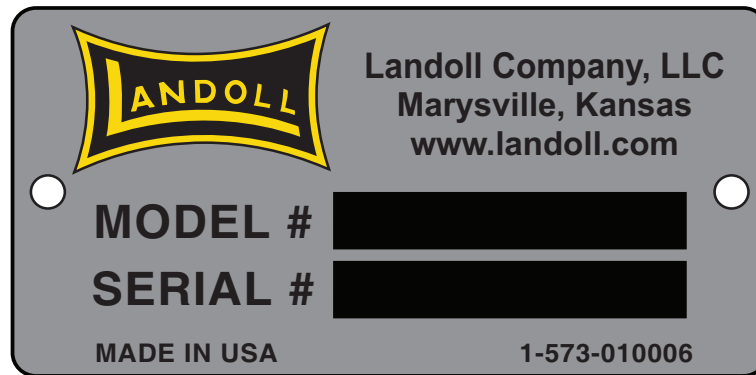

Figure 1-1: Identification Plate

ILLUSTRATED PARTS LIST

Frame (7 and 9 Shank Models)

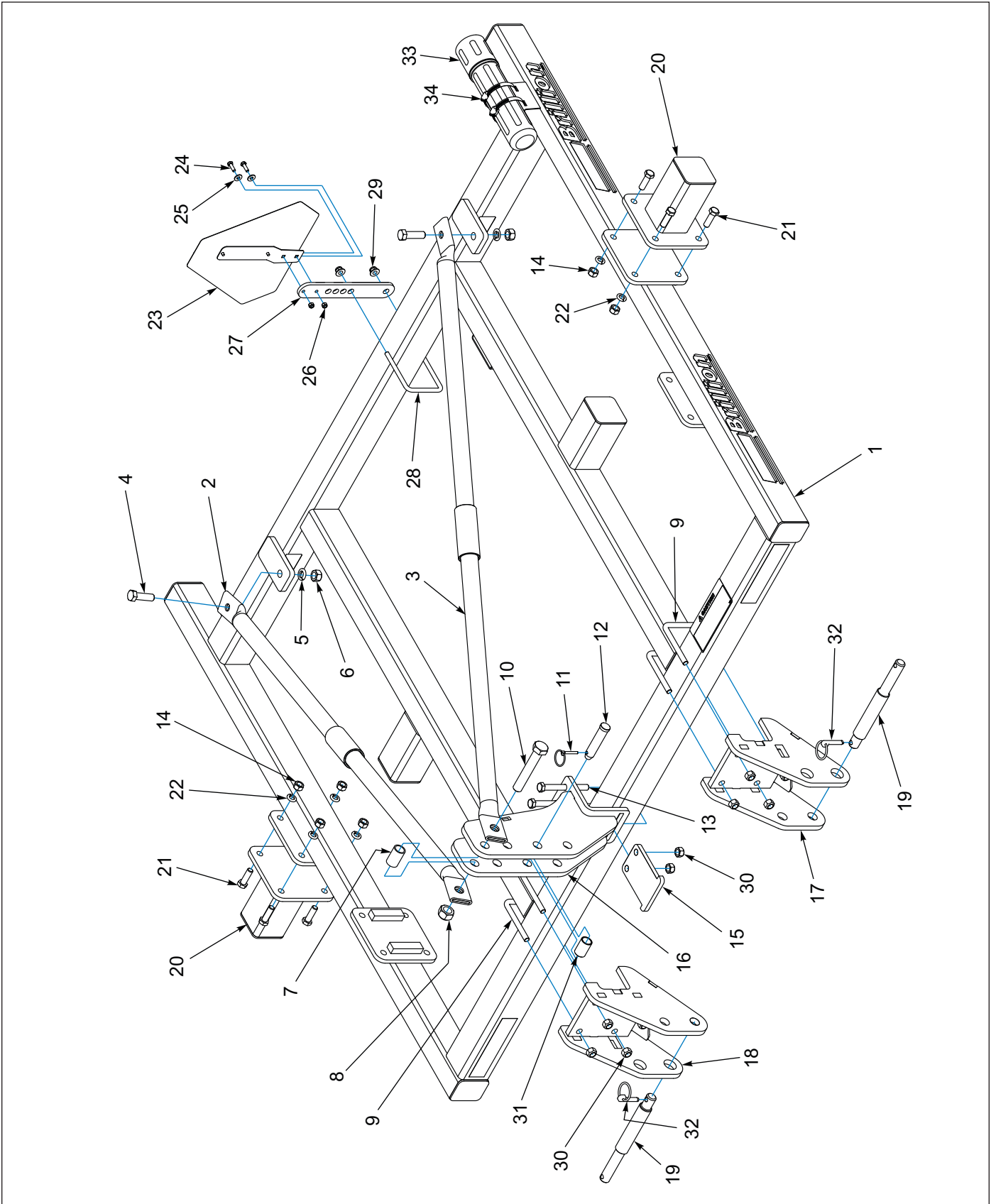

Figure 1-2: Frame (7 and 9 Shank Models)

Frame (7 and 9 Shank Models)

ITEM	PART NUMBER	DESCRIPTION	QTY
1	7D017	FRAME WELDMENT	1
2	7D472	R. H. BRACE	1
3	7D473	L. H. BRACE	1
4	1-654-010061-07	SCREW, HX CP 3/4-10UNC X 2-1/2, G5	2
5	1-861-010034-17	WASHER, LKG,HLCL SPR, 3/4	2
6	1-512-010007-12	NUT, HEX 3/4-10 GR2, ZP	2
7	6D988	SPACER	1
8	1-512-010005-19	NUT 1-8 HEX SLF-LOCKING GRB	1
9	9D989	U-BOLT, 5/8-11 X 5-5/8 X 4-11/16	4
10	1-654-10065-17	SCREW, HEX CAP, 1-8UNC X 6, GR5	1
11	1-557-010327	PIN LYNCH 1/4 X 1-1/4	1
12	6D529	CLEVIS PIN, 1.0 X 4.5	1
13	1-654-010059-17	SCREW, HX CP 5/8-11UNC X 6, GR5	2
14	1-512-010007-11	NUT, HEX 5/8-11 GR2, ZP (9' MODELS ONLY)	8
15	198951	PLATE UPPER HITCH CLAMP	1
16	198944	BRACKET WLDMT, UPPER HITCH	1
17	198938	BRACKET WLDMT, LH LOWER HITCH	1
18	198939	BRACKET WLDMT, RH LOWER HITCH	1
19	108841	PIN, LOWER 3-POINT	2
20	6D271	1 FT. EXTENSION ASSEMBLY (9' MODELS ONLY)	2
21	1-654-010059-05	SCREW, HEX CAP 5/8-11UNC X 2, GR5 (9' MODELS ONLY)	8
22	1-861-010034-15	WASHER, LKG HLCL SPR, 5/8 (9' MODELS ONLY)	8
23	2P151	SMV W/BRACKET	1
24	1-654-010049-05	SCREW, HX CP 5/16-18UNC X 1, GR5	2
25	1-861-010032-09	WASHER, FLAT 5/16 W ZP/CD	2
26	104032	NUT, HX SLF-LKG W/MYL 5/16-18	2
27	164678	MOUNT, SMV	1
28	3J562	U-BOLT 1/2-13 X 5-1/2 X 4-9/16	1
29	2P253	NUT, FLANGE NY-LOK 1/2-13	2
30	1-512-010005-13	NUT, HEX SLFLKG GRB 5/8-11	10
31	5D157	SLEEVE	1
32	2-557-010417	PIN, LYNCH CAT III	2
33	1-116-010019	MANUAL STORAGE CANISTER	1
34	105-0093	HOSE CLAMP 4-1/2 IDEAL #5264	2

Frame (10 and 12 Shank Models)

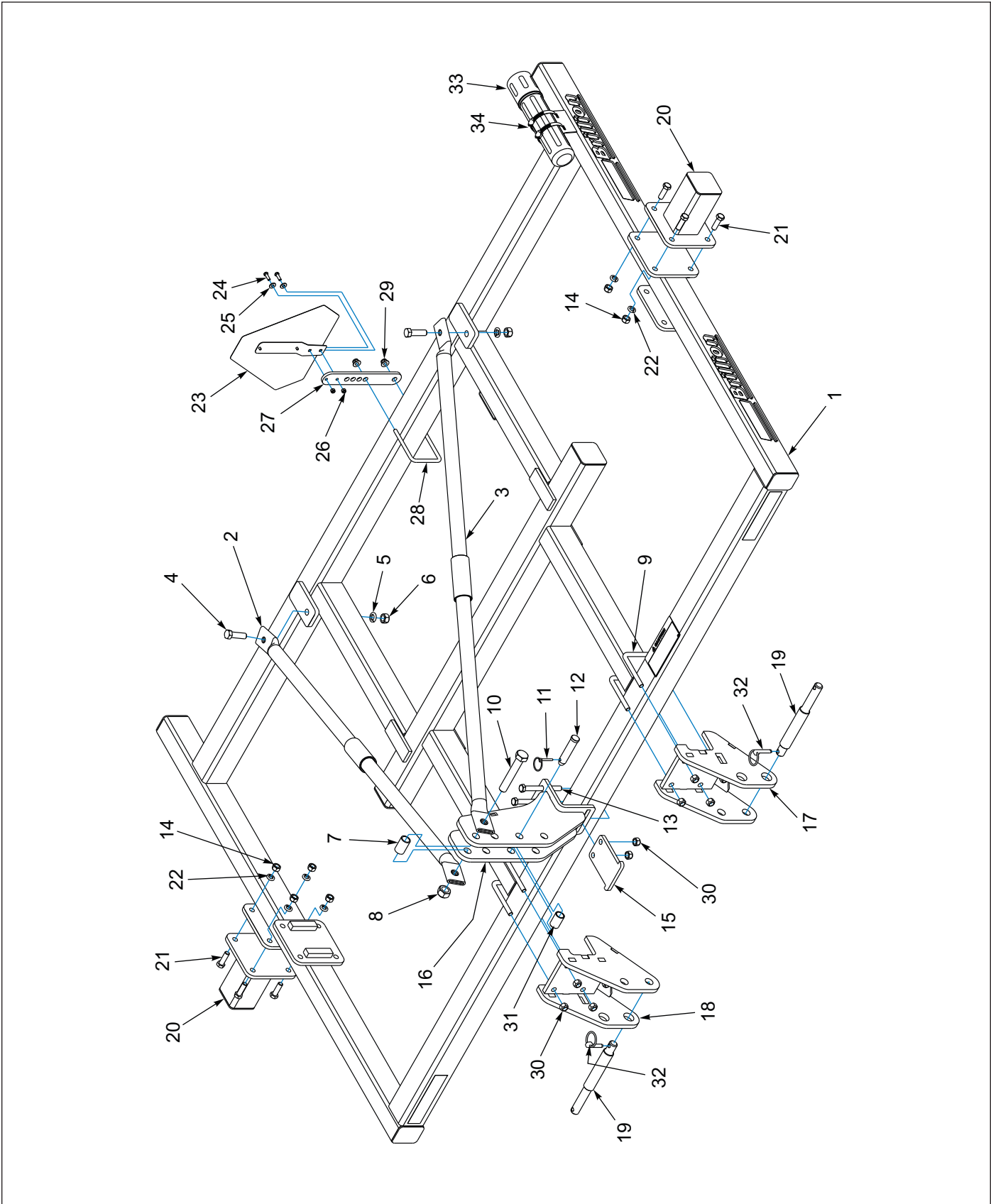

Figure 1-3: Frame (10 and 12 Shank Models)

Frame (10 and 12 Shank Models)

ITEM	PART NUMBER	DESCRIPTION	QTY
1	7D442	FRAME WELDMENT	1
2	7D472	R. H. BRACE	1
3	7D473	L. H. BRACE	1
4	1-654-010061-07	SCREW, HX CP 3/4-10UNC X 2-1/2, G5	2
5	1-861-010034-17	WASHER, LKG,HLCL SPR, 3/4	2
6	1-512-010007-12	NUT, HEX 3/4-10 GR2, ZP	2
7	6D988	SPACER	1
8	1-512-010005-19	NUT, 1-8 HEX SLF-LOCKING GRB	1
9	9D989	U-BOLT, 5/8-11 X 5-5/8 X 4-11/16	4
10	1-654-10065-17	SCREW, HEX CAP, 1-8UNC X 6, GR5	1
11	1-557-010327	PIN LYNCH 1/4 X 1-1/4	1
12	6D529	CLEVIS PIN, 1.0 X 4.5	1
13	1-654-010059-17	SCREW, HX CP 5/8-11UNC X 6, GR5	2
14	1-512-010007-11	NUT, HEX 5/8-11 GR2, ZP (12' MODELS ONLY)	8
15	198951	PLATE UPPER HITCH CLAMP	1
16	198944	BRACKET WLDMT, UPPER HITCH	1
17	198938	BRACKET WLDMT, LH LOWER HITCH	1
18	198939	BRACKET WLDMT, RH LOWER HITCH	1
19	108841	PIN, LOWER 3-POINT	2
20	6D271	1 FT. EXTENSION ASSEMBLY (12' MODELS ONLY)	2
21	1-654-010059-05	SCREW, HEX CAP 5/8-11UNC X 2, GR5 (12' MODELS ONLY)	8
22	1-861-010034-15	WASHER, LKG HLCL SPR, 5/8 (12' MODELS ONLY)	8
23	2P151	SMV W/BRACKET	1
24	1-654-010049-05	SCREW, HX CP 5/16-18UNC X 1, GR5	2
25	1-861-010032-09	WASHER, FLAT 5/16 W, ZP/CD	2
26	104032	NUT, HX SLF-LKG W/MYL 5/16-18	2
27	164678	MOUNT, SMV	1
28	3J562	U-BOLT 1/2-13 X 5-1/2 X 4-9/16	1
29	2P253	NUT, FLANGE NY-LOK 1/2-13	2
30	1-512-010005-13	NUT, HEX SLFLKG GRB 5/8-11	10
31	5D157	SLEEVE	1
32	2-557-010417	PIN, LYNCH CAT III	2
33	1-116-010019	MANUAL STORAGE CANISTER	1
34	105-0093	HOSE CLAMP 4-1/2 IDEAL #5264	2

Frame (11 Shank Model)

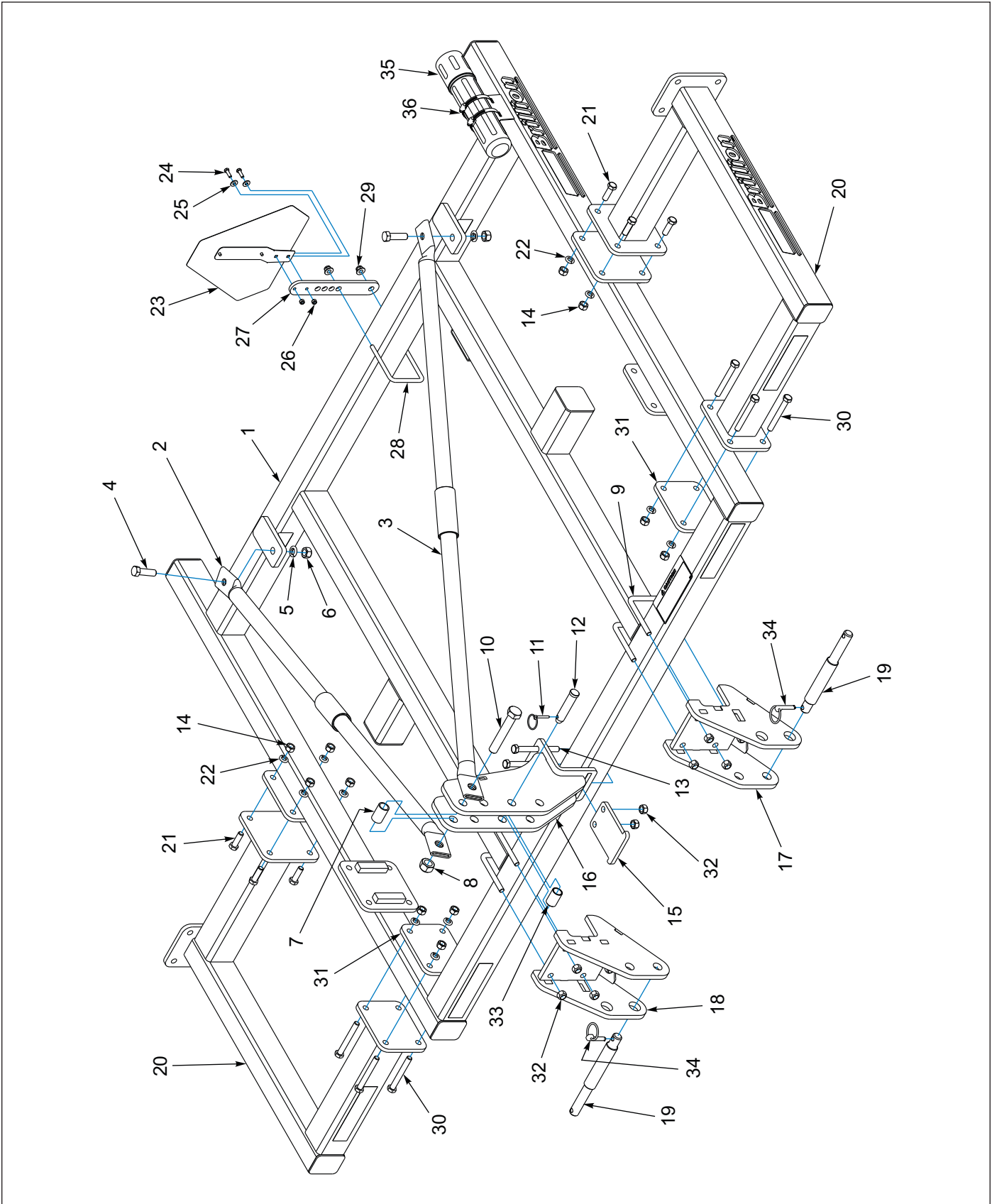

Figure 1-4: Frame (11 Shank Model)

Frame (11 Shank Model)

ITEM	PART NUMBER	DESCRIPTION	QTY
1	7D017	FRAME WELDMENT	1
2	7D472	R. H. BRACE	1
3	7D473	L. H. BRACE	1
4	1-654-010061-07	SCREW, HX CP 3/4-10UNC X 2-1/2, G5	2
5	1-861-010034-17	WASHER, LKG, HLCL SPR, 3/4	2
6	1-512-010007-12	NUT, HEX 3/4-10 GR2, ZP	2
7	6D988	SPACER	1
8	1-512-010005-19	NUT, 1-8 HEX SLF-LOCKING GRB	1
9	9D989	U-BOLT, 5/8-11 X 5-5/8 X 4-11/16	4
10	1-654-10065-17	SCREW, HEX CAP, 1-8UNC X 6, GR5	1
11	1-557-010327	PIN LYNCH 1/4 X 1-1/4	1
12	6D529	CLEVIS PIN, 1.0 X 4.5	1
13	1-654-010059-17	SCREW, HX CP 5/8-11UNC X 6, GR5	2
14	1-512-010007-11	NUT, HEX 5/8-11 GR2, ZP	16
15	198951	PLATE UPPER HITCH CLAMP	1
16	198944	BRACKET WLDMT, UPPER HITCH	1
17	198938	BRACKET WLDMT, LH LOWER HITCH	1
18	198939	BRACKET WLDMT, RH LOWER HITCH	1
19	108841	PIN, LOWER 3-POINT	2
20	6D273	2 FT. EXTENSION ASSEMBLY	2
21	1-654-010059-05	SCREW, HEX CAP 5/8-11UNC X 2, GR5	8
22	1-861-010034-15	WASHER, LKG HLCL SPR, 5/8	16
23	2P151	SMV W/BRACKET	1
24	1-654-010049-05	SCREW, HX CP 5/16-18UNC X 1, GR5	2
25	1-861-010032-09	WASHER, FLAT 5/16 W, ZP/CD	2
26	104032	NUT, HX SLF-LKG W/MYL 5/16-18	2
27	164678	MOUNT, SMV	1
28	3J562	U-BOLT 1/2-13 X 5-1/2 X 4-9/16	1
29	2P253	NUT, FLANGE NY-LOK 1/2-13	2
30	1-654-010059-15	SCREW, HEX CAP 5/8-11UNC X 5, GR5	8
31	6D299	PLATE	2
32	1-512-010005-13	NUT, HEX SLFLKG GRB 5/8-11	10
33	5D157	SLEEVE	1
34	2-557-010417	PIN, LYNCH CAT III	2
35	1-116-010019	MANUAL STORAGE CANISTER	1
36	105-0093	HOSE CLAMP 4-1/2 IDEAL #5264	2

Shank and Spring Clamp Assembly

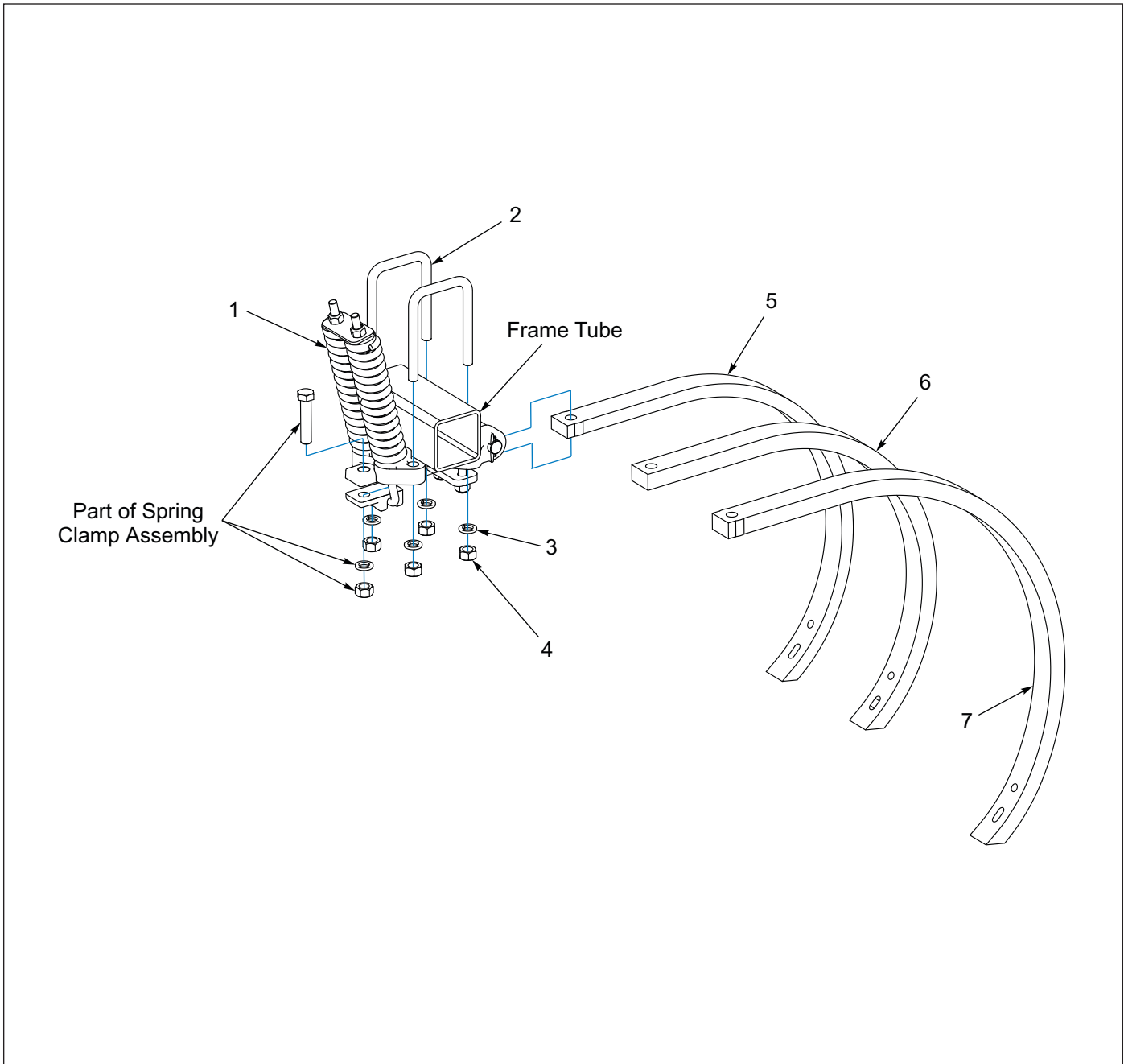

Figure 1-5: Shank and Spring Clamp Assembly

Shank and Spring Clamp Assembly

ITEM	PART NUMBER	DESCRIPTION	QTY
1	4J681	SPRING CLAMP ASM (SEE FIGURE 1-6)	1
2	4J293	U-BOLT, 3/4-10 X 6-3/8 X 4-3/4	2
3	1-861-010034-17	WASHER, LKG, HLCL, SPR, 3/4	4
4	1-512-010007-12	NUT, HEX 3/4-10 GR2, ZP	4
5	6D283	SHANK - 26S	1
6	2J644	SHANK	1
7	6D913	SHANK 32T	1

Spring Shank Assembly

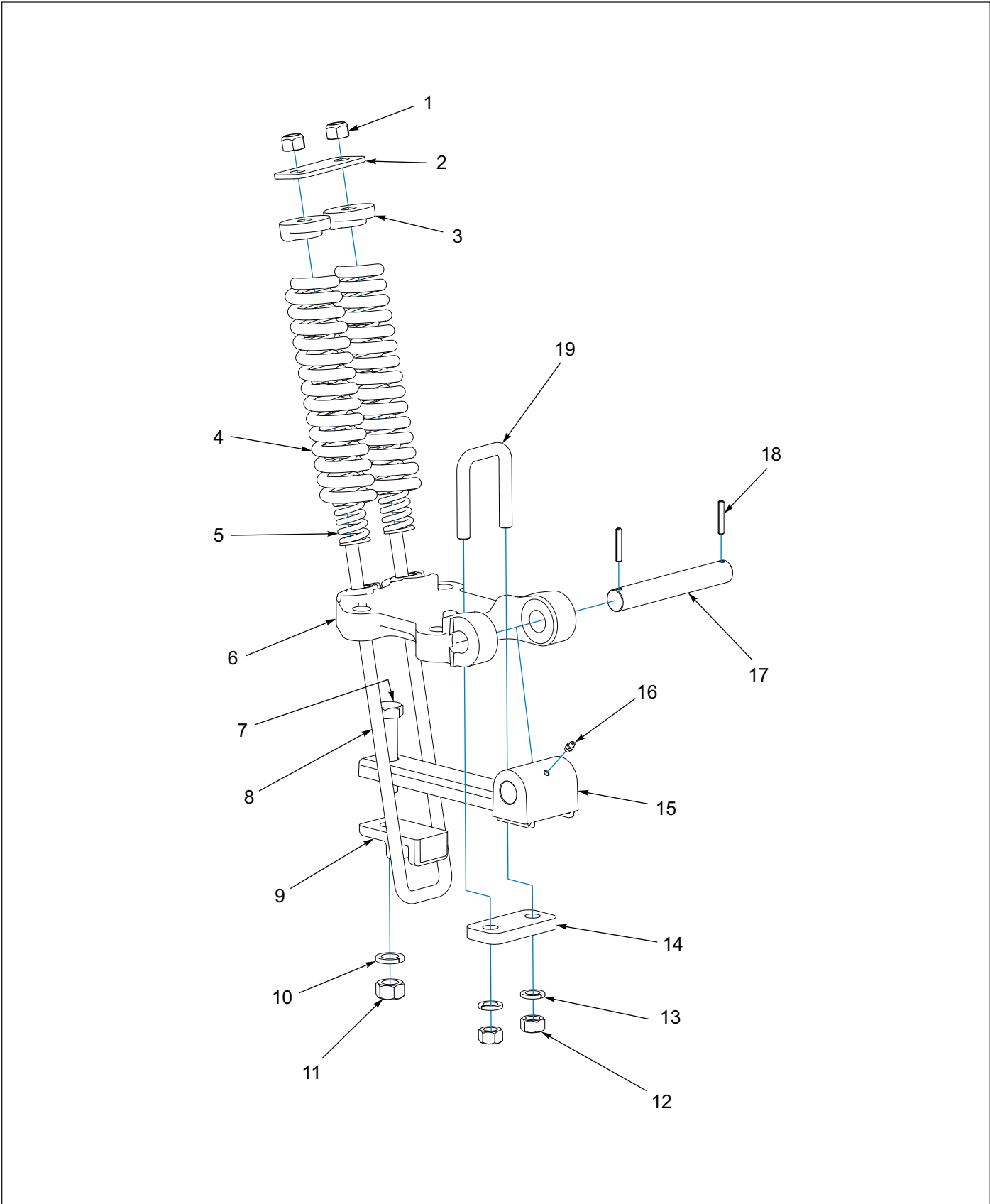

Figure 1-6: Spring Shank Assembly

Spring Shank Assembly

ITEM	PART NUMBER	DESCRIPTION	QTY
	4J681	SPRING CLAMP ASM	1
1	1-512-010005-13	NUT, HEX, SLFLKG GRB 5/8-11	2
2	6D409	STRAP	1
3	6J459	CAP	2
4	4K076	COMPRESSION SPRING - OUTER	2
5	6D362	COMPRESSION SPRING - INNER	2
6	4J675	SHANK CLAMP	1
7	141776	SCREW, HXCP 3/4-10UNC X 3-1/2, GR5	1
8	2J096	U-BOLT, 5/8-11 X 16 X 2-3/4, ZP	1
9	2J091	U-BOLT, CLIP	1
10	1-861-010034-17	WASHER, LKG, HLCL SPR, 3/4	1
11	1-512-010007-12	NUT, HEX 3/4-10 GR2, ZP	1
12	1-512-010007-11	NUT, HEX 5/8-11 GR2, ZP	2
13	1-861-010034-15	WASHER, LKG HLCL SPR, 5/8	2
14	6D280	STRAP	1
15	2J092	SHANK HOLDER	1
16	1-298-010001-1	ZERK FITTING 1/4 SAE	1
17	8J130	PIN, 1.0 X 6.875 PLATED	1
18	1-647-010004217	ROLL PIN 1/4 X 1-1/2	2
19	2J094	U-BOLT, 5/8-11 X 3-3/8 X 2-5/8	1

ILLUSTRATED PARTS LIST

Rigid Shank Assembly

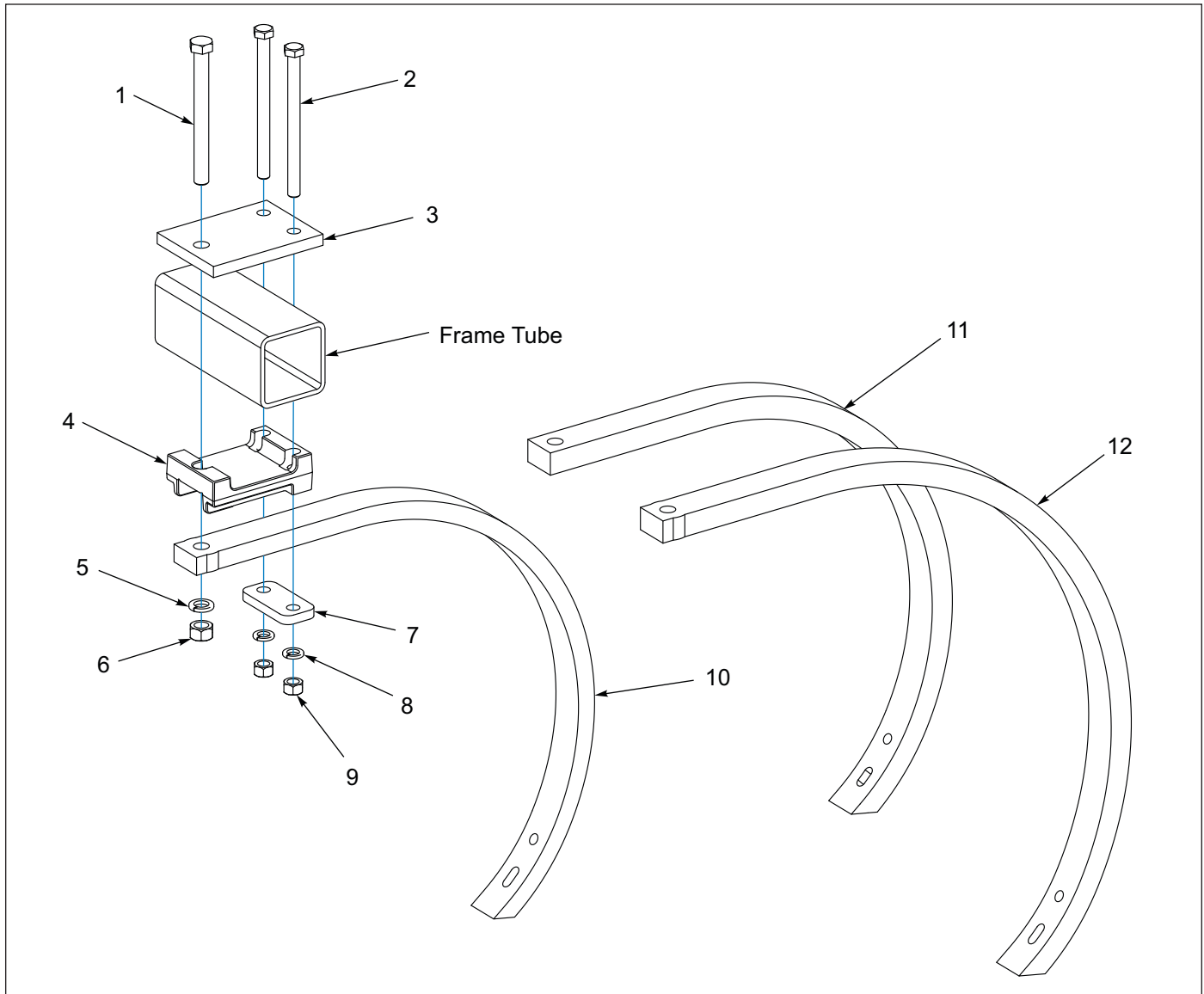

Figure 1-7: Rigid Shank Assembly

Rigid Shank Assembly

ITEM	PART NUMBER	DESCRIPTION	QTY
1	1-654-010061-20	SCREW, HX CP 3/4-10UNC X 7-1/2, G5	1
2	1-654-010059-21	SCREW, HEX CAP 5/8-11UNC X 8, GR5	2
3	6D298	PLATE	1
4	6D234	SHANK SUPPORT	1
5	1-861-010034-17	WASHER, LKG HLCL SPR, 3/4	1
6	1-512-010007-12	NUT, HEX 3/4-10	1
7	6D280	STRAP	1
8	1-861-010034-15	WASHER, LKG,HLCL SPR, 5/8	2
9	1-512-010007-13	NUT, HEX 5/8-11	2
10	6D283	SHANK - 26S	1
11	2J644	SHANK	1
12	6D913	SHANK 32T	1

Points

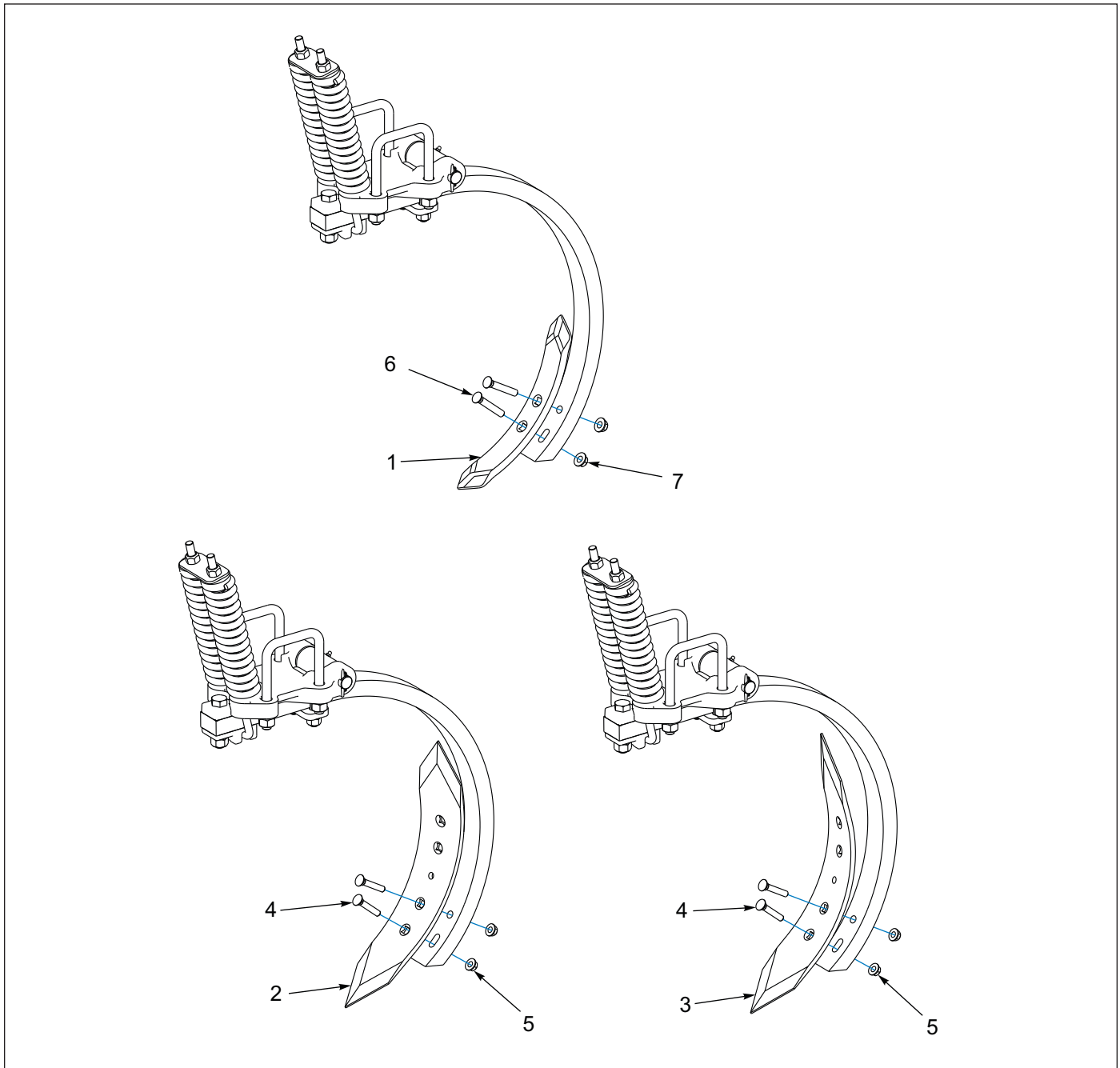

Figure 1-8: Points

Points

ITEM	PART NUMBER	DESCRIPTION	QTY
1	6D213	CHISEL POINT	1
2	6D216	REV. DBL.PT. TW SHOVEL (LEFT)	1
3	6D215	REV. DBL.PT. TW SHOVEL (RIGHT)	1
4	7K964	SPECIAL PLOW BOLT	2
5	4K551	SELF-LOCKING FLANGE NUT (7/16-14)	2
6	1/2-13X3PLOW	PLOW BOLT GR5	2
7	4K552	SELF-LOCKING FLANGENUT (1/2-13)	2

LED Warning Lights (7 and 9 Shank Models)

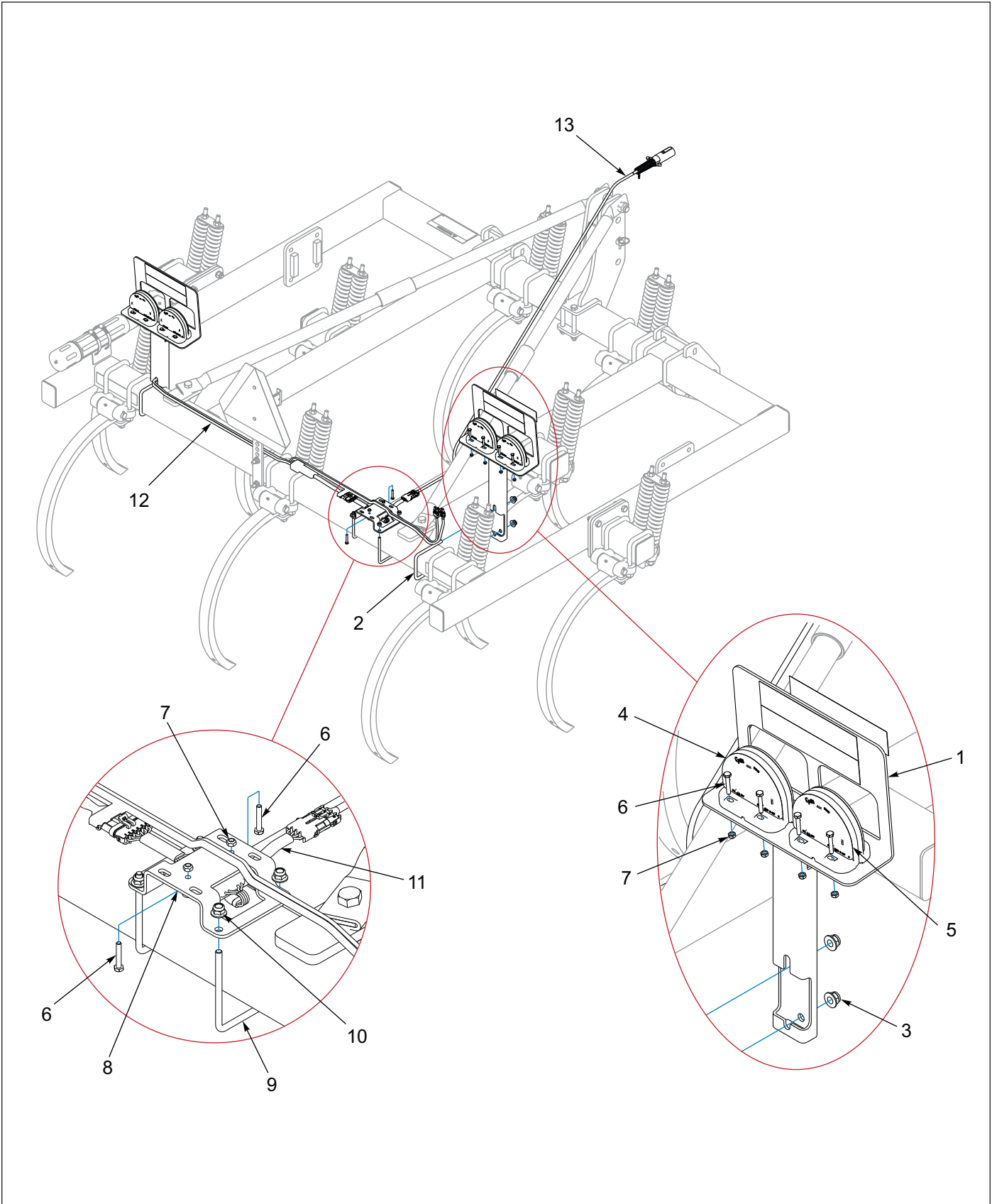

Figure 1-9: LED Warning Lights (7 and 9 Shank Models)

LED Warning Lights (7 and 9 Shank Models)

ITEM	PART NUMBER	DESCRIPTION	QTY
1	178554	BRACKET WLDMT, LIGHT	2
2	3J562	U-BOLT, 1/2-13 X 5-1/2 X 4	2
3	2P253	NUT, FLANGE NY-LOK 1/2-13	4
4	174436	LAMP, AG AMBER SINGLE LED	2
5	174435	LAMP, AG RED SINGLE LED	2
6	1-654-010047-08	SCREW HX CP, 1/4-20UNC X 1-1/2, G5	18
7	1-512-010005-01	NUT, HEX, SLFLKG GRB 1/4-20	18
8	178506	BRACKET, MODULE MOUNT	1
9	178507	U-BOLT, 3/8-16 X 4-3/8 X 5, ZP	2
10	2P252	NUT, FLANGE NY-LOK 3/8-16	4
11	174437	MODULE, AG FLASHER CONTROL	1
12	178525	HARNESS, LAMP 84 X 84	1
13	178514	HARNESS, 7 PIN/4PIN WP, 10'	1

LED Warning Lights (10 and 12 Shank Models)

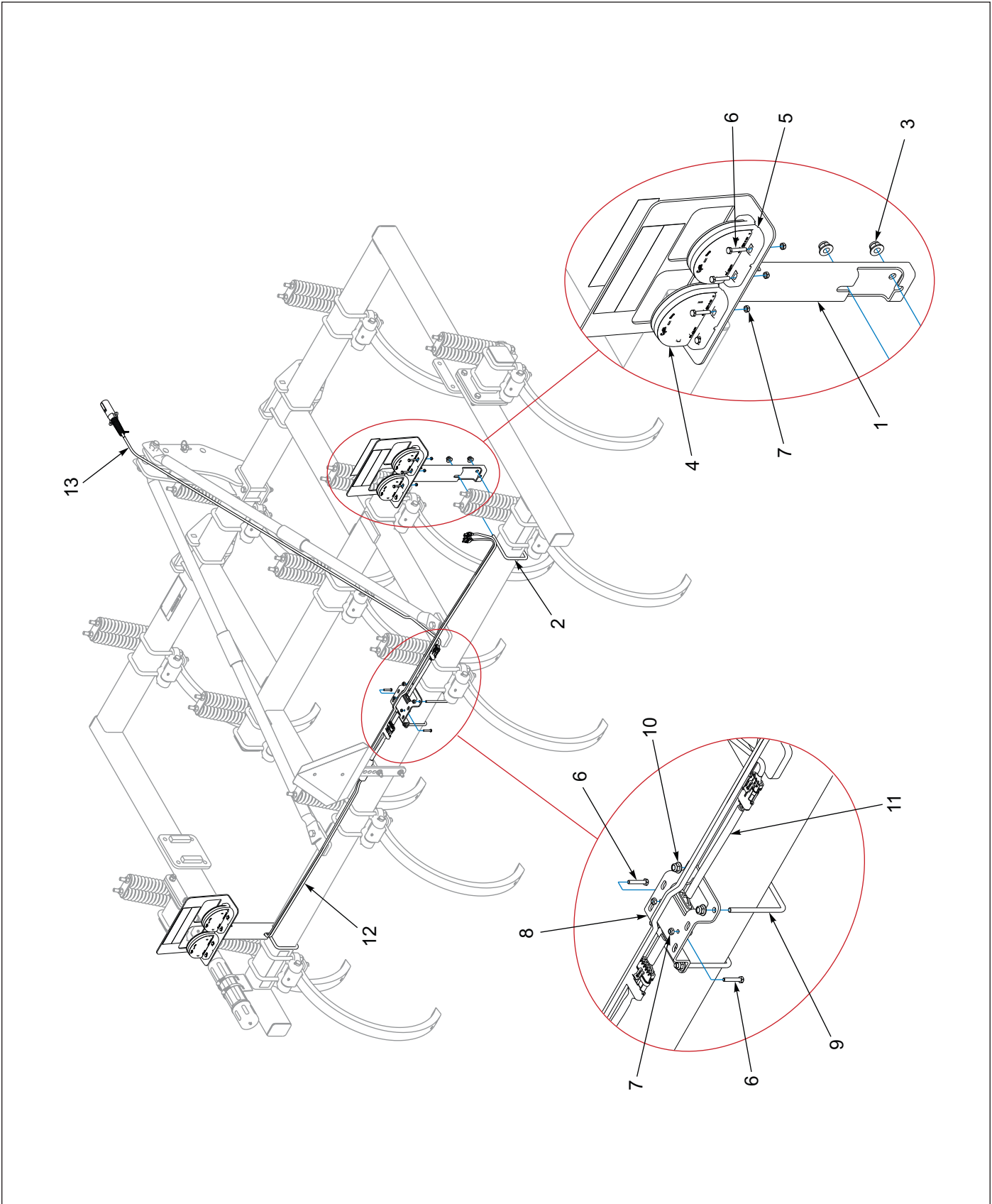

Figure 1-10: LED Warning Lights (10 and 12 Shank Models)

LED Warning Lights (10 and 12 Shank Models)

ITEM	PART NUMBER	DESCRIPTION	QTY
1	178554	BRACKET WLDMT, LIGHT	2
2	3J562	U-BOLT, 1/2-13 X 5-1/2 X 4	2
3	2P253	NUT, FLANGE NY-LOK 1/2-13	4
4	174436	LAMP, AG AMBER SINGLE LED	2
5	174435	LAMP, AG RED SINGLE LED	2
6	1-654-010047-08	SCREW, HX CP, 1/4-20UNC X 1-1/2, G5	18
7	1-512-010005-01	NUT, HEX,SLFLKG GRB 1/4-20	18
8	178506	BRACKET, MODULE MOUNT	1
9	178507	U-BOLT, 3/8-16 X 4-3/8 X 5, ZP	2
10	2P252	NUT, FLANGE NY-LOK 3/8-16	4
11	174437	MODULE, AG FLASHER CONTROL	1
12	178525	HARNESS, LAMP 84 X 84	1
13	178514	HARNESS, 7 PIN/4PIN WP, 10'	1

LED Warning Lights (11 Shank Model)

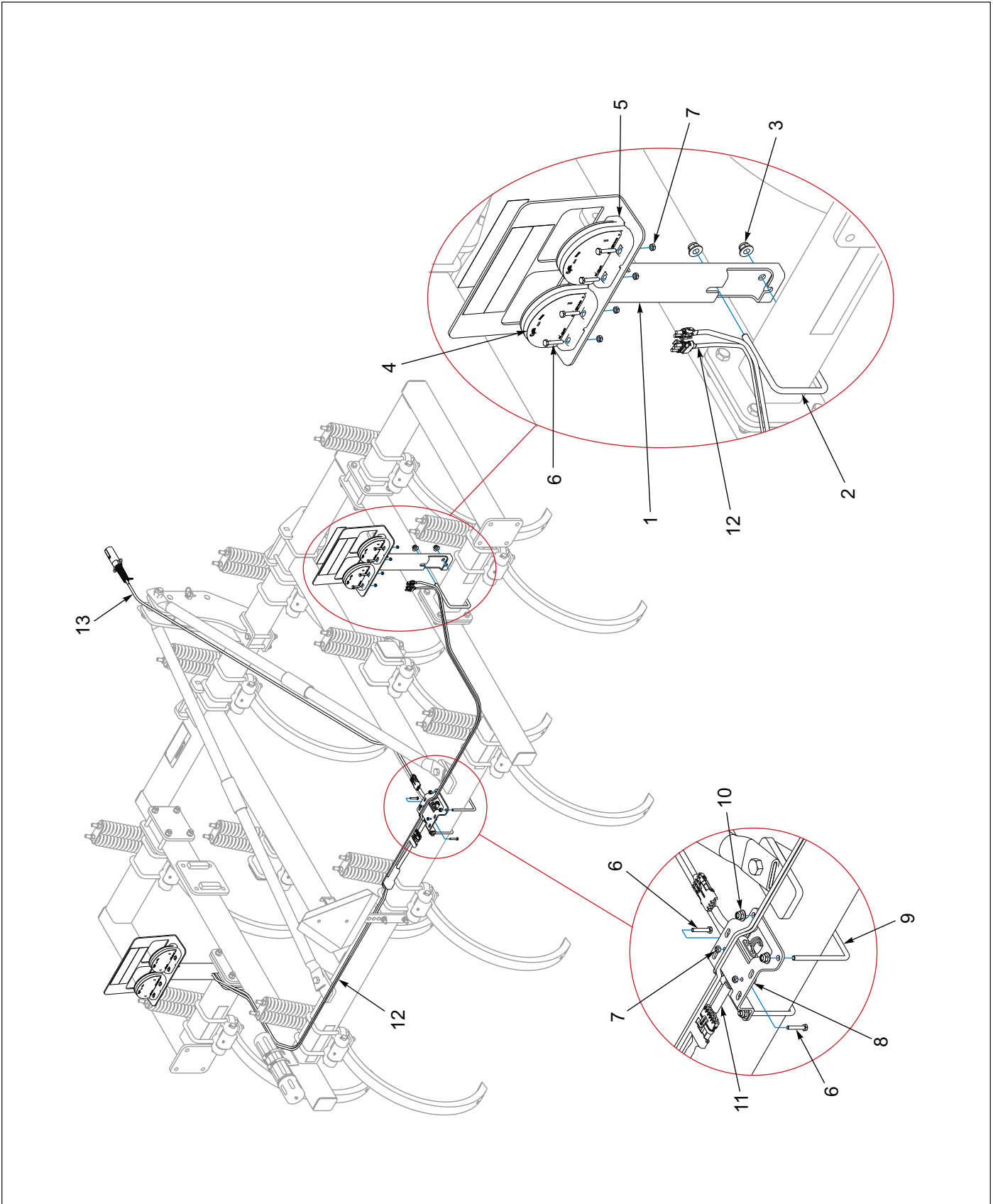

Figure 1-11: LED Warning Lights (11 Shank Model)

LED Warning Lights (11 Shank Model)

ITEM	PART NUMBER	DESCRIPTION	QTY
1	178554	BRACKET WLDMT, LIGHT	2
2	3J562	U-BOLT, 1/2-13 X 5-1/2 X 4	2
3	2P253	NUT, FLANGE NY-LOK 1/2-13	4
4	174436	LAMP, AG AMBER SINGLE LED	2
5	174435	LAMP, AG RED SINGLE LED	2
6	1-654-010047-08	SCREW HX CP, 1/4-20UNC X 1-1/2, G5	18
7	1-512-010005-01	NUT, HEX, SLFLKG GRB 1/4-20	18
8	178506	BRACKET, MODULE MOUNT	1
9	178507	U-BOLT, 3/8-16 X 4-3/8 X 5, ZP	2
10	2P252	NUT, FLANGE NY-LOK 3/8-16	4
11	174437	MODULE, AG FLASHER CONTROL	1
12	178525	HARNESS, LAMP 84 X 84	1
13	178514	HARNESS, 7 PIN/4PIN WP, 10'	1

Extension Kit, 2FT - Optional

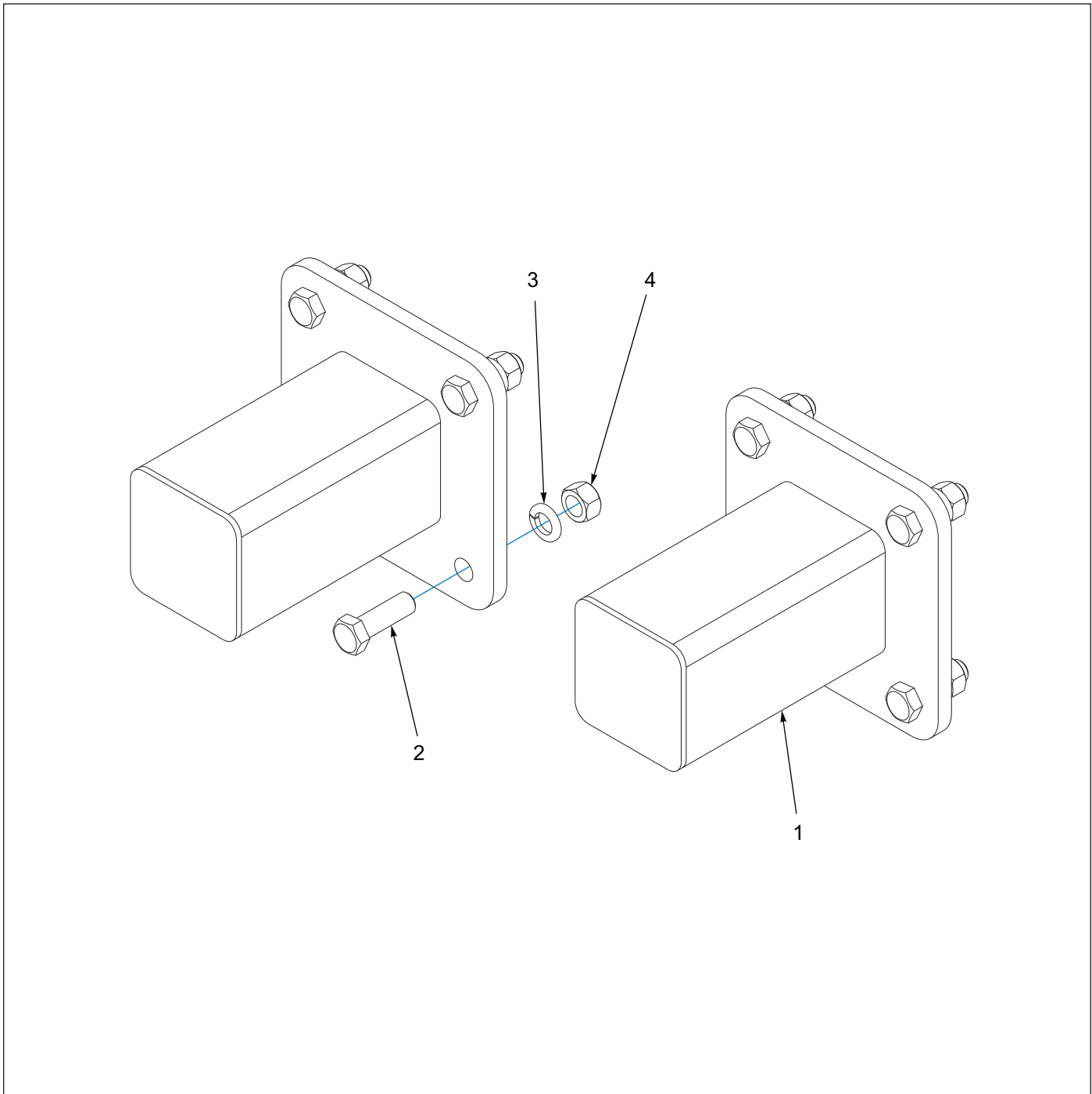

Figure 1-12: Extension Kit, 2FT - Optional

Extension Kit, 2FT - Optional

ITEM	PART NUMBER	DESCRIPTION	QTY
	6D226	KIT, 2 FT EXTENSION	1
1	6D271	1 FT. EXTENSION ASSEMBLY	2
2	1-654-010059-05	SCREW, HEX CAP, 5/8-11UNC X 2, GR5	8
3	1-861-010034-15	WASHER, LKG,HLCL SPR, 5/8	8
4	1-512-010007-11	NUT, HEX 5/8-11 GR2, ZP	8

Extension Kit, 4FT - Optional

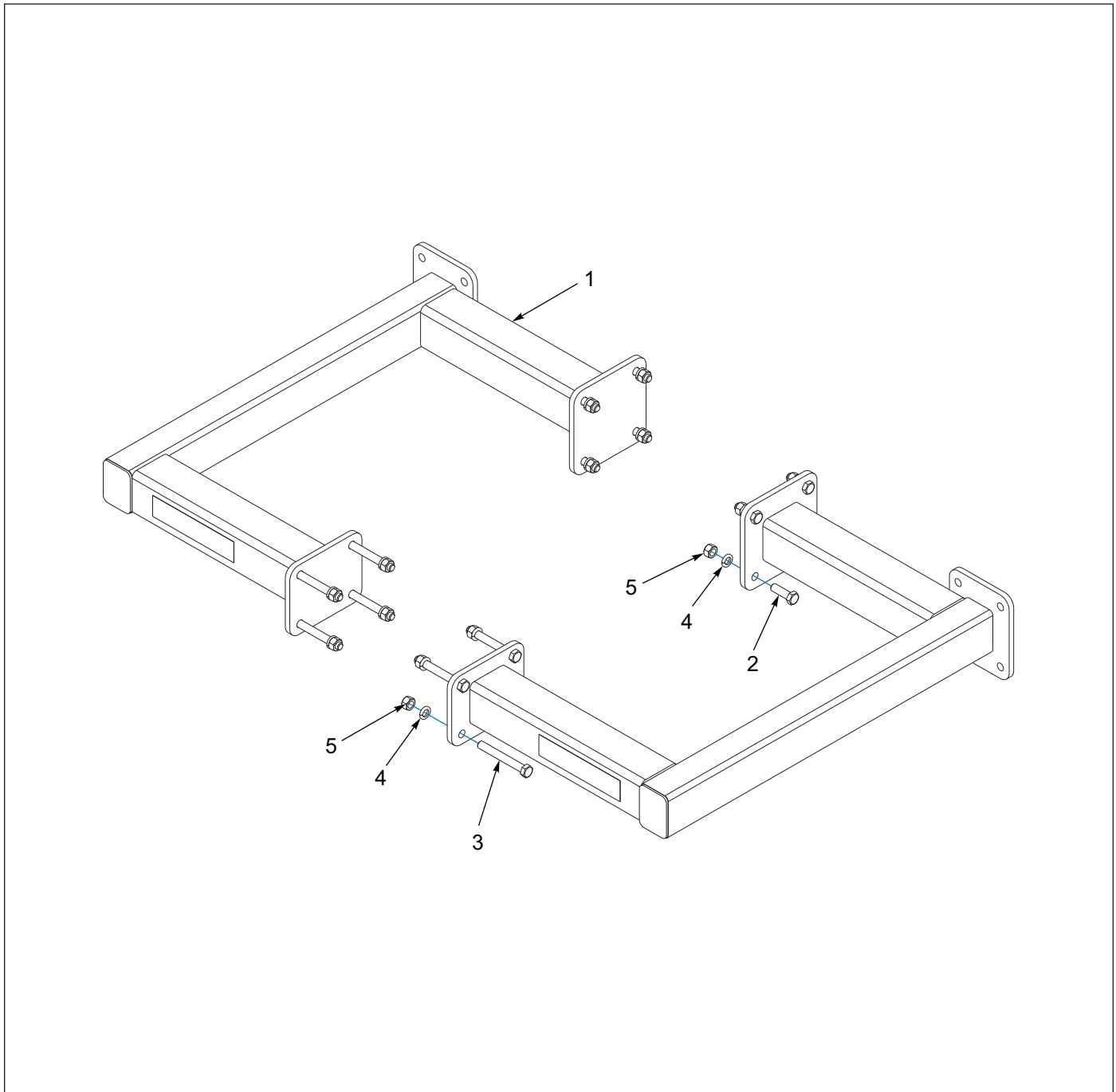

Figure 1-13: Extension Kit, 4FT - Optional

Extension Kit, 4FT - Optional

ITEM	PART NUMBER	DESCRIPTION	QTY
	6D227	KIT, 4FT EXTENSION	1
1	6D273	2 FT. EXTENSION ASSEMBLY	2
2	1-654-010059-05	SCREW, HEX CAP, 5/8-11UNC X 2, GR5	8
3	1-654-010059-15	SCREW, HEX CAP, 5/8-11UNC X 5, GR5	8
4	1-861-010034-15	WASHER, LKG,HLCL SPR,5/8	16
5	1-512-010007-11	NUT, HEX 5/8-11 GR2, ZP	16

Bracket Assemblies - Optional (Before 04/2016)

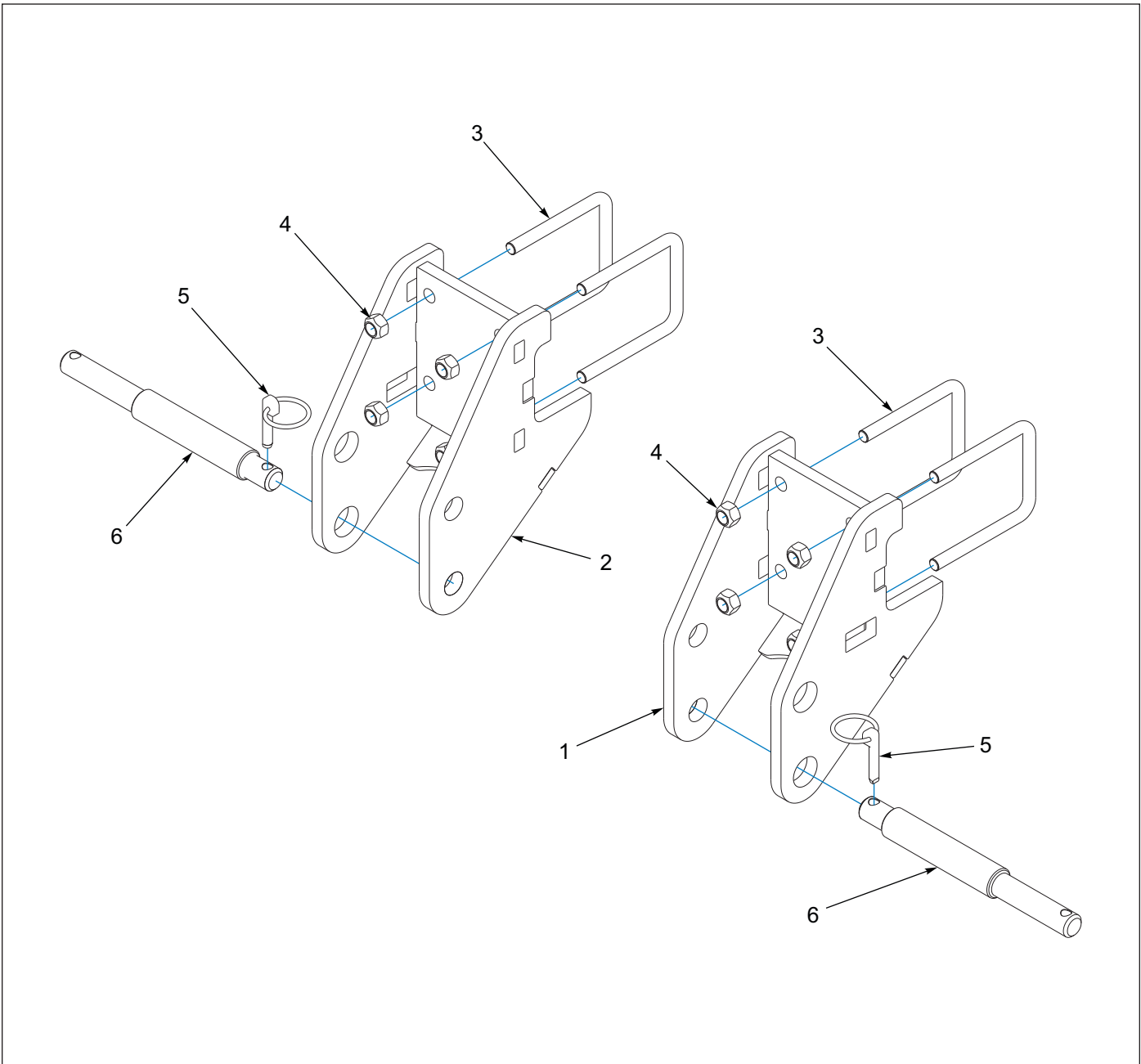

Figure 1-14: Bracket Assemblies - Optional (Before 04/2016)

Bracket Assemblies - Optional (Before 04/2016)

ITEM	PART NUMBER	DESCRIPTION	QTY
	198946	BRACKET ASM, LH LOWER HITCH (INCLUDES ITEMS 1, 3-6)	1
	198947	BRACKET ASM, RH LOWER HITCH (INCLUDES ITEMS 2-6)	1
1	198938	BRACKET WLDMT, LH LOWER HITCH	1
2	198939	BRACKET WLDMT, RH LOWER HITCH	1
3	9D989	U-BLT, 5/8-11 X 4-11/16 X 5-5/8, ZP	4
4	1-512-010005-13	NUT, HEX SLFLKG GRB 5/8-11	8
5	2-557-010417	PIN, LYNCH CAT 3	2
6	108841	PIN, LOWER, 3-POINT	2

Gauge Wheel Kit, 32" - Optional

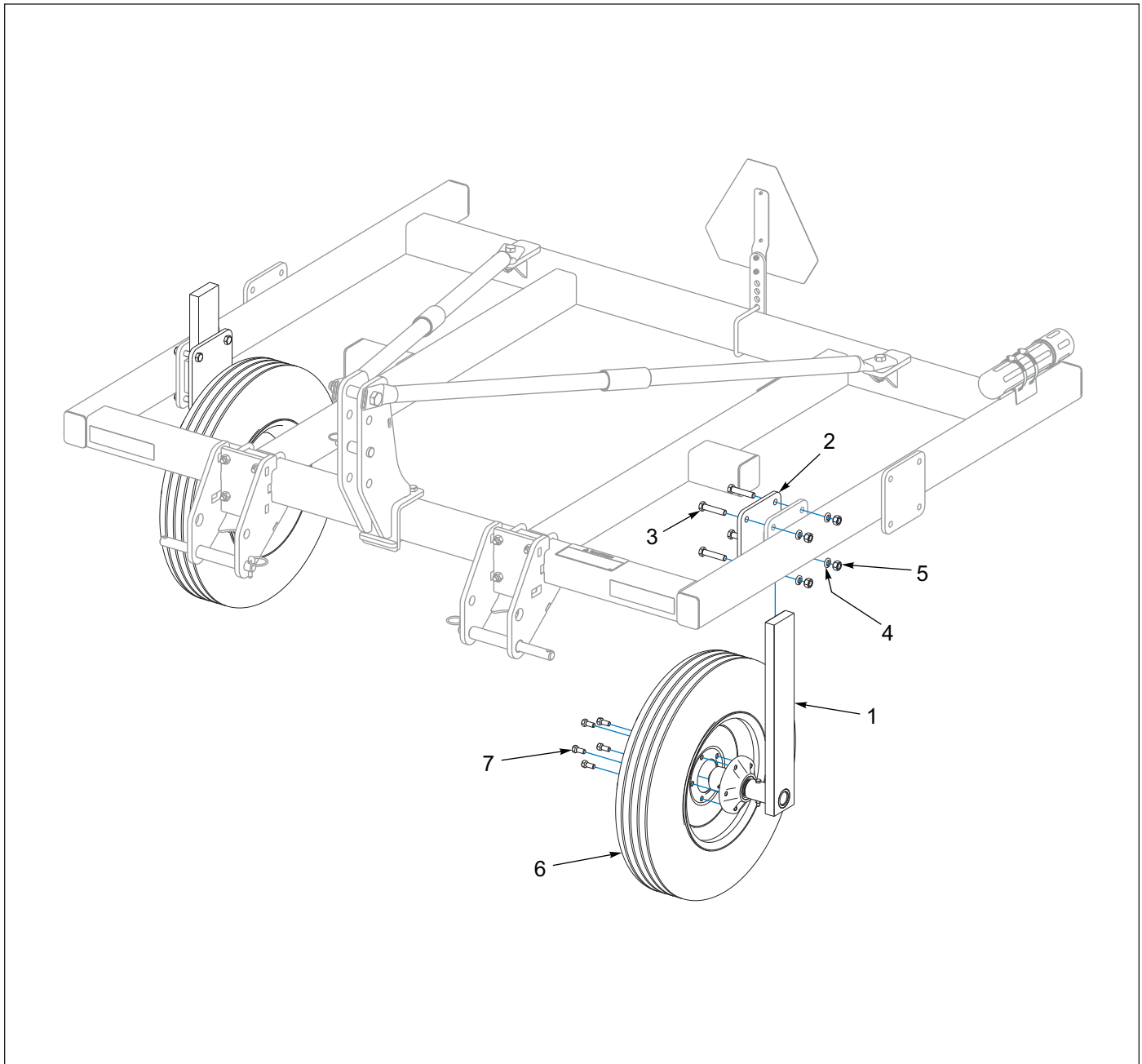

Figure 1-15: Gauge Wheel Kit, 32" - Optional

Gauge Wheel Kit, 32" - Optional

ITEM	PART NUMBER	DESCRIPTION	QTY
	6D946	32" GAUGE WHEEL KIT	1
1	1J402	HUB & BAR ASSEMBLY (SEE FIGURE 1-17)	2
2	1J469	PLATE	2
3	1-654-010059-09	SCREW, 5/8-11UNC X 3 HX CP, GR5	8
4	1-861-010034-15	WASHER, LKG,HLCL SPR, 5/8	8
5	1-512-010007-11	NUT, HEX 5/8-11 GR2, ZP	8
6	6K911	WHEEL 8J789/NO TUBE/4C129 (SEE FIGURE 1-20)	2
7	5C100	WHEEL BOLT 1/2-20 X 1 GR5, ZP	10

Gauge Wheel Kit, 26" - Optional

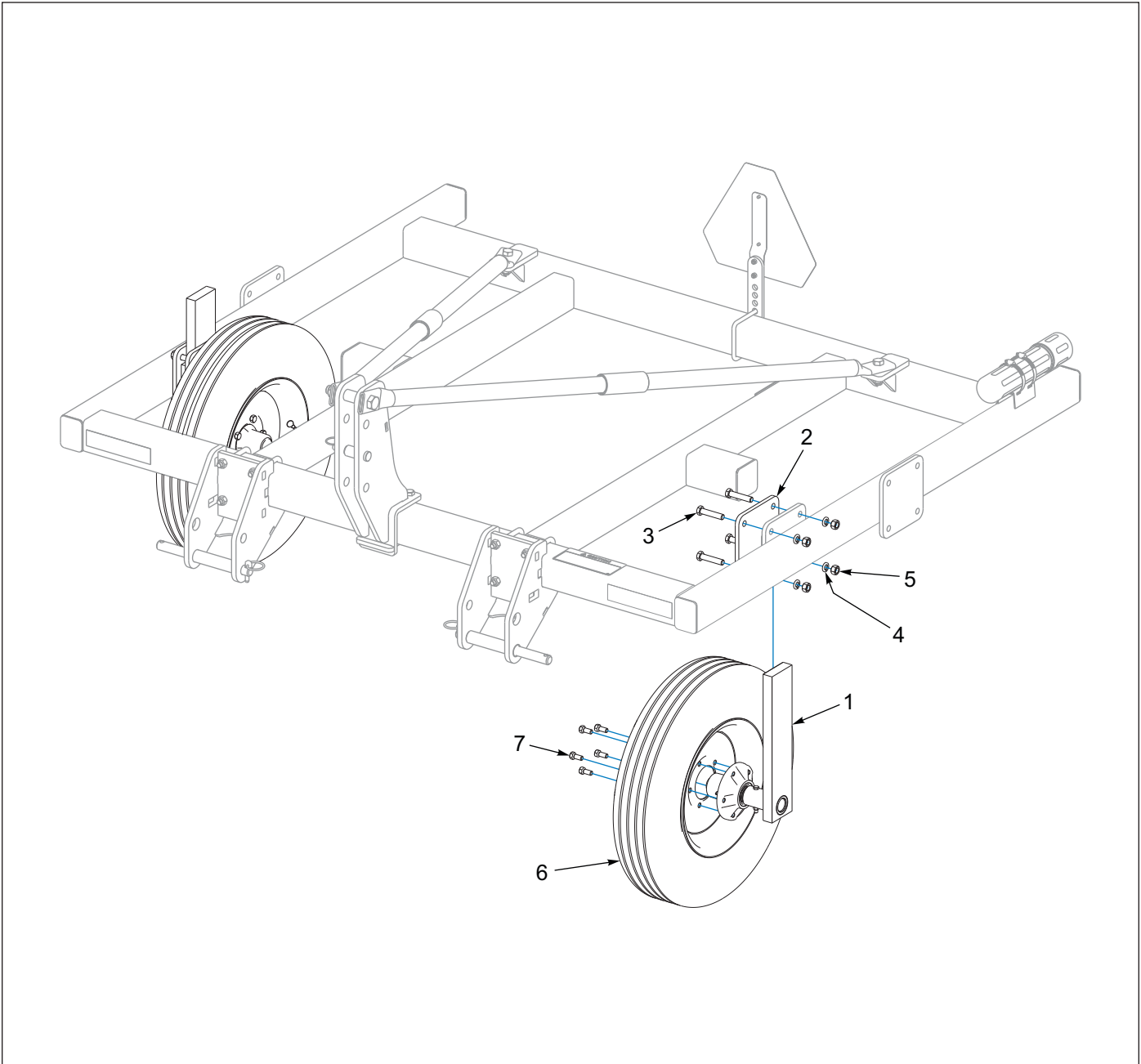

Figure 1-16: Gauge Wheel Kit, 26" - Optional

Gauge Wheel Kit, 26" - Optional

ITEM	PART NUMBER	DESCRIPTION	QTY
	7D441	26" GAUGE WHEEL KIT	1
1	1J404	HUB & BAR ASSEMBLY (SEE FIGURE 1-18)	2
2	1J469	PLATE	2
3	1-654-010059-09	SCREW, 5/8-11UNC X 3 HX CP, GR5	8
4	1-861-010034-15	WASHER, LKG,HLCL SPR, 5/8	8
5	1-512-010007-11	NUT, HEX 5/8-11 GR2, ZP	8
6	6K911	WHEEL 8J789/NO TUBE/4C129 (SEE FIGURE 1-20)	2
7	5C100	WHEEL BOLT 1/2-20 X 1 GR5, ZP	10

Hub and Bar Assembly, 1J402

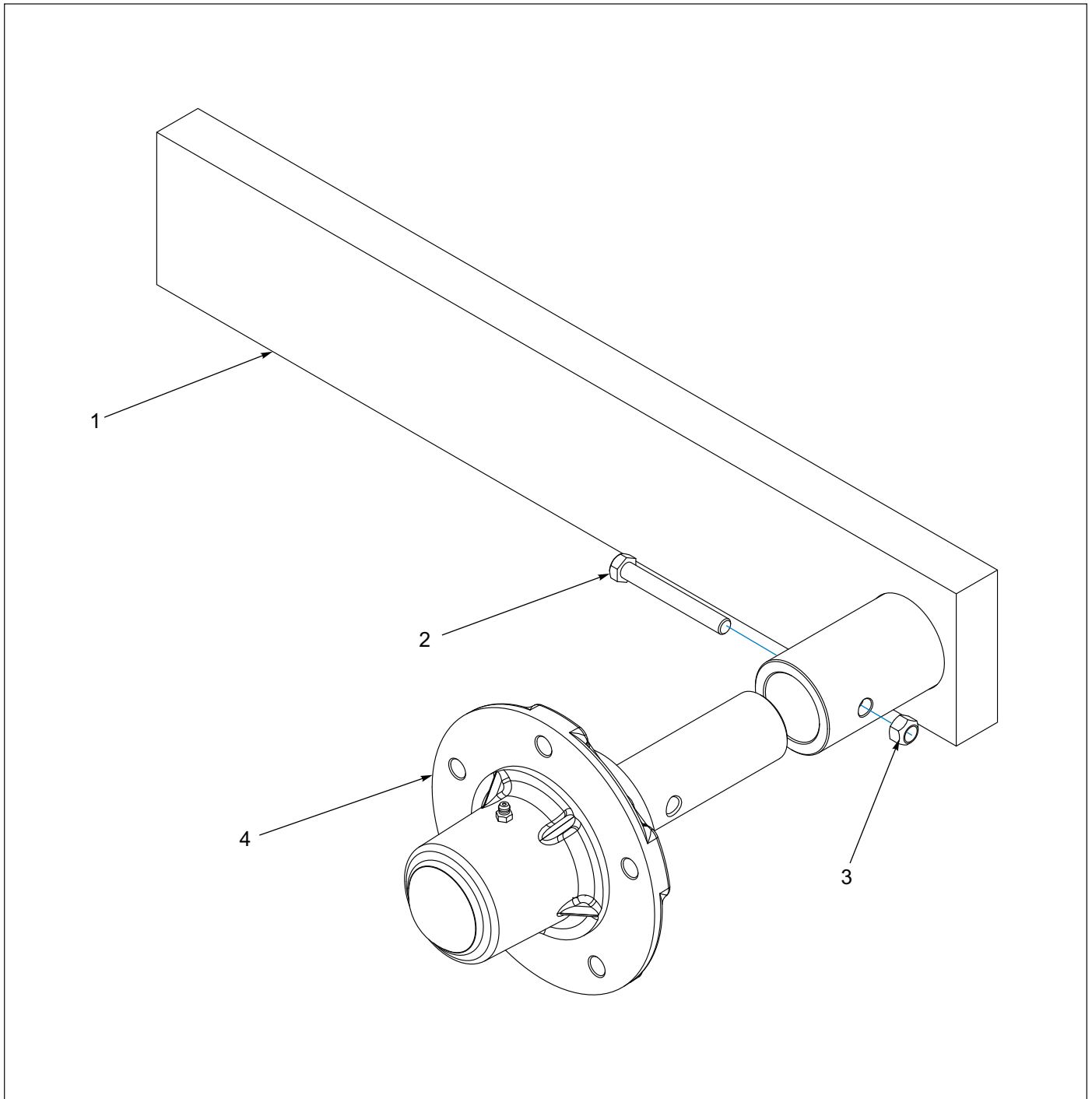

Figure 1-17: Hub and Bar Assembly, 1J402

Hub and Bar Assembly, 1J402

ITEM	PART NUMBER	DESCRIPTION	QTY
	1J402	HUB & BAR ASSEMBLY	1
1	168344	ARM WELDMENT	1
2	1-654-010051-13	SCREW, HX CP, 3/8-16UNC X 3, GR5	1
3	1-512-010005-05	NUT, HEX, SLFLKG GRB 3/8-16	1
4	1J398	HUB & SPINDLE ASSEMBLY (SEE FIGURE 1-19)	1

Hub and Bar Assembly, 1J404

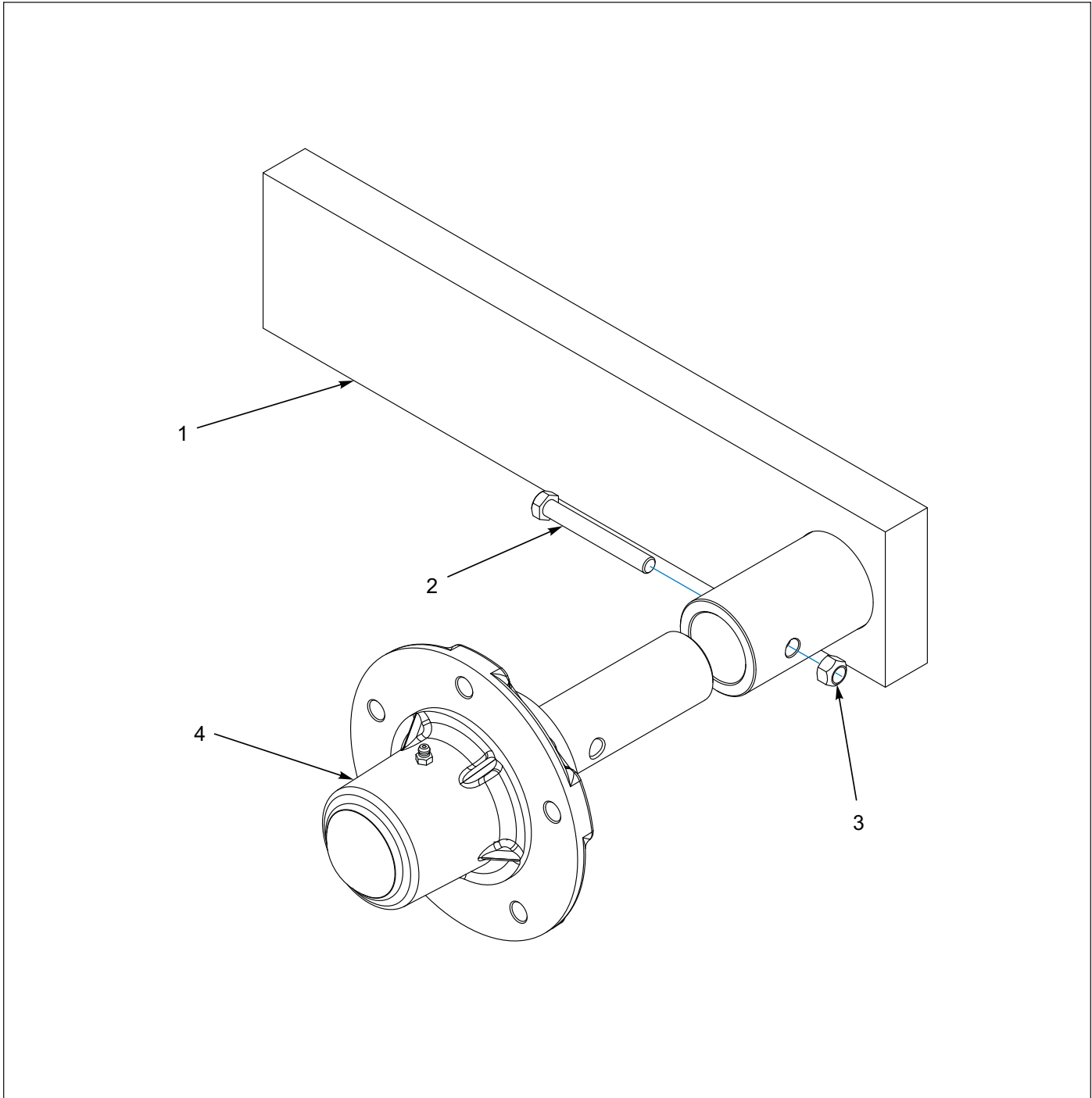

Figure 1-18: Hub and Bar Assembly, 1J404

Hub and Bar Assembly, 1J404

ITEM	PART NUMBER	DESCRIPTION	QTY
	1J404	HUB & BAR ASSEMBLY	1
1	168345	ARM WELDMENT	1
2	1-654-010051-13	SCREW, HX CP, 3/8-16UNC X 3, GR5	1
3	1-512-010005-05	NUT, HEX, SLFLKG GRB 3/8-16	1
4	1J398	HUB & SPINDLE ASSEMBLY (SEE FIGURE 1-19)	1

Hub and Spindle Assembly

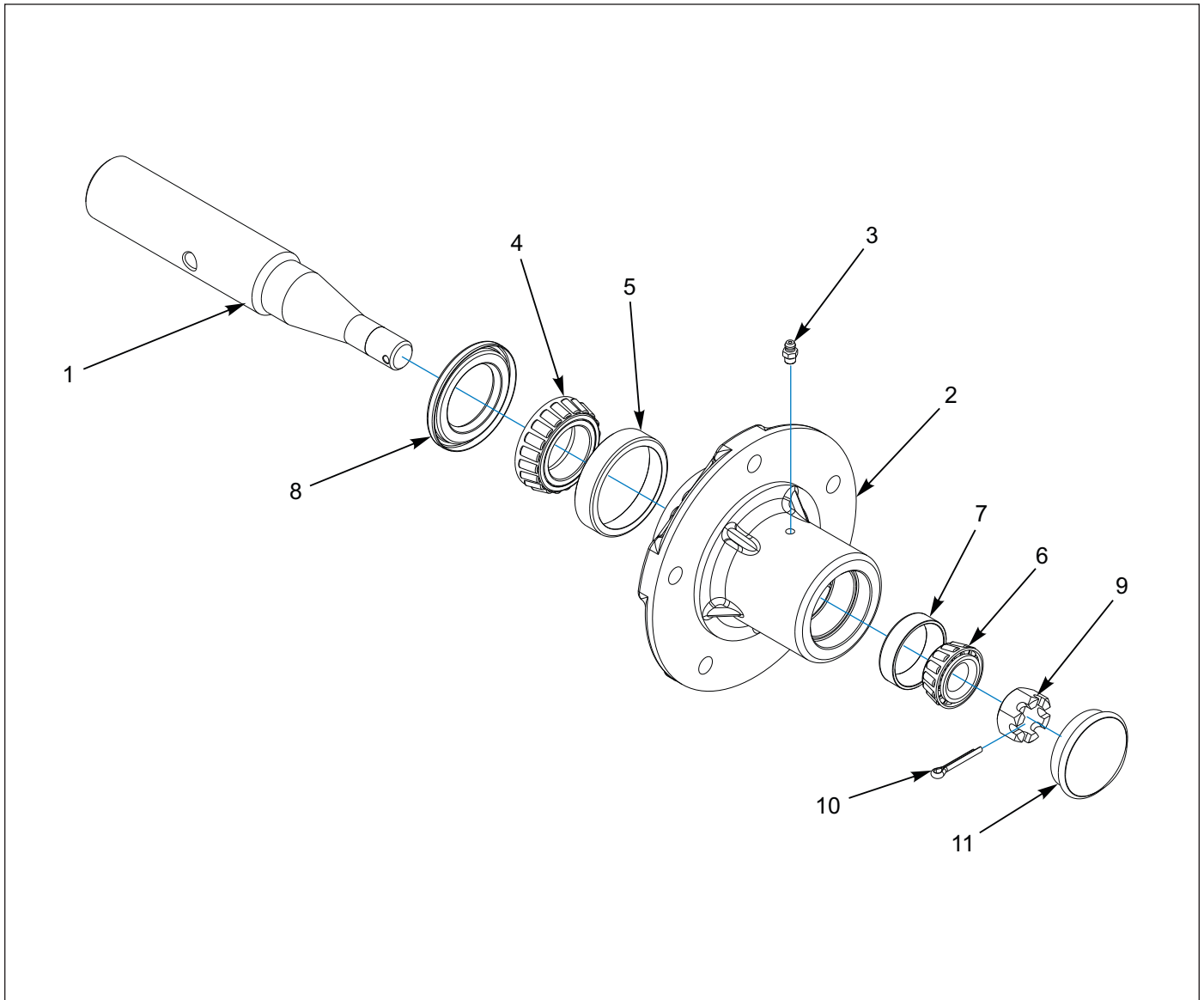

Figure 1-19: Hub and Spindle Assembly

Hub and Spindle Assembly

ITEM	PART NUMBER	DESCRIPTION	QTY
	1J398	HUB & SPINDLE ASSEMBLY	1
1	1J377	SPINDLE	1
2	1J390	WHEEL HUB - 5 BOLT (INCLUDES ITEM 3)	1
3	1-298-010001-1	ZERK FITTING 1/4 SAE	1
4	712099	BRG CONE, TIMKEN LM48548	1
5	2107649	BRG CUP, TIMKEN LM48510	1
6	1-076-010008	BRG CONE, TIMKEN LM11949	1
7	5C912	BRG CUP, TIMKEN LM11910	1
8	1D273	SEAL, SINGLE LIP	1
9	3/4-16HSN	NUT, HX SLOT 3/4-16 HSN	1
10	110-0344	5/32 X 1 COTTER PIN	1
11	1J463	HUB CAP	1

Wheel and Tire

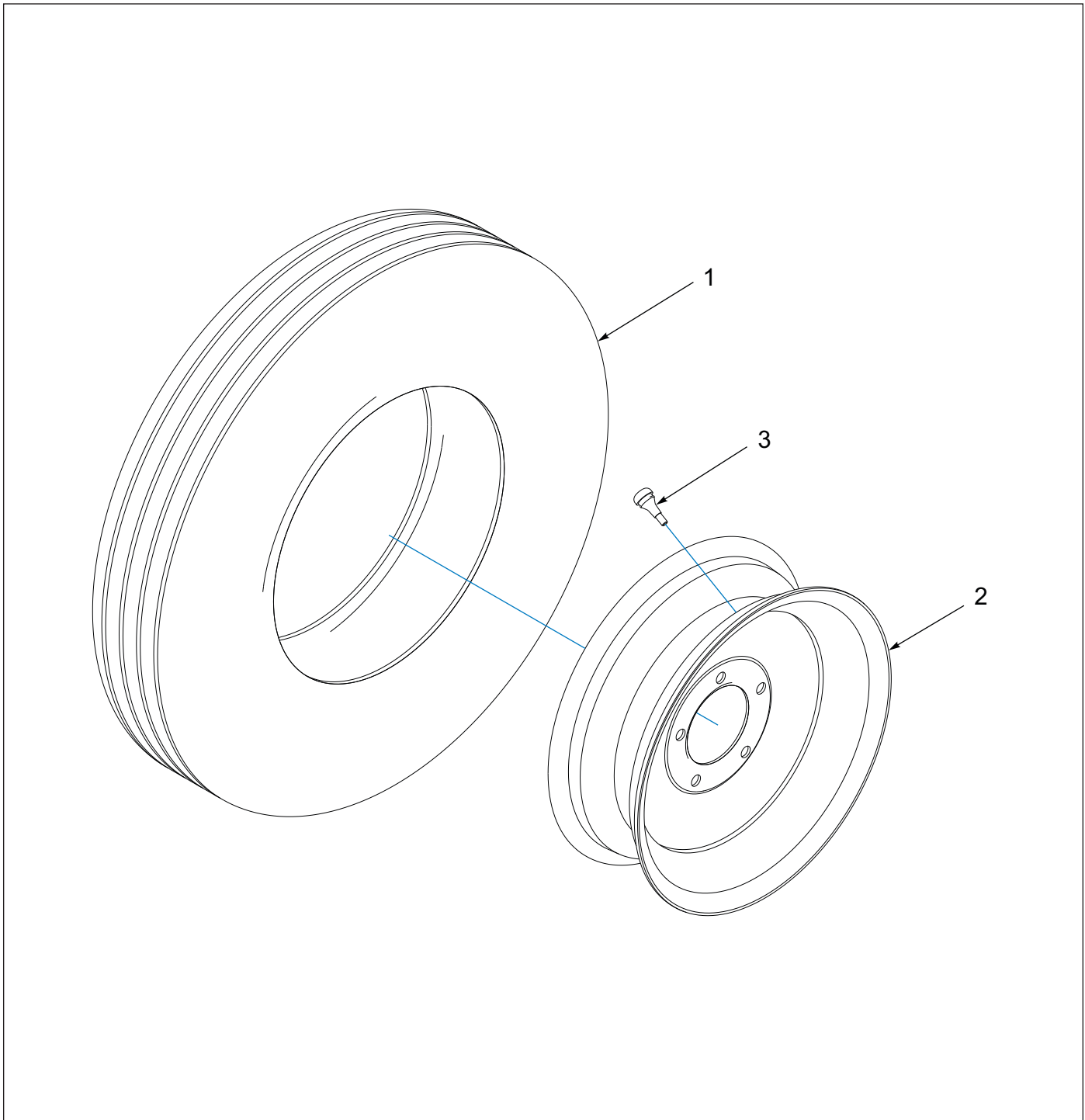

Figure 1-20: Wheel and Tire

Wheel and Tire

ITEM	PART NUMBER	DESCRIPTION	QTY
	6K911	WHEEL 8J789/NO TUBE/4C129	1
1	8J789	TIRE - 7.60 X 15 - 6 PLY	1
2	4C129	WHEEL - 15 X 5KB - 5 BOLT	1
3	415	VAVLE STEM	1

Decals

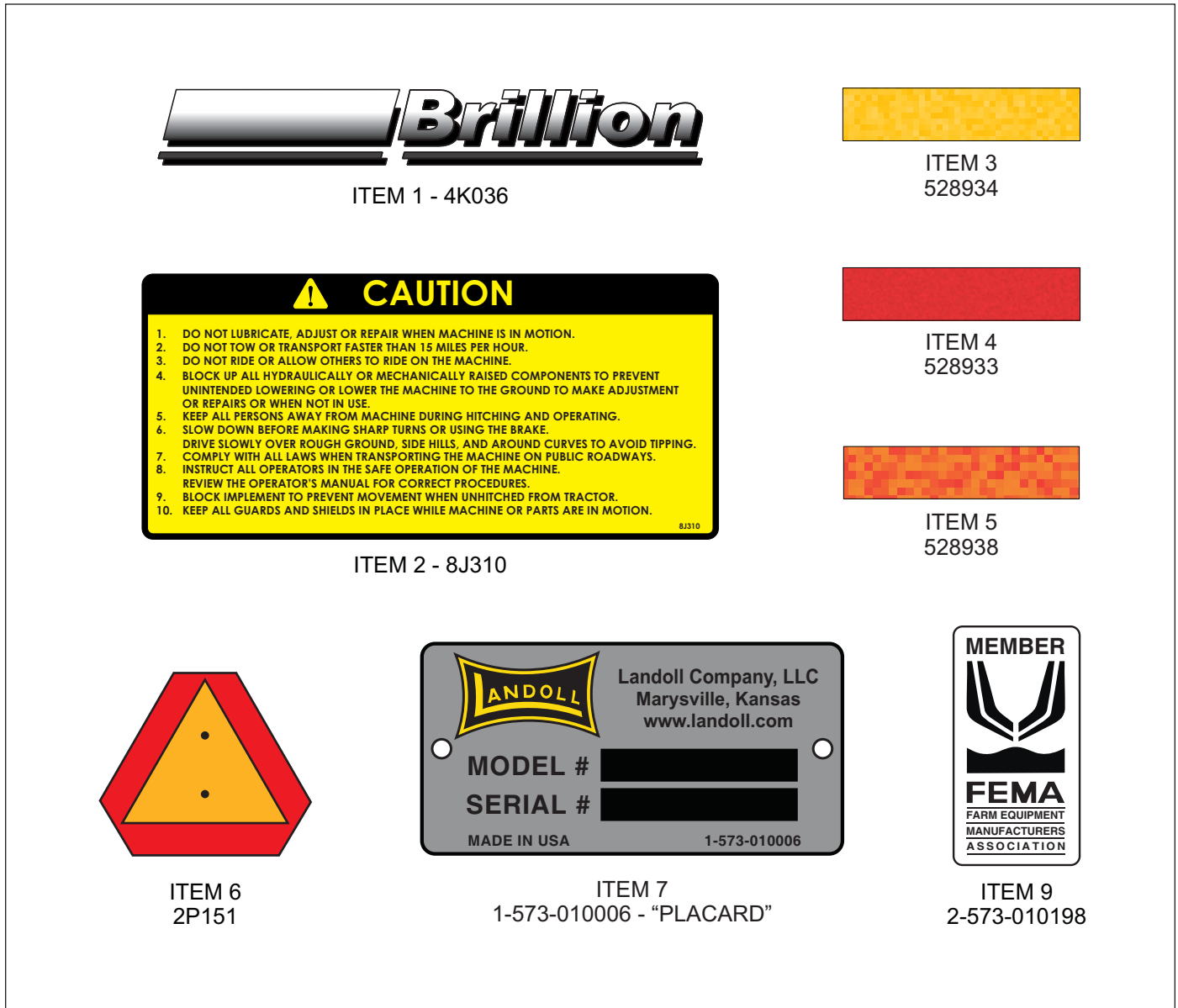

Figure 1-21: Decals

Decals

ITEM	PART NUMBER	DESCRIPTION	QTY
1	4K036	DECAL-BRILLION (2 3/4 X 20)	6
2	8J310	DECAL - CAUTION	1
3	528934	REFLECTOR - YELLOW (7, 9, 10, 12 SHANKS, QTY=4) (11 SHANKS, QTY=6)	REF
4	528933	REFLECTOR - RED (7, 9, 10, 12 SHANKS, QTY=4) (11 SHANKS, QTY=6)	REF
5	528938	STRIPE, ORANGE	2
6	2P151	SMV W/BACKET	1
7	1-573-010006	PLACARD, NAME	1
8	107-0814	RIVET 1/8X1/8 A LUM POP (HARDWARE FOR ITEM 7)	2
9	2-573-010198	DECAL, MEMBER FEMA	1

Decal Locations

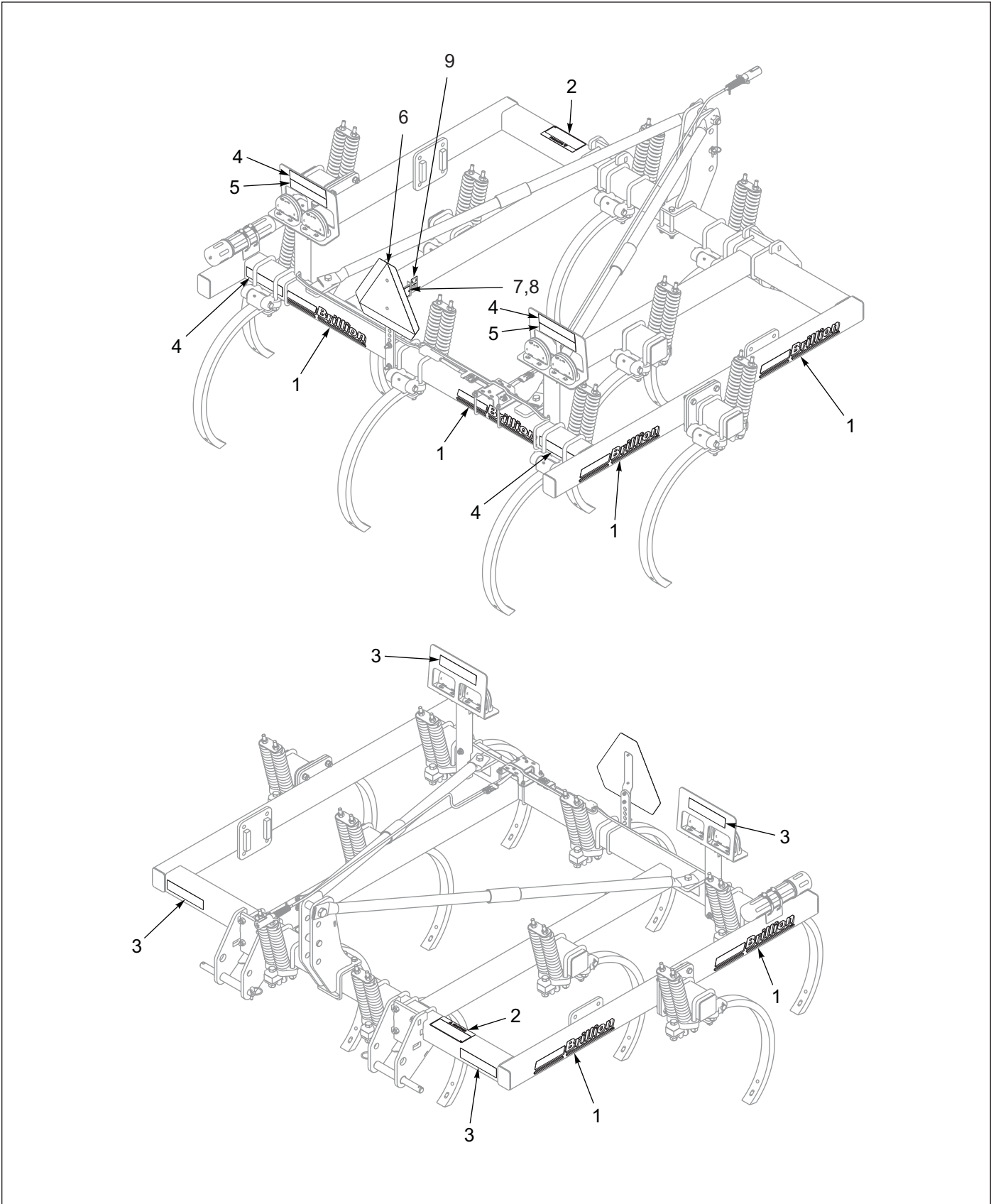

Figure 1-22: Decals (7 and 9 Shank Models)

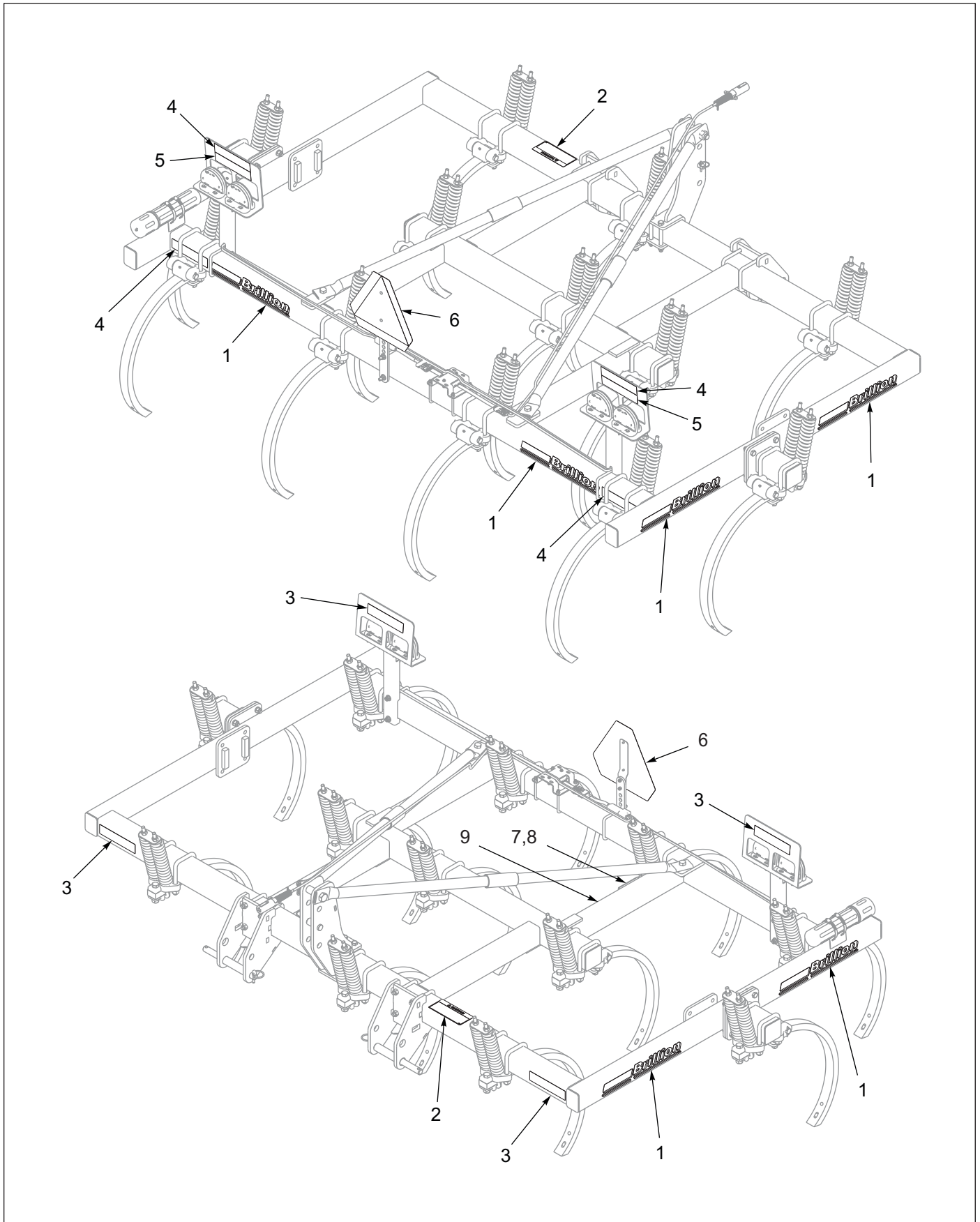

Figure 1-23: Decals (10 and 12 Shank Models)

ILLUSTRATED PARTS LIST

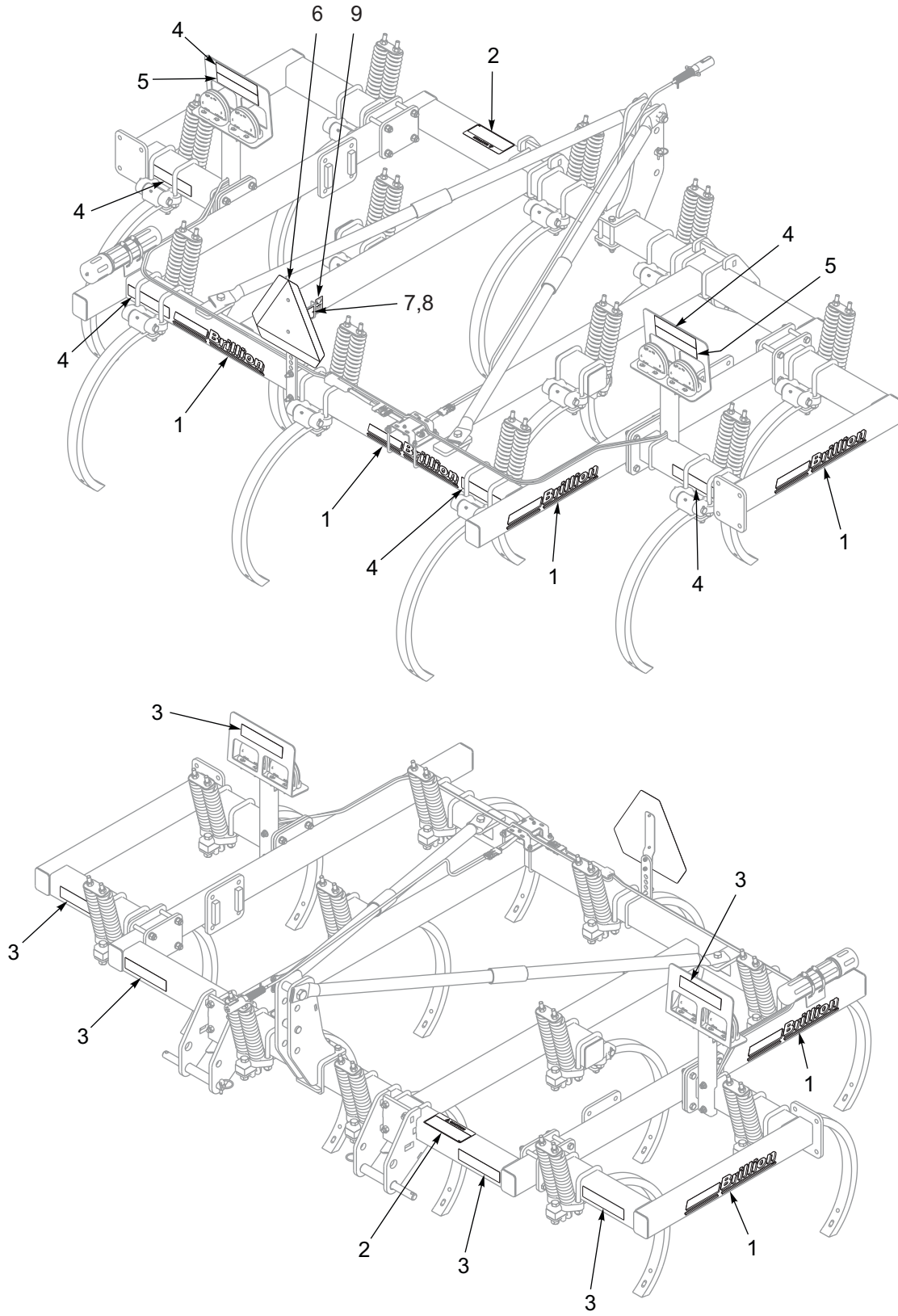

Figure 1-24: Decals (11 Shank Models)

Glossary

For clarity this glossary of industry standard abbreviations and their definitions are provided. For additional information, see instruction on the first page of the parts chapter or the last page of this manual.

A

ASM Assembly

B

BATT Battery
BHSC Button Head Socket Cap
BLK Black

C

CB Carriage Bolt
CONN Connector
CRG Carriage
CTSK Countersunk
CTWT Counterweight
CVR Cover
CYD Cylinder

D

DBL Double
DIA Diameter

E

ENCLSD Enclosed

F

FHCS Flanged Head Cap Screw
FHHCS Flanged Hex Head Cap Screw
FL OR FLG Flange
FLT Flat

G

GA Gauge

H

HHCS Hex Head Cap Screw
HCS High Carbon Steel
HD Head
HLCL Helical
HCSKT Hex Socket
HSFC Hex Socket Flat Countersunk
HYD Hydraulic

I

ID Inside Diameter

L

LH Lefthand
LKG OR LOCK Locking
LWR Lower

M

MANF Manifold
MNT Mount

N

NRW Narrow
 ----- Not Serviced Separately

O

OD Outside Diameter
OHG Overhead Guard
ORFS OR ORS O-Ring Seal
ORP OR ORB O-Ring Boss

P

P-STEER Power Steering
PTFE Polytetrafluoroethylene (Teflon)

GLOSSARY

R

RH Righthand
RND Round

S

SER Series
SHCS Socket Head Cap Screw
SHLD Shield
SKT Socket
SLFLKG Selflocking
SOC Socket
SPDT Single Pole Double Throw
SPR Spring
SQ Square
SRTD Serrated
SSCR Setscrew
SST Stainless Steel
STD Standard

U

UPR Upper

W

WHL Wheel
WLD OR WLDMT Weldment

Numerics

1/2-13X3PLOW	1-13	178506	1-15, 1-17, 1-19
104032	1-3, 1-5, 1-7	178507	1-15, 1-17, 1-19
1-076-010008	1-27	178514	1-15, 1-17, 1-19
108841	1-3, 1-5, 1-7, 1-22	178525	1-15, 1-17, 1-19
110-0344	1-27	178554	1-15, 1-17, 1-19
1-298-010001-1	1-11, 1-27	1-861-010032-09	1-3, 1-5, 1-7
141776	1-11	1-861-010034-15	1-3, 1-5, 1-7, 1-11, 1-12, 1-20, 1-21, 1-23, 1-24
1-512-010005-01	1-15, 1-17, 1-19	1-861-010034-17	1-3, 1-5, 1-7, 1-8, 1-11, 1-12
1-512-010005-05	1-25, 1-26	198938	1-3, 1-5, 1-7, 1-22
1-512-010005-13	1-3, 1-5, 1-7, 1-11, 1-22	198939	1-3, 1-5, 1-7, 1-22
1-512-010005-19	1-3, 1-5, 1-7	198944	1-3, 1-5, 1-7
1-512-010007-11	1-3, 1-5, 1-7, 1-11, 1-20, 1-21, 1-23, 1-24	198946	1-22
1-512-010007-12	1-3, 1-5, 1-7, 1-8, 1-11, 1-12	198947	1-22
1-512-010007-13	1-12	198951	1-3, 1-5, 1-7
1-557-010327	1-3, 1-5, 1-7	1D273	1-27
164678	1-3, 1-5, 1-7	1J377	1-27
1-647-010004217	1-11	1J390	1-27
1-654-010047-08	1-15, 1-17, 1-19	1J398	1-25, 1-26, 1-27
1-654-010049-05	1-3, 1-5, 1-7	1J402	1-23, 1-25
1-654-010051-13	1-25, 1-26	1J404	1-24, 1-26
1-654-010059-05	1-3, 1-5, 1-7, 1-20, 1-21	1J463	1-27
1-654-010059-09	1-23, 1-24	1J469	1-23, 1-24
1-654-010059-15	1-7	2107649	1-27
1-654-010059-17	1-3, 1-5, 1-7	2-557-010417	1-3, 1-5, 1-7, 1-22
1-654-010059-21	1-12	2J091	1-11
1-654-010061-07	1-3, 1-5, 1-7	2J092	1-11
1-654-010061-20	1-12	2J094	1-11
1-654-10065-17	1-3, 1-5, 1-7	2J096	1-11
168344	1-25	2J644	1-8, 1-12
168345	1-26	2P151	1-3, 1-5, 1-7, 1-29
174435	1-15, 1-17, 1-19	2P252	1-15, 1-17, 1-19
174436	1-15, 1-17, 1-19	2P253	1-3, 1-5, 1-7, 1-15, 1-17, 1-19
174437	1-15, 1-17, 1-19	3/4-16HSN	1-27
		3J562	1-3, 1-5, 1-7, 1-15, 1-17, 1-19

INDEX

415	1-28	7D442	1-5
4C129	1-28	7D472	1-3, 1-5, 1-7
4J293	1-8	7D473	1-3, 1-5, 1-7
4J675	1-11	7K964	1-13
4J681	1-8, 1-11	8J130	1-11
4K036	1-29	8J310	1-29
4K076	1-11	8J789	1-28
4K551	1-13	9D989	1-3, 1-5, 1-7, 1-22
4K552	1-13		
528933	1-29		
528934	1-29		
528938	1-29		
5C100	1-23, 1-24		
5C912	1-27		
5D157	1-3, 1-5, 1-7		
6D213	1-13		
6D215	1-13		
6D216	1-13		
6D226	1-20		
6D227	1-21		
6D234	1-12		
6D271	1-3, 1-5, 1-20, 1-21		
6D273	1-7		
6D280	1-11, 1-12		
6D283	1-8, 1-12		
6D298	1-12		
6D299	1-7		
6D362	1-11		
6D409	1-11		
6D529	1-3, 1-5, 1-7		
6D913	1-8, 1-12		
6D946	1-23		
6D988	1-3, 1-5, 1-7		
6J459	1-11		
6K911	1-23, 1-24, 1-28		
712099	1-27		
7D017	1-3, 1-7		
7D441	1-24		

Instructions for Ordering Parts

**** Repair parts must be ordered through an Authorized Dealer ****

DEALER INSTRUCTIONS FOR ORDERING PARTS FROM LANDOLL PARTS DISTRIBUTION CENTER

Phone #: 800-423-4320 or 785-562-5381

Fax #: 888-527-3909

Order online: dealer.landoll.com

IDENTIFICATION PLATE

The Identification Plate, which lists the model and serial number of the equipment. It is located on the rear left hand, inside frame of the Chisel Plow.

SERIAL NUMBER NOMENCLATURE

The serial number for the Chisel is located on the identification plate. The following information will help decode the Landoll serial number.

CPD24000100 = xxmysssss

xx	= model series (i.e. "CP" for all Chisel Plows)
m	= month of manufacture (ex. "D" means April. The letter I is not used.)
yy	= last digits of the year manufactured (ex. "24" means 2024)
sssss	= Sequential number used to track warranty and service information.



Identification Plate

Manuals for 3-Bar Chisel Plow

Manual Number	Manual Type
7D525	Operator's Manual
7D524	Parts Manual

Document Control Revision Log:

Date	Form #	Improvement(s): Description and Comments
07/2001	7D524-0701	Initial Release
11/2013	7D524-1113	Update to the Landoll format. Added LED Warning Lights (175rev1113)
01/2024	7D524-2401	Revised Landoll Template *Revised Form Format "Year/Date" Updated ISO logos to ISO 9001:2015 (Revised 04/2024)



intertek

Equipment from Landoll Company, LLC is built to
exacting standards ensured by ISO 9001:2015 registration
at all Landoll manufacturing facilities.

Chisel Plow, 3-Bar Mounted Models: CPP7 thru CPP12 Parts Manual

Re-Order Part Number 7D524

LANDOLL COMPANY, LLC

1900 North Street

Marysville, Kansas 66508

(785) 562-5381

800-428-5655 ~ WWW.LANDOLL.COM



Copyright 2024. Landoll Company, LLC

“All rights reserved, including the right to reproduce this material or portions thereof in any form.”

