

ASSEMBLY INSTRUCTIONS OPERATOR'S MANUAL



Flail Shredder

MODELS: (12 FT) FS1445 FS1446
(15 FT) FS1805 FS1806

CONTENTS

Introduction	3
Location Reference	3
Parts Ordering	3
Safety Suggestions	4
Safety Signs & Decal Locations	4A
Operating Instructions	5
Transport Lock	6
Safety Chain	6
Maintenance	6A
Pulley Alignment	7
Belt Tension	7
Knife Replacement	8
Shipping Bundles	9
Assembly Instructions	9
Specifications11
Model Designations11
Optional Equipment11

INTRODUCTION

To obtain maximum benefits from the Brillion Flail Shredder, please study this manual carefully before starting assembly or operation. A special section, "Assembly Instructions", is included.



This Safety Alert symbol is used to call your attention to instructions concerning personal safety. Federal law requires you to explain the safety and operating instructions furnished with this machine to all employees before they are allowed to operate the machine. These must be repeated to the employees at the beginning of each season. Be sure to observe and follow the instructions for the safety of anyone operating or near the machine.

Location Reference

Right hand, left hand and forward designations are those related to the operator when sitting in the operating position.

Parts Ordering

When ordering parts for this machine, include the complete model number and serial number. Refer to the name plate on the right hand end plate of the machine. Please record these numbers upon taking delivery of the machine. (See illustration below.)

Flail Shredder Model _____
Serial Number _____
Date Purchased _____

Be sure to read the warranty card which is shipped with the machine. Return the proper part of the card for recording at the factory.

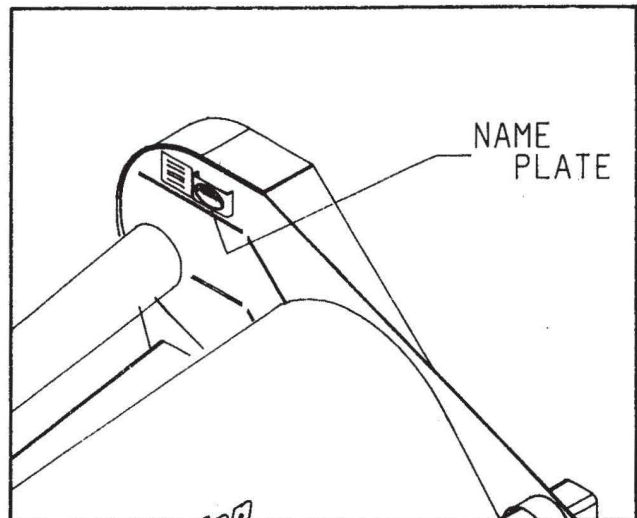



SAFETY SUGGESTIONS

Investigation has shown that nearly 1/3 of all farm accidents are caused by careless use of machinery. You can do your part in improving safety by observing the following suggestions. Insist that all people working with you or for you abide by them.

1. Do not stand between the tractor and shredder when attaching or detaching shredder unless both are not moving.
2. Before applying pressure to the system, be sure all connections are tight and that hydraulic lines and hoses are not damaged.
3. Escaping fluid under pressure can be nearly invisible and have enough force to penetrate the skin causing serious injury. Use a piece of cardboard, rather than hands, to search for suspected leaks. If injured by fluid, see a doctor at once.
4. Do not make adjustments or lubricate or clean shredder while any part of it is in motion.
5. Do not allow anyone to remain in vicinity of shredder when starting or operating.
6. Remain on tractor while Power-take-off is in motion.
7. Do not operate in excess of standard Power-take-off speed.
8. Do not allow anyone to ride on tractor or machine.
9. Do not transport at speeds over 20 miles per hour.
10. When transporting the machine on a road or highway, use adequate warning symbols, reflectors, lights, and slow-moving-vehicle signs as required. Use a safety chain.
11. Avoid sudden stops or turns when transporting because the weight of machine may cause operator to lose control of tractor. Use a tractor heavier than the machine. Do not allow tractor drawbar to swing when in transport.
12. Use caution when towing behind articulated steering tractors; fast or sharp turns may cause the machine to shift sideways.
13. Block shredder so it will not roll when unhitched from tractor.
14. Relieve pressure in hydraulic lines before uncoupling hydraulic hoses from tractor. On most tractors this can be done by operating valves after the engine is stopped.
15. Securely block up machine when working on or under it to prevent injury in case of hydraulic failure or inadvertent lowering by another person. Do not use hydraulic cylinder to support machine when working under it.
16. Lower machine to ground when not in use.
17. Keep all shields in place. Replace damaged shields.



SAFETY WARNING SIGNS - Decal Locations

The safety signs illustrated on this page are placed on the machine to warn of hazards. The warnings found on the signs are for your personal safety and the safety of those around you. **OBSERVE THESE WARNINGS!**

Keep these signs clean so they can be observed readily. Wash with soap and water or cleaning solution as required to keep them visible.

Replace safety signs should they become damaged, painted over or if they are missing. When replacing decals, clean the machine surface thoroughly using soap and water or cleaning solution to remove all dirt and grease.

The safety signs for this machine are illustrated below. See page 4B for their locations on the machine.

1. 5D019-CAUTION 540 RPM ONLY
5D020-CAUTION 1000 RPM ONLY
2. 9C594-TRANSMISSION BOX CAUTION
3. 2J099-ROTATING DRIVE LINE
4. 4K031-THROWN OBJECT HAZARD
5. 3K706-HYDRAULIC LEAKS WARNING
6. 5D006-CAUTION LIST
7. 8J273-LUBRICATION INSTRUCTIONS
8. 3K696-DANGER, ROTATING DRIVELINE
9. 2J430-REFLECTIVE RED
10. 2J431-REFLECTIVE AMBER

1 **CAUTION**
THIS TRANSMISSION BOX
FOR 540 RPM ONLY

2 **IMPORTANT**
THIS TRANSMISSION BOX
SHIPPED WITHOUT OIL!
BEFORE STARTING MACHINE
ADD OIL. SEE 5'S

3 **DANGER**
ROTATING DRIVE LINE
FAILURE TO HEED THESE WARNINGS MAY
RESULT IN PERSONAL INJURY OR DEATH.
KEEP CLOTHING, YOURSELF
AND OTHERS WELL CLEAR.
DO NOT OPERATE UNLESS PTO GUARDS,
TRACTOR HARTER SHIELD AND IMPLEMENT
GUARDS ARE IN PLACE.
ROTATING SHAFT UNDER THIS COVER.
WATCH FOR MOVEMENT.
DO NOT LIFT COVER UNTIL ALL
MOVEMENT HAS STOPPED.

4 **WARNING**
THROWN OBJECT HAZARD
KEEP AWAY
TO PREVENT PERSONAL INJURY OR DEATH
FROM THROWN OBJECTS, STAY AWAY FROM
DISCHARGE AREA DURING OPERATION.
KEEP FINGERS OUT OF VICINITY WHILE
OPERATING.

5 **WARNING**
DO NOT GO NEAR LEAKS
High pressure oil easily penetrates
skin causing serious injury,
gangrene or death.
If injured, seek emergency medical
help. Immediate surgery is
required to remove oil.
Do not use fingers or skin to
check for leaks.
Lower load or relieve hydraulic
pressure before loosening fittings.
10813A

6 **CAUTION**
1. DO NOT UNDER ANY CIRCUMSTANCES ALLOW ANYONE TO REMAIN IN VICINITY OF MACHINE WHEN STARTING OR OPERATING.
2. OPERATOR MUST REMAIN ON TRACTOR WHILE POWER TAKE OFF IS IN MOTION.
3. NEVER MAKE ADJUSTMENTS, LUBRICATE, OR CLEAN MACHINE WITH ANY PART OF MACHINE IN MOTION.
4. DO NOT PERMIT TRACTOR RIDERS OTHER THAN OPERATOR. DO NOT ALLOW ANYONE TO RIDE THE MACHINE.
5. DO NOT OPERATE SHREDDER IN EXCESS OF STANDARD TRACTOR PTO SPEED.
6. BE CAREFUL. OBSERVE ALL STANDARD SAFETY PRECAUTIONS.
7. BLOCK UP MACHINE BEFORE ATTEMPTING SERVICE UNDER MACHINE. DO NOT USE HYDRAULIC CYLINDER TO SUPPORT MACHINE WHEN WORKING UNDER IT.

7 **LUBRICATION INSTRUCTIONS**
1. GREASE P.T.O. JOINTS AND TELESCOPING SHAFT AND TUBE ASSEMBLY DAILY.
2. GREASE UNIVERSAL JOINT ON CROSS SHAFTS DAILY.
3. GREASE THE SIX FLANGE BEARINGS AND THE THREE REAR PIVOT TUBE BEARINGS EVERY 40-50 HOURS. (THERE IS ONE FLANGE BEARING ON THE OUTER END OF EACH CROSS SHAFT AND ONE ON EACH END OF THE TWO ROTORS. THE BEARING ON THE INNER END OF EACH ROTOR IS MOUNTED ON THE CENTER PLATE OF THE MACHINE.)
4. REPACK WHEEL BEARINGS ONCE A YEAR.
5. CHECK OIL LEVEL IN GEARBOX BEFORE USING. MAINTAIN LEVEL WITH PROPER GRADE OF LUBRICANT. CHANGE OIL AT THE BEGINNING OF EACH SEASON.

8 **DANGER**
DANGER-ROTATING DRIVELINE
CONTACT CAN CAUSE DEATH
KEEP AWAY!
DO NOT OPERATE WITHOUT-
• ALL DRIVELINE, TRACTOR AND EQUIPMENT BEARING IN PLACE
• DRIVELINE SECURELY ATTACHED AT BOTH ENDS
• DRIVELINE SHIELD THAT TURNS FREELY ON DRIVELINE

9 10

OTHER DECALS FOUND ON THE FLAIL SHREDDER:

11 THIS MACHINE PRODUCED UNDER ONE OR MORE OF THE FOLLOWING PATENTS:
US 3,070,084 US 3,390,727
US 3,555,797 US 4,534,416
US 4,871,030
CANADA 1,223,476

11. 8D387-PATENT
12. 4K036-"BRILLION" 2 3/4" x 20"
13. 4K039-"BRILLION" 3 3/4" x 40"



LOCATION OF SAFETY SIGNS AND DECALS -12' AND 15' FLAIL SHREDDER

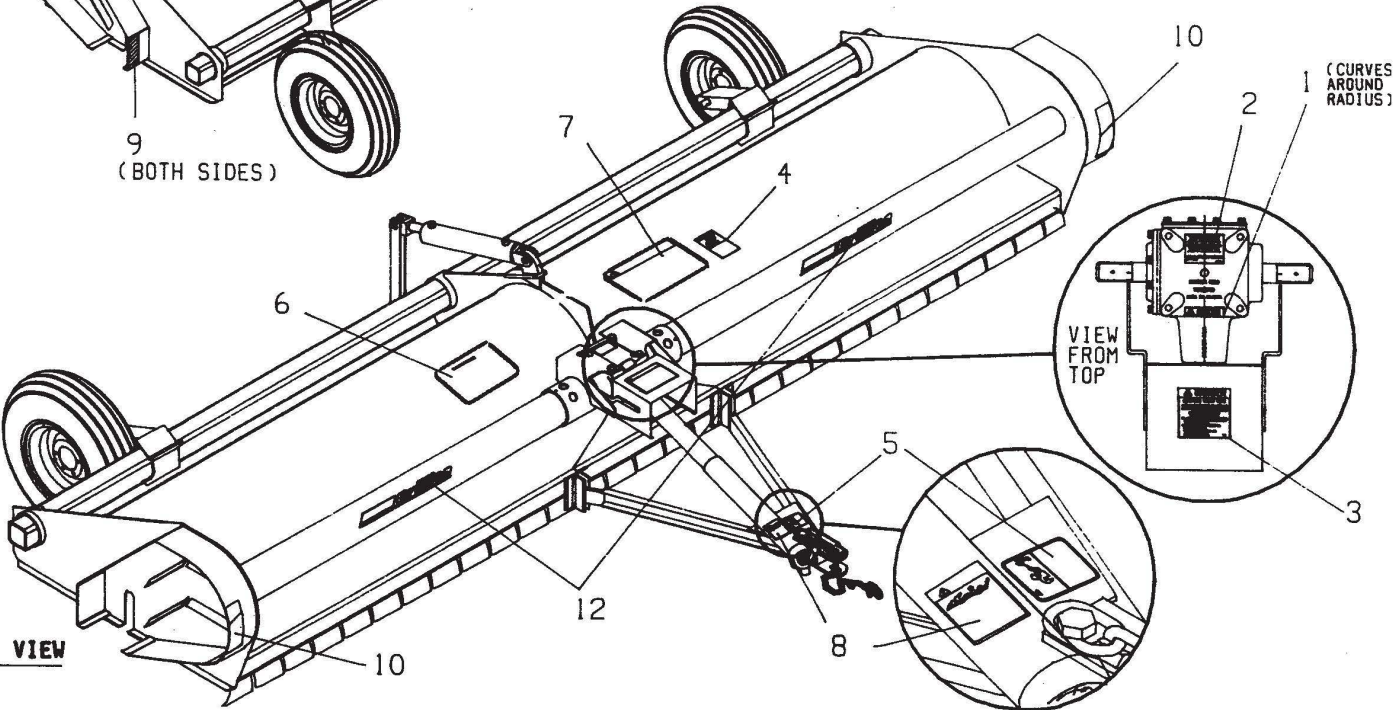
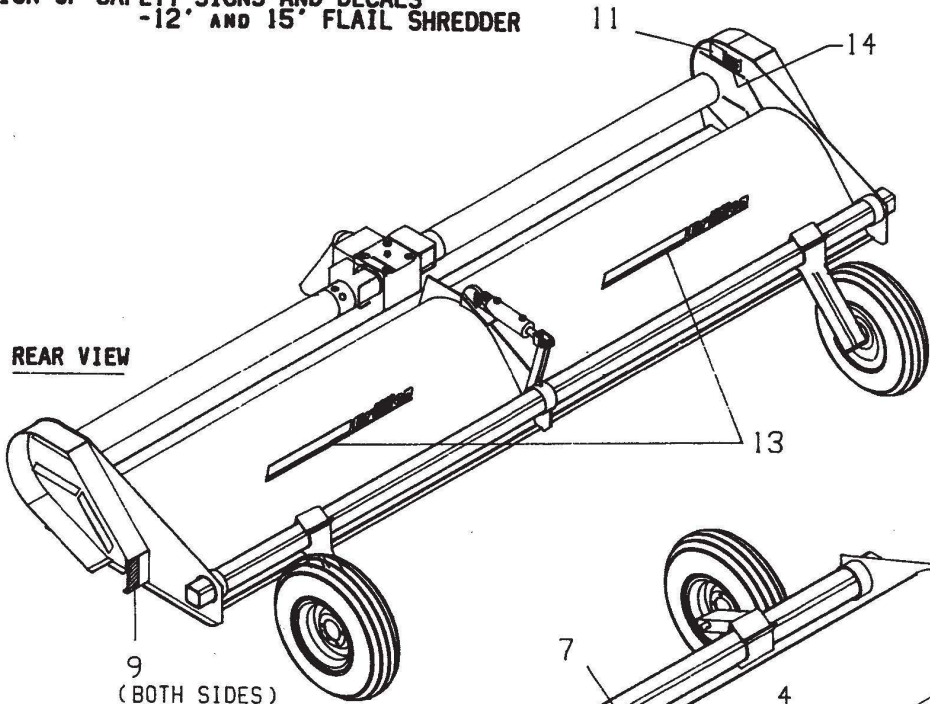

1. 5D019-CAUTION 540 RPM ONLY
5D020-CAUTION 1000 RPM ONLY
2. 9C594-TRANSMISSION BOX CAUTION
3. 2J099-ROTATING DRIVE LINE
4. 4K031-THROWN OBJECT HAZARD
5. 3K706-HYDRAULIC LEAKS WARNING
6. 5D006-CAUTION LIST
7. 8J273-LUBRICATION INSTRUCTIONS
8. 3K696-DANGER, ROTATING DRIVELINE
9. 2J430-REFLECTIVE RED
10. 2J431-REFLECTIVE AMBER
11. 8D387-PATENT
12. 4K036-"BRILLION" 2 3/4" x 20"
13. 4K039-"BRILLION" 3 3/4" x 40"
14. NAME PLATE (PART * VARIES W/
MACHINE)

THIS PAGE LEFT BLANK INTENTIONALLY

OPERATING INSTRUCTIONS

Tractor Preparation

Make sure tractor drawbar hitch hole is positioned correctly for the power take-off speed to be used.

540 RPM 1-3/8 6 spline: 14" end of PTO shaft to hole center.

1000 RPM 1-3/8 21 spline: 16" end of PTO shaft to hole center.

Center PTO shaft to top of drawbar: 8" preferred, 6" minimum, 12" maximum.

Make sure tractor power take-off master shield is in place.

Shredder Operation

Run shredder at its rated RPM. Decal on gearbox shows proper speed, either 540 or 1000 RPM.

Check to make sure drain plug on gear box is tight.

Important - When operating shredder, maintain ground clearance (2" recommended minimum) on flail knives. If hydraulic cylinder has a stroke control on it, adjust stop to provide proper cutting height.

Do not make sharp turns when machine is running. Turning too short will cause vibration and may result in damage to the implement drive line universal joints and to the machine. It is advisable to skip 8 or 12 rows when turning around at the end of the field. If tractor is equipped with an overriding or free turning PTO shaft, it is advisable to disengage PTO when turning.

When changing cutting height, adjust the turnbuckle on the hitch to keep the machine as level as possible. Attach the screw jack to the front of the shredder frame and use it to raise and lower the machine to relieve load on the turnbuckle while adjusting.

Store the screw jack on the top position, out of the way, when not in use.

Never operate machine without a full set of knives. If one knife assembly is replaced with a new one, the closest one, 180° opposite must also be replaced with a new one. See figure.

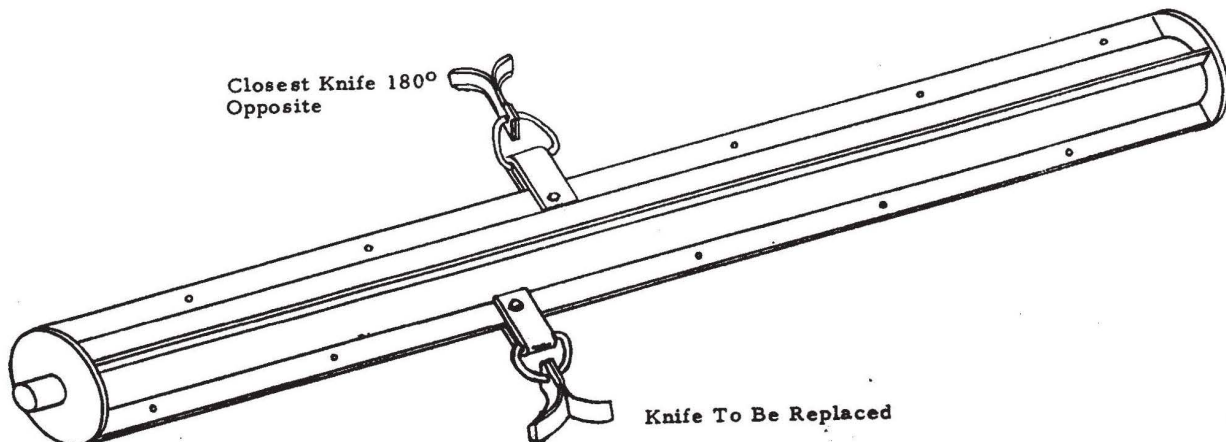

Transport Lock

To prepare machine for transport, raise it fully and assemble lock pin and spacers as shown in view at right. (A spacer on each end of pin, held in place with roll pin and hairpin cotter.) When in field position, pin and spacers can be stored in center plate storage hole, just ahead of hydraulic cylinder.

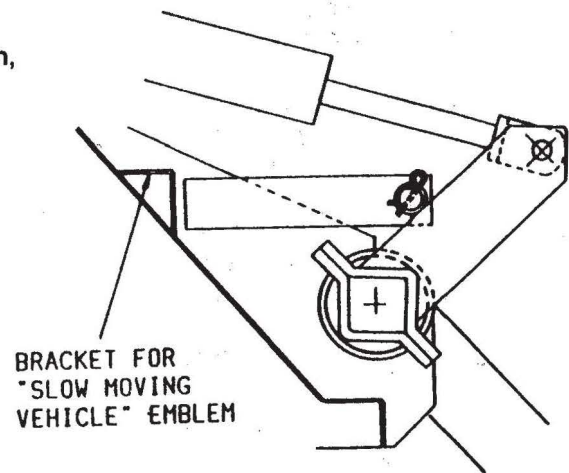

SAFETY CHAIN (Optional)

Use of a safety chain is recommended if the machine is towed on a public road or highway. Chain should be rated at 10,100 pounds minimum in accordance with ASAE S338 specifications. Such a chain, along with hardware to attach to the Flail Shredder is available as Kit # 1K822.

Refer to the drawing below for installation. Slack in chain should be only enough to permit turning. Distance from hitch pin to attachment point or intermediate support should not exceed 9".

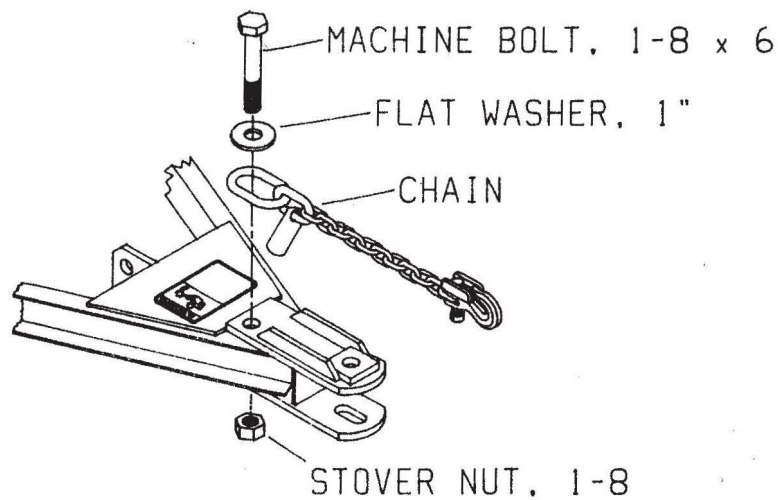

FS FLAIL SHREDDER

MAINTENANCE

Check oil level in gearbox before using. On the side of the gearbox are two plugs. Fill and maintain to lower level plug with proper grade of lubricant. Where temperatures are above 32° F. (0° C.) use SAE Grade 140EP. Below 32° F. (0° C.) use SAE Grade 90EP.

Grease the implement drive assembly including the universal joint crosses and the telescoping tube and shaft. Compress the two halves of the drive line exposing the fitting. Do this daily.

Grease other bearings lightly every 40 to 50 hours of operation. It is necessary to block up the machine and get underneath the machine to grease the two center bearings on the flail assembly. Block the wheels to prevent the machine from moving.



Do not depend on the hydraulic cylinder to support the machine while you are under it. It could collapse and fall on you causing severe injury or even death.

Repack wheel bearings once a year.

Check and retighten all bolts periodically.

Check belt tension and alignment frequently. New belts stretch rapidly in the first few hours of use. See instructions on the next page for proper belt tension and alignment.

Check tire inflation pressures at least once a week. Maximum pressure 20 psi; minimum pressure 10 psi.

Check for blade breakage if there seems to be excessive vibration. Replace any broken blades in pairs as described on page 5.

TO CHECK PULLEY ALIGNMENT

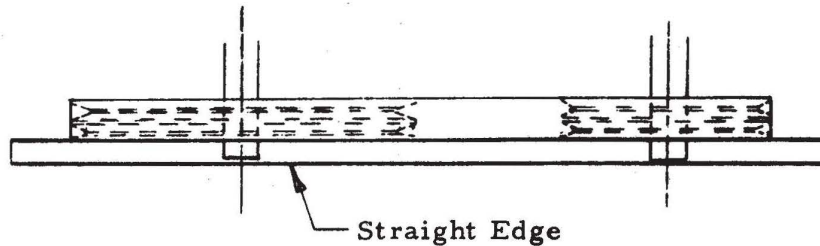

Lay straight edge against both pulleys. Straight edge should touch on both edges of each pulley. It may be necessary to slide the pulley in or out on the shaft, as well as move the gear box to properly align the belts.

It is important to maintain pulley alignment for normal belt life.

TO CHECK PROPER BELT TENSION ON MODELS WITH MULTIPLE "C" SECTION BELTS

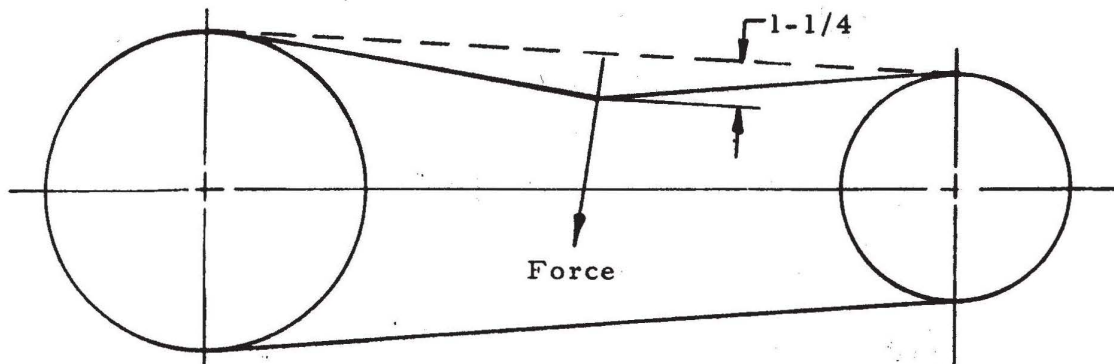

1. Using spring scale at right angles to the center of the span, apply a force to one belt large enough to deflect the belt 1-1/4".
2. The force required should be about 20#. For a new belt that is being tightened for the first time the force required for 1-1/4" deflection should be 30#.
3. At the end of 2-4 hours of operation the belts should be retightened to the normal tension.
4. After 24-48 hours the belt tension should be rechecked. Either too high or too low a belt tension will shorten belt life.

This is a side view showing correct location of retainer used to keep the "D" ring from turning over. The retainers on all the knives on one cylinder must all be put in on the same side of the bar.

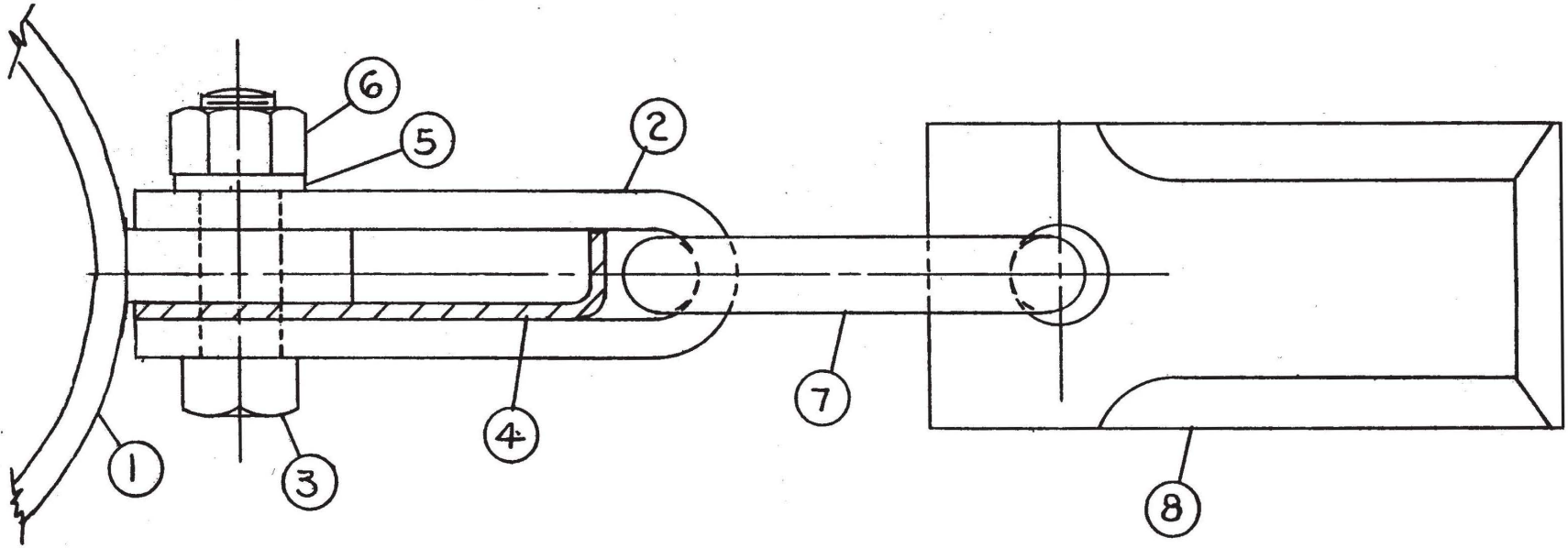

1. Cylinder and bar
2. "U" Bracket
3. Capscrew
4. Retainer
5. Lockwasher
6. Lock Nut
7. "D" Ring
8. Knife

SHIPPING BUNDLES

<u>MODEL</u>	<u>FS1446</u>	<u>FS1446-1</u>	<u>FS1806</u>	<u>FS1806-1</u>
Hood & Drive Assembly	3K652	3K653	3K654	3K655
Wheel Arm Assembly (2)	8J247	8J247	8J881	8J881
Front Hitch Bundle	5D035	5D035	5D035	5D035
Box Assembly (V-Belts)	8J249	8J249	8J249	8J249
Box Assembly (Skirts)	8D356	8D356	8D358	8D358
Wheels (2)	6J189	6J189	6J189	6J189
Drive Shaft Bundle	8J260	8J259	8J260	8J259
Shield Assembly	8J224	8J224	8J224	8J224
Screw Jack	3J880	3J880	3J880	3J880

ASSEMBLY INSTRUCTIONS

Refer to Repair Parts Catalog for identification of parts.

1. Mount tires on wheels. (Tires not furnished with machine). Use 9.5L-15 6-ply tires. Inflate to 36 psi. Reduce inflation to 20 psi.
2. Raise machine high enough to install screw jack at front of machine. Set front of machine about 1' high.
3. Mount tailwheel arms on 3" square rear axle tube. Arms are normally installed with the wheels toward the outside of the machine, but may be reversed depending upon wheel spacing desired. Use the widest possible wheel spacing for machine stability.
4. Mount wheels on hubs.

Note: The view below shows 15' machine. On 12' machines, spindles are welded to wheel arms.

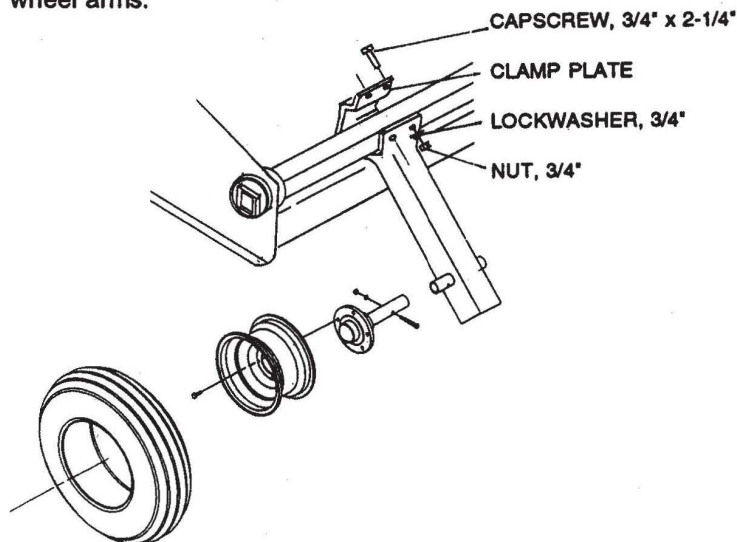

5. Install belts and tighten. See figures and instructions on proper belt tension and alignment on page 7. Tighten belts by loosening mounting bolts on gearbox base and upper pulley bearings, then turn adjusting screws. Move both gearbox and shaft bearings equally to maintain alignment between pulleys and gearbox.

To check alignment of pulleys and gearbox visually, sight along drive shaft shields using front of machine as a reference line.

6. Attach front hitch, with slotted clevis plate down, to front of frame with 1" diameter clevis pins. Then attach two drawbar links to the lower holes on both front hitch and shredder frame, using the remaining clevis pins. Do not operate the machine unless the drawbar links are installed.

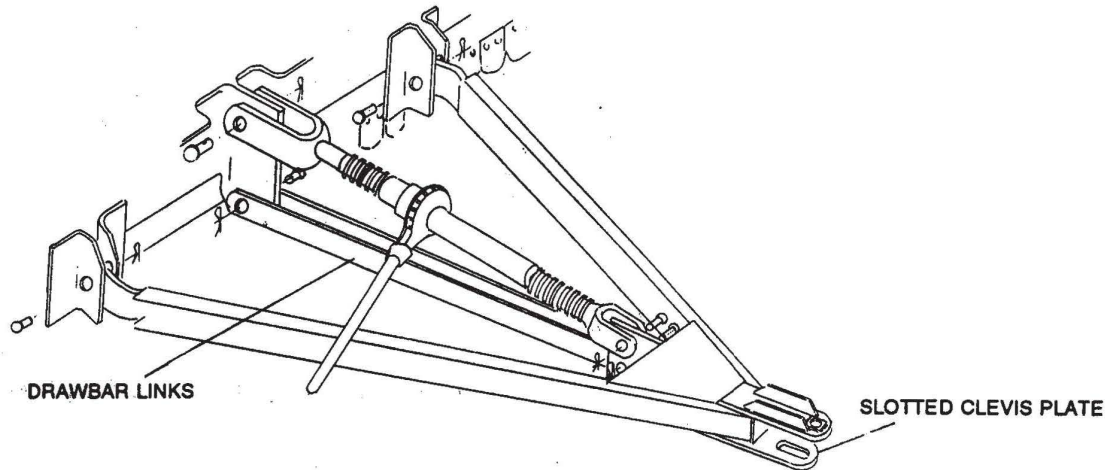

7. Attach the implement end of the telescoping drive line to the gearbox, insert bolt and tighten locknut. Lubricate the telescoping section of the drive line by compressing completely to expose the lube fitting through the holes in the shield.

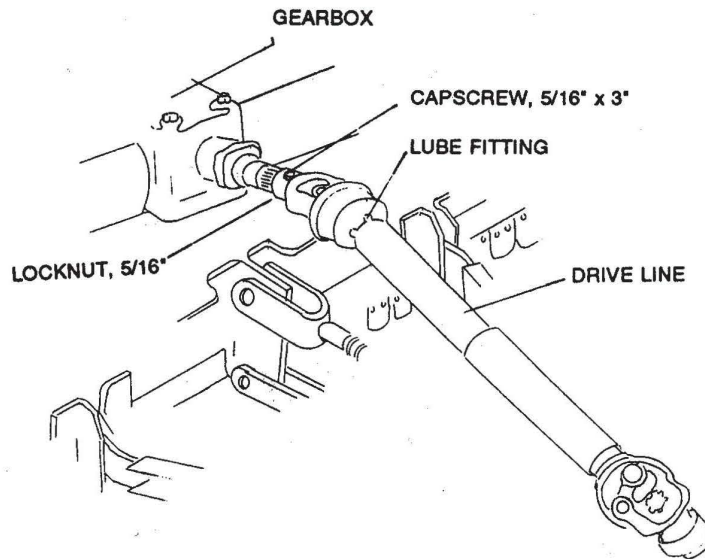

8. To install skirts, insert the end of the rod with the holes in it through the first (outer) lug. Next slide on two skirts. When the rod is all the way in, put a cotter pin in the hole in the end of the rod. Refer to items #7, 8, and 9 on page 2 of the Repair Parts Catalog.
9. The machine is shipped with no grease in the gearbox. On the side of the gearbox you will find a plug located in front of the output shaft. Fill to bottom of the plug hole with the proper lubricant. Use SAE 140 EP when the temperature is above 32°F (0°C), and SAE 90 EP when the temperature is below 32°F (0°C). Do not overfill with lubricant.
10. Install handle in turnbuckle. Install turnbuckle in the upper holes of the hitch and shredder frame using the pins provided.
11. Assemble the base of the hydraulic cylinder to the lug on the top of the shredder housing. Place the rod end clevis between the lift arms of the transport axle and secure with the pin provided. (The distance between pin centers should be set at 28¼" with cylinder fully extended.)
12. Assemble hose support for hydraulic hoses (refer to item #36 and #37 on Page 2 of Repair Parts Catalog). Insert hose support into mounting tube at center of machine and fasten in place with cotter pin provided.
13. Remove breather plug from gearbox. Reassemble breather and extension components as shown below. (If machine is operated with breather mounted directly into the box, a small amount of lubricant might leak from breather plug. This is usually harmless, however.)
14. Assemble the 8J224 Shield Assembly to Brackets 3K079 and 3K080 which are mounted on top of the gearbox. Refer to drawing. (Hardware for attaching is included with the shield assembly.)

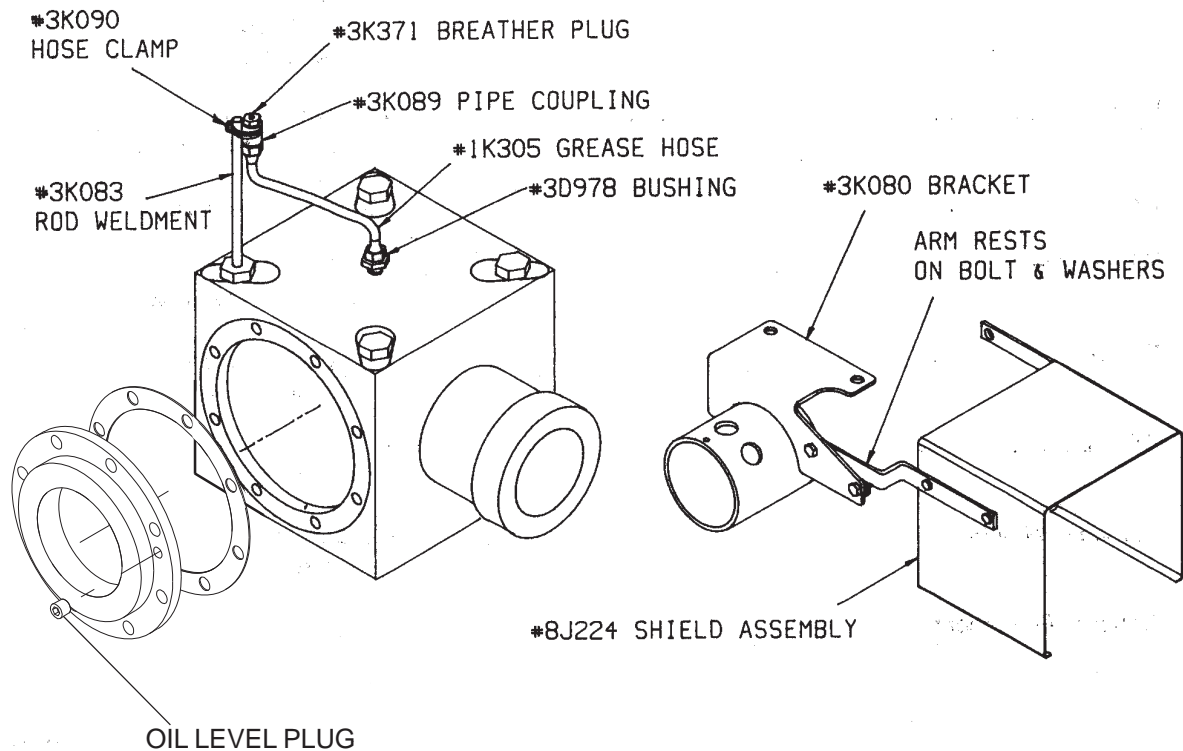

SHREDDER SPECIFICATIONS
 (Subject to change without notice)

Model	FS1446	12' Cutting Width	540 RPM
	FS1446-1	12' Cutting Width	1000 RPM
	FS1806	15' Cutting Width	540 RPM
	FS1806-1	15' Cutting Width	1000 RPM
Height of Cut		Adjustable 0 to 16" 2" recommended minimum
Knives		Heat treated steel Reversible FS1446 96 knives FS1806 128 knives
Gears		Heat treated alloy steel, machine cut, run in oil bath
Bearings		Gear housing tapered roller shim and nut adjusted Wheel hubs tapered roller nut adjusted
Implement Drive Line		Heavy duty, two joint Needle bearing Telescoping
Hitch		Adjusts to drawbar height of tractor
Lift		Hydraulic or manual
Wheel Size		15 x 8 LB rim for 9.5 L - 15 tires
Frame		Heavy gauge steel welded assembly
Drive Belts		Premium C section matched set of three
Shredder Weight		FS1446 2260# FS1806 2540#



Equipment from Landoll Corporation is built to exacting standards ensured by ISO 9001:2008 registration at all Landoll manufacturing facilities.

LANDOLL CORPORATION

1900 North Street

Marysville, Kansas 66508

(785) 562-5381

800-428-5655 ~ WWW.LANDOLL.COM



Copyright 2010. Landoll Corporation

"All rights reserved, including the right to reproduce this material or portions thereof in any form"
