



**Flail Shredder**  
**Models - 1446 and 1806**  
**Series - FS, FSC and FSB**  
**Operator's Manual**



**LANDOLL COMPANY, LLC**

1900 North Street  
Marysville, Kansas 66508  
(785) 562-5381

800-428-5655 ~ [WWW.LANDOLL.COM](http://WWW.LANDOLL.COM)



# Table of Contents

---

## 1 Safety Information

Introduction .....	1-1
Description of Unit .....	1-1
Using this Manual .....	1-1
Owner Assistance .....	1-1
Warranty Registration .....	1-1
Understanding Safety Statements .....	1-2
Keep Riders Off of Machinery .....	1-2
Transporting Safety .....	1-2
Attaching, Detaching and Storage .....	1-3
Maintenance Safety .....	1-3
High Pressure Fluid Safety .....	1-3
Protective Equipment .....	1-3
Chemical Safety .....	1-3
Prepare for Emergencies .....	1-3
Tire Safety .....	1-3
Safety Chain .....	1-4
Safety Signs .....	1-5

## 2 Assembly Instructions

Tires and Wheels .....	2-1
Belts .....	2-1
Hitch .....	2-1

## 3 Operation

Tractor Preparation .....	3-1
Shredder Operation .....	3-1
Transport Lock .....	3-1
Safety Chain .....	3-2

## 4 Preventive Maintenance & Adjustment

Fasteners .....	4-1
-----------------	-----

# Table of Contents

---

Lubrication .....	4-2
To Check Pulley Alignment .....	4-2
Belt Tension On Models With Multiple “C” Section Belts .....	4-2
Cutting Blades .....	4-2

## 5 General Reference Tables and Specifications

## Safety Information

### Introduction

The implement described in this manual has been designed with care and built by skilled workers using quality materials and processes. Proper assembly, maintenance and safe operation will allow this machine to provide you with satisfactory use for seasons to come.



**DANGER**

**Read this entire manual before attempting to assemble, adjust or operate this machine. Failure to comply with this warning can result in personal injury or death, damage to the machine or its components and inferior operation.**

### Description of Unit

The Brillion Flail Shredders facilitate trash decomposition to unlock valuable nutrients in the soil. The shredder features a sturdy curved hood with replaceable wear plates. The rotors are dynamically balanced to provide smooth, vibration free operation.

### Using this Manual

This manual will familiarize you with safety, assembly, operation, adjustment, and maintenance. Read this manual and follow the recommendations to help ensure safe and efficient operation.

The information in this manual is current at time of printing. Some parts may change to assure top performance.

Location reference: Right and Left designations in this manual are determined by facing the direction the machine will travel during field operation, unless otherwise stated.

### Owner Assistance

If customer service or repairs are needed, contact your Brillion dealer. They have trained personnel, parts and service equipment specially designed for Brillion products. Your machine's parts should only be replaced with Brillion parts. Have the Serial Number and complete Model Number available when ordering parts from your Brillion dealer. See Figure 1-1.

### Warranty Registration

Brillion Farm Equipment, by Landoll, shall have no warranty obligation unless each product is registered, within 10 days of retail purchase, using the Landoll Company, LLC Ag Products on-line registration process. Please refer to the Ag Products Policy and Procedures Manual, accessible at [www.landoll.com](http://www.landoll.com) for step by step instructions regarding product registration.

Enter your product information below for quick reference.

MODEL NUMBER

SERIAL NUMBER

DATE OF PURCHASE

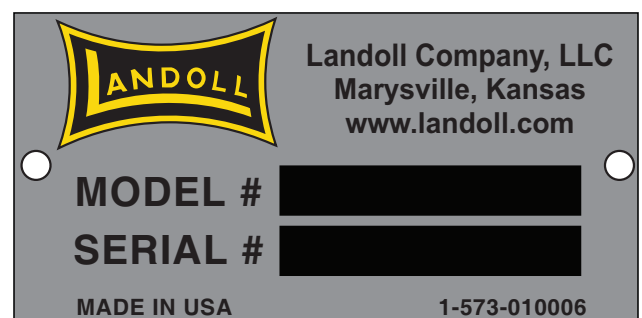

Figure 1-1: ID Plate

## SAFETY INFORMATION

Federal law requires that you explain the safety and operating instructions furnished with this machine to all operators before they are allowed to operate the machine. These instructions must be repeated to the operators at the beginning of each season. Be sure to observe and follow the instructions for the safety of anyone operating or near the machine.

### NOTE

*Investigation has shown that nearly 1/3 of all farm accidents are caused by careless use of machinery. Insist that all people working with you or for you abide by all safety instructions.*

## Understanding Safety Statements

You will find various types of safety information on the following pages and on the machine decals (signs) attached to the implement. This section explains their meaning.

### NOTICE

Special notice - read and thoroughly understand.



### CAUTION

Proceed with caution. Failure to heed caution may cause injury to person or damage product.



### WARNING

Proceed with caution. Failure to heed warning will cause injury to person or damage product.



### DANGER

Proceed with extreme caution. Failure to heed notice will cause injury or death to person and/or damage product.

### NOTE

*You should read and understand the information contained in this manual and on the machine decals before you attempt to operate or maintain this equipment.*

Examine safety decals and be sure you have the correct safety decals for the machine. See Figures 1-3 and 1-4. Order replacement decals through your Brillion dealer.

Keep these signs clean so they can be observed readily. It is important to keep these decals cleaned more frequently than the machine. Wash with soap and water or a cleaning solution as required.

Replace decals that become damaged or lost. Also, be sure that any new machine components installed during repair include decals which are assigned to them by the manufacturer.

When applying decals to the machine, be sure to clean the surface to remove any dirt or residue. Where possible, sign placement should protect the sign from abrasion, damage, or obstruction from mud, dirt, oil etc.



### DANGER

**Do not allow anyone to ride on the tractor or machine. Riders could be struck by foreign objects or thrown from the machine.**

**Never allow children to operate equipment.**

**Keep bystanders away from machine during operation.**

**Keep Riders off Machinery.**

## Transporting Safety

### IMPORTANT

**It is the responsibility of the owner/operator to comply with all state and local laws.**

When transporting the machine on a road or highway, use adequate warning symbols, reflectors, lights and slow moving vehicle sign as required. Slow moving tractors and towed implements can create a hazard when driven on public roads. They are difficult to see, especially at night.

Do not tow an implement that, when fully loaded, weighs more than 1.5 times the weight of the towing vehicle.

Carry reflectors or flags to mark tractor and implement in case of breakdown on the road.

Do not transport at speeds over 20 MPH under good conditions. Never travel at a speed which does not allow adequate control of steering and stopping. Reduce speed if towed load is not equipped with brakes

Avoid sudden stops or turns because the weight of the machine may cause the operator to lose control of the tractor. Use a tractor heavier than the machine.

Use caution when towing behind articulated steering tractors; fast or sharp turns may cause the machine to shift sideways.

Keep clear of overhead power lines and other obstructions when transporting. Know transport height and width of your machine. Refer to transport dimensions. See Table 5-1.

## Attaching, Detaching and Storage

Do not stand between the tractor and implement when attaching or detaching implement unless both are not moving.

Before applying pressure to the hydraulic system, be sure all connections are tight and that hydraulic lines and hoses are not damaged.

Block machine so it will not roll when unhitched from the tractor.

Relieve pressure in hydraulic lines before uncoupling hydraulic hoses from tractor.

### **NOTE**

*On most tractors relieving hydraulic pressure can be accomplished by operating valves after the engine is stopped.*

## Maintenance Safety

Block the machine so it will not roll when working on or under it to prevent injury in case of hydraulic failure or inadvertent lowering by another person.

Do not make adjustments or lubricate machine while it is in motion.

Make sure all moving parts have stopped and all system pressure is relieved.

Understand the procedure before doing the work. Use proper tools and equipment.

Keep all shields in place. Replace damaged shields.

## High Pressure Fluid Safety

Escaping fluid under pressure can be nearly invisible and have enough force to penetrate the skin causing serious injury. Use a piece of cardboard, rather than hands, to search for suspected leaks.

Any fluid injected into the skin must be surgically removed within a few hours or gangrene may result.

Avoid the hazard by relieving pressure before disconnecting hydraulic lines.

### **NOTE**

*On most tractors relieving hydraulic pressure can be accomplished by operating valves after the engine is stopped. Also, the machine should be lowered to ground so that the shanks are taking the load.*

*Wear protective gloves and safety glasses or goggles when working with hydraulic systems.*

## Protective Equipment

Wear protective clothing and equipment.

Wear clothing and equipment appropriate for the job. Avoid loose fitting clothing.

Because prolonged exposure to loud noise can cause hearing impairment or hearing loss, wear suitable hearing protection.

## Chemical Safety

Agricultural chemicals can be dangerous. Improper use can seriously injure persons, animals, plants, soil & property.

Read chemical manufacture's instructions and store or dispose of unused chemicals as specified. Handle chemicals with care and avoid inhaling smoke from any type of chemical fire.

Store or dispose of unused chemicals as specified by the chemical manufacturer.

## Prepare for Emergencies

Keep a First Aid Kit and Fire Extinguisher handy

Keep emergency numbers for doctor, ambulance, hospital and fire department near phone.

## Tire Safety

Tire changing can be dangerous and should be performed by trained personnel using correct tools and equipment.

When inflating tires, use a clip-on chuck and extension hose long enough to allow you to stand to one side, not in front of or over the tire assembly. Use a safety cage if available.

When removing and installing wheels, use wheel-handling equipment adequate for weight involved.

## Safety Chain

Use a safety chain to help control drawn machinery should it separate from the tractor drawbar.

Use a chain with a strength rating equal to or greater than the gross weight of towed machinery, which is 10,100 pounds minimum in accordance with ASAE S338.2 specifications. If two or more machines are pulled in tandem, a larger chain may be required. Chain capacity must be greater than the TOTAL weight of all towed implements.

A second chain should be used between each implement.

## SAFETY INFORMATION

Attach the chain to the tractor drawbar support or specified anchor location. Allow only enough slack in the chain to permit turning. The distance from hitch pin to attachment point or intermediate support point should not exceed 9 inches. See Figure 1-2.

Replace chain if any links or end fittings are broken, stretched or damaged.

Do not use a safety chain for towing.

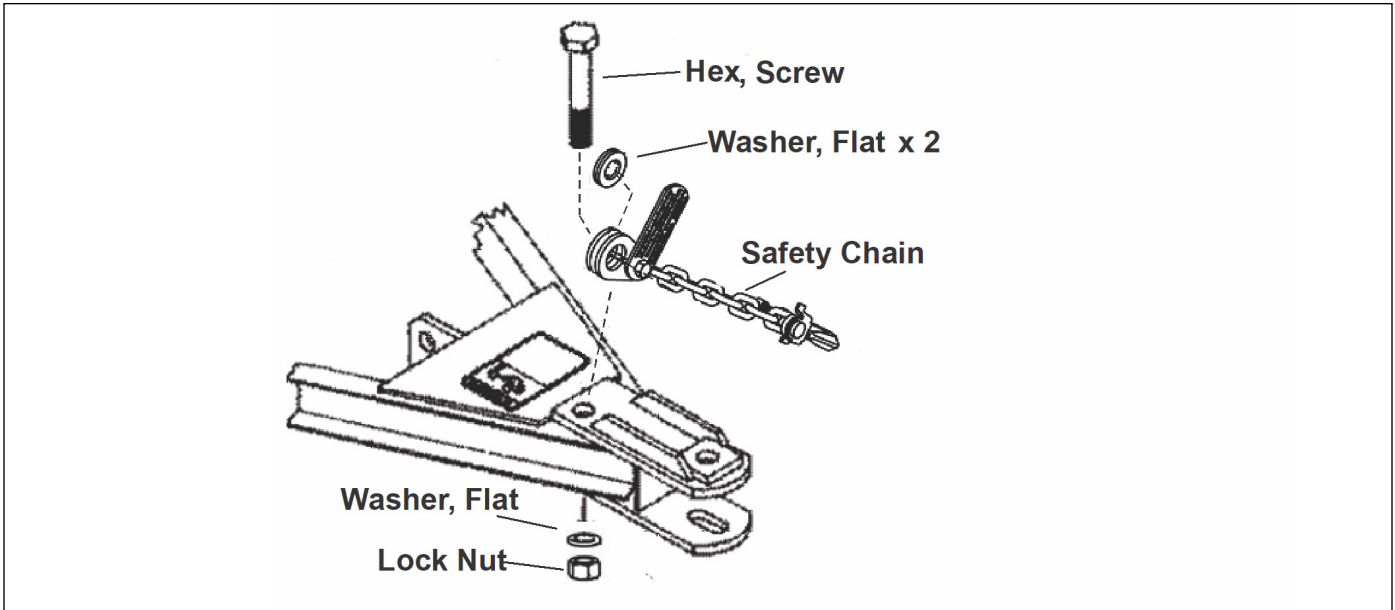

Figure 1-2: Safety Chain Hook-up



# Safety Signs

1 **CAUTION**  
THIS TRANSMISSION BOX  
FOR 540 RPM ONLY!

1 **CAUTION**  
THIS TRANSMISSION BOX  
FOR 1000 RPM ONLY!

2 **IMPORTANT**  
THIS TRANSMISSION BOX  
SHIPPED WITHOUT OIL!  
BEFORE STARTING MACHINE  
ADD OIL **SUMMER** EP140  
240L/HR EP 90

3 **DANGER**  
**ROTATING DRIVE LINE**  
KEEP AWAY!  
KEEP CHILDREN AWAY FROM  
MACHINE UNDER ALL CONDITIONS  
OF OPERATION.  
DO NOT OPERATE MACHINE IN EXCESS OF STATED TRACTOR  
PTO SPEED.  
BE CAREFUL. OBSERVE ALL STANDARD SAFETY PRECAUTIONS.  
BLOCK UP MACHINE BEFORE ATTEMPTING SERVICE UNDER  
MACHINE. DO NOT USE HYDRAULIC CYLINDER TO SUPPORT  
MACHINE WHEN WORKING UNDER IT.

4 **WARNING**  
**THROWN OBJECT HAZARD**  
KEEP AWAY!  
TO PREVENT SERIOUS INJURY OR DEATH  
RE OBJECTS. KEEP AWAY FROM  
DITCHES DURING OPERATION.  
KEEP OTHERS OUT OF VICINITY WHILE  
OPERATING.

5 **WARNING**  
**DO NOT GO NEAR LEAKS**  
High pressure oil leaks can cause  
skin causing serious injury,  
gangrene or death.  
If you feel, see, or smell hydraulic  
oil, immediately stop work and  
notify your supervisor. If you  
are injured, seek emergency medical  
help. Immediate surgery is  
required to remove oil.  
Do not use fingers or skin to  
check for leaks.  
Lower load or relieve hydraulic  
pressure before loosening fittings.  
308174

6 **CAUTION**  
1. OPERATOR MUST REMAIN IN TRACTOR WHILE POWER TAKE OFF  
IS IN MOTION.  
2. NEVER MAKE ADJUSTMENT, LUBRICATE, OR CLEAN MACHINE  
WITH ANY PART OF MACHINE IN MOTION.  
3. DO NOT PERMIT TRACTOR RIDERS OTHER THAN OPERATOR. DO  
NOT ALLOW ANYONE TO RIDE THE MACHINE.  
4. DO NOT OPERATE SPEEDER IN EXCESS OF STATED TRACTOR  
PTO SPEED.  
5. BE CAREFUL. OBSERVE ALL STANDARD SAFETY PRECAUTIONS.  
6. BLOCK UP MACHINE BEFORE ATTEMPTING SERVICE UNDER  
MACHINE. DO NOT USE HYDRAULIC CYLINDER TO SUPPORT  
MACHINE WHEN WORKING UNDER IT.

7 **LUBRICATION INSTRUCTIONS**  
1. GREASE PTO JOINTS AND TELESCOPING SHAFT AND  
TUBE REGULARLY.  
2. GREASE UNIVERSAL JOINT ON CROSS SHAFTS DAILY.  
3. GREASE THE SIX FLANGE BEARINGS AND THE THREE  
BEAR PAIR TUBE BEARINGS EVERY 40 HOURS.  
(THERE IS ONE FLANGE BEARING ON THE OUTER END  
OF EACH CROSS SHAFT AND ONE ON EACH END OF  
THE TUBE END. THE BEARING ON THE INNER  
END OF EACH ROTOR IS MOUNTED ON THE CENTER  
FLANGE OF THE ROTORS.)  
4. REPLACE WHEEL BEARINGS ONCE A YEAR.  
5. CHECK OIL LEVEL IN GEARBOX BEFORE USING.  
MIXTURE OILS WITH PROPER GRADES OF LUB-  
RICANT CHANGE OIL AT THE END OF EACH  
SEASON.

8 **DANGER**  
**ROTATING DRIVE LINE**  
CONTACT CAN CAUSE DEATH  
KEEP AWAY!  
DO NOT OPERATE WITH OUT-  
• ALL DRIVE LINE GUARDS, TRACTOR  
AND EQUIPMENT SHOULD BE IN PLACE  
• DRIVE LINE GUARDS SECURELY  
• ATTACHED AT BOTH ENDS  
• DRIVE LINE GUARDS THAT TURN  
FREELY ON DRIVE LINE.

9

10

11 **PATENT**  
THIS MACHINE PRODUCED  
UNDER ONE OR MORE OF  
THE FOLLOWING PATENTS:  
US 3,070,084 US 3,390,727  
US 3,555,797 US 4,534,416  
US 4,871,030  
CANADA 1,223,476  
80387

12 **Brillion**

13 **Brillion**

1. 5D019 - CAUTION 540RPM ONLY  
2. 9C594 - TRANSMISSION BOX CAUTION  
3. 2J099 - ROTATING DRIVELINE  
4. 4K031 - THROWN OBJECT HAZARD  
5. 3K076 - HYDRAULIC LEAKS WARNING  
6. 5D006 - CAUTION LIST  
7. 8J273 - LUBRICATION INSTRUCTIONS  
8. 3K396 - DANGER, ROTATING DRIVELINE  
9. 2J430 - REFLECTIVE RED  
10. 2J431 - REFLECTIVE AMBER  
11. 8D378 - PATENT  
12. 4K036 - "BRILLION" 2 3/4" X 20"  
13. 4K039 - "BRILLION" 3 3/4" X 40"

Figure 1-3: Safety Signs and Decals (1 of 2)

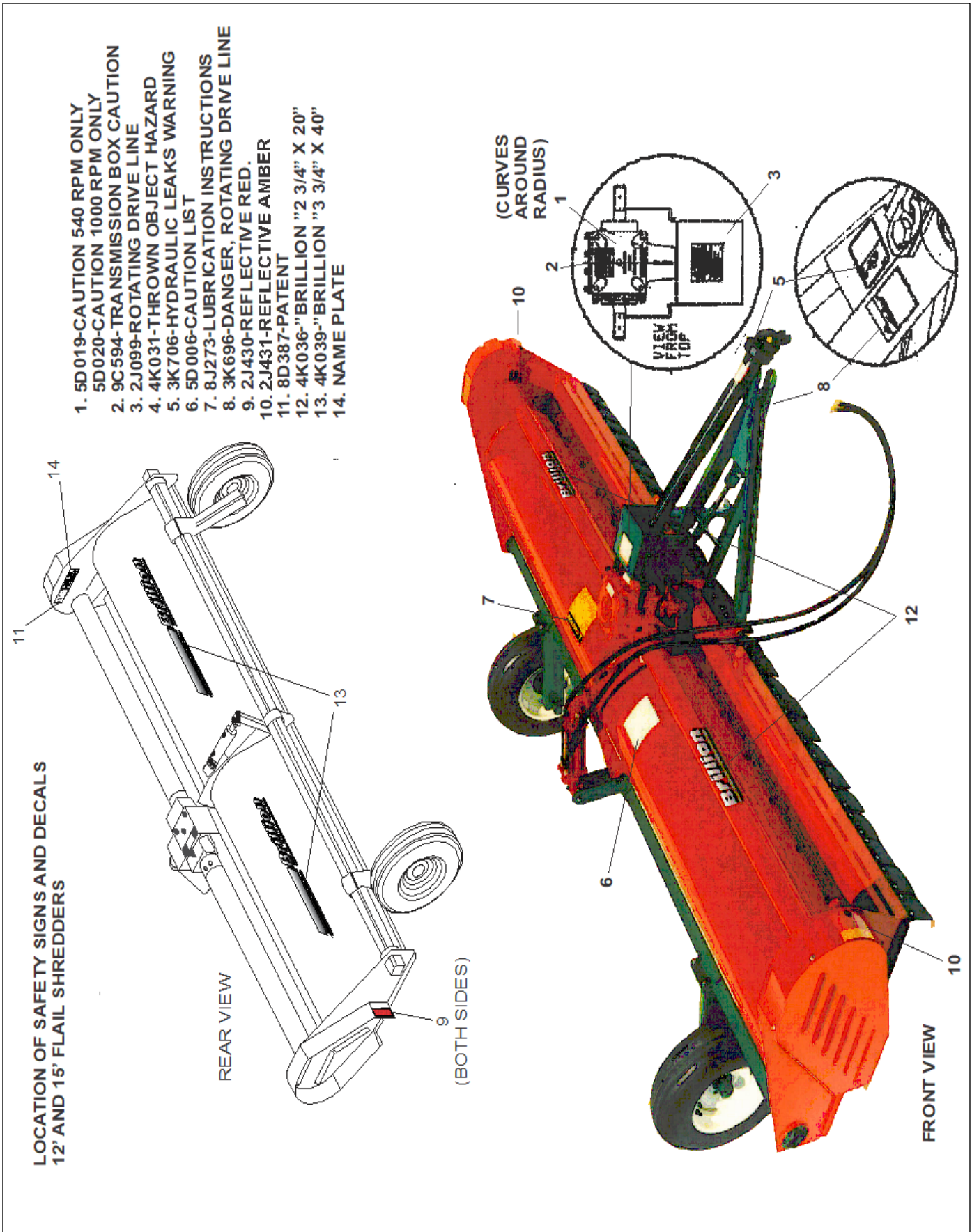

**Figure 1-4: Safety Signs and Decals (2 of 2)**

## Assembly Instructions

### Tires and Wheels

1. Mount tires on wheels. (Tires are not furnished with the machine). Use 9.5L-15 6-ply tires. Inflate to 20 psi.
2. Raise machine high enough to install screw jack at front of machine. Set front of machine approximately 1 foot high.
3. Mount tail wheel arms on 3- square rear axle tube. Arms are normally installed with the wheels toward the outside of the machine, but may be reversed depending upon wheel spacing desired.
4. Use the widest possible wheel spacing for machine stability.

Mount wheels on hubs.

#### NOTE

The view below shows 15 foot machine. On 12 foot machines, spindles are welded to wheel arms.

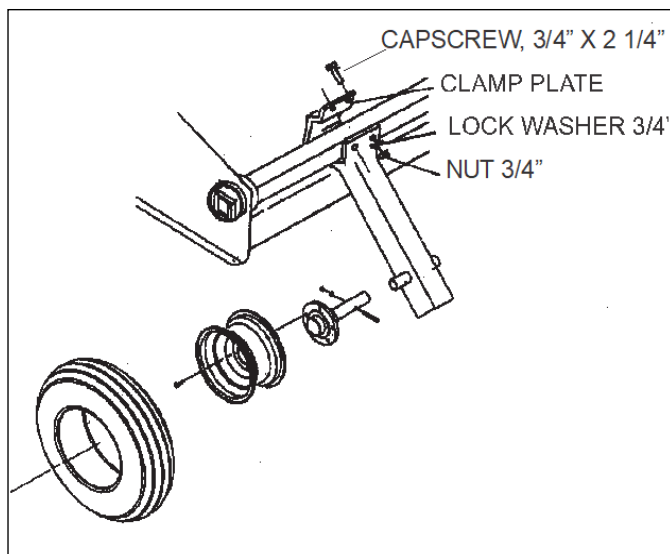

Figure 2-1: Tail Wheel Arms



Figure 2-2: Wheel Mounting

### Belts

- Install belts and tighten: Tighten belts by loosening mounting bolts on gearbox base and upper pulley bearings, turn adjusting screws. Move both gearbox and shaft bearings equally to maintain alignment between pulleys and gearbox.
- See Figures 4-2 and 4-3 for proper belt tension and pulley alignment.

#### NOTE

To check alignment of pulleys and gearbox visually, sight along drive shaft shields using front of machine as a reference line.

## Hitch

1. Attach front hitch, with slotted clevis plate down, to front of frame with 1" diameter clevis pins.
2. Attach two drawbar links to the lower holes on both front hitch and shredder frame, using the remaining clevis pins. See Figure 2-3. Do not operate the machine unless the drawbar links are installed.

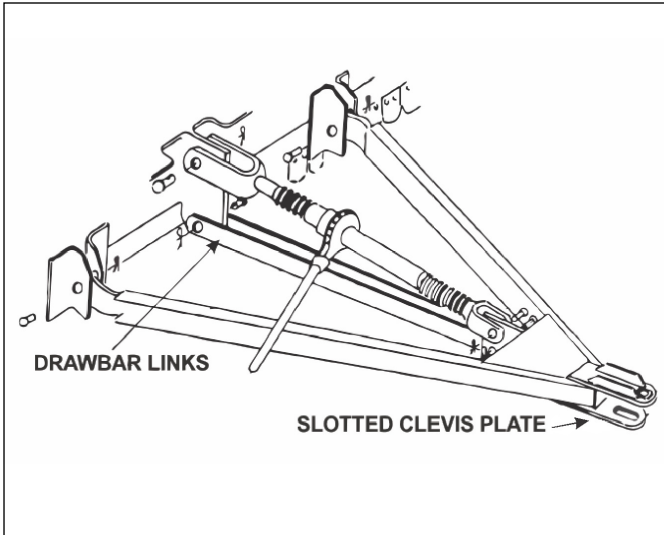

Figure 2-3: Drawbar Links

3. Attach the implement end of the telescoping drive line to the gearbox, insert the 3/16" and 5/16" roll pins. *Ensure that the slots in the pins are offset and do not line up.* Replace the grease fittings.
4. The pins must be centered in the input shaft to permit rotation of the O/R Clutch. insert bolt and tighten locknut.
5. Lubricate the telescoping section of the drive line by compressing completely to expose the lube fitting through the holes in the shield.

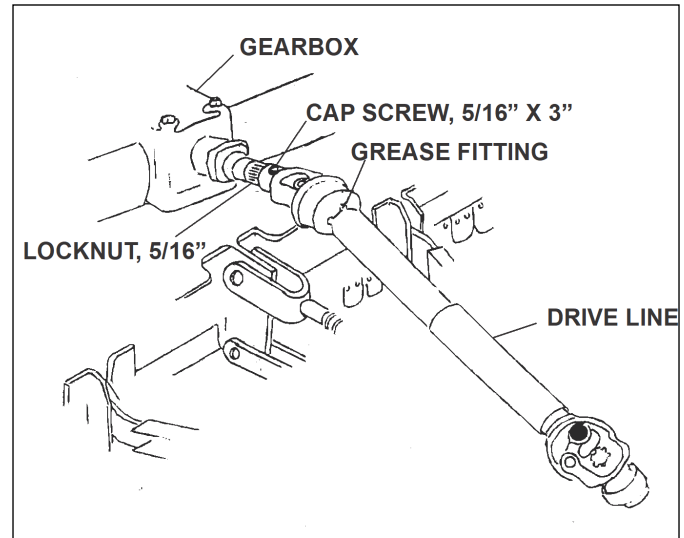

Figure 2-4: Driveline

### IMPORTANT

The machine is shipped with no grease in the gearbox. On the side of the gearbox you will find a plug located in front of the output shaft. Fill to the bottom of the plug hole with the proper lubricant. Use SAE 140 EP when the temperature is above 32 degrees, and SAE 90 EP when the temperature is below 32 degrees. Do not overfill with lubricant. See Figure 2-5.

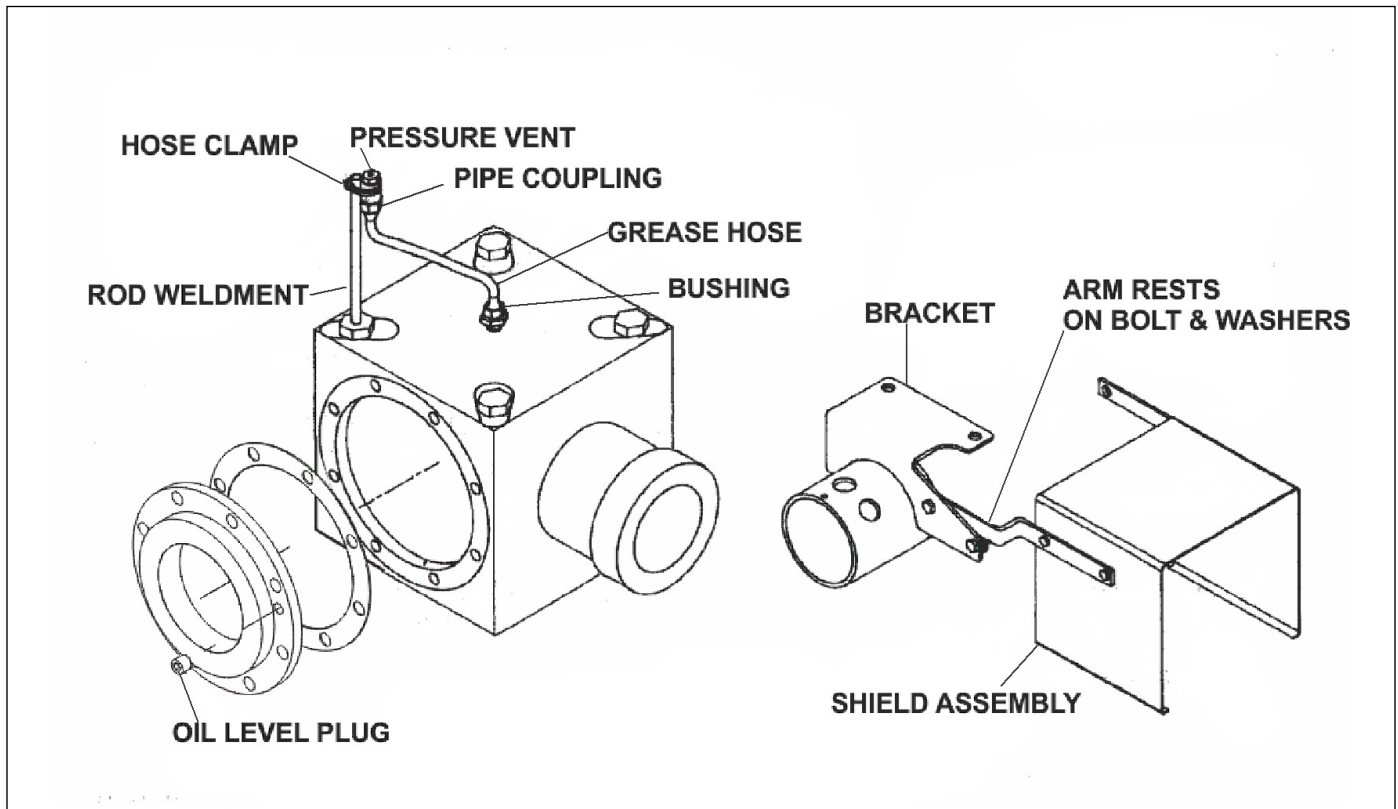

Figure 2-5: Gearbox

- To install skirts, insert the end of the rod with the holes in it through the first (outer) lug. Next slide on two skirts. When the rod is all the way in, put a cotter pin in the hole in the end of the rod.
- Install handle in turnbuckle. Install the turnbuckle in the upper holes of the hitch and shredder frame using the pins provided.
- Assemble the base of the hydraulic cylinder to the lug on the top of the shredder housing. Place the rod end clevis between the lift arms of the transport axle and secure with the pin provided. See Figure 2-6. (The distance between pin centers should be set at 28 1/4" with the cylinder fully extended).
- Assemble hose support for hydraulic hoses. Insert hose support into mounting tube at the center of the machine and fasten in place with cotter pin provided.
- Remove pressure vent from gearbox. Reassemble vent and extension components. See Figure 2-5. (If machine is operated with pressure vent mounted directly into the box, a small amount of lubricant might leak from the breather plug).
- Assemble the Shield Assembly to the Brackets which are mounted on top of the gearbox.

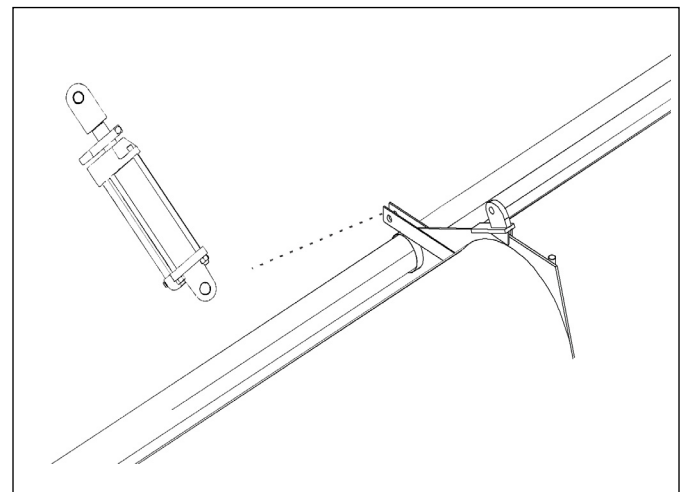

Figure 2-6: Hydraulic Cylinder

Page Intentionally Blank

# Chapter 3

## Operation

---

This chapter will cover the basic operation and procedures for the Landoll Brillion Flail Shredder. Be sure to read and understand the Safety Procedures and Cautions starting on page 1-1.

### Tractor Preparation

1. Make sure tractor drawbar hitch hole is positioned correctly for the power take-off speed to be used.
2. 540 RPM 1-3/8 6 spline: 14" end of PTO shaft to hole center.
3. 1000 RPM 1-3/8 21 spline: 16" end of PTO shaft to hole center.
4. Center PTO shaft to top of drawbar: 8" preferred, 6" minimum, 12" maximum.
5. Make sure tractor power take-off master shield is in place.

### Shredder Operation

- Run shredder at its rated RPM. Decal on gearbox shows proper speed, either 540 or 1000 RPM.
- Check to make sure drain plug on gear box is tight.

### Transport Lock

- To prepare machine for transport, raise it fully and assemble lock pin and spacers as shown in view at right. (A spacer on each end of pin, held in place with roll pin and hairpin cotter).
- When in field position, pin and spacers can be stored in center plate storage hole, just ahead of hydraulic cylinder.

### IMPORTANT

- **When operating shredder, maintain ground clearance (2" recommended minimum) on flail knives. If hydraulic cylinder has a stroke control on it, adjust the stop to provide proper cutting height.**
- **Do not make sharp turns when machine is running. Turning too short will cause vibration and may result in damage to the implement drive line universal joints and to the machine.**
- **It is advisable to skip 8 or 12 rows when turning around at the end of the field. If tractor is equipped with an overriding or free turning PTO shaft, it is advisable to disengage PTO when turning.**
- **When changing cutting height, adjust the turnbuckle on the hitch to keep the machine as level as possible. Attach the screw jack to the front of the shredder frame and use it to raise and lower the machine to relieve load on the turnbuckle while adjusting.**
- **Store the screw jack on the top position, out of the way, when not in use.**
- **Never operate machine without a full set of knives. If one knife assembly is replaced with a new one, the closest one, 180 degree opposite must also be replaced with a new one. See Figure 3-1.**



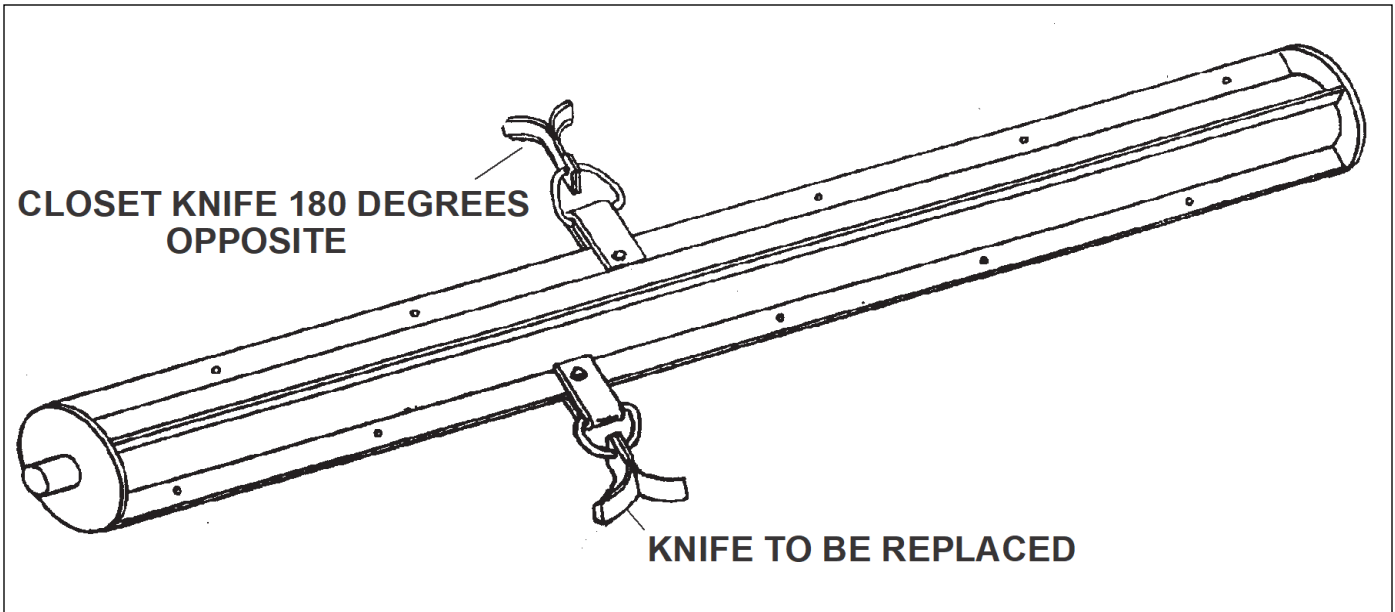

Figure 3-1: Knife 180 Degree Opposite

### Safety Chain

Use of a safety chain is recommended if the machine is towed on a public road or highway. Chain should be rated at 10,100 pounds minimum in accordance with ASAE S338 specifications. Slack in the chain should only be enough to permit turning. Distance from the hitch pin to the attachment point or intermediate support should not exceed 9 inches.

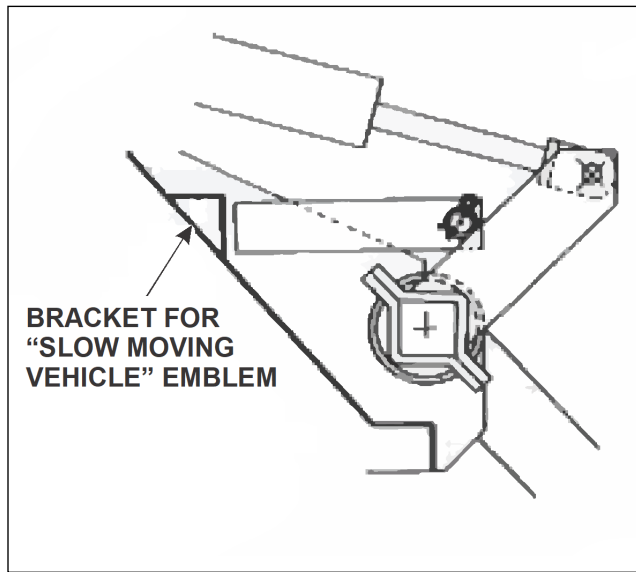

Figure 3-2: Transport Lock

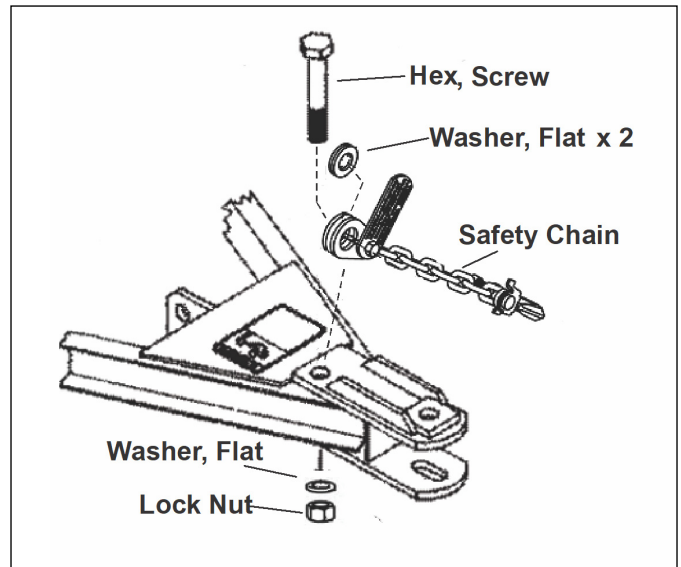

Figure 3-3: Safety Chain







## Preventive Maintenance & Adjustment

### Fasteners

Before operating your Brillion machine, check all hardware for tightness. Use the Tightening Torque Table reproduced below as a guide. See Table 4-1

After a few hours of use, check entire machine and tighten any loose nuts or bolts. Daily or periodic checks should be made thereafter.

**Table 4-1: Torque Tightening Table**

<b>BOLT/NUT TIGHTENING TORQUES</b> For Fine Threads Multiply Chart Values by 1.1					
Thread Size	Bolt Grade			Plated, Stover Lock Nuts	
	GRADE 2	GRADE 5	GRADE 8	GRADE B	GRADE C
					
				MIN/MAX	MIN/MAX
1/4-20	5	8	12	5/7	7/10
5/16-18	11	17	24	10/12	11/16
3/8-16	20	30	45	15/20	20/28
7/16-14	30	50	70	23/32	31/43
1/2-13	50	75	105	37/50	45/62
9/16-12	70	110	155	50/70	70/95
5/8-11	100	150	210	70/95	90/122
3/4-10	170	270	375	125/165	155/210
7/8-9	165	430	610	275/375	360/462
1-8	250	645	910		
1 1/8-7	355	795	1290		
1 1/4-7	500	1120	1820		
1 3/8-6	745	1670	2710		
1 1/2-6	870	1950	3160		

- Values are given in foot-pounds.
- Use GRADE B lock nuts with GRADE 2 and GRADE 5 bolts only.
- Use GRADE C lock nuts with GRADE 8 bolts only.

## Lubrication

- Check oil level in gearbox before using. On the side of the gearbox are two plugs. Fill and maintain to lower level plug with proper grade of lubricant. Where temperatures are above 32° F. (0° C.) use SAE Grade 140EP. In temperatures below 32° F. (0° C.) use SAE Grade 90EP.
- Grease the implement drive assembly including the universal joint crosses and the telescoping tube and shaft. Compress the two halves of the drive line exposing the fitting. Do this daily.
- Grease other bearings lightly every 40 to 50 hours of operation. It is necessary to block up the machine and get underneath the machine to grease the two center bearings on the flail assembly.
- Block the wheels to prevent the machine from moving.
- Repack wheel bearings once a year.

## To Check Pulley Alignment

Lay straight edge against both pulleys. Straight edge should touch on both edges of each pulley. It may be necessary to slide the pulley in or out on the shaft, as well as move the gear box to properly align the belts.

It is important to maintain pulley alignment for normal belt life. See Figure 4-2.

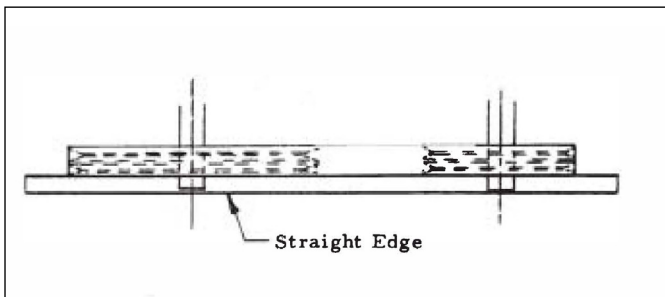

Figure 4-2: Pulley Alignment

## Belt Tension On Models With Multiple “C” Section Belts

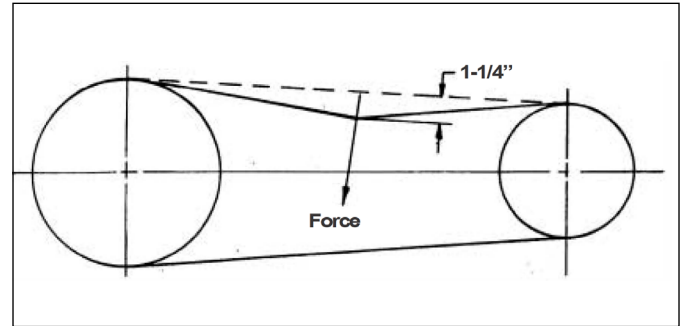

Figure 4-3: Belt Tension

Using a spring scale at right angles to the center of the span, apply force to one belt large enough to deflect the belt 1-1/4". See Figure 4-3.

1. The force required should be about 20 lbs. For a new belt that is being tightened for the first time the force required for 1-1/4" deflection should be 30 lbs.
2. At the end of 2-4 hours of operation the belts should be retightened to the normal tension.
3. After 24-48 hours the belt tension should be rechecked. Either too high or too low belt tension will shorten belt life.

Check belt tension and alignment frequently. New belts stretch rapidly in the first few hours of use.

Check tire inflation pressures at least once a week. Maximum pressure 20 psi; minimum pressure 10 psi.

## Cutting Blades

Check for blade breakage if there seems to be excessive vibration. Replace any broken blades in pairs.

### IMPORTANT

**Never operate machine without a full set of knives. If one knife assembly is replaced with a new one, the closest one, 180 degree opposite must also be replaced with a new one.**

The retainers on all the knives on one cylinder must all be installed on the same side of the bar. See Figure 4-4. It shows the correct location of the retainers used to keep to keep the “D” ring from turning over.

Both styles of cutting knives are shown. See Figure 4-5.

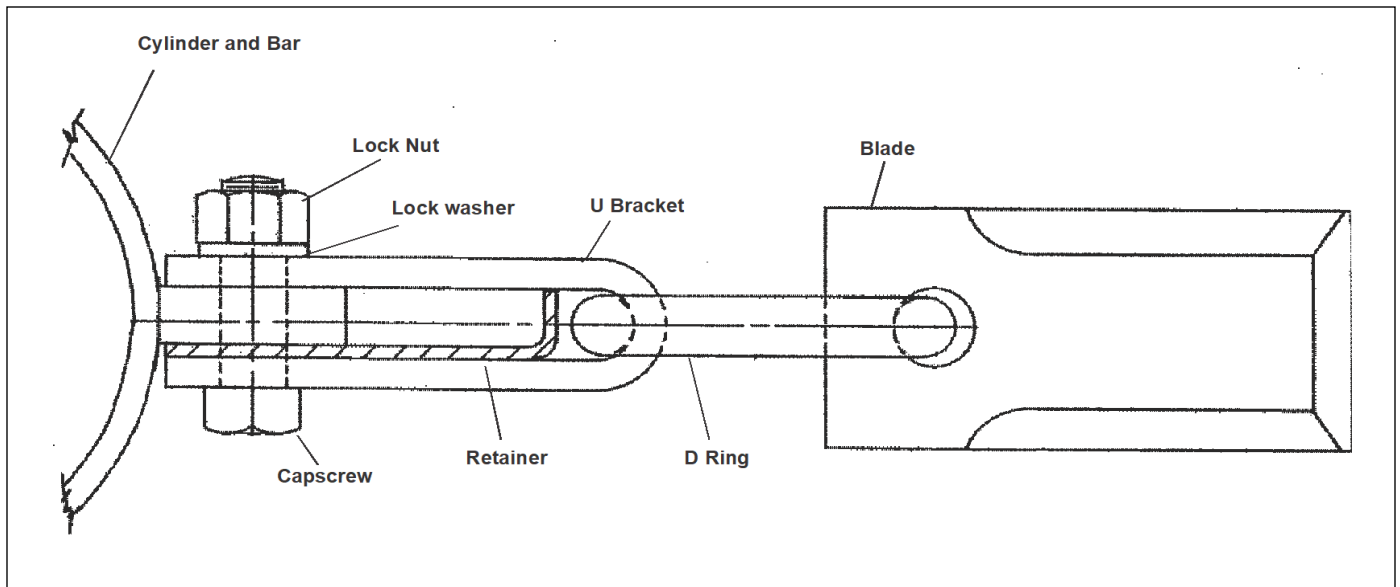

Figure 4-4: Retainer Placement

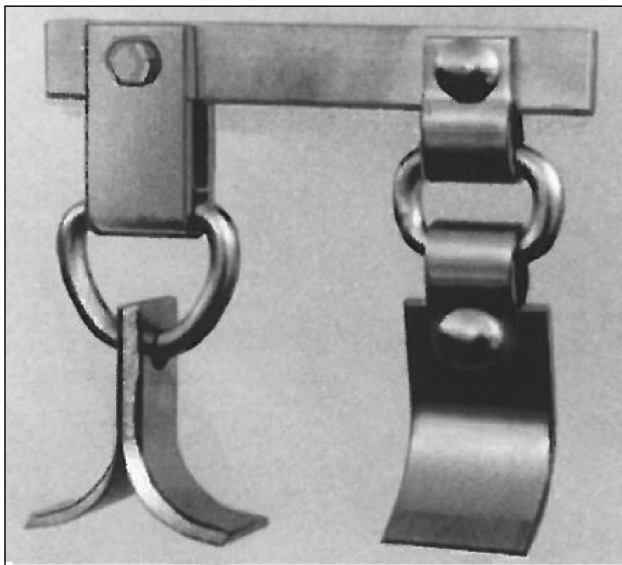

Figure 4-5 Both Styles of Cutting Knives

Page Intentionally Blank

## General Reference Tables and Specifications

**Table 5-1: Model Specifications**

	<b>FS-1446</b>	<b>FS-1446-1</b>	<b>FSC-1446</b>	<b>FSC-1446-1</b>
<b>Approximate Weight</b>	2,511 lbs. (1,130 kg)	2,511 lbs. (1,130 kg)	2,511 lbs. (1,130 kg)	2,511 lbs. (1,130 kg)
<b>Working Width</b>	12 ft. 0 in. (3.6 m)	12 ft. 0 in. (3.6 m)	12 ft. 0 in. (3.6 m)	12 ft. 0 in. (3.6 m)
<b>Transport Width</b>	13 ft. 1 in. (3.93 m)	13 ft. 1 in. (3.93 m)	13 ft. 1 in. (3.93 m)	13 ft. 1 in. (3.93 m)
<b>Transport Height</b>	Dependent on Tractor Hitch Position	Dependent on Tractor Hitch Position	Dependent on Tractor Hitch Position	Dependent on Tractor Hitch Position
<b>Overall Length</b>	9 ft. 8 in. (2.9 m)	9 ft. 8 in. (2.9 m)	9 ft. 8 in. (2.9 m)	9 ft. 8 in. (2.9 m)
<b>Drive Line</b>	540 RPM	1000 RPM	540 RPM	540 RPM
<b>Gear Box</b>	180 HP (138.24 kW)	180 HP (138.24 kW)	180 HP (138.24 kW)	180 HP (138.24 kW)
<b>Over Running Clutch</b>	Standard	Standard	Standard	Standard
<b>Constant Velocity PTO Shaft</b>	NA	Standard	NA	Standard
<b>Knife Type</b>	Side Slicer	Side Slicer	Cup Type	Cup Type
<b>Hitch</b>	Pull-Type with Hydraulic Lift	Pull-Type with Hydraulic Lift	Pull-Type with Hydraulic Lift	Pull-Type with Hydraulic Lift
<b>Tire Size (Set of 2 Standard)</b>	9.5L x 15-6 ply Implement Rib	9.5L x 15-6 ply Implement Rib	9.5L x 15-6 ply Implement Rib	9.5L x 15-6 ply Implement Rib
<b>Auxiliary Wheel Kit (1 Wheel Package)</b>	Optional	Optional	Optional	Optional
<b>Center Cut Kit</b>	Optional	Optional	Optional	Optional
<b>Hydraulic Cylinder</b>	Optional	Optional	Optional	Optional
<b>Cylinder Hose Kit</b>	Optional	Optional	Optional	Optional
<b>Safety Chain</b>	Optional	Optional	Optional	Optional
<b>Horsepower</b>	5 to 10 HP per ft.	5 to 10 HP per ft.	5 to 10 HP per ft.	5 to 10 HP per ft.
<b>Recommended Operating Speed</b>	3 to 6 MPH (5 to 10 km/h)	3 to 6 MPH (5 to 10 km/h)	3 to 6 MPH (5 to 10 km/h)	3 to 6 MPH (5 to 10 km/h)

## GENERAL REFERENCE TABLES AND SPECIFICATIONS

	FSB-1446	FSB-1446-1	FS-1806	FS-1806-1
<b>Approximate Weight</b>	2,511 lbs. (1,130 kg)	2,511 lbs. (1,130 kg)	2,833 lbs. (1,275 kg)	2,833 lbs. (1,275 kg)
<b>Working Width</b>	12 ft. 0 in. (3.6 m)	12 ft. 0 in. (3.6 m)	15 ft. 0 in. (4.5 m)	15 ft. 0 in. (4.5 m)
<b>Transport Width</b>	13 ft. 1 in. (3.93 m)	13 ft. 1 in. (3.93 m)	16 ft. 1 in. (4.83 m)	16 ft. 1 in. (4.83 m)
<b>Transport Height</b>	Dependent on Tractor Hitch Position	Dependent on Tractor Hitch Position	Dependent on Tractor Hitch Position	Dependent on Tractor Hitch Position
<b>Overall Length</b>	9 ft. 8 in. (2.9 m)	9 ft. 8 in. (2.9 m)	9 ft. 8 in. (2.9 m)	9 ft. 8 in. (2.9 m)
<b>Drive Line</b>	540 RPM	1000 RPM	540 RPM	1000 RPM
<b>Gear Box</b>	180 HP (138.24 kW)	180 HP (138.24 kW)	180 HP (138.24 kW)	180 HP (138.24 kW)
<b>Over Running Clutch</b>	Standard	Standard	Standard	Standard
<b>Constant Velocity PTO Shaft</b>	NA	Standard	NA	Standard
<b>Knife Type</b>	Combination	Combination	Side Slicer	Side Slicer
<b>Hitch</b>	Pull-Type with Hydraulic Lift	Pull-Type with Hydraulic Lift	Pull-Type with Hydraulic Lift	Pull-Type with Hydraulic Lift
<b>Tire Size (Set of 2 Standard)</b>	9.5L x 15-6 ply Implement Rib	9.5L x 15-6 ply Implement Rib	9.5L x 15-6 ply Implement Rib	9.5L x 15-6 ply Implement Rib
<b>Auxiliary Wheel Kit (1 Wheel Package)</b>	Optional	Optional	Optional	Optional
<b>Center Cut Kit</b>	Optional	Optional	Optional	Optional
<b>Hydraulic Cylinder</b>	Optional	Optional	Optional	Optional
<b>Cylinder Hose Kit</b>	Optional	Optional	Optional	Optional
<b>Safety Chain</b>	Optional	Optional	Optional	Optional
<b>Horsepower</b>	5 to 10 HP per ft.	5 to 10 HP per ft.	5 to 10 HP per ft.	5 to 10 HP per ft.
<b>Recommended Operating Speed</b>	3 to 6 MPH (5 to 10 km/h)	3 to 6 MPH (5 to 10 km/h)	3 to 6 MPH (5 to 10 km/h)	3 to 6 MPH (5 to 10 km/h)

**GENERAL REFERENCE TABLES AND SPECIFICATIONS**

	FSC-1806	FSC-1806-1	FSB-1806	FSB-1806-1
<b>Approximate Weight</b>	2,833 lbs. (1,275 kg)	2,833 lbs. (1,275 kg)	2,833 lbs. (1,275 kg)	2,833 lbs. (1,275 kg)
<b>Working Width</b>	15 ft. 0 in. (4.5 m)	15 ft. 0 in. (4.5 m)	15 ft. 0 in. (4.5 m)	15 ft. 0 in. (4.5 m)
<b>Transport Width</b>	16 ft. 1 in. (4.83 m)	16 ft. 1 in. (4.83 m)	16 ft. 1 in. (4.83 m)	16 ft. 1 in. (4.83 m)
<b>Transport Height</b>	Dependent on Tractor Hitch Position	Dependent on Tractor Hitch Position	Dependent on Tractor Hitch Position	Dependent on Tractor Hitch Position
<b>Overall Length</b>	9 ft. 8 in. (2.9 m)	9 ft. 8 in. (2.9 m)	9 ft. 8 in. (2.9 m)	9 ft. 8 in. (2.9 m)
<b>Drive Line</b>	540 RPM	1000 RPM	540 RPM	1000 RPM
<b>Gear Box</b>	180 HP (138.24 kW)	180 HP (138.24 kW)	180 HP (138.24 kW)	180 HP (138.24 kW)
<b>Over Running Clutch</b>	Standard	Standard	Standard	Standard
<b>Constant Velocity PTO Shaft</b>	NA	Standard	NA	Standard
<b>Knife Type</b>	Cup Type	Cup Type	Combination	Combination
<b>Hitch</b>	Pull-Type with Hydraulic Lift	Pull-Type with Hydraulic Lift	Pull-Type with Hydraulic Lift	Pull-Type with Hydraulic Lift
<b>Tire Size (Set of 2 Standard)</b>	9.5L x 15-6 ply Implement Rib	9.5L x 15-6 ply Implement Rib	9.5L x 15-6 ply Implement Rib	9.5L x 15-6 ply Implement Rib
<b>Auxiliary Wheel Kit (1 Wheel Package)</b>	Optional	Optional	Optional	Optional
<b>Center Cut Kit</b>	Optional	Optional	Optional	Optional
<b>Hydraulic Cylinder</b>	Optional	Optional	Optional	Optional
<b>Cylinder Hose Kit</b>	Optional	Optional	Optional	Optional
<b>Safety Chain</b>	Optional	Optional	Optional	Optional
<b>Horsepower</b>	5 to 10 HP per ft.	5 to 10 HP per ft.	5 to 10 HP per ft.	5 to 10 HP per ft.
<b>Recommended Operating Speed</b>	3 to 6 MPH (5 to 10 km/h)	3 to 6 MPH (5 to 10 km/h)	3 to 6 MPH (5 to 10 km/h)	3 to 6 MPH (5 to 10 km/h)





**Document Control Revision Log:**

Date	Revision	Improvement(s) Description and Comments
7/7/2008	205rev7-7-08	Initial Release
9/2011	987rev0911	Updated
nn/nn/nn		



**Intertek**

Equipment from Landoll Company, LLC is built to exacting standards ensured by ISO 9001 registration at all Landoll manufacturing facilities.

**Flail Shredder  
Models - 1446 and 1806  
Series - FS, FSC and FSB  
Operator's Manual**

**Re-Order Part Number 8J306 987rev0911**

**LANDOLL COMPANY, LLC**

1900 North Street

Marysville, Kansas 66508

(785) 562-5381

**800-428-5655 ~ WWW.LANDOLL.COM**



Copyright 2020. Landoll Company, LLC

"All rights reserved, including the right to reproduce this material or portions thereof in any form"