



**Flail Shredder 12 and 15 ft**  
**Models - 1446, 1446-1, 1806, and 1806-1**  
**Series - FS, FSC, and FSB**  
**Parts Manual**



**LANDOLL COMPANY, LLC**

1900 North Street  
Marysville, Kansas 66508  
(785) 562-5381

**800-428-5655 ~ WWW.LANDOLL.COM**



# Table of Contents

---

## 1 Illustrated Parts List

<b>Instructions for Ordering Parts</b> .....	<b>1-1</b>
Decals .....	1-2
Driveline to Frame Assembly .....	1-4
Wear Plate - 01/25/2008 and Prior .....	1-6
Drawbar .....	1-8
Rotor to Frame Assembly .....	1-10
Rotor Assemblies, Slice and Cup, Left Hand .....	1-12
Rotor Assemblies, Slice and Cup, Right Hand .....	1-13
Rotor Assemblies, Cup, Left Hand .....	1-14
Rotor Assemblies, Cup, Right Hand .....	1-15
Rotor Assemblies, Slice .....	1-16
Knife Assembly, Cup .....	1-17
Knife Assembly, Slice .....	1-18
Center Cut Kit - Optional .....	1-19
PTO Guard .....	1-20
Gearbox Assembly, 540 RPM .....	1-22
Gearbox Assembly, 1000 RPM .....	1-24
PTO Assembly, 1000 RPM - Shredder Serial Number 202950 and Lower .....	1-26
PTO Assembly, 1000 RPM - Shredder Serial Number 202951 and Higher .....	1-28
PTO Assembly, 540 RPM .....	1-30
Hydraulic Components .....	1-32
Pulley Guards .....	1-34
Wheel Arm Assembly .....	1-36
Hub and Spindle Assembly .....	1-37
Wheel and Tire Assembly .....	1-38
Wheel Kit, Auxiliary - Optional .....	1-39
Warning Lights - 07/31/2013 and Prior .....	1-40
Warning Lights - 08/01/2013 and After .....	1-42
Hydraulic Cylinder, 3" X 8 - Cross .....	1-44
Hydraulic Cylinder, 3" X 8 - Prince .....	1-46

## 2 Numerical Index

## 3 Glossary



## Illustrated Parts List

### Instructions for Ordering Parts

**\*\* Repair parts must be ordered through an authorized dealer \*\***

#### DEALER INSTRUCTIONS FOR ORDERING PARTS FROM LANDOLL PARTS DISTRIBUTION CENTER

PHONE #: 800-423-4320 OR 785-562-5381

FAX #: 888-527-3909

ORDER ONLINE: [Dealer.landoll.com](http://Dealer.landoll.com)

#### IDENTIFICATION PLATE

See Figure 1-1 for the Identification Plate, which lists the model and serial number of the equipment. It is located on the right side of the Flail Shredder.

#### SERIAL NUMBER NOMENCLATURE

The serial number for the Flail Shredder is located on the identification plate. The following information will help decode the Landoll serial number.

**FLD2000100 = xxmysssss**

<b>xx</b>	= model series (i.e. "FL" for all Flail Shredders)
<b>m</b>	= month of manufacture (ex. "D" means April. The letter "I" is not used.)
<b>yy</b>	= year manufactured (ex. "20" means 2020)
<b>sssss</b>	= Sequential number used to track warranty and service information.

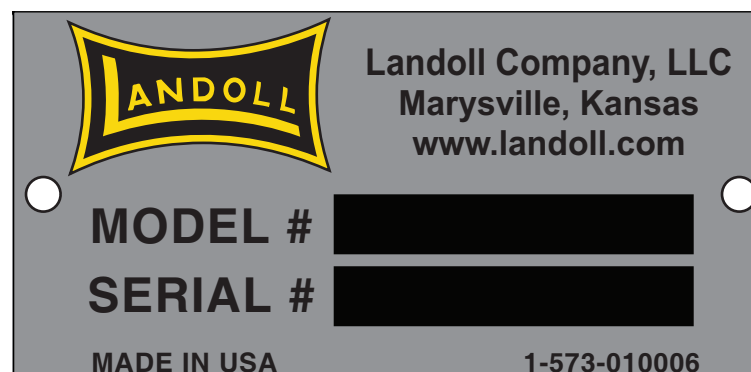

Figure 1-1: Identification Plate

# ILLUSTRATED PARTS LIST

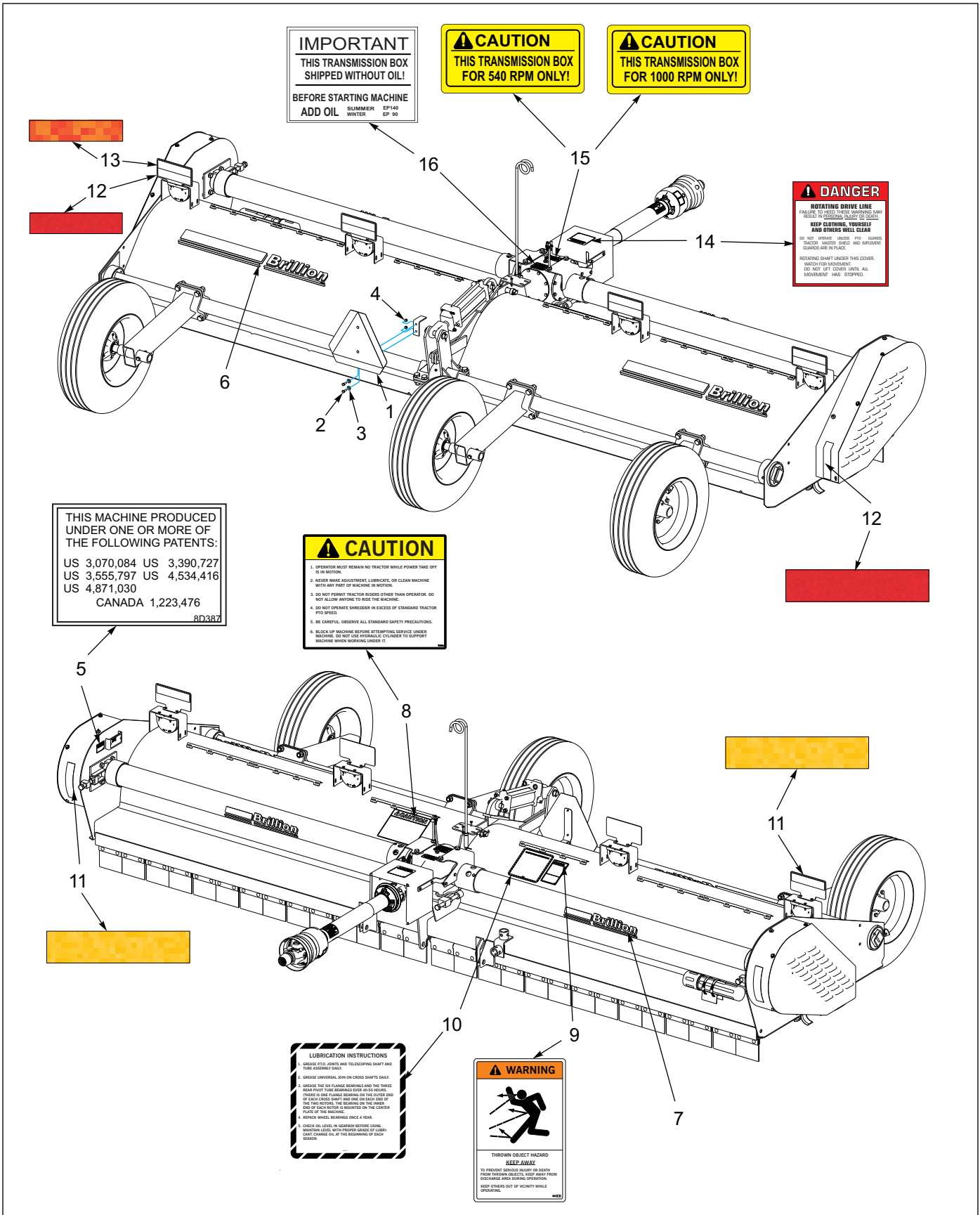

Figure 1-2: Decals

## Decals

ITEM	PART NUMBER	DESCRIPTION	QTY
1	2P151	SMV W/BRACKET	1
2	1-654-010049-05	SCREW, HX CP 5/16-18UNC X 1, GR5	2
3	1-861-010032-09	WASHER, FLAT 5/16 W ZP/CD	2
4	104032	NUT, HX SLF-LKG W/MYL 5/16-18	2
5	8D387	"PATENT" DECAL	1
6	4K039	DECAL-BRILLION (3 1/2 X 40)	2
7	4K036	DECAL-BRILLION (2 3/4 X 20)	2
8	5D006	"CAUTION" DECAL	1
9	4K031	DECAL-THROWN OBJECTS WARNING	1
10	8J273	"LUBE" DECAL	1
11	528934	REFLECTOR - YELLOW	4
12	528933	REFLECTOR - RED ( <b>BOTTOM</b> )	6
13	528938	STRIPE, ORANGE ( <b>TOP</b> )	4
14	2J099	"DANGER" DECAL	1
15	5D019	DECAL - CAUTION ( <b>540 RPM</b> )	1
15	5D020	"CAUTION" DECAL ( <b>1000 RPM</b> )	1
16	9C594	LUBE STICKER	1

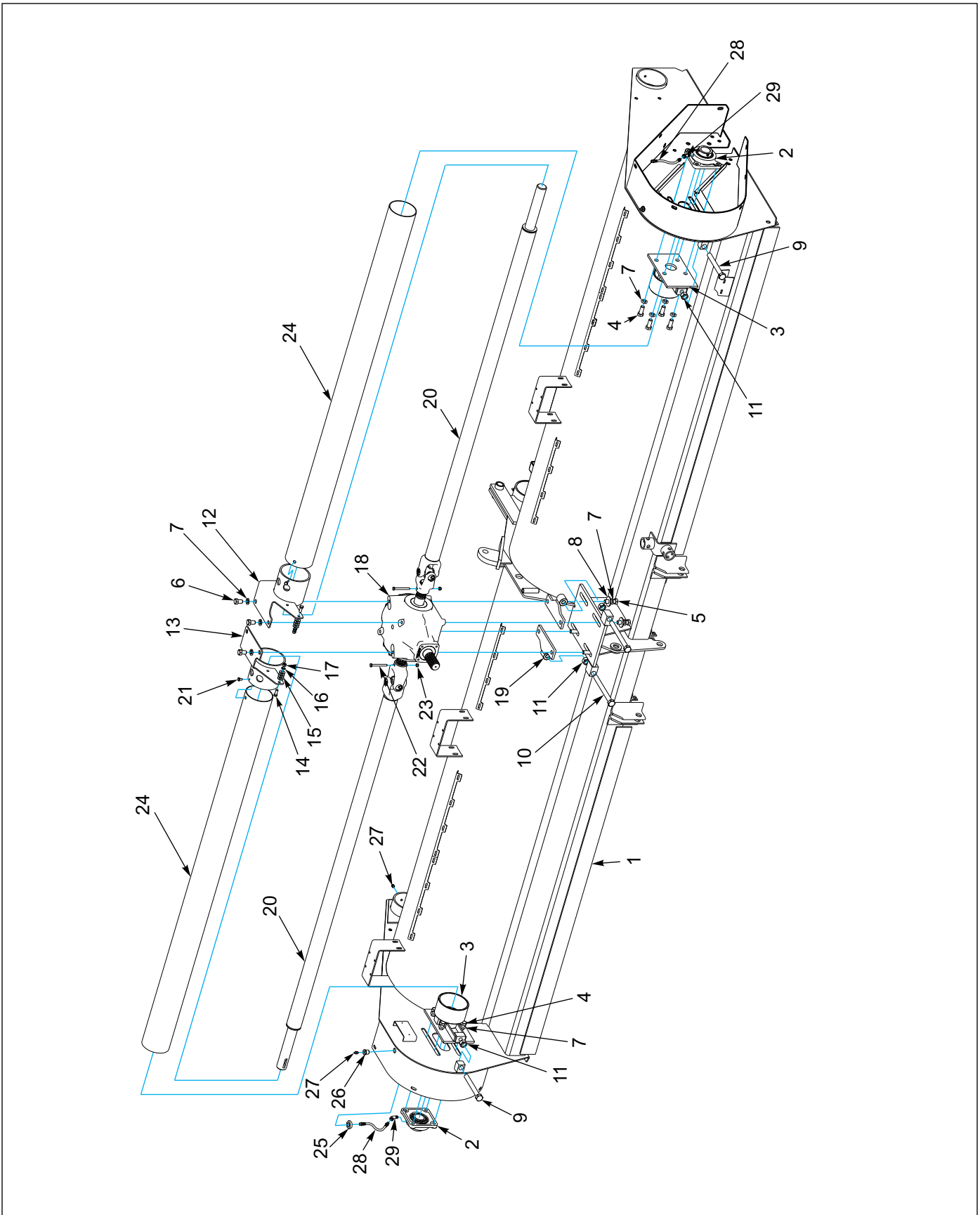

Figure 1-3: Driveline to Frame Assembly



## Driveline to Frame Assembly

ITEM	PART NUMBER	DESCRIPTION	QUANTITY	
			12'	15'
1	3K644	MAIN FRAME - 12' FLAIL	1	
1	3K664	MAIN FRAME - 15' FLAIL		1
2	1K308	BEARING ASSEMBLY ( <b>FLANGE BEARING - 1 3/4 TAP</b> )	2	2
3	8J220	BELT ADJ PLATE WLDMT	2	2
4	1-654-010059-03	SCREW, 5/8-11UNC X 1-1/2 HXCP, G5	8	8
5	1-654-010059-05	SCREW, HEX CAP, 5/8-11UNC X 2, GR5	4	4
6	1-654-010059-01	SCREW, HX CP, 5/8-11UNC X 1, GR5	4	4
7	1-861-010034-15	WASHER, LKG, HLCL SPR, 5 /8	16	16
8	1-861-010032-19	WASHER, FLAT 5/8W, ZP/CD	4	4
9	5D410	HHCS (3/4-10 X 6-1/2 GR2, ZP)	2	2
10	5D411	HHCS (3/4-10 X 8 GR2, ZP)	2	2
11	1-512-010007-12	NUT, HEX 3/4-10 GR2, ZP	4	4
12	3K079	LH BRACKET	1	1
13	3K080	RH BRACKET	1	1
14	1-654-010051-05	SCREW, HEX CAP 3/8-16UNC X 1, GR5	2	2
15	1-861-010032-11	WASHER, FLAT 3/8 W ZP/CD	8	8
16	1-861-010034-11	WASHER, LKG HLCL SPR, 3/8	2	2
17	1-512-010007-07	NUT, HEX 3/8-16, ZP	2	2
18	3K099	1000 RPM BOX ASSEMBLY	1	1
18	3K098	540 RPM GEARBOX ASSEMBLY	1	1
19	3K648	GEARBOX ADJ. WELDMENT	2	2
20	7D216	DRIVE SHAFT ASSEMBLY ( <b>INCLUDES ITEM 22</b> )	2	
20	7D213	DRIVE SHAFT ( <b>INCLUDES ITEM 22</b> )		2
21	1-654-010049-01	SCREW, HEX CAP, 5/16-18UNC X 1/2	2	2
22	103464	SCREW, HEX CAP 5/16-18UNC X 3, GR5	2	2
23	104032	NUT, HX SLF-LKG W/MYL 5/16-18	2	2
24	8J223	SHIELD TUBE	2	
24	8J266	SHIELD TUBE		2
25	1K306	LOCKNUT MALLEABLE 1/2 X 1-3/16	2	2
26	1K307	PIPE BUSHING ( <b>08MP X 02MP</b> )	2	2
27	5000	ZERK FITTING 1/8NPT	5	5
28	1K305	GREASE HOSE	2	2
29	118-1241	ELBOW, 45 STREET-1/8 NPT BLKI.	2	2

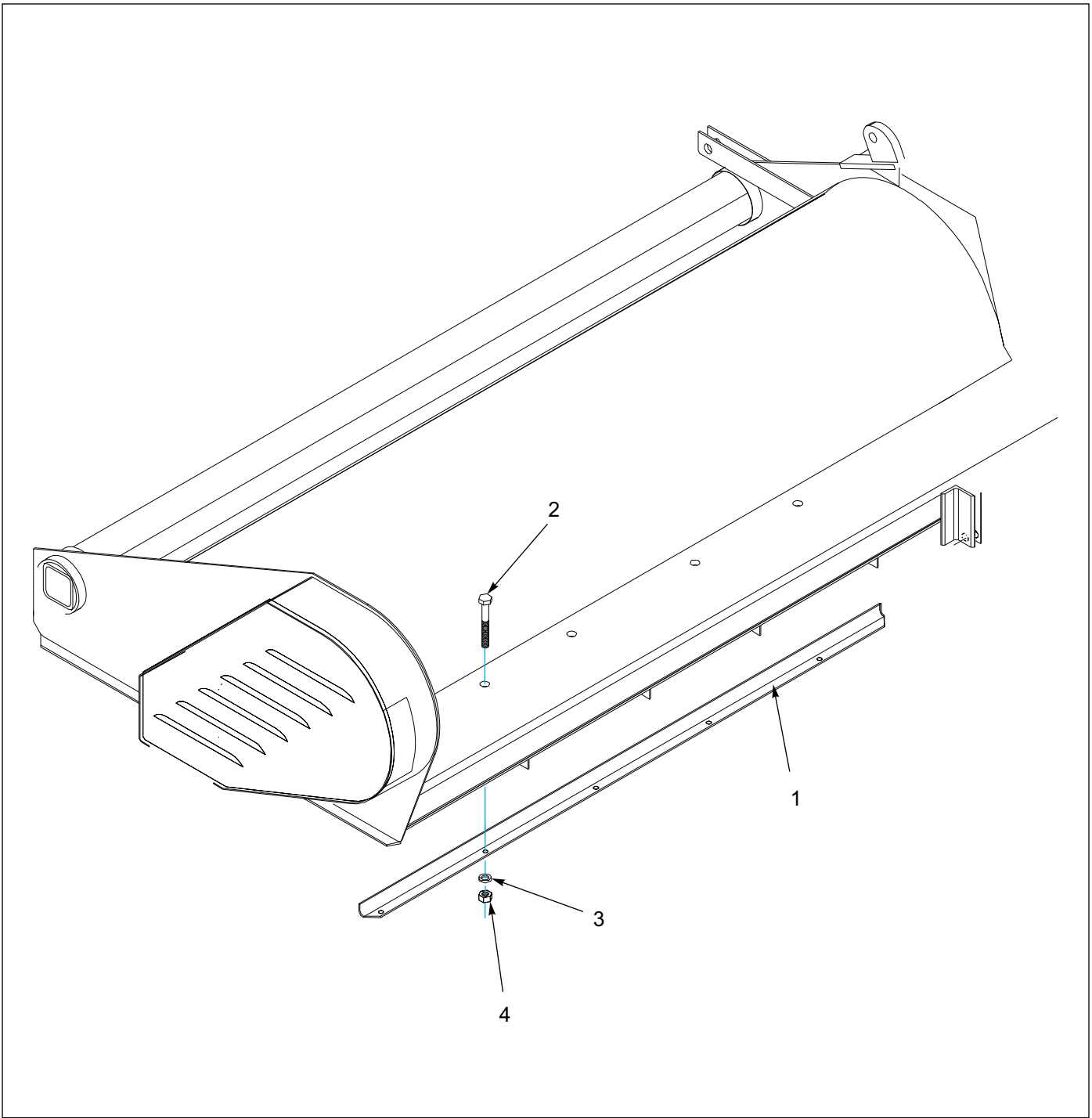

Figure 1-4: Wear Plate - 01/25/2008 and Prior

**Wear Plate - 01/25/2008 and Prior**

ITEM	PART NUMBER	DESCRIPTION	QUANTITY	
			12'	15'
1	4D620	WEAR PLATE		2
1	4D528	WEAR PLATE	2	
2	1-654-010055-01	SCR, HX CP 1/2-13UNC X 1, GR5	12	16
3	1-861-010034-13	WASHER, LKG HLCL SPR, 1/2	12	16
4	1-512-010007-09	NUT, HEX 1/2-13, ZP	12	16



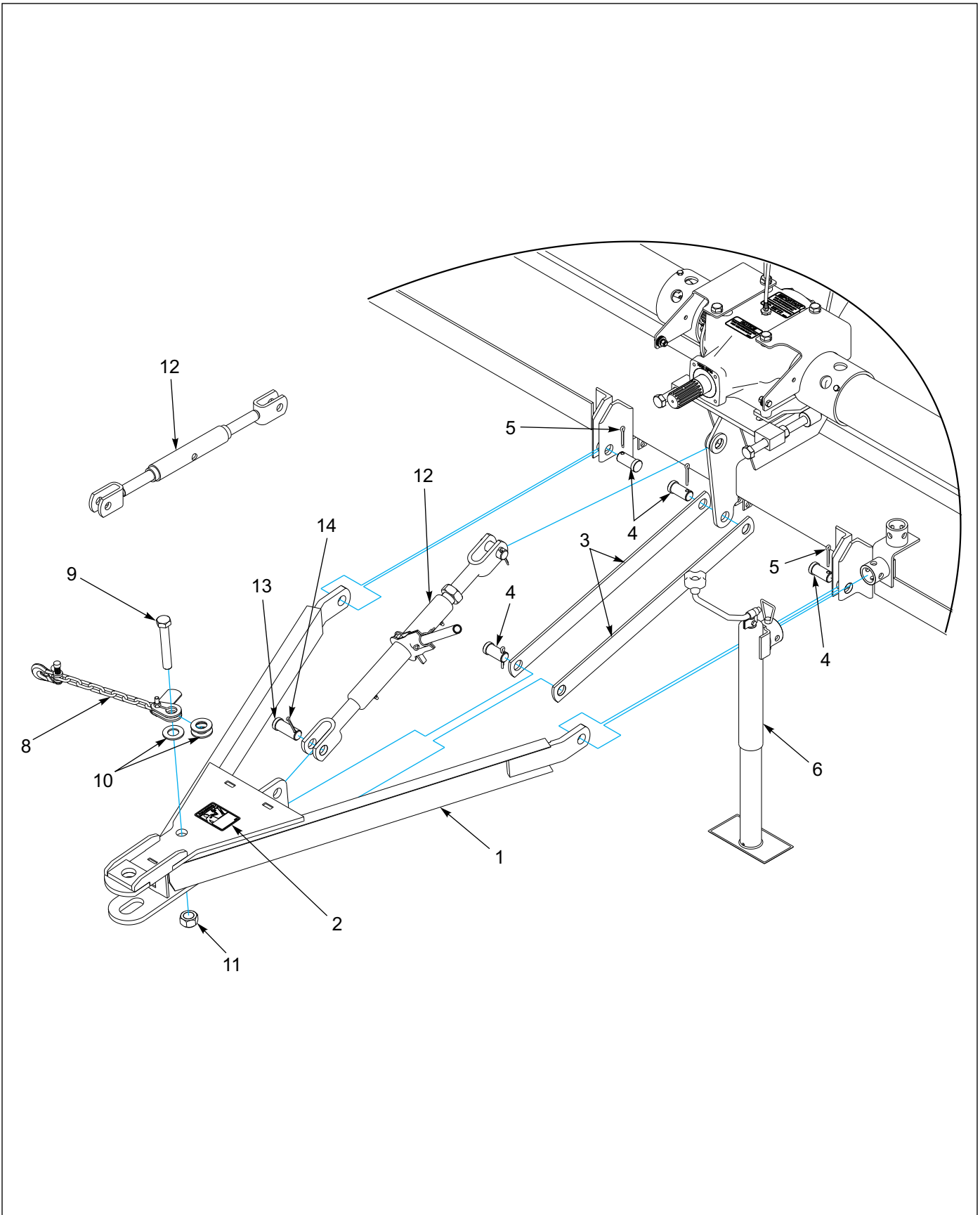

Figure 1-5: Drawbar

## Drawbar

ITEM	PART NUMBER	DESCRIPTION	QTY
1	4D543	FRONT HITCH ASM <b>(INCLUDES ITEM 2)</b>	1
2	3K706	DECAL-WARNING HYDRAULIC LEAKS	1
3	4D557	FRONT DRAWBAR LINK	2
4	4D983	CLEVIS PIN <b>(1.0 X 2.0)</b>	4
5	1/4X1-1/2	COTTER PIN	4
6	3J880	DRAWBAR JACK <b>(INCLUDES ITEM 7)</b>	1
7	6K458	9/16 JACK PIN W/CHAIN & SCREW	1
8	141433	SAFETY CHAIN 11,000LB	1
9	100829	SCREW, HEX CAP, 1-8 X 6-1/2, GR5	1
10	1-861-010032-24	WASHER FL 1IN NARROW, ZP	3
11	1-512-010005-19	NUT 1-8 HEX SLF-LOCKING GRB	1
12	8J206	TURNBUCKLE-REPLACED BY 7J237 <b>(01/25/1990 AND PRIOR)</b>	1
12	7J237	RATCHET JACK <b>(WITH HANDLE) (INCLUDES ITEMS 13 AND 14) (01/26/1990 AND AFTER)</b>	1
13	8D099	CLEVIS PIN <b>(1.0 X 2.5)</b>	2
14	110-4224	PIN, COTTER-3/16 X 2IN LG	2

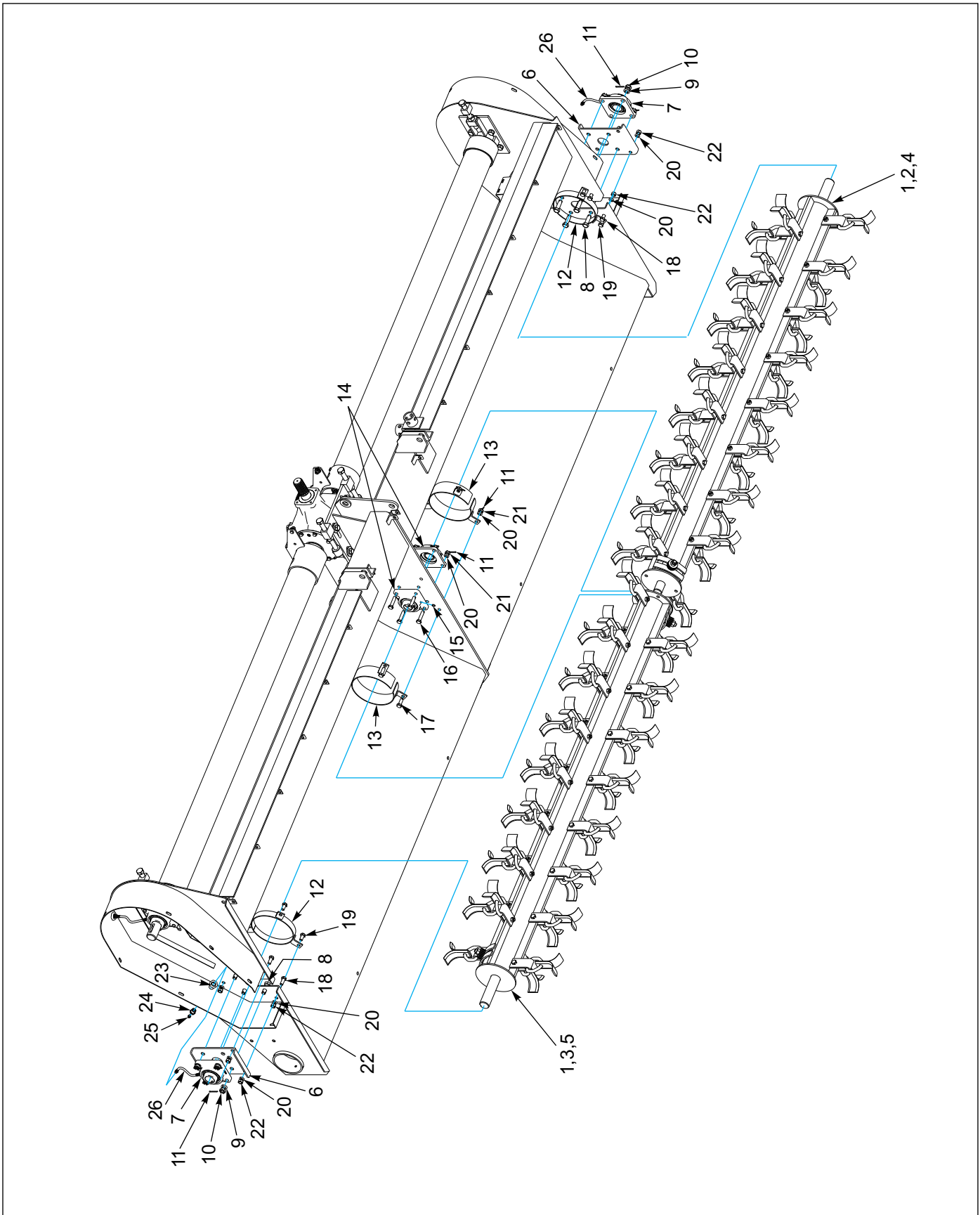

Figure 1-6: Rotor to Frame Assembly

## Rotor to Frame Assembly

ITEM	PART NUMBER	DESCRIPTION	QUANTITY	
			12'	15'
1	9D920	FLAIL ASM 72 IN (SLICE) (SEE PAGE 1-16)	2	
1	9D919	FLAIL ASM 90 IN (SLICE) (SEE PAGE 1-16)		2
2	8J759	FLAIL ASM CUP L.H. 72" (SEE PAGE 1-14)	1	
2	8J757	FLAIL ASM CUP L.H. 90" (SEE PAGE 1-14)		1
3	8J760	FLAIL ASM CUP R.H. 72" (SEE PAGE 1-14)	1	
3	8J758	FLAIL ASM CUP R.H. 90" (SEE PAGE 1-14)		1
4	1K171	FLAIL ASM, SLICE & CUP 72" LH (SEE PAGE 1-12)	1	
4	1K169	FLAIL ASM, SLICE & CUP 90" LH (SEE PAGE 1-12)		1
5	1K172	FLAIL ASM, SLICE & CUP 72" RH (SEE PAGE 1-12)	1	
5	1K170	FLAIL ASM, SLICE & CUP 90" RH (SEE PAGE 1-12)		1
6	4D564	END PLATE STIFFENER	2	2
7	1K309	BEARING ASSEMBLY (1 3/4)	2	2
8	4D538	CAPSCREW DRILLED (5/8-11 X 2)	8	8
9	1-861-010034-15	WASHER, LKG, HLCL SPR, 5/8	8	8
10	4D529	SLOTTED NUT, 5/8-11, ZP	8	8
11	110-0351	COTTER PIN, 1/8 X 1-1/4, ZP	15	15
12	4D579	END BEARING, SHIELD ASSEMBLY	2	2
13	4D581	CENTER BRG, SHIELD ASSEMBLY	2	2
14	4D645	FLANGE BEARING (1-1/2 FLANGE 4 BLT) (INCLUDES ITEM 15)	2	2
15	1-298-010001-1	ZERK FITTING 1/4 SAE (AFTER 11/15/2011)	1	1
15	5000	ZERK FITTING 1/8NPT (PRIOR TO 11/15/2011)	1	1
16	8D350	CAPSCREW - DRILLED (1/2-13 X 2-1/4, GR8)	4	4
17	4C437	CAP SCREW - DRILLED (1/2-13 X 1-1/2, GR2)	3	3
18	1-654-010055-02	SCREW, 1/2-13UNC X 1-1/4 CP, GR5	4	4
19	1-654-010055-01	SCR, HX CP 1/2-13UNC X 1, GR5	6	6
20	1-861-010034-14	WASHER, LKG HLCL SPR, 1/2	17	17
21	2C290	NUT HEX SLOT 1/2-13	7	7
22	1-512-010007-09	NUT, HEX 1/2-13, ZP	10	10
23	1K306	LOCKNUT, MALLEABLE 1/2 X 1-3/16	2	2
24	1K307	PIPE BUSHING (REDUCER, 08MPX02MP)	2	2
25	5000	ZERK FITTING 1/8NPT	2	2
26	1K305	GREASE HOSE	2	2

## ILLUSTRATED PARTS LIST

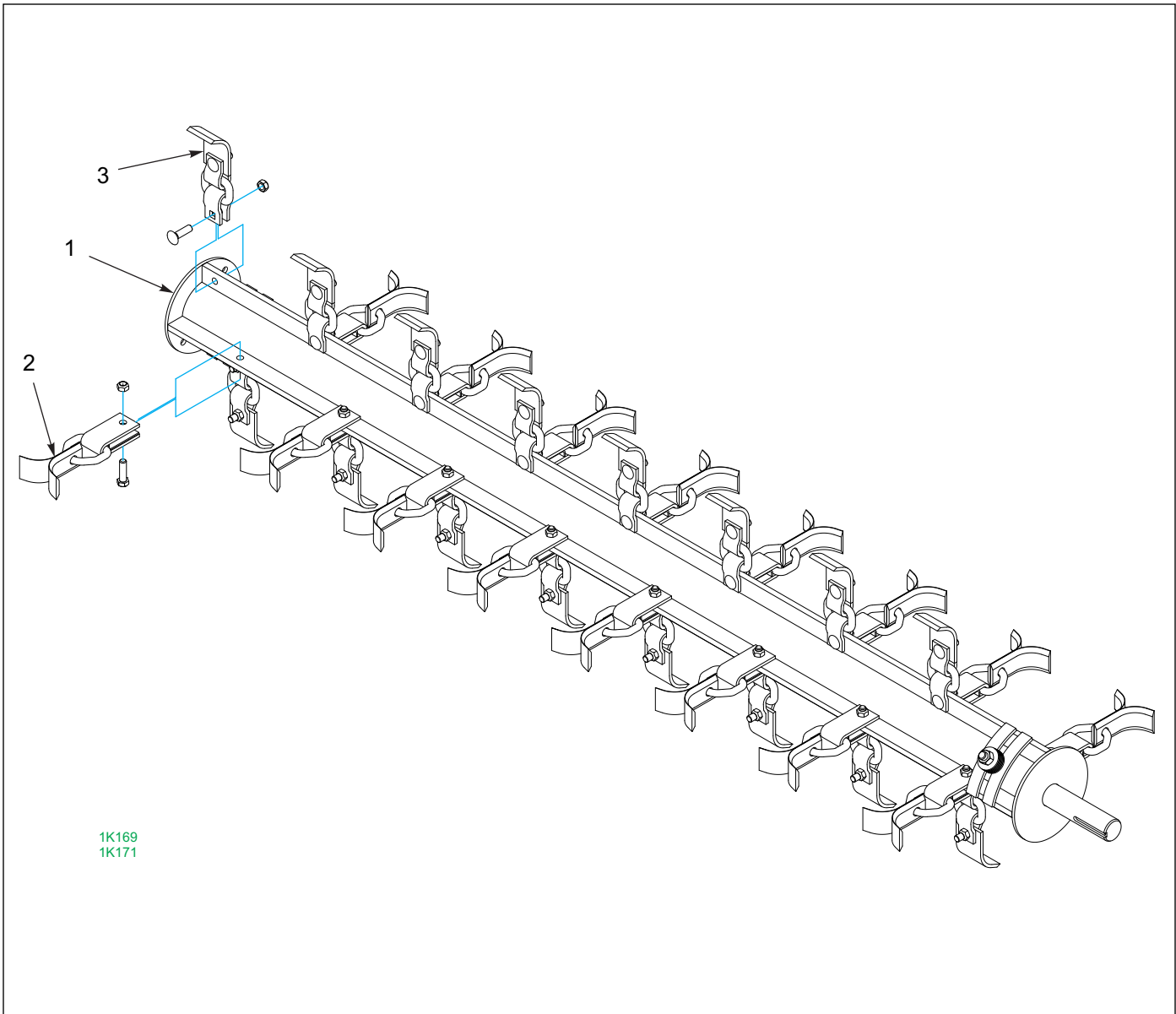

Figure 1-7: Rotor Assemblies, Slice and Cup, Left Hand

### Rotor Assembly, Slice and Cup - Left Hand - 12'

ITEM	PART NUMBER	DESCRIPTION	QTY
	1K171	FLAIL ASM, SLICE & CUP 72" LH	1
1	9D913	FLAIL ROTOR ASSEMBLY (72')	1
2	4D602	KNIFE ASSEMBLY (SEE PAGE 1-18)	12
3	8J807	KNIFE ASSEMBLY (SEE PAGE 1-17)	12

### Rotor Assembly, Slice and Cup - Left Hand - 15'

ITEM	PART NUMBER	DESCRIPTION	QTY
	1K169	FLAIL ASM, SLICE & CUP 90" LH	1
1	9D912	FLAIL ROTOR ASSEMBLY 90 IN	1
2	4D602	KNIFE ASSEMBLY (SEE PAGE 1-18)	16
3	8J807	KNIFE ASSEMBLY (SEE PAGE 1-17)	16



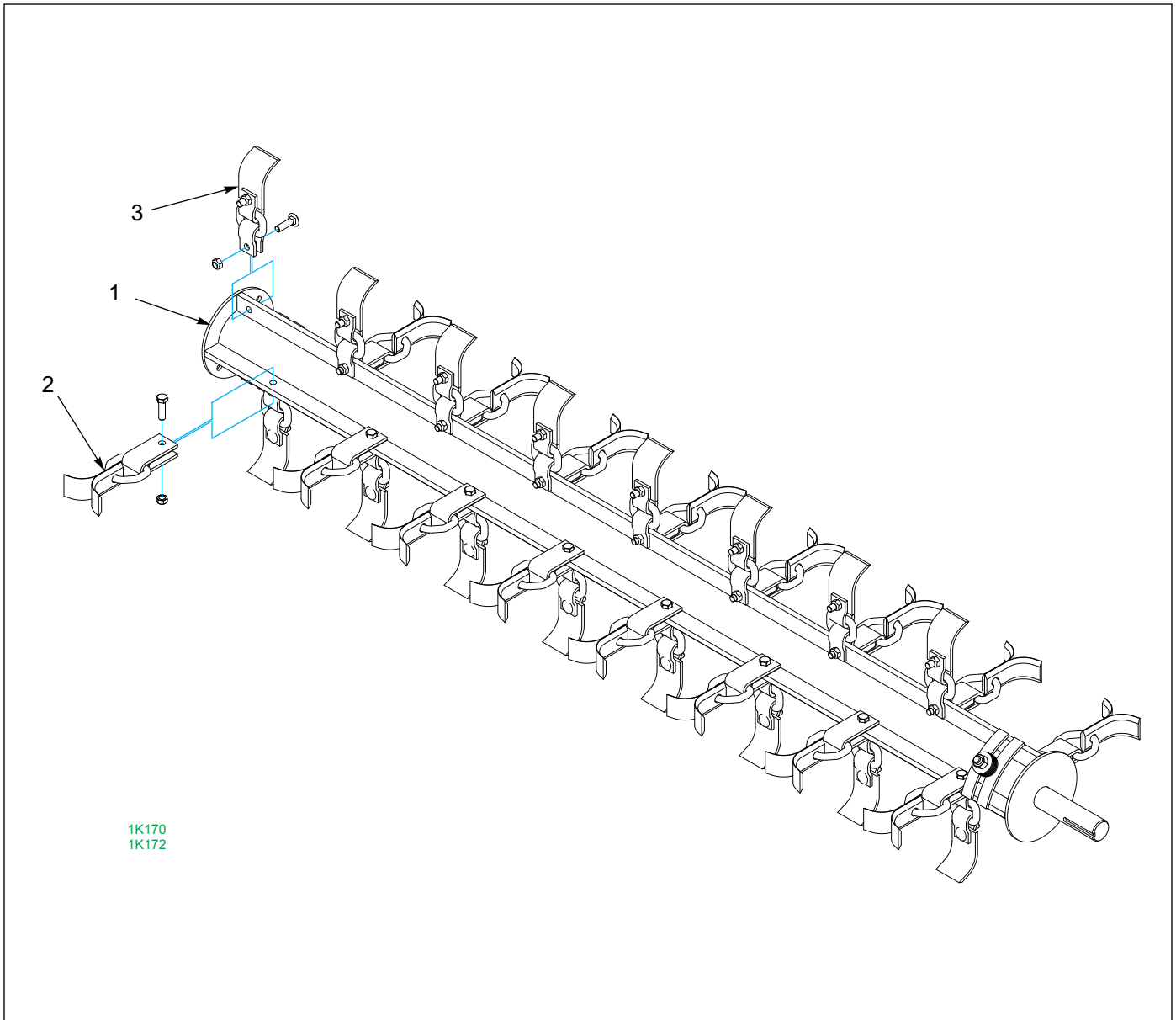

Figure 1-8: Rotor Assemblies, Slice and Cup, Right Hand

**Rotor Assembly, Slice and Cup - Right Hand - 12'**

ITEM	PART NUMBER	DESCRIPTION	QTY
	1K172	FLAIL ASM, SLICE & CUP 72" RH	1
1	9D913	FLAIL ROTOR ASSEM (72')	1
2	4D602	KNIFE ASSEMBLY (SEE PAGE 1-18)	12
3	8J807	KNIFE ASSEMBLY (SEE PAGE 1-17)	12

**Rotor Assembly, Slice and Cup - Right Hand - 15'**

ITEM	PART NUMBER	DESCRIPTION	QTY
	1K170	FLAIL ASM, SLICE & CUP 90" RH	1
1	9D912	FLAIL ROTOR ASSEM 90 IN	1
2	4D602	KNIFE ASSEMBLY (SEE PAGE 1-18)	16
3	8J807	KNIFE ASSEMBLY (SEE PAGE 1-17)	16

# ILLUSTRATED PARTS LIST

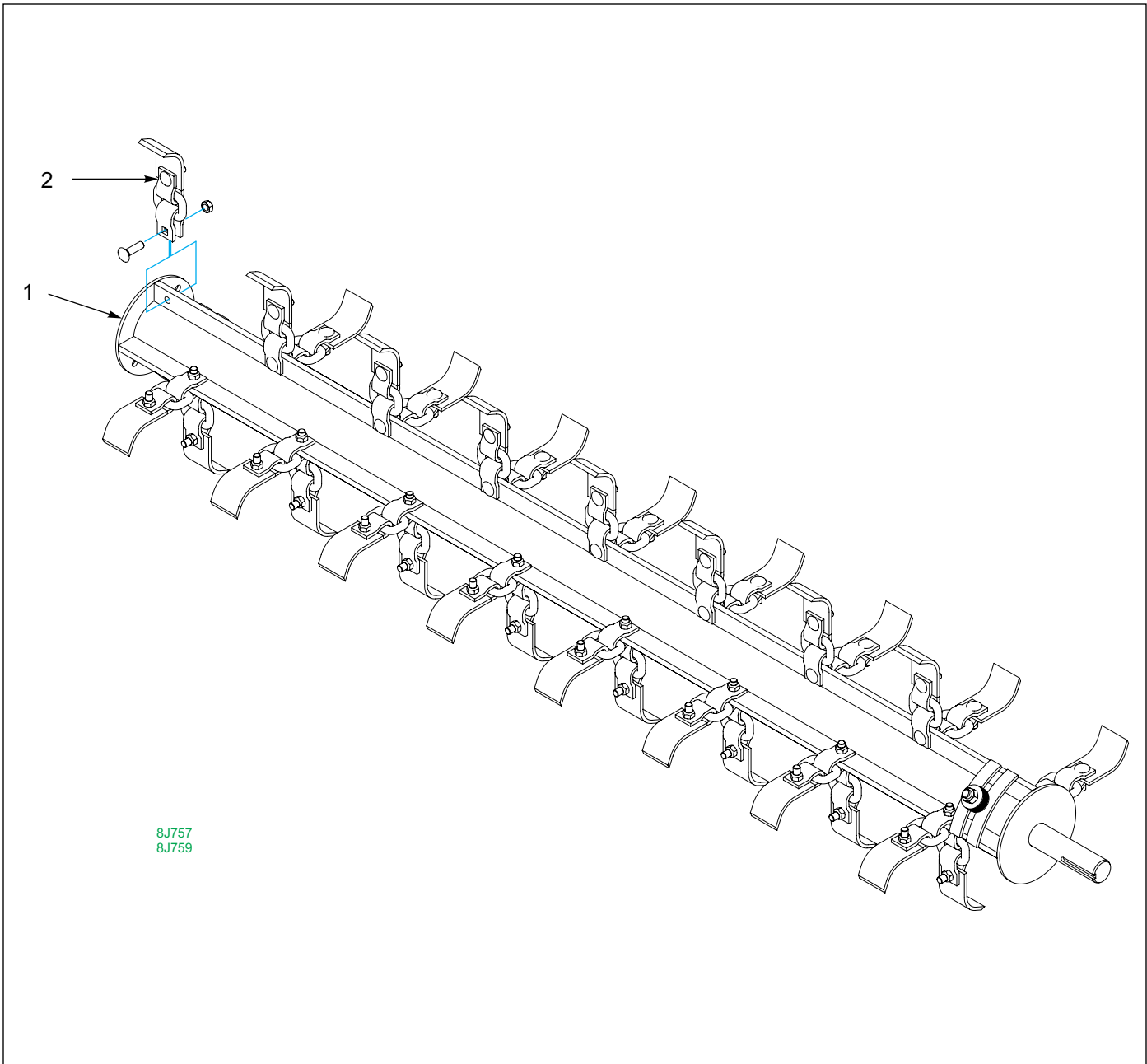

Figure 1-9: Rotor Assemblies, Cup, Left Hand

## Rotor Assembly, Cup - Left Hand - 12'

ITEM	PART NUMBER	DESCRIPTION	QTY
	8J759	FLAIL ASSY CUP L.H. 72"	1
1	9D913	FLAIL ROTOR ASSEMBLY (72")	1
2	8J807	KNIFE ASSEMBLY (SEE PAGE 1-17)	24

## Rotor Assembly, Cup - Left Hand - 15'

ITEM	PART NUMBER	DESCRIPTION	QTY
	8J757	FLAIL ASSY CUP L.H. 90"	1
1	9D912	FLAIL ROTOR ASSEM 90 IN	1
2	8J807	KNIFE ASSEMBLY (SEE PAGE 1-17)	32

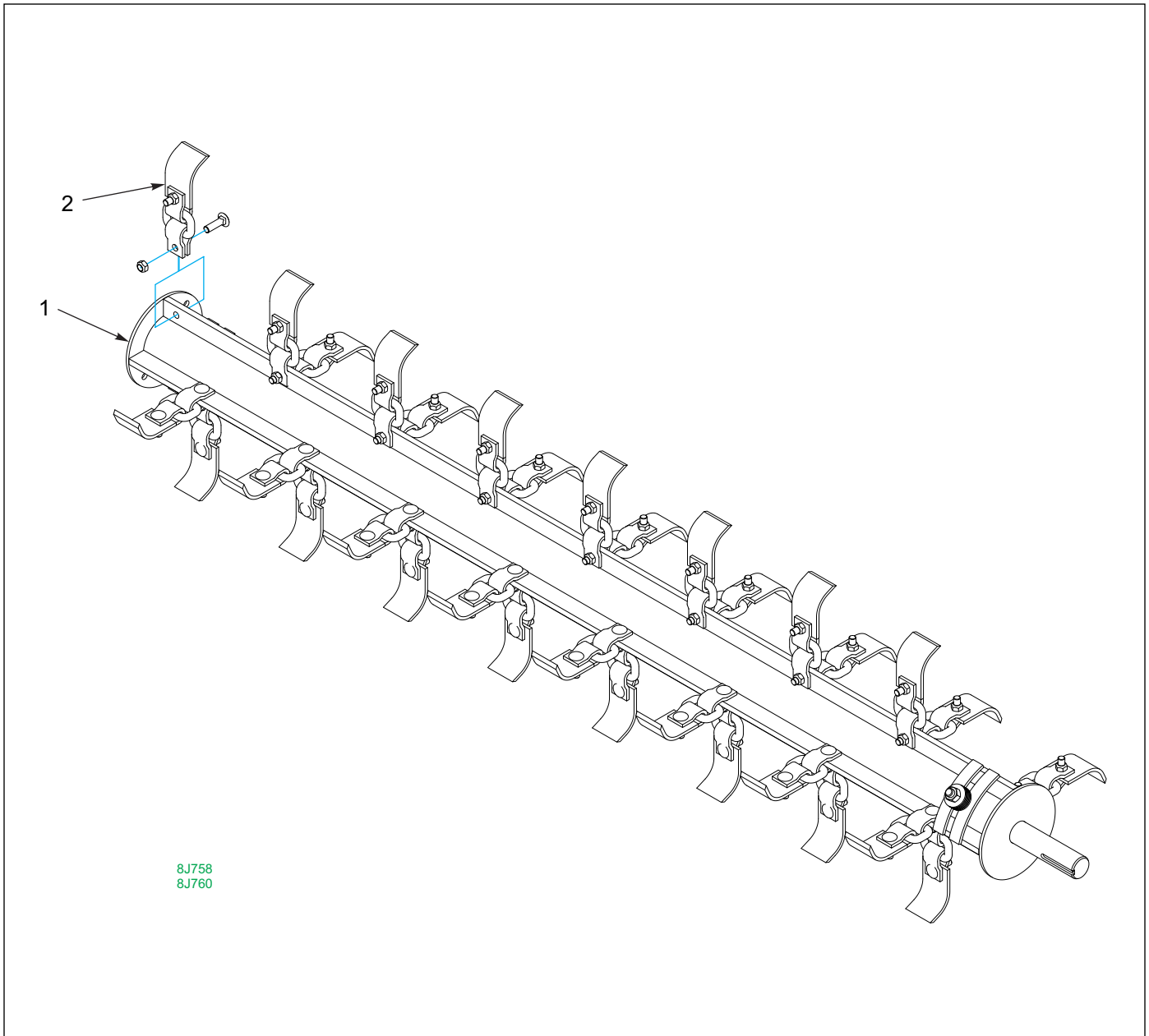

Figure 1-10: Rotor Assemblies, Cup, Right Hand

**Rotor Assembly, Cup - Right Hand - 12'**

ITEM	PART NUMBER	DESCRIPTION	QTY
	8J760	FLAIL ASSY CUP L.H. 72"	1
1	9D913	FLAIL ROTOR ASSEMBLY (72")	1
2	8J807	KNIFE ASSEMBLY (SEE PAGE 1-17)	24

**Rotor Assembly, Cup - Right Hand - 15'**

ITEM	PART NUMBER	DESCRIPTION	QTY
	8J758	FLAIL ASSY CUP R.H. 90"	1
1	9D912	FLAIL ROTOR ASSEM 90 IN	1
2	8J807	KNIFE ASSEMBLY (SEE PAGE 1-17)	32

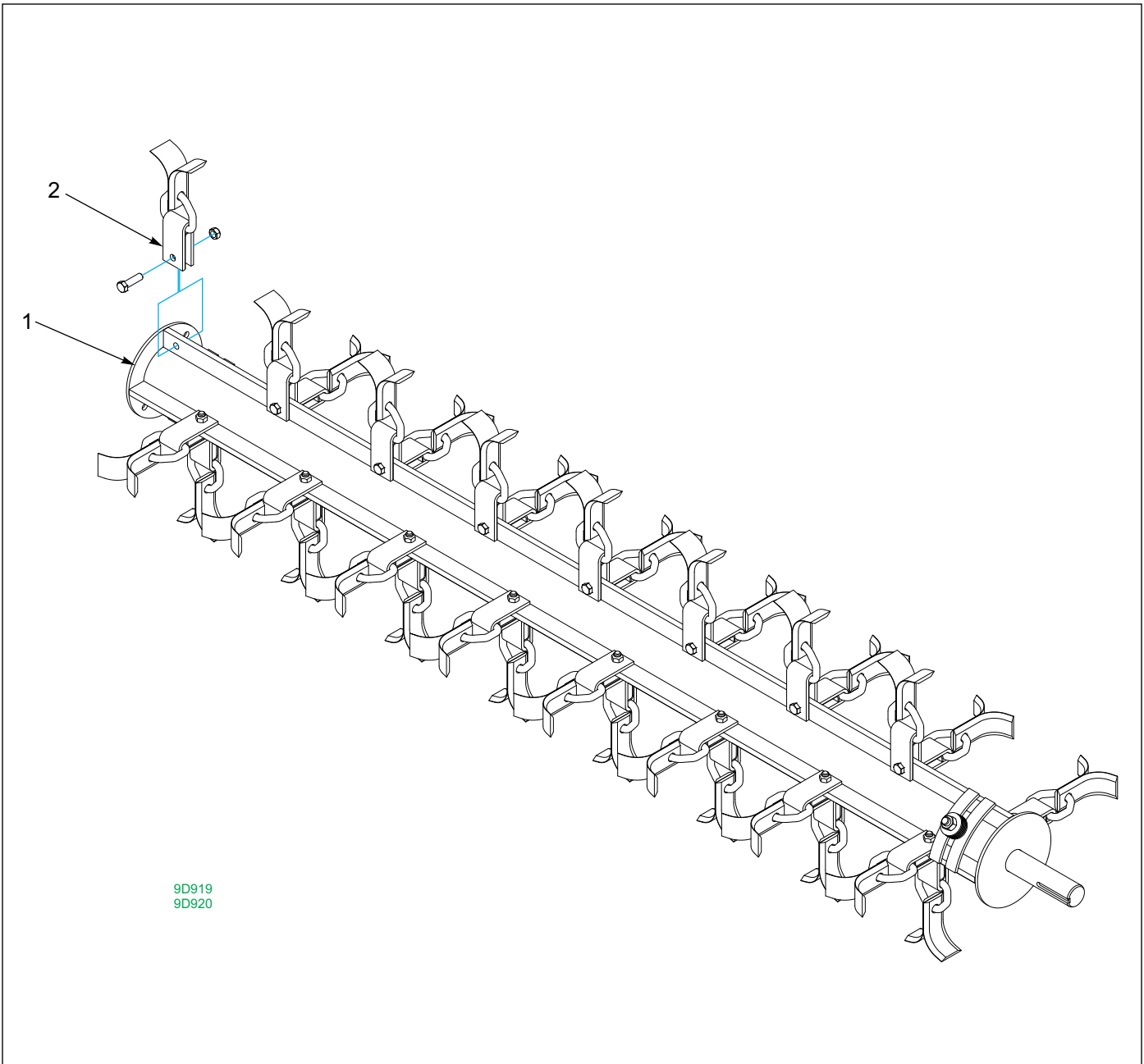

**Figure 1-11: Rotor Assemblies, Slice**

**Rotor Assembly, Slice - 12'**

ITEM	PART NUMBER	DESCRIPTION	QTY
	9D920	FLAIL ASSEMBLY 72 IN	2
1	9D913	FLAIL ROTOR ASSEMBLY (72")	1
2	4D602	KNIFE ASSEMBLY (SEE PAGE 1-18)	24

**Rotor Assembly, Slice - 15'**

ITEM	PART NUMBER	DESCRIPTION	QTY
	9D919	FLAIL ASSEMBLY 90 IN	2
1	9D912	FLAIL ROTOR ASSEM 90 IN	1
2	4D602	KNIFE ASSEMBLY (SEE PAGE 1-18)	32

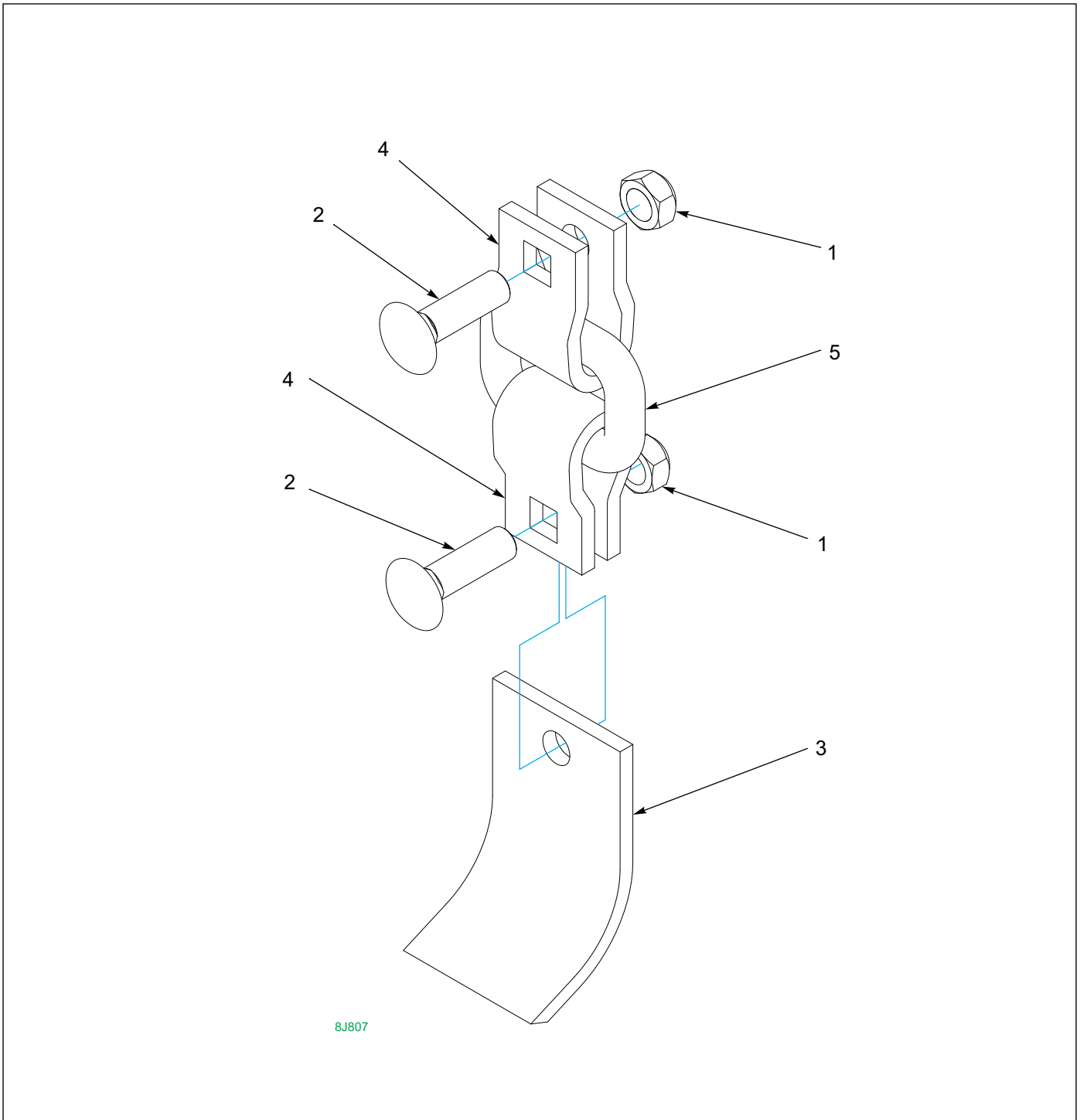

Figure 1-12: Knife Assembly, Cup

### Knife Assembly, Cup

ITEM	PART NUMBER	DESCRIPTION	QTY
	8J807	KNIFE ASSEMBLY	
1	1-512-010005-09	NUT, HEX, SLFLKG, 1/2-13, GRB	2
2	1-654-010070-04	SCREW, RDHD SQNK 1/2-13 X 1-3/4	2
3	8J754	CUP KNIFE	1
4	8J756	U-BAR	2
5	8J755	SQUARE RING	1

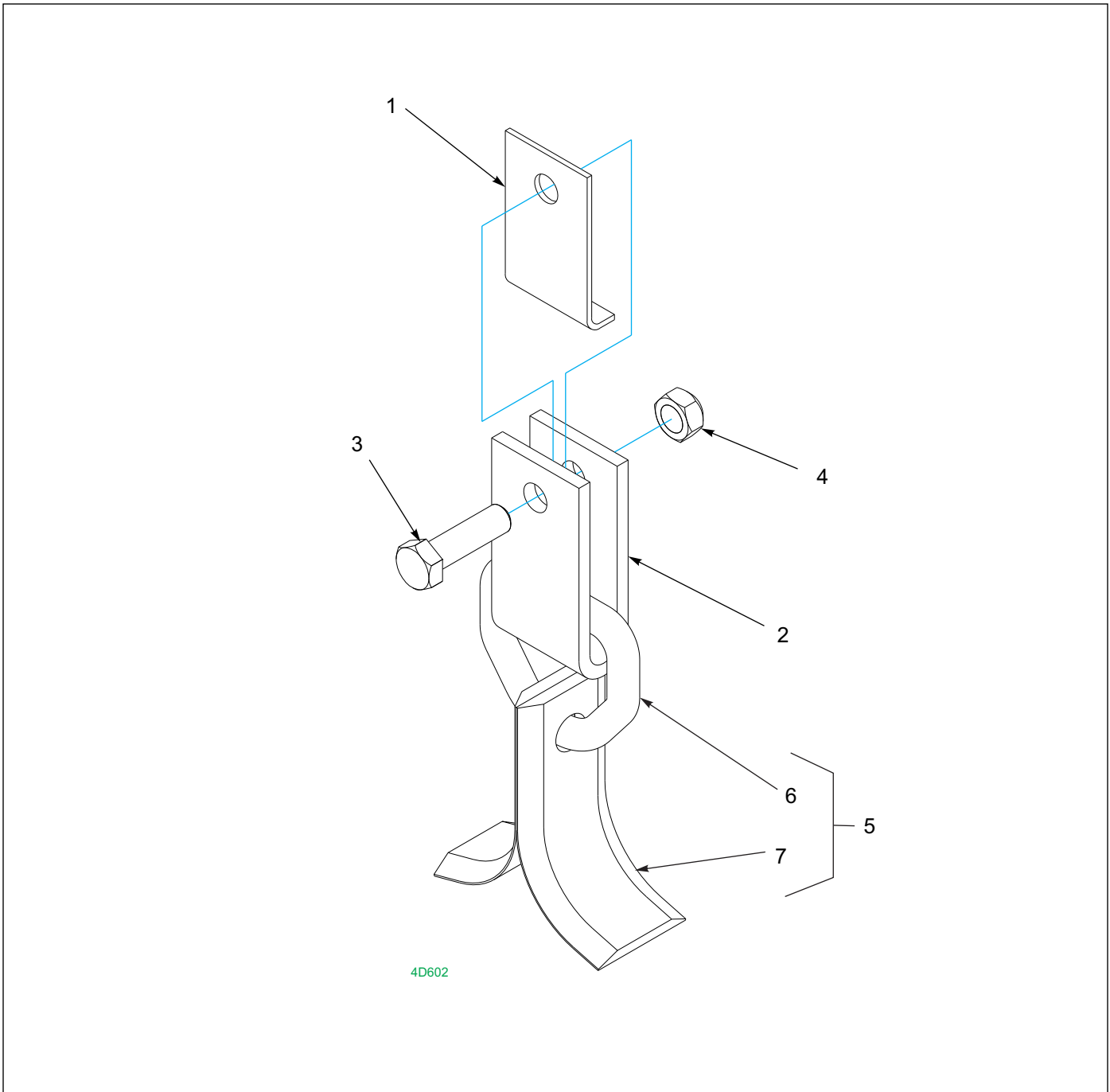

Figure 1-13: Knife Assembly, Slice

### Knife Assembly, Slice

ITEM	PART NUMBER	DESCRIPTION	QTY
	4D602	KNIFE ASSEMBLY	
1	5D333	RETAINER	1
2	5D054	U BRACKET	1
3	1-654-010055-04	SCREW, HEX CAP, 1/2-13UNC X 1-3/4	1
4	1-512-010005-09	NUT, HEX SLFLKG, 1/2-13 GRB	1
5	5D183	D RING KNIFE ASM (INCLUDES ITEMS 6 AND 7)	1
6	5D052	D RING	1
7	5D053	KNIFE, SIDE SLICE	2

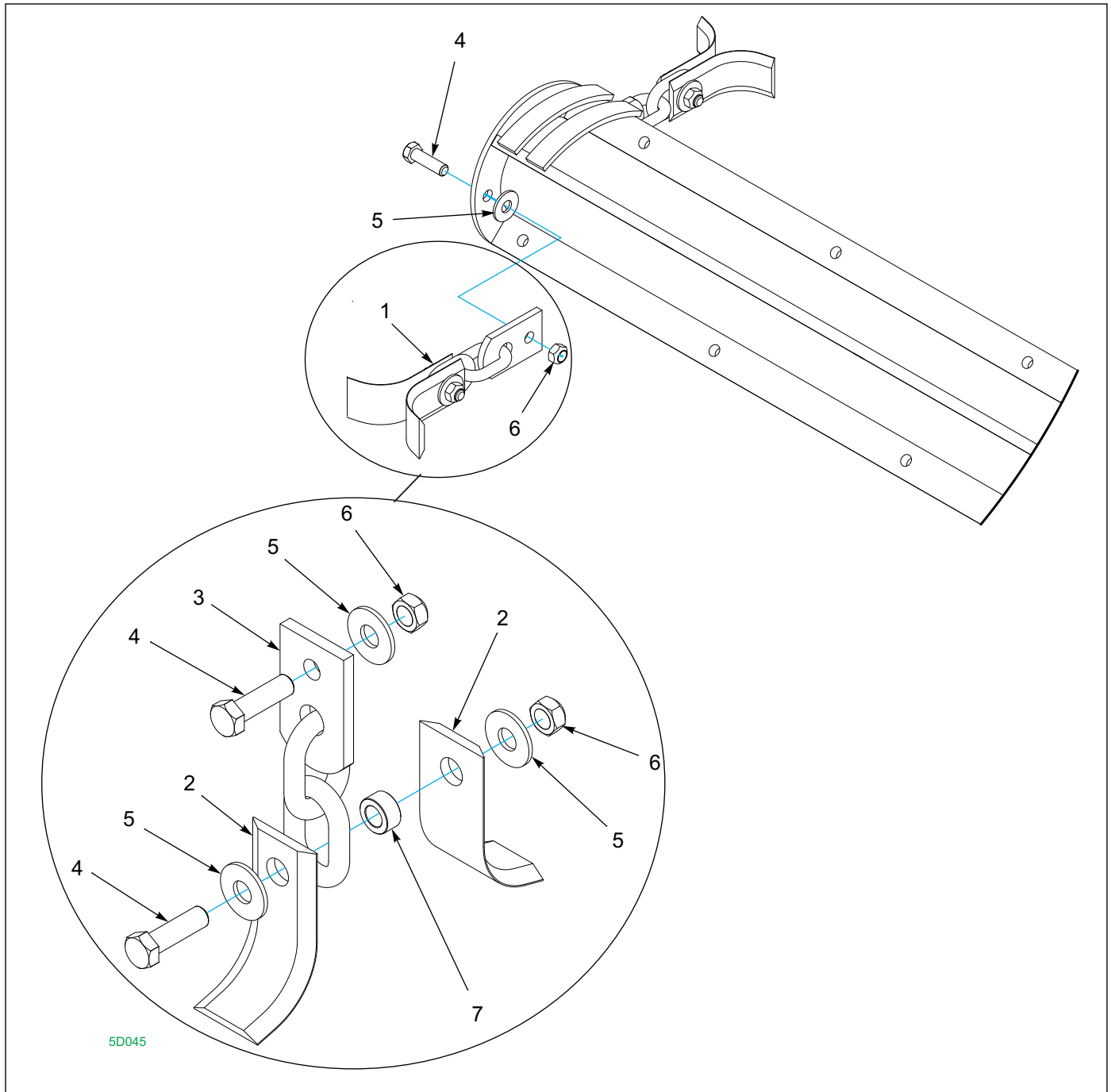

Figure 1-14: Center Cut Kit - Optional

### Center Cut Kit - Optional

ITEM	PART NUMBER	DESCRIPTION	QTY
	5D045	CENTER CUT KIT	
1	5D044	CENTER CUT ASSEMBLY (INCLUDES ITEMS 2-7)	4
2	5D053	KNIFE SIDE SLICE	8
3	5D076	2 LINK CHAIN ASSEMBLY	4
4	1-654-010055-04	SCREW, HEX CAP, 1/2-13UNC X 1-3/4	8
5	1-861-010032-15	WASHER, FLAT 1/2 W ZP/CD	12
6	1-512-010005-09	NUT, HEX, SLFLKG, 1/2-13 GRB	8
7	8J930	SPACER	4

# ILLUSTRATED PARTS LIST

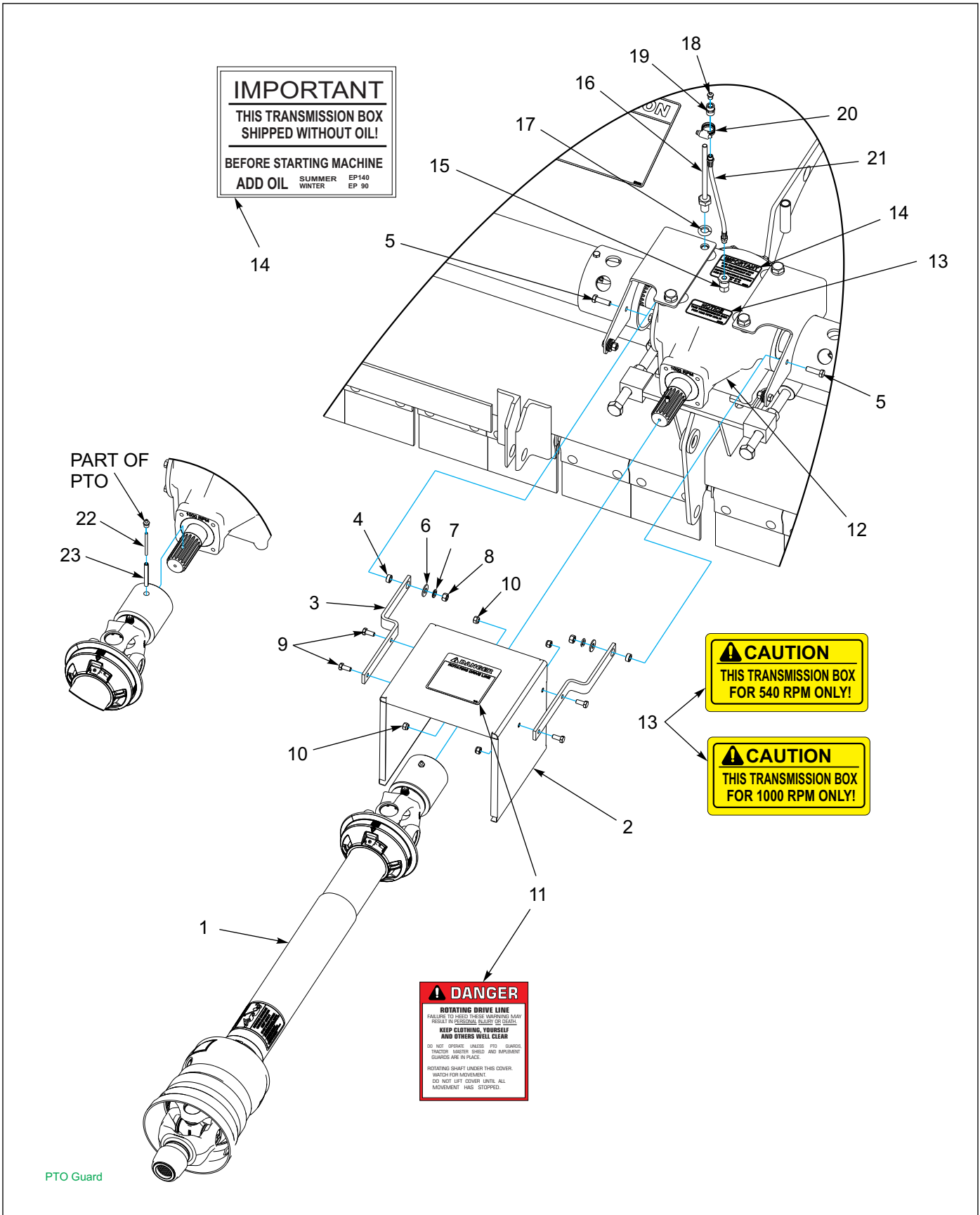

Figure 1-15: PTO Guard



## PTO Guard

ITEM	PART NUMBER	DESCRIPTION	QUANTITY	
			540 RPM	1000 RPM
1	9K726	PTO ASSEM 540 RPM (SEE PAGE 1-30)	1	
1	2P775	PTO ASM-1000 RPM REPLD 9K727 (SEE PAGE 1-28)		1
2	7D020	SHIELD	1	1
3	7D019	ARM	2	2
4	1D991	BUSHING	2	2
5	1-654-010051-06	SCREW, HEX CAP 3/8-16UNC X 1-1/4	2	2
6	1-861-010032-11	WASHER, FLAT 3/8 W ZP/CD	2	2
7	1-861-010034-11	WASHER, LKG HLCL SPR, 3/8	2	2
8	1-512-010007-07	NUT, HEX 3/8-16, ZP	2	2
9	1-654-010049-03	SCREW, HX CP 5/16-18 X 3/4, GR5	4	4
10	104032	NUT, HX SLF-LKG W/MYL 5/16-18	4	4
11	2J099	"DANGER" DECAL	1	1
12	3K098	540 RPM GEARBOX ASSEMBLY (SEE PAGE 1-22)	1	
12	3K099	1000 RPM BOX ASSEMBLY (SEE PAGE 1-22)		1
13	5D019	DECAL - CAUTION (540 RPM)	1	
13	5D020	"CAUTION" DECAL (1000 RPM)		1
14	9C594	LUBE STICKER	1	1
15	3D978	PIPE REDUCER BUSHING (08MP X 02MP)	1	1
16	3K083	ROD WELDMENT	1	1
17	1-861-010034-15	WASHER, LKG, HLCL SPR, 5/8	1	1
18	3K371	PRESSURE VENT	1	1
19	3K089	PIPE COUPLING (1/8)	1	1
20	3K090	HOSE CLAMP (4-1/2 IDEAL #5264)	1	1
21	1K305	GREASE HOSE	1	1
22	2C733	ROLL PIN 3/16 X 2-1/2	1	1
23	9J206	5/16 X 2-1/2 ROLL PIN	1	1



**Gearbox Assembly, 540 RPM**

ITEM	PART NUMBER	DESCRIPTION	QTY
	3K098	540 RPM GEARBOX ASSEMBLY	
1	3K343	GEARBOX HOUSING	1
2	1-076-010002	CUP (3.265 O.D. BEARING CUP)	3
3	1D759	BEARING CONE	3
4	3K345	GEAR - 16 TOOTH	1
5	3K346	SPACER	1
6	3K382	SNAP RING	1
7	3K365	DRIVEN SHAFT (540 RPM)	1
8	3K366	WASHER (1 3/4 I.D. X 3/16)	3
9		COVER	1
10		PIPE PLUG, 1/4 N.P.T.	1
11	3K383	SEAL	2
12	1-654-010051-05	SCREW, HEX CAP 3/8-16UNC X 1, GR5	8
13	1-861-010034-11	WASHER, LKG HLCL SPR, 3/8	8
14	3K368	COVER FOR FLAIL GEAR BOX	1
15	3K381	SNAP RING	2
16	3K369	SHIM .007 (1 3/4 I.D.)	REF
17	3K370	GEAR - 29 TOOTH	1
18	3K384	BEARING CONE	1
19	3K385	BEARING CUP	1
20	3K372	KEY, HARDENED 3/8" SQ X 1-7/16	1
21	3K373	DRIVE SHAFT	1
22	3K386	SEAL	1
23		BOLT (3/8 X 3/4)	8
24	3K375	SHIM .007	REF

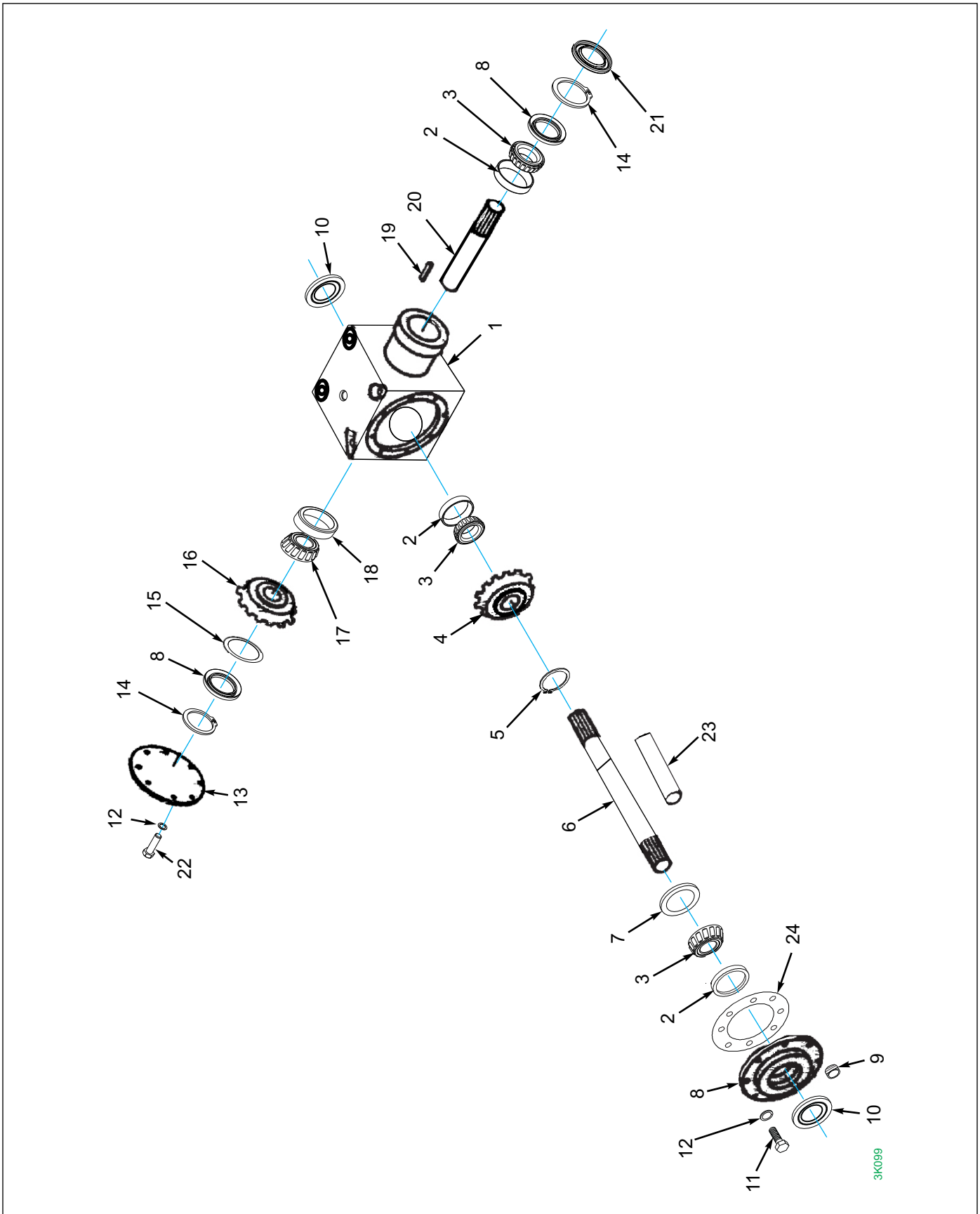

Figure 1-17: Gearbox Assembly, 1000 RPM

## Gearbox Assembly, 1000 RPM

ITEM	PART NUMBER	DESCRIPTION	QTY
	3K099	1000 RPM BOX ASSEMBLY	
1	3K343	GEARBOX HOUSING	1
2	1-076-010002	CUP (3.265 O.D. BEARING CUP)	3
3	1D759	BEARING CONE	3
4	3K344	GEAR - 22 TOOTH	2
5	3K381	SNAP RING	3
6	3K364	DRIVEN SHAFT (1000 RPM)	1
7	3K366	WASHER (1 3/4 I.D. X 3/16)	3
8		COVER	1
9		PIPE PLUG, 1/4 N.P.T.	1
10	3K383	SEAL	2
11	1-654-010051-05	SCREW, HEX CAP 3/8-16UNC X 1, GR5	8
12	1-861-010034-11	WASHER, LKG HLCL SPR, 3/8	8
13	3K368	COVER FOR FLAIL GEAR BOX	1
14	3K381	SNAP RING	2
15	3K369	SHIM .007 (1 3/4 I.D.)	REF
16	3K344	GEAR - 22 TOOTH	2
17	3K384	BEARING CONE	1
18	3K385	BEARING CUP	1
19	3K372	KEY, HARDENED 3/8" SQ X 1-7/16	1
20	3K373	DRIVE SHAFT	1
21	3K386	SEAL	1
22	1-654-010051-03	SCREW, HEX CAP, 3/8-16UNC X 3/4, G5	8
23	3K374	SPACER TUBE (15 FT ONLY)	1
24	3K375	SHIM .007	REF

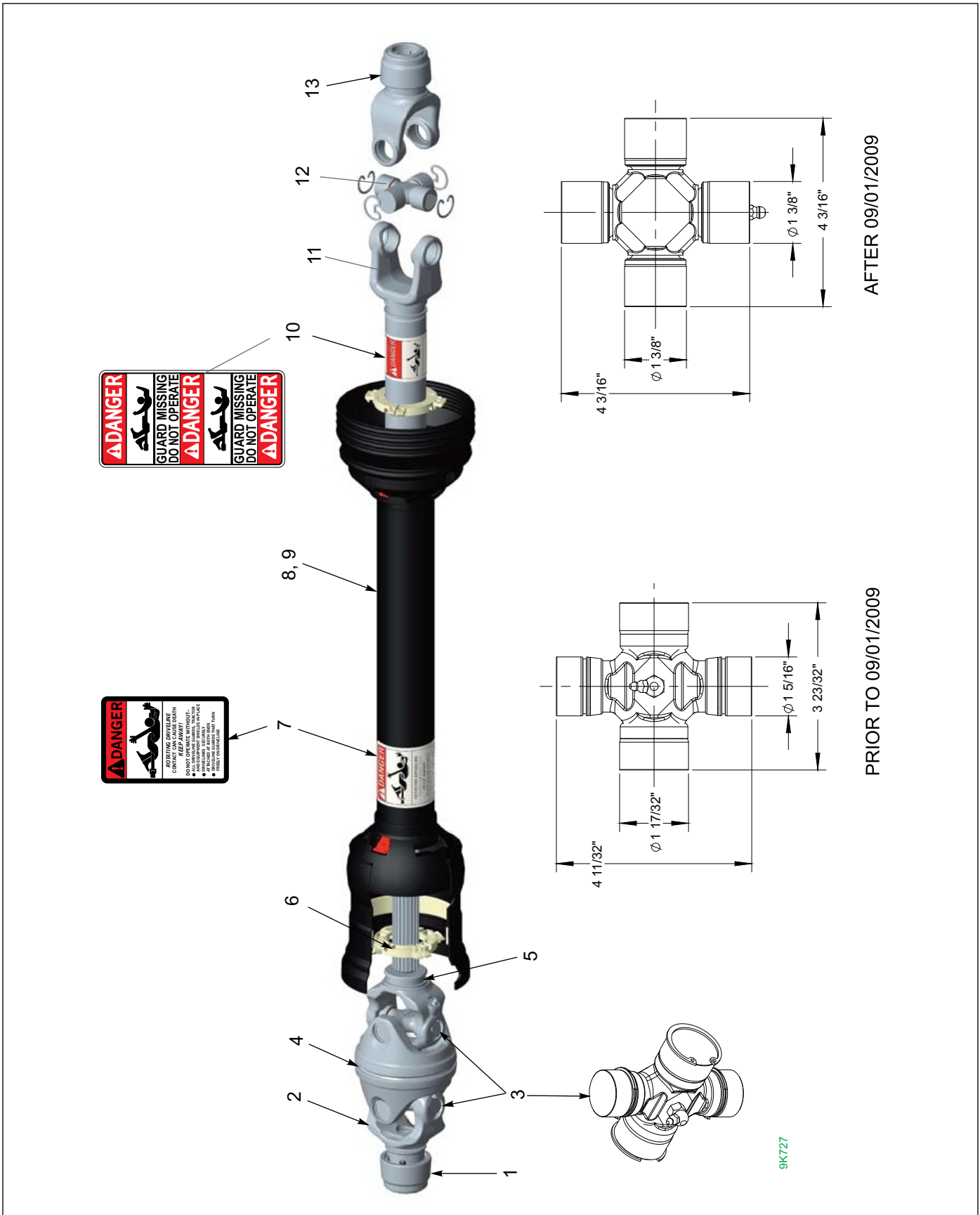

Figure 1-18: PTO Assembly, 1000 RPM - Shredder Serial Number 202950 and Lower

## PTO Assembly, 1000 RPM - Shredder Serial Number 202950 and Lower

ITEM	PART NUMBER	DESCRIPTION	QTY
	9K727	PTO ASM - REPLACED BY 2P775	
1	8J297	SLIDE LOCK YOKE REPAIR KIT	1
2		SAFETY SLIDE LOCK YOKE ASSEMBLY	1
3	6K901	CAT5 CROSS & BEARING KIT	2
4		CENTER HOUSING	1
5		YOKE & SHAFT (1.69-20)	1
6	8K987	BRG KIT FOR ROTATING GUARD <b>(INCLUDES NYLON BEARING AND CLIPS)</b>	2
7		"DANGER" ROTATING DRIVELINE DECAL	1
8		OUTER GUARD	1
9		INNER GUARD	1
10		"DANGER" GUARD MISSING DECAL	1
11	6K908	YOKE, TUBE & SLIP SLEEVE <b>(INCLUDES ITEM 10)</b>	1
12	1D134	CROSS & BEARING KIT 55R	1
13	9J205	OVERRUNNING CLUTCH	1
14	9K729	REPAIR KIT O/R CLUTCH <b>(THE REPAIR KIT FOR MACHINES PRIOR TO 01/01/1997 IS OBSOLETE, ORDER ITEM 13)</b>	REF
15	6K907	INNER AND OUTER GUARD SET <b>(INCLUDES ITEMS 6-9)</b>	REF
16	9K730	JOINT & TUBE HALF <b>(INCLUDES ITEMS 11-14)</b>	REF

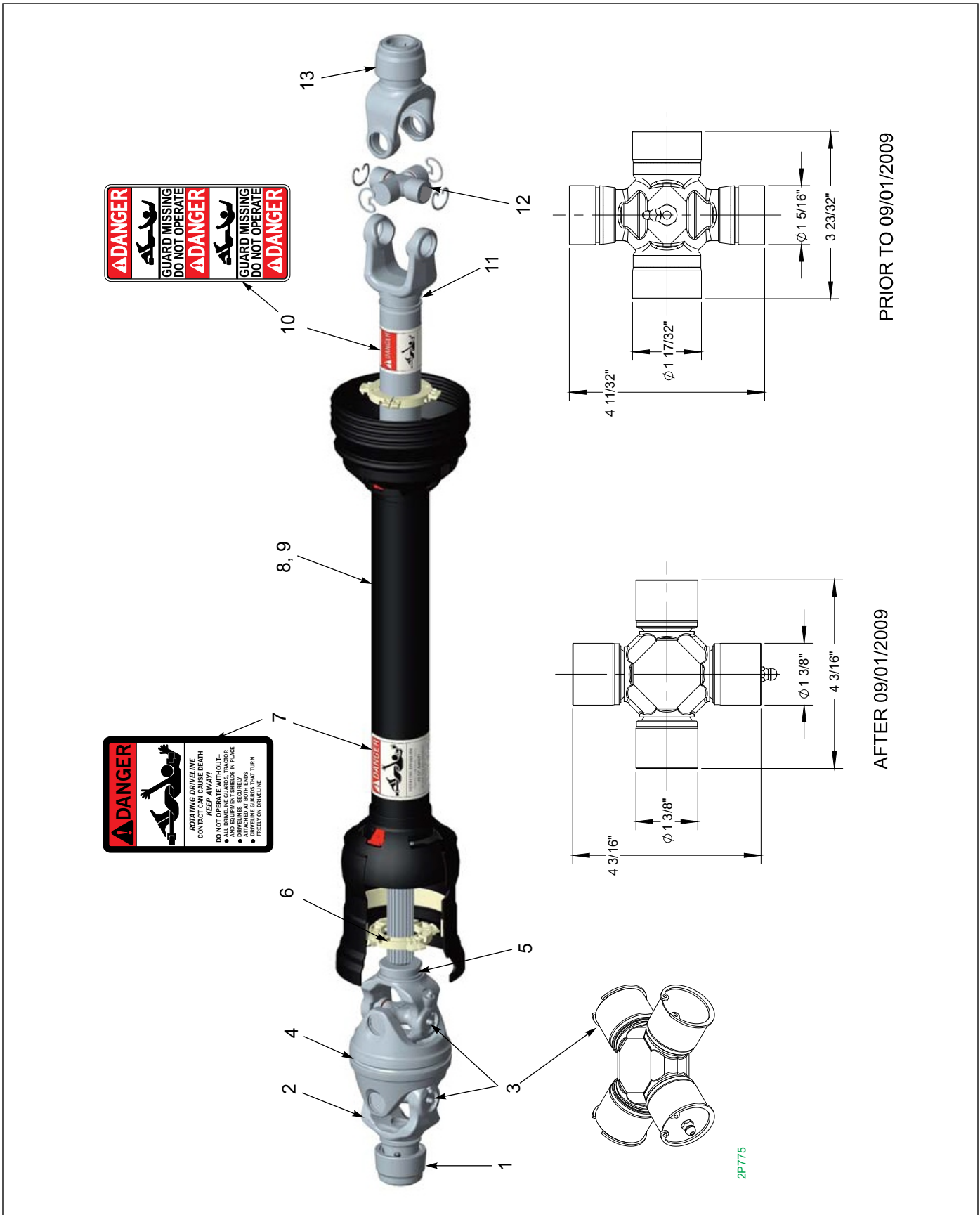

Figure 1-19: PTO Assembly, 1000 RPM - Shredder Serial Number 202951 and Higher



## PTO Assembly, 1000 RPM - Shredder Serial Number 202951 and Higher

ITEM	PART NUMBER	DESCRIPTION	QTY
	2P775	PTO ASM-1000 RPM REPLD 9K727	
1	8J297	SLIDE LOCK YOKE REPAIR KIT	1
2	2P778	WWCV AUTO-LOK YOKE ASM	1
3	2P779	CROSS AND BEARING KIT	2
4	2P780	WWCV CENTER HSG	1
5	2P781	YOKE & SHAFT (1.69-20)	1
6	8K987	BRG KIT FOR ROTATING GUARD <b>(INCLUDES NYLON BEARING AND CLIPS)</b>	2
7		"DANGER" ROTATING DRIVELINE DECAL	1
8		OUTER GUARD	1
9		INNER GUARD	1
10		"DANGER" GUARD MISSING DECAL	1
11	6K908	YOKE, TUBE & SLIP SLEEVE <b>(INCLUDES ITEM 10)</b>	1
12	1D134	CROSS & BEARING KIT 55R	1
13	9J205	OVERRUNNING CLUTCH	1
14	9K729	REPAIR KIT O/R CLUTCH <b>(THE REPAIR KIT FOR MACHINES PRIOR TO 01/01/1997 IS OBSOLETE, ORDER ITEM 13)</b>	REF
15	6K907	INNER AND OUTER GUARD SET <b>(INCLUDES ITEMS 6-9)</b>	REF
16	2P776	JOINT & SHAFT W/GUARD <b>(INCLUDES ITEMS 1-8)</b>	REF
17	2P777	JOINT & SHAFT ASM <b>(INCLUDES ITEMS 1-5)</b>	REF
18	9K730	JOINT & TUBE HALF <b>(INCLUDES ITEMS 10-13)</b>	REF

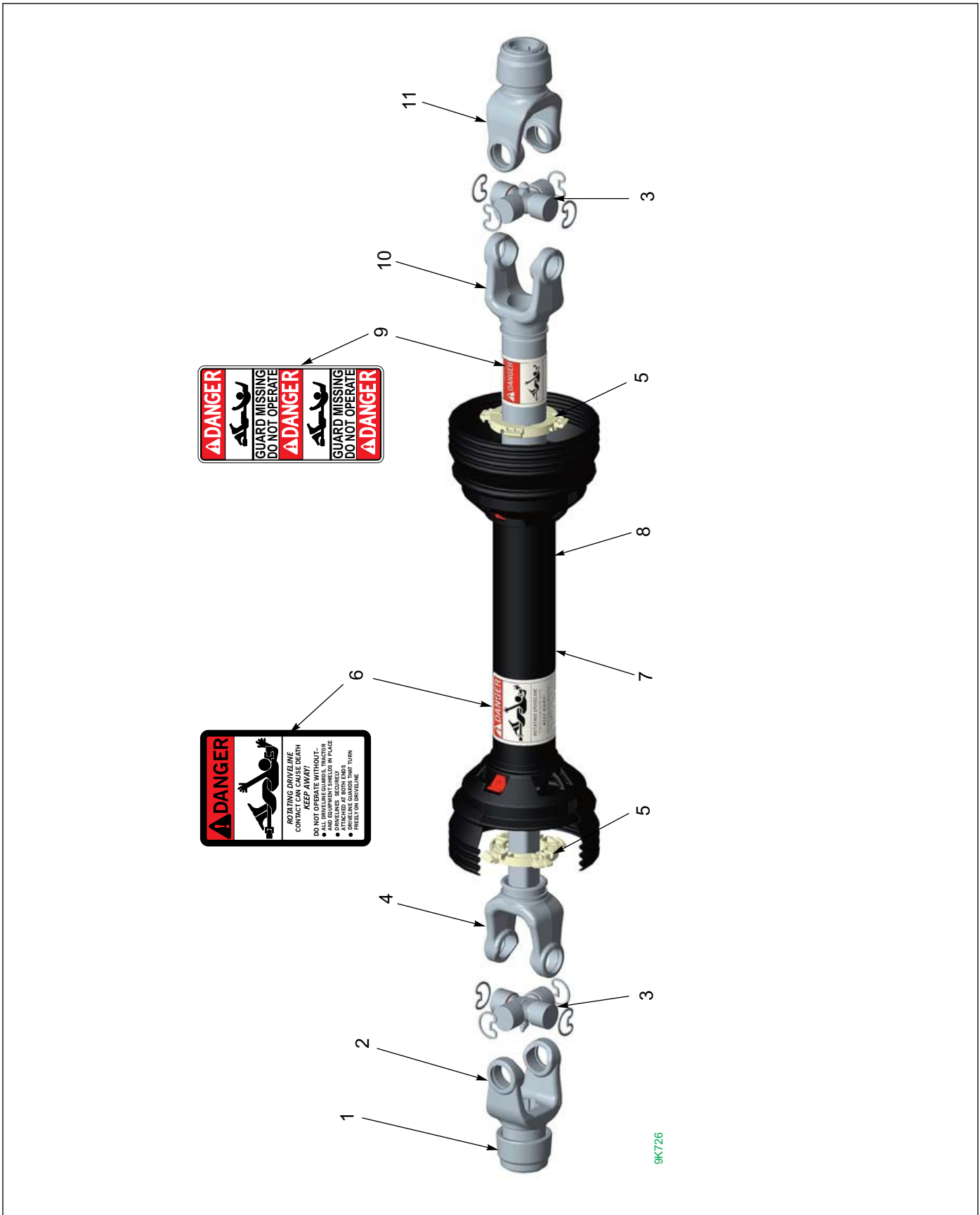

Figure 1-20: PTO Assembly, 540 RPM

## PTO Assembly, 540 RPM

ITEM	PART NUMBER	DESCRIPTION	QTY
	9K726	PTO ASSEM 540 RPM	
1	8J297	SLIDE LOCK YOKE REPAIR KIT	1
2	8J294	SLIDE LOCK YOKE ASM - 540	1
3	1D134	CROSS & BEARING KIT 55R	2
4		YOKE AND SHAFT	1
5	8J295	NYLON BEARING & RETAINER (GUARD REPAIR KIT) (GUARD BELL 6.80)	2
5	208499	GUARD REPAIR KIT (GUARD BELL 7.28 DIA)	2
6		"DANGER" ROTATING DRIVELINE DECAL	1
7	8J291	OUTER GUARD	1
8	8J292	INNER GUARD	1
9		"DANGER" GUARD MISSING DECAL	1
10		YOKE, TUBE AND SLIP SLEEVE	1
11	9J205	OVERRUNNING CLUTCH	1
12	9K729	REPAIR KIT O/R CLUTCH (THE REPAIR KIT FOR MACHINES PRIOR TO 01/01/1997 IS OBSOLETE, ORDER ITEM 11)	REF
13	8J287	SHAFT & JNT, ASM - 540 RPM (WITH GUARD) (INCLUDES ITEMS 1-7)	REF
14	9K728	JOINT & TUBE HALF W/GUARD (INCLUDES ITEMS 3, 5, AND 8-12)	REF

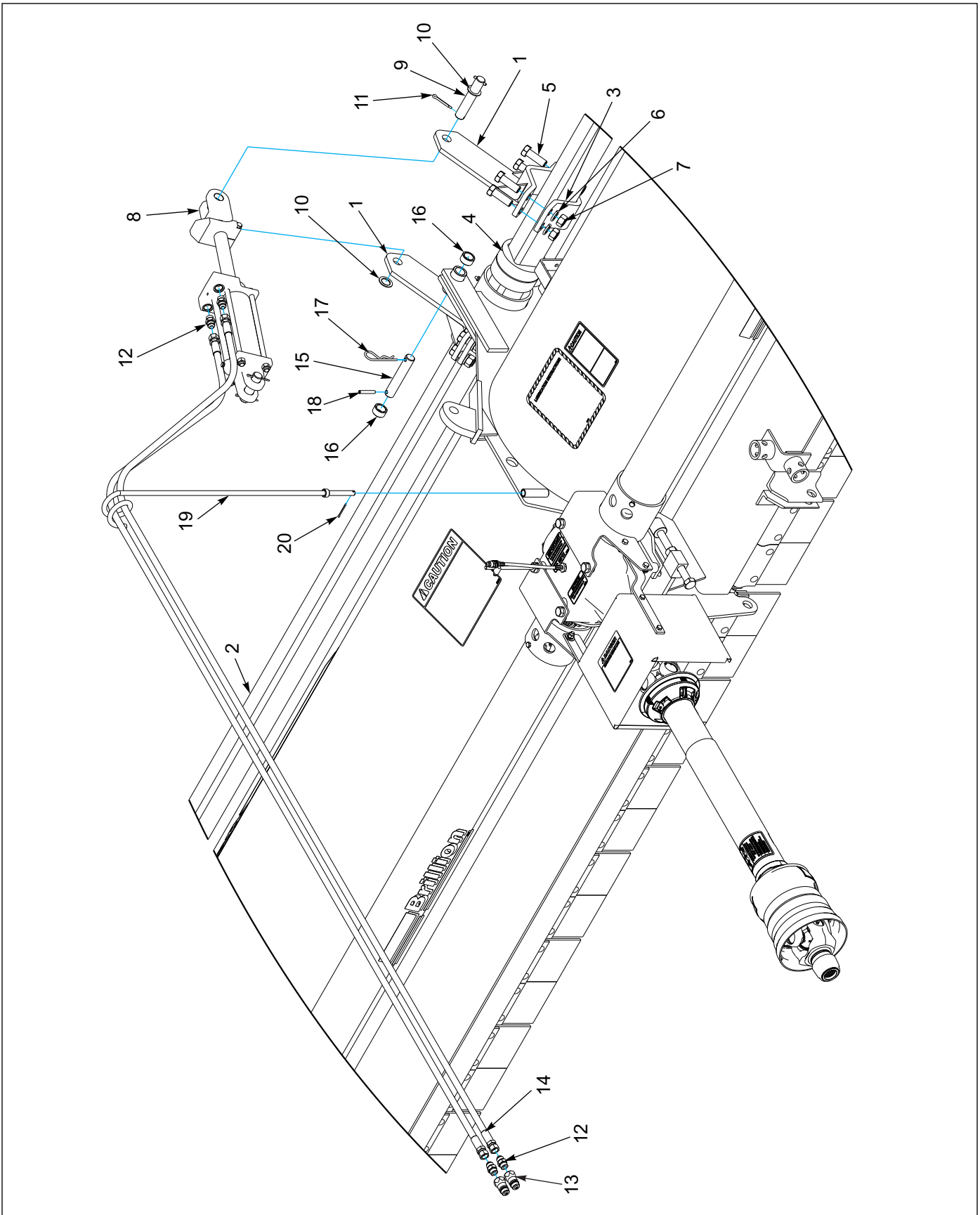

Figure 1-21: Hydraulic Components

## Hydraulic Components

ITEM	PART NUMBER	DESCRIPTION	QTY
1	8J191	CYLINDER ARM	2
2	8J255	PIVOT TUBE	1
3	8J268	CLAMP PLATE	2
4	8J187	BEARING	1
5	4D957	SCREW, HXCP, 3/4-10UNC X 2-1/4, GR5	8
6	1-861-010034-17	WASHER, LKG, HLCL SPR, 3/4	8
7	1-512-010007-12	NUT, HEX 3/4-10 GR2, ZP	8
8	3J603	HYDRAULIC CYLINDER <b>(SEE PAGE 1-45)</b>	1
9	5J572	PIN ASSEMBLY	1
10	7C076	MACHINERY BUSHING <b>(1.0 X 1.5 X 14GA)</b>	2
11	1/4X1-1/2	COTTER PIN	1
12	4K602	STRAIGHT ADAPTER <b>(08MJ X 08MOR)</b>	4
13	4K912	MALE TRACTOR TIP <b>(08FOR)</b>	2
14	4K619	HYDRAULIC HOSE - 134"	2
15	5J768	PIN <b>(1.0 X 5.50 H2)</b>	1
16	8J212	SPACER <b>(1.031 X 1.375 X 0.688)</b>	2
17	1D594	HAIR PIN COTTER .178 X 3-9/16	1
18	147072	PIN, SPRING SLOTTED 5/16 X 2	1
19	9J816	HOSE SUPPORT	1
20	1/8X1-1/2	COTTER PIN, ZP	1

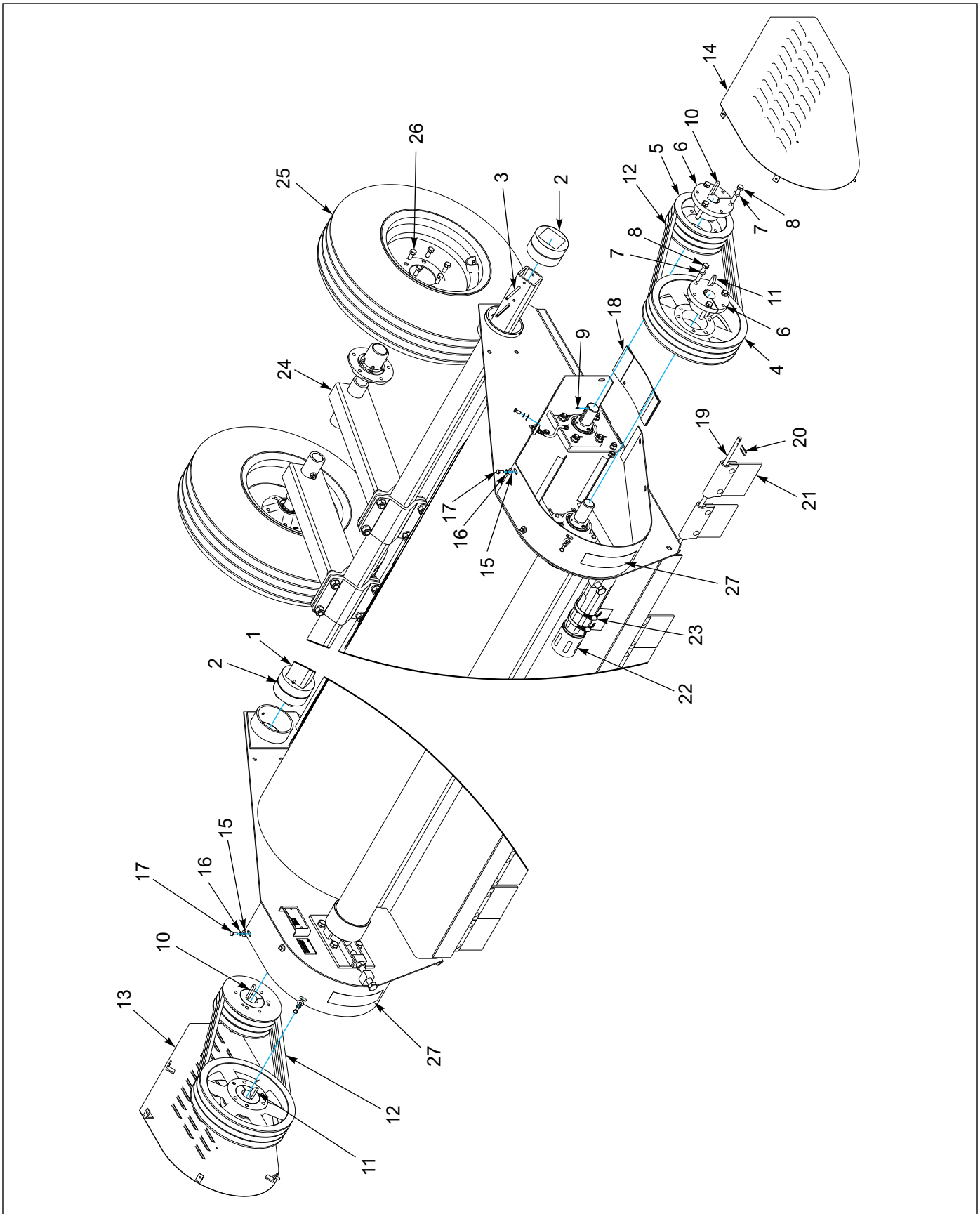

Figure 1-22: Pulley Guards

## Pulley Guards

ITEM	PART NUMBER	DESCRIPTION	QUANTITY	
			12'	15'
1	8J255	PVOT TUBE		1
1	8J192	PIVOT TUBE	1	
2	8J187	BEARING	2	2
3	5D954	ROLL PIN 5/16 X 4	4	4
4	5D328	PULLEY 3C SHEAVE 14.0 P.D.	2	2
5	5D329	PULLEY 3C SHEAVE 8.5 P.D.	2	2
6	6D927	E HUB W0 1 3/4 IN. BORE <b>(INCLUDES ITEMS 7 AND 8)</b>	4	4
7	1-861-010034-13	WASHER, LKG HLCL SPR, 1/2	12	12
8	6D744	CAPSCREW <b>(1/2-13 X 2-3/4 GR5, ZP)</b>	12	12
9	5D511	ROLL PIN <b>(1/8 X 1/2)</b>	2	2
10	5D479	KEY (C) <b>(SQ 0.375 X 2.313)</b>	2	2
11	5D508	WOODRUFF KEY	2	2
12	5D875	BELT SET W/INSTRUCTIONS <b>(SET OF 3 BELTS)</b>	2	2
13	4D575	BELT GUARD COVER RH WLDMT	1	1
14	4D539	BELT GUARD COVER, LH WLDMT	1	1
15	1-861-010032-09	WASHER, FLAT 5/16 W ZP/CD	8	8
16	1-861-010034-10	WASHER, LKG 5/16	6	6
17	1-654-010049-03	SCREW, HX CP 5/16-18 X 3/4, GR5	6	6
18	5D216	GUARD	2	2
19	5D302	ROD, SKIRT HANGER 15 FT.		2
19	5D301	ROD, SKIRT HANGER 12 FT.	2	
20	2C864	COTTER PIN 1/8 X 1	4	4
21	7D681	SKIRT, 6-1/8		28
21	7D680	SKIRT, 6-7/8	20	
22	8K349	MANUAL STORAGE CANISTER	1	1
23	8K350	HOSE CLAMP 4-1/2 IDEAL #5264	2	2
24	8J881	WHEEL ARM ASM <b>(SEE PAGE 1-36)</b>	2	4
25	6K926	WHEEL 8J790/NO TUBE/6J189 <b>(SEE PAGE 1-38)</b>	2	4
26	5C100	WHEEL BOLT 1/2-20 X 1 GR5, ZP	10	20
27	528934	REFLECTOR - YELLOW	2	2

## ILLUSTRATED PARTS LIST

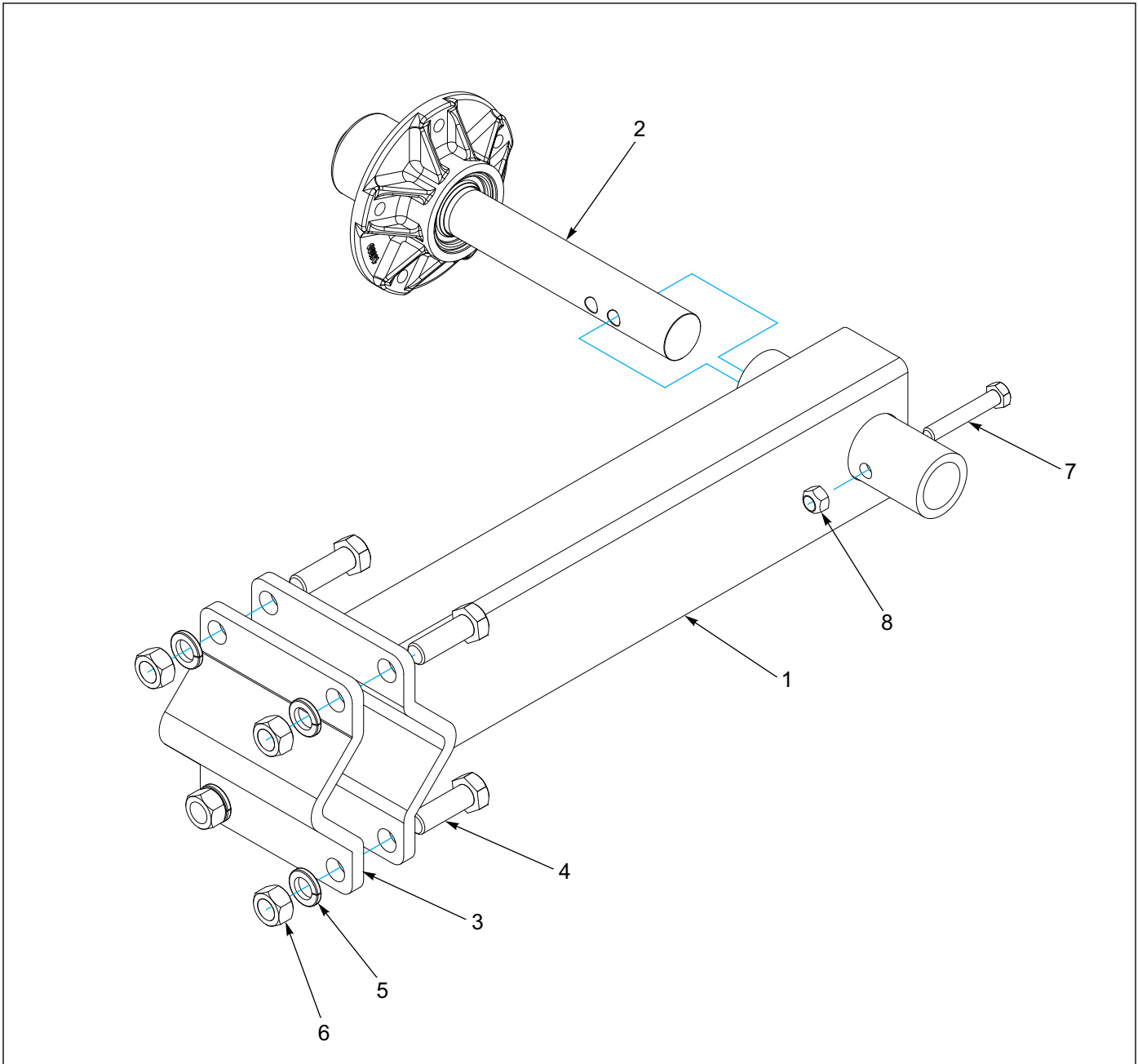

Figure 1-23: Wheel Arm Assembly

### Wheel Arm Assembly

ITEM	PART NUMBER	DESCRIPTION	QTY
	8J881	WHEEL ARM ASM	
1	8J880	WHEEL ARM	1
2	1K105	HUB & SPINDLE (SEE PAGE 1-37)	1
3	8J300	CLAMP PLATE	1
4	1-654-010061-06	SCREW, HXCP, 3/4-10UNC X 2-1/4, GR5	4
5	1-861-010034-17	WASHER, LKG, HLCL SPR, 3/4	4
6	1-512-010007-12	NUT, HEX 3/4-10 GR2, ZP	4
7	1-654-010055-09	SCREW, HX CP, 1/2-13UNC X 3, GR5	1
8	1-512-010005-09	NUT, HEX, SLFLKG, 1/2-13 GRB	1



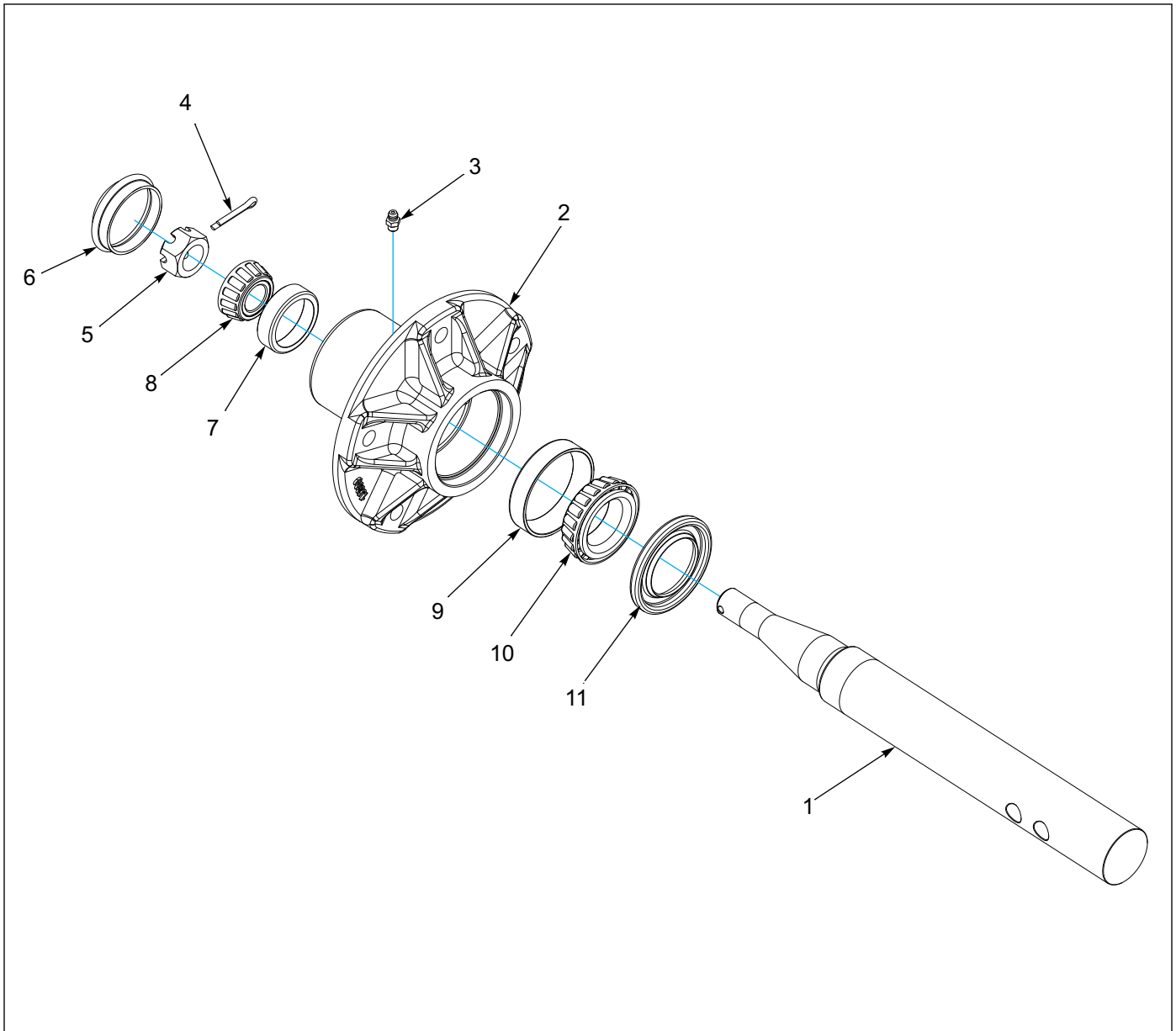
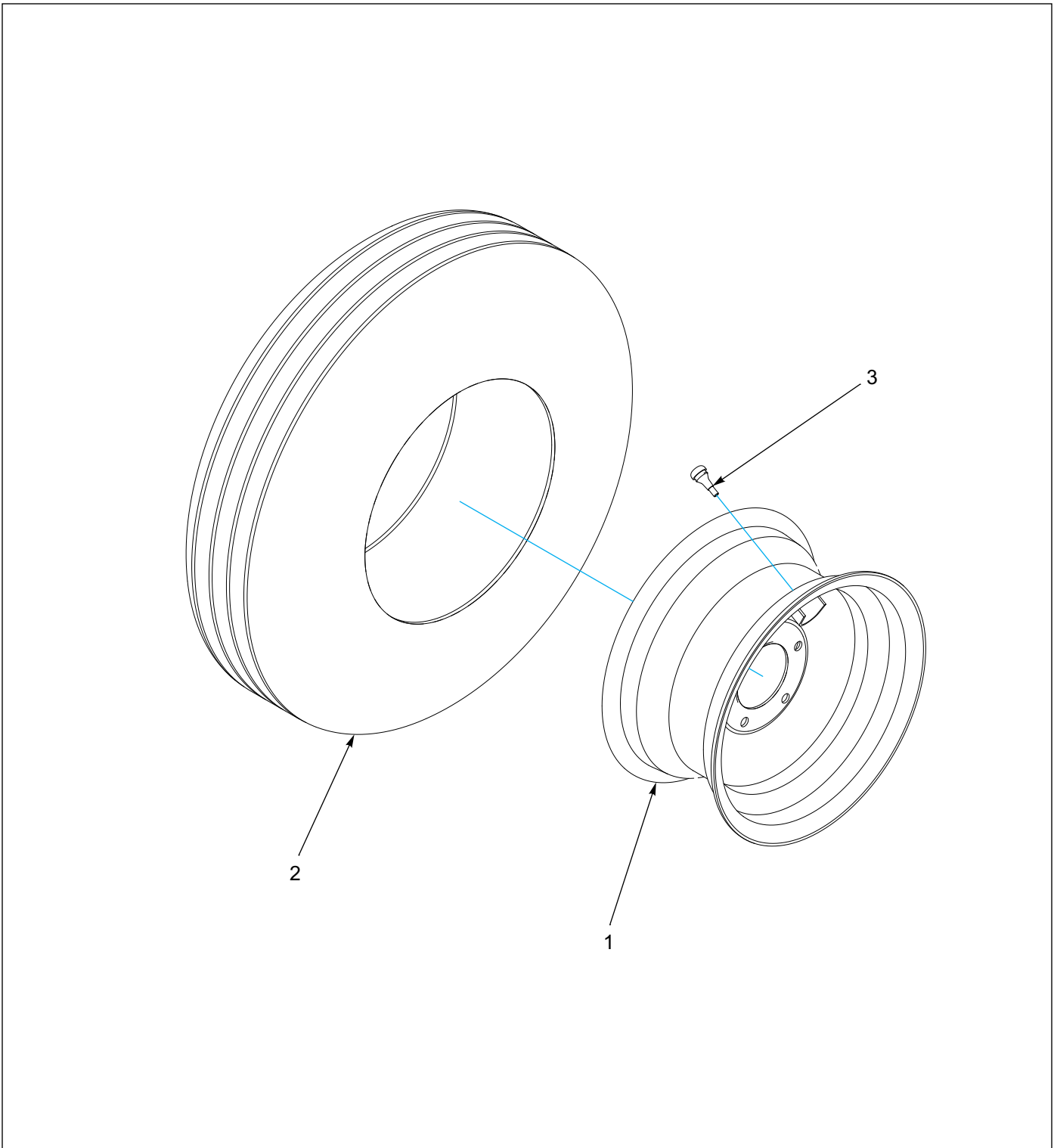

Figure 1-24: Hub and Spindle Assembly

### Hub and Spindle Assembly

ITEM	PART NUMBER	DESCRIPTION	QTY
	1K105	HUB & SPINDLE	
1	5J467	SPINDLE	1
2	1J390	WHEEL HUB - 5 BOLT (INCLUDES ITEM 3)	1
3	1-298-010001-1	ZERK FITTING 1/4 SAE	1
4	110-0344	5/32 X 1 COTTER PIN	1
5	3/4-16HSN	HEX SLOTTED NUT	1
6	1J463	HUB CAP	1
7	5C912	CUP, BEARING	1
8	5C911	CONE BEARING	1
9	5C479	CUP, BEARING	1
10	5C480	CONE, BEARING	1
11	1D273	SEAL	1



**Figure 1-25: Wheel and Tire Assembly**

**Wheel and Tire Assembly**

ITEM	PART NUMBER	DESCRIPTION	QTY
	6K926	WHEEL 8J790/NO TUBE/6J189	
1	6J189	WHEEL - 15 X 8LB - 5 BOLT	1
2	8J790	TIRE - 9.5 X 15 - 6 PLY	1
3	8J792	VALVE STEM-TUBELESS	1

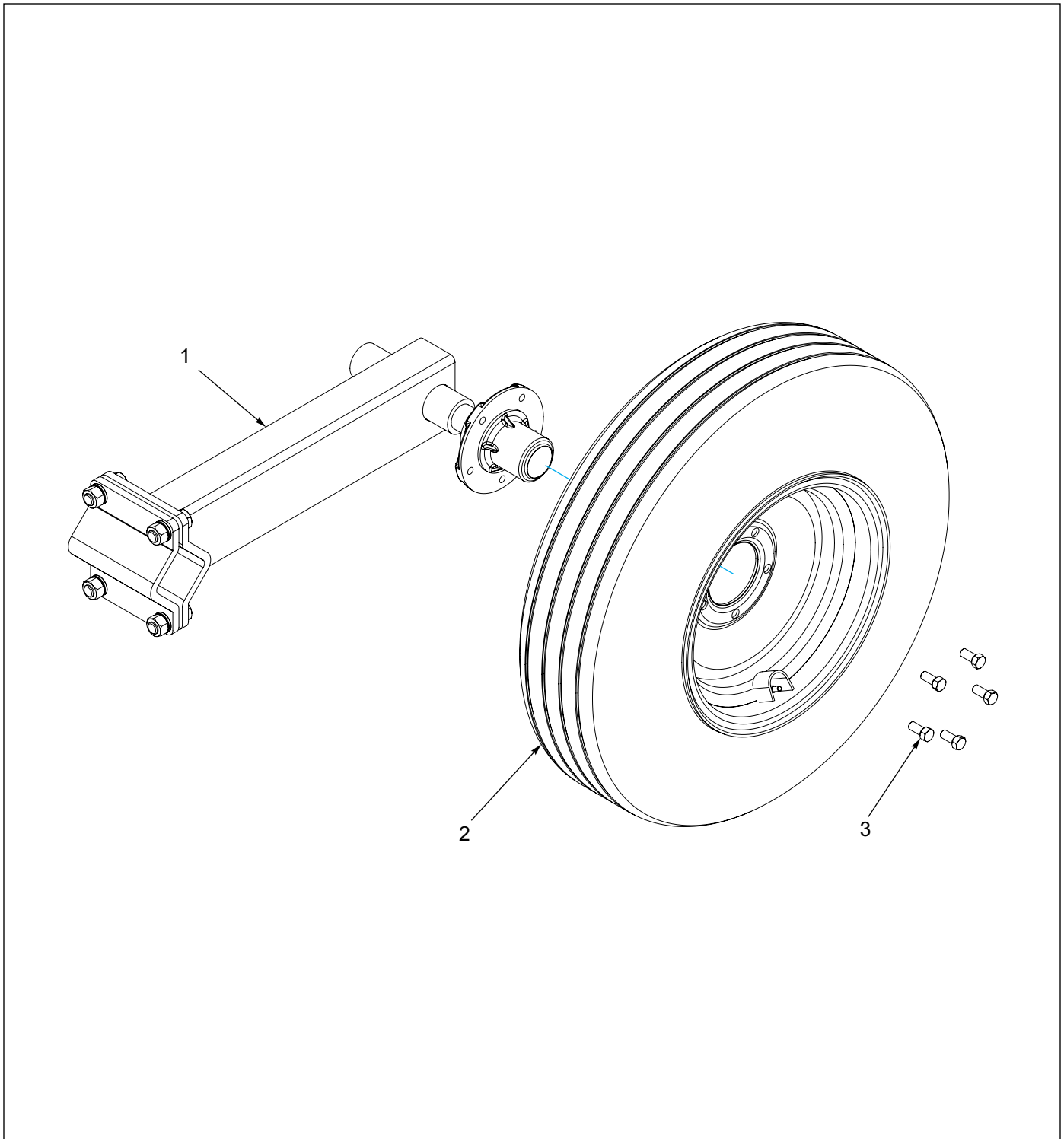

Figure 1-26: Wheel Kit, Auxiliary - Optional

### Wheel Kit, Auxiliary - Optional

ITEM	PART NUMBER	DESCRIPTION	QTY
	8J271	FLAIL AUXILIARY WHEEL KIT	
1	8J881	WHEEL ARM ASM (SEE PAGE 1-36)	1
2	6K926	WHEEL 8J790/NO TUBE/6J189 (SEE PAGE 1-38)	1
3	5C100	WHEEL BOLT 1/2-20 X 1 GR5, ZP	5

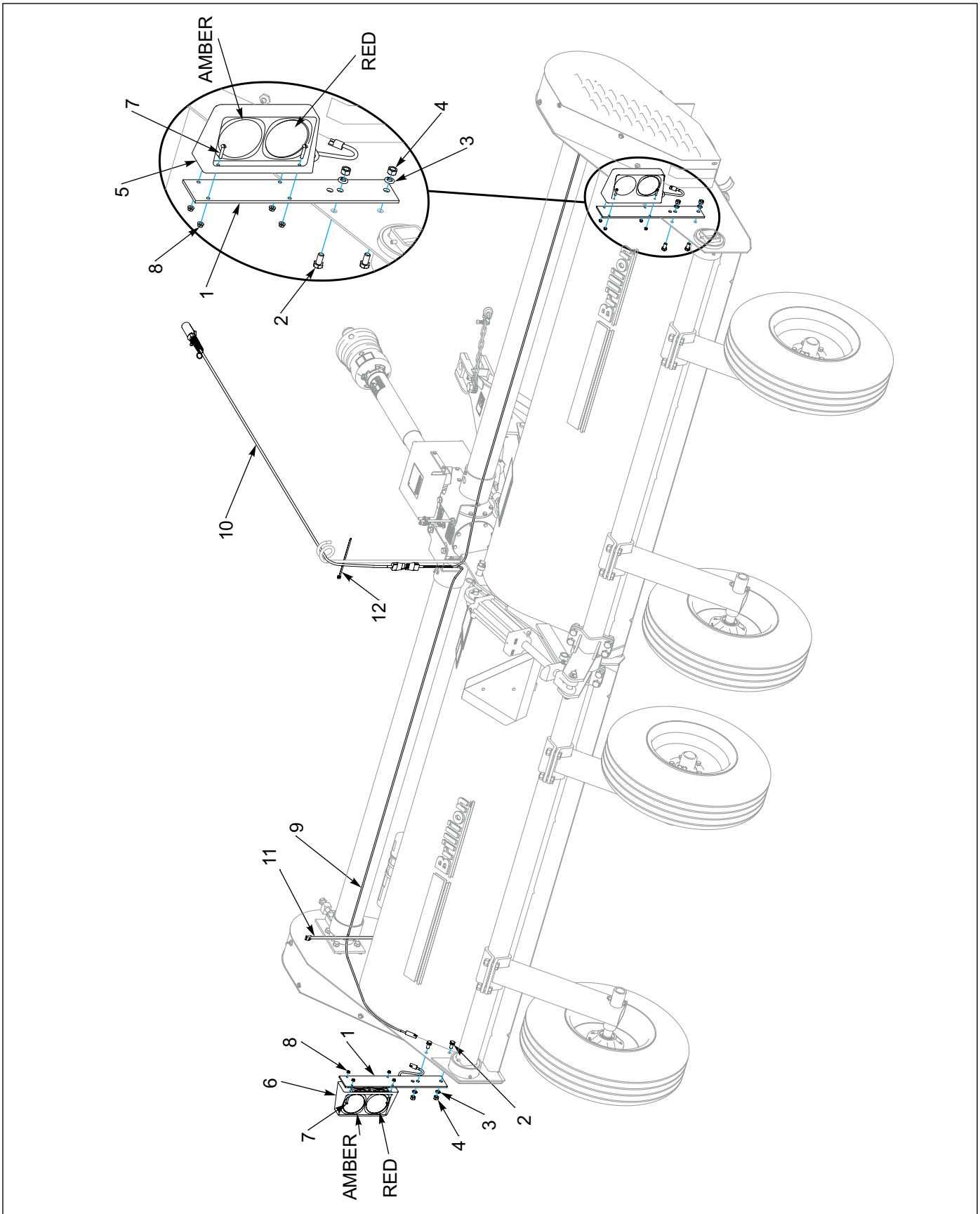

Figure 1-27: Warning Lights - 07/31/2013 and Prior

## Warning Lights - 07/31/2013 and Prior

ITEM	PART NUMBER	DESCRIPTION	QTY
1	4K871	MOUNTING STRAP	2
2	1-654-010055-01	SCR, HX CP 1/2-13UNC X 1, GR5	4
3	1-861-010034-13	WASHER, LKG HLCL SPR, 1/2	4
4	1-512-010007-09	NUT, HEX 1/2-13, ZP	4
5	4K772	LH DUAL LAMP (002600) (INSTALLED ON RH SIDE OF MACHINE)	1
6	4K773	RH DUAL LAMP (002601) (INSTALLED ON LH SIDE OF MACHINE)	1
7	4K782	HHCS, 1/4-20 X 1-1/4, ZP	8
8	108417	NUT SPIRAL 1/4-20HX FG	8
9	142757	AG HARNESS, WISHBONE 10'	1
10	4K936	10' AG HARNESS	1
11	105874	TIE, STRAP PLSTC 21.5-24 X .301	8
12	105-0228	TYWRAP 8IN LG TY-5272MX	4

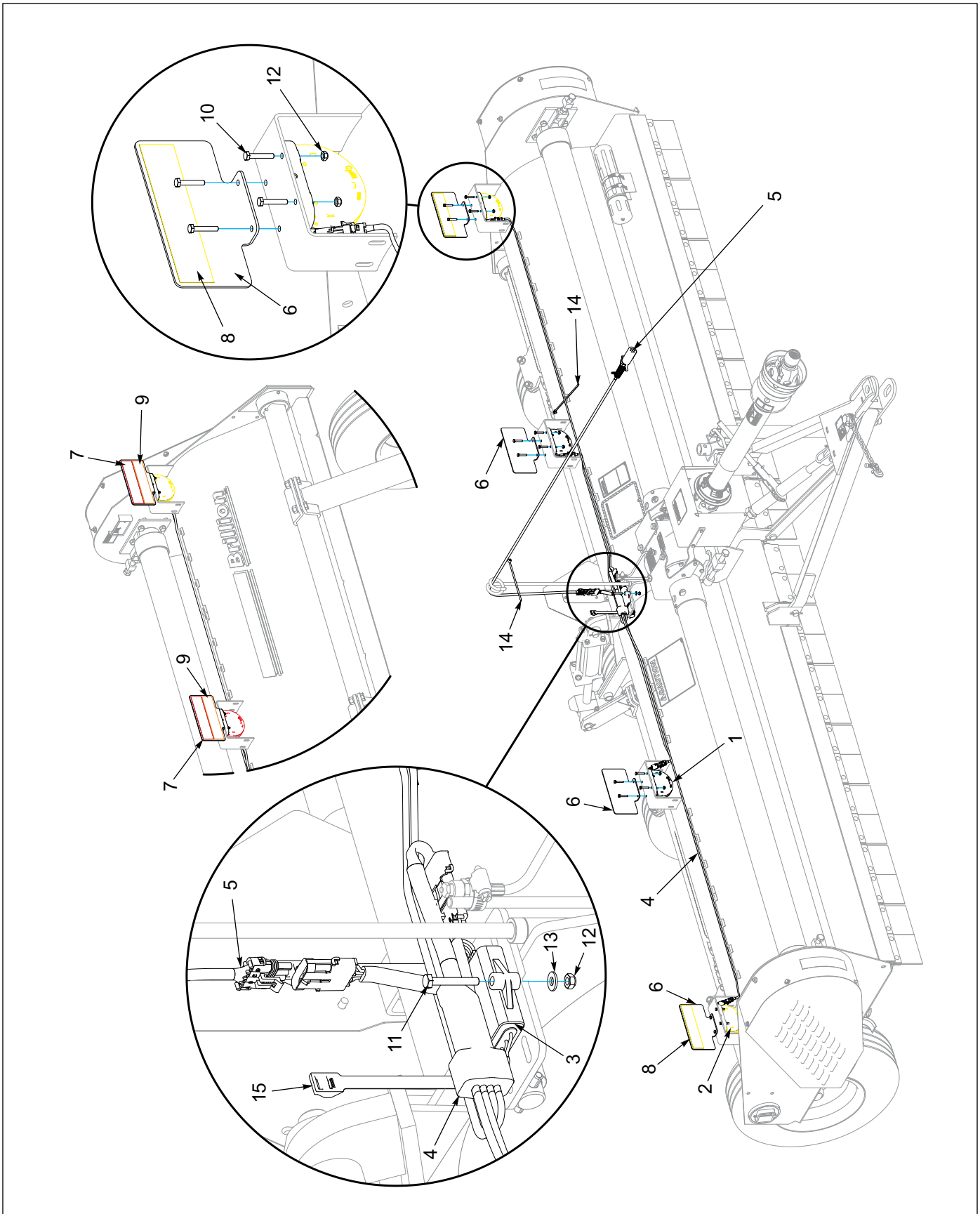

Figure 1-28: LED Warning Lights - 08/01/2013 and After

## LED Warning Lights - 08/01/2013 and After

ITEM	PART NUMBER	DESCRIPTION	QTY
1	174435	LAMP, AG RED SINGLE LED	2
2	174436	LAMP, AG AMBER SINGLE LED	2
3	174437	MODULE, AG FLASHER CONTROL	1
4	178513	HARNESS, LAMP 66 X 138	1
5	178515	HARNESS, 7PIN/4PIN WP, 15'	1
6	178521	PLATE, REFLECTIVE DECAL MOUNT	4
7	528933	REFLECTOR - RED	4
8	528934	REFLECTOR - YELLOW	2
9	528938	STRIP, ORANGE	4
10	1-654-010047-08	SCREW HX CP, 1/4-20UNC X 1-1/2, G5	16
11	1-654-010047-09	SCREW HX CP, 1/4-20UNC X 1-3/4, G5	2
12	1-512-010005-01	NUT, HEX, SLFLKG GRB 1/4-20	18
13	1-861-010032-06	WASHER, FLAT 1/4 N ZP/CD	2
14	105-0228	TYWRAP 8IN LG TY-5272MX	30
15	105874	TIE, STRAP PLSTC 21.5-24 X .301	4

## ILLUSTRATED PARTS LIST

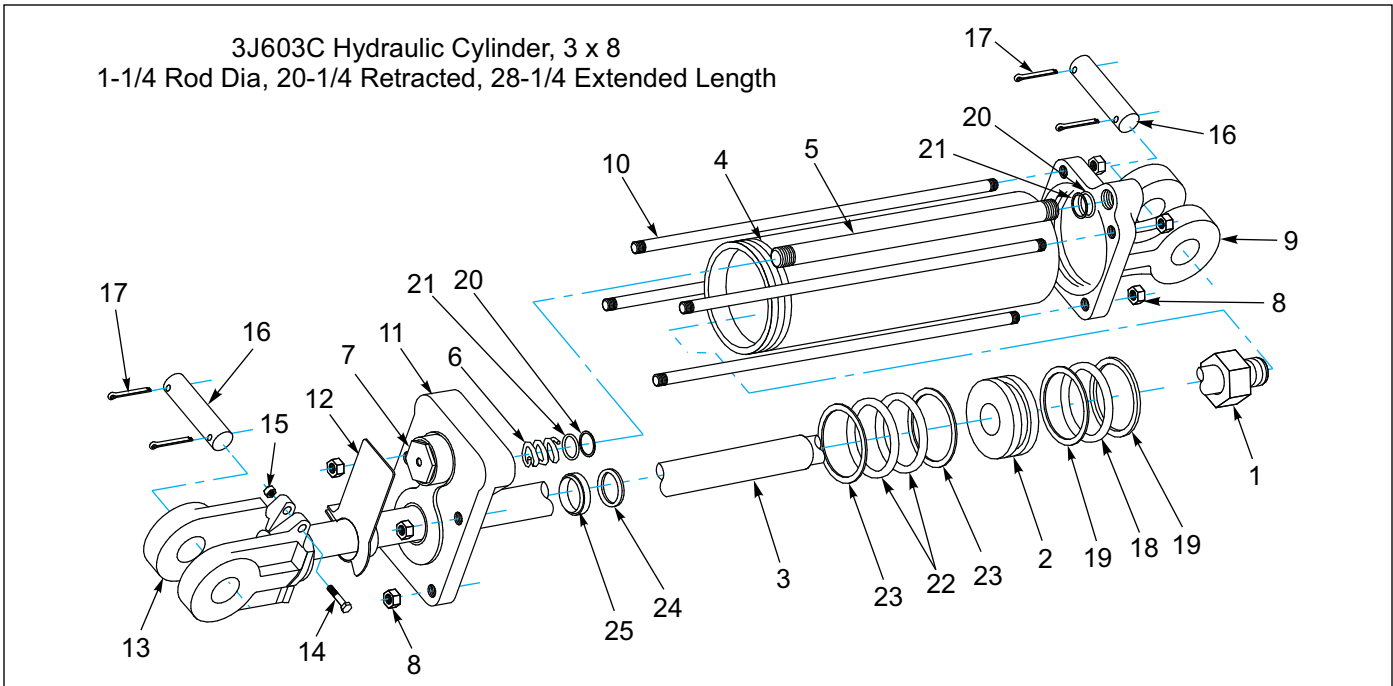

Figure 1-29: Hydraulic Cylinder, 3 X 8 - Cross

### Hydraulic Cylinder, 3 x 8 - Cross

ITEM	PART NUMBER	DESCRIPTION	QTY
	3J603	HYD CYLINDER 3 X 8	
1	5K684	NUT	1
2	5K685	PISTON	1
3	5K686	ROD	1
4	5K687	TUBE	1
5	5K688	FEED TUBE	1
6	5K689	SPRING	1
7	5K690	CARTRIDGE ASSEMBLY	1
8	5K691	NUT	8
9	5K692	BASE CLEVIS	1
10	5K693	TIE ROD	4
11	5K694	HEAD	1
12	5K695	ACTUATOR ASSEMBLY	1
13	5K696	ROD CLEVIS	1
14	5K697	CAPSCREW	1
15	5K698	NUT	1
16	7J067	CLEVIS PIN, 1 X 4	2
17	110-4224	PIN,COTTER-3/16 X 2IN LG	4
18	----	O-RING	1
19	----	BACK-UP RING	2
20	----	BACK-UP RING	2
21	----	O-RING	2
22	----	O-RING	2
23	----	BACK-UP RING	2
24	----	U-CUP	1
25	----	WIPER	1
26	5K699	SEAL KIT (INCLUDES ITEMS 18 - 25)	



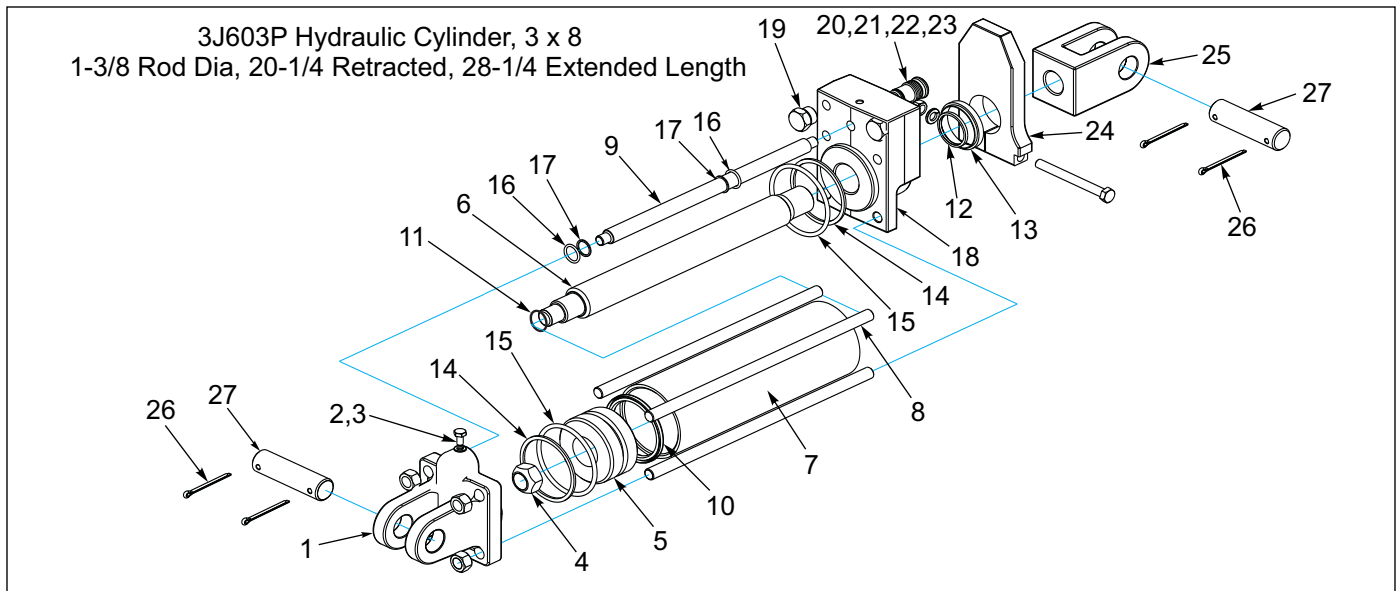

Figure 1-30: Hydraulic Cylinder, 3" X 8 - Prince

### Hydraulic Cylinder, 3 x 8 - Prince

ITEM	PART NUMBER	DESCRIPTION	QTY
	3J603	HYDRAULIC CYLINDER 3 X 8	
1	-----	BUTT (BASE)	1
2	-----	NYLTITE SEAL	1
3	3J730	CAPSCREW	1
4	6D918	LOCK NUT (3/4-16)	1
5	-----	PISTON	1
6	-----	PISTON, ROD	1
7	3J719	TUBE, CYL	1
8	3J721	TIE ROD	4
9	3J720	MANIFOLD TUBE	1
10	-----	URETHANE SEAL	1
11	-----	O-RING	1
12	-----	U-CUP	1
13	-----	WIPER	1
14	-----	BACK-UP WASHER	2
15	-----	O-RING	2
16	-----	O-RING	2
17	-----	BACK-UP WASHER	2
18	7J050	GLAND (WITH PORTS REQUIRING O-RINGS)	1
18	3J726	GLAND (WITH PIPE THREADS)	1
19	1-007-010025	PLUG, 3/4-16 O-RING BOSS	1
20	9J638	VALVE ASSEMBLY	1
21	-----	O-RING	1
22	-----	O-RING	1
23	-----	BACK-UP WASHER	1
24	9J804	STRIKER PLATE ASM-5K695 - DEA	1
25	-----	CLEVIS ASSEMBLY	1
26	110-4224	PIN, COTTER-3/16 X 2IN LG	4
27	5J650	CLEVIS PIN	2
28	3J729	SEAL KIT (INCLUDES ITEMS 10-17)	



## Numerical Index

### Numerics

1/4X1-1/2	1-9, 1-33	1-654-010049-05	1-3
1/8X1-1/2	1-33	1-654-010051-03	1-25
1-007-010025	1-45	1-654-010051-05	1-5, 1-23, 1-25
100829	1-9	1-654-010051-06	1-21
103464	1-5	1-654-010055-01	1-6, 1-11, 1-41
104032	1-3, 1-5, 1-21	1-654-010055-02	1-11
105-0228	1-41, 1-43	1-654-010055-04	1-18, 1-19
105874	1-41, 1-43	1-654-010055-09	1-36
1-076-010002	1-23, 1-25	1-654-010059-01	1-5
108417	1-41	1-654-010059-03	1-5
110-0344	1-37	1-654-010059-05	1-5
110-0351	1-11	1-654-010061-06	1-36
110-4224	1-9, 1-44, 1-45	1-654-010070-04	1-17
118-1241	1-5	174435	1-43
1-298-010001-1	1-11, 1-37	174436	1-43
141433	1-9	174437	1-43
142757	1-41	178513	1-43
147072	1-33	178515	1-43
1-512-010005-01	1-43	178521	1-43
1-512-010005-09	1-17, 1-18, 1-19, 1-36	1-861-010032-06	1-43
1-512-010005-19	1-9	1-861-010032-09	1-3, 1-35
1-512-010007-07	1-5, 1-21	1-861-010032-11	1-5, 1-21
1-512-010007-09	1-6, 1-11, 1-41	1-861-010032-15	1-19
1-512-010007-12	1-5, 1-33, 1-36	1-861-010032-19	1-5
1-654-010047-08	1-43	1-861-010032-24	1-9
1-654-010047-09	1-43	1-861-010034-10	1-35
1-654-010049-01	1-5	1-861-010034-11	1-5, 1-21, 1-23, 1-25
1-654-010049-03	1-21, 1-35	1-861-010034-13	1-6, 1-35, 1-41
		1-861-010034-14	1-11

## NUMERICAL INDEX

---

1-861-010034-15	1-5, 1-11, 1-21	3J726	1-45
1-861-010034-17	1-33, 1-36	3J729	1-45
1D134	1-27, 1-29, 1-31	3J730	1-45
1D273	1-37	3J880	1-9
1D594	1-33	3K079	1-5
1D759	1-23, 1-25	3K080	1-5
1D991	1-21	3K083	1-21
1J390	1-37	3K089	1-21
1J463	1-37	3K090	1-21
1K105	1-36, 1-37	3K098	1-5, 1-21, 1-23
1K169	1-11, 1-12	3K099	1-5, 1-21, 1-25
1K170	1-11, 1-13	3K343	1-23, 1-25
1K171	1-11, 1-12	3K344	1-25
1K172	1-11, 1-13	3K345	1-23
1K305	1-5, 1-11, 1-21	3K346	1-23
1K306	1-5, 1-11	3K364	1-25
1K307	1-5, 1-11	3K365	1-23
1K308	1-5	3K366	1-23, 1-25
1K309	1-11	3K368	1-23, 1-25
208499	1-31	3K369	1-23, 1-25
2C290	1-11	3K370	1-23
2C733	1-21	3K371	1-21
2C864	1-35	3K372	1-23, 1-25
2J099	1-3, 1-21	3K373	1-23, 1-25
2P151	1-3	3K374	1-25
2P775	1-21, 1-29	3K375	1-23, 1-25
2P776	1-29	3K381	1-23, 1-25
2P777	1-29	3K382	1-23
2P778	1-29	3K383	1-23, 1-25
2P779	1-29	3K384	1-23, 1-25
2P780	1-29	3K385	1-23, 1-25
2P781	1-29	3K386	1-23, 1-25
3/4-16HSN	1-37	3K644	1-5
3D978	1-21	3K648	1-5
3J603	1-33, 1-44, 1-45	3K664	1-5
3J719	1-45	3K706	1-9
3J720	1-45	4C437	1-11
3J721	1-45	4D528	1-6

4D529	1-11	5D045	1-19
4D538	1-11	5D052	1-18
4D539	1-35	5D053	1-18, 1-19
4D543	1-9	5D054	1-18
4D557	1-9	5D076	1-19
4D564	1-11	5D183	1-18
4D575	1-35	5D216	1-35
4D579	1-11	5D301	1-35
4D581	1-11	5D302	1-35
4D602	1-12, 1-13, 1-16, 1-18	5D328	1-35
4D620	1-6	5D329	1-35
4D645	1-11	5D333	1-18
4D957	1-33	5D410	1-5
4D983	1-9	5D411	1-5
4K031	1-3	5D479	1-35
4K036	1-3	5D508	1-35
4K039	1-3	5D511	1-35
4K602	1-33	5D875	1-35
4K619	1-33	5D954	1-35
4K772	1-41	5J467	1-37
4K773	1-41	5J572	1-33
4K782	1-41	5J650	1-45
4K871	1-41	5J768	1-33
4K912	1-33	5K684	1-44
4K936	1-41	5K685	1-44
5000	1-5, 1-11	5K686	1-44
528933	1-3, 1-43	5K687	1-44
528934	1-3, 1-35, 1-43	5K688	1-44
528938	1-3, 1-43	5K689	1-44
5C100	1-35, 1-39	5K690	1-44
5C479	1-37	5K691	1-44
5C480	1-37	5K692	1-44
5C911	1-37	5K693	1-44
5C912	1-37	5K694	1-44
5D006	1-3	5K695	1-44
5D019	1-3, 1-21	5K696	1-44
5D020	1-3, 1-21	5K697	1-44
5D044	1-19	5K698	1-44

## NUMERICAL INDEX

---

5K699	1-44	8J294	1-31
6D744	1-35	8J295	1-31
6D918	1-45	8J297	1-27, 1-29, 1-31
6D927	1-35	8J300	1-36
6J189	1-38	8J754	1-17
6K458	1-9	8J755	1-17
6K901	1-27	8J756	1-17
6K907	1-27, 1-29	8J757	1-11, 1-14
6K908	1-27, 1-29	8J758	1-11, 1-15
6K926	1-35, 1-38, 1-39	8J759	1-11, 1-14
7C076	1-33	8J760	1-11, 1-15
7D019	1-21	8J790	1-38
7D020	1-21	8J792	1-38
7D213	1-5	8J807	1-12, 1-13, 1-14, 1-15, 1-17
7D216	1-5	8J880	1-36
7D680	1-35	8J881	1-35, 1-36, 1-39
7D681	1-35	8J930	1-19
7J050	1-45	8K349	1-35
7J067	1-44	8K350	1-35
7J237	1-9	8K987	1-27, 1-29
8D099	1-9	9C594	1-3, 1-21
8D350	1-11	9D912	1-12, 1-13, 1-14, 1-15, 1-16
8D387	1-3	9D913	1-12, 1-13, 1-14, 1-15, 1-16
8J187	1-33, 1-35	9D919	1-11, 1-16
8J191	1-33	9D920	1-11, 1-16
8J192	1-35	9J205	1-27, 1-29, 1-31
8J206	1-9	9J206	1-21
8J212	1-33	9J638	1-45
8J220	1-5	9J804	1-45
8J223	1-5	9J816	1-33
8J255	1-33, 1-35	9K726	1-21, 1-31
8J266	1-5	9K727	1-27
8J268	1-33	9K728	1-31
8J271	1-39	9K729	1-27, 1-29, 1-31
8J273	1-3	9K730	1-27, 1-29
8J287	1-31		
8J291	1-31		
8J292	1-31		

# Chapter 3

## Glossary

---

For clarity this glossary of industry standard abbreviations and their definitions are provided.

For additional information, See "Instructions for Ordering Parts" on page 1-1.

### A

---

**ASSY** .....Assembly

### B

---

**BHSC** .....Button Head Socket Cap  
**BLK** .....Black  
**BLKHD** .....Bulkhead  
**BLNCE** .....Balance

### C

---

**CONN** .....Connector  
**CP** .....Cap  
**CRG** .....Carriage  
**CVR** .....Cover  
**CYD OR CYL** .....Cylinder

### D

---

**DBL** .....Double  
**DEG** .....Degree  
**DIA** .....Diameter

### F

---

**FHCS** .....Flanged Head Cap Screw  
**FHHCS** .....Flanged Hex Head Cap Screw  
**FL OR FLG** .....Flange  
**FLT** .....Flat  
**FRT** .....Front

### G

---

**GA** .....Gauge  
**GR5** .....Grade 5  
**GR8** .....Grade 8

### H

---

**HHCS** .....Hex Head Cap Screw  
**HD** .....Head  
**HCSKT** .....Hex Socket  
**HSFC** .....Hex Socket Flat Countersunk  
**HX** .....Hex  
**HYD** .....Hydraulic

### I

---

**ID** .....Inside Diameter  
**IND** .....Indicator  
**INT** .....Interior

### L

---

**LH** .....Lefthand  
**LIM** .....Limit  
**LKG OR LOCK** .....Locking  
**LWR** .....Lower

### N

---

**NSS** .....Not Serviced Separately  
**NYL** .....Nylon

### O

---

**OD** .....Outside Diameter  
**ORFS OR ORS** .....O-Ring Seal  
**ORP OR ORB** .....O-Ring Boss

### R

---

REFLECTV .....	Reflective
RH .....	Righthand
RND OR RD .....	Round
ROT .....	Rotation
RTNR .....	Retainer

### S

---

SER .....	Series
SGL .....	Single
SHCS .....	Socket Head Cap Screw
SHLD .....	Shield
SKT .....	Socket
SLFLKG .....	Selflocking
SOC .....	Socket
SPR .....	Spring
SQ .....	Square
SRTD .....	Serrated
SSCR .....	Setscrew
SST .....	Stainless Steel
STD .....	Standard

### U

---

UNC .....	Unified Coarse Thread
UNF .....	Unified Fine Thread
UPR .....	Upper

### W

---

WHL .....	Wheel
WLD OR WLDMT .....	Weldment
WSHR .....	Washer

### Z

---

ZP .....	Zinc Plate
----------	------------



**Document Control Revision Log:**

Date	Revision	Improvement(s) Description and Comments
08/2012	F-629-R1	Initial Release
06/2013	F-629-R2	Added LED Warning Lights



**Intertek**

Equipment from Landoll Company, LLC is built to exacting standards ensured by ISO 9001 registration at all Landoll manufacturing facilities.

**Flail Shredder 12 and 15 ft  
Models - 1446, 1446-1, 1806, and 1806-1  
Series - FS, FSC, and FSB  
Parts Manual**

Re-Order Part Number F-629

**LANDOLL COMPANY, LLC**

1900 North Street

Marysville, Kansas 66508

(785) 562-5381

**800-428-5655 ~ WWW.LANDOLL.COM**



Copyright 2020. Landoll Company, LLC

"All rights reserved, including the right to reproduce this material or portions thereof in any form."