

SETTING-UP AND OPERATING MANUAL

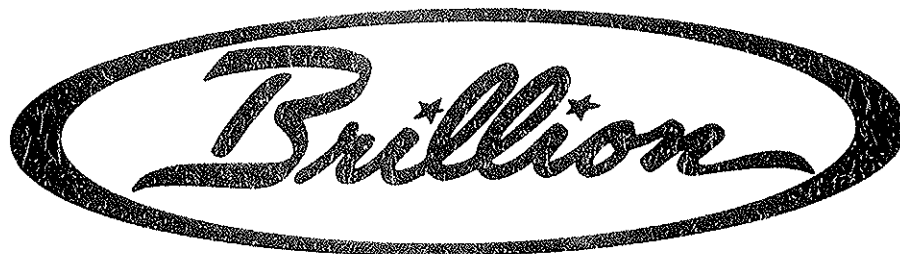

S-TINE CULTIVATOR-INCORPORATOR

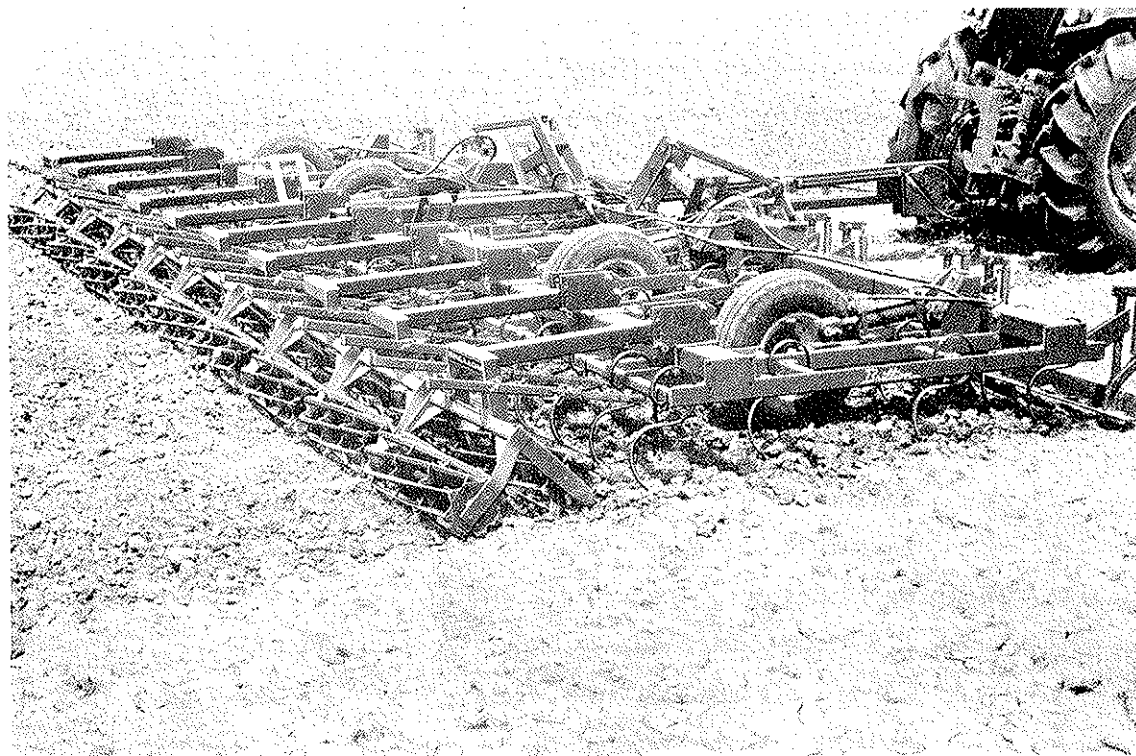

MODELS: C-2381 THRU C-3241
CS-2381 THRU CS-3241
CH-2381 THRU CH-3241
CSH-2381 THRU CSH-3241



BRILLION IRON WORKS
BRILLION, WISCONSIN 54110

CONTENTS

	Page
Introduction - - - - -	3
Location Reference - - - - -	3
Parts Ordering - - - - -	3
Safety Suggestions - - - - -	4
Operating Instructions - - - - -	5
Machine Preparation - - - - -	5
Bleeding Depth Control Cylinders - - - - -	5
Bleeding Wing Lift Cylinders - - - - -	6
Hitch - - - - -	6
Depth Stop - - - - -	6
Side-to-Side Leveling - - - - -	7
Rephasing - - - - -	7
Transport - - - - -	7
Working Speed - - - - -	9
Leveling Board Adjustments - - - - -	9
Chemical Incorporation - - - - -	9
Rolling Harrow Adjustments - - - - -	10
Maintenance - - - - -	11
Fasteners - - - - -	11
Tires - - - - -	11
Lubrication - - - - -	11
Shipping Bundles - - - - -	12
C & CS Models - - - - -	12
CH & CSH Models - - - - -	13
Rolling Harrows - - - - -	15
Leveler Boards - - - - -	15
Setting Up Instructions - - - - -	16
Rolling Harrow Installation - - - - -	36
Rock Shield Installation - - - - -	40
Leveler Board Installation - - - - -	41
Rear Hitch Installation - - - - -	41
Specifications - - - - -	45

INTRODUCTION

Your Brillion Cultivator-Incorporator is built with the best materials and workmanship available. It has been designed to give years of trouble-free operation. Proper care and operation will insure that you receive the service and long life built into this machine.

Study this manual carefully before attempting to assemble or operate the machine. A special section, "Setting Up Instructions", is included.



This safety alert symbol is used to call your attention to instructions concerning personal safety. Federal law requires you to explain the safety and operating instructions furnished with this machine to all employees before they are allowed to operate the machine. These must be repeated to the employees at the beginning of each season. Be sure to observe and follow the instructions for the safety of anyone operating or near the machine.

Location Reference

Right hand, left hand, and forward designations are those related to the operator when sitting in the operating position.

Parts Ordering

When ordering parts for this machine, include the complete model number and serial number. Refer to the name plate on the right rear hinge of the center section. Please record these numbers upon taking delivery of the unit.

Cultivator-Incorporator Model _____

Serial Number _____

Date Purchased _____

Be sure to read the warranty card which is shipped with the machine. Return the proper portion of the card for recording at the factory.



SAFETY SUGGESTIONS

Investigation has shown that nearly 1/3 of all farm accidents are caused by careless use of machinery. You can do your part in improving safety by observing the following suggestions. Insist that all people working with you or for you abide by them.

1. Do not stand between the tractor and implement when attaching or detaching implement unless both are not moving.
2. Do not fold or unfold the wings or operate the machine without first bleeding air from the hydraulic systems.
3. Do not allow anyone near the machine when folding or unfolding the wings.
4. Do not make adjustments or lubricate machine while it is in motion.
5. Do not allow anyone to ride on tractor or machine.
6. Relieve pressure in hydraulic lines before uncoupling hydraulic hoses from tractor. On most tractors this can be done by operating valves after engine is stopped.
7. Always use transport locks for center frame wheels and for wings when transporting machine.
8. Lower machine to ground when not in use.
9. Block machine so it will not roll when unhitched from tractor.
10. Do not transport at speeds over 10 mph.
11. Avoid sudden stops or turns when transporting because weight of machine may cause operator to lose control of tractor. Use a tractor heavier than machine. Do not allow tractor drawbar to swing when transporting.
12. Use caution when towing behind articulated steering tractors; fast or sharp turns may cause the machine to slip sideways.
13. Securely block machine when working on or under it to prevent injury in case of hydraulic failure or inadvertent lowering by another person.
14. Machine is drawbar light when complete rolling harrow assembly is installed. All cylinders must be retracted (tines on ground and wings lowered) before machine is unhitched from tractor. Use jack on rear of center frame.

OPERATING INSTRUCTIONS

Machine Preparation

A drawbar jack is provided as standard equipment. When rolling harrows are installed, machine is drawbar light and the jack is used at the rear of the center frame. When attaching machine to tractor, slight extension of depth control cylinders will raise front tines off ground and allow hitch to be raised or lowered using jack.

Hydraulic oil capacity of the cultivator-incorporator is approximately 6.25 gallons divided as follows:

4" x 24" cylinders	1.31 gallons each
5" x 8" cylinder	0.68 gallons
4-3/4" x 8" cylinder	0.61 gallons
4-1/2" x 8" cylinder	0.55 gallons
4" x 8" cylinder	0.44 gallons
Hoses	1.16 gallons
Tubes	0.19 gallons

Clean hose fittings before connecting to tractor. It is also necessary during initial operation to watch tractor oil level closely to avoid damage.

Depth control is accomplished by a system of four cylinders in series. Be sure they are connected so that flow is from largest bore cylinder to smallest in decreasing size. Also, the rod end of the first cylinder must be connected to the anchor end of the second, etc. See hydraulic diagram on page 22.

Bleeding Depth Control Cylinders

For machine to operate at a uniform depth, all air must be removed from the series circuit. The following procedure is suggested.

1. With all hoses and tubes connected, support all four depth control cylinders as nearly vertical as possible, with rod ends upward. (Do not secure by rod or rod end clevis as cylinders will be extended in following operations.)

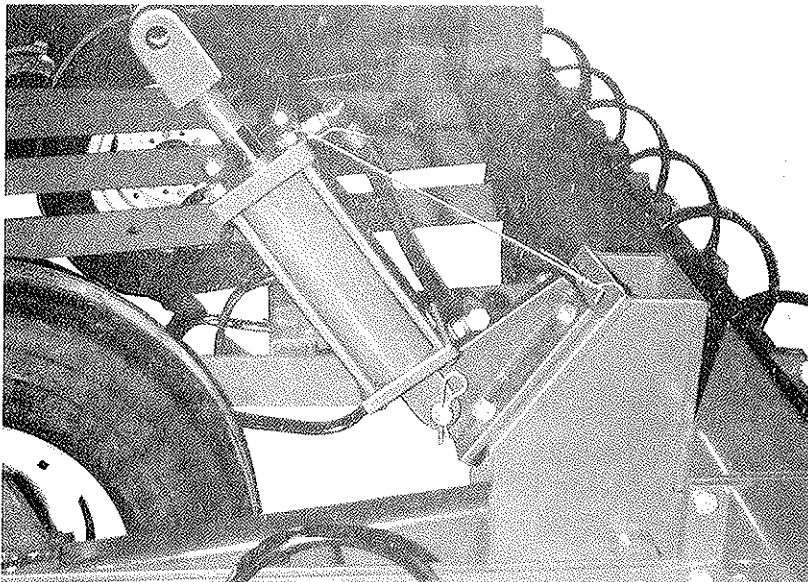

FIGURE 1

2. Activate the hydraulic system until all rods are fully extended.
3. Cycle the cylinders from fully extended to fully retracted at least two times, pausing at full extension about 30 seconds.
4. Fully extend cylinders one more time and allow oil to flow through system about one minute.
5. Reinstall cylinders between lugs and wheel arms.
6. Depth control circuit should not be opened after this. If parts are removed and air enters system, circuit must be bled again.

Bleeding Wing Lift Cylinders



Raise the wings partially, and then lower them again. It is important to do this 7 or 8 times before the wings are raised 90°. The wings depend upon the passage of oil through a flow restrictor to keep them from free-falling. If the cylinders are not full of oil, the wings may drop and damage the machine.

The two wings are not tied together, and one may raise before the other. Both wings should raise before either goes over 90°.

If it becomes necessary to drain the oil from one or more cylinders, it is important to bleed the air out of the system before operating.

Hitch

Position the hitch on the drawbar so the machine is level (front-to-rear) in operating position.

Depth Stop

The 5" diameter master cylinder (located on the left side of the center frame) controls operating depth of the entire machine. When the desired depth is obtained, slide the depth stop along the cylinder rod, depressing the plunger on top of the cylinder, and tighten the clamp bolt.

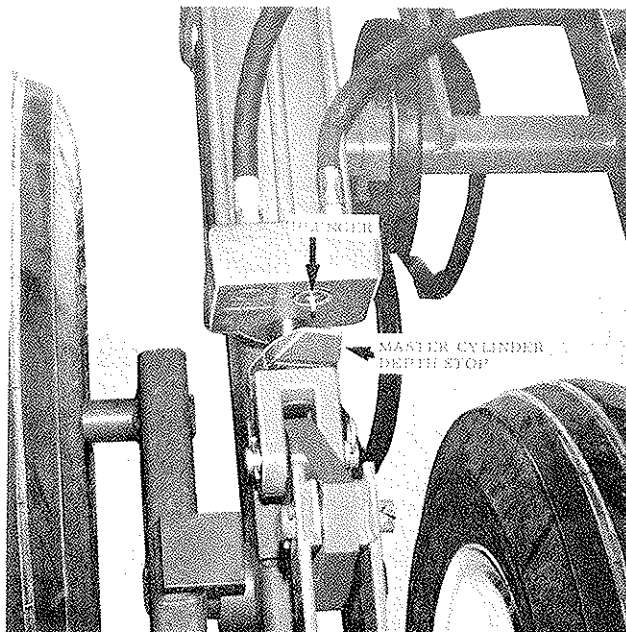

FIGURE 2

Side-To-Side Leveling

Consistent cultivating depth is maintained along the width of the machine by operating properly bled cylinders. If additional leveling is necessary, 1/8" and 1/4" shims (provided) may be used under the bolt-on cylinder lugs. Shims under a lug will reduce the cultivating depth of that section.

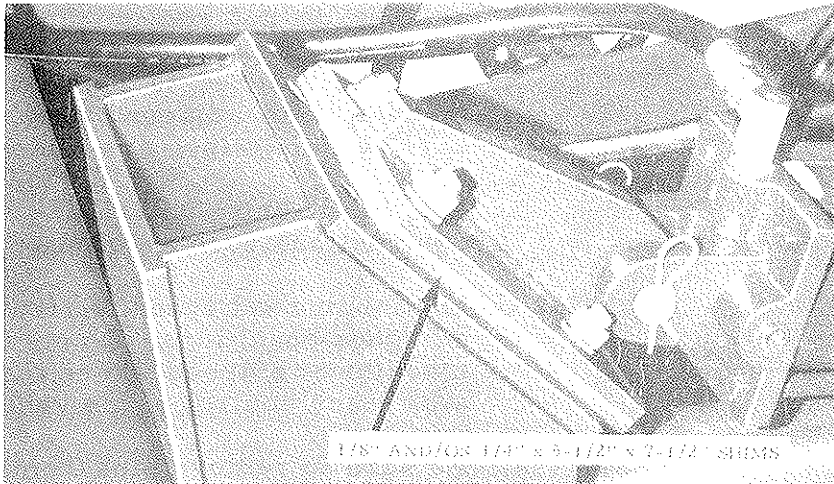

FIGURE 3

Rephasing

Occasionally, machine should be raised completely out of the ground and lift lever on tractor held for a few seconds. This will rephase depth control cylinders and insure uniform working depth of center section and wings.

Transport

To prepare a machine for transport, raise it fully out of the ground and then fold the wings. Lock wing lift links together. Then pin the transport lock tubes and links together on each of the center frame wheel assemblies.

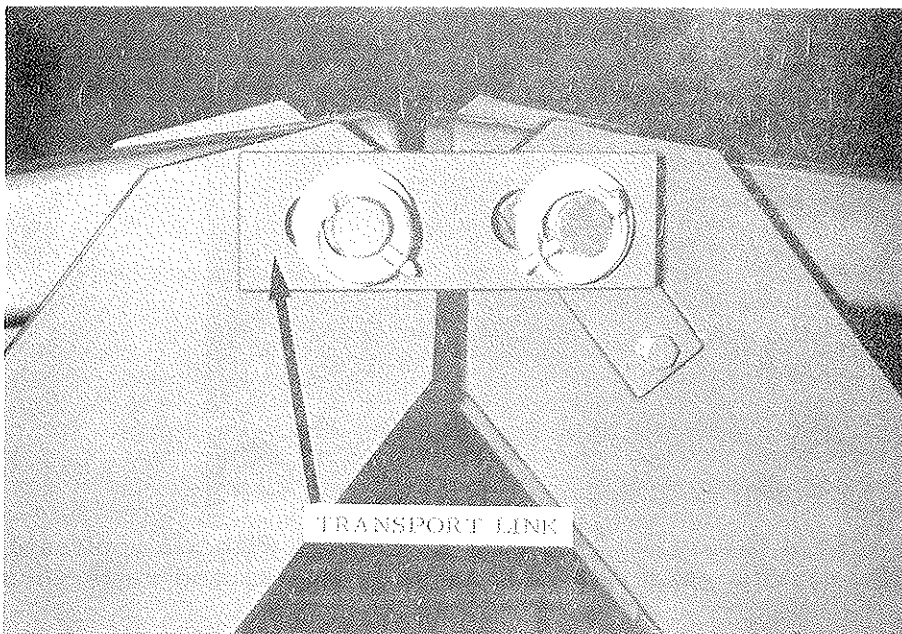

FIGURE 4

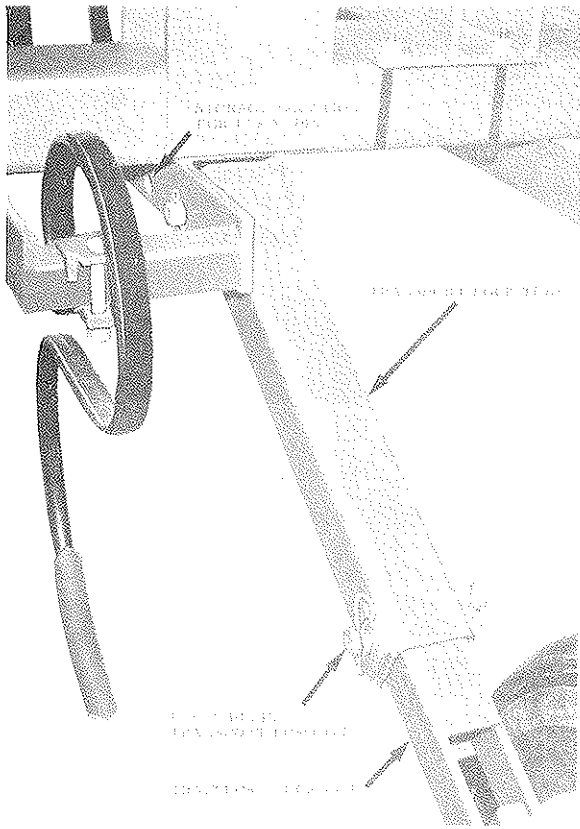

FIGURE 5



CAUTION

1. If rolling harrows are attached, but not being used (that is, supported so they do not run on the ground) each outside harrow on center frame must be lowered to prevent interference with adjacent wing rolling harrow when wings are folded.
2. Be sure machine will clear overhead obstructions such as wires.
3. Maximum road speed is 10 mph under good conditions. Do not tow the machine at a speed where the operator loses control of his vehicle.
4. Be sure to remove pins from transport position before attempting to lower machine or wings hydraulically.

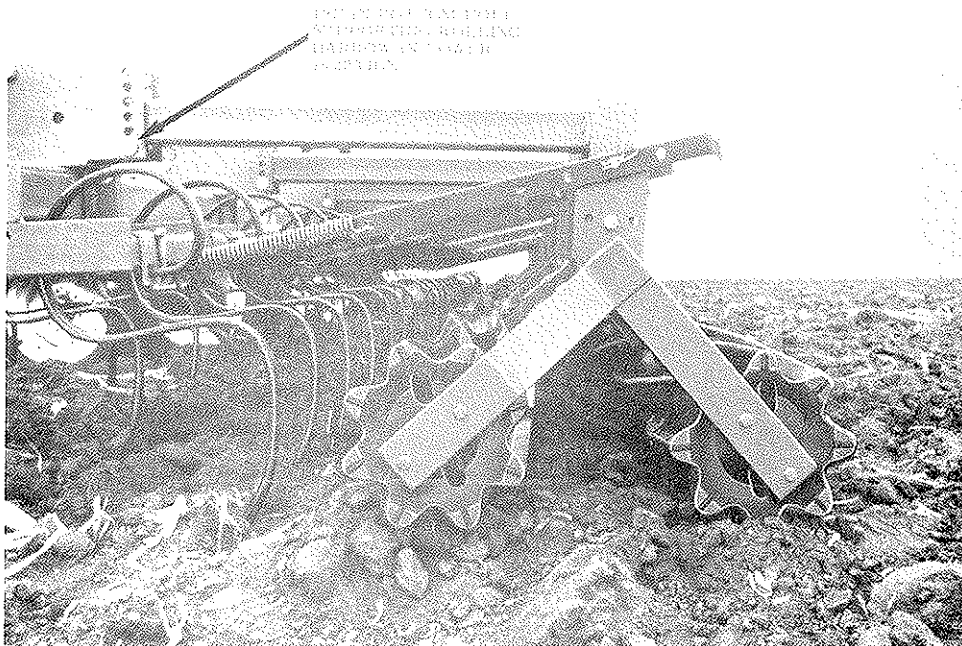

FIGURE 6

It is the responsibility of the owner/operator to comply with all applicable laws regarding slow moving vehicle signs, warning lights, and reflectors.

Working Speed

Best results are obtained by operating at a speed of 5 to 8 mph, especially if rolling harrows are used. Somewhat higher rates are also acceptable, but in no event should speed exceed the point at which the operator can safely control tractor and implement.

Leveling Board Adjustments

When leveling boards are used, the entire assemblies should be adjusted vertically so they level high spots only rather than drag heavily. Upper spring brackets can be adjusted as desired to provide a nearly vertical or more inclined angle with respect to the ground.

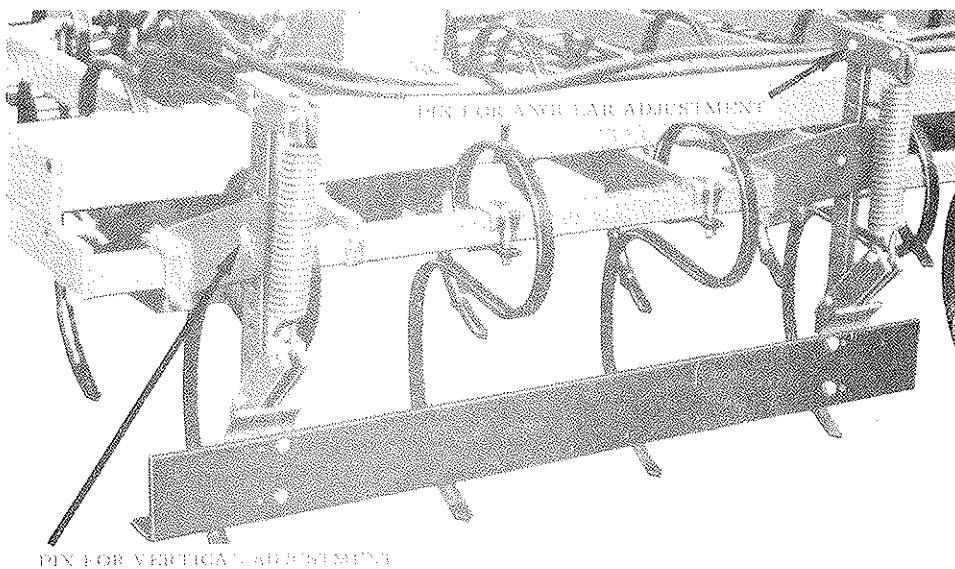

FIGURE 7

Chemical Incorporation

The primary requirement for successful incorporation is following the chemical manufacturer's instructions. However, the following suggestions are generally recognized, and should be observed unless specific instructions say otherwise:

1. Two passes, with the second at an angle to the first, usually give the best mixing.
2. Second pass should not be deeper than the first or untreated soil will be brought to the top.
3. If only one pass is made, shovels or sweeps will do a better job than points.
4. Machine should be level; rear tines must not be set deeper than those at front.
5. Good mixing can not be obtained in wet soil.
6. Relatively high speeds (6-8 mph) provide the best mixing.

Spray nozzles may be mounted on the cultivator-incorporator, but tanks should not, since the machine has not been designed to handle the extra weight.

Rolling Harrow Adjustments

Four types of adjustments are provided: (1) Forward-rearward of entire assemblies, (2) upward-downward of entire assemblies, (3) angular (changes height of front harrow reel with respect to rear reel), and (4) spring tension. While exact settings with need to be determined by trial, the following is intended as a general guide:

1. Harrows can be moved far enough rearward so the last rank of S-tines does not strike the reels. However, operating harrows closer to tines may provide a more level seed bed. Use upper hole if depth control pin does not permit reels to go deeply enough.
2. Entire assemblies can be held out of the ground. This may be desirable if the machine is being used to work a wet field at a shallow depth for drying. Caution! Do not fold wings with the two outer harrow assemblies on the center frame in the high position. See instructions under "Transport".

By inserting depth control pins as high as possible with harrows still penetrating the ground, the harrows can be lifted out of the ground without raising the machine fully when truning. This will reduce side loading and resultant stress on harrows and mounting brackets.

Disconnecting spring handles to release spring tension or lowering machine with a block under each rolling harrow reel can make this adjustment easier.

3. Angular adjustment for shallow working depth, especially with the 22" S-tines, can have both reels at the same height. Better tine track removal is also obtained with level reels. If the front reel tends to "block", it should be set slightly higher than the rear.
4. Spring tension prevents excessive bouncing. Extreme tension is usually not necessary.

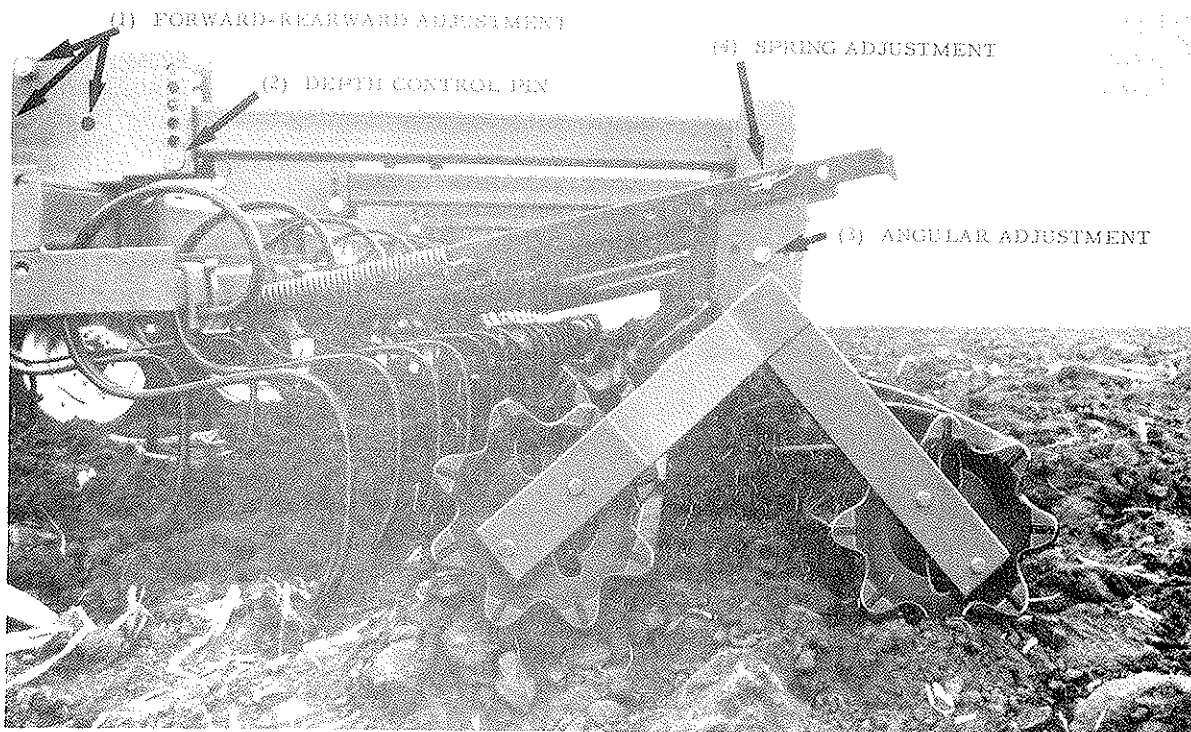

FIGURE 8

MAINTENANCE

Fasteners

After a few hours' use, check entire machine and tighten any loose nuts or bolts. Daily or preiodic checks should be made thereafter.

Tires

Recommended tire inflation pressure is as follows:

7.60 x 15	8 Ply Rating - - - -	52 psi
9.5L x 15	6 Ply Rating - - - -	28 psi
12.5L x 15	12 Ply Rating - - - -	56 psi

Lubrication

Grease zerck fittings daily. Locations are:

Joint between wheel arms and frame - - - - -	4
Wing hinges - - - - -	4
Wing lift links (both ends of link to which cylinder is attached) - -	4

The above items are not sealed and cannot be overgreased.

Rolling harrows should also be greased daily. The best time is after the machine is done running, to prevent condensation in the bearings. Give each bearing about two "shots" or grease until seal just starts to lift.

Wheel bearings and walking beam pivots should be repacked annually.

When machine is not used for some time, exposed portions of cylinder rods should be cleaned and covered with a thick coat of grease. This will prevent corrosion which will damage seals.

SHIPPING BUNDLES

Cultivator-Incorporators are shipped in separate assemblies according to the following lists:

C & CS Models (with 22" x 10 mm x 32 mm tines)

	C-2381	C-2641	C-2981	C-3241	CS-2381	CS-2641	CS-2981	CS-3241
4J-853	1	1	1	1	1	1	1	1
4J-854	1	1	-	-	1	1	-	-
4J-855	1	1	-	-	1	1	-	-
5J-620	-	-	1	1	-	-	1	1
5J-621	-	-	1	1	-	-	1	1
4J-866	-	2	-	-	-	2	-	-
4J-858	1	1	1	1	1	1	1	1
4J-859	2	2	2	2	2	2	2	2
4J-860	1	1	1	1	-	-	-	-
4J-861	1	1	1	1	-	-	-	-
4J-862	-	-	-	-	1	1	1	1
4J-863	-	-	-	-	1	1	1	1
4J-864	-	-	-	-	1	1	1	1
4J-865	-	-	-	-	1	1	1	1
4J-867	1	1	1	1	1	1	1	1
4J-868	2	2	2	2	2	2	2	2
4J-869	2	2	2	2	2	2	2	2
4J-870	2	2	2	2	2	2	2	2
4J-871	2	2	2	2	2	2	2	2
4J-872	4	4	4	4	4	4	4	4
2J-419	1	1	1	1	1	1	1	1
4J-874	1	1	-	-	1	1	-	-
4J-875	-	-	1	1	-	-	1	1
4J-876	1	1	1	1	1	1	1	1
4J-877	1	1	1	1	1	1	1	1
5J-610	1	1	1	1	1	1	1	1
4J-879	-	1	1	2	-	1	1	1
1J-887	71	79	89	97	71	79	89	97
2J-230	-	-	2	2	-	-	2	2
2J-231	-	1	-	-	-	1	-	-
2J-232	2	-	-	-	2	-	-	-
2J-332	-	1	-	-	-	1	-	-
2J-336	-	-	-	-	-	-	-	-
3J-635	1	-	-	1	-	-	-	1
3J-814	-	-	-	-	-	-	-	-
6J-996	1	1	1	1	-	-	1	-
6J-997	1	1	1	1	-	-	-	-

SHIPPING BUNDLES

Cultivator-Incorporators are shipped in separate assemblies according to the following lists:

C & CS Models (with 22" x 10 mm x 32 mm tines) Continued

	C-2381	C-2641	C-2981	C-3241	CS-2381	CS-2641	CS-2981	CS-3241
7J-45	-	-	2	-	-	-	-	-
4J-657	2	2	2	2	2	2	2	2
4J-658	1	1	1	1	1	1	1	1
4J-659	1	1	1	1	1	1	1	1
4J-660	1	1	1	1	1	1	1	1
4J-661	1	1	1	1	1	1	1	1
6D-311	8	8	8	8	-	-	-	-
6D-312	-	-	-	-	2	2	2	2
4J-699	-	-	-	-	2	2	2	2
2J-858	1	1	1	1	1	1	1	1
5J-585	-	-	-	2	-	-	2	2
5J-611	-	-	2	2	-	-	2	2
5J-613	-	-	-	2	-	-	-	2
5J-614	-	-	-	2	-	-	-	2

Points or shovels are ordered separately.

CH & CSH Models (with 26" x 12 mm x 32 mm tines)

	CH-2381	CH-2641	CH-2981	CH-3241	CSH-2381	CSH-2641	CSH-2981	CSH-3241
4J-853	1	1	1	1	1	1	1	1
4J-854	1	1	-	-	1	1	-	-
4J-855	1	1	-	-	1	1	-	-
5J-620	-	-	1	1	-	-	1	1
5J-621	-	-	1	1	-	-	1	1
4J-866	-	2	-	-	-	2	-	-
4J-858	1	1	1	1	1	1	1	1
4J-859	2	2	2	2	2	2	2	2
4J-860	1	1	1	1	-	-	-	-
4J-861	1	1	1	1	-	-	-	-
4J-862	-	-	-	-	1	1	1	1
4J-863	-	-	-	-	1	1	1	1
4J-864	-	-	-	-	1	1	1	1
4J-865	-	-	-	-	1	1	1	1

SHIPPING BUNDLES

Cultivator-Incorporators are shipped in separate assemblies according to the following lists:

CH & CSH Models (with 26" x 12 mm x 32 mm tines) Continued

	CH-2381	CH-2641	CH-2981	CH-3241	CSH-2381	CSH-2641	CSH-2981	CSH-3241
4J-867	1	1	1	1	1	1	1	1
4J-868	2	2	2	2	2	2	2	2
4J-869	2	2	2	2	2	2	2	2
4J-870	2	2	2	2	2	2	2	2
4J-871	2	2	2	2	2	2	2	2
4J-872	4	4	4	4	4	4	4	4
2J-419	1	1	1	1	1	1	1	1
4J-874	1	1	1	1	1	1	1	1
4J-875	-	-	-	-	-	-	-	-
4J-876	1	1	1	1	1	1	1	1
4J-877	1	1	1	1	1	1	1	1
5J-610	1	1	1	1	1	1	1	1
4J-879	-	-	-	-	-	-	-	-
4J-700	71	79	89	97	71	79	89	97
4J-880	2	1	1	1	2	1	1	1
4J-881	-	1	-	-	-	1	-	-
4J-882	-	1	2	-	-	1	-	-
4J-883	1	-	-	-	-	-	-	-
4J-657	1	1	-	-	1	1	-	-
4J-658	2	2	2	2	2	2	2	2
4J-659	1	1	1	1	1	1	1	1
4J-660	1	1	1	1	1	1	1	1
4J-661	1	1	1	1	1	1	1	1
6D-311	1	1	1	1	1	1	1	1
6D-312	8	8	8	8	8	8	8	8
4J-699	-	-	-	-	-	-	-	-
2J-858	1	1	1	1	1	1	1	1
5J-585	-	-	-	-	-	-	-	-
5J-611	-	-	2	2	-	-	2	2
5J-613	-	-	-	2	-	-	-	-
5J-614	-	-	-	2	-	-	-	-
6J-996	1	1	1	1	1	1	1	1
6J-997	1	1	1	1	1	1	1	1
7J-45	-	-	2	-	-	-	-	-

Points or shovels are ordered separately.

Rolling Harrows

		RH-238	RH-264	RH-298	RH-324
4J-902	Bracket	4	4	5	5
4J-903	Bracket	4	4	5	5
4J-904	Extension	8	8	10	10
4J-905	Long Harrow Asy.	6	8	8	10
4J-906	Short Harrow Asy.	2	-	2	-
4J-907	Box Asy. For 8 Harrows	1	1	-	-
4J-910	Box Asy. For 8 Harrows	1	1	1	1
4J-911	Box Asy. For 8 Harrows	1	1	1	1
4J-908	Box Asy. For 10 Harrows	-	-	1	1
4J-909	Box Asy. For 2 Harrows	-	-	1	1

		4J-889 Wheel Track (all machines)	4J-890 Full Length (23'8") machine)	4J-891 Full Length (26'4") machine)	4J-892 Full Length (29'8") machine)	4J-893 Full Length (32'4") machine)
4J-894	Leveler Box Asy.	4	5	7	7	7
4J-895	Long Leveler Angle (54½")	-	5	3	5	7
4J-896	Short Leveler Angle (36")	4	-	4	2	-
* 7J-51	Bracket Assembly	1 (29'8" Mach. Only)	-	-	1	-

* Required for 29'8" models with walking beam axles only.

SETTING UP INSTRUCTIONS

1. Support 6" x 4" tubes of center frame on four stands at least 23" high. Be sure supports are stable and of adequate strength to carry machine weight.
2. Attach right and left wheel arms (or walking beam assemblies on machines so equipped) and wheels to center frame using 1-1/2" x 14-5/8" pins and 3/8" x 3" roll pins. Single wheel (or walking beam) is on "outside" of wheel arm. Tires used on center frame are either two 12.5L x 15 12 ply or four 7.60 x 15 8 ply.

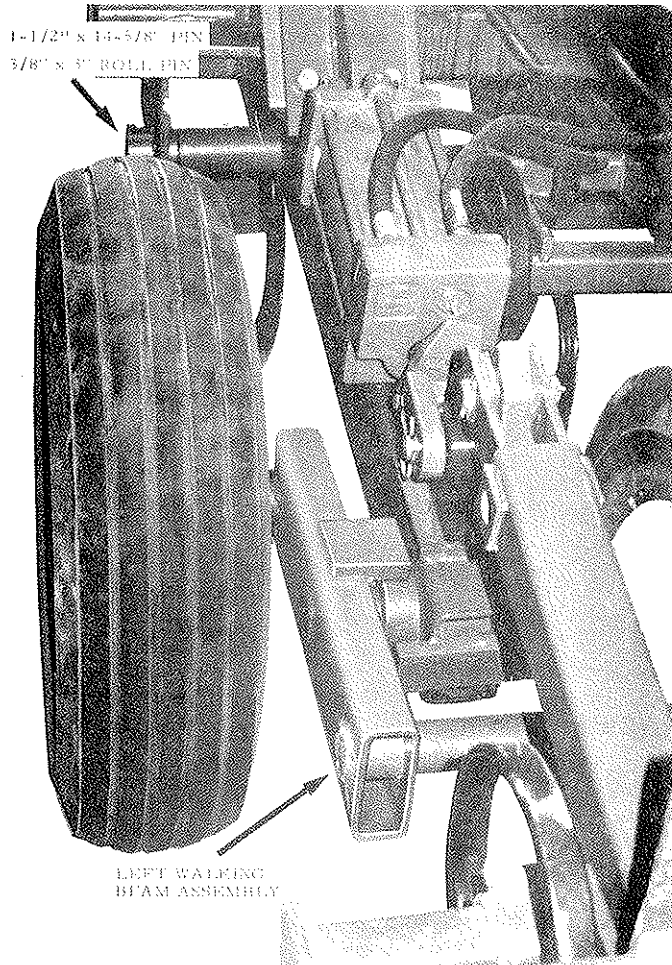

FIGURE 9

3. Install cylinder lugs and depth control cylinders on center frame. Lugs go in upper position for standard tines (22" x 10 mm x 32 mm) and lower position for heavy tines (26" x 12 mm x 32 mm). Use 5/8" x 2" cap screws, nuts and lockwashers. See Figure 10

Use 5" master cylinder on left and 4-1/2" slave cylinder on right. See hydraulic diagram on page 22.

Shims are provided for use under cylinder lugs if necessary. They should not be installed at this time. Their use is explained under "Side-To-Side Leveling" on page 7.

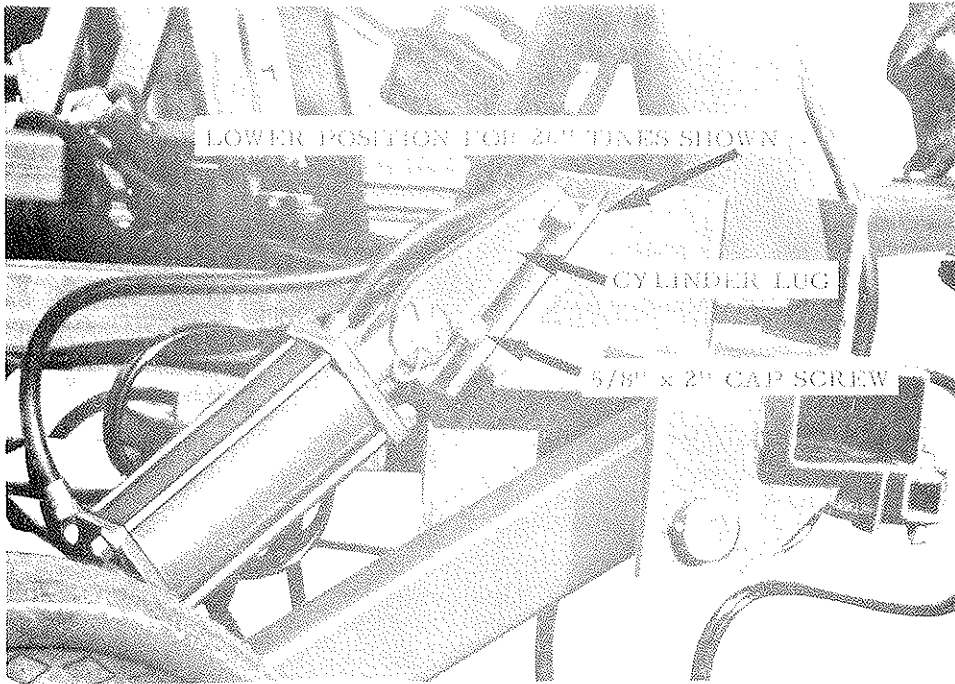

FIGURE 10

4. Install transport lock tubes and links. Use 1" x 6-1/4" pins between tube and frame, and 1" x 3" pins between link and wheel arm. One inch by 5" pin is used to lock tube and link together for transport.

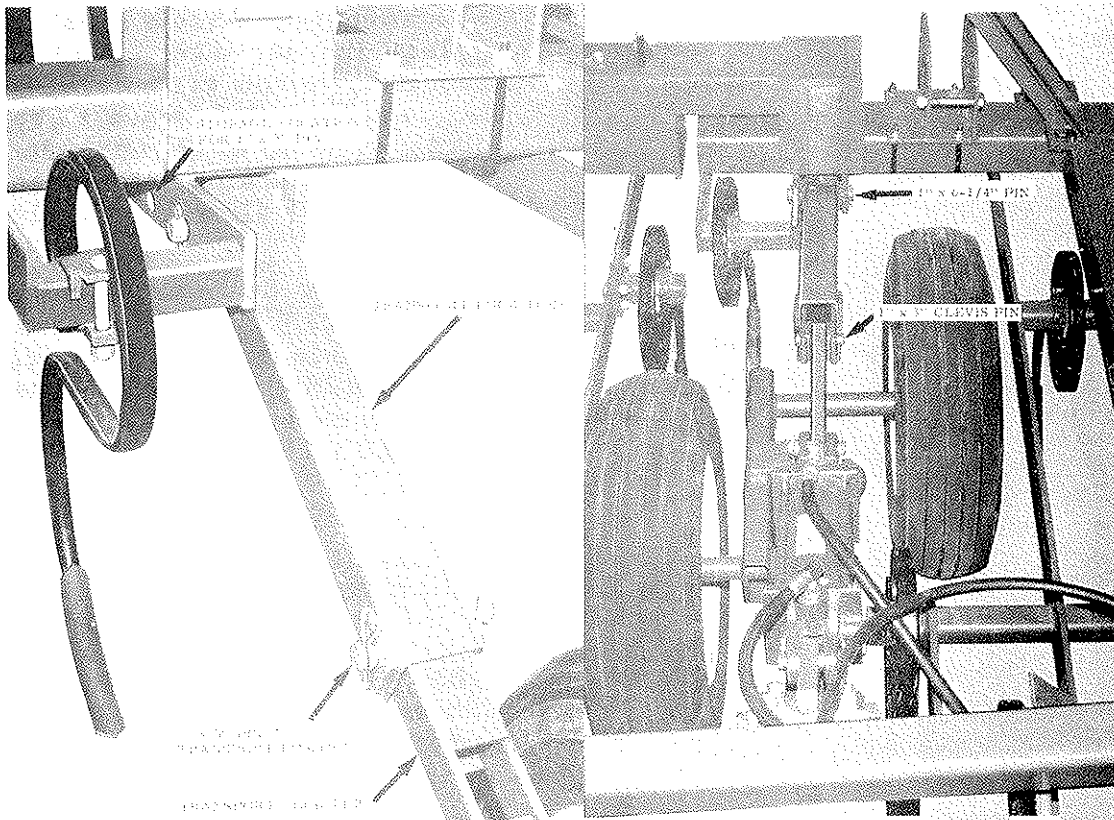

FIGURE 11

5. Attach wings to center frame with 1-1/4" hinge pins with welded tabs. Use 3/8" x 1-3/4" cap screws with self locking nuts to secure pins.

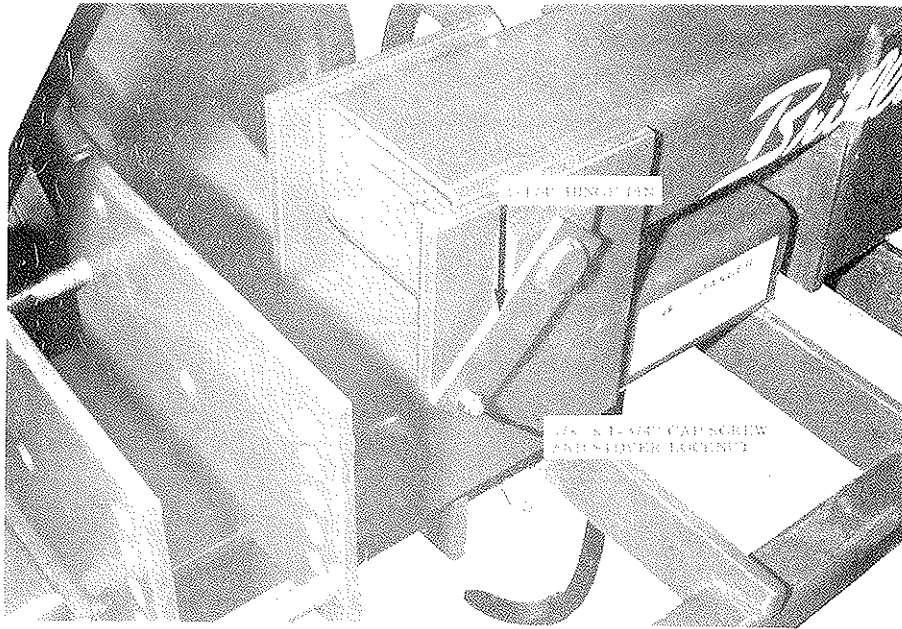
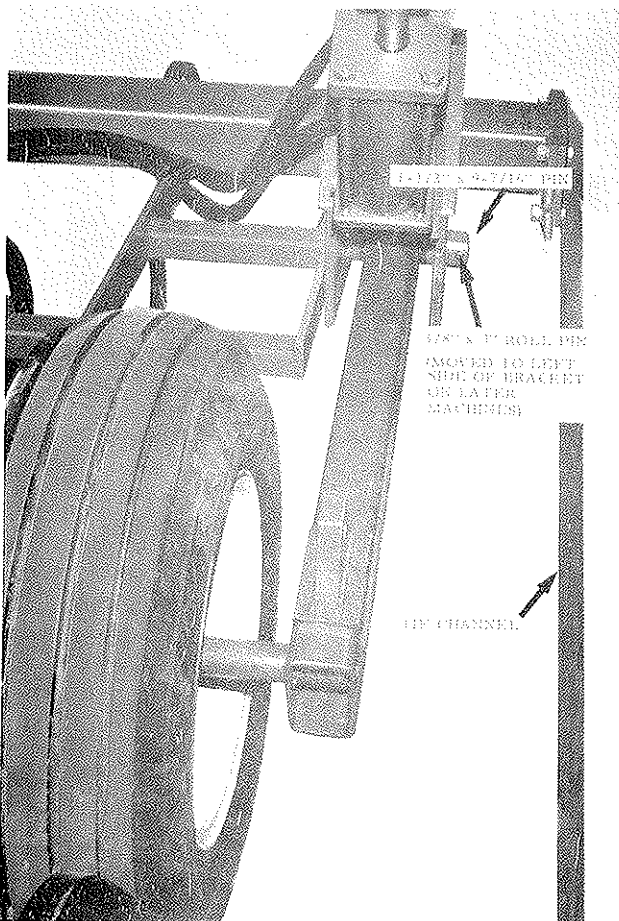

FIGURE 12

6. Attach wing wheel arms (or walking beam assemblies) using 1-1/2" x 9-7/16" pins and 3/8" x 3" roll pins.

For single axles only: Left and right wheel arms may be interchanged to locate wheels either inward or outward on all except 29'8" machine

which requires wheels inward. Unless the narrower tread is required for row crop work, it is recommended wheels be placed outward to help prevent tires from sinking into loose soil. Use 9.5L x 15 six ply tires.



For walking beam axles only: Machines 23'8" and 26'4" have rear wheels toward outside. Machines 29'8" and 32'4" have rear wheels toward inside. Use 7:60 x 15 six ply tires.

FIGURE 13
RIGHT WING WHEEL ARM
(Shown on right wing of 29'8" machine)

7. Install cylinder lugs and depth control cylinders for wings similar to center frame. Smaller cylinder is used on right wing. Cap screws are 5/8" x 2-1/4" to allow for shims.
8. On 26'4" machine; Bolt on single piece wing extensions using 5/8" x 2" cap screws, lockwashers, and stover lock nuts.
 On 29'8" machine; Bolt on tie channels (with single axles) or wing extensions (with walking beams) using 5/8" x 2" cap screws, lockwashers, and stover lock nuts.
 On 32'4" machine; Bolt on front wing extensions (18-1/2" long) and rear wing extensions (20-1/2" long). Tie channels fasten to outside of wing extensions. Use 5/8" x 2" cap screws, lockwashers, and stover lock nuts.
9. Drawbar attaches to center frame with 5/8" x 2" cap screws, nuts, and lockwashers. Drawbar braces use 5/8" x 1-3/4" cap screws and 3/4" x 2" cap screws with nuts and lockwashers. Drawbar link connects drawbar to center frame with four 3/4" x 2-1/4" cap screws, lockwashers and stover lock nuts. If machine is to be assembled with 6" tine spacing, a tine should be attached to the drawbar link before the link is installed.

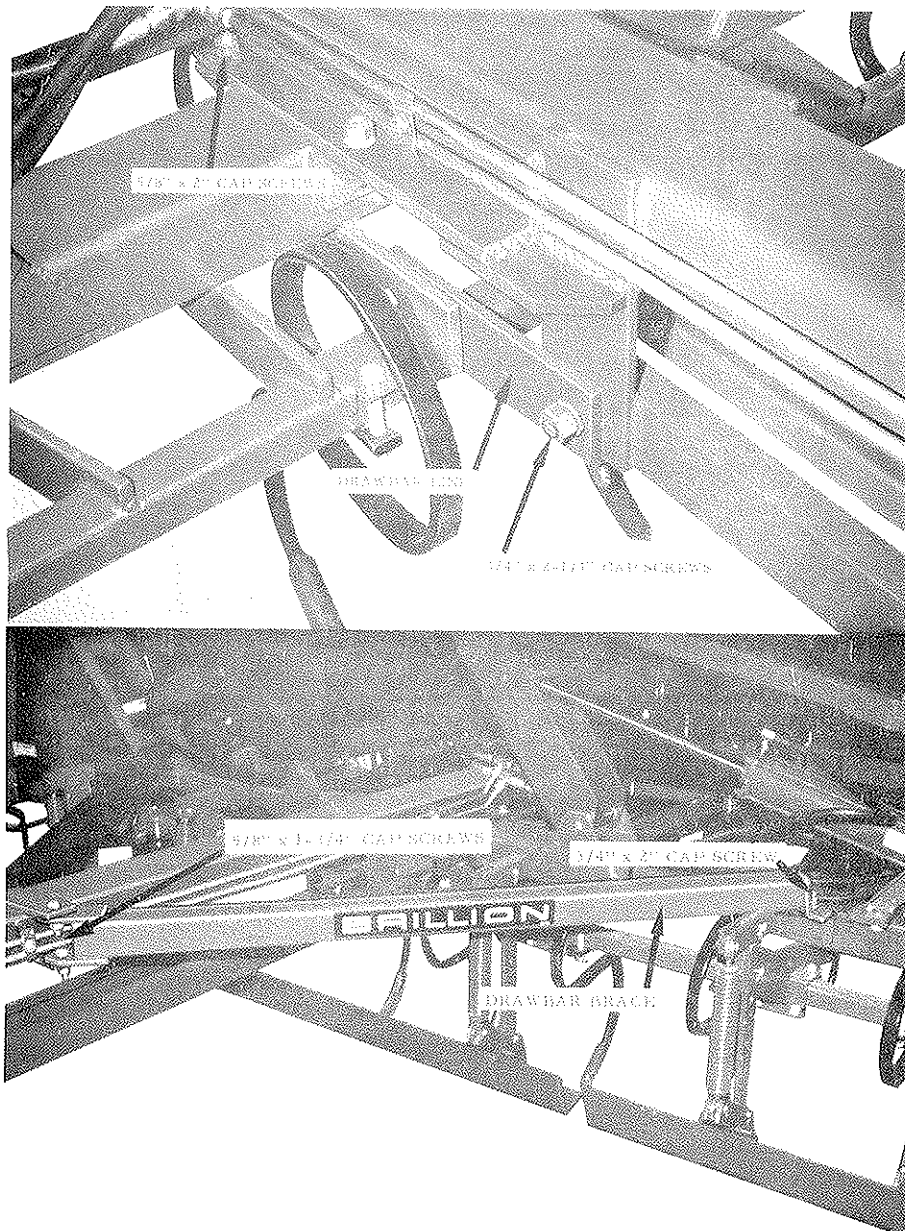

FIGURE 14

- Attach wing stands with $5/8"$ x $1-1/2"$ cap screws, nuts, and lock-washers.

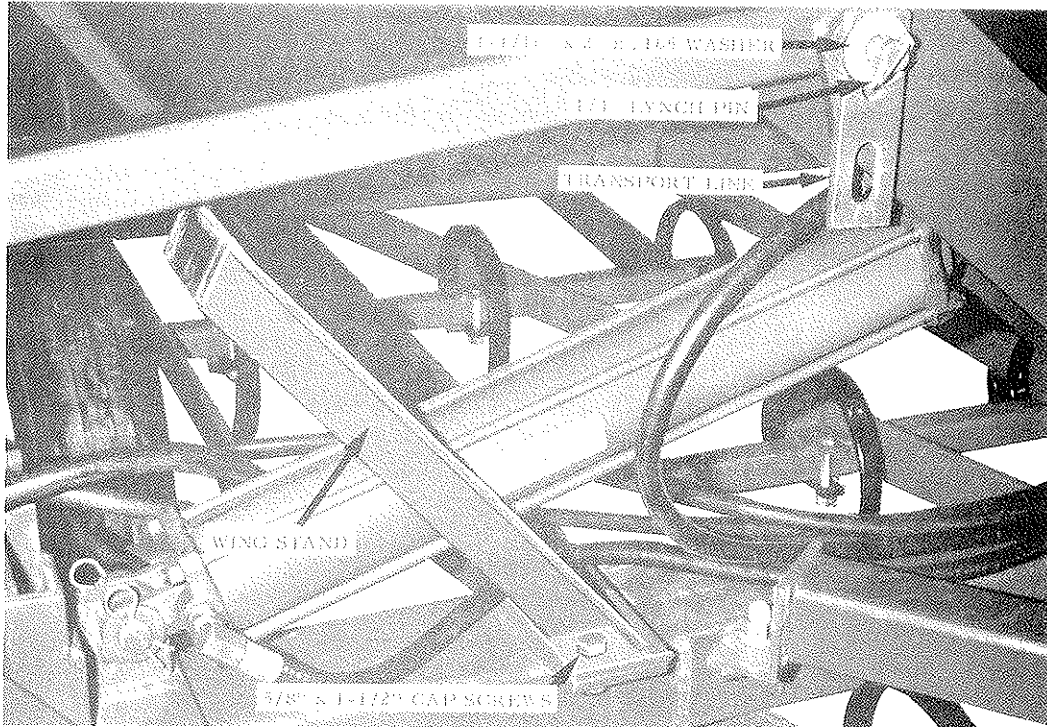

FIGURE 15

- Install wing lift linkages and cylinders.

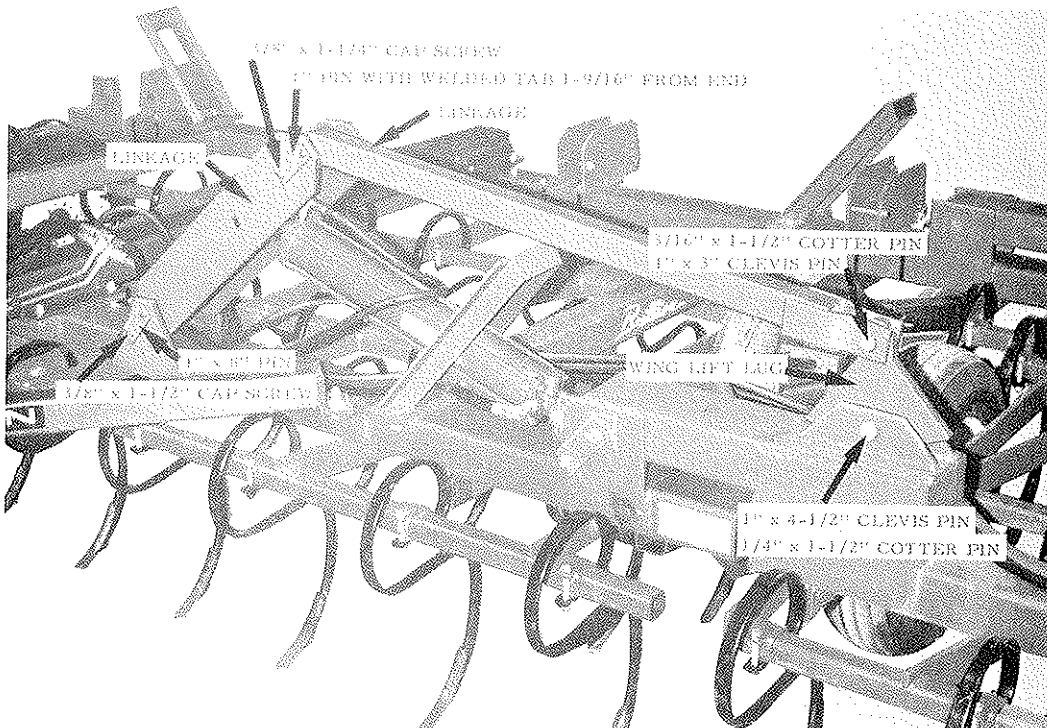

FIGURE 16

12. Install hydraulic lines according to hydraulic circuit diagram, page 22, securing hoses with plastic cable ties provided. Steel tubes are fastened with 1" x 2-1/2" x 1/8" formed clamps and 5/16" x 1" cap screws. Be sure that hoses near wing lift links clear links and wing stands when wings are raised.
13. Install grease zerks in areas indicated under "Lubrication".
14. Install tines according to spacing charts starting on page 23. If machine is assembled with 4" spacing, a bolt-on tooth tube is attached to each wing near the center frame wheels. Use 1/2" x 1-3/4" cap screws with nuts and lockwashers.

Bolt-on tooth tubes are used behind outer walking beam wheels or in front of center frame wheel on single axle machines. Bolt-on tooth tubes are not used with 6" tine spacing.

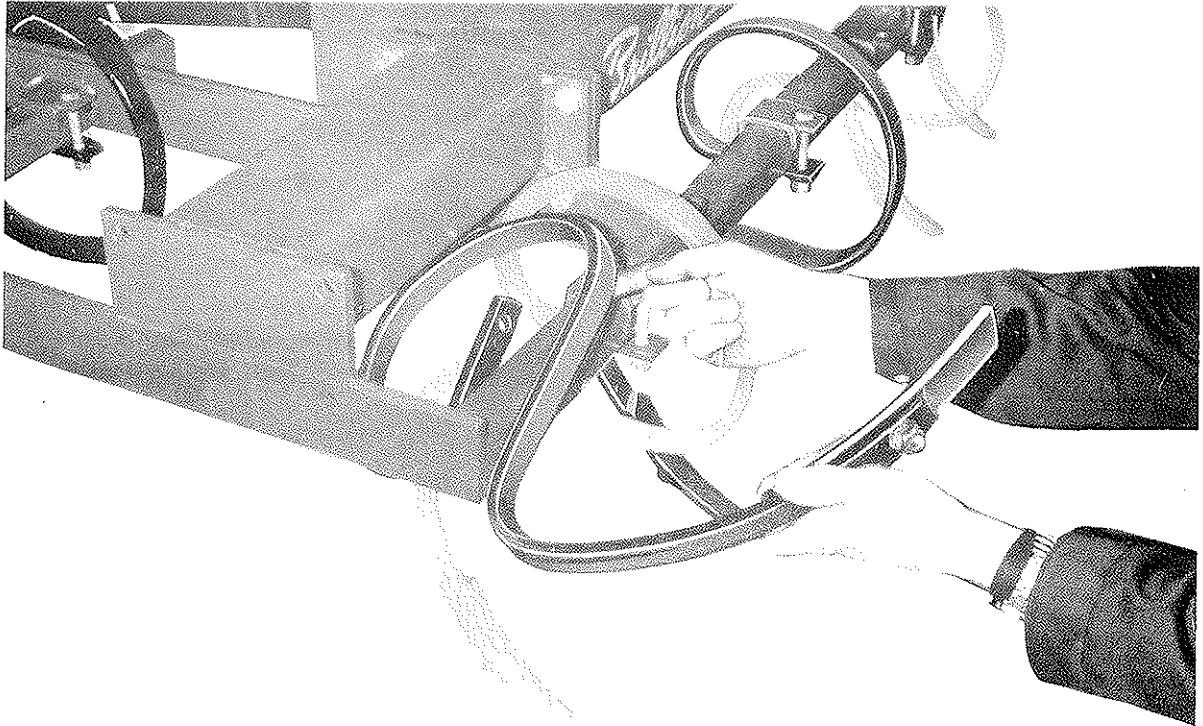

FIGURE 17

Clamps 1J-834 for standard tines are painted red and use 7/16" x 3-1/2" carriage bolts. Clamps 5J-80 for heavy duty tines are painted black and use 1/2" x 3-1/2" carriage bolts.

HYDRAULIC CIRCUIT DIAGRAM

Notes:

1. Where two hose lengths are shown, the shorter is for narrow wings.
2. Depth control cylinders must all be the same brand.

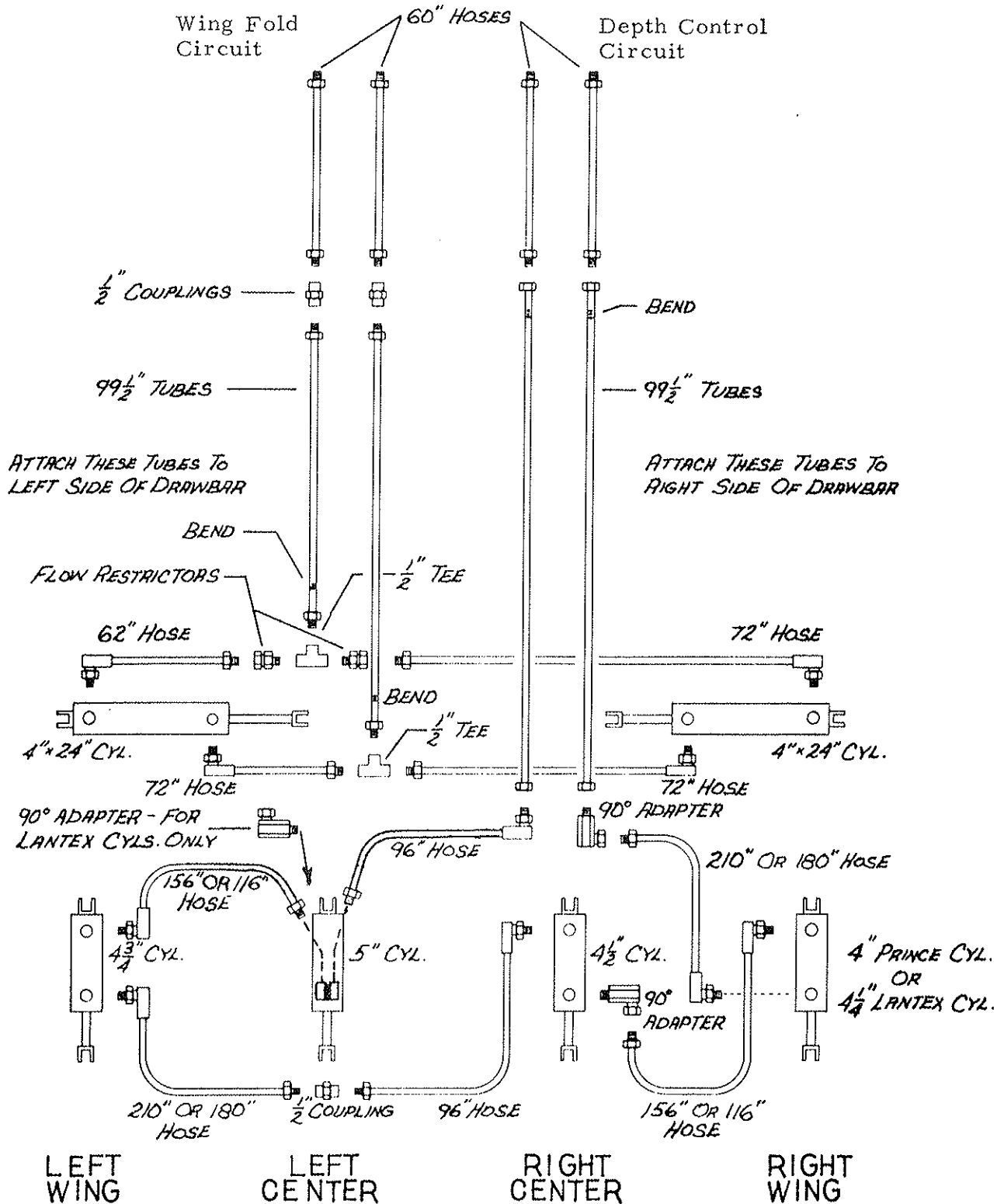

CENTER FRAME

4" SPACING

41 TINES

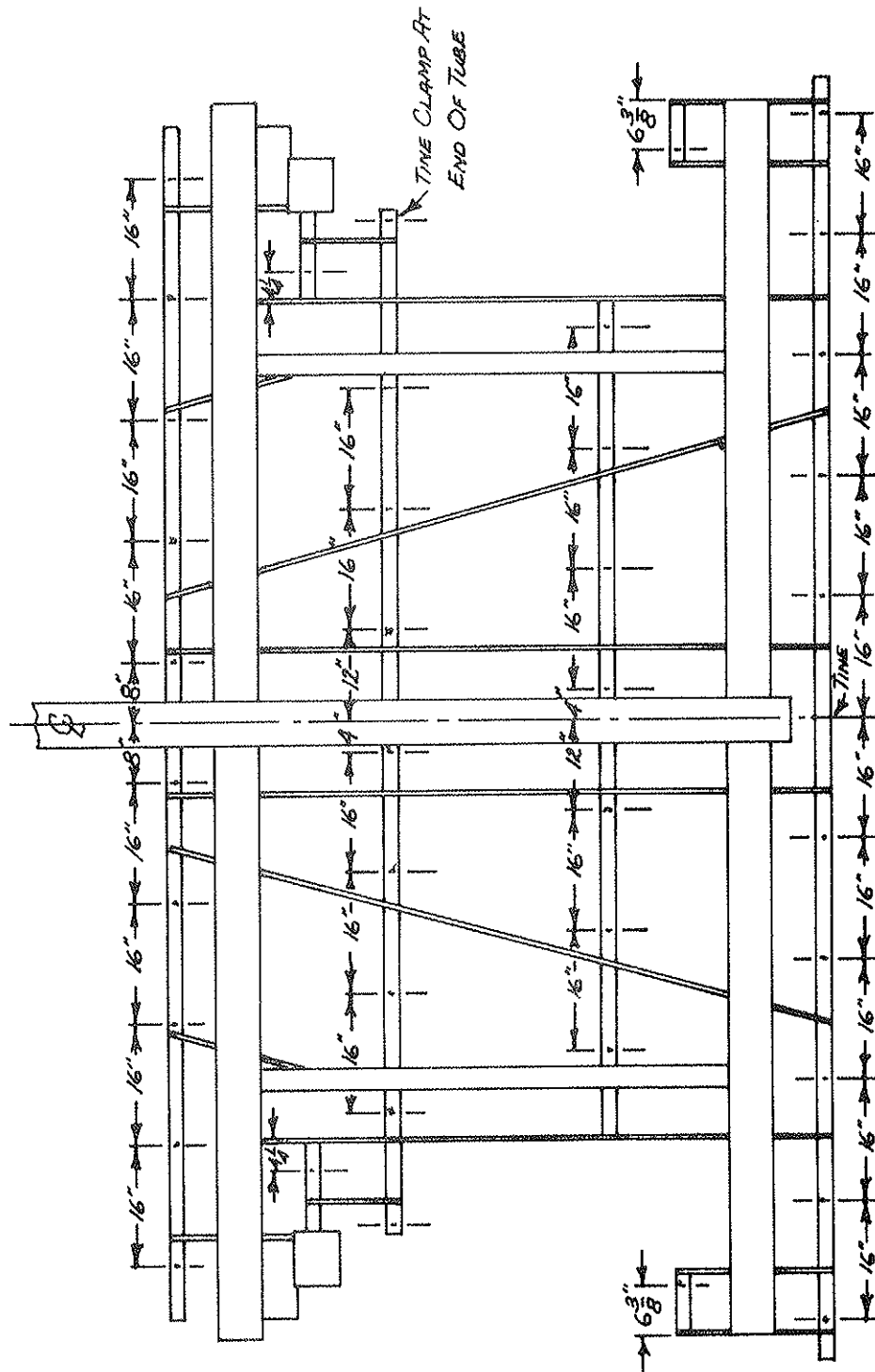

CENTER FRAME
 6" SPACING
 29 TINES

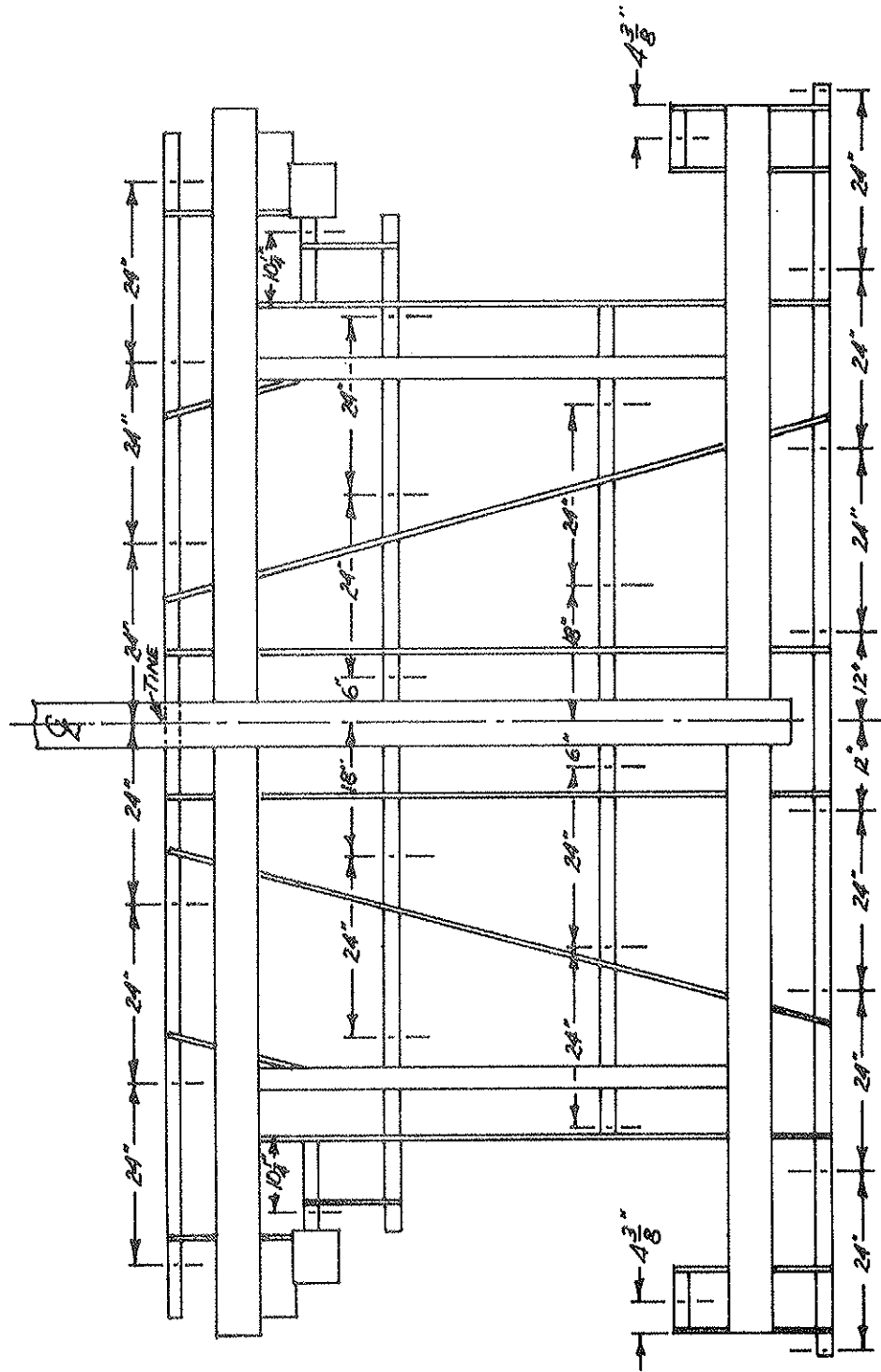

NARROW WINGS WITH SINGLE AXLES

4" SPACING

15 TINES PER WING

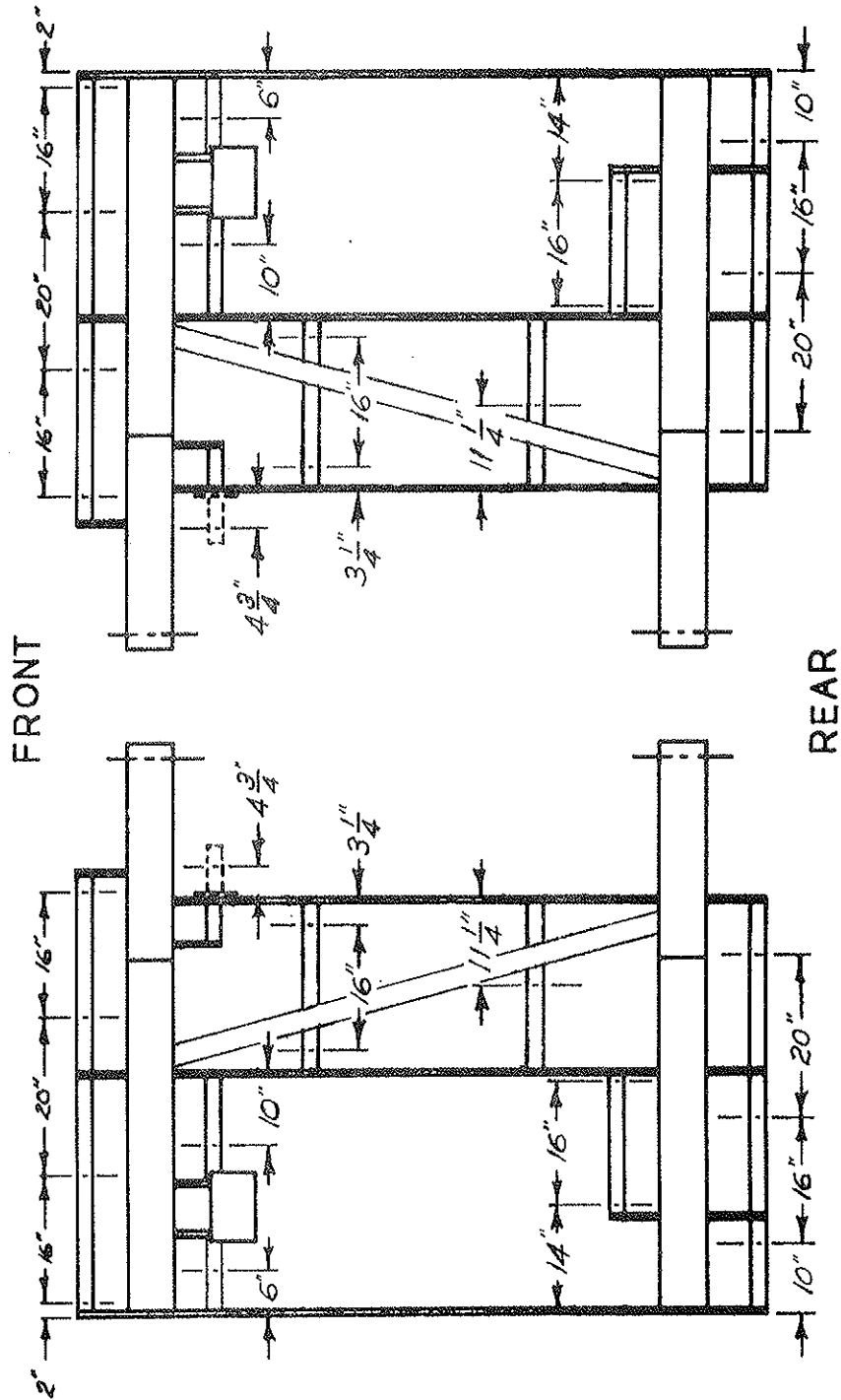

WING EXTENSIONS
WITH SINGLE AXLES OR WALKING BEAMS
TINE SPACING FOR NARROW WINGS

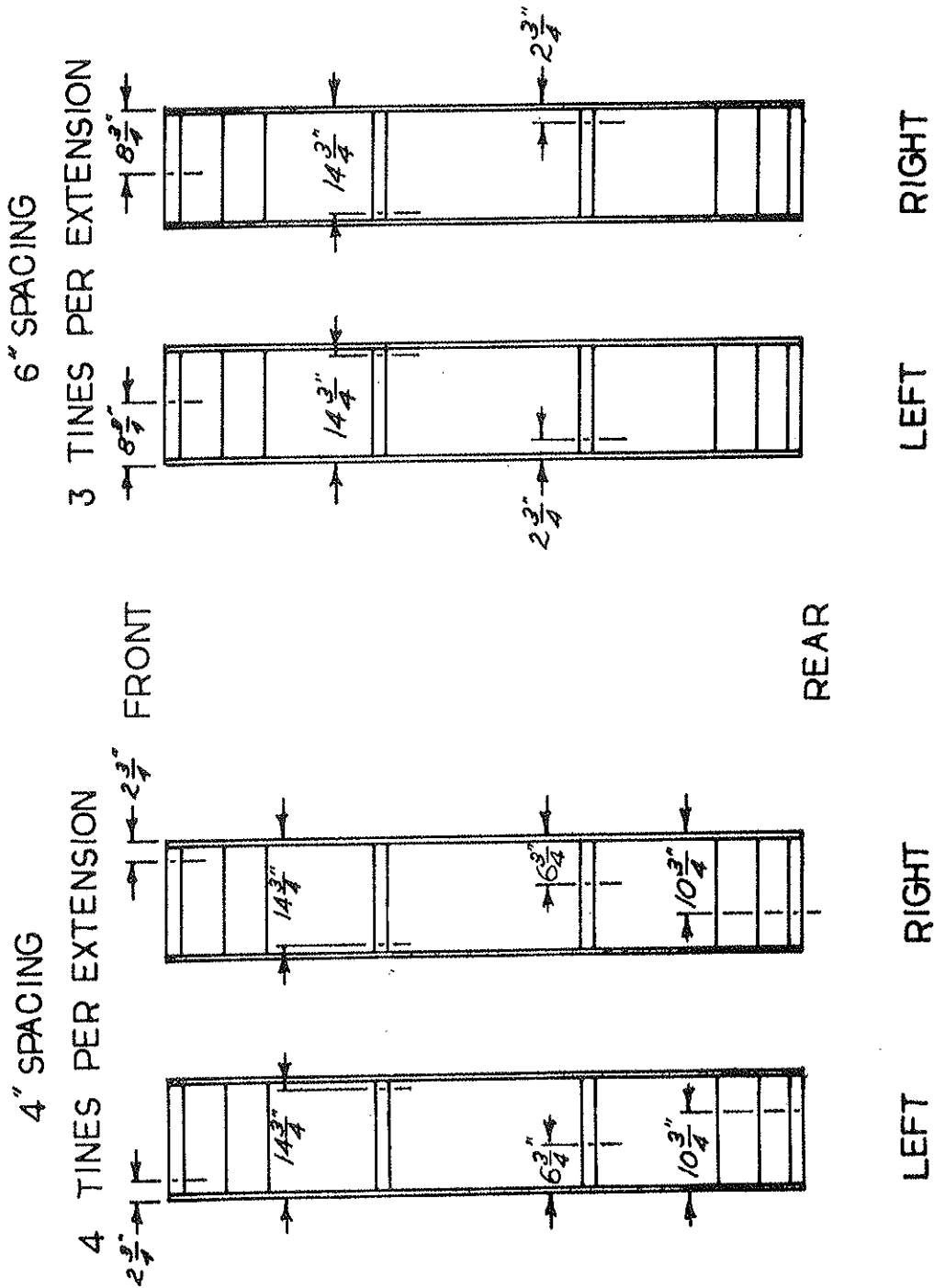

WIDE WINGS WITH WALKING BEAMS

6" SPACING

15 TINES PER WING

FOR: 29'8" MACHINE

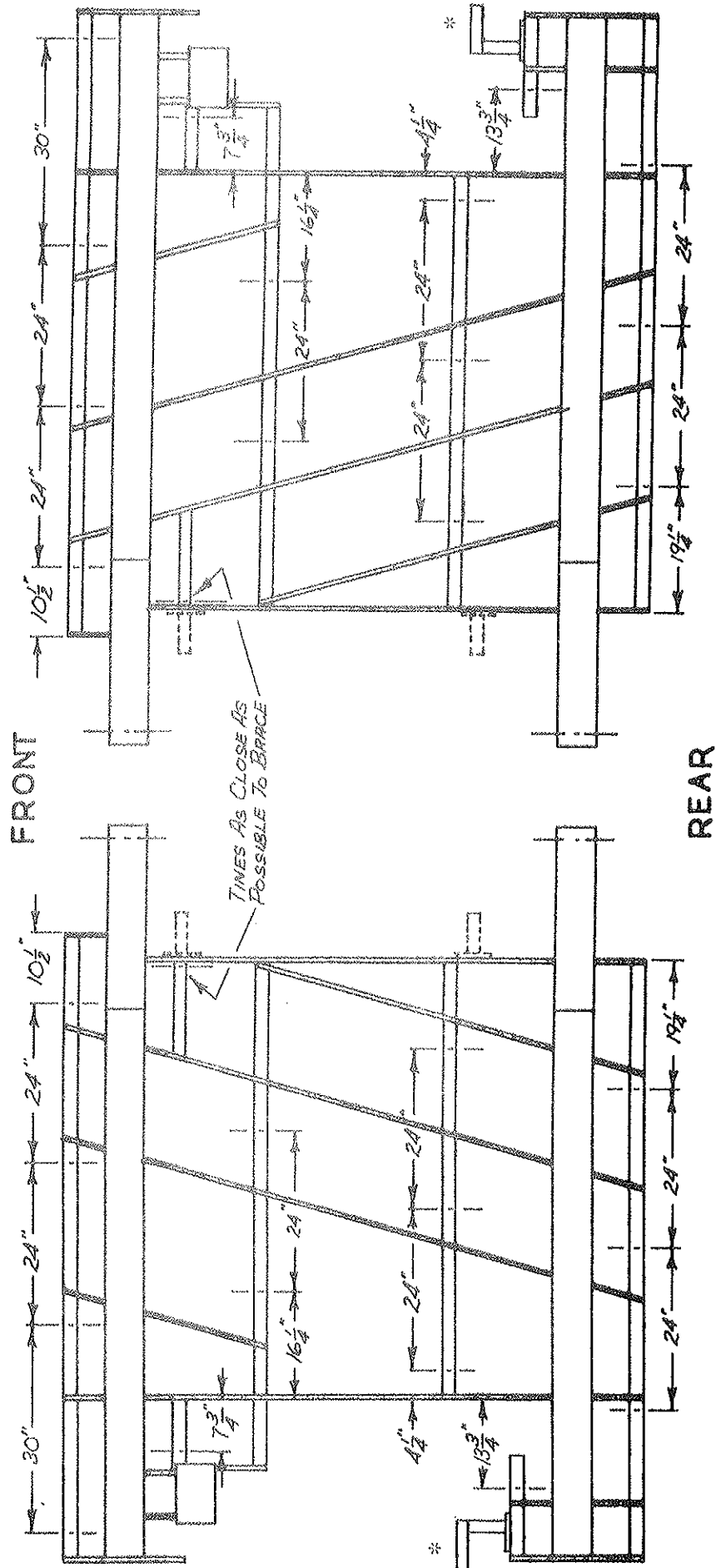

* Additional tines may be located on 5J-611 extension assemblies to remove wheel tracks.

WING EXTENSIONS TINE SPACING FOR WIDE WINGS

WALKING BEAMS
4" SPACING

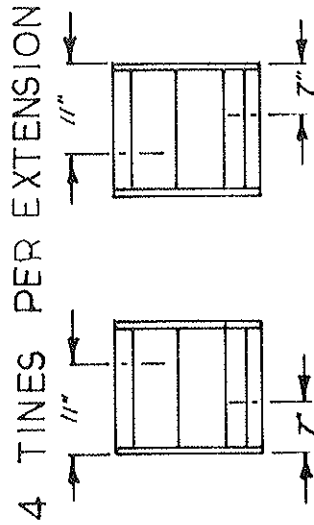

SINGLE AXLES
EITHER WHEEL POSITION
4" SPACING

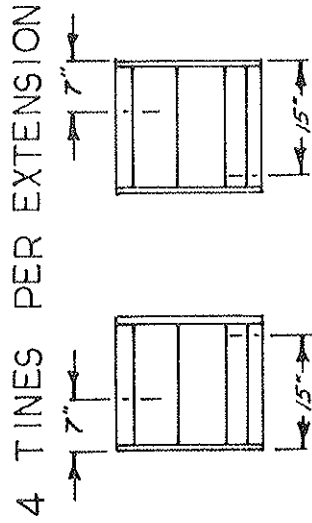

ALL AXLES AND
WHEEL POSITIONS
6" SPACING

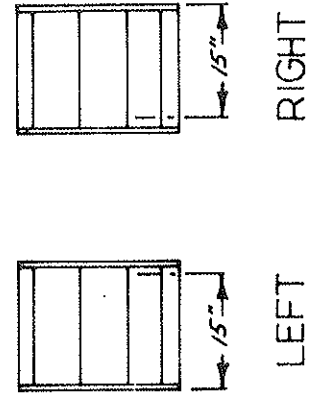
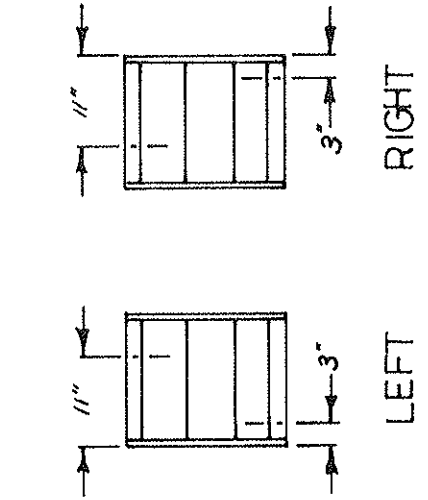
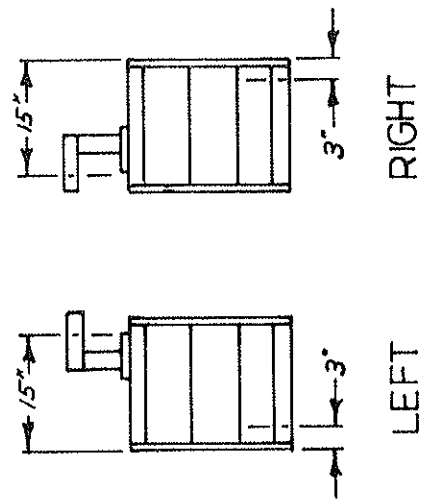
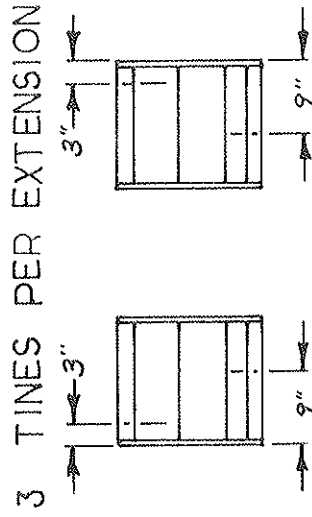

LEFT

RIGHT

LEFT

RIGHT

LEFT

RIGHT

REAR

Rolling Harrow Installation



Caution. Machine is drawbar light when rolling harrows are attached. All cylinders must be retracted (wings lowered and tines lowered to ground) when not hitched to a tractor. Use jack on rear of center frame. When attaching machine to tractor, slight extension of depth control cylinders will raise front tines off ground and allow hitch to be raised or lowered using jack at rear.

1. Install jack bracket at rear of center frame using L bolts, nuts, and lockwashers.

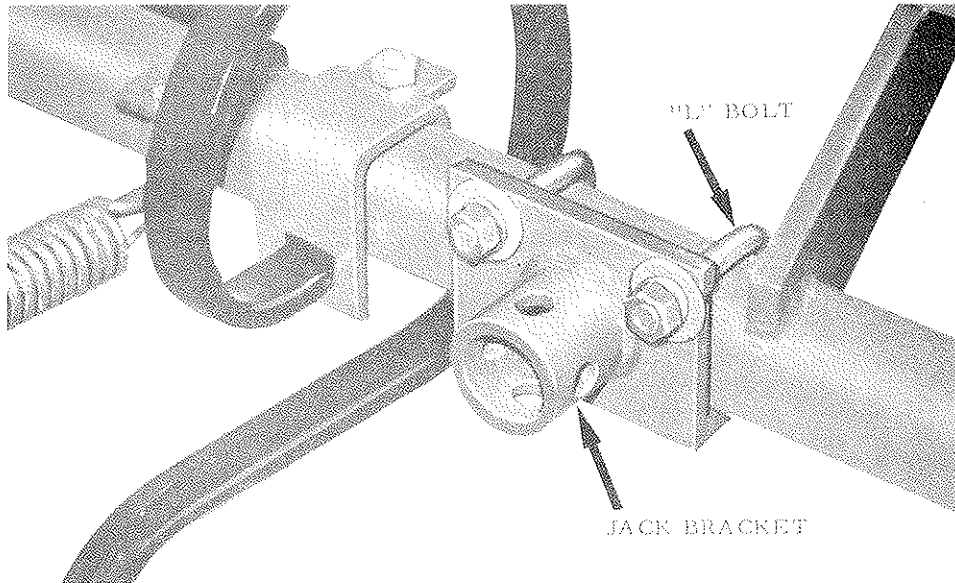

FIGURE 18

2. Secure mounting brackets to rear 6" x 4" frame tube with U-bolts, 5/8" nuts, and lockwashers. Refer to Rolling Harrow Installation charts on pages 32 and 33.

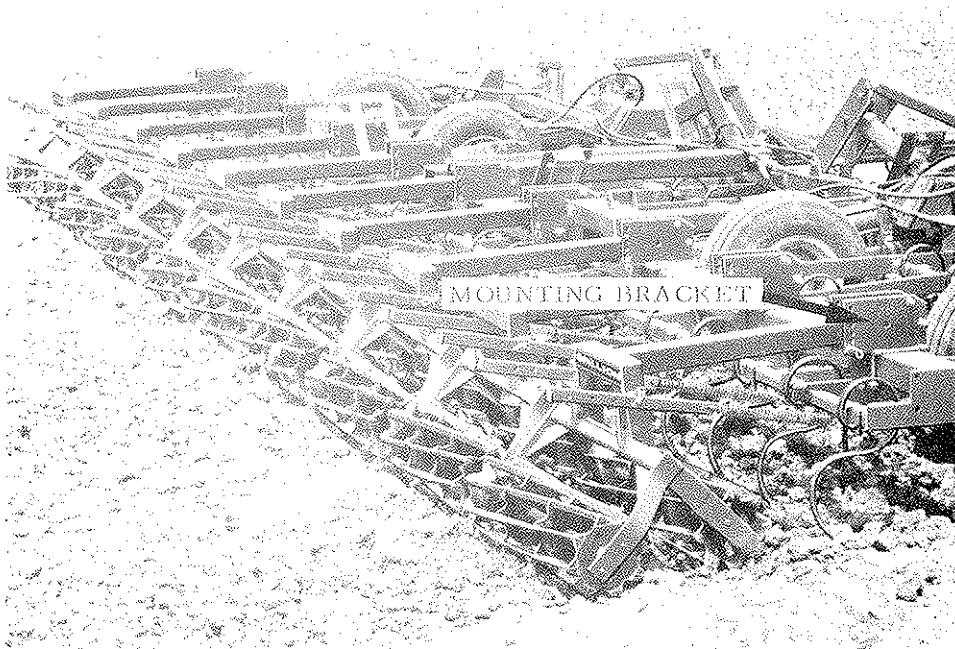
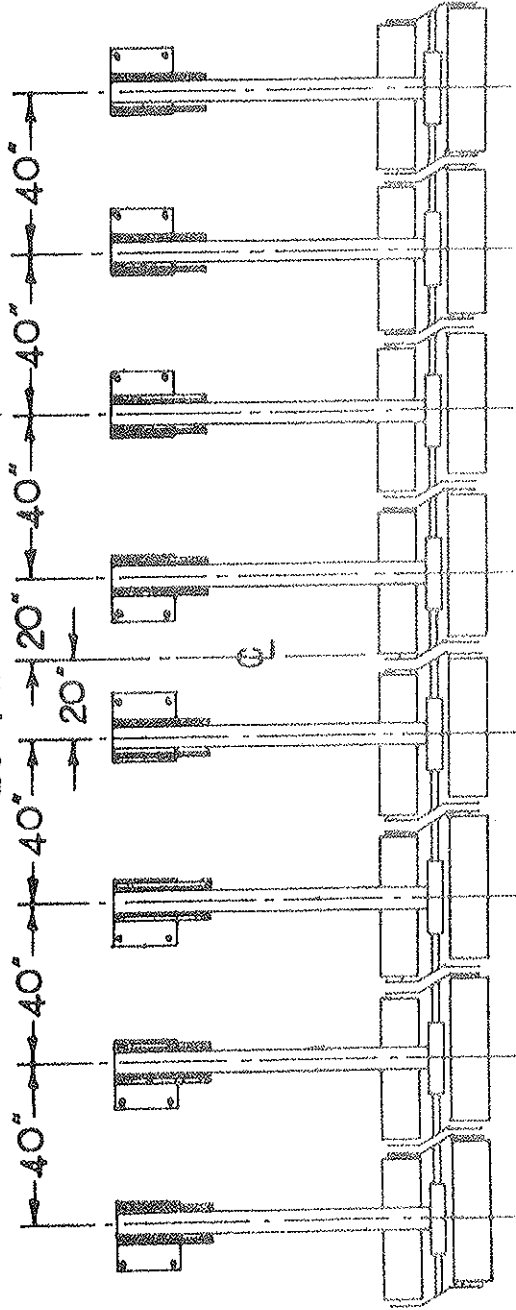

FIGURE 19

ROLLING HARROW INSTALLATION

26' 4" MACHINE



23' 8" MACHINE

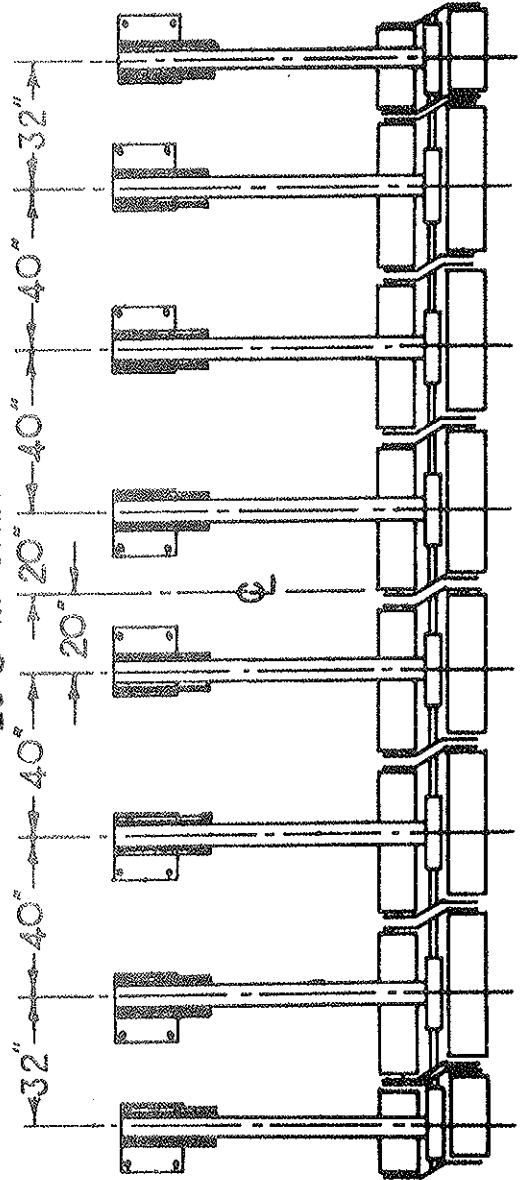

WIDE OVER-LAP ROLLING HARROW INSTALLATION

26' 4" MACHINE

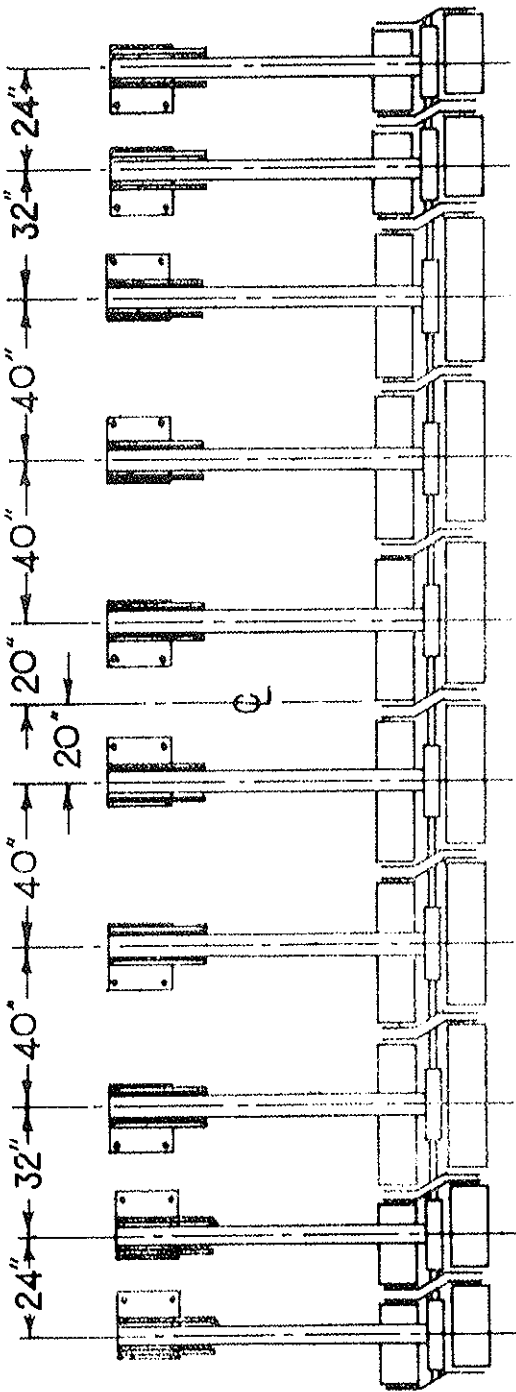

Provides 12 1/4
Overlap
On Each Side

23' 8" MACHINE

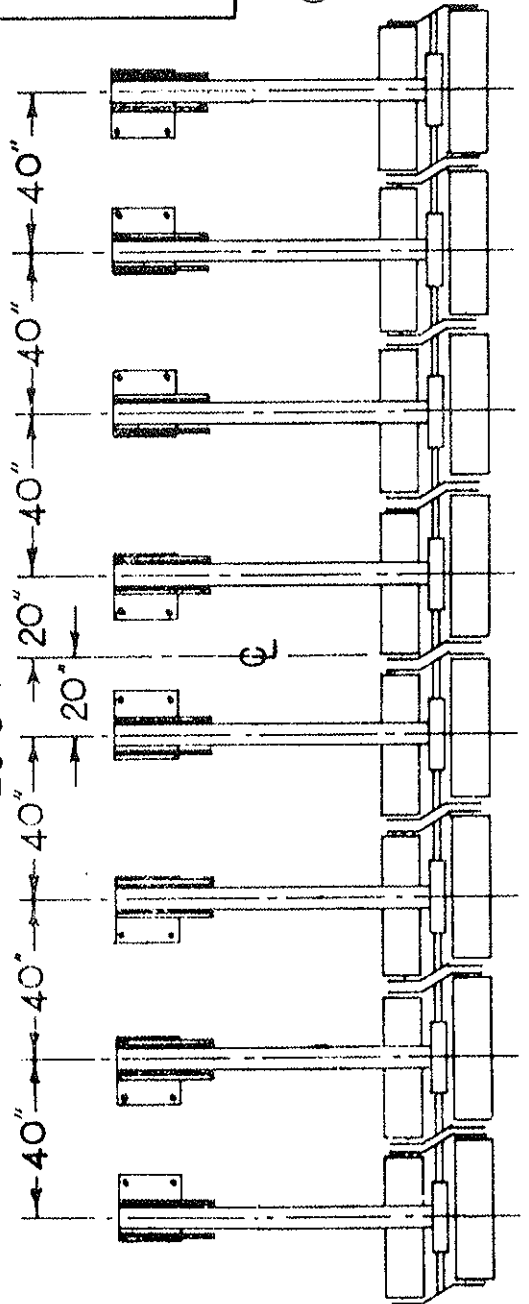

Provides 20 1/4
Overlap
On Each Side

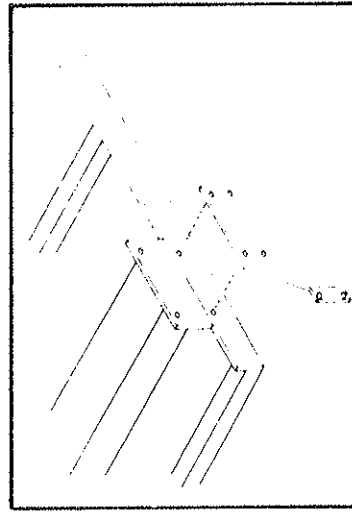

OUTER SPRING BRACKET
(Attach With 5/8" x 1-3/4"
Cap Screws)

3. Attach extensions to mounting brackets with 5/8" x 5-1/2" capscrews and stover lock nuts. Tighten nut so that extension is free to swivel. Install 5/8" x 4-3/4" clevis pins and hair pin cotters. See Figure 20.
4. Install harrow assemblies on extensions so that grease zerks point either upward or rearward. Arrow on upper frame of harrow assembly shows direction of travel. Use 5/8" x 2-1/4" special cap screws (ends are turned down to 1/2" diameter) with stover lock nuts and 1/2" x 1-1/2" capscrews with nuts and lockwashers. The special cap screws are also used to hold spring handles.

Attach spring anchors with 3/8" x 3" capscrews, nuts and lockwashers. Attach springs and handles.

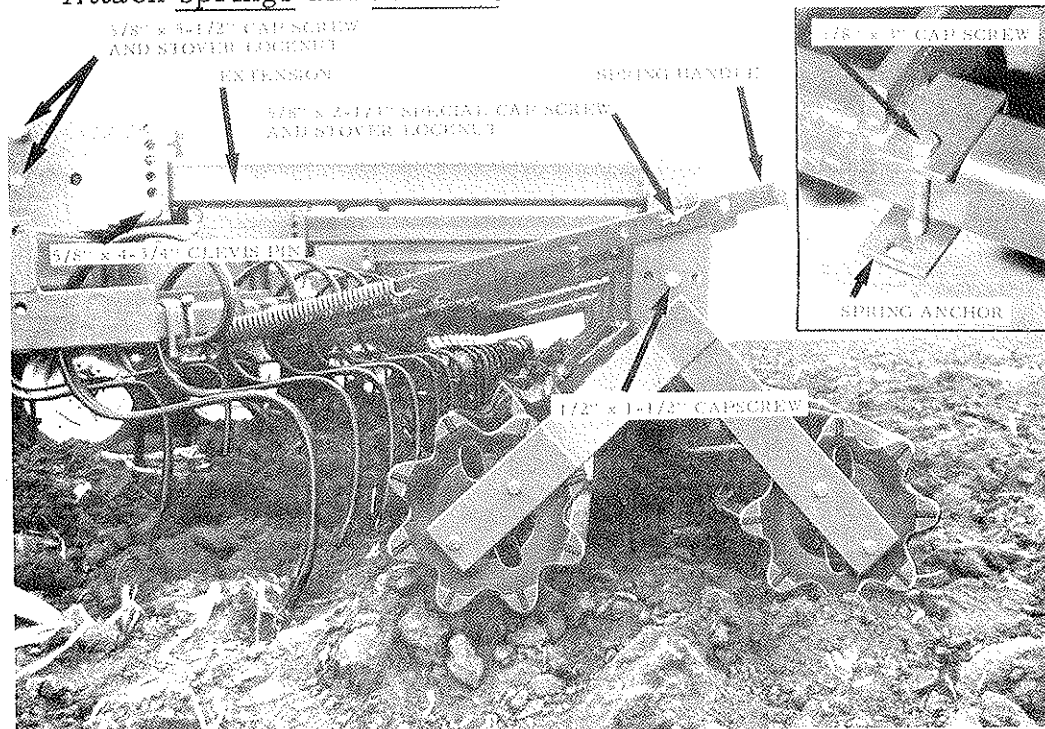

FIGURE 20

Rock Shield Installation

Optional rock shields (4J-985) are available if small rocks become caught between dished ends of harrow reels and frames. Use existing bearing mounting bolts and attach where needed.

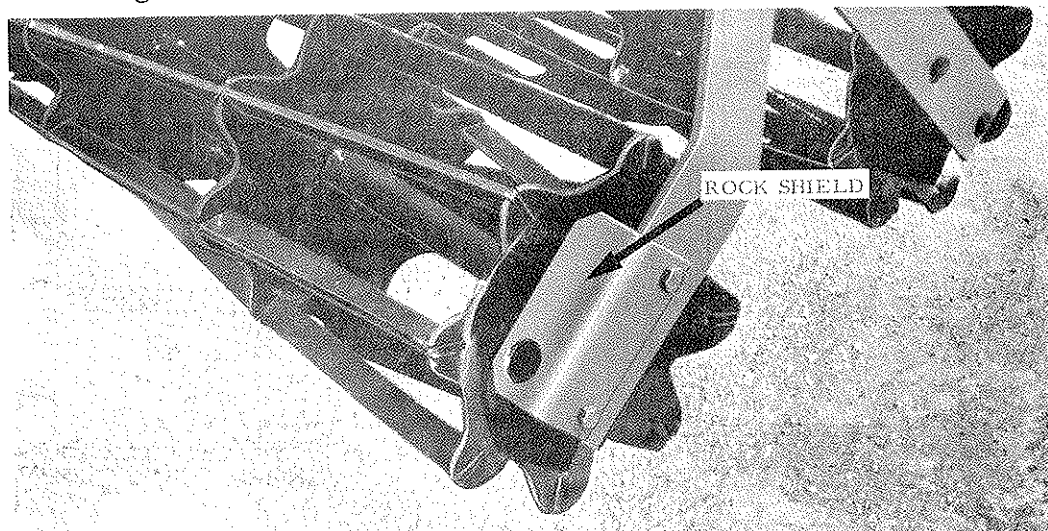

FIGURE 21

Leveler Board Installation

1. Diagrams on pages 36 to 38 show locations of brackets on leveler angles as well as spacing of leveler angles on machine. Use 1/2" x 1-1/4" capscrews, nuts and lockwashers.
2. Mounting brackets fasten to machine frame with 1/2" L-bolts, nuts, and lockwashers.
3. Each mounting assembly uses five 1/2" x 1-3/4" clevis pins with 1/8" x 1" cotter pins. Be sure rounded end of post is downward to permit leveler board to swing.

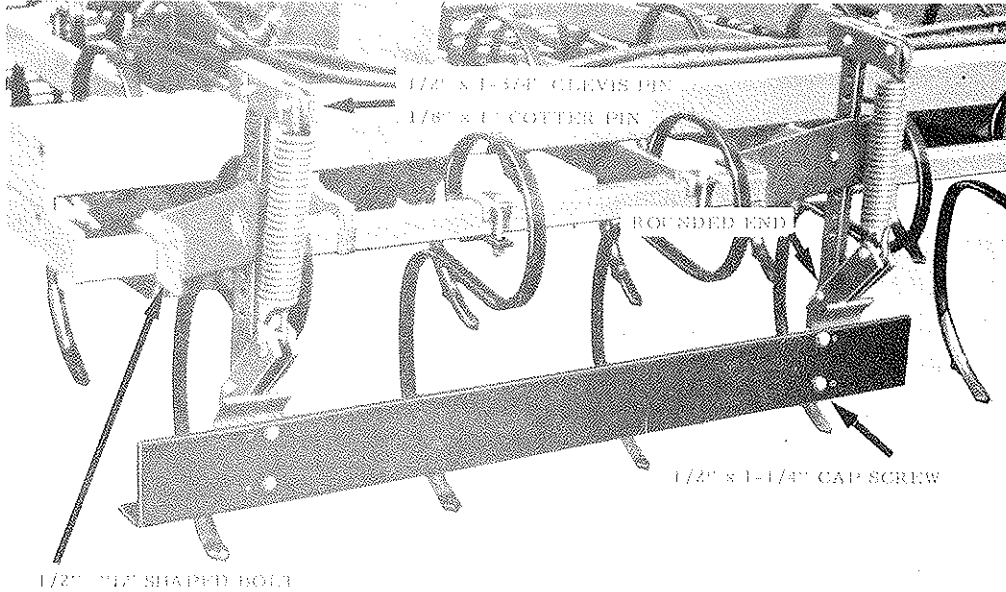

FIGURE 22

Rear Hitch Installation

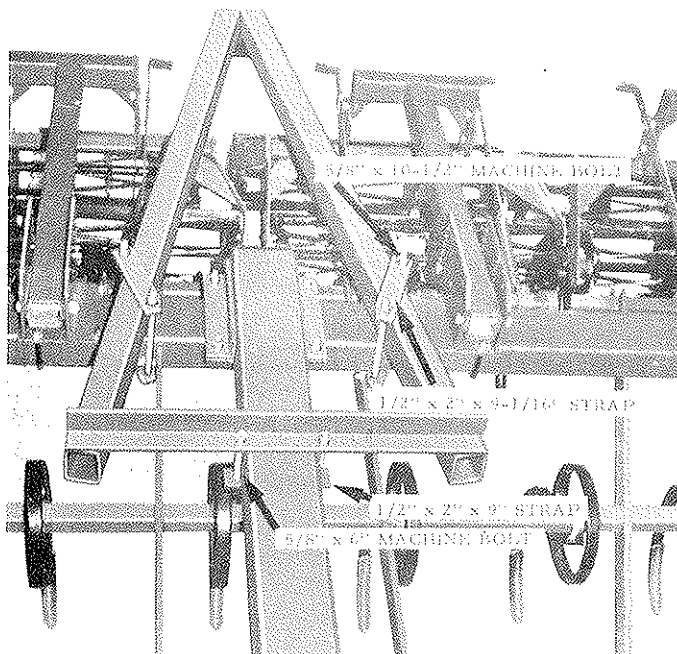
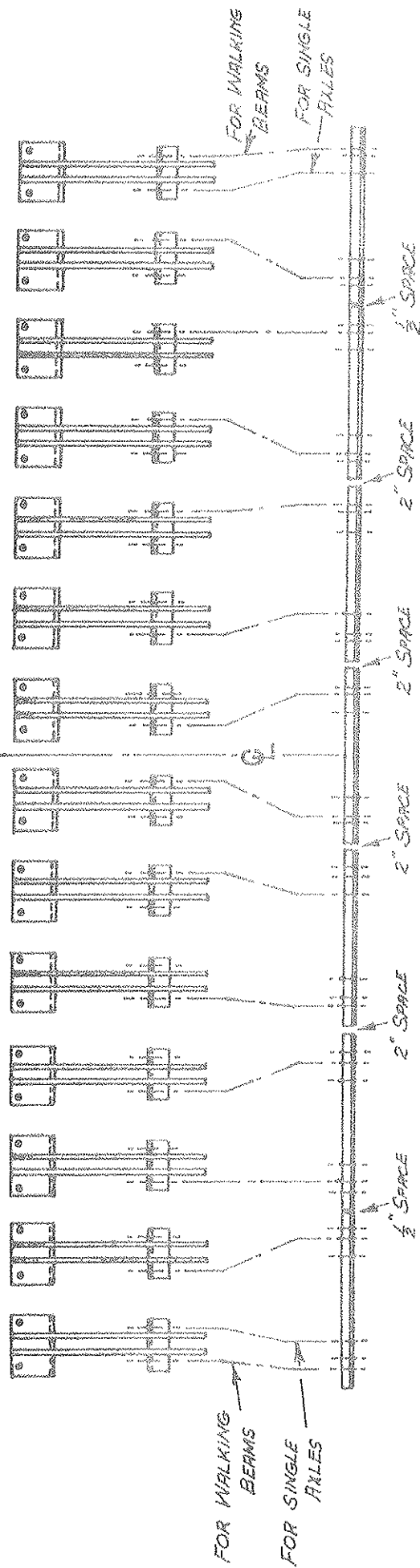

FIGURE 23

LEVELER BOARD INSTALLATION

FULL LENGTH LEVELER FOR 32' 4" MACHINE



FULL LENGTH LEVELER FOR 29' 8" MACHINE

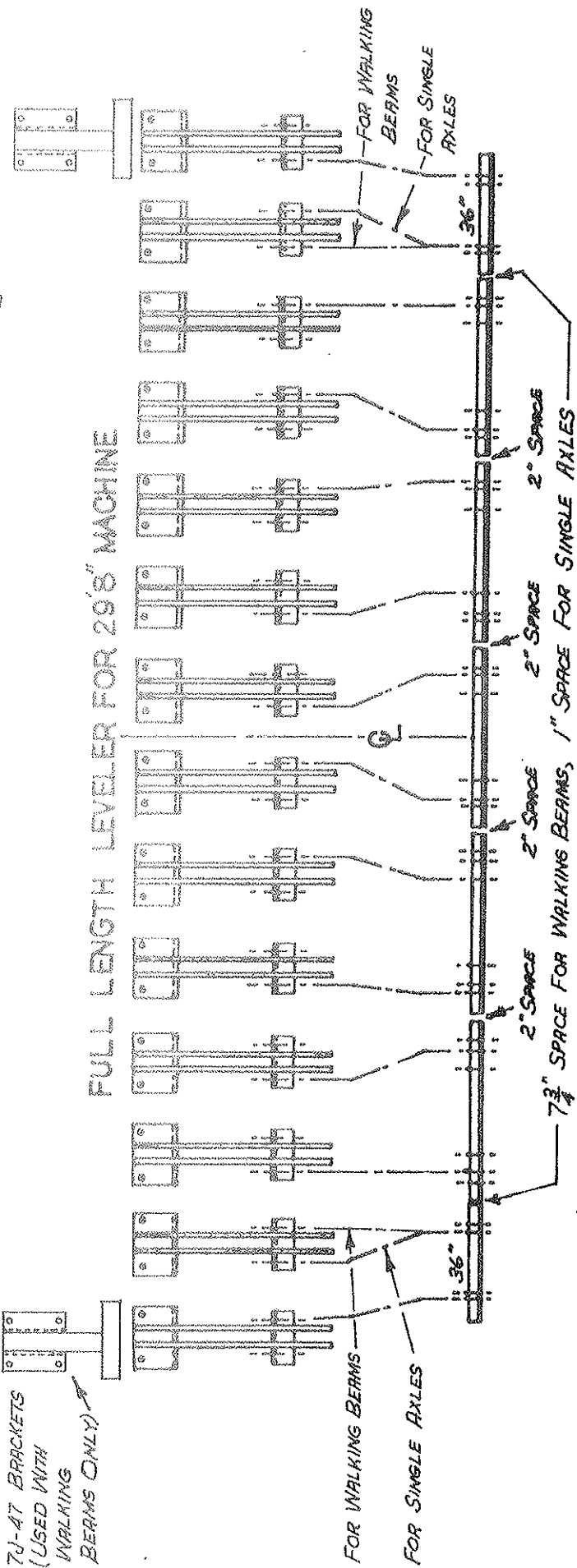

LEVELER BOARD INSTALLATION

FULL LENGTH LEVELER FOR 26'4" MACHINE

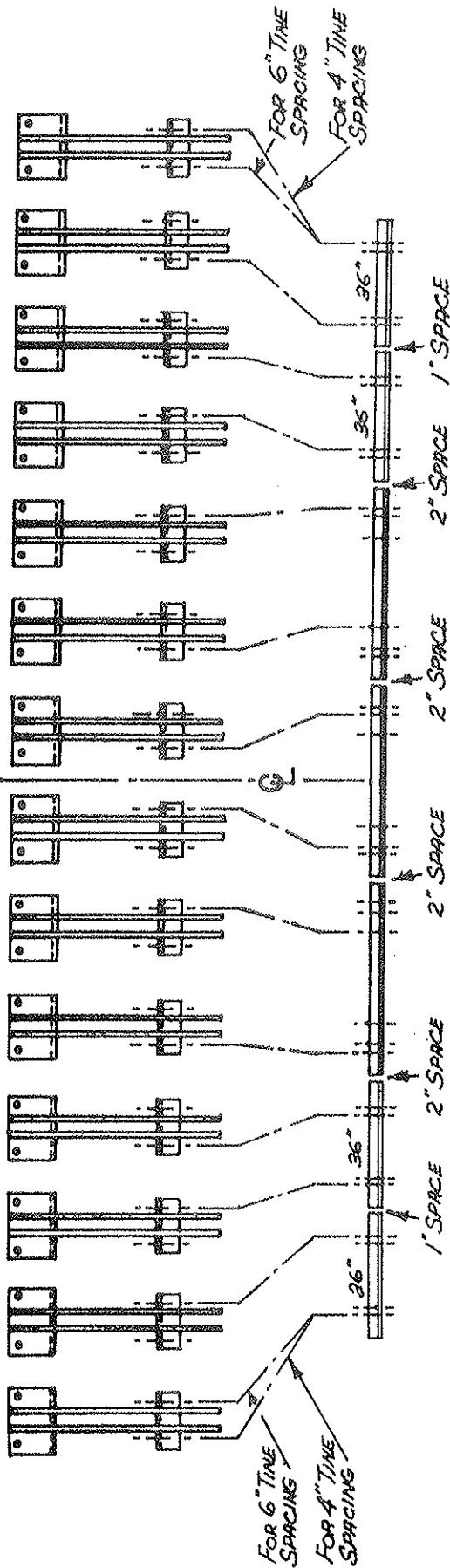

FULL LENGTH LEVELER FOR 238" MACHINE

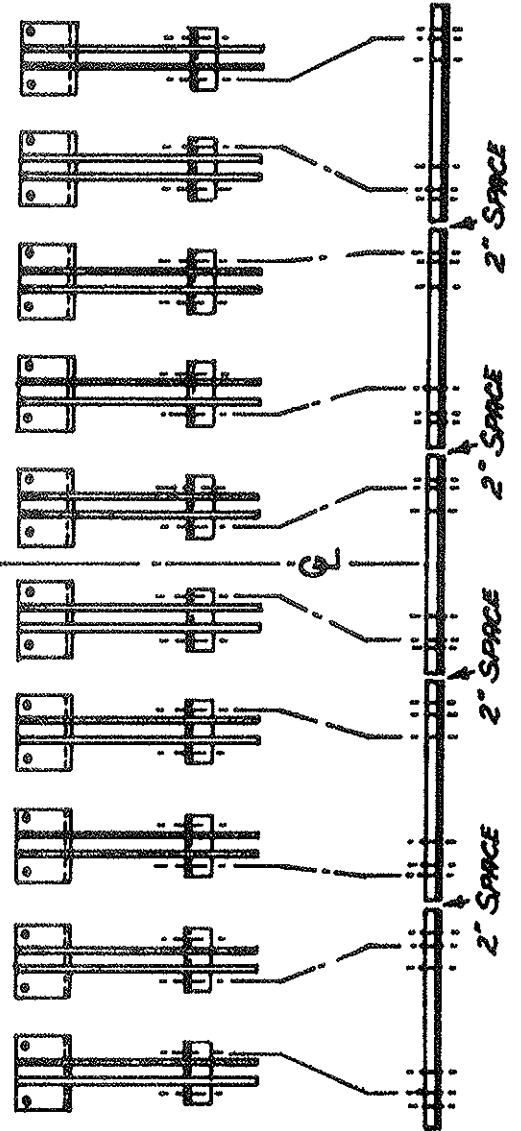

LEVELER BOARD INSTALLATION

WHEEL TRACK LEVELER FOR ALL MACHINES

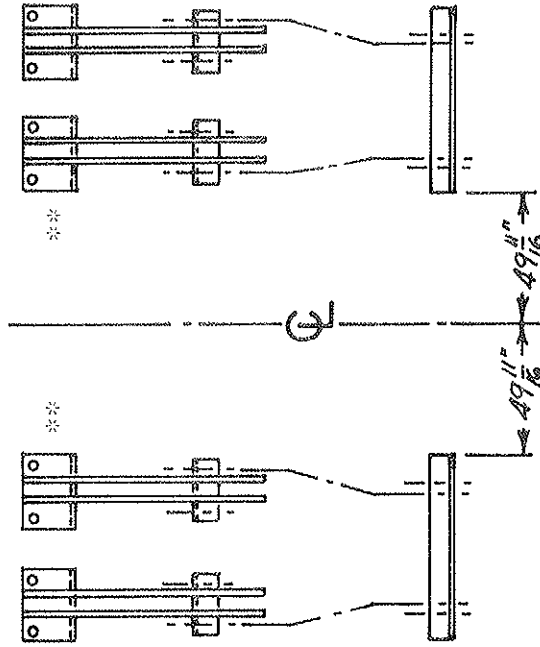
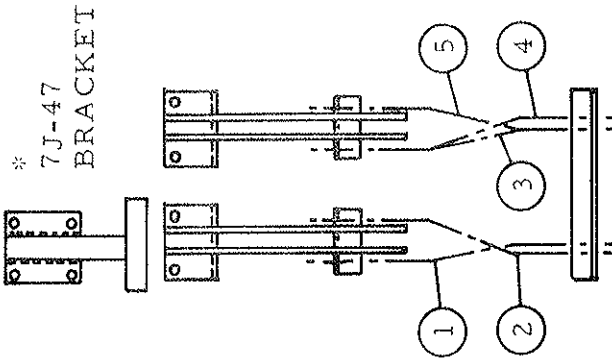

MOUNTING POSITIONS

MODEL	2381	2641	2981	3241
Single Wing Wheel Toward Outside	2 and 4	2 and 4	Does Not Apply	1 and 3
Single Wing Wheel Toward Inside	2 and 4	2 and 4	2 and 3	2 and 3
Walking Beams	2 and 4	2 and 4	2 and 5	1 and 5

* For Model 2981 With Walking Beams Only
 ** With 4" Spacing, Tines Must Be Moved Slightly To Clear These Two Brackets

SPECIFICATIONS

(Subject to Change Without Notice)

Model Identification is as follows:

- C = Cultivator-Incorporator, walking beam axles, standard tines.
- CS = Cultivator-Incorporator, Single axles, standard tines.
- CH = Cultivator-Incorporator, walking beam axles, Heavy tines.
- CSH = Cultivator-Incorporator, Single axles, Heavy tines.

Operating width is indicated with three digits representing feet and inches such as 324 is 32 feet, 4 inches. The fourth digit as in "3241" indicates a model revision. (Name plates are stamped "C1".)

Frame: Main tubes: 6" x 4" x 1/4"
Tooth (tine) tubes: 2" x 2" x 1/4"
Braces: 1/2" x 3"
Depth: 89"
Rank spacing: 29"

Wheels, tires, and axles:

Center frame walking beams: 15 x 6 LB wheels for 7:60 x 15 8 ply tires.
Center frame single axles: 15 x 10 LBH wheels for 12.5L x 15 12 ply tires.
Wing single axles: 15 x 8 LB wheels for 9.5L x 15 6 ply tires.
Wing walking beams: 15 x 6 LB wheels for 7:60 x 15 6 ply tires.

Hydraulics:

Wing - fold: Two 4" x 24" cylinders
Depth control: Four series cylinders - 5" x 8" master with depth control, 4-3/4" x 8" slave, 4-1/2" x 8" slave, 4" or 4-1/4" x 8" slave cylinders.
All connections use 1/2" pipe threads.

Wheel tread dimensions:

Walking Beams

Inner center frame wheels: 10' 3-5/8"
Outer center frame wheels: 13' 10-1/4"
Inner narrow wing wheels: 19' 3"
Outer narrow wing wheels: 22' 9-5/8"
Inner wide wing wheels: 26' 5-3/4"
Outer wide wing wheels: 30' 3/8"

Single Axles

Center frame wheels: 13' 6"
Narrow wing wheels: 19' 8-5/8" or 22' 7-3/8"
Wide wing wheels: 26' 8" or 29' 6-3/4"

Approximate transport dimensions:

Width: 15' 2" with heavy duty tines
Overall length: 19' 9" with rolling harrows in extreme rear position.
Height: Model 2381: 10' 1"
Model 2641: 11' 3"
Model 2981: 13' 0"
Model 3241: 14' 2"

Maximum working depth: 6"

Tines: 10 mm x 32 mm x 22"
(.394" x 1.260" x 22")

12 mm x 32 mm x 22"
(.472" x 1.260" x 22")

12 mm x 32 mm x 26"
(.472" x 1.260" x 26")

Tine spacing: 4" (may also be spaced at 6")

Optional Equipment:

2J-149 1-3/8" reversible point with hardware

2J-150 2-1/2" shovel with hardware

2J-151 4" shovel with hardware

2J-152 7" sweep with hardware

4J-985 Rock shield for rolling harrows

Wheel track and full length leveler boards for all models.

5J-238 Rear hitch kit

6J-670 Vertically adjustable tine with clamp and hardware.

<u>Model</u>	<u>(4" Spacing)</u>	<u>(6" Spacing)</u>	<u>*Approx. Weight (4" Spacing)</u>
C-2381	71	47	5303#
C-2641	79	53	5668#
C-2981	89	59	6024#
C-3241	97	65	6389#
CS-2381	71	47	5051#
CS-2641	79	53	5416#
CS-2981	89	59	5751#
CS-3241	97	65	6115#
CH-2381	71	47	5473#
CH-2641	79	53	5858#
CH-2981	89	59	6234#
CH-3241	97	65	6619#
CSH-2381	71	47	5216#
CSH-2641	79	53	5601#
CSH-2981	89	59	5961#
CSH-3241	97	65	6345#

Rolling Harrow Weights

RH-238	1330#
RH-264	1390#
RH-298	1680#
RH-324	1740#

Leveler Board Weights

Wheel Track	343#
For 2381	480#
For 2641	632#
For 2981	652#
For 3241	672#
7J-51 Bracket Assm. For 2981	27# per Pair

*Points or sweeps will add 1 pound each.