

# ASSEMBLY INSTRUCTIONS OPERATOR'S MANUAL



WIDE (37-Foot through 45-Foot)  
*HFC Field Cultivator*

**MODELS: HFCT37 THROUGH HFCT45  
HFKT37 THROUGH HFKT45**



**MODEL HFCT-40**

BRILLION FARM EQUIPMENT  
BRILLION, WISCONSIN 54110  
[www.brillionfarmeq.com](http://www.brillionfarmeq.com)



# Contents

Introduction.....	3
Location reference.....	3
Parts ordering.....	3
Safety Suggestions.....	4
Safety Warning Signs .....	5
Decal locations .....	7
Pre-operating Checks.....	8
Operating Instructions .....	12
Safety chain .....	12
Prepare for transport .....	12
Prepare for field operation.....	13
Operating depth adjustment .....	13
Maintenance .....	15
Fasteners .....	15
Shanks .....	15
Lubrication.....	15,16
Assembly Instructions.....	17
Frame halves.....	17
Drawbar to Frame .....	18
Center rockshaft and wheels.....	19
Center Section Adjust Rods .....	20
Center section wheel cylinders.....	21
Leveling linkage.....	22
Cylinder anchor attachment .....	23
Wing attachment .....	24
Cylinder attachment to cylinder anchors .....	25
Wing rockshafts and wheels.....	26
Wing adjust rods.....	27
Gage Wheels.....	29
Shanks .....	29
Shank locations .....	32
Hydraulics.....	34
Light Kit .....	35a
Spike Tooth Drags .....	36
Coil Tine Drags .....	43
Trouble Shooting .....	49
Specifications .....	51



# Introduction

To obtain maximum benefits from the BRILLION FIELD CULTIVATOR, please study this manual carefully before starting assembly or operation. A special section, "Assembly Instructions", is included. If items in this manual are not understood, contact your local Brillion dealer.



**BE ALERT!**  
Your Safety Is Involved.

The Symbol Shown Is Used To Call Your Attention To Instructions Concerning Your Personal Safety. This Symbol Is Found On Your Machine - It Points Out Important Safety Precautions. It Means "ATTENTION! - Become Alert! Your Personal Safety Is Involved!" Read The Message That Follows And Be Alert To The Possibility Of Personal Injury Or Death.

## Location Reference

Right hand, left hand, and forward designations are determined by standing behind the machine and facing the direction it will travel during field operation.

## Parts Ordering

When ordering parts for this machine, include the complete model number and serial number. Refer to the name plate on the drawbar as shown in Figure 1. Please read and record this number upon taking delivery of this machine.

FIELD CULTIVATOR Model \_\_\_\_\_

Serial Number \_\_\_\_\_

Date Purchased \_\_\_\_\_

Be sure to read the warranty card which is shipped with the machine. Return the proper portion of the card for recording at the factory.

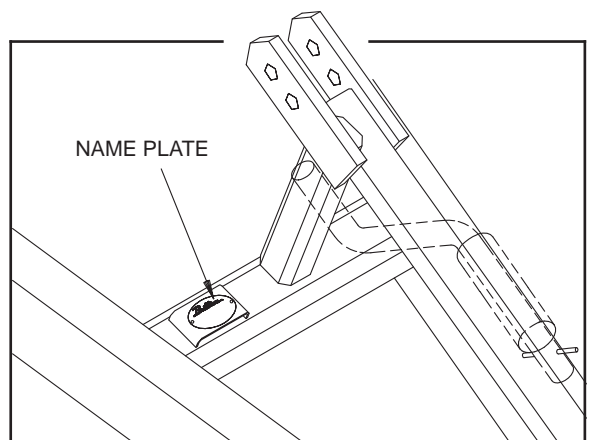



## SAFETY SUGGESTIONS



Federal law requires you to explain the safety and operating instructions furnished with this machine to all employees before they are allowed to operate the machine. These must be repeated to the employees at the beginning of each season. Be sure to observe and follow the instructions for the safety of anyone operating or near the machine.

Investigation has shown that nearly 1/3 of all farm accidents are caused by careless use of machinery. You can do your part in improving safety by observing the following suggestions. Insist that all people working with you or for you abide by them.

1. Do not stand between the tractor and implement when attaching or detaching implement unless both are not moving.
2. Before applying pressure to the system, be sure all connections are tight and that hydraulic lines and hoses are not damaged. Check the system again while cycling.
3. Escaping fluid under pressure can be nearly invisible and have enough force to penetrate the skin causing serious injury. Use a piece of cardboard or wood, rather than hands, to search for suspected leaks. If injured by fluid, see a doctor at once.
4. Do not make adjustments or lubricate machine while it is in motion.
5. Do not allow anyone to ride on tractor or machine.
6. Always use transport locks while transporting the machine.
7. Do not transport at speeds over 15 mph.
8. Avoid sudden stops or turns when transporting because the weight of machine may cause operator to lose control of tractor. Use a tractor heavier than the machine. Do not allow tractor drawbar to swing when in transport.
9. Use caution when towing behind articulated steering tractors; fast or sharp turns may cause the machine to shift sideways.
10. When transporting the machine on a road or highway, use adequate warning symbols, reflectors, lights, and slow moving vehicle signs as required. Use a safety chain.
11. Block machine so it will not roll when unhitched from tractor.
12. Relieve pressure in hydraulic lines before uncoupling hydraulic hoses from tractor. On most tractors this can be done by operating valves after engine is stopped.
13. Securely block machine when working on or under it to prevent injury in case of hydraulic failure or inadvertent lowering by another person.
14. Lower machine to ground when not in use.
15. Do not fold or unfold wings without first bleeding all air from the hydraulic circuit.
16. Know the height of your machine in the folded position, do not fold the wings under low power lines or other obstructions.
17. Fold wings on as level a surface as possible.



## **SAFETY WARNING SIGNS**

The “WARNING” signs and their locations illustrated on the following two pages are placed on the machine to warn of hazards. “The warnings found on the signs are for your own personal safety and that of those around you.” **OBSERVE THESE WARNINGS!**

There are three levels of hazard intensity that appear with the safety alert symbol on safety decals: **DANGER, WARNING, and CAUTION.** Hazard intensity is defined as follows:

**DANGER -** Immediate hazards which **WILL** result in severe personal injury or death.

**WARNING -** Hazards or unsafe practices which **COULD** result in severe personal injury or death.

**CAUTION -** A reminder of safety practices, or an alert to unsafe practices which could result in personal injury.

Keep these signs clean so they can be observed readily. Wash with soap and water or cleaning solution as required.

Replace “WARNING” signs should they become damaged, painted over or if they are missing.

When replacing decals, clean the machine surface thoroughly using soap and water or cleaning solution to remove all dirt and grease.

# DANGER



HARROWS OR OTHER DEVICES MOUNTED ON THE REAR OF THIS MACHINE WILL USUALLY MAKE IT DRAWBAR-LIGHT. TO AVOID PERSONAL INJURY FROM MACHINE TIPPING REARWARD, ALWAYS LOWER MACHINE TO GROUND BEFORE DISCONNECTING TRACTOR. SEE OPERATOR'S MANUAL FOR DETAILS.

5J333

# CAUTION



1. DO NOT LUBRICATE, ADJUST OR REPAIR WHEN MACHINE IS IN MOTION.
2. DO NOT TOW OR TRANSPORT FASTER THAN 15 MILES PER HOUR.
3. DO NOT RIDE OR ALLOW OTHERS TO RIDE ON THE MACHINE.
4. BLOCK UP ALL HYDRAULICALLY OR MECHANICALLY RAISED COMPONENTS TO PREVENT UNINTENDED LOWERING OR LOWER THE MACHINE TO THE GROUND TO MAKE ADJUSTMENT OR REPAIRS WHEN NOT IN USE.
5. KEEP ALL PERSONS AWAY FROM MACHINE DURING HITCHING AND OPERATING.
6. SLOW DOWN BEFORE MAKING SHARP TURNS OR USING THE BRAKES. DRIVE SLOWLY OVER ROUGH GROUND, SIDE HILLS, AND AROUND CURVES TO AVOID TIPPING.
7. COMPLY WITH ALL LAWS WHEN TRANSPORTING THE MACHINE ON PUBLIC ROADWAYS.
8. INSTRUCT ALL OPERATORS IN THE SAFE OPERATION OF THE MACHINE. REVIEW THE OPERATOR'S MANUAL FOR CORRECT PROCEDURES.
9. BLOCK IMPLEMENT TO PREVENT MOVEMENT WHEN UNHITCHED FROM TRACTOR.

8J310

2.--8J310  
Yellow & Black

13.--6J376  
Red & White

# DANGER



**STAND CLEAR WHEN RAISING OR LOWERING WINGS.**



# DANGER

6J376

# DANGER



FALLING WINGS CAN CAUSE INJURY OR DEATH. STAND CLEAR WHEN WINGS ARE BEING RAISED OR LOWERED.

8J310

# DANGER



WATCH FOR ELECTRICAL WIRES AND OTHER OVERHEAD OBSTRUCTIONS WHEN FOLDING WINGS. FAILURE TO HEED THESE WARNINGS MAY RESULT IN PERSONAL INJURY OR DEATH.

9J629

6.--9J629  
Red & White

5.--3K706  
Orange,  
Black &  
White



# WARNING



**DO NOT GO NEAR LEAKS**  
HIGH PRESSURE OIL EASILY PUNCTURES SKIN CAUSING SERIOUS INJURY, GANGRENE OR DEATH.

IF INJURED, SEEK EMERGENCY MEDICAL HELP. IMMEDIATE SURGERY IS REQUIRED TO REMOVE OIL.

DO NOT USE FINGERS OR SKIN TO CHECK FOR LEAKS.

LOWER LOAD OR RELIEVE HYDRAULIC PRESSURE BEFORE LOOSENING FITTINGS.

10813A

# DANGER



BLEED THE AIR FROM WING LIFT CYLINDERS BEFORE OPERATING. FAILURE TO DO SO WILL ALLOW WINGS TO FREE-FALL AND MAY CAUSE SERIOUS PERSONAL INJURY. SEE OPERATOR'S MANUAL FOR CORRECT PROCEDURE.

3J678

3.--3J678  
Red & White

11.--2J431 - Amber  
12.--2J430 - Red



## DECAL LOCATIONS

1. 5J333 - DANGER, "ROLLING HARROWS..."
2. 8J310 - CAUTION LIST
3. 3J678 - DANGER, "BLEED THE AIR..."
4. 3J675 - DANGER, "FALLING WINGS..."
5. 3K706 - WARNING, HYDRAULIC LEAKS
6. 9J629 - DANGER, ELECTRICAL HAZARD
7. 4K036 - "BRILLION" 2 3/4" x 20"
8. 4K039 - "BRILLION" 3 3/4" x 40"
9. 4K037 - "BRILLION" 2 3/4" x 32"
10. 4K038 - "FIELD COMMANDER"
11. 2J431 - REFLECTIVE AMBER
12. 2J430 - REFLECTIVE RED
13. 6J376 - DANGER, "STAND CLEAR..."

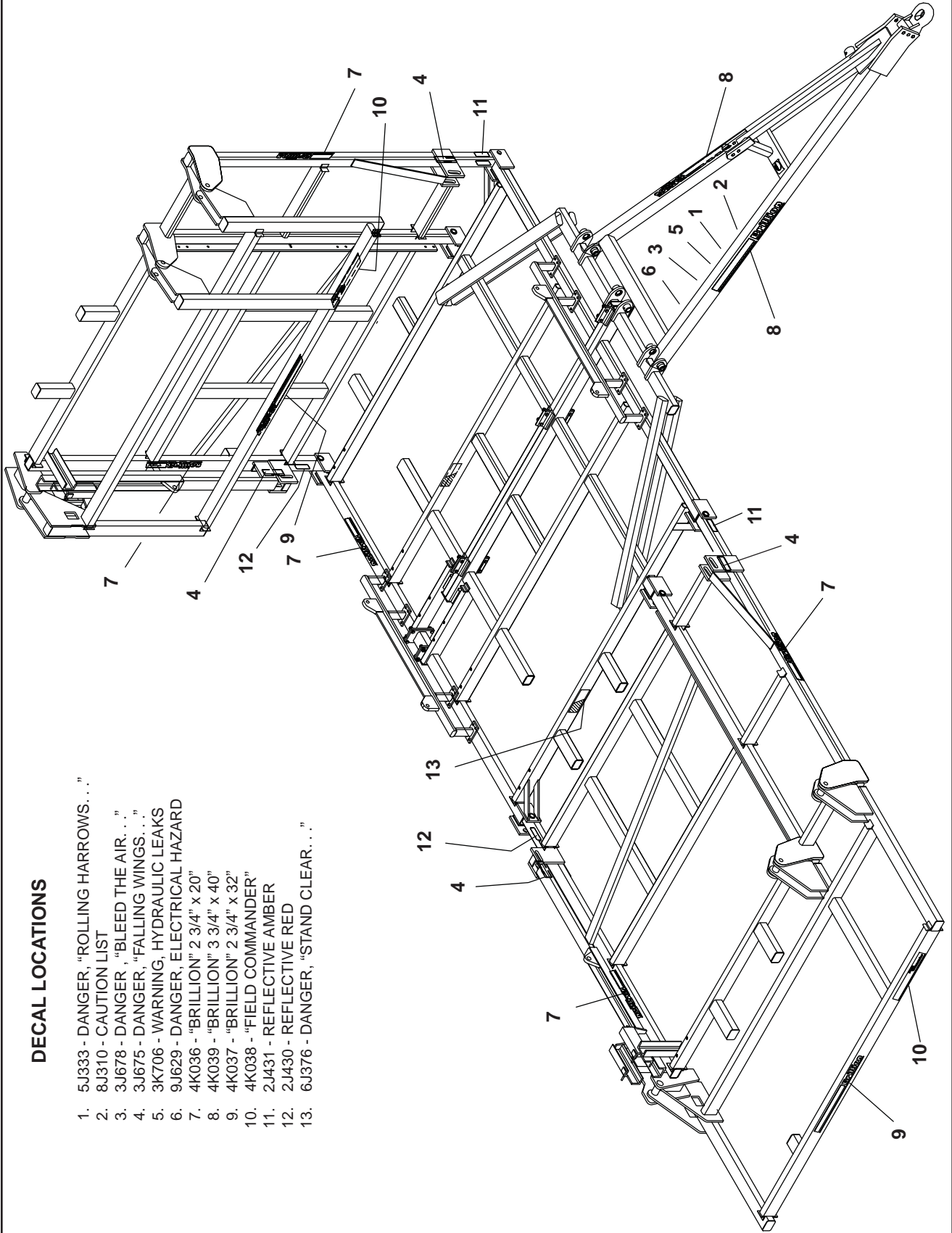

## PRE-OPERATING CHECKS

### Hydraulic cylinders



Before raising or lowering the wings, be sure that the wing lift cylinders are properly bled (all air is removed from the hydraulic circuit). Improperly bled cylinders will permit the wings to free-fall, possibly causing injury to the operator and damage to the machine.

Bleed the system by removing the rod end pins which connect the cylinder to the wing and fully extend and fully retract the cylinders three or four times. Reconnect the cylinder rod ends to the wings.

Check to make sure that flow restrictors have been installed in the wing lift circuits. These are screwed into the rod end port of all 4 wing lift cylinders, and also into the base end port of the two outer wing cylinders. These restrictors control the passage of oil to and from the wing lift cylinders and prevent the wings from falling too rapidly.

### Tractor hydraulic level

The wing lift and depth control cylinders are shipped from the factory without oil in them. All 12 cylinders must be charged with oil, they will use approximately 14 gallons of oil. Check your tractor hydraulic level to avoid any damage to the system.

### Three point hitch position

Before moving the implement, be sure the three point lift arms of the tractor have been raised to avoid damaging the tongue on the cultivator when making sharp turns.

### Jack

Make sure the jack has been moved to its storage position on the drawbar and pinned in place.

### Level adjust

Because this field cultivator has different diameter tires on the center section than it does on the wings, it is important to follow these leveling instructions exactly.

The depth adjust rods for the center section must be adjusted equally to prevent damage to the center axle.

1. Unfold the wings of the field cultivator. **Be sure to hold the control lever to the extend position until the wing lift cylinders are completely extended.**
2. **Operate the hydraulic control lever for the wheel cylinders to the extend position and hold it there until there is no movement in any of the wheel cylinders.**
3. **Measure the pin center distances of the wheel cylinders(See figure 3):**  
If they are all the same, (approximately 28 1/4"), proceed to step #6.  
If the pin centers differ, retract the cylinders and measure the pin centers. If they are not all the same length, (approximately 20 1/4"), adjust the rod end clevis as necessary so that all cylinders are the same length. Make sure that the rod end thread engages the clevis completely, and that the locking bolt on the cylinder clevis is tightened.

4. Extend the cylinders and hold the control lever in the extend position until there is no motion in any of the cylinders. Check the pin center distances. If they are not all approximately 28 1/4", retract the cylinders and disconnect the pins from the wheel arms and the cylinder anchors. Bleed any air from the hydraulic circuit by positioning all the wheel cylinders with the rod ends higher than the rest of the cylinder and then extending and retracting the cylinders at least three times. *At the end of each extend stroke, hold the hydraulic control lever at least 30 seconds.*
5. Retract the cylinder rods, and reconnect the cylinders to the cylinder anchors and wheel arms.
6. Use the hydraulic lever to move the wheels so that the tooth points of the CENTER SECTION are just barely above the ground line.

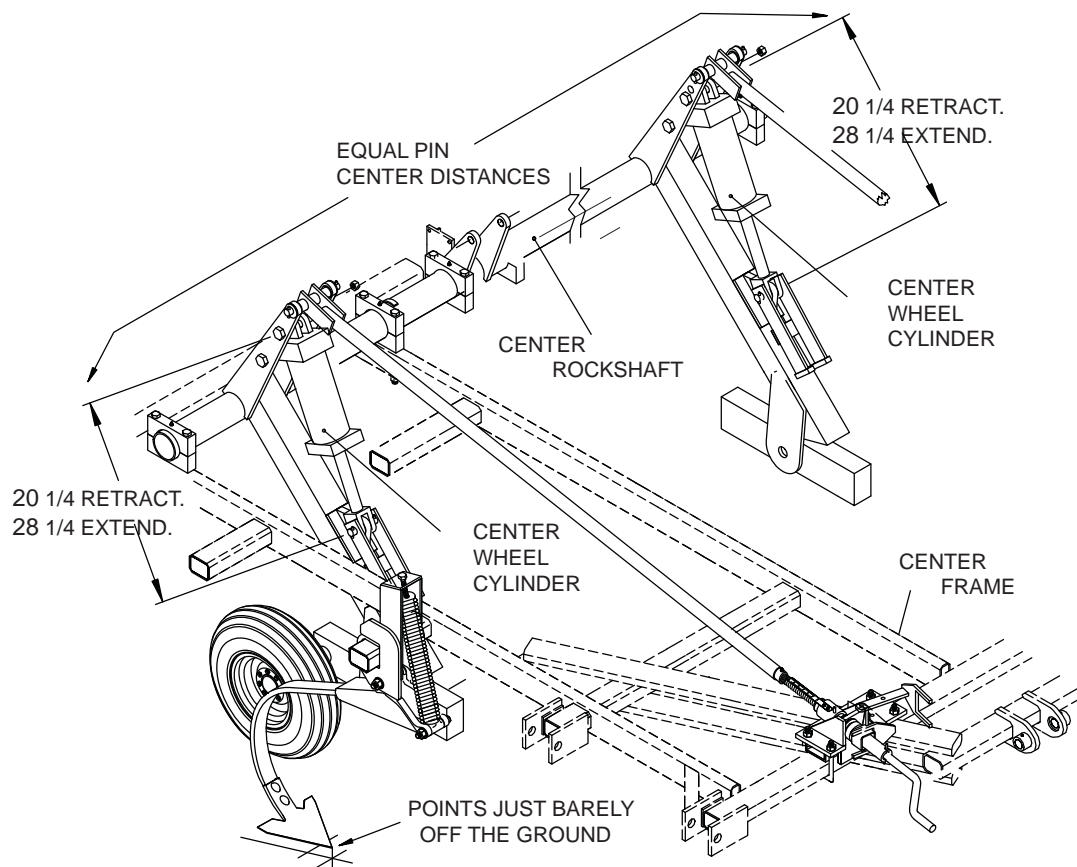

**FIGURE 3**

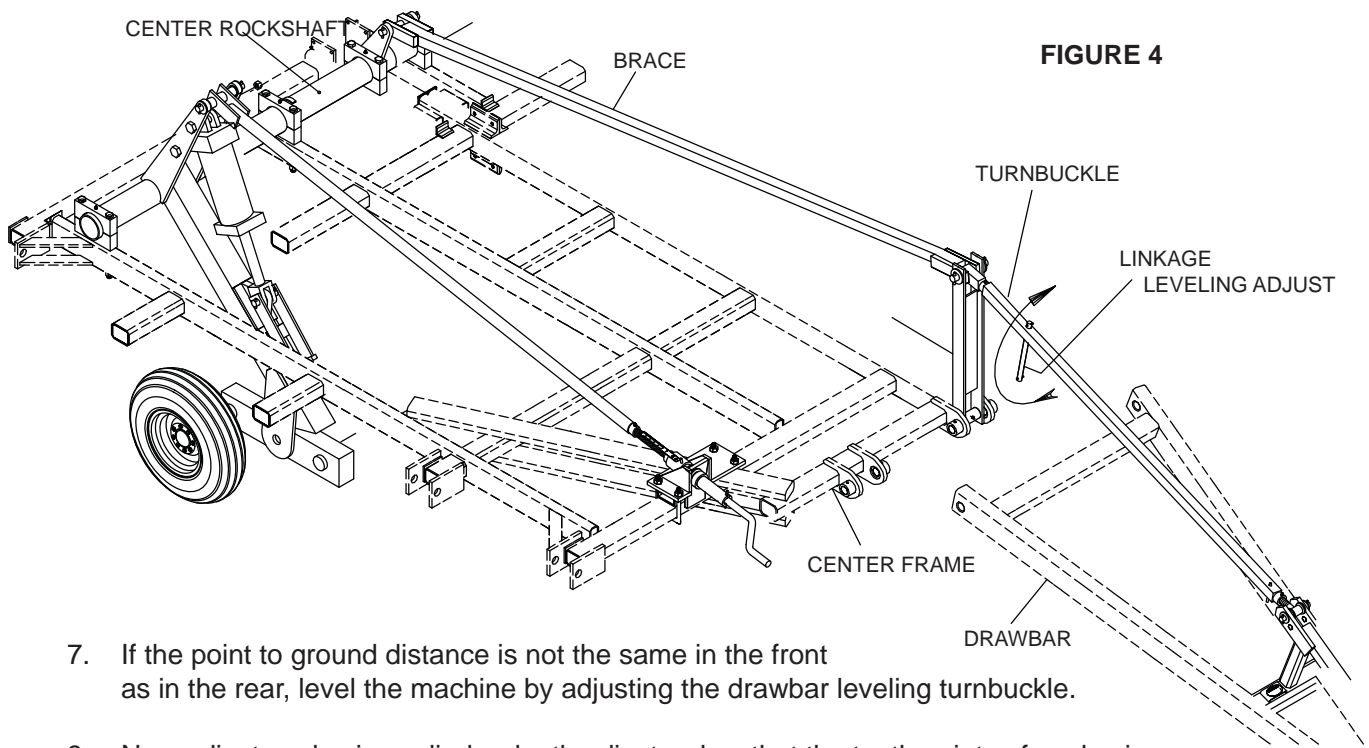

FIGURE 4

7. If the point to ground distance is not the same in the front as in the rear, level the machine by adjusting the drawbar leveling turnbuckle.
8. Now adjust each wing cylinder depth adjust rod so that the tooth points of each wing section are the same distance from the ground as those on the center section.

**Note:** You will have to lower the machine onto the tooth points to be able to turn the adjust screw. Each turn changes the point position by approximately 5/16 inch (three turns equals one inch.)

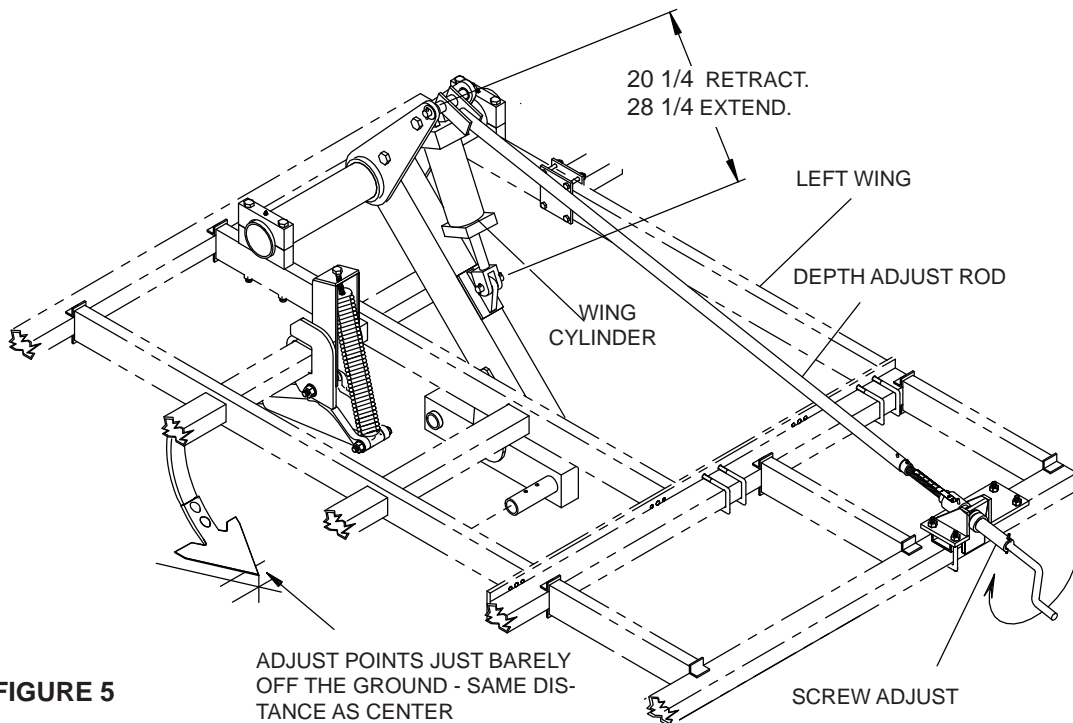

FIGURE 5

9. After each adjustment, completely raise the field cultivator, hold the hydraulic control in the extend position, and then lower the machine until the tooth points are just barely off the ground.

**Note:** During the leveling procedure, the front gage wheel is not supporting the frame and the outside front teeth of the cultivator wing may touch the ground first. This will be eliminated in the operation, by adjusting the front gage wheel.

**Note:** The machine is designed so that the rear will raise slightly more than the front. This is done so that if you have drags mounted to the cultivator, there will be adequate ground clearance in transport. Therefore the cultivator will not be exactly level in the transport position.

## OPERATING INSTRUCTIONS



**DO NOT** allow others on or near the tractor and the machine when operating or preparing to operate the machine.

### Prepare the machine for transport

1. Extend the transport wheel cylinders completely. These are series cylinders and are designed to raise the machine evenly. The cylinders will rephase or equalize at the end of their stroke. Simply continue to hold the hydraulic control lever of the tractor in the extend position until all cylinders in the system are completely extended. Do this occasionally during operation at the end of the rows to make sure that the cylinders remain in phase.
2. With the machine in the up or transport position, raise the wings to folded position.



Know the folded height of your field cultivator and any attachments. Be sure that you are not under any electrical lines or any other obstruction that could cause injury to the operator or damage to the equipment.

3. Use the transport locks to lock the machine in the transport position.



Maximum road speed is 15 MPH under good conditions. Do not tow the machine at a speed at which the operator loses control of his vehicle. Do not tow the cultivator with a vehicle that is lighter than the cultivator.

It is the responsibility of the owner/operator to comply with all applicable laws regarding slow moving vehicle signs, warning lights, reflectors, and safety chains.

### Safety Chain

Use of a safety chain is recommended if the machine is towed on a public road or highway. Total weight of towed machine must not exceed chain capacity as shown on the chain's identification tag. A safety chain is included with the cultivator.

Slack in the chain should be only enough to permit turning. Distance from hitch pin to attachment point or intermediate support should not exceed 9".

#### **CAUTION**



If two or more machines are pulled in tandem, a larger chain may be required. Chain capacity must be greater than the total weight of towed implements. A second chain should be used between each implement.

#### **CAUTION**



Replace chain if one or more links are broken, stretched, or otherwise damaged or deformed.

Keep attaching hardware fastened securely.

If bolts are replaced, be sure to use grade 5 or higher.

If you have any questions regarding the safety chain call your Brillion dealer.

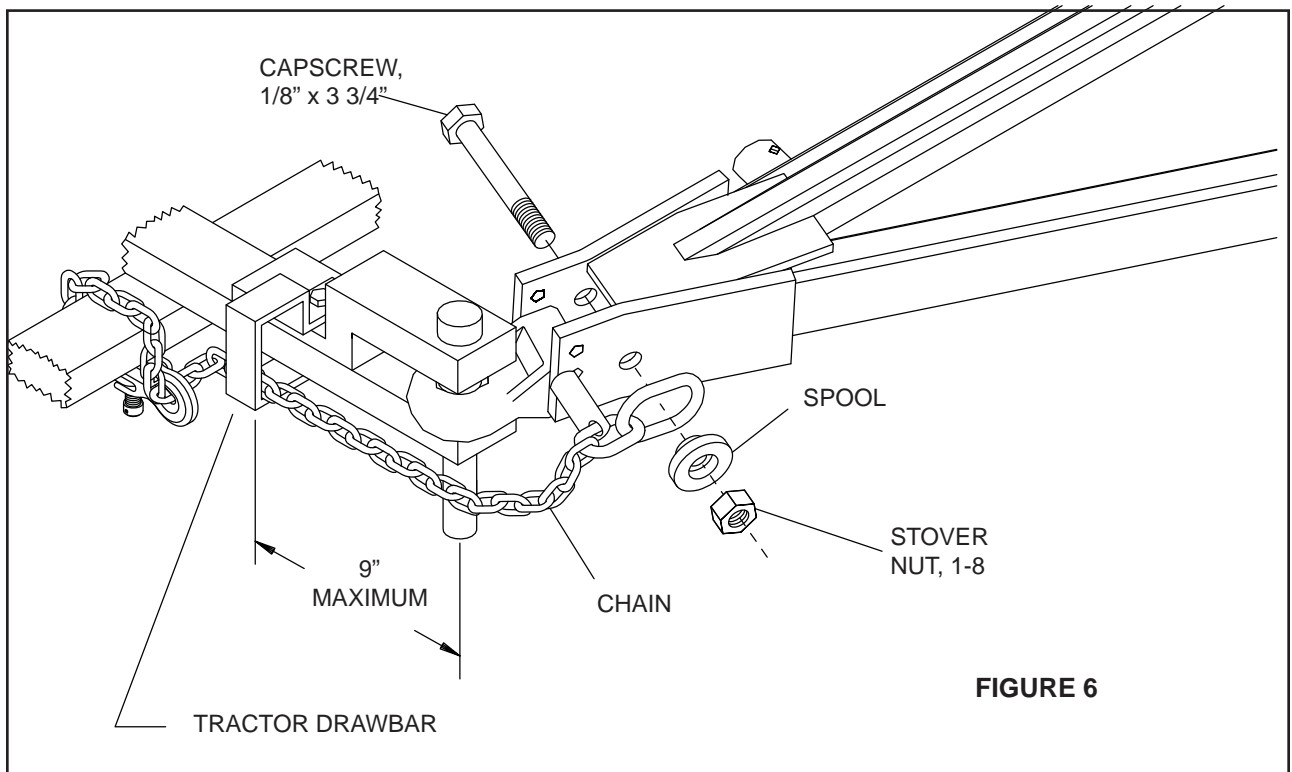

### **Prepare the machine for field operation**

1. Raise the machine fully on its transport wheels.
2. Flip the transport locks on both center axle lift cylinders into their storage positions.
3. Lower the wings by extending the wing lift cylinders. Make sure that the cylinders are extended completely; this will allow the wings to float down to follow the contour of the ground.

### **Operating depth adjustment**

1. With the machine leveled, the transport locks rotated down, and the wings unfolded, set the approximate working depth by adjusting the cylinder anchor brace rods. The scales on the anchor adjust rods are used to make sure that the brace rods are set equally. The wing operating depth can be adjusted independently of the center section by changing the anchor rod length as required. Shortening the brace tube raises the wing, decreasing the operating depth. Lengthening the brace tube increases operating depth. One turn of the adjust tube increases or decreases operating depth by approximately 5/16" (3 turns for 1 inch of depth).

**Note:** Lower the machine onto the shanks to turn the adjust tubes.

**Important:** Adjust both anchor braces on the center section equally. Unequal length braces will put a strain on the center axle, center frames, and on hydraulic cylinders.

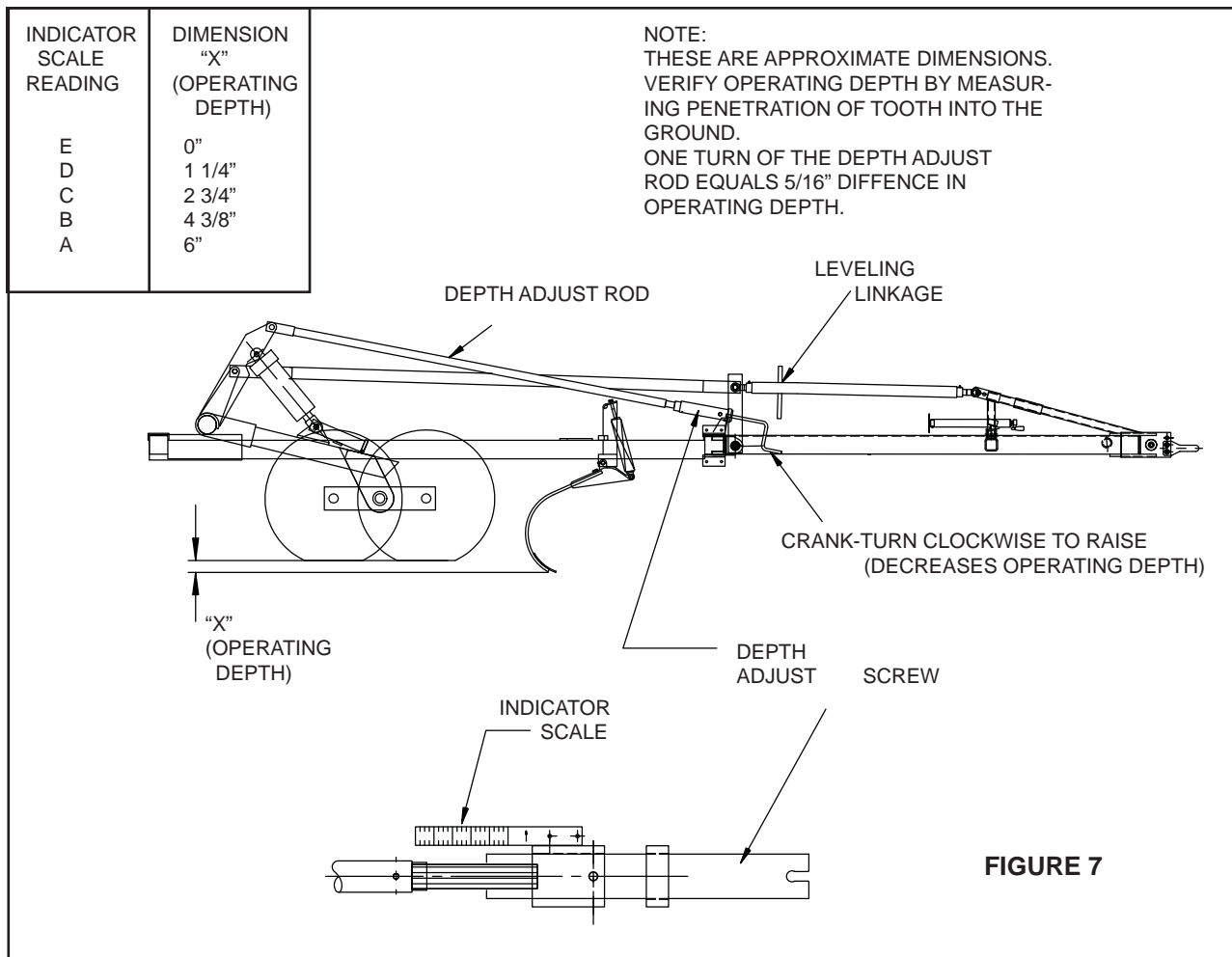

- Level the machine front to rear by adjusting the leveling linkage as required. Lengthening the linkage raises the front, shortening the linkage lowers the front.

**NOTE:** In operation, the adjustment of wing gage wheels will probably be different than the center section. This is due to the difference in tires and also because the wheels of the center section are probably following in the tractor tire tracks. **The best way to check if the machine is level, is to make all the adjustments with the tooth points just above ground on a level surface. Then lower the machine into the ground and drive forward several feet. Now, stop, slowly raise the machine and watch as the sweeps of the field cultivator come out of the ground. They should all come out at the same time. If the front of the machine comes out of the ground before the rear, lower the front of the cultivator. If the wings come out of the ground before the center, set the wings to operate deeper and vice versa.**

- After the machine has been leveled in the operating position, operate a few feet and verify the operating depth. The depth can now be changed by adjusting all brace rod tubes equally.



## MAINTENANCE

### Fasteners

After a few hours use, check entire machine and tighten any loose nuts or bolts. Daily or periodic checks should be made thereafter.

### Shanks

After 5 hours of operation, and every 50 hours thereafter, check to make sure that the shank pivot bolts are tight. Loose pivot bolts will permit the bushing to rotate in the spring holder causing the holes to wear, resulting in sloppy shank support.

### Lubrication

Lubricate your field cultivator at the locations shown in figure 9. The number in the lubrication symbol indicates the hourly interval between greasing.

Always lubricate your field cultivator before taking it to the field for the first time.

Lower the implement onto the shanks before greasing.

Replace any missing fittings and clean all fittings before greasing.

Wheel bearings and walking beam bearings should be repacked annually. Follow the disassembly and reassembly procedures below in figure 8 when repacking these bearings.

When the machine is not to be used for some time, exposed portions of the cylinder rods should be cleaned and covered with a thick coat of grease. This will prevent corrosion which will damage seals.

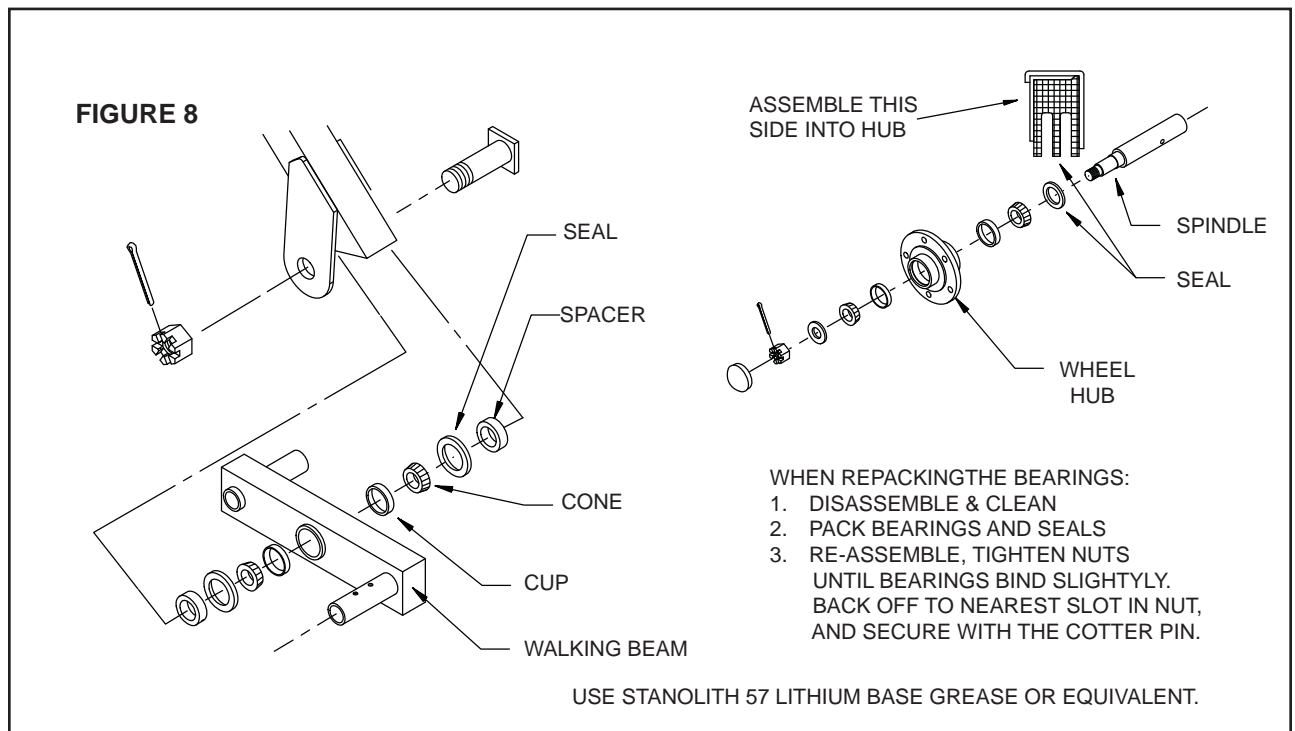

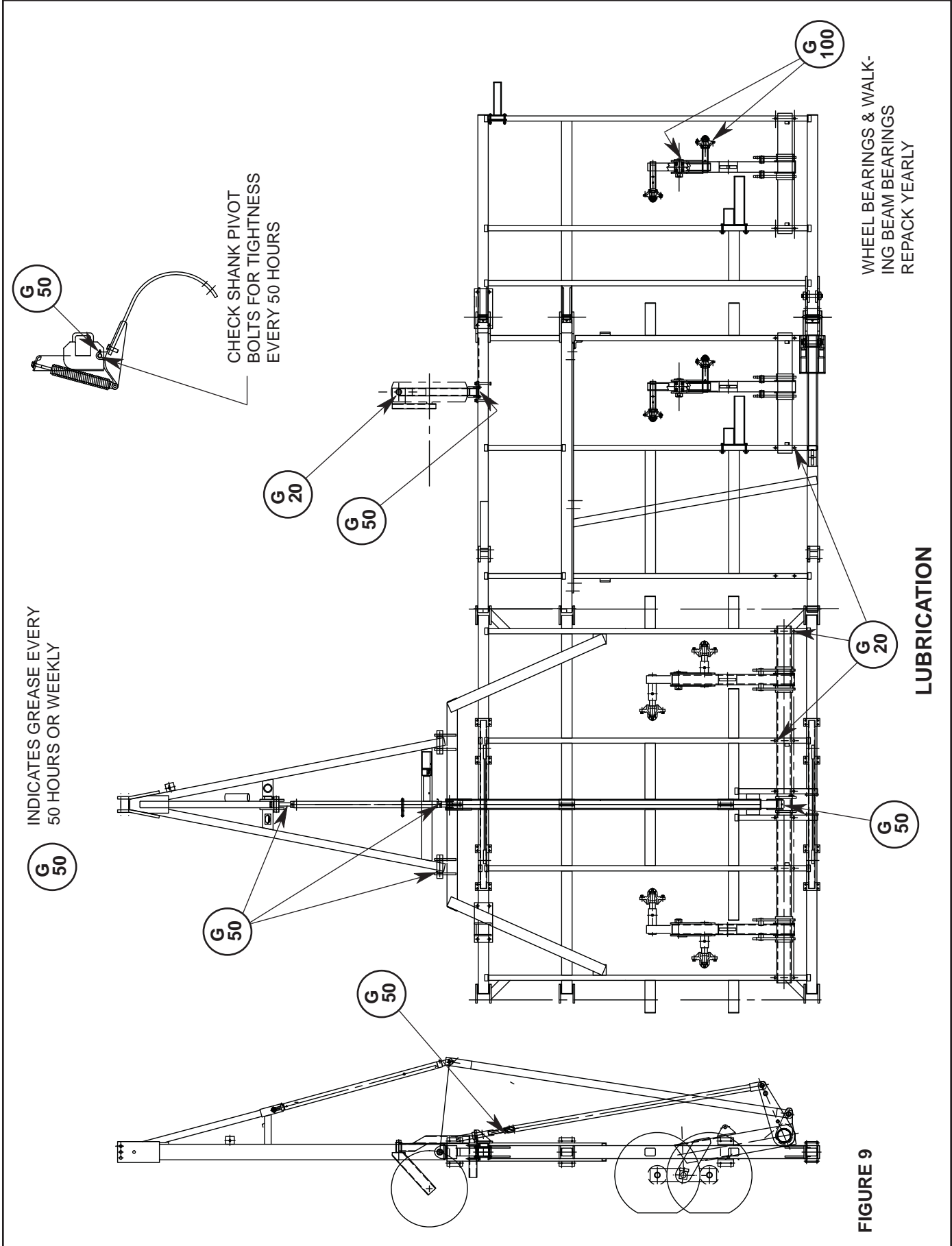

FIGURE 9

## ASSEMBLY INSTRUCTIONS

### ASSEMBLE CENTER FRAME AND DRAWBAR

**Note:** After machine is completely assembled, lubricate it according to figure 9. This will prevent corrosion during storage.

1. Select a smooth level area that can be reached by a hoist or lift truck.
2. Turn the two identical center frame pieces so that they form left and right machine halves, and position them on blocks so that the connecting angles are adjacent to each other.
3. Place the tooth bar between the two frames at the rear.

*Do not tighten any hardware until told to do so.*



**Do Not Work Under Machine Unless it is Blocked Up Securely.**

4. Fasten the tooth bar to the center frames with (8) 1/2" x 2" cap screws. Loosely attach 1/2" locknuts to the cap screws.
5. Join the connecting angles of the two center frames with (12) 1/2" x 2" cap screws. Loosely attach 1/2" locknuts to the cap screws.

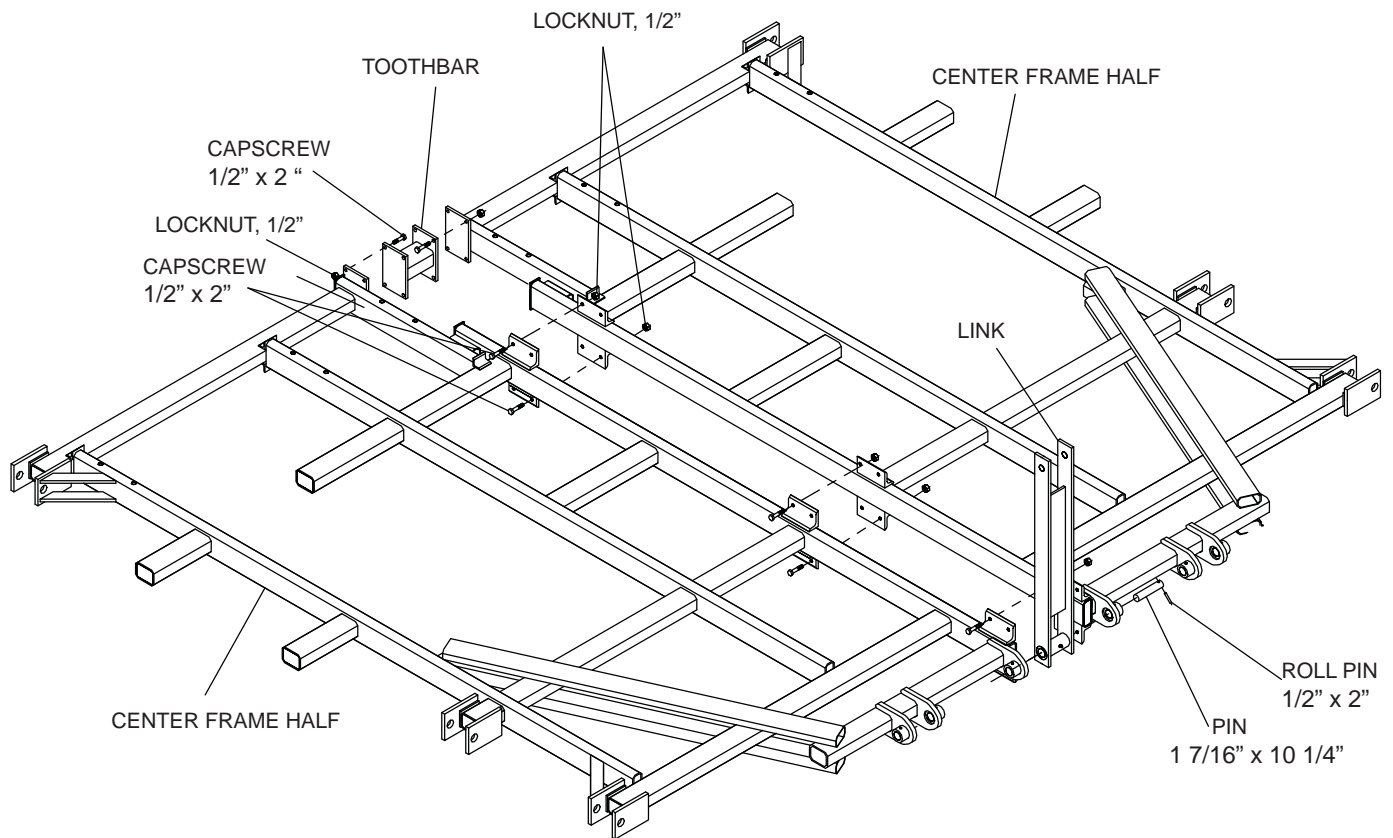

**FIGURE 10**

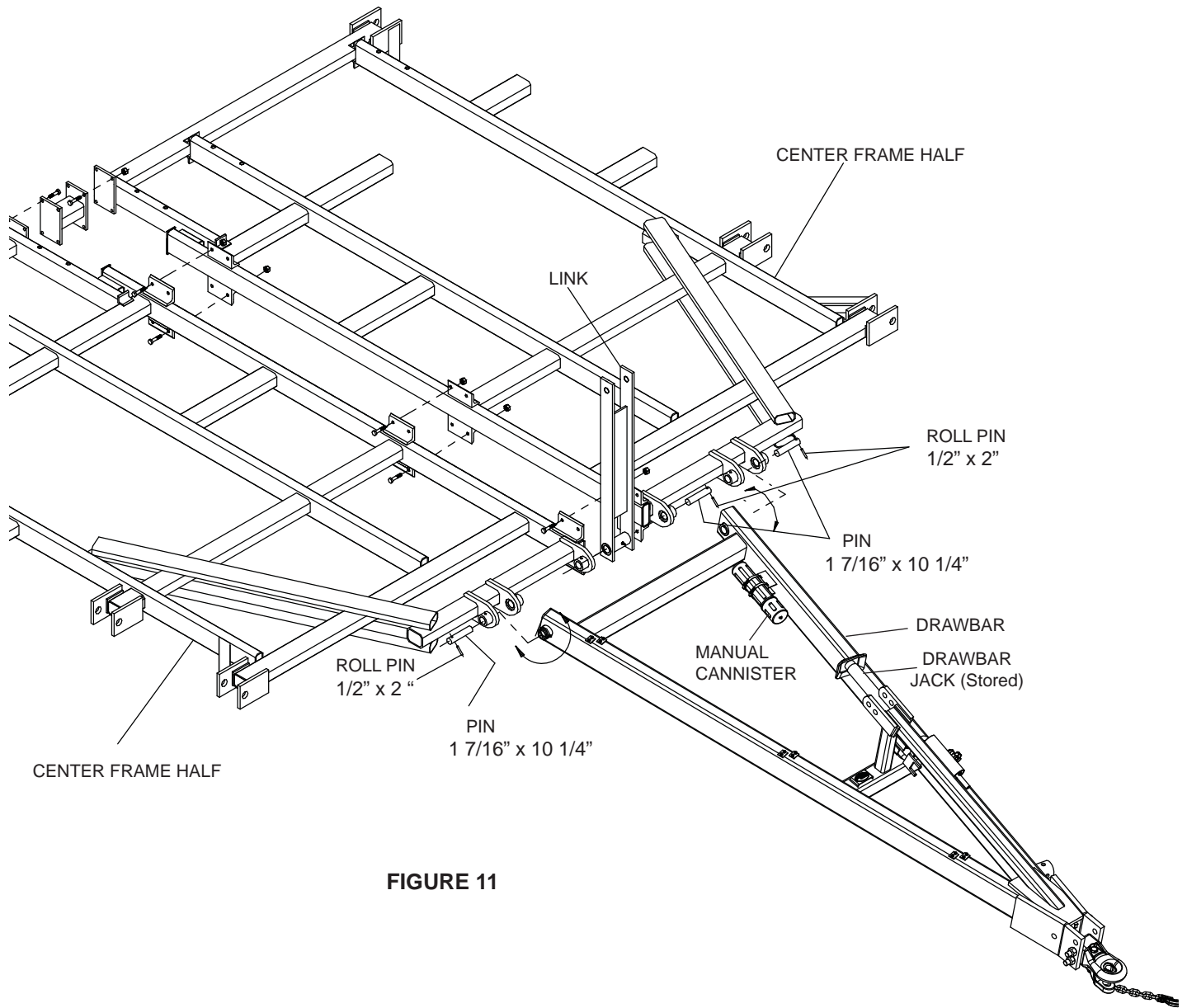

**FIGURE 11**

6. Position the sleeves of the drawbar between the lugs on the center frames. Insert the 1 7/16" x 10 1/4" pin through the lugs on the frames and through the sleeves on the drawbar. Trap each pin to the center frame lugs with one 1/2" x 2" roll pin.
7. Attach the Link between the lugs at the front center of the two center frames and secure it with the same pin and roll pin as used to attach the drawbar.

**Make sure that the drawbar is free to pivot on its pins.**

*Now tighten all hardware.*

8. *The drawbar jack can now be repositioned so that it supports the front of the drawbar.*

## ASSEMBLE THE AXLE TO THE FRAME

Do not tighten any hardware until told to do so.

1. If you did not purchase mounted tires (and tubes if desired) from Brillion, mount (4) 12.5L-15 10-Ply tires (and tubes if desired) to the 10-inch wide rims. If you purchased them from Brillion, they should be already mounted. Attach the wheel and tire assemblies to the walking beams of the center rockshaft assembly. (The wheel bolts are screwed into the wheel hubs. This is done at the factory to prevent paint from accumulating in the threads of the hubs.)
2. Place a cast iron bearing half over each of the six pairs of holes near the rear of the center frame. Temporarily hold the bearings in place by inserting a 3/4" x 14" long bolt through each of the bearing holes and extending it through the holes in the center frame tubes. Apply a generous layer of grease to the inside of these bearing halves. Lower the wheel and axle assembly onto the bearing halves.

The two bearing stops on the axle pipe will be toward the inside from the bearings. See drawing.

3. Remove the bolts from the bearing halves. Apply a generous film of grease to six more bearing halves and place these over the bearings already in place. Re-insert the 3/4" x 14" long bolts through the bearings and frame tubes and attach the 3/4" locknuts. Bolts should be inserted from the bottom up to allow for placement of hose brackets later on.

These locknuts should now be tightened securely to the bolts. Apply 125-165ft-lb torque to the nuts.

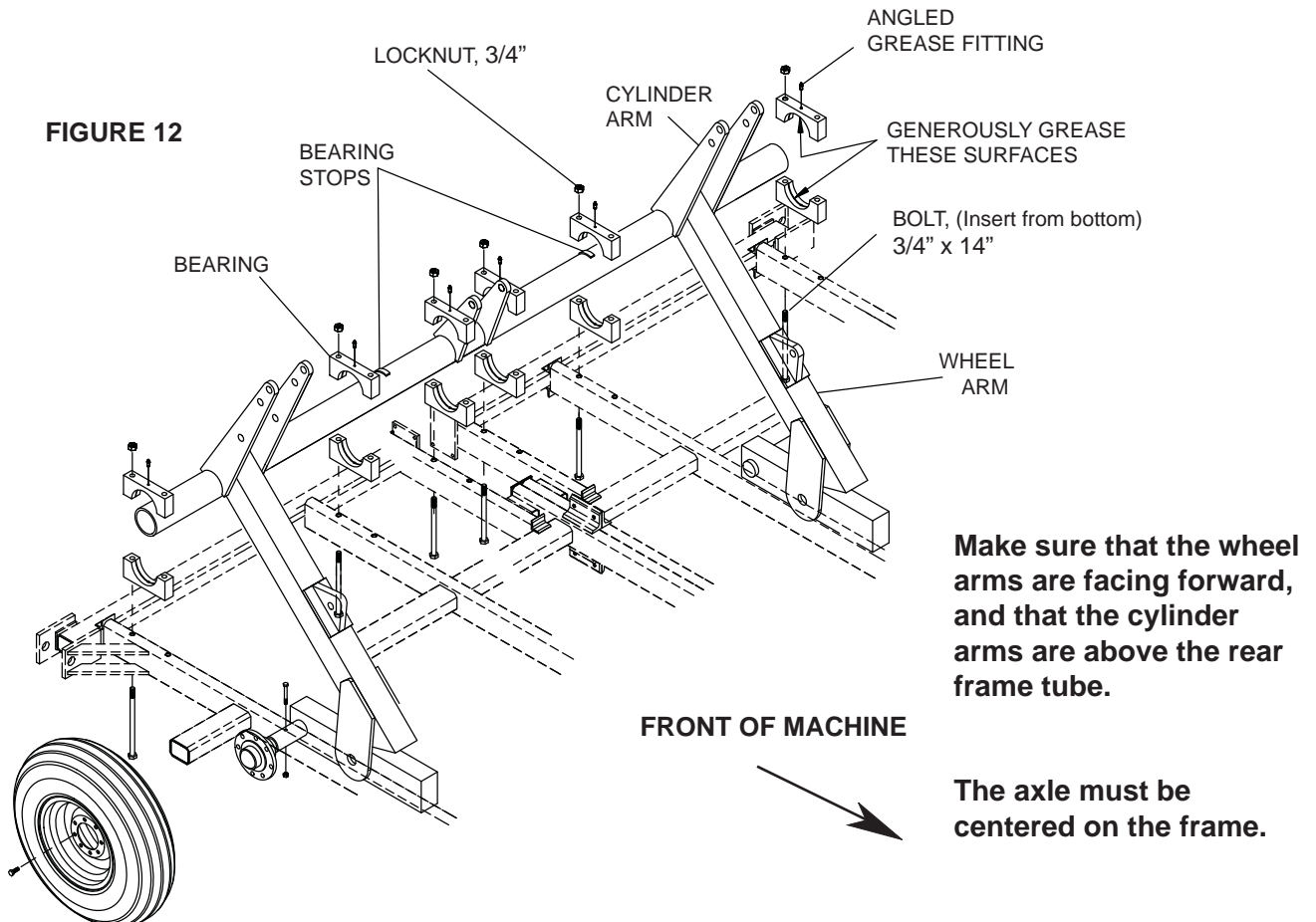

Assemble the adjust tubes as follows, noting also the additional statements on page 20a:

1. Attach a left hand screw anchor (**part #4K301**) to the left front side of the center frame and a right hand screw anchor (**part #4K302**) to the right front side of the frame. (The right hand assembly is shown below; assemble the left hand assembly in similar fashion.) Secure each anchor with two U-bolts and 5/8" locknuts. **Now tighten them securely to U-bolts. Apply 70-95 ft-lb torque to locknuts.**
2. Place two machinery bushings over the adjust screws and insert the adjust screws through the holes in the screw anchors. Assemble the depth adjust mechanism with the threaded lock plate according to the diagram on page 20a.

**FIGURE 13**

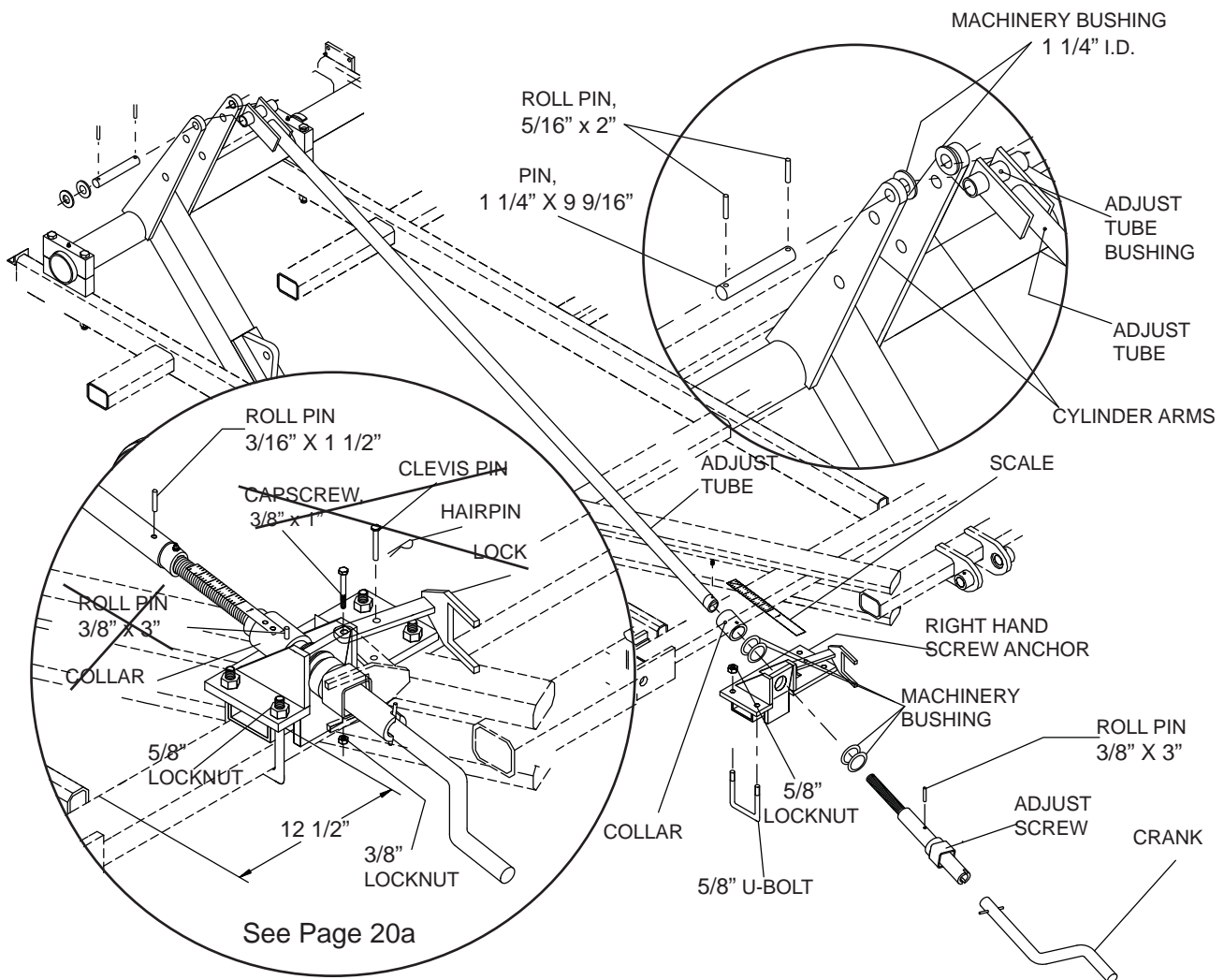

3. Place an adjust tube between each pair of cylinder arms at the top hole. Insert a 1 1/4" dia. x 9 9/16" long pin through the top hole, and then place a 1 1/4" inside diameter machinery bushing over the pin. Extend the pin through the bushing on the adjust tube, and place another machinery bushing over the pin before extending it through the other cylinder arm. Hold it in place with two 5/16" x 2" long roll pins.

**SPECIAL DEPTH ADJUST MECHANISM ASSEMBLY -  
CENTER SECTION HFC32 & LARGER**

It has been determined that use of certain components could contribute to damage to the axle tube.

Therefore, on the CENTER SECTION ONLY, when assembling the depth adjust mechanism (HFC 32 through HFC 45),

- Do not use:   The 2 3/4" O.D. Collar.  
                   The 3/8" Roll Pin.  
                   The 2 Machinery Bushings located above the Depth Control Anchor.  
                   The locking mechanism as previously shown in figure 13 on Page 20.

- Do include:   The 2" square threaded lock plate as shown below.

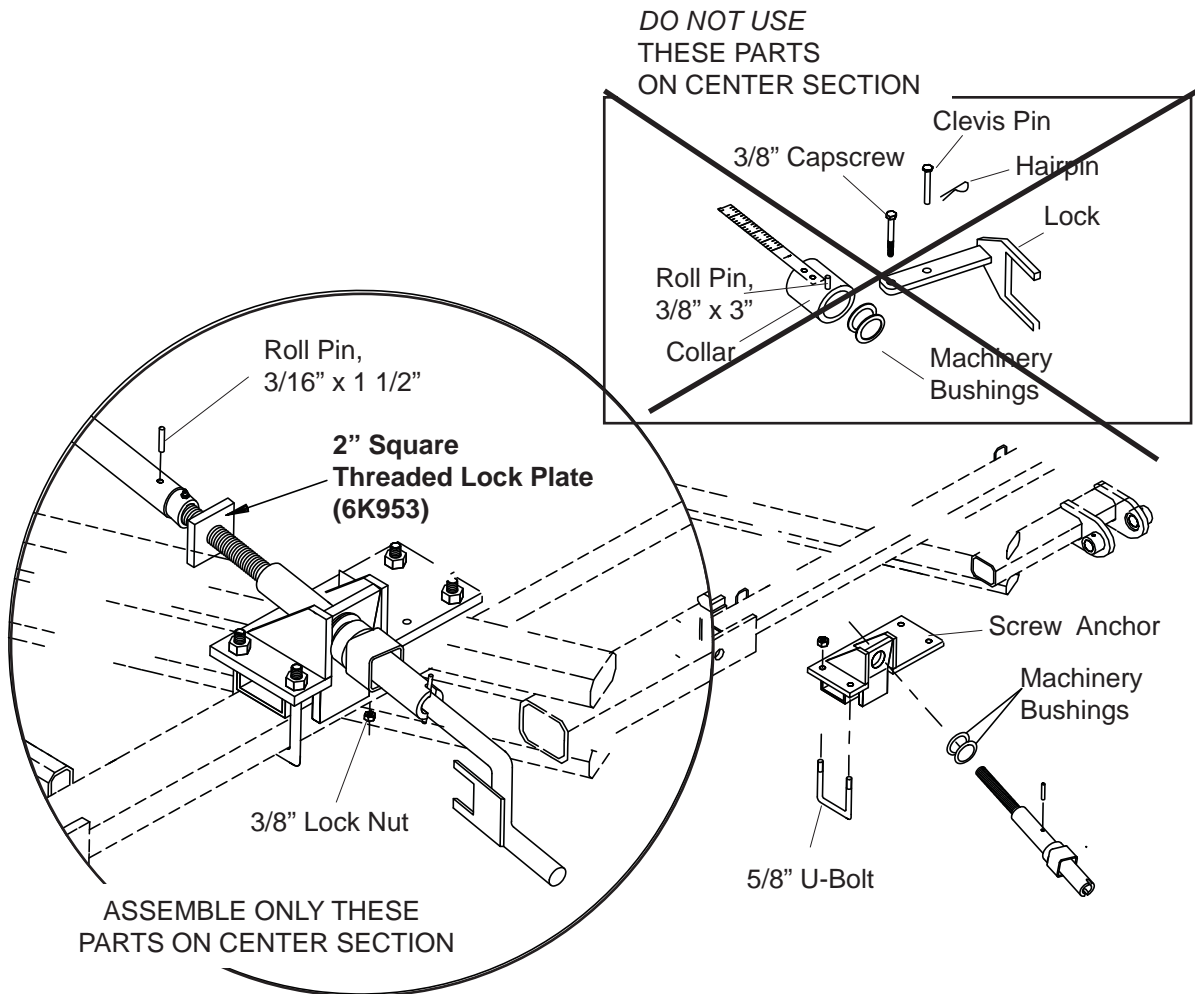

The depth adjust mechanism on the wing sections are assembled according to normal instructions.

- Thread the adjust screw into the adjust tube. When the hole in the threaded portion of the adjust screw aligns with the hole in the adjust tube, insert a 3/16" x 1 1/2" roll pin through the access hole in the adjust tube into the hole in the screw.



**NOTE:** This roll pin is to keep the assembly from coming apart during adjustment. Failure to install the roll pin could result in damage to the machine and possible injury to the operator.

- Attach the lock to the angle on the screw anchor with 3/8 x 1" capscrew and locknut, and finish by attaching a scale to each of the collars which were placed over the adjust tube. Use two of the self tapping screws found in the cloth bag. Since this screw adjust rod is located on the *center section*, use the collar holes which are *farthest* from the roll pin for attaching the scale. (The different holes compensate for the fact that larger tires are used on the center section than on the wings).

**The hydraulic circuit which controls the gage wheel uses a pair of series hydraulic cylinders. This means that it is extremely important to install the cylinders exactly as directed.**

- Attach one cylinder with the number **2K093** stamped on it to each of the cylinder anchors of the center axle assembly. *Make sure to install it with the ports facing the rear.* Extend a 1" x 9 1/2" bolt through one of the cylinder arms, then through the clevis lugs on the butt end of the cylinder, and out through the other cylinder arms. Secure the bolt with a 1" locknut. ***These nuts can be tightened, but do not turn them so tightly that they cause the cylinder arms to bind against the sleeve of the adjust tubes.***
- Attach the rod end of the clevis of each cylinder and a transport lock to the cylinder lugs on the center axle wheel arms. Use 1" diameter x 5 1/16" long pins. Secure the pins with 1/4" diameter x 2" long roll pins.

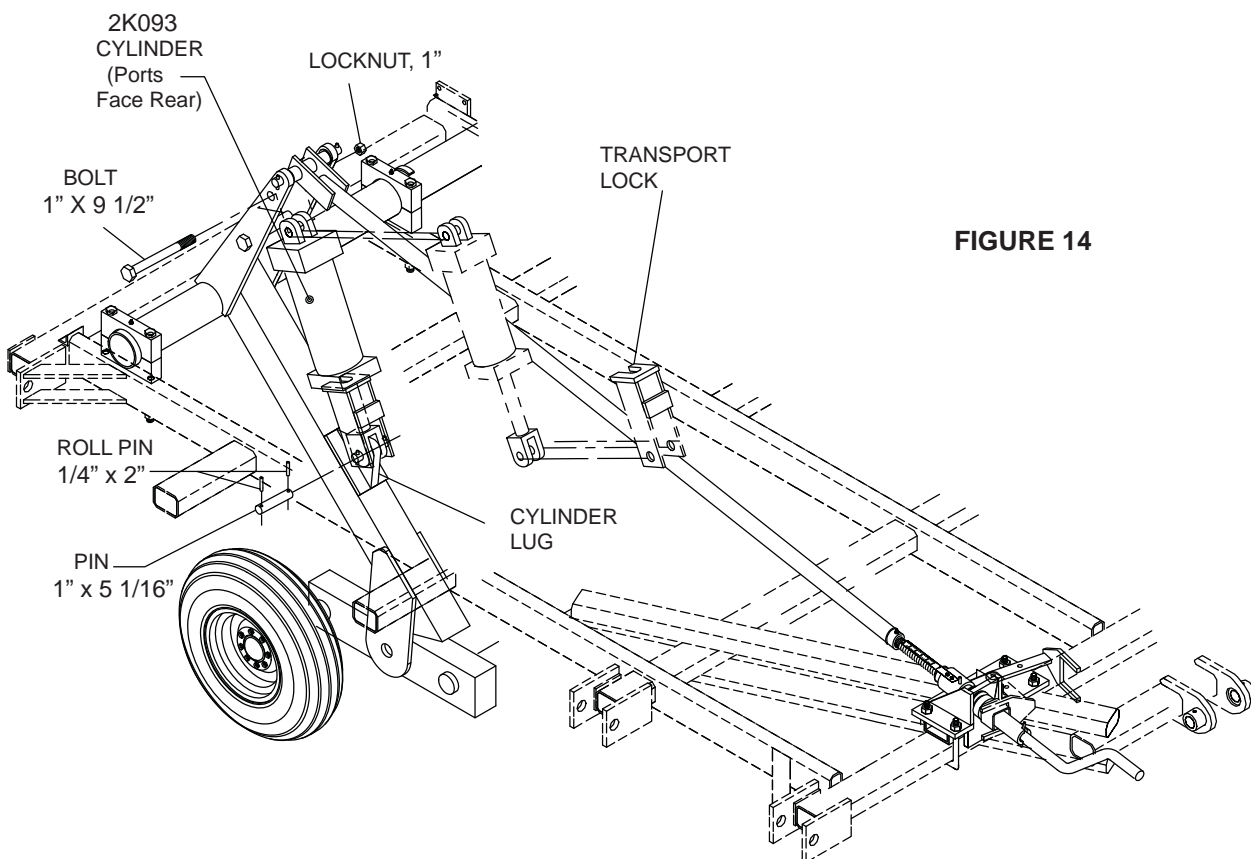
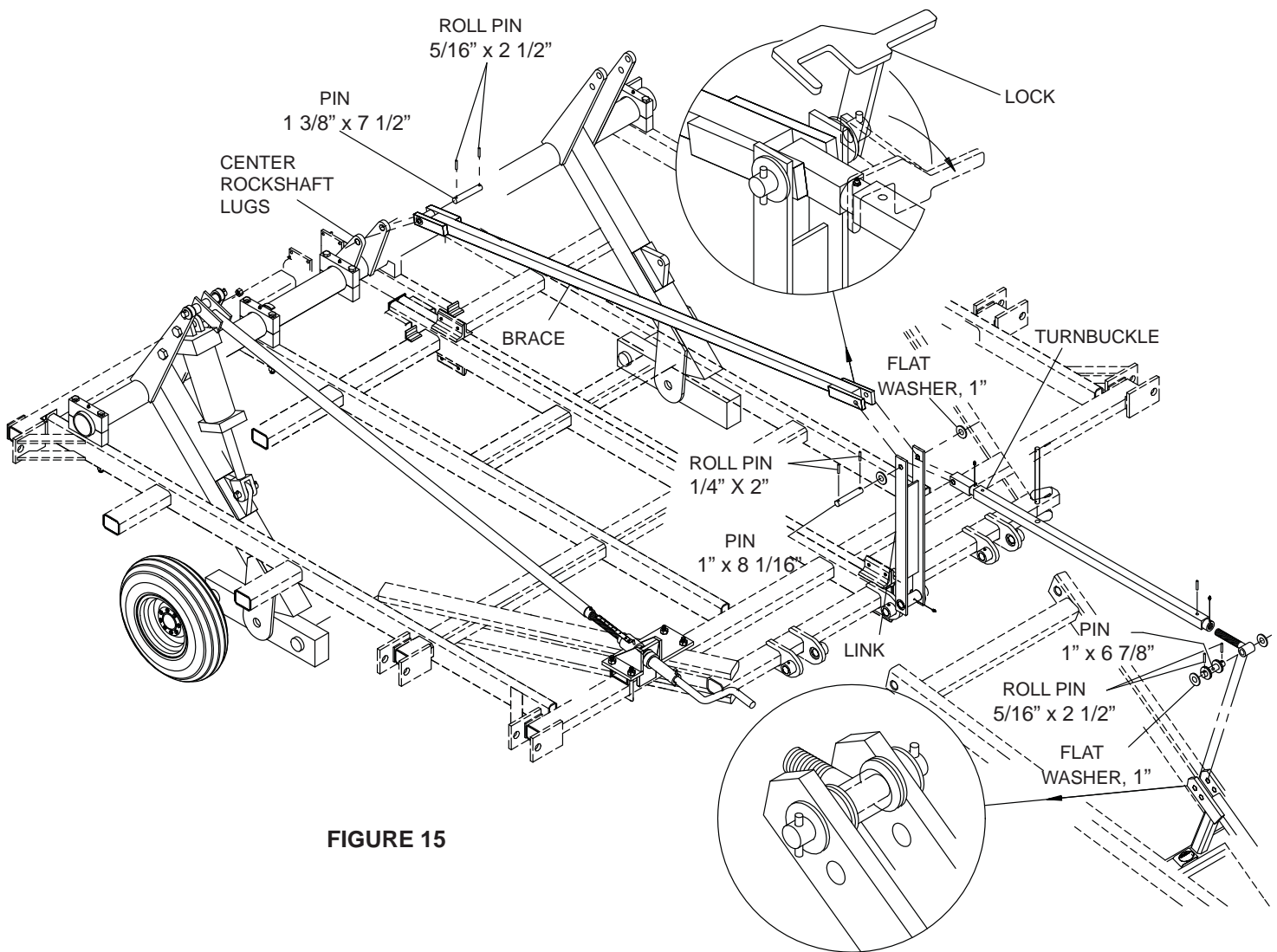

**FIGURE 14**



## ATTACH THE BRACE AND TURNBUCKLE BETWEEN THE ROCKSHAFT AND THE DRAWBAR

1. Place the sleeve of the 4K309 brace between the two lugs at the center of the rockshaft. Use the 1 3/8" diameter x 7 1/2" long pin to fasten the brace to the rockshaft. Secure the pin with two 5/16" x 2 1/2" long roll pins.
2. Connect the brace to the link which is pinned to the front of the center frames and to the block end of the drawbar adjust turnbuckle. The link straddles the brace which, in turn, straddles the block end of the turnbuckle. The three, along with the lock, are joined with a 1" x 8 1/16" long pin which is trapped with two 1/4" x 2" long roll pins.
3. The sleeve end of the turnbuckle is attached to one of the two holes of the drawbar. Use the 1" x 5 1/2" long pin to join the two. Secure the pin with two 5/16" x 2 1/2" long roll pins.



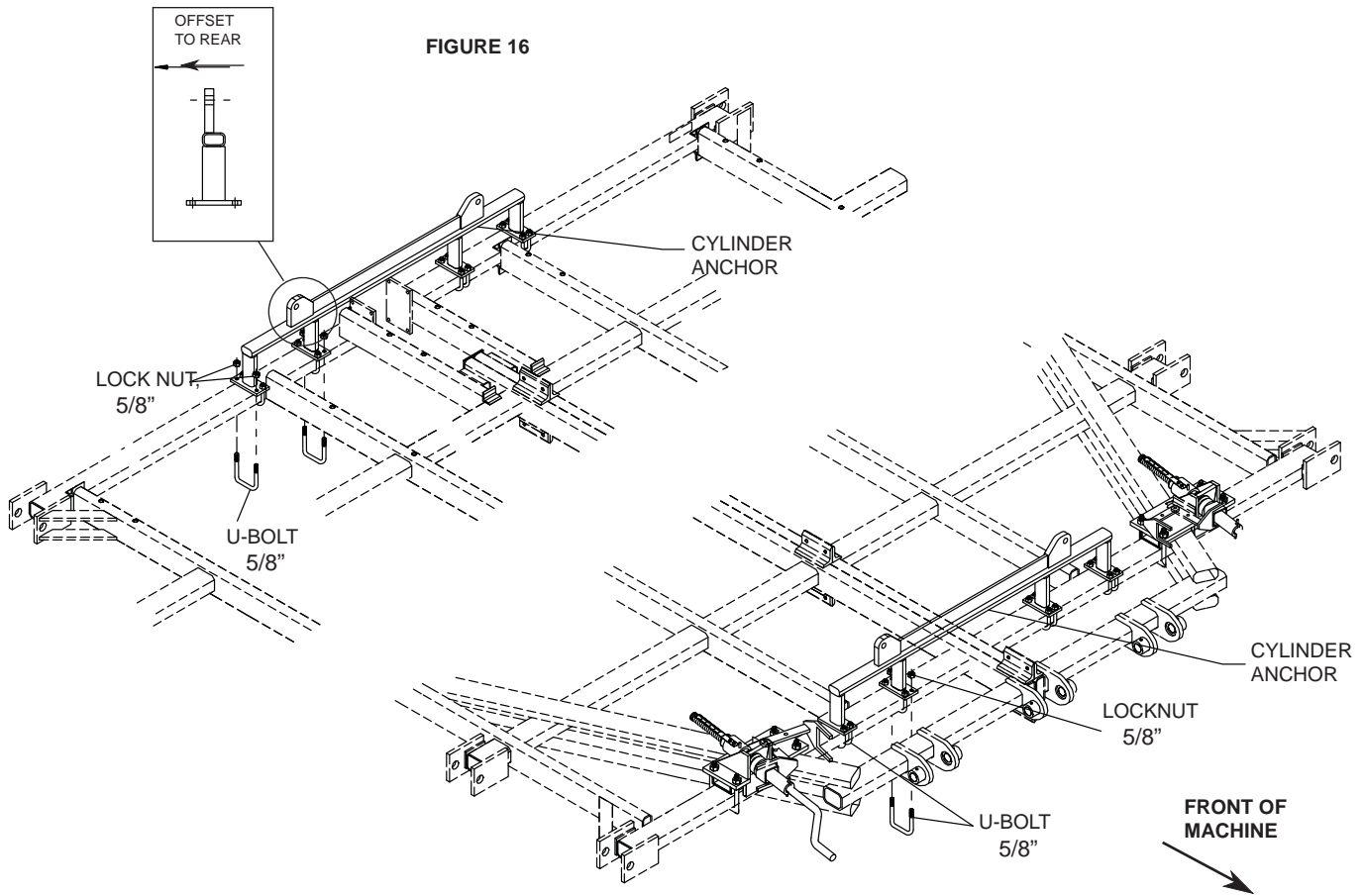

### ATTACH CYLINDER ANCHOR TO THE CENTER FRAME

1. Center a cylinder anchor over the front and rear toothbars of the center frames.  
**The cylinder anchors are not symmetric and must be mounted with the cylinder mounting lug offset to the REAR of the cultivator.**
2. Fasten each cylinder anchor with eight U-bolts, securing the U-bolts with 5/8" locknuts. ***Torque the locknuts to 70-95 ft-lb.***  
 (The cylinder anchors act as trusses to stiffen the center frame. Therefore it is important that all the U-bolts are used and all the locknuts are tightened securely.)

## ATTACH THE WINGS TO THE CENTER FRAME

**Adjust the center frame so that it is horizontal.**

**Attach the wing sections as instructed to keep the assembly balanced.**

Each wing consists of a front half, a rear half, and an outer wing.

1. Approximately align the hinge sleeves of the front and rear wing halves and bolt the front halves LOOSELY to the rear halves. Extend U-bolts around the rear tube of the front wing halves and through the holes in the plates on the front of the rear wing halves. Turn 5/8" locknuts loosely onto each U-bolt.
2. Now, position the hinge sleeves of the wings between the hinge plates on the center section. Install hinge pins through each set of hinges and secure the hinge pins with 5/16" x 2 1/2" long roll pins.
3. Next align the outer wing so that its hinge plates are inside those of the mating plates of the front and rear wing halves. Install 4K326 hinge pins through front and rear plates, and 4K906 hinge pin *from back to front* through interior plates. **Be sure that the tab on this pin is toward the rear for later hydraulics assembly.**
4. At the rear, install the lift arms for the cylinder by positioning them inside the two sets of hinge plates as shown in figure 17. Placing the 1 1/4" x 2 3/8" sleeve between the arms to hold them apart, insert a 1 1/4" x 6 13/16" pin through the hole near the bottom of the plates and trap with 1 1/4" flat washers and 5/16" roll pins. **With the hinge pins installed and the wings level with the center section, TIGHTEN THE NUTS ON THE U-BOLTS TO 70-95 FOOT POUNDS TORQUE.**
5. Attach the wing stands on the wing tube shown with two U-bolts and locknuts. On machines using the smaller outer wing (two frame tubes extending front to back) attach at 33 3/8" left & right from the hinge

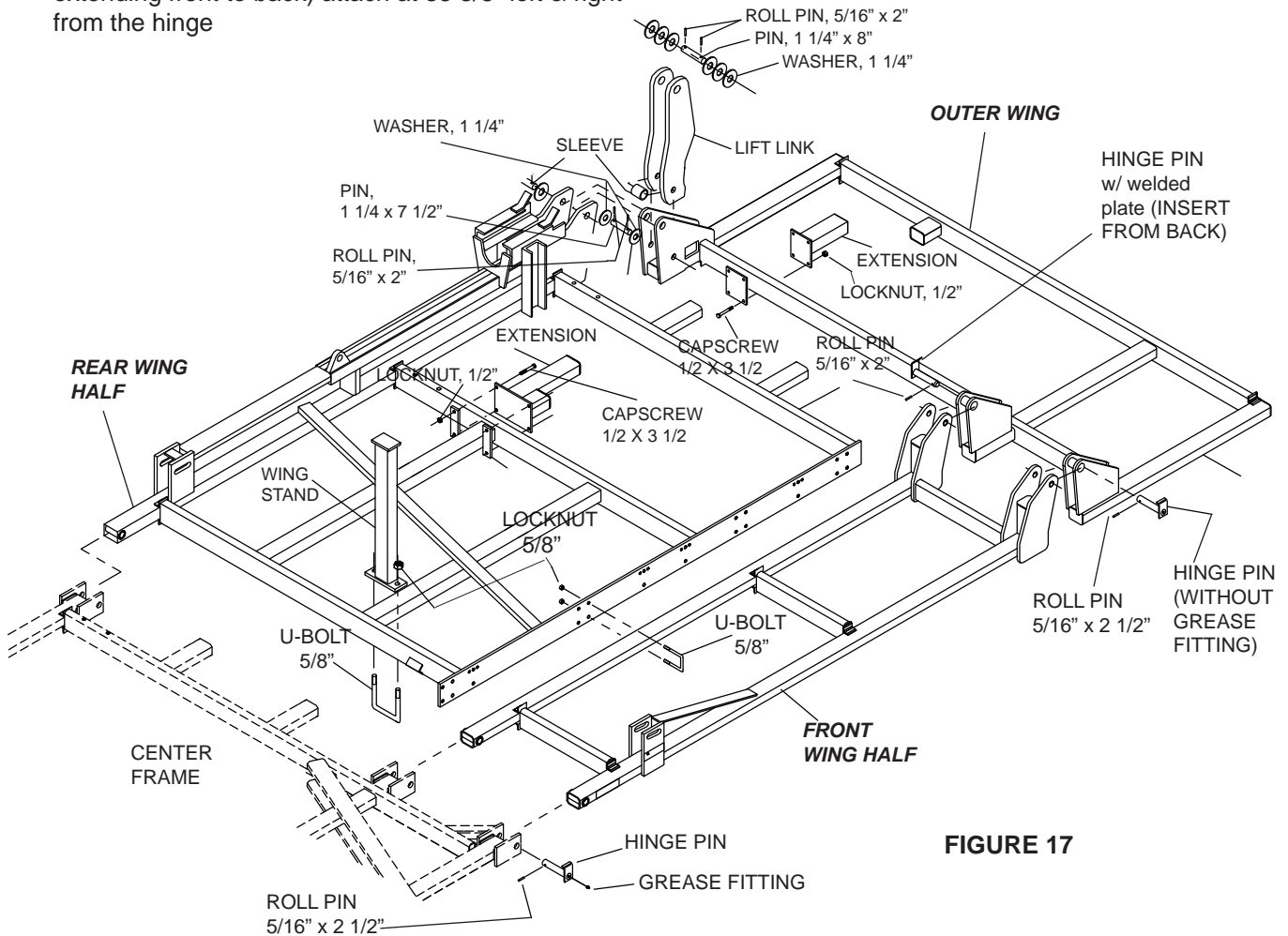

**FIGURE 17**

## ATTACH CYLINDERS TO THE CYLINDER ANCHORS

1. Connect the clevis ends of the four 4" x 30" long hydraulic cylinders to the cylinder anchors on the machine center. Position the cylinders with the ports facing the back of the machine as shown in the drawing below. Use the pins packaged with the cylinders to attach the cylinders to the anchors.
2. Use 1" x 6" long pins to attach the rod end clevis of each cylinder between the lugs on the wings. Flat washers 1" in diameter are used to center the clevis between the lugs. 1" diameter flat washers are also used outside of the lugs. The pins are held in place with 5/16" x 2 1/2" long roll pins.
3. Mount the clevis ends of the two 4" x 24" cylinders to the lugs on the hinge weldments of the rear half of the inner wing (ports facing rearward), again fastening with the pins packaged with the cylinders.
4. Extend the rod between the lift arms on the outer wing. Insert a 1 1/4" x 8 7/16" pin through the lift arms and cylinder rod end. Place three 1 1/4" washers and a roller assembly on the pin outside of each lift arm, then a machinery bushing, and trap with 5/16" x 2 1/2" roll pins. See figures 17 & 18.

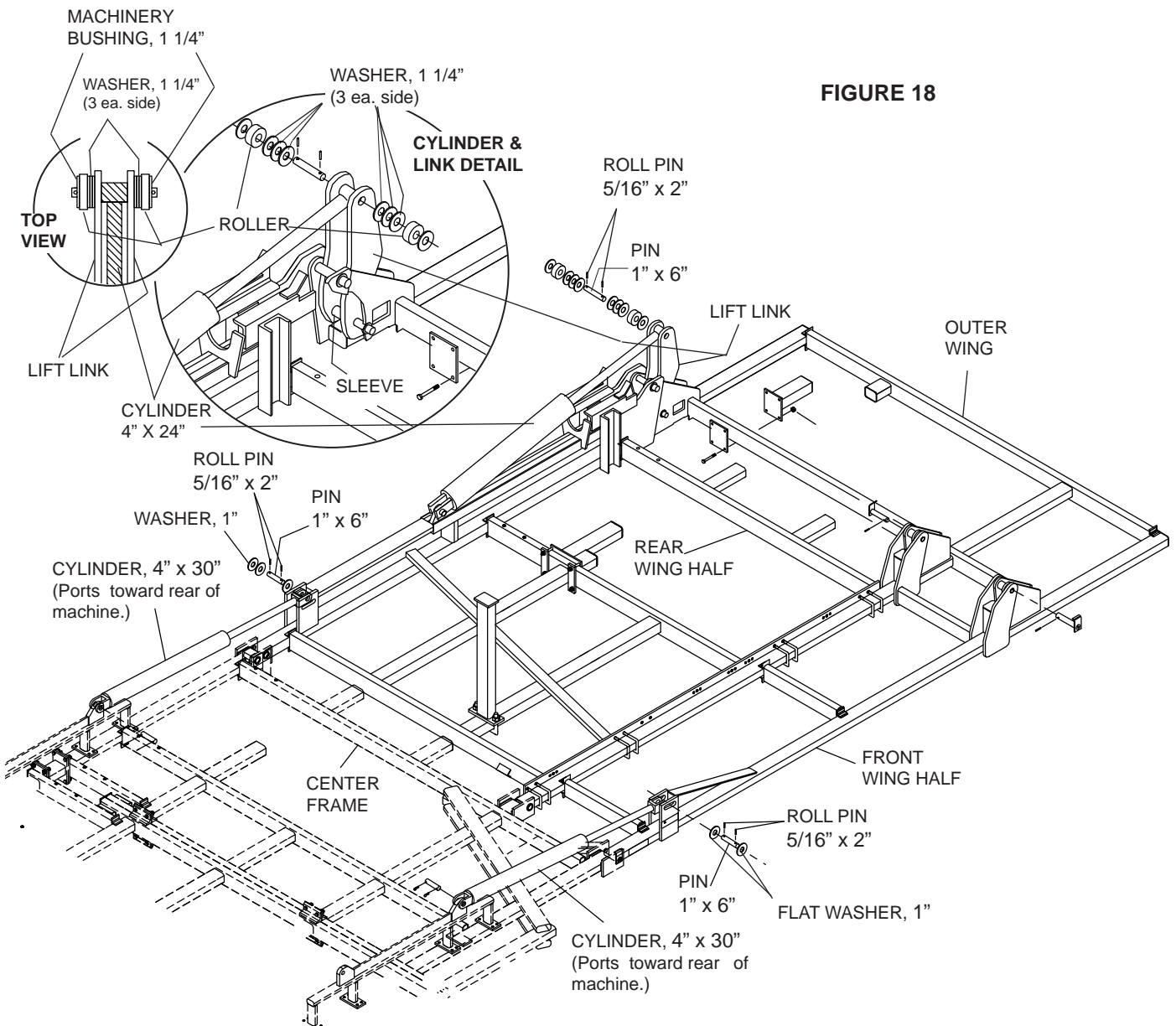

## MOUNT THE WING GAGE WHEELS TO EACH WING

*Do not tighten any hardware until told to do so.*

1. If not already mounted, mount (4) 9.5L-15 6-Ply tires to 8" wide rims, then attach them to the walk ing beams of each wing rockshaft assembly. (This step is not shown in the drawing below. See center rockshaft drawing if needed.)
2. Place a cast iron bearing half over each of the two pairs of holes near the outside rear of each wing. Temporarily hold the bearings in place by inserting a 3/4" x 14" long bolt through each of the bearing holes and extending it through the holes in the wing frame tubes. Apply a generous layer of grease to the inside of these bearing halves. Lower the wheel and axle assembly onto the bearing halves.

**The left and right wing rockshafts are identified by the dimensions shown in the drawing. 4K241 is the left axle assembly and 4K242 is the right axle assembly.**

*Make sure that the wheel arms are facing forward and the cylinder arms are above the rear frame tube as shown. The two bearing stops on the axle pipe will be inside from the bearings.*

3. Remove the bolts from the bearing halves. Apply a generous film of grease to four more bearing halves and place these over the bearings already in place. Re-insert the 3/4" x 14" long bolts through the bearings and frame tubes and attach the 3/4" locknuts.

*These locknuts should now be tightened securely to the bolts. Apply 125-160 ft-lb torque to the nuts.*

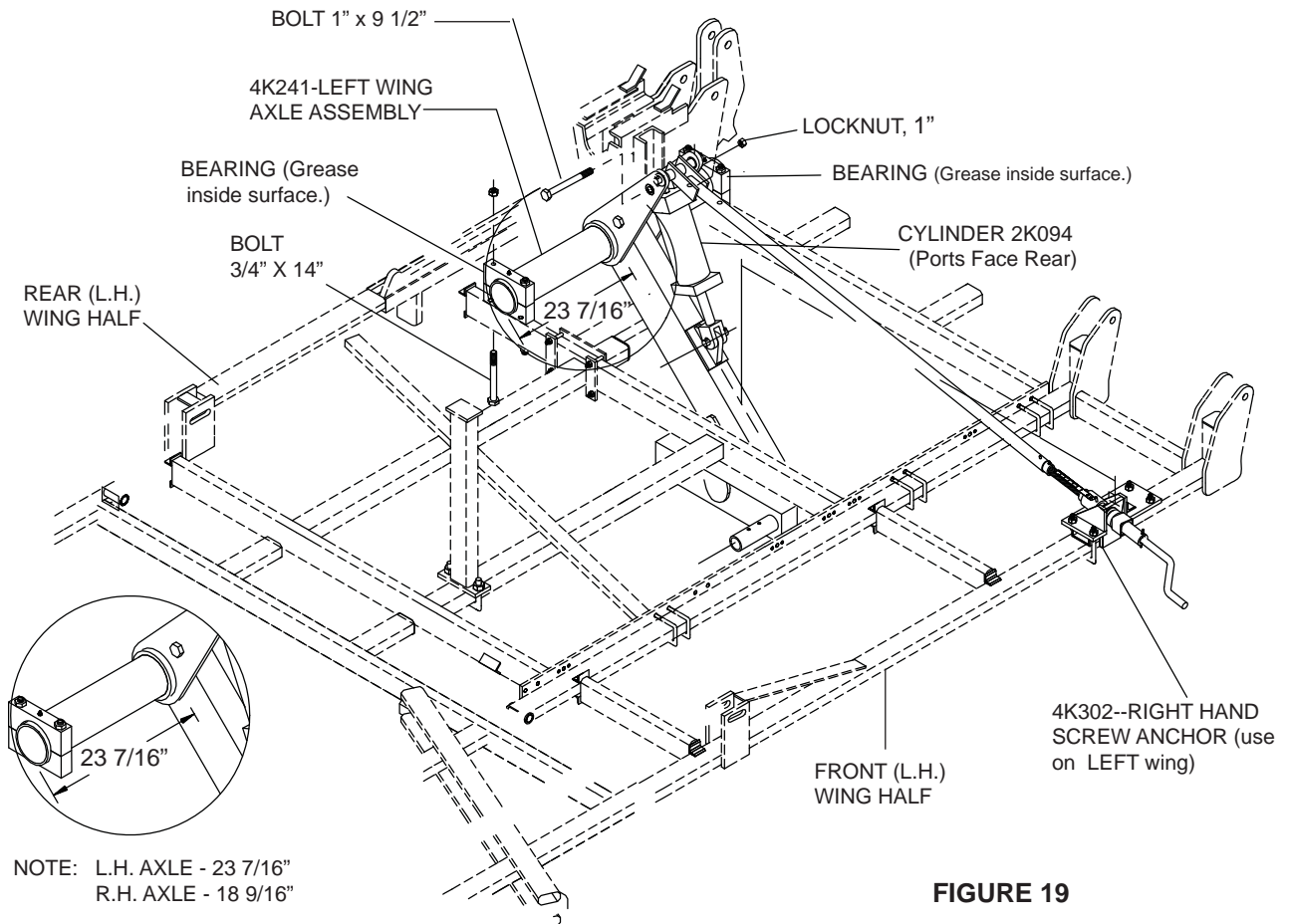
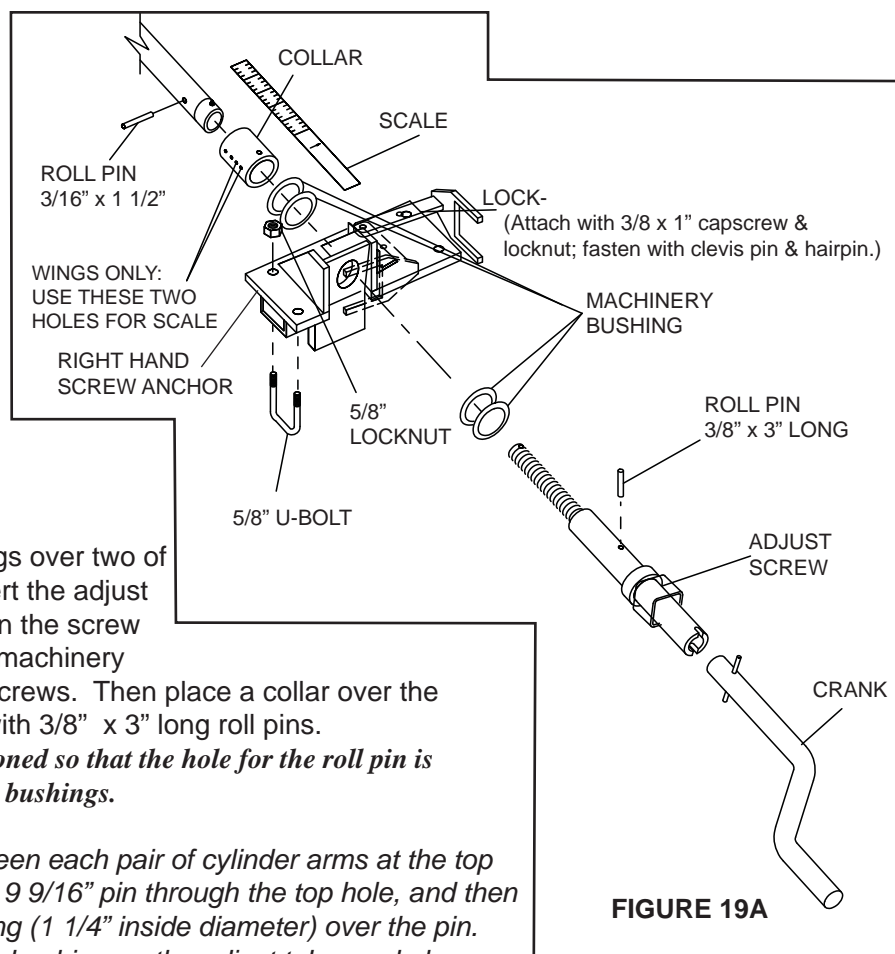

**FIGURE 19**

The screw anchors and adjust tubes of the wings are assembled in the same manner as on the center frame **EXCEPT**:

1. The screw anchors are used on opposite sides.
2. A different hole is used when putting the scale on the collar.
3. The items not used in the center are used in the wing sections.

1. Attach a **RIGHT HAND** screw anchor (part #4K302) to the *left wing frame* and a **LEFT HAND** screw anchor (part #4K301) to the *right wing frame*. Locate them as shown in Figure 19 on the previous page, and secure each anchor with two U-bolts and 5/8" locknuts. See also Figure 13, if needed.



2. Place 2 machinery bushings over two of the adjust screws and insert the adjust screws through the holes in the screw anchors. Place two more machinery bushings over the adjust screws. Then place a collar over the adjust screw and secure with 3/8" x 3" long roll pins.  
*Note: Collars must be positioned so that the hole for the roll pin is nearest the machinery bushings.*

3. Place an adjust tube between each pair of cylinder arms at the top hole. Insert a 1 1/4" dia. x 9 9/16" pin through the top hole, and then place a machinery bushing (1 1/4" inside diameter) over the pin. Extend the pin through the bushing on the adjust tube, and place another machinery bushing over the pin before extending it through the other cylinder arm. Hold in place with two 5/16" x 2" roll pins.

4. Thread the adjust screw into the adjust tube. When the hole in the threaded portion of the adjust screw aligns with the hole in the adjust tube, insert a 3/16" x 1 1/2" roll pin through the access hole in the adjust tube into the hole in the screw.



**NOTE: This roll pin is to keep the assembly from coming apart during adjustment. Failure to install the roll pin could result in damage to the machine and possible injury to the operator.**

5. Attach a lock using 3/8 x 1 " capscrew & locknut, and finish by attaching a scale to each of the collars which were placed over the adjust tube. Use two of the self tapping screws found in the cloth bag. *Since this screw adjust is located on the wing, this time use the two holes which are nearest the roll pin for attaching the scale.* (The different holes compensate for the fact that smaller tires are used on the wings than on the center section.)

The hydraulic circuit which controls the gage wheel uses a pair of series hydraulic cylinders. This means that it is extremely important to install the cylinders exactly as directed.

- Attach one cylinder with the number **2K094** stamped on it to each of the cylinder anchors of each wing axle assembly. (See Fig. 19) *Make sure that the ports of the cylinder face the rear.* Extend a 1" x 9 1/2" bolt through one of the cylinder arms, then through the clevis lugs on the butt end of the cylinder, and out through the other cylinder arms. Secure the bolt with a 1" locknut.

***These nuts can be tightened, but do not turn them so tightly that they cause the cylinder arms to bind against the sleeve of the adjust tubes.***

- Attach the rod end of the clevis of each cylinder to the cylinder lugs on the wing axle wheel arms. Use the pins and cotter pins packaged with the cylinders to attach the clevis to the wheel arms.

**The smaller (two frame tubes front to back) outer wing assemblies have only a single wheel.**

Otherwise, using the 4" x 8" cylinders, assemble the axle assemblies to the outer wings in the same manner as the inner wings, making sure to use a right hand screw anchor on the left wing and a left hand screw anchor on the right wing as you did on the inner wings, and keeping the hole of the screw anchor in line with the center of the wheel arm.

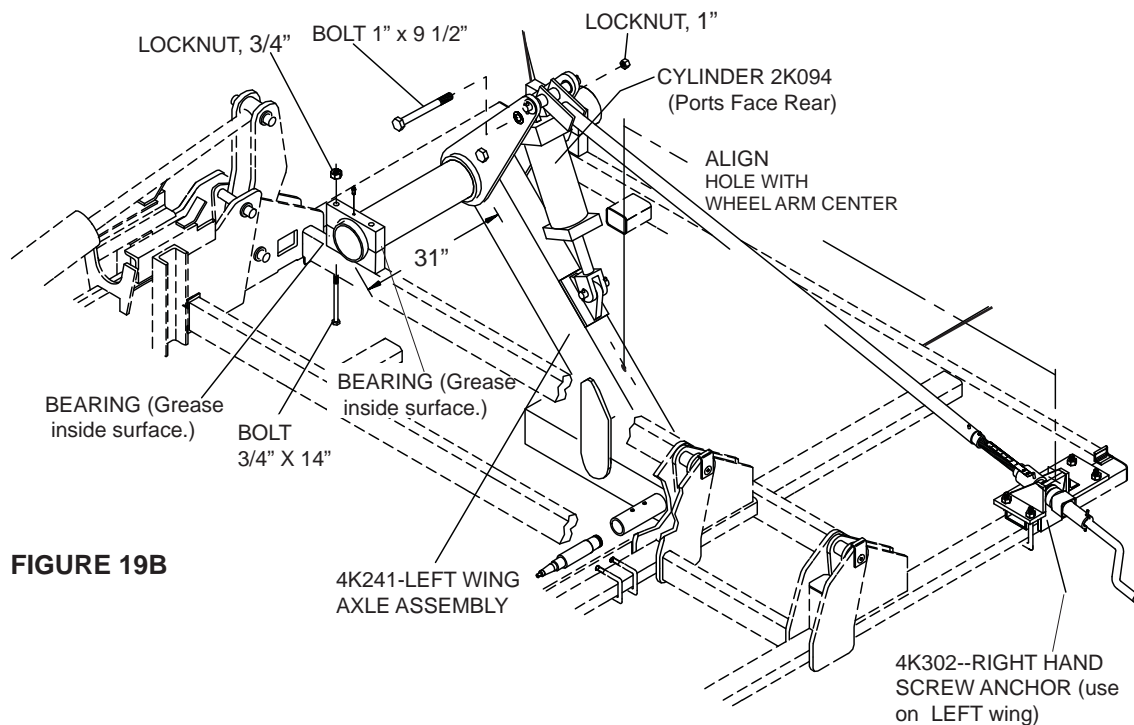

## MOUNT THE GAGE WHEEL ONTO THE FRONT WING

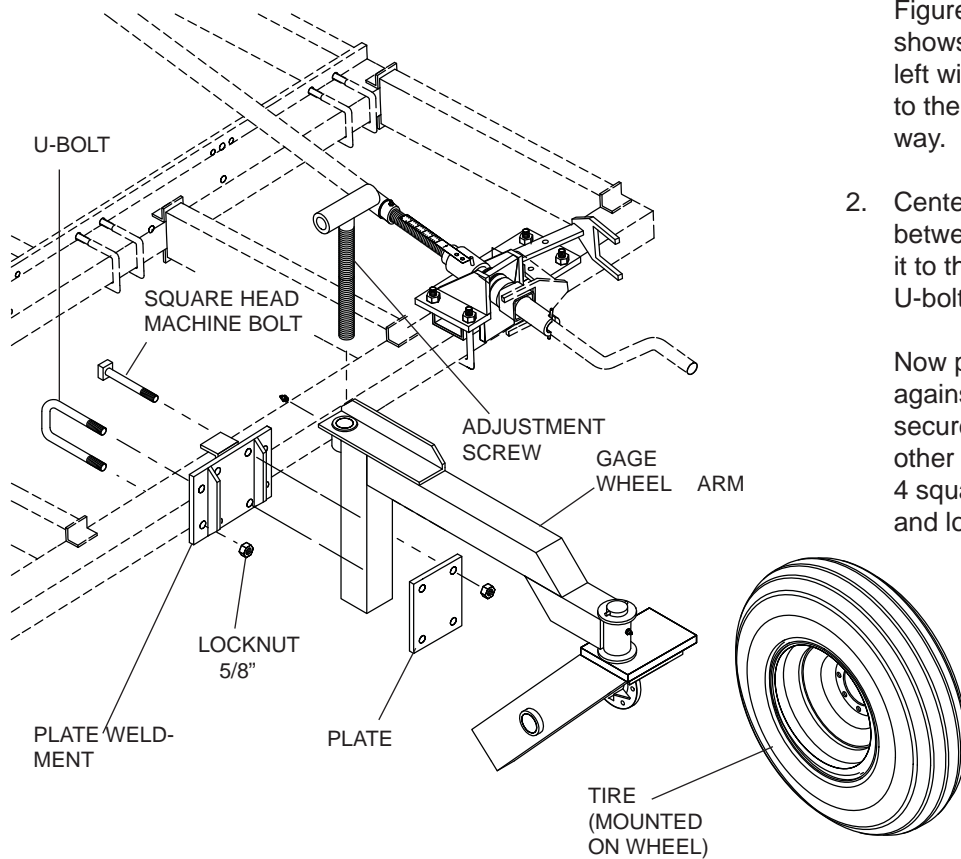

**FIGURE 20**

1. Mount the gage wheel arms to the front wings as shown in Figure 20. The illustration shows the assembly for the left wing; mount the assembly to the right wing in the same way.
2. Center the plate weldment between two shanks and mount it to the wing using two 5/8" U-bolts and locknuts.

Now place the gage wheel arm against the plate weldment and secure it to the wing with the other plate, fastening it with 4 square headed machine bolts and locknuts.

3. Thread the adjustment screw into place.
4. Mount the wheel and tire onto the hub and spindle assembly.



## SHANKS

Assemble the sweeps or points to the shanks before mounting the shanks.

**Note:** The field cultivator is designed for using 9" wide sweeps, if wider sweeps are used, be sure to check clearances around all tires in both the operating and transport positions.

### 6K262 - QUICK-CHANGE POINTS

Assemble the Quick-Change Point Assembly as shown in the illustration:

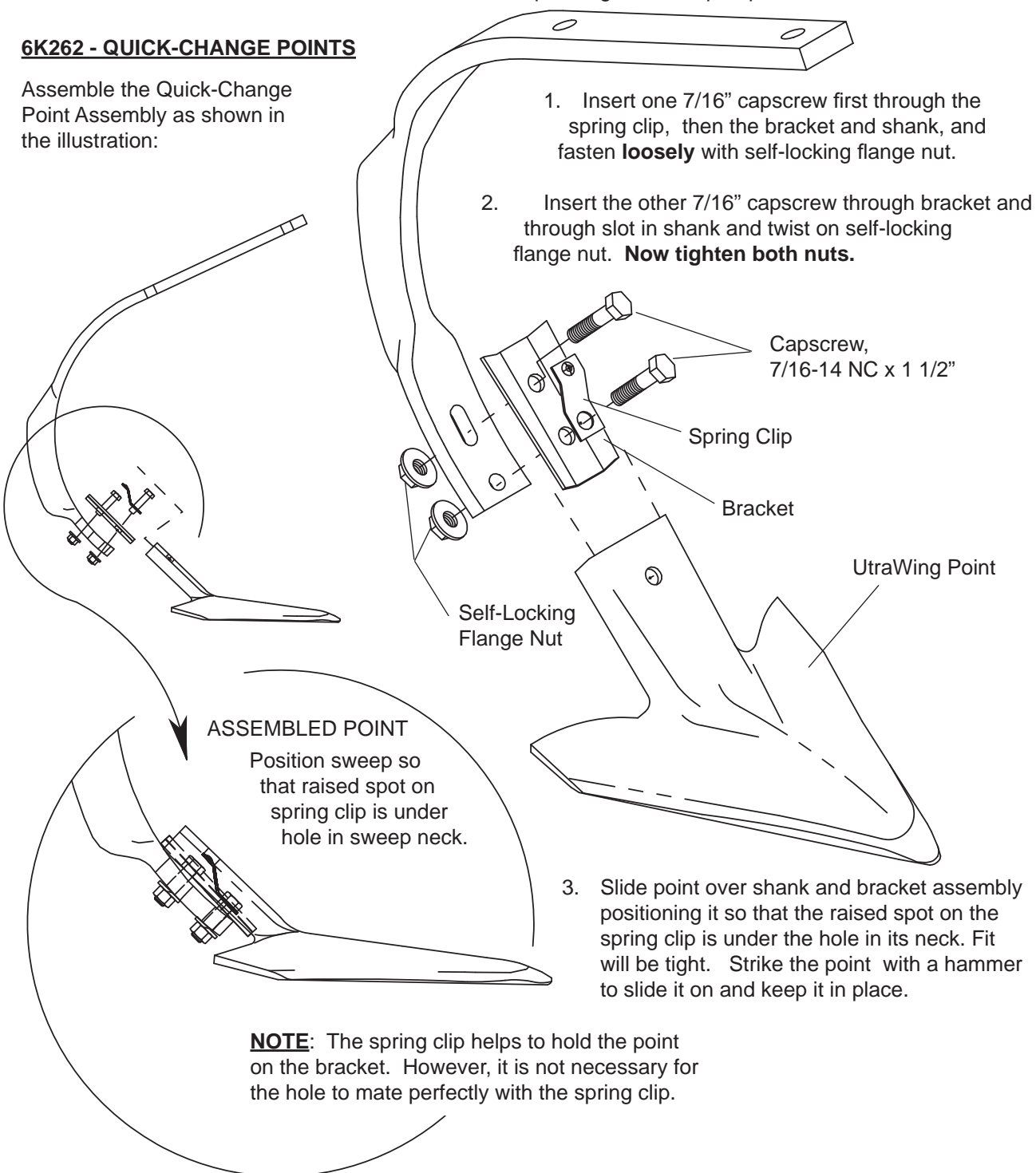

**Use the drawings and diagrams on the following pages for correct shank placement and mounting procedure.**

Hardware for mounting the spring loaded shanks is attached to each shank assembly  
Hardware for mounting the 2-piece S-tines is packaged in separate box assemblies.

**Spring Loaded Shanks:**

To mount the spring loaded shank on your Field Cultivator, use the following procedure:

1. Remove the tensioning bolt from the spring assembly
2. Rotate the spring out of the spring holder bracket.
3. Remove the nuts from the U-bolt, and then also remove the U-bolt.
4. Position the shank assembly at the desired location on the cultivator frame.
5. Insert the U-bolt around the frame tube, and install the two nuts back onto the U-bolt.

6. **Tighten the tensioning bolt making sure that a gap of 1 5/8" remains between the spring holder and the plug in the end of the spring. *The 1 5/8" gap dimension is critical to obtain correct point pressure and to prevent possible damage to the spring.* (Refer to the drawing below.)**

**2-Piece S-Tine Shanks:**

The 2-piece S-Tine shank is shipped pre-assembled from the factory. For mounting use the clamp and clip assembly shown below to fasten the shanks at the positions indicated for your model. Follow the diagram on pages 32 and 33 for correct placement. Use the offset bracket shown below to place shanks behind the large hinge weldments where the inner wing joins the outer wing.

To mount shanks at the hinge site of the outer wings, use the strap and hardware shown below; or where a plate backs a tube, use method and hardware described on the following page.

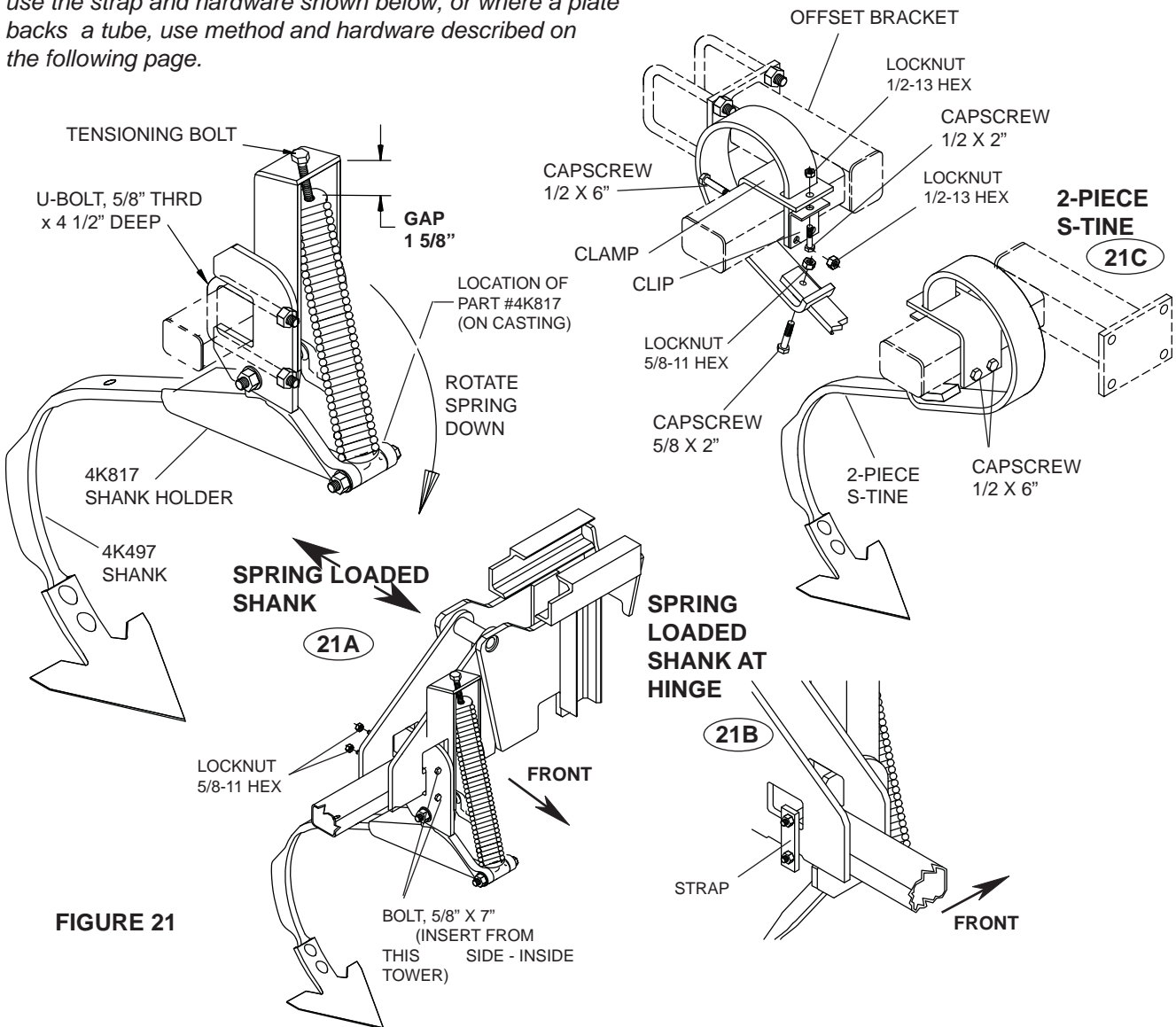

**FIGURE 21**

## MOUNTING SHANKS WHERE A PLATE BACKS A TUBE

### METHOD OF MOUNTING SHANKS AT SECOND RANK OF EACH WING

FOLLOW THE NORMAL PROCEDURE FOR MOUNTING THE SPRING LOADED SHANK BUT USE THE TOW BOLTS IN PLACE OF THE U-BOLTS

TO MOUNT THE 2-PIECE S-TINE SHANK, USE THE PLATES. STRAPS AND BOLTS IN PLACE OF THE CLAMP, CLIP AND U-BOLTS.

TWO 5/8" x 6" BOLTS & LOCKNUTS (INSERT BOLTS AS SHOWN WITH HEADS INSIDE TOWER)

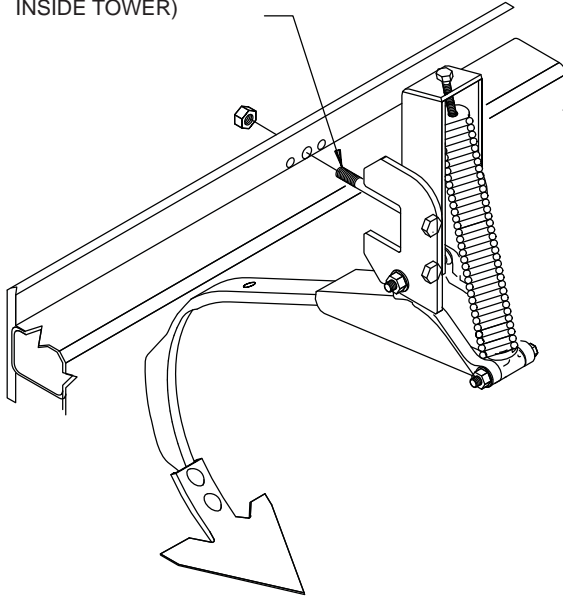
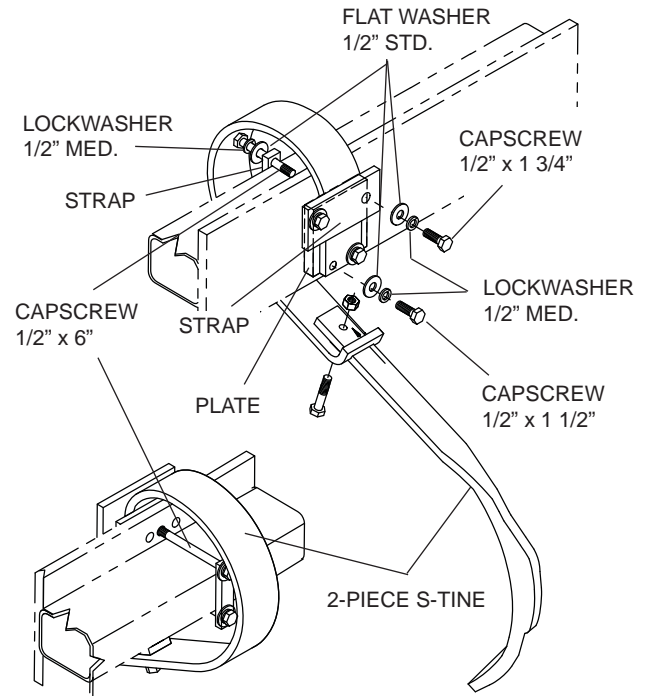
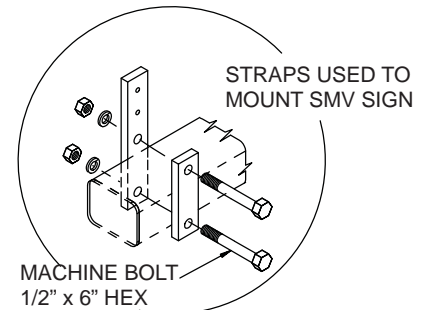

FIGURE 22



A strap is provided which has two holes for mounting a Slow Moving Vehicle (SMV) bracket. Use this strap with the SMV strap and bolts provided in the hardware box assembly. Locate the SMV bracket as close to the center of the machine as possible.



# SHANK LOCATION for Models equipped with SMALL OUTER WING

	#4K504 short extensions used	#4K504 short extensions used
37'	2	4
38'	2	4
39'	2	4
40'	4	4

**(40')** ← Outermost Shank For Each Size Machine  
Shown in This Way

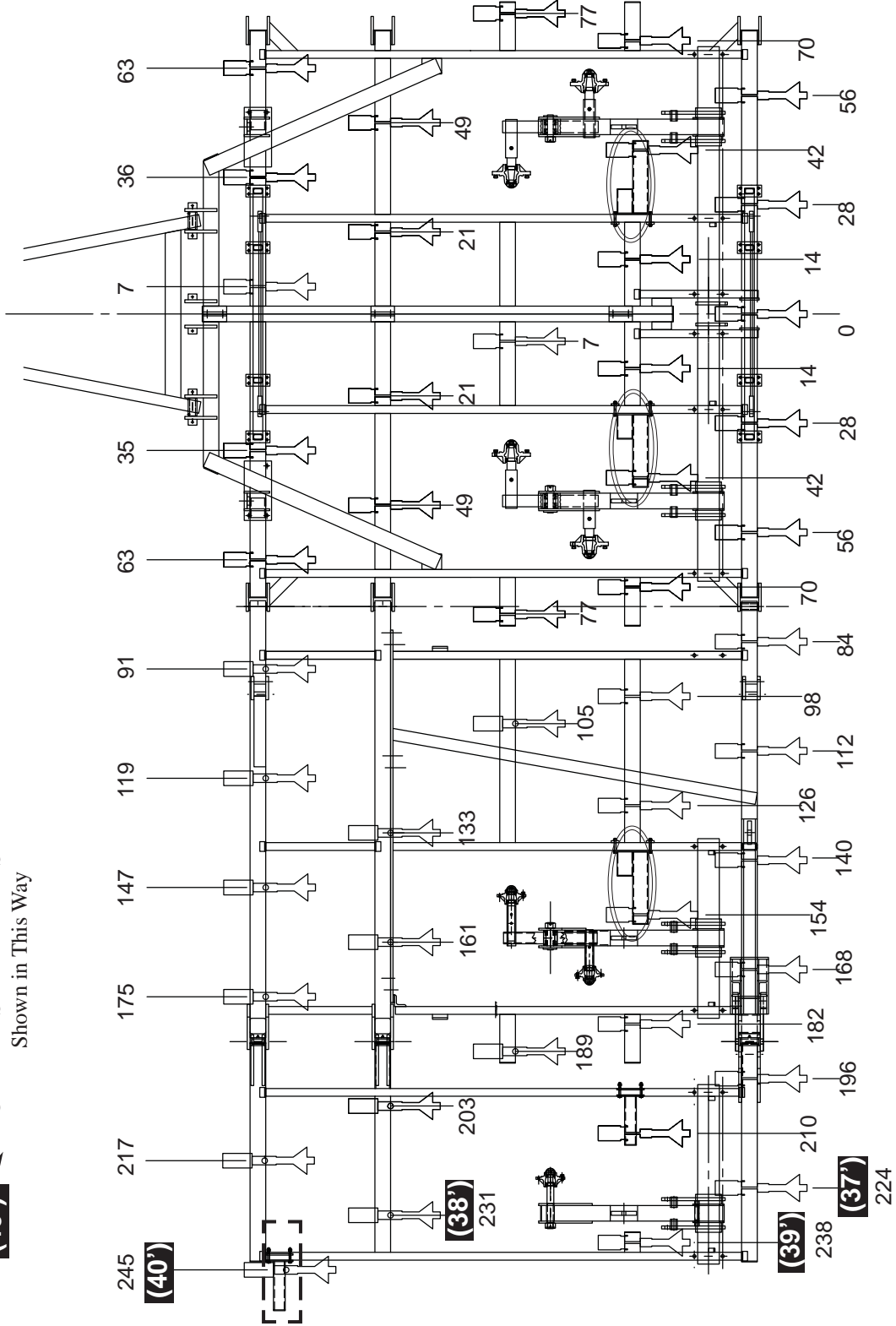

FIGURE 23

# SHANK LOCATION for Models equipped with LARGE OUTER WING

	#4K504 short extensions used	#4K504 short extensions used
42'	0	6
43'	0	6
44'	2	6
45'	4	6

**(45')** ← Outermost Shank For Each Size Machine  
Shown in This Way

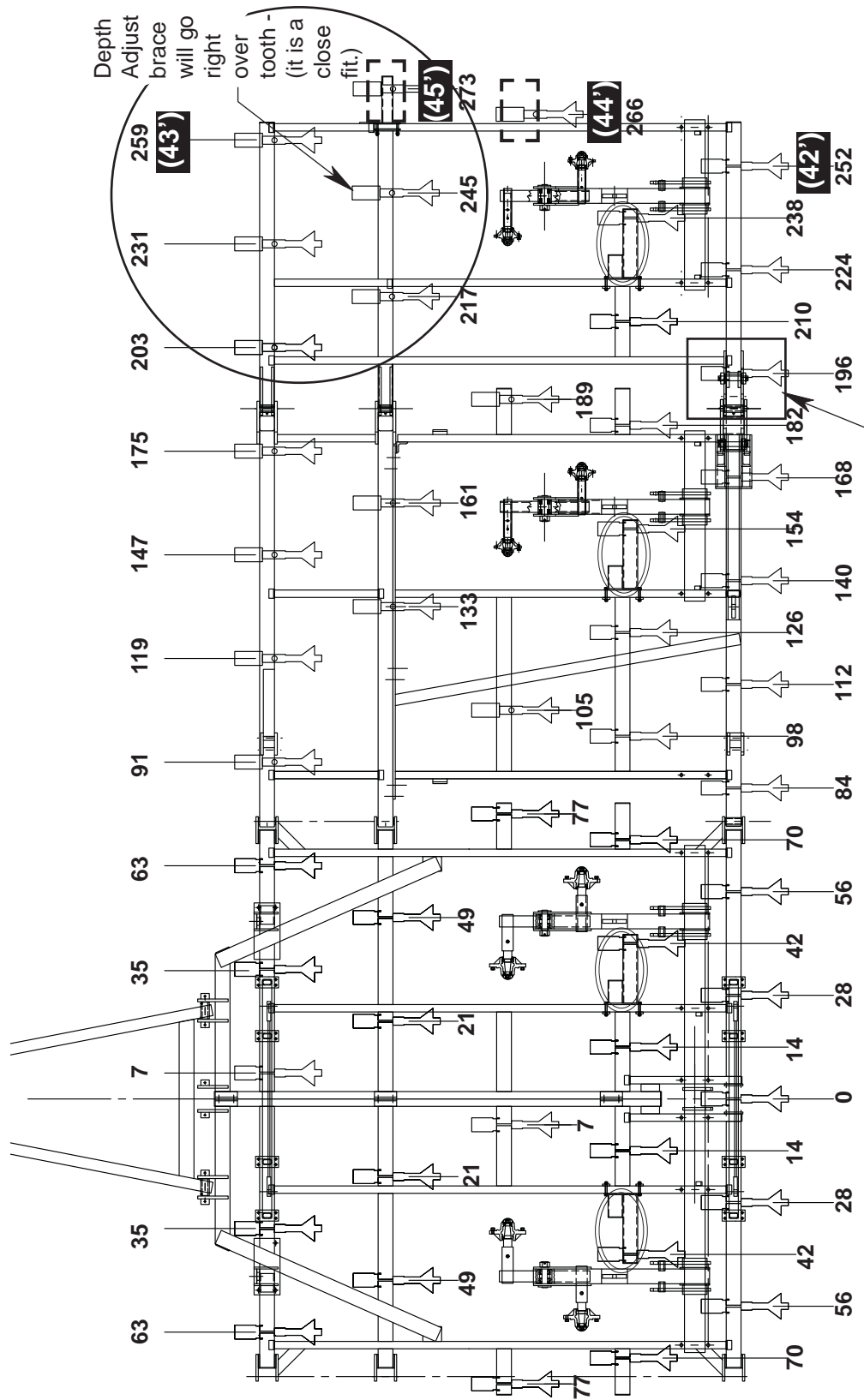

FIGURE 24

This Page Left Blank Intentionally

## ASSEMBLING THE HYDRAULICS

Follow exactly the schematic drawings on the following two pages and the larger ones found in the instruction packet to avoid tangling or breaking the hoses or damaging the system. The assembly instructions are divided into two parts - the gage wheel hydraulics show the hose routing for raising and lowering the machine; the wing lift hydraulics show the hydraulics for the folding of the wings.



**Check all hoses, fittings and connections while cycling and make any adjustments that may be necessary.**





# WING LIFT HYDRAULICS

FIGURE 26

Assemble hose clamps as in diagram; Use one clamp where routing uses single hose or 2 clamps where two hoses must be routed together.

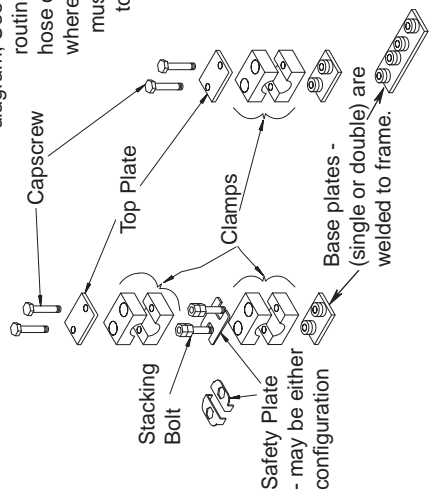

- 4K912 MALE TRACTOR TIP (2)
  - 4K602 ST. ADAPTOR (O-RING & FLARE) (2)
  - 4K611 HOSE, 42" LONG, FE-MALE ENDS (2)
- TIGHTENING PROCEDURE FOR 37° JIC SWIVEL FEMALE NUTS
1. CHECK FLARE AND FLARE SEAT FOR DEFECTS
  2. LUBRICATE THE CONNECTION.
  3. INSTALL HOSES WITHOUT TWISTS.
  4. HAND TIGHTEN UNTIL CONNECTION BOTTOMS.
  5. USING 2 WRENCHES TO PREVENT TWISTING, ROTATE THE SWIVEL NUT 2 WRENCH FLATS (1/3 TURN).
  6. FOR REASSEMBLY, FOLLOW THE SAME PROCEDURE BUT TIGHTEN ONLY 1 WRENCH FLAT (1/6 TURN).

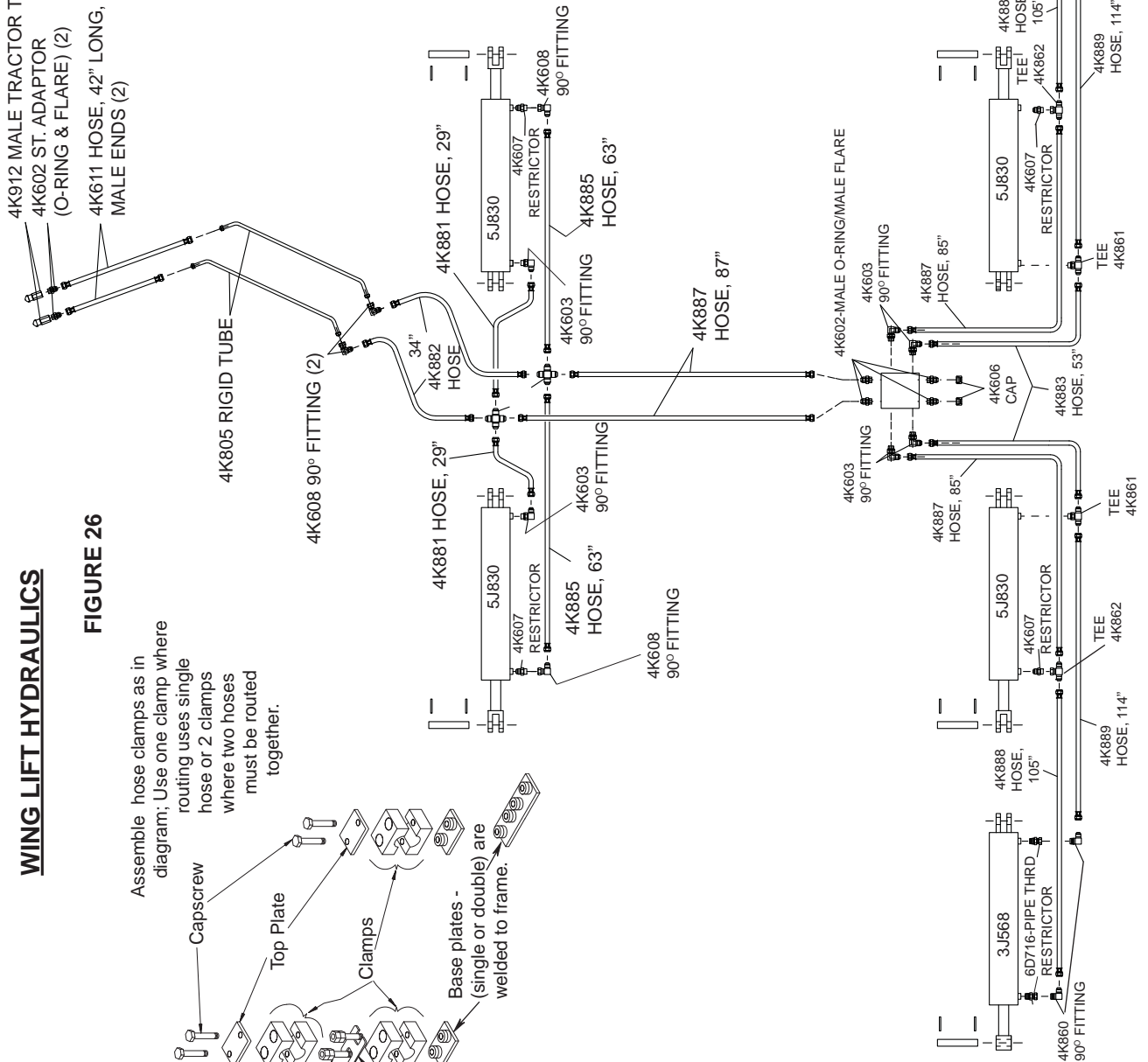

## INSTRUCTIONS FOR #4K820 WARNING LIGHT KIT

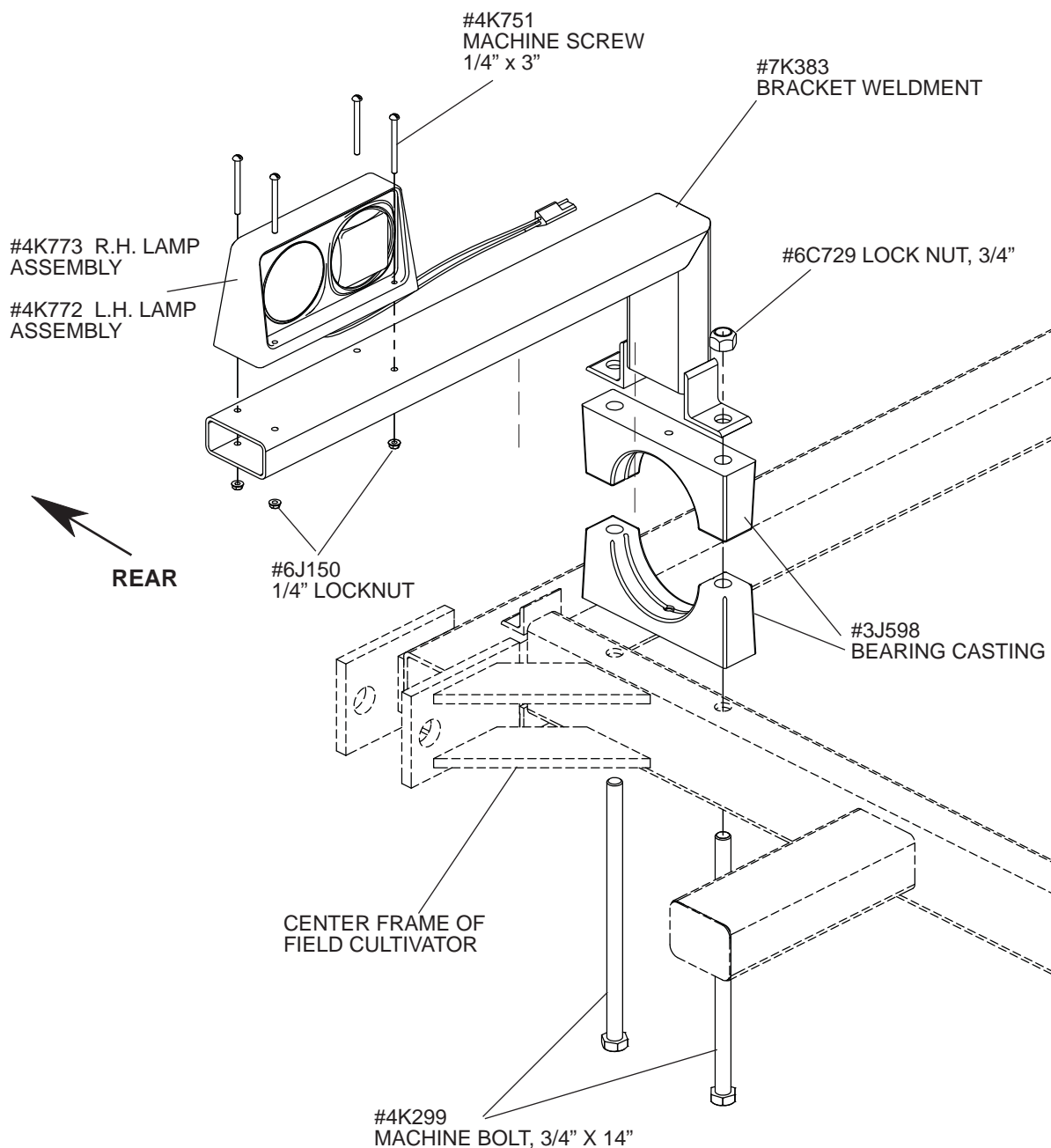

Assemble #8K383 bracket weldment to right side of machine center frame. Attach on top of center rockshaft bearing castings to outer center frame member, and bolt down with bearing fasteners. See illustration above. Assemble the other bracket weldment in similar fashion on left side of machine. Attach lamp assemblies with fasteners shown (amber facing forward; red and amber facing rearward with amber in outer-most position.) With brackets assembled, follow the wiring instructions on page 2.

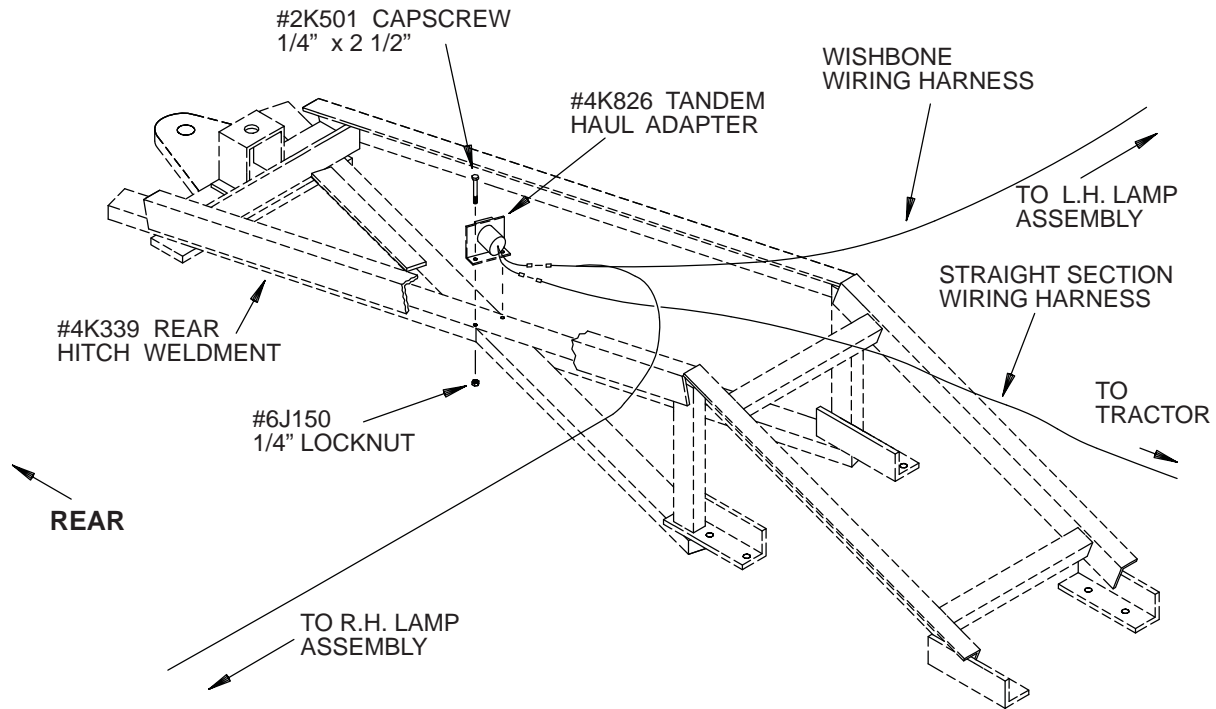

If your Field Cultivator is equipped with a rear hitch, for tandem towing another implement, you'll need to assemble the #4K826 tandem haul adapter to the rear hitch as shown . (Warning lights from second implement can be plugged into this adapter so warning lights are fully functional on both implements). Attach center connector of "wishbone" wiring harness to tandem haul adapter. Then run wishbone harness ends over to L.H. and R.H. lamp assemblies. (***Important: wires are color coded on wishbone harness. Run end with yellow wire along rear frame member to left side lamp assembly, and assemble connectors. Run end with green wire, along rear frame member to right side lamp assembly, and assemble connectors.***) Attach "straight section" wiring harness connector to tandem haul adapter. Then run this harness along machine frame members over to front of drawbar.

If your machine is not equipped with a rear hitch you have no need to use the tandem haul adapter. In this case, simply plug the "straight section" connector into the center connector of the wishbone harness. Then run wires to lamp assemblies along rear frame member as described above.

All wires must be firmly attached to machine frame members so they don't droop or become torn loose by field debris. Use plastic cable ties, provided, and electrical tape to secure all wiring.

## SPIKE TOOTH DRAG

Refer to the location charts on pages 37-42. These drawings show the location of the drag supports and the width and part numbers of the drag assemblies needed for a particular field cultivator. Dimensions are from the center of the cultivator to the center of the drag support.

A. Center section. The center section of all the field cultivators use the same drag assembly.

1. Fasten 4 drag supports to the rear tube of the center frame using 2 U-bolts for each support.
2. Bolt the support chains of the drag assembly to the drag supports using 7/16 x 3 1/2" long capscrews with a flat washer and a 7/16" locknut. On Brillion Field Cultivators, support the drags by the fourth link from the end (3 links are left hanging).

B. Wing sections.

1. Use the charts on pages 37-42 to locate the drag supports and the drag assemblies used for your particular cultivator.
2. Attach the drag supports to the wing frames at the proper locations.
3. Attach the chains to the support arms in the same way as they were attached for the center section.

## ADJUSTING SPIKE TOOTH DRAGS

The tooth angle is preset and cannot be changed. All harrow adjustments are made by adjusting the length of the draft chains. Shortening the draft chains tends to lift the front of the harrow and is helpful when plugging becomes a problem in heavy trash. In operation, the draft chains should be pulling the drag and the support chains should be slack, in transport, the support chains should be holding the drag, and the draft chains should be slack.

KIT #4K752

37' MACHINE-SPIKE DRAGS

LOCATION OF SPIKE SUPPORT BARS,  
SPIKE GANS & SPIKE SUPPORT CHAINS  
(SPIKE SUPPORT DIMENSIONS ARE LOCATED  
FROM THE MACHINE CENTER LINE)

FIGURE 27a

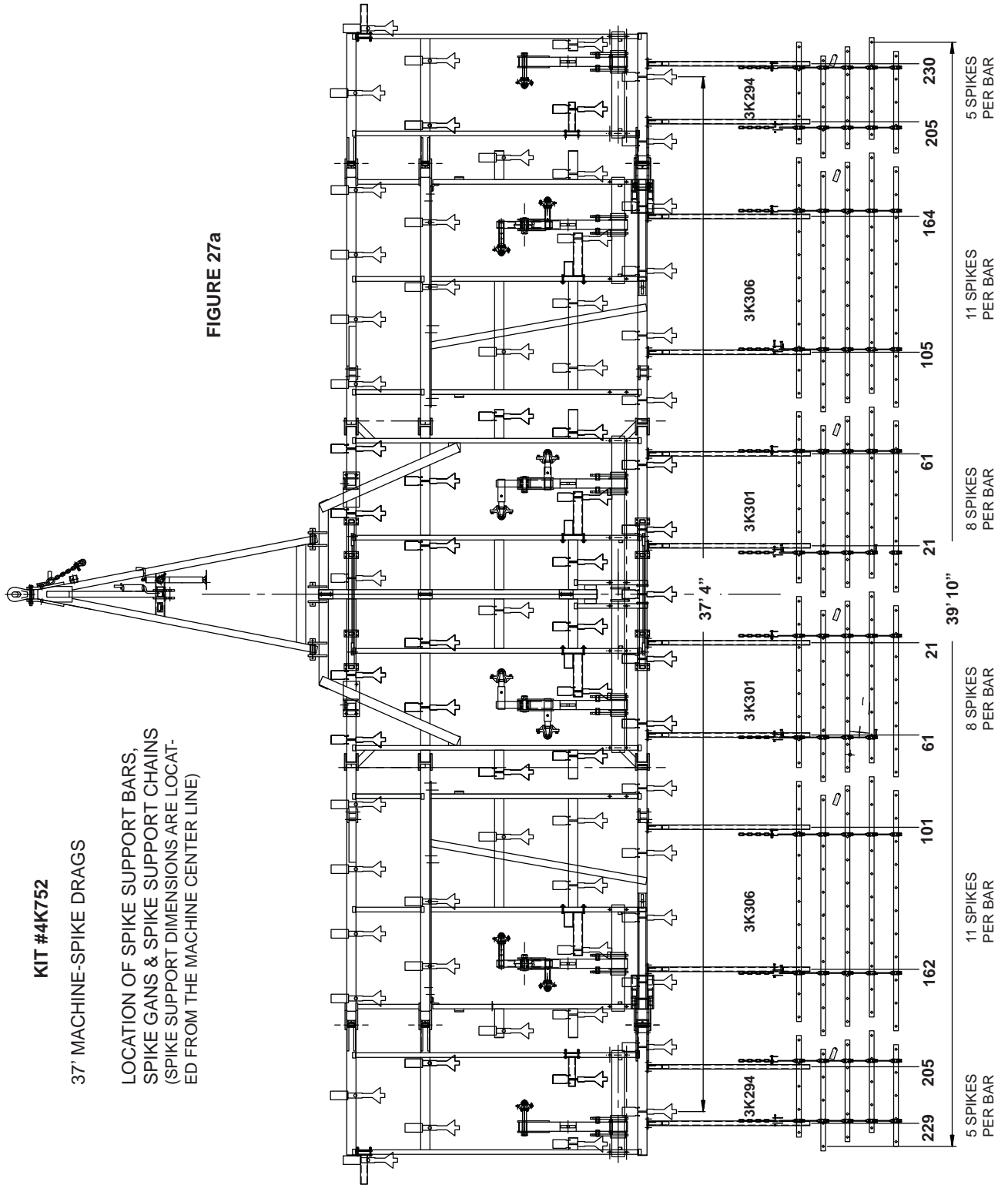

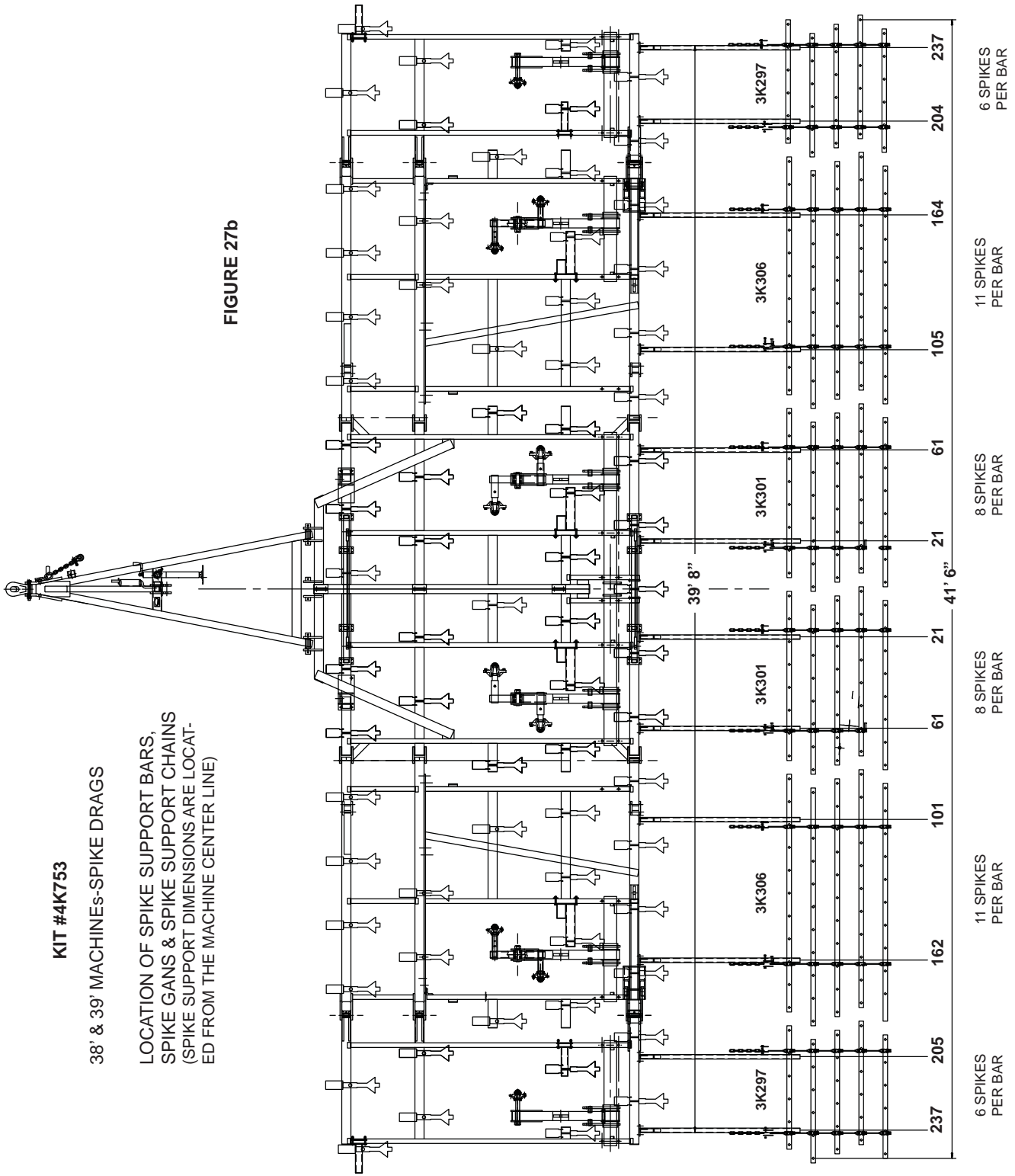

**KIT #4K753**

**38' & 39' MACHINES-SPIKE DRAGS**

**LOCATION OF SPIKE SUPPORT BARS,  
SPIKE GANS & SPIKE SUPPORT CHAINS  
(SPIKE SUPPORT DIMENSIONS ARE LOCATED  
FROM THE MACHINE CENTER LINE)**

**FIGURE 27b**

**KIT #4K754**

**40' MACHINE-SPIKE DRAGS**

LOCATION OF SPIKE SUPPORT BARS,  
SPIKE GANGS & SPIKE SUPPORT CHAINS  
(SPIKE SUPPORT DIMENSIONS ARE LOCATED  
FROM THE MACHINE CENTER LINE)

**FIGURE 27c**

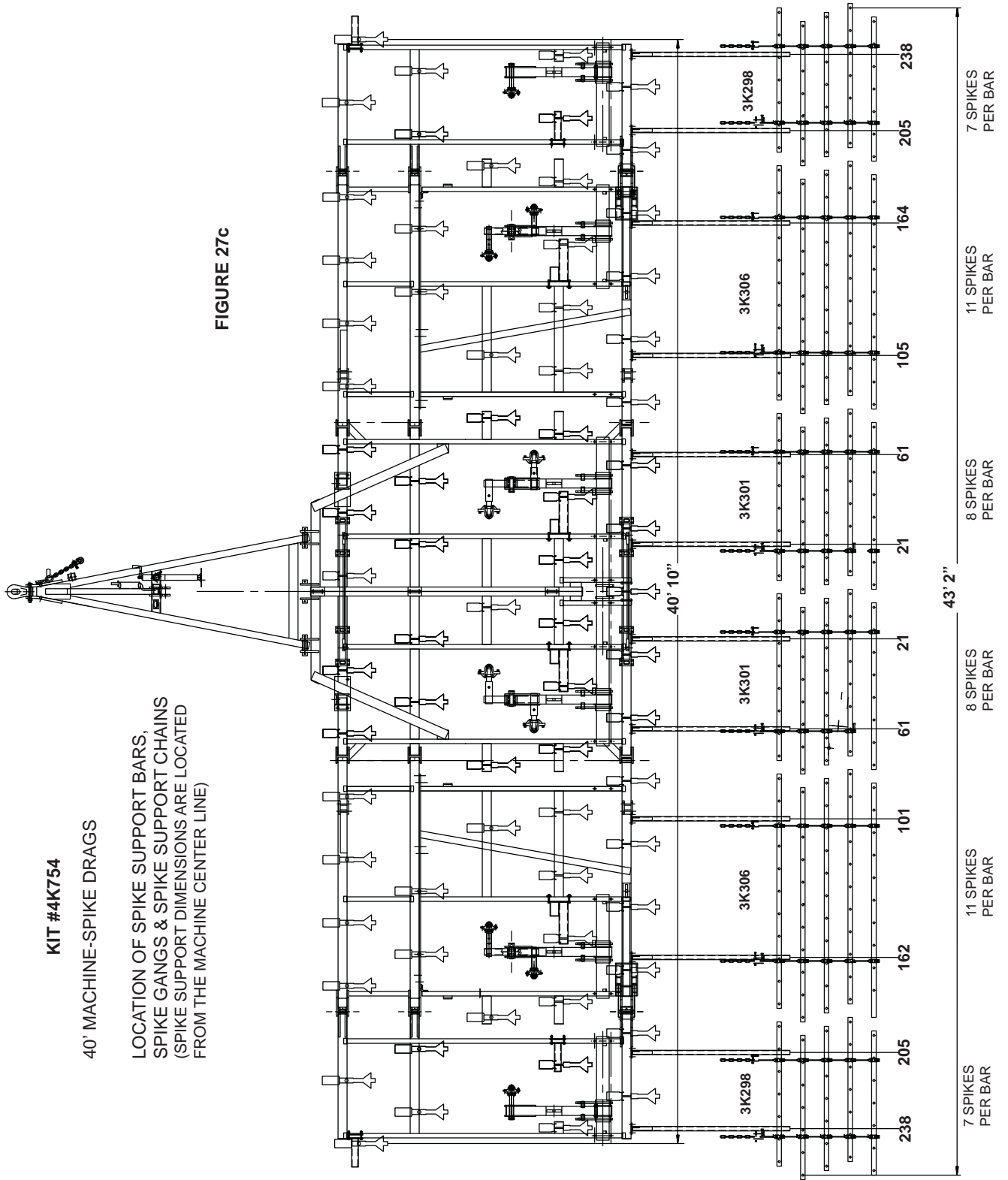

**KIT #4K755**

**42' & 43' MACHINE-SPIKE DRAGS**

LOCATION OF SPIKE SUPPORT BARS,  
SPIKE GANGS & SPIKE SUPPORT CHAINS  
(SPIKE SUPPORT DIMENSIONS ARE LOCATED  
FROM THE MACHINE CENTER LINE)

**FIGURE 27d**

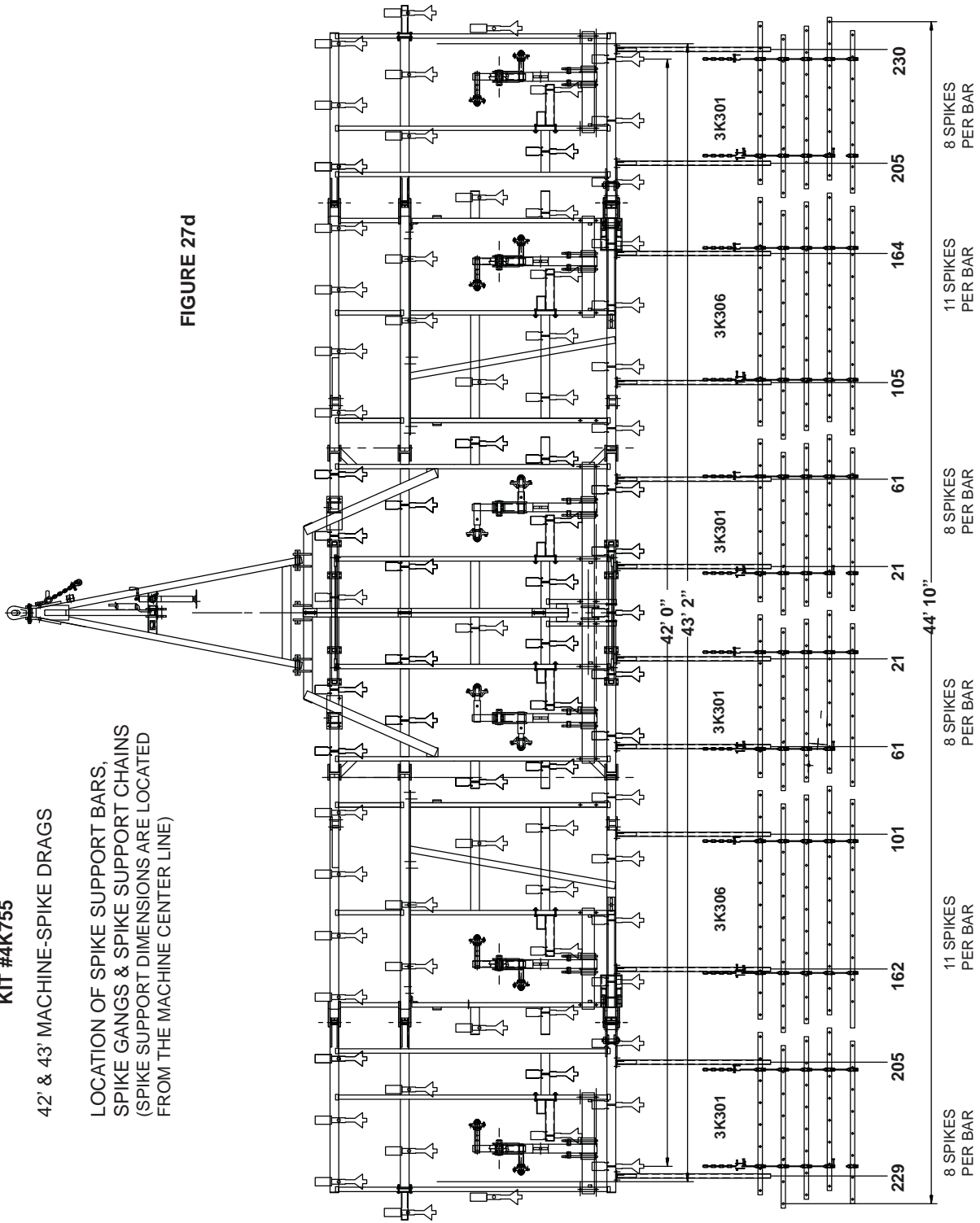



**KIT #4K756**

**44' MACHINE-SPIKE DRAGS**

LOCATION OF SPIKE SUPPORT BARS,  
SPIKE GANGS & SPIKE SUPPORT CHAINS  
(SPIKE SUPPORT DIMENSIONS ARE LOCATED  
FROM THE MACHINE CENTER LINE)

**FIGURE 27e**

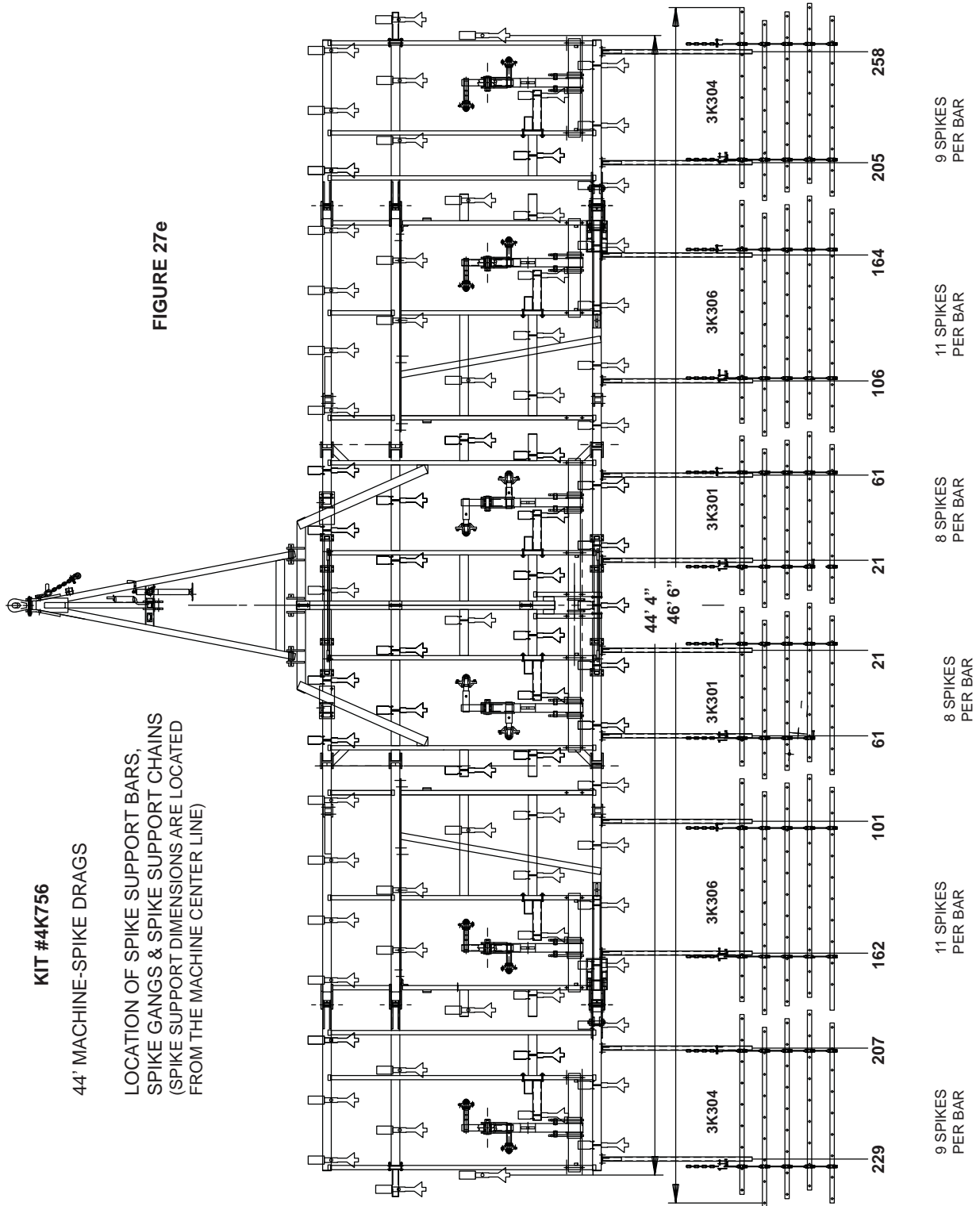

**KIT #4K757**

**45' MACHINE-SPIKE DRAGS**

LOCATION OF SPIKE SUPPORT BARS,  
SPIKE GANGS & SPIKE SUPPORT CHAINS  
(SPIKE SUPPORT DIMENSIONS ARE LOCATED  
FROM THE MACHINE CENTER LINE)

**FIGURE 27f**

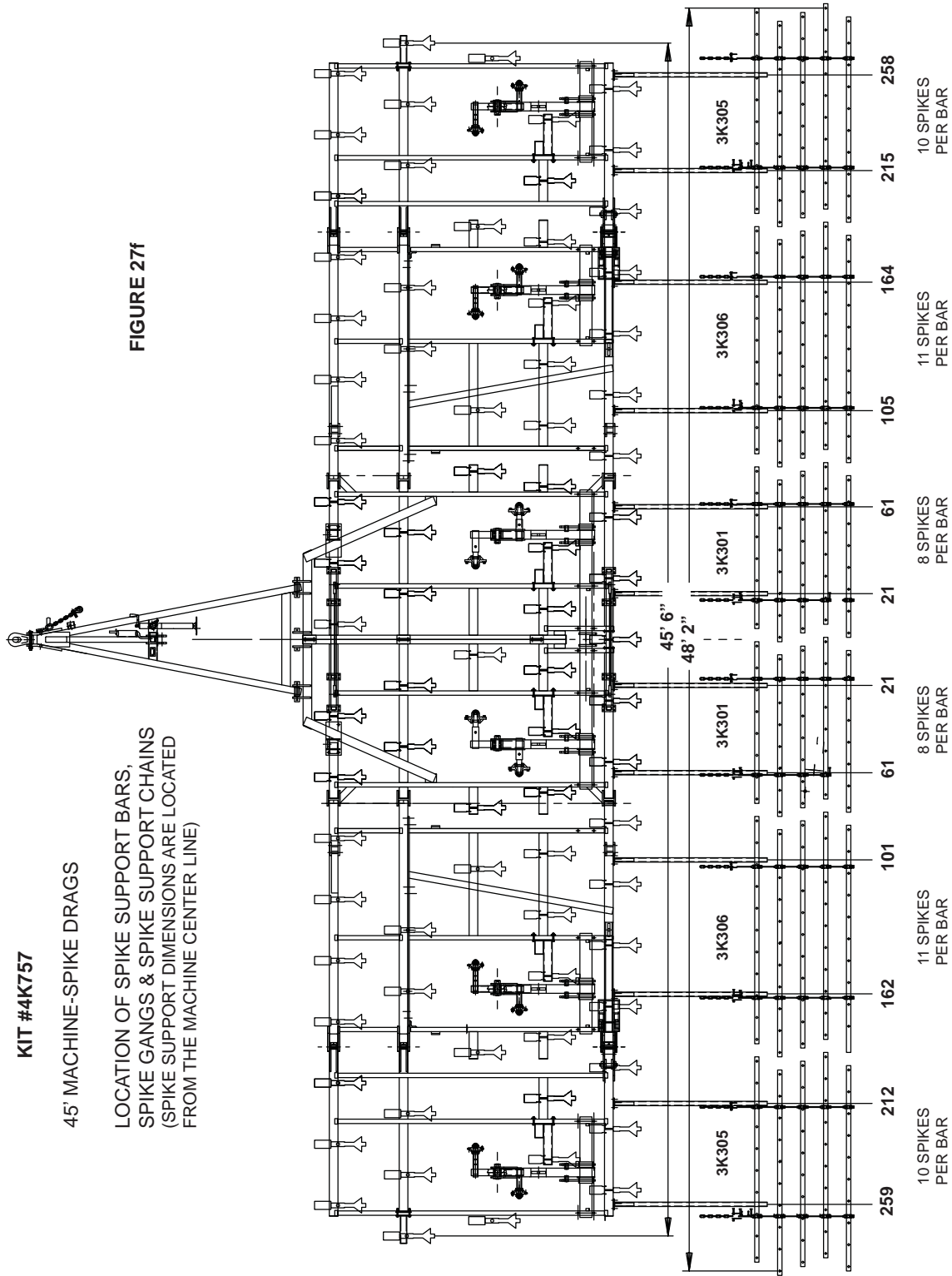

This Page Left Blank Intentionally

## COIL TINE HARROWS

Refer to the location charts on pages 44-48. These drawings show the location of the carrier arms on the rear toothbar of the cultivator and the location and sizes of the coil tine sections. The 57" wide and 72" wide coil sections each require only one carrier arm per section, the 87" wide coil tine section requires two carrier arms per coil section.

- A. **Fasten the carrier arms to the rear tube of the cultivator locating them as shown on the chart. Use the hardware assembled to the carrier arms.**
- B. **Attach the coil sections to the carrier arms using the U-bolts attached to the coil sections. Adjust the angle of the coil sections so that the coil tines will be approximately level in the operating position.**

### ADJUSTING COIL TINE HARROWS

Coil tine height can be adjusted by locating the pressure rod in different holes on the carrier arms. Downward pressure can be adjusted by repositioning the collar below the long spring. The angle of the entire coil section can be changed by loosening the U-bolts which mount the section to the carrier arm. Finally the pitch of the coil tines can be changed by changing the position of the bar adjust lever. Moving the lever forward makes the operating angle less severe and aids in trash flow. Operating the lever to the rear makes the coil tines more aggressive when operating in cleaner fields and is especially valuable when using your cultivator for incorporating chemicals.

**KIT #4K758**

**37' & 38' MACHINES-COIL TINE DRAGS**

LOCATION OF COIL TINE SUPPORT  
BARS, & COIL TINE GANGS  
(COIL TINE SUPPORT DIMENSIONS ARE LO-  
CATED FROM THE MACHINE CENTER LINE)

**FIGURE 28a**

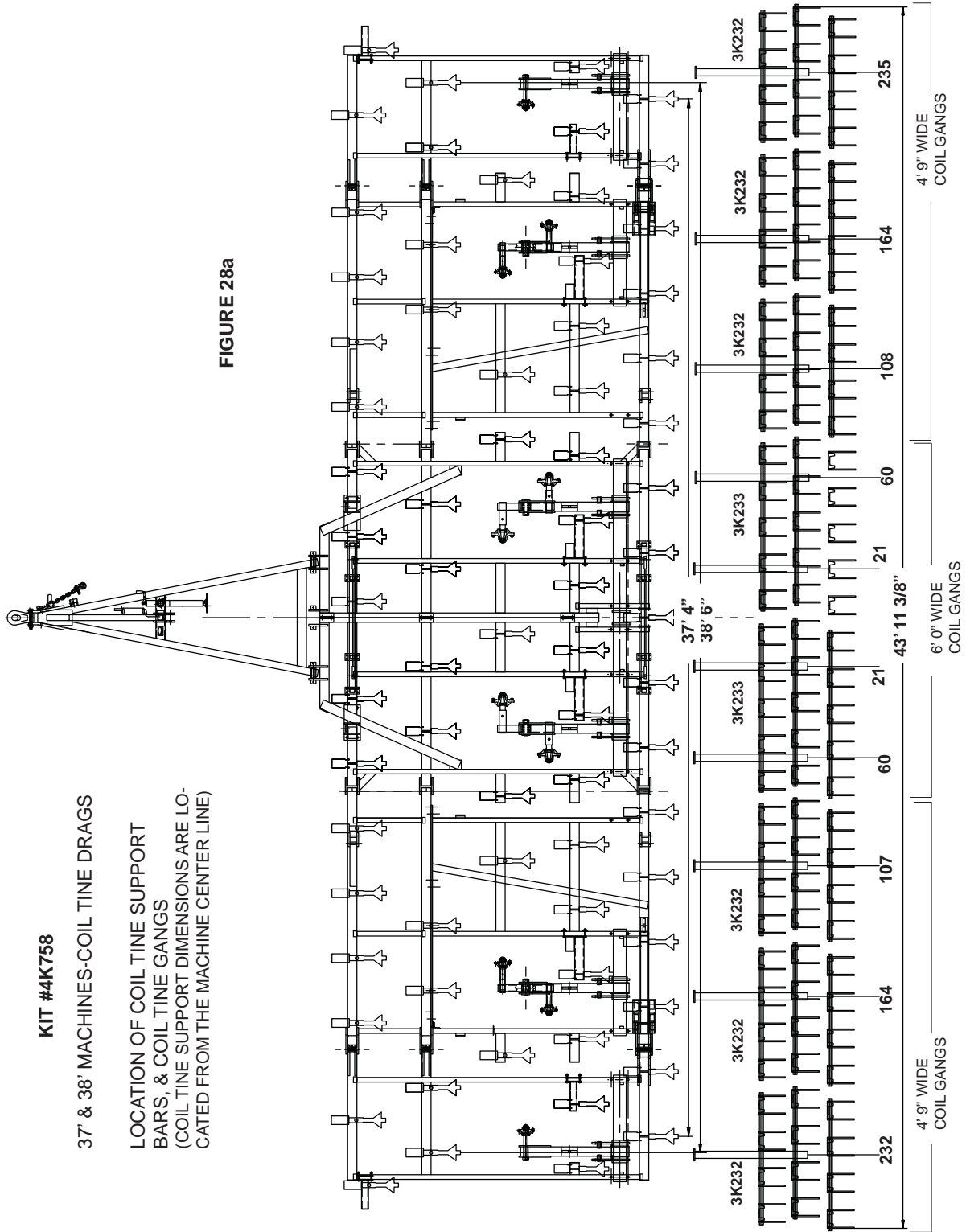

**KIT #4K759**

39' MACHINES-COIL TINE DRAGS  
(EXTENSIONS ADDED AT: ( ) ).  
LOCATION OF COIL TINE SUPPORT  
BARS, & COIL TINE GANGS  
(COIL TINE SUPPORT DIMENSIONS ARE LO-  
CATED FROM THE MACHINE CENTER LINE)

**FIGURE 28b**

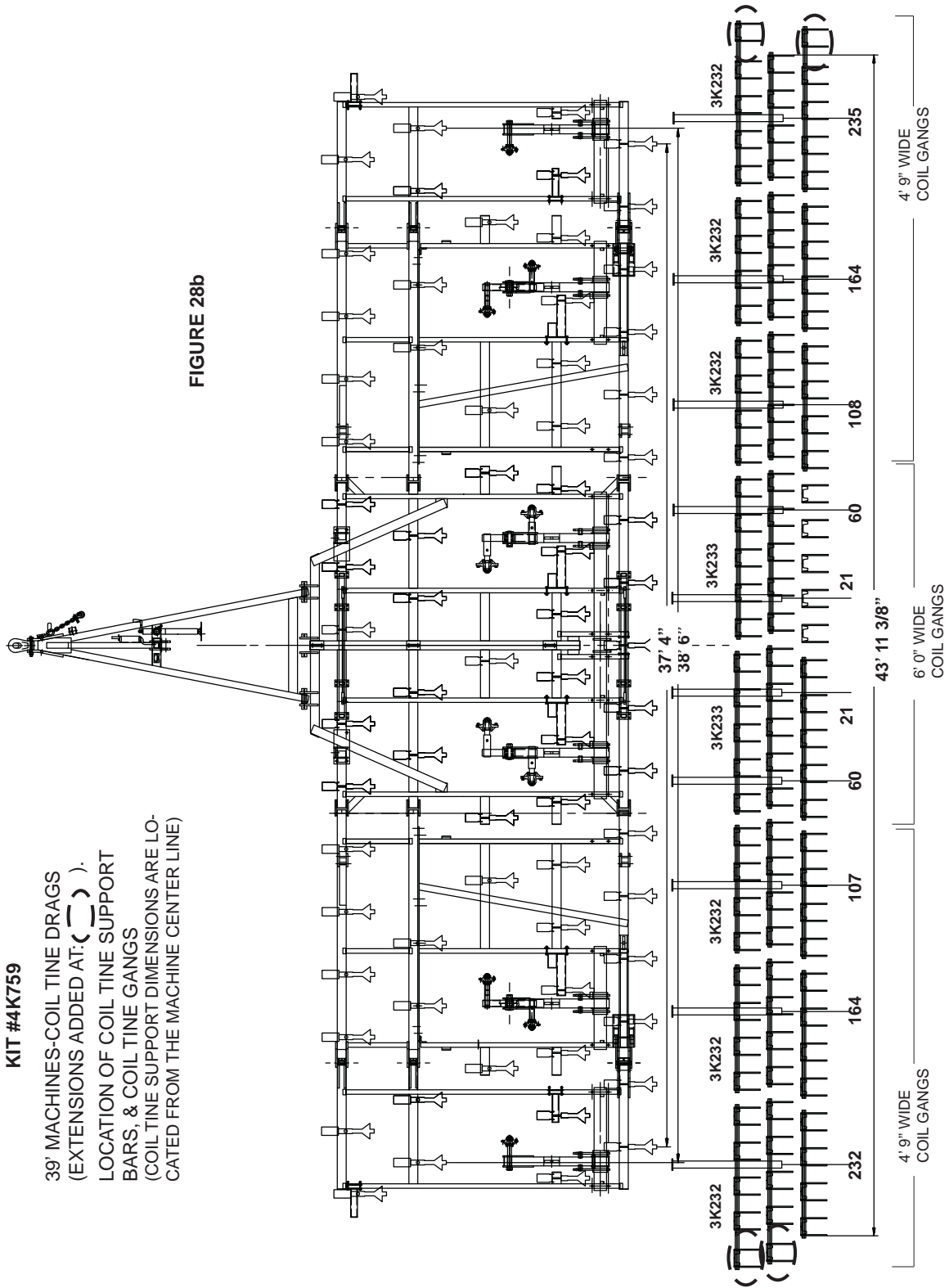

**KIT #4K760**

40' & 42' MACHINES-COIL TINE DRAGS

LOCATION OF COIL TINE SUPPORT  
BARS, & COIL TINE GANGS  
(COIL TINE SUPPORT DIMENSIONS ARE LO-  
CATED FROM THE MACHINE CENTER LINE)

**FIGURE 28c**

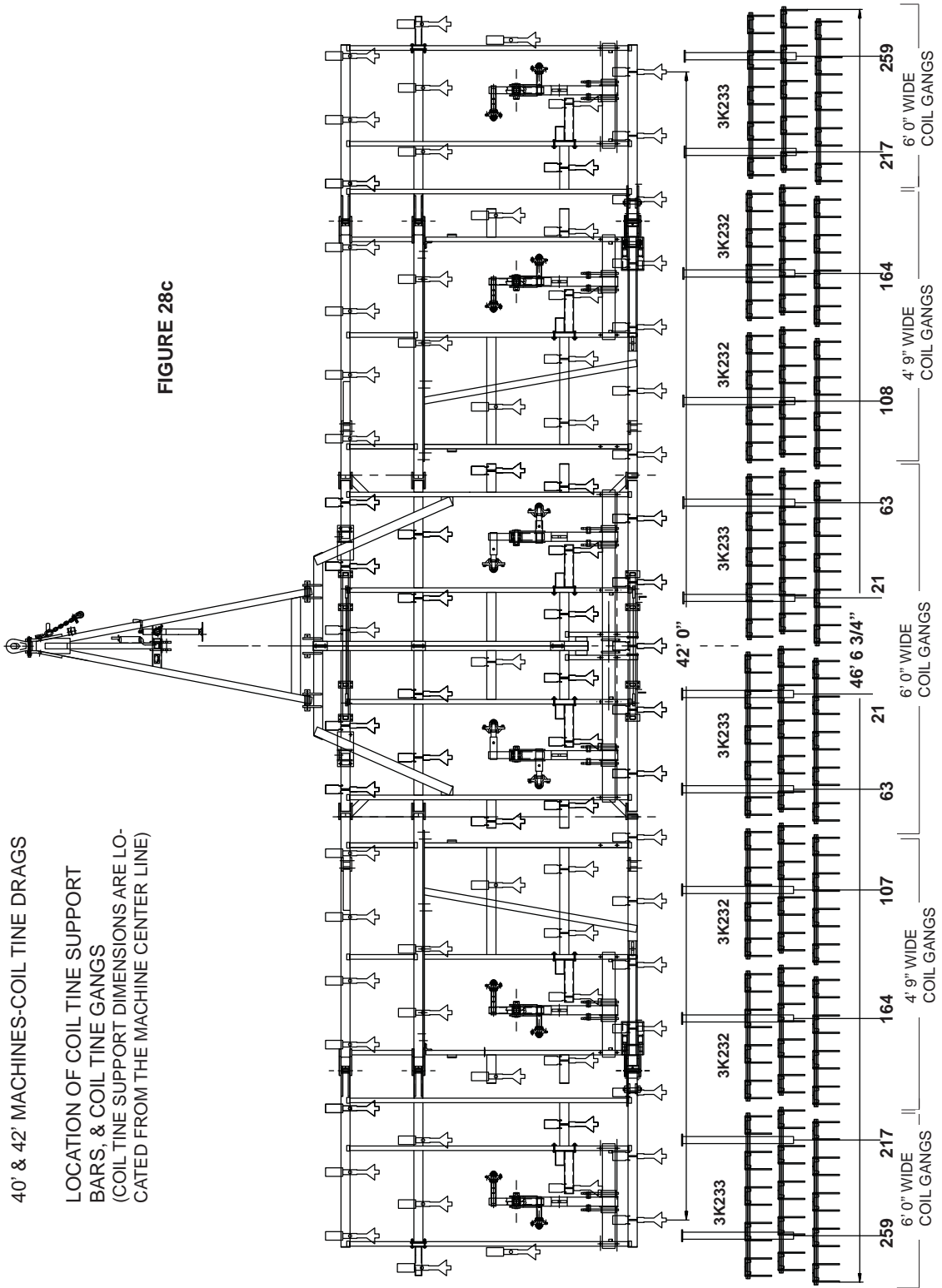

**KIT #4K761**

43' & 44' MACHINES-COIL TINE DRAGS

LOCATION OF COIL TINE SUPPORT  
BARS, & COIL TINE GANGS  
(COIL TINE SUPPORT DIMENSIONS ARE LO-  
CATED FROM THE MACHINE CENTER LINE)

**FIGURE 28d**

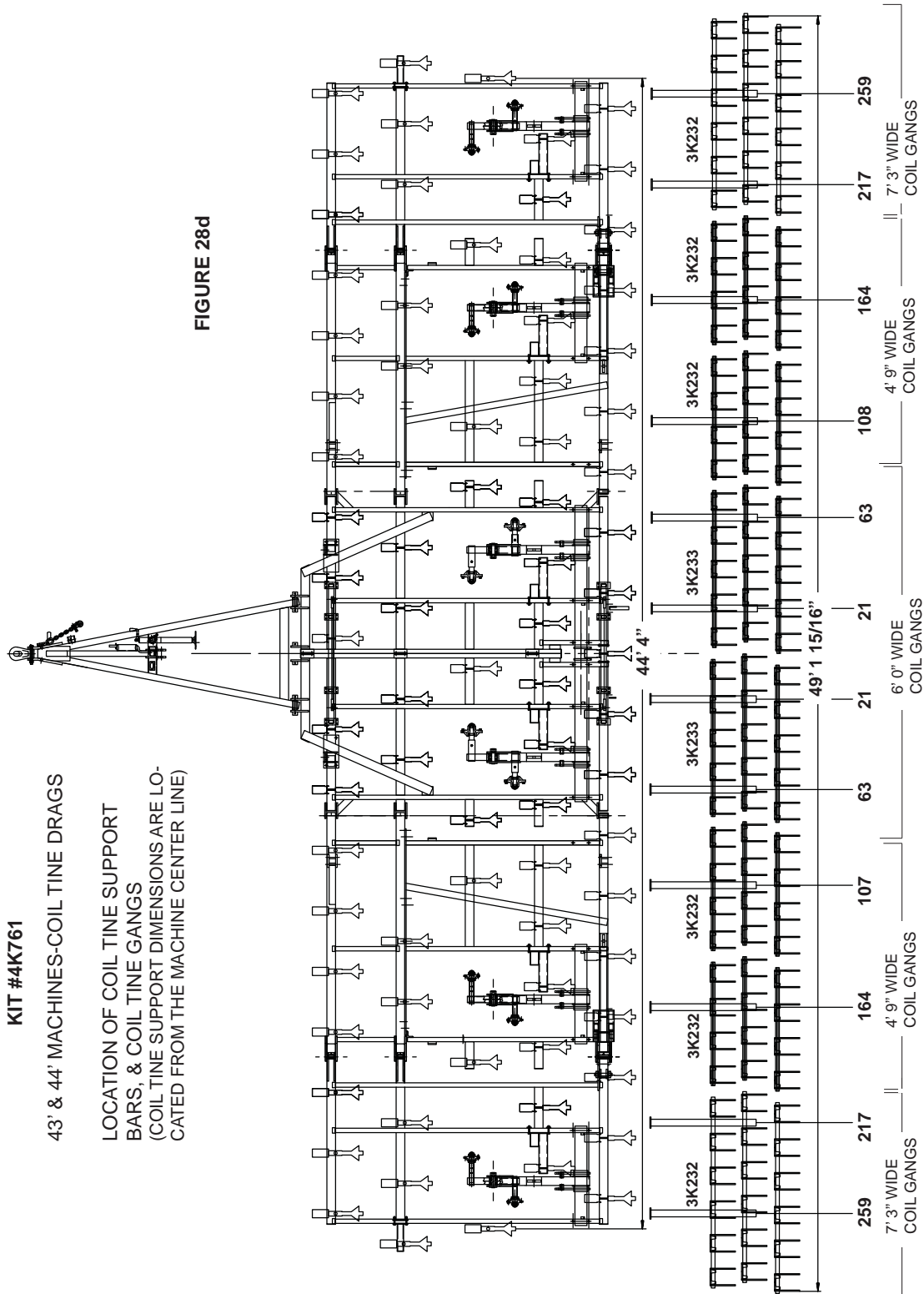



**KIT #4K762**

45' MACHINES-COIL TINE DRAGS  
(EXTENSIONS ADDED AT ( ) ).  
LOCATION OF COIL TINE SUPPORT  
BARS, & COIL TINE GANGS  
(COIL TINE SUPPORT DIMENSIONS ARE LO-  
CATED FROM THE MACHINE CENTER LINE)

**FIGURE 28e**

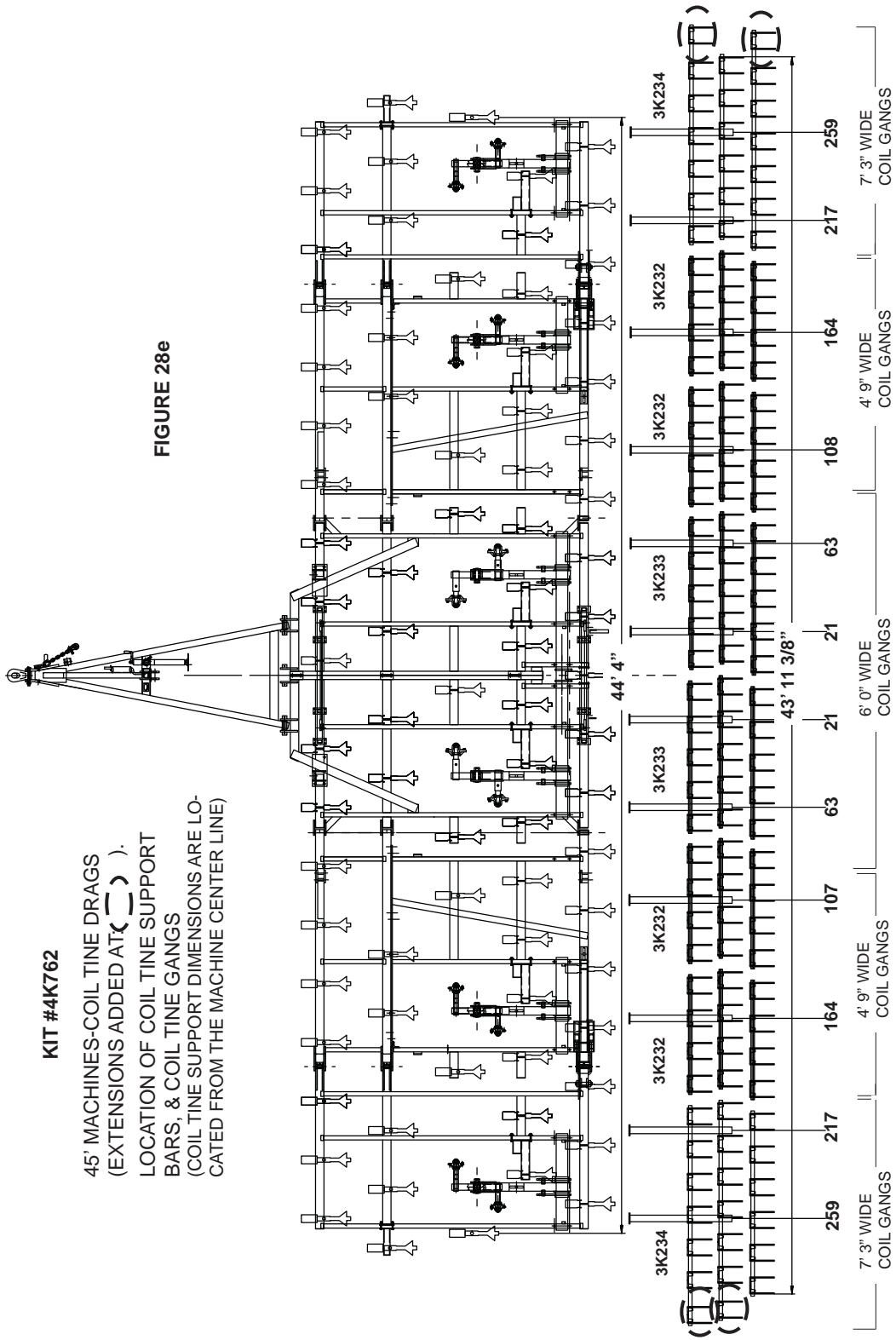

## TROUBLE SHOOTING

### Sweeps or shovels do not penetrate evenly

POSSIBLE CAUSE	SUGGESTED REMEDY
Worn sweeps or shovels	Replace
Incorrect sweep angle	Replace with sweeps having 47 degree stem angle
Field cultivator not level	Level the cultivator, both front to rear and side to side See <u>Level Adjust</u> , page 8.
Cylinders not retracting completely	Bleed air from system. Rephase hydraulic cylinders. See hydraulic hoses on pages 34 & 35.
Wings not following contour of the ground	Extend wing lift cylinders completely, allowing wings to float.
Outside front of wing "nose-dives"	Adjust wing gage wheels.
Inadequate spring tension	Increase spring preload by turning bolt into spring end on shank spring. One turn on bolt increases point pressure approximately 5 pounds.
Extremely hard ground	Use Heavy duty, 2 inch wide reversible points in place of sweeps (Brillion part no. 2J605), and/or make 2 passes with the first at a shallower depth.

### Shanks stretching

Shank pivot is seized	Free up the pivot and lubricate.
Too much spring pressure	Loosen bolt which preloads shank spring, each turn of the bolt reduces point pressure by approx. 5 lb.  Shank casting is clamped too tight to spring end, the bolt should allow the spring to pivot in the casting.

### Shanks wobble

Pivot bolt is loose	Tighten the pivot bolt.
Shank mount bolts are loose	Tighten the bolts equally.

### Machine does not raise or lower properly

Cylinders not synchronized properly	Bleed air from system. Rephase hydraulic cylinders. See page 8.
Cylinders connected in wrong sequence	See charts on pages 34 & 35.

Hoses not connected properly	See charts on pages 34 & 35.
Hydraulic hose ends not working properly	Replace hose ends
<b>Wings do not fold properly</b>	
Too fast	Make sure restrictors are installed in the circuit.
Too slow	Check tractor flow adjustment and hydraulic pressure. 2000 PSI is required to fold large machines with spike tooth harrows mounted to rear tooth bar.  Make sure hydraulic hose ends are functioning properly, if not, replace.
Wings are not even when folded	Center the cylinder anchor on the rear tooth bar. Relocate the wing braces.
Cylinder leakage, external or internal	Repair or replace the cylinder.
<b>Plugging</b>	
Incorrect shank location	Refer to shank locating charts on pages 32 & 33.
Plugging at wheel with S-tine	Be sure to use shank mount to locate S-tine rearward in the area next to the tire. See the shank locating charts on pages 32 & 33.
Too much trash	Operate at an angle to the rows if possible. Make sure that your combine is spreading the stalks. In extreme conditions it may be necessary to shred or disk the stalks before cultivating.
<b>Tire and shank interference</b>	
Tire strikes S-tine in transport position	Use the hole in walking beam which will position the inner wheel farthest from the wheel arm.
Tire strikes sweep	Check shank spacing charts. Only 9 inch wide sweeps can be used in the area adjacent to tires.
<b>Cultivator does not follow properly</b>	
Machine is not leveled properly	Level the cultivator front to rear and side to side. See level adjust, page 8.
Incorrect shank locations	See shank locating chart on pages 32 & 33.
Unequal tire diameters	Check tire diameters and inflation pressures.
Towed implement is causing side loading	Check operation of any implement you are towing

**SPECIFICATIONS**  
(Subject to change for product improvement)

**Model Designation**

The basic model designations are:

“HFCT”    **H**igh clearance **F**ield **C**ultivator, equipped with **T**andem wheels on center and wings.

The numbers following the letters indicates the approximate machine width in feet between the centers of the two outermost shanks on the machine.

**Basic Machine Specifications**

Operating depth range .....	0 to 5 inches
Shank clearance .....	26 inches from bottom of frame to sweep tip
Road clearance .....	9 to 14 inches (varies with operating depth)
Shank trip height .....	13 1/4 inches
Shank trip force .....	142 pounds
Shank spacing .....	7 inch center to center, no shanks closer than .....28” on any tooth bar
Front to rear spacing.....	30 inch on rear bar, 32 inch all others
Sweeps .....	4J809 - 9” Std. sweep, 47 degree shank angle .....4K442 - 9” “Ultra Wing” sweep
Points .....	4J801 - 2 inch wide reversible point
Shank Material .....	9/16 x 1 3/4 alloy steel
Pivot .....	Greaseable bushing
Main frame & wings.....	5 bars of 3” x 4” tubing
Overall length .....	24 feet, 3 inches
Maximum Transport heights.....	13’ 4” (optional spike harrows add to transport height & width)

**Wheels & tires**

Center section .....	Walking tandem with (4) 12.5L-15 tires
Inner Wings.....	Walking tandem with (4) 9.5L-15 tires
Outer Wings, 37’ thru 40’ machines.....	Single tire - (2) 9.5L-15
Outer Wings, 42’ thru 45’ machines.....	Walking tandem with (4) 9.5L-15 tires









---

# Intertek

Equipment from Landoll Corporation is built to exacting standards ensured by ISO 9001:2008 registration at all Landoll manufacturing facilities.

## **LANDOLL CORPORATION**

1900 North Street

Marysville, Kansas 66508

(785) 562-5381

**800-428-5655 ~ WWW.LANDOLL.COM**



Copyright 2010. Landoll Corporation

"All rights reserved, including the right to reproduce this material or portions thereof in any form"

---