

SETTING-UP AND OPERATING MANUAL



CART MOUNTED HARROW

STC-8, STC-81 & STC-81-1

STCW-4

STCW-6

STCW-8



BRILLION IRON WORKS, INC.
BRILLION, WISCONSIN 54110

TABLE OF CONTENTS

	<u>Page No.</u>
Introduction	3
Location Reference	3
Parts Ordering	3
Safety Suggestions	4
Adjustments	5
Operating Instructions	7
Storage	8
Assembly Instructions	9
Drawbar	9
Jack	10
Lift Arm & Cylinder	10
Center Frame	11
Wings	12
Toothbar	12
Tooth Mounting	15
Levers	15
Attaching Skids to Frame	16
Wing Brackets	16

INTRODUCTION

Your Brillion Spring Tooth Harrow is built with the best materials and workmanship available. It has been designed to give years of trouble-free operation. Proper care and operation will insure that you receive the service and long life built into this machine.

Study this manual carefully before attempting to assemble or operate the machine. A special section, "Setting Up Instructions", is included.



This safety alert symbol is used to call your attention to instructions concerning personal safety. Federal law requires you to explain the safety and operating instructions furnished with this machine to all employees before they are allowed to operate the machine. These must be repeated to the employees at the beginning of each season. Be sure to observe and follow the instructions for the safety of anyone operating or near the machine.

Location Reference

Right hand, left hand, and forward designations are those related to the operator when sitting in the operating position.

Parts Ordering

When ordering parts for this machine, include the complete model number and serial number. Refer to the name plate on the drawbar. Please record these numbers upon taking delivery of the unit.

Spring Tooth Harrow Model _____

Serial Number _____

Date Purchased _____

Be sure to read the warranty card which is shipped with the machine. Return the proper portion of the card for recording at the factory.



SAFETY SUGGESTIONS

Investigation has shown that nearly 1/3 of all farm accidents are caused by careless use of machinery. You can do your part in improving safety by observing the following suggestions. Insist that all people working with you or for you abide by them.

1. Make sure that all air is bled from the hydraulic cylinder before unfolding the wings.
2. Do not unfold wings unless harrow is attached to a tractor drawbar.
3. Be sure a flow restrictor is installed on the lowering end of the hydraulic cylinder.
4. Do not allow anyone near the machine when folding or unfolding the wings.
5. Do not make adjustment while the machine is in motion.
6. Do not allow anyone to ride on tractor or machine.
7. Relieve pressure in hydraulic lines before uncoupling hydraulic hoses from tractor. On most tractors this can be done by operating valves after engine is stopped.
8. Always use transport lock pins for wings when transporting machine.
9. Block machine so it will not roll when unhitched from tractor.
10. Do not transport at speeds over 20 mph.
11. Avoid sudden stops or turns when transporting because weight of machine may cause operator to lose control of tractor. Use a tractor heavier than machine. Do not allow tractor drawbar to swing when transporting.
12. Use caution when towing behind articulated steering tractors; fast or sharp turns may cause the machine to slip sideways.
13. Securely block machine when working on or under it to prevent injury in case of hydraulic failure or inadvertent lowering by another person.
14. Do not stand between the tractor and implement when attaching or detaching implement unless both are not moving.
15. Whenever transporting farm implements on public roads it is the responsibility of the operator to abide by state and local laws concerning wide loads, speed, safety emblems, and safety lighting equipment.

ADJUSTMENTS

Different soil types, varying soil conditions, different tire sizes, and a wide range of tractor drawbar heights require various adjustments to the harrow to get the desired operation.

The skids should run level to the ground so that the three rows of teeth operate at the same depth. To accomplish this, the pull straps should point slightly uphill in operation. Adjustments to the harrow can be made by doing any or all of the following.

(NOTE: Settings suggested are to be used as "starting points" for setting up the machine. If conditions warrant, alternate bolt holes can be used.)

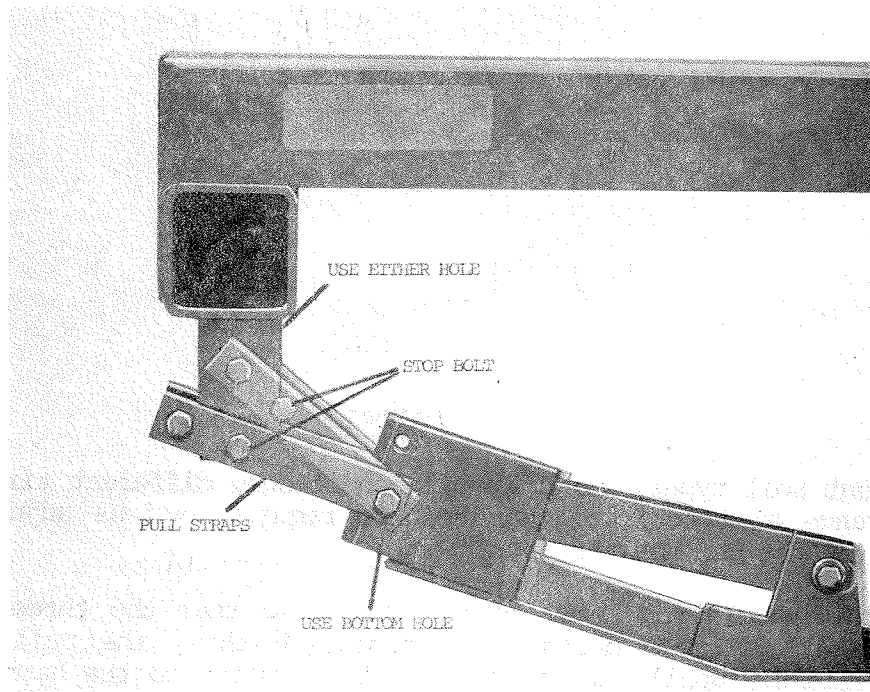

1. The pull straps can be bolted into either hole on the harrow frame.

(NOTE: When different holes on the harrow frame are used, the arrangement of the stop bolt in the pull straps is changed.)

2. The pull straps can be bolted into either hole on the skid angles. Use the bottom hole.
3. Once the above adjustments have been made, move the clevis to the proper hole in the hitch side plates so that the drawbar is level in operation. The entire hitch can be inverted for a wider range of adjustment.

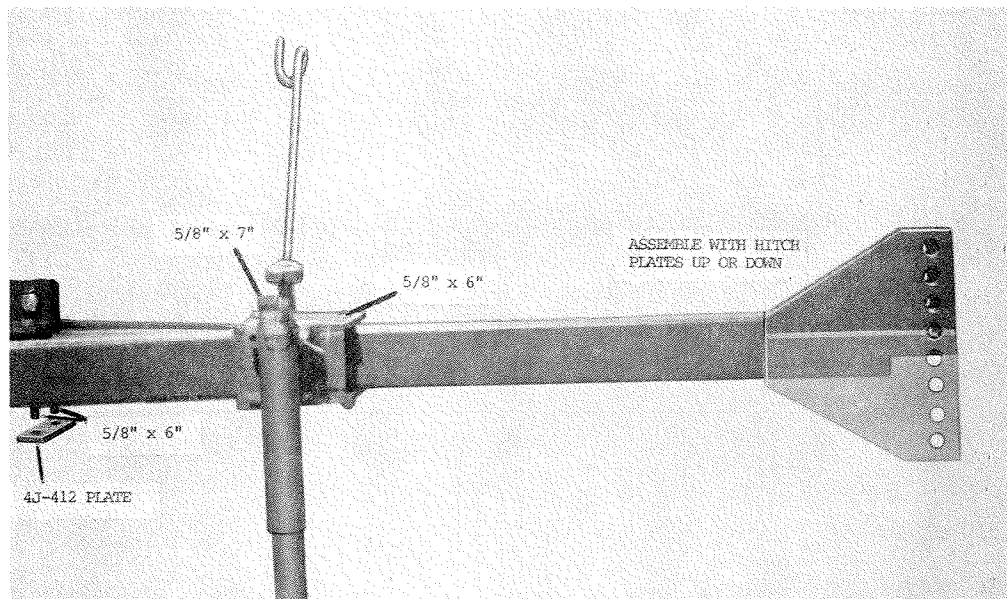

OPERATING INSTRUCTIONS



Do not unfold wings nor raise or lower machine unless drawbar is attached to a tractor and a properly bled hydraulic cylinder is connected between lift arm and cylinder anchor.

Inspect the harrow prior to operation to be sure that all nuts and bolts are tight and that it is in good operating condition. After the first few hours of operation, check bolts once again to assure they haven't loosened.

Hitch the harrow to a tractor drawbar. It is not necessary that the unit be exactly level, however several holes are provided for the clevis. The hitch tongue can also be inverted for more adjustment. Connect the hoses to the tractor outlets.

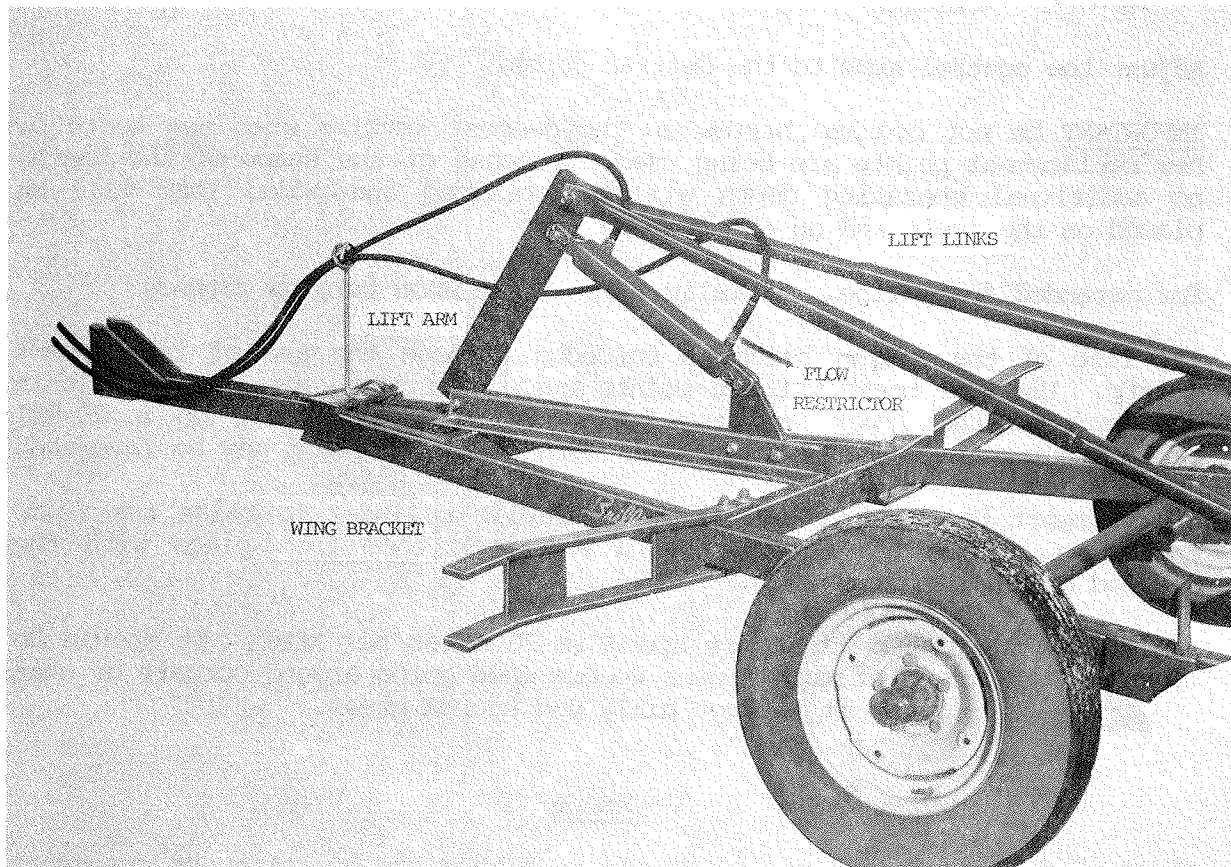

Remove the transport lock pins and unfold the wings.



Danger! When unfolding the wings, weight is transferred to the back of the machine. If the harrow is not attached to a tractor drawbar, serious injury could result.

Lower the center frames and wings to the ground by retracting the hydraulic cylinder.



Danger! If air is present in the hoses or the cylinder, the frame will drop too fast. Serious injury or damage to the machine could result. Be sure to bleed air from cylinder before attaching. Be sure a flow restrictor is installed in the lowering end of the hydraulic cylinder.



Caution! Do not attempt to retract the hydraulic cylinder without first unfolding the wings. Damage to machine will result.

Adjust the control arms to the desired depth.

IMPORTANT Do not operate harrow in the deepest setting when new teeth or new replacement points are being used. Because of the shape of the teeth, no additional operating depth will be obtained and added load will be placed on the teeth and on the frame.

For extended frame life, partially raise frame when turning corners.

The life of the spring teeth is extended through the use of replacement points. Use the teeth without points until the teeth are worn to within one inch of the lower mounting hole. At this time bolt on a 2D-551 replacement point. When this becomes worn down, the point may be reversed.

To transport the harrow, extend the hydraulic cylinder to raise the frame and wings. Fold the wings forward and lock them into place with the drilled bolt and hairpin clip.



Maximum transport speed is 20 miles per hour. It should be towed at much slower speeds when going around corners or when pulling it through hilly and uneven areas.

STORAGE

The Spring Tooth Harrow may be stored in either the operating or transport configuration.

Clean the machine and tighten all nuts before storing. Replace any worn or broken parts. The wear strips on the skid runners can be reversed if either end is worn.

Repack the transport wheel bearings with a good grade of bearing grease.

If the harrow is stored with the cylinder extended, apply a coat of grease to the cylinder rod to prevent rusting.

ASSEMBLY INSTRUCTIONS

Your Brillion STC Harrow is shipped in separate assemblies according to the following list.

Part No.	Name	Quantity or Part No.				
		STC-81 8' Center	STC81-1	STCW-4 Pair of 4' Wings	STCW-6 Pair of 6' Wings	STCW-8 Pair of 8' Wings
5J-389	Center Frame	1	1			
6J-662	Runner	3	3	4	6	6
5J-393	Tooth Bar 4'	6	6	6		12
5J-404	Tooth Bar 3'				12	
6J-678	Drawbar	1	1			
5J-396	Link Bundle	1	1			
5J-398	Hub & Spindle	2	2			
5J-400	Spring Tooth	24	24	24	36	48
5J-451	Tie Bar Bundle	1	1	1	2	2
5J-453	Wing Bracket	2	2			
8D-397	Jack Assembly	1	1			
6J-679	Lift Arm	1	1			
9D-137	Hydraulic Cylinder	1	1			
4C-129	Wheel	2				
6J-189	Flotation Wheel		2			
	Hitch			5J-397	6J-569	6J-569
	R.H. Wing			5J-405	5J-402	5J-390
	L.H. Wing			5J-406	5J-403	5J-391
	Box Assembly	(1) 5J-399	(1)	5J-418(1)	5J-447(2)	5J-399(2)
	Box Assembly	(1) 5J-401	(1)			

1. Assemble the Drawbar

If your machine has the 5 inch wide rims, mount some 7.60-15 tires on these rims. If you have the 8 inch wide rims, mount a pair of 9.5L-15 or 11L-15 tires. Insert the hub and spindle assemblies into the pipes on the drawbar.

Bolt the spindle into the pipe with 1/2" x 3" long capscrews.

Bolt the wheels to the hubs using the wheel bolts provided.

Block the tires and install the hitch tube into the drawbar. If the tractor drawbar is 14 inches or more from the ground, install the tube with the hitch plates up. If the tractor drawbar is lower, install the hitch tube with the plates to the bottom. (See the section on Adjustments) Secure the hitch tube with a 5/8" x 6" long bolt through the front hole on the drawbar plates. Use a 5/8" x 7" long bolt and a flat washer and mount the hose holder through the rear hole on the drawbar plates. Trap the rear of the hitch tube by using two 5/8" x 6" long bolts through the holes in the angles and through the 4J-412 plate. Tighten 5/8" lockwashers and nuts to all four bolts.

2. Attach the Drawbar Jack and Hitch Clevis

The jack is attached with a snap ring. Attach the hitch clevis in the desired hole with the 1" x 5-1/2" long bolt and locknut.

3. Attach the Lift Arm and Lift Links

Bolt the cylinder anchor and the lift arm between the angles on the drawbar frame with 3/4" x 3" long bolts and locknuts. The lift arm must be installed with the small hole between the two angles and the two large diameter holes to the top as shown.



Danger! Bleed air from the hydraulic cylinder before attaching it to the harrow.

Attach the hydraulic cylinder between the anchor and the lift arm. The base end of the cylinder must be pinned to the anchor. The rod end of the cylinder is attached to the lift arm. Be sure the ports of the cylinder are up. Install the flow restrictor into the port on the base end of the hydraulic cylinder.

Bolt the two lift links to the lift arm using the 1" x 4-1/2" long bolt and locknut. Place flat washers between the lift arm and each link. The links must be free to pivot.

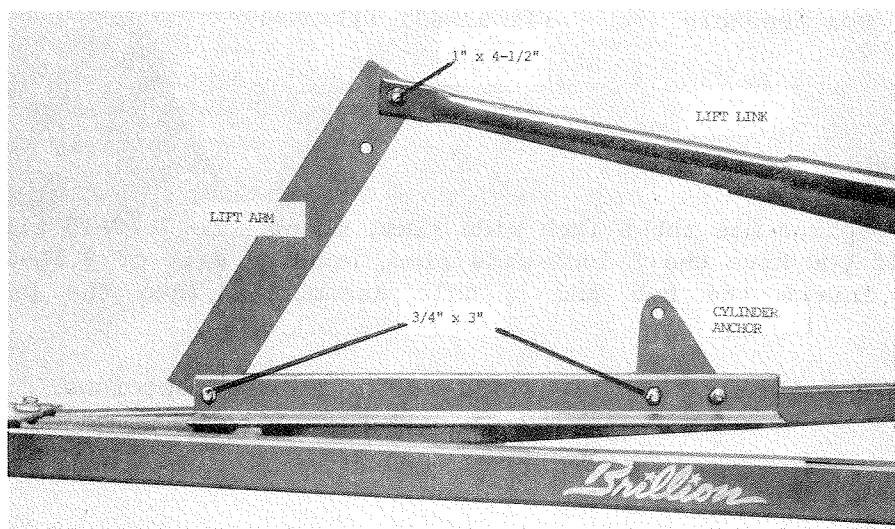

4. Attach the Center Frame

Use two 1" diameter x 6-5/16" long pins and 5/16" diameter x 1-1/2" roll pins to attach the center frame to the drawbar.

Raise or lower the center frame so that the lift links can be attached to the inside of the lugs welded to the center frame. Insert a pipe spacer into each link and bolt together with 3/4" x 2-1/2" long bolts (with hole drilled through the threaded end), slotted nuts, flat washers, and cotter pins.

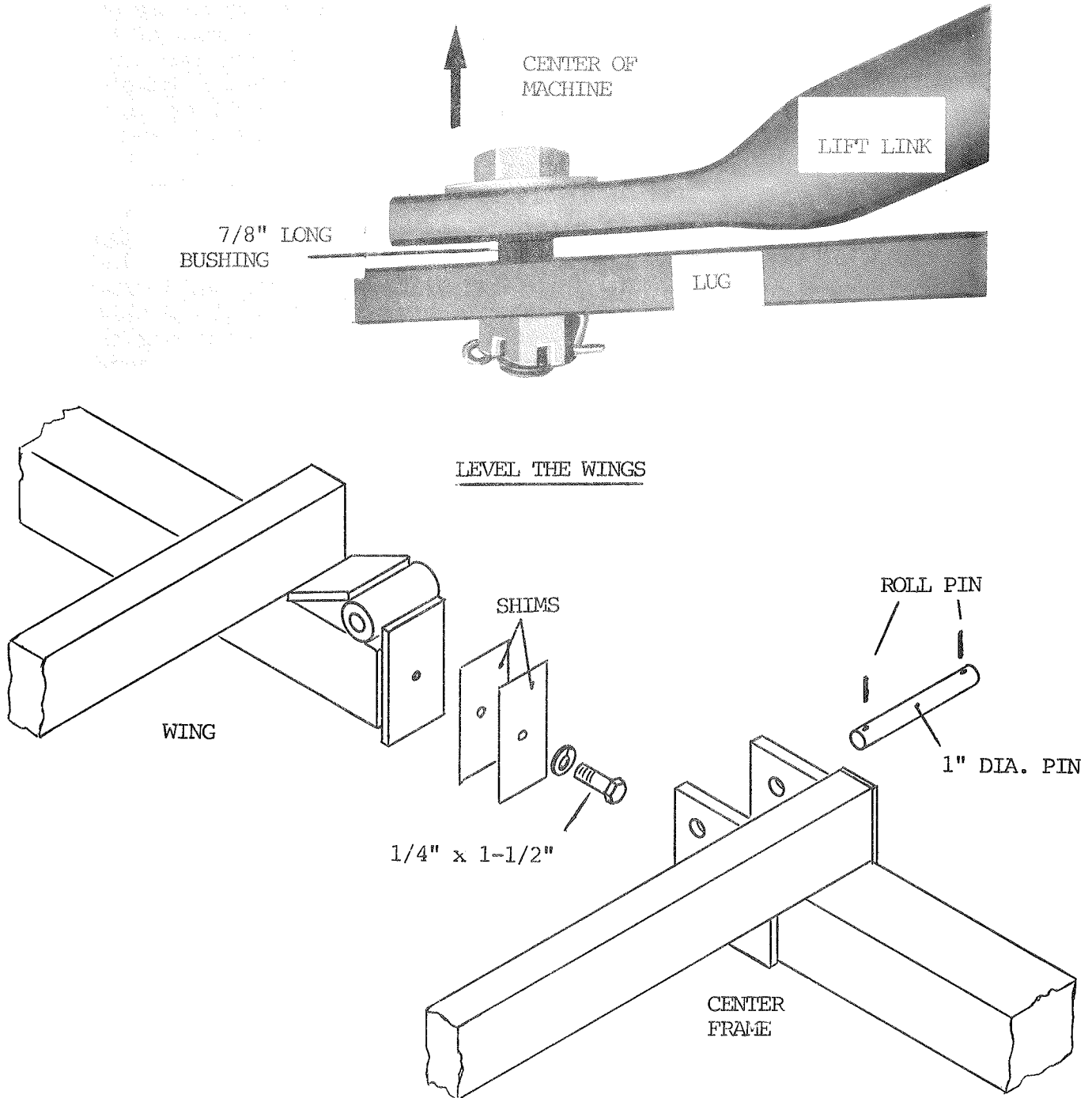

5. Attach the Wings

Pin the wings to the center frame with 1" diameter x 6-5/16" long pins in the front and 1" diameter by 4-1/2" long pins in the rear. Secure the pins with 5/16" x 1-1/2" long roll pins.

6. Level the Wings

The outside end of the wings must operate at the same height above the ground as the center section. To raise the wings, bolt the required amount of shims to the plate on the front tube of each wing. Two different thicknesses of shims are provided.

7. Assemble the Tooth Bars to the Skids

Arrange three skids approximately 3 or 4 feet apart depending on whether you are assembling 6 foot or 8 foot sections. Start with the front of the left skid. Insert a 1/2" x 1-3/4" long capscrew through the front triangular bracket on the skid. Place one of the 7/8" outside diameter (O.D.) x 5/8" long bushing over the bolt. Then place the lug of the tooth bar over the bushing. Next install one of the 17/32" inside diameter x 1-1/4" O.D. x 3/16" thick washer on the bolt and secure with a 1/2" locknut.

Now assemble two tooth bars to the front bracket of the middle skid. Place one of the 3/16" thick washers and a 7/8" O.D. bushing on a 1/2" x 2-3/4" long capscrew. Extend this through the lug on the tooth bar and through the bracket on the skid. Now place another bushing over the bolt and slide the second tooth bar over the bushing. Place a 3/16" thick washer over the bolt and secure with a 1/2" locknut. Assemble the right skid to the tooth bar in the same manner as the left.

Next, mount a tooth bar to the middle bracket of the left skid. Place a 3/16" thick washer and 1 7/8" O.D. bushing on a 1/2" x 2-3/4" long capscrew, then extend the bushing through the large hole of a 5J-448 strap. Insert the bolt through the bracket on the skid, place a bushing over the bolt, and slide another strap over the bushing. Then, mount a tooth bar lug over the bushing and secure with a 3/16" thick washer and a 1/2" locknut.

Now, assemble two tooth bars to the middle bracket of the center skid. Place a 3/16" thick washer and a bushing on a 1/2" x 2-3/4" capscrew. Extend the bushing through the tooth bar lug and through the large hole of a 5J-448 strap. Extend the bolt through the bracket on the skid. Place a bushing over the bolt and another strap over the bushing. Mount the lug of the next tooth bar over the bushing and place a 3/16" thick washer over the bolt and fasten with a 1/2" locknut.

Assemble the tooth bar to the right skid in the same manner as the left side.

Attach a chain between each pair of straps. Extend a 3/8" x 1-1/2" capscrew through the small hole on one of the straps, then through the end link of the chain, and through the other strap. Tighten with a 3/8" locknut so that the chain does not bind.

The rear tooth bars are attached to the skids in the same manner as the front row.

When assembling sections for a 4 foot wing, follow the instructions for the two outside skids.

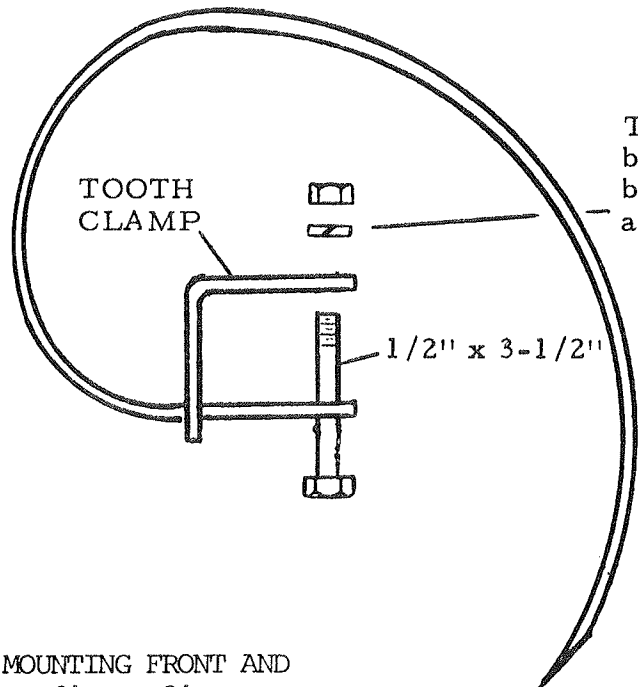

To minimize damage to bolt threads, install the bolt with the lockwasher and nut next to the clamp.

ASSEMBLY INSTRUCTIONS FOR MOUNTING FRONT AND REAR TOOTH BARS TO SKIDS FOR 6' AND 8' SECTIONS

(NOTE: FOR 4' SECTION, FOLLOW INSTRUCTIONS FOR THE TWO OUTSIDE SKID ANGLES.)

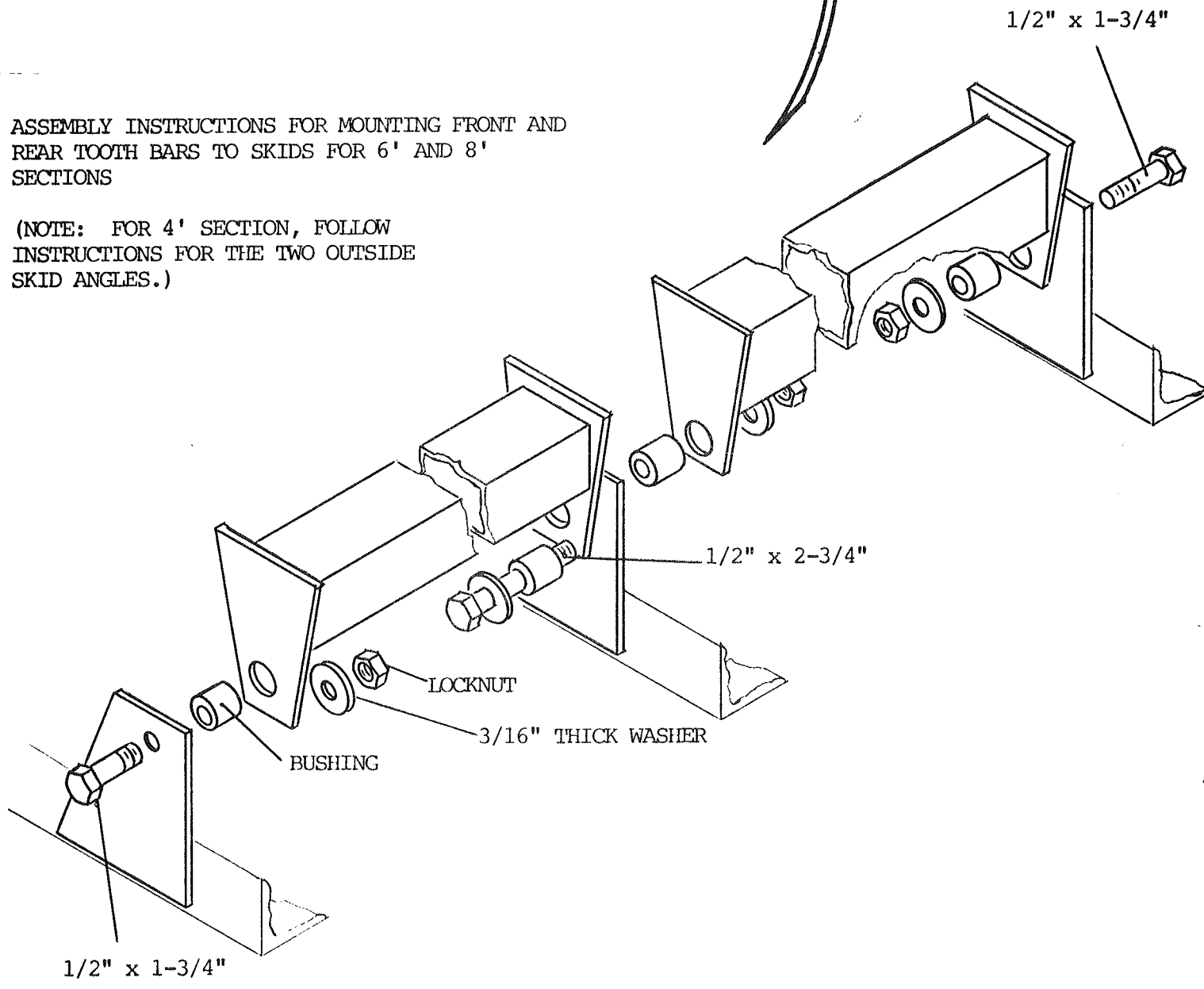

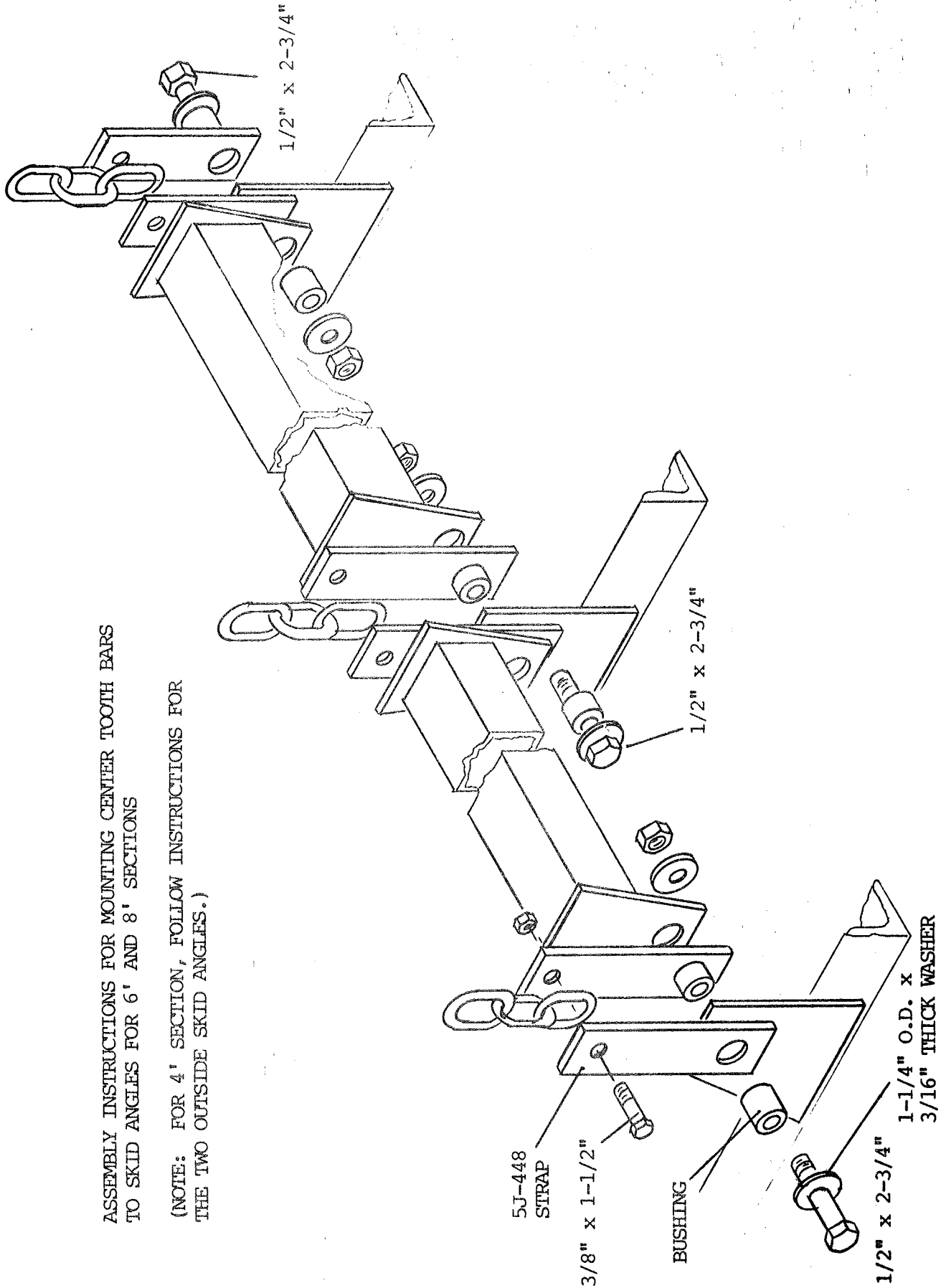

ASSEMBLY INSTRUCTIONS FOR MOUNTING CENTER TOOTH BARS
TO SKID ANGLES FOR 6' AND 8' SECTIONS

(NOTE: FOR 4' SECTION, FOLLOW INSTRUCTIONS FOR
THE TWO OUTSIDE SKID ANGLES.)

5J-448
STRAP

3/8" x 1-1/2"

BUSHING

1/2" x 2-3/4"

1-1/4" O.D. x
3/16" THICK WASHER

1/2" x 2-3/4"

1/2" x 2-3/4"

8. Mount the Teeth on the Tooth Bars

The teeth are mounted to the tooth bar using the clamp and a 1/2" x 3-1/2" long bolt, lockwasher and nut as shown.

Mount a tooth as far to the left as possible on the rear tooth bar. Then mount a tooth every 12 inches on that tooth bar.

Center a tooth 5-3/4" from the outside of the left end of the middle tooth bar. Then mount a tooth every 12 inches.

Center a tooth 9-3/4" from the left end of the front tooth bar. Then mount a tooth every 12 inches. The spacing on the right end of the tooth bar will be less than 12 inches. Mount this tooth as far to the right as possible.

9. Attach Levers to the Tooth Bars

Bolt a quadrant to each control tie bar with two 1/2" x 1-3/4" capscrews and locknuts. Extend a 1/2" x 1-3/4" long capscrew through the bottom hole of a bracket, then through the bottom hole of the lever and then through a second bracket. The brackets must face in opposite directions as shown. fasten a locknut loosely to the bolt so that the brackets can be rotated while aligning the top holes. Tighten this nut later.

Clip the lock rod of the lever into a notch on the quadrant. Extend a 1/2" x 2-1/4" long capscrew with a 1/2" washer through the large hole of the bracket then through the lever, and then through the second bracket and the tie bar. Place a bushing over the bolt where it extends through the tie bar and the bracket. Place a 1/2" washer and a locknut on the capscrew and tighten just enough to hold the bushing in place.

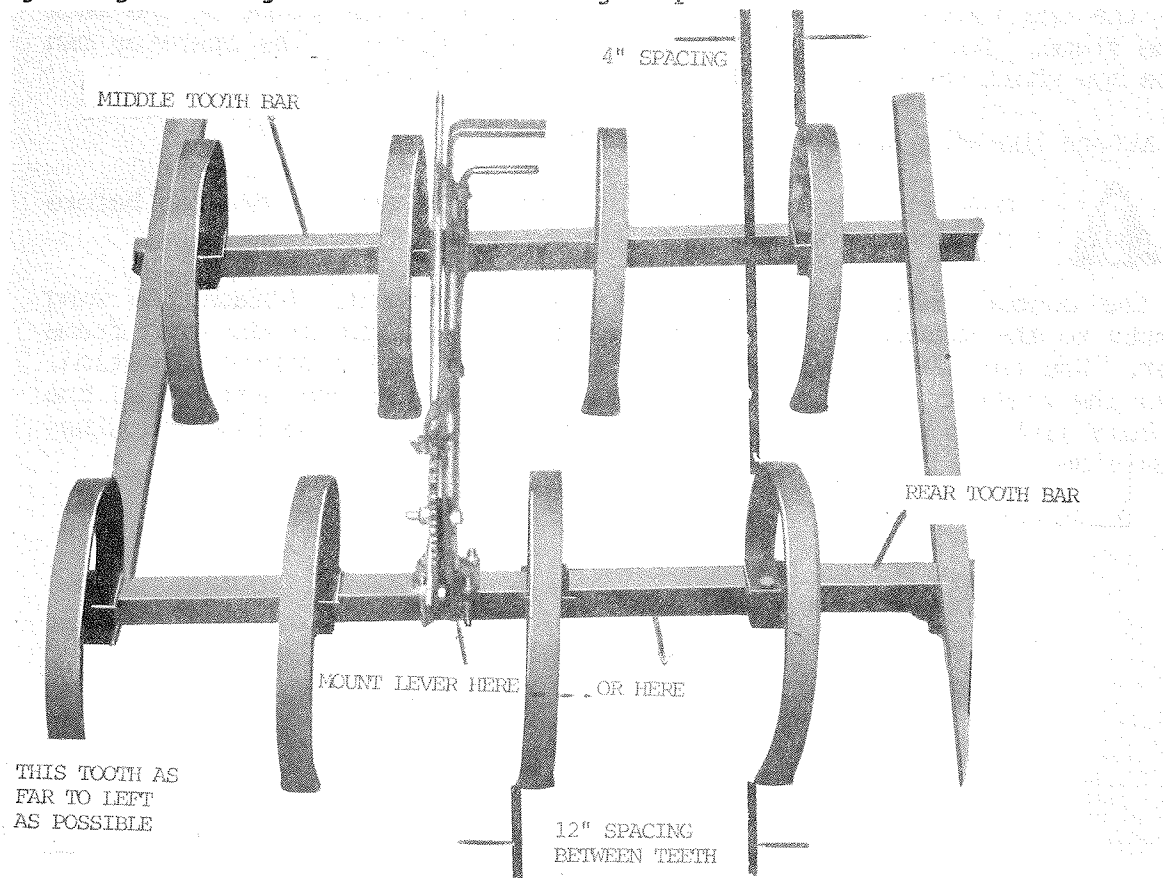

Attach the brackets loosely to the rear tooth bar midway between two teeth near the center of the tooth bar. Fasten with U-bolts, lockwashers and nuts. Attach the tie bar to the remaining tooth bars. Place a 1/2" washer and a bushing on a 1/2" x 1-3/4" capscrew. Extend the bolt and bushing through the bracket and the tie bar and secure with a 1/2" washer and a locknut. Fasten the brackets to the tooth bars with U-bolts. Tighten all the nuts which were previously left loose.

10. Attach the Skid Assemblies to the Frame

Line the skid assemblies up and back the center section and wings over the skids so that the tabs on the bottom of the frame are directly above the plates on the front of the skid angles.

(NOTE: See the section on Adjustments to determine which holes to fasten the 5J-449 straps to.)

Place a 5/8" bushing in the lower hole of the skid plate. Bolt a 5J-449 strap to each end of this bushing, as shown, using a 1/2" x 2-1/4" capscrew. Fasten a 1/2" locknut loosely to this bolt. Bolt the straps to the desired hole in the tab on the underside of the frame. Note that if you are using the bottom hole of the tab, use the middle hole of the pull strap. If you are using the top hole of the tab, use the end hole of the strap. A bushing is always placed in the hole in the tab. A 1/2" x 2-1/4" capscrew is placed through the unused hole in the straps. This bolt acts as a stop when the machine is picked up.

Place the end link of the chain through the slot in the plate on the back of the frame. Hold the chain in place with a klik pin. The operator can choose how short the chain should be attached for field conditions.

11. Attach the Wing Brackets to the Drawbar



Danger! Harrow must be attached to a tractor drawbar before raising center frame.

Fold the center frame up and swing the wings forward. Attach the wing brackets to the drawbar so that the bracket is centered on the wing frame member. Use the 5/8" washers to shim the bracket to its correct location. Fasten the bracket with 5/8" x 7" bolts, lockwashers and nuts. Use the 5/8" bolt with the hole drilled in and the hair pin clip to lock the wings in position.

