

OPERATOR'S MANUAL



SPRING TINE HARROW

MODELS: STS-8, STS-10,
STS-12, STS-3, STS-4

SPRING TOOTH HARROW

MODELS: STR-8, STR-10,
STR-12, STR-3, STR-4



BRILLION IRON WORKS
BRILLION, WISCONSIN 54110

INTRODUCTION

Your Brillion Spring Tine Harrow is built with the best materials and workmanship available. Proper care and operation will insure that you receive the service and long life built into this machine.

Study this manual carefully before attempting to assemble or operate this machine. A special section of this manual is devoted to assembly of this machine. Refer to the "Setting Up Instructions" and "Operating Instructions" portion of this manual.

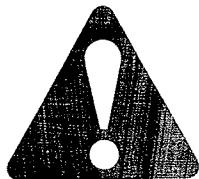

This safety alert symbol identifies important safety messages in this manual. When you see this symbol, be alert to the possibility of personal injuries and carefully read the message that follows.

LOCATION REFERENCE

"Right" and "Left", "Front" and "Rear" refer to the operators "Right" and "Left", "Front" and "Rear" when he faces in the same direction as the machine will travel.

SAFETY INSTRUCTIONS



CAUTION: Lower wings with caution - don't drop. Keep hands away from hinge area when lowering wings. Keep all bystanders away from harrow when lowering wings.



CAUTION: The tractor drawbar must be locked into a fixed position when transporting the harrow.



CAUTION: This harrow has been designed to be transported at a speed of 20 m.p.h. **DO NOT EXCEED.** When transporting, slow down when traveling over rough and bumpy ground.



CAUTION: When transporting the harrow on a road or highway use adequate warning symbols, reflectors and lights as required.

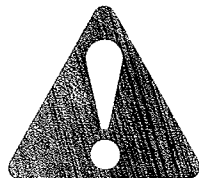

SAFETY RULES

Do not grease, oil or adjust the harrow while it is in motion.

Never permit any person other than the operator on the tractor.

Never ride or permit others to ride on the harrow.

Park or block the harrow so it will not roll when disconnected from the tractor.

Securely block the harrow so it will not tip or roll before working on it.

OPERATING INSTRUCTIONS

TRANSPORTING THE HARROW

A standard 8" stroke agricultural cylinder is required for lifting the harrow for transport. Raise the harrow for transport by extending the hydraulic cylinder to its full length. At this time, fold the wings into reduce the overall width for traveling.



Do not transport at speeds exceeding 20 M.P.H. Connect the depth control links into transport position before transporting, see Figure 1.

DEPTH CONTROL

Working depth is controlled by the hydraulic cylinder from the tractor and the four links fastened to the mating lugs on the axle lift arm and the center frame. These links are preset to any desired work depth with the connecting clevis pin. See link hole positioning chart on Figure 1. Raise the harrow to transport position to change the clevis pin hole settings.

In field operation, the hydraulic cylinder is retracted until the links tighten to hold the axle firmly in position. When it is necessary to raise the harrow for turning or dumping trash, the hydraulic cylinder is extended. This allows the links to fold down between the middle and rear tooth bars. When returning to work position, the hydraulic cylinder is retracted. The harrow lowers and the links then become tight which automatically maintains the same working depth. After the working depth is determined, the harrow is leveled by adjusting the drawbar clevis in the drawbar hitch.

OPERATING

The harrow should be raised when making short turns, such as at the ends of the field. Failure to raise the harrow out of the ground when turning short, places excess strain on the teeth, and may result in premature tooth failure.



Keep all bystanders away from the harrow when raising and lowering the unit from field to transport positions.

LUBRICATION

Coat the inner surfaces of the transport axle bearings and bearing clamps with grease before assembling. Grease daily when in use. Repack wheel bearings once per season with a good grade of wheel bearing grease.

IDENTIFICATION OF CAPSCREW GRADES



Grade 2



Grade 5



Grade 8

SETTING-UP INSTRUCTIONS

NOTE: REFER TO REPAIR PARTS CATALOG FOR IDENTIFICATION OF PARTS AND FOR THE RELATIONSHIP OF THE PARTS PUT TOGETHER.

SHIPPING BUNDLE CHECK LIST

Your Brillion Model STS Spring Tine Harrow is shipped to you in separate assemblies. These assemblies are:

<u>Assembly Name</u>	<u>Number Used On</u>				
	<u>STS-8</u>	<u>STS-10</u>	<u>STS-12</u>	<u>STS-3</u>	<u>STS-4</u>
Center Frame	1	1	1		
Axle	1	1	1		
Drawbar	1	1	1		
Frame Angle Bundles	2	2	2		
Wheels	2	2	2		
Bags and/or Box Assemblies	3	3	3	3	3
Spring Tines	25	31	37	16	22
Wing Frames				2	2

ASSEMBLY OF MAIN FRAME & AXLE

Begin by placing the center frame in the upside down position so the hinge brackets are facing downward. Block up the four corners so the toothbars are 12" off the floor. Place the four 2J-252 bearing assemblies over the mating holes on the front to back frame angles. The two outer bearing assemblies must have the lube fitting facing inward. The two inner bearing assemblies must have the lube fitting facing outward.

Position the axle over the center frame onto the bearing assemblies with the lift arm pointing downward between the middle pair of front to back frame angles. Fasten the axle to the 2J-252 bearing assemblies and frame angles with the 3D-543 bearing clamps, 1/2" x 1-3/4" long Grade 5 capscrews, lockwashers, and locknuts. Insert the capscrews with the lockwashers and nuts adjacent to the frame angles. See Figure 1.

Mount the wheels on the wheel hubs, using the wheel bolts provided. Use 6:70 x 15" or 7:60 x 15", 4 ply rib implement tires or equivalent.

Now turn the harrow around into the upright position and block it up at the four corners.

ASSEMBLY OF DRAWBAR AND BRACE ANGLES

Bolt the drawbar to the center frame plate with the 5/8 x 1-3/4 long Grade 5 capscrews, lockwashers, and locknuts. Do not tighten capscrews until drawbar braces are attached. Attach the 2J-312 and 2J-313 inner brace angles to the rear holes of the drawbar plate using 5/8 x 1-3/4 long Grade 5 capscrews, lockwashers, and locknuts. Fasten these angles to the center frame toothbars using six 5C-78 straps, 1/2 x 3-1/2 long Grade 5 capscrews, lockwashers, and locknuts. See Figure 4 for correct position of these angles on the toothbars. The same inner (Straight) braces are used on the 8 foot, 10 foot and 12 foot center frames.

SIDE VIEW OF DRAWBAR, CENTER FRAME, AXLE,
AND DEPTH CONTROL LINK ASSEMBLY

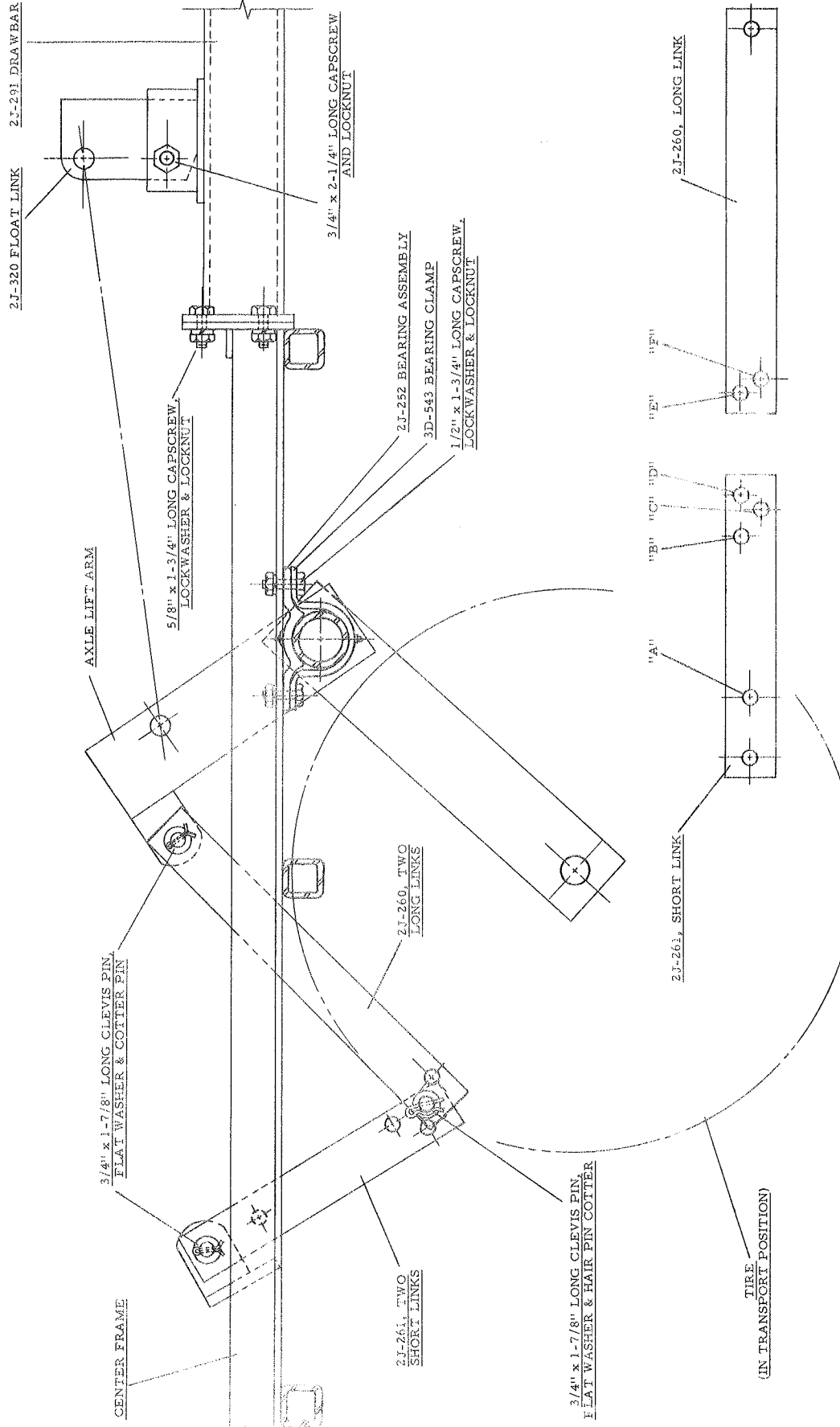

LINK HOLE POSITIONS					
TRANSPORT POSITION	WORK DEPTH	WORK DEPTH	WORK DEPTH	WORK DEPTH	WORK DEPTH
2J-261 SHORT LINK	"A"	"D"	"C"	"B"	"E"
2J-260 LONG LINK	"E"	"E"	"E"	"E"	"E"

FIGURE 1

ON THE 8 FOOT CENTER FRAME, attach the 2J-318 and 2J-319 outer braces to the front toothbars, between the hinge bracket and the diagonal straps. See Figure 6. Use the two 5C-78 straps, 1/2 x 3-1/2 long Grade 5 capscrews, lockwashers, and locknuts to fasten the braces to the toothbar. The drawbar end of these braces are bolted to the front holes in the drawbar plate. The right hand brace is secured with a 5/8 x 1-3/4 long Grade 5 capscrew, lockwasher, and locknut. On the left hand side, use the 5/8 x 2-1/4 long Grade 5 capscrew, 5/8 flat washer, lockwasher and locknut which also clamps the 6D-333 hose support in place.

Now tighten all drawbar and brace angle capscrews securely.

ON THE 10 FOOT CENTER FRAME, attach the outer 2J-316 and 2J-317 brace angles to the short, diagonal frame angles on the center frame. Fasten with 5/8 x 1-3/4 long Grade 5 capscrews, lockwashers, and locknuts. The drawbar end of these braces are attached the same as on the 8 foot center frame.

ON THE 12 FOOT CENTER FRAME, attach the outer 2J-314 and 2J-315 brace angles to the short, diagonal frame angles on the center frame. Fasten with 5/8 x 1-3/4 long Grade 5 capscrews, lockwashers, and locknuts. The drawbar end of these braces are attached the same as on the 8 foot center frame.

HITCH CLEVIS AND FLOAT LINK ASSEMBLY

Bolt the 2D-349 clevis assembly to the middle hole in the drawbar bracket with the 3/4 x 5 long Grade 5 capscrew and locknut. Fasten the 2J-320 float link to the top side of the drawbar as shown in Figure 1. The large hole is positioned up and toward the center frame. Fasten with the 3/4 x 2-1/4 long Grade 5 capscrew and locknut. Do not draw nut up tight but leave just enough looseness to permit the float link to swing freely.

DEPTH CONTROL LINK ASSEMBLY

Assemble the two 2J-261 short links (15" long) to the anchor lug located between the middle frame angles near the rear toothbar of the center frame. Attach with the 2D-473 clevis pin, 3/4 flat washer and 1/8 x 1-1/2 long cotter pin. Fasten the two 2J-260 long links (20" long) to the anchor lug located on the axle lift arm in the same manner. See Figure 1 for the correct position of these links. Join the four links together with the third 2D-473 clevis pin, 3/4 flat washer, and hair pin cotter.

WING TO CENTER FRAME ASSEMBLY

Mount the wing frames to the center frame, using the 2J-256 clevis pins, 3/4" flat washers and 1/8 x 1-1/2 long cotter pins. Insert the clevis pins so the washer and cotter pin are toward the center of the machine. BOTH WINGS ARE IDENTICAL IN DESIGN TO ELIMINATE THE LEFT HAND AND RIGHT HAND PLACEMENT OF THEM. See Figure 3 and 7.

SPRING TINE ASSEMBLY

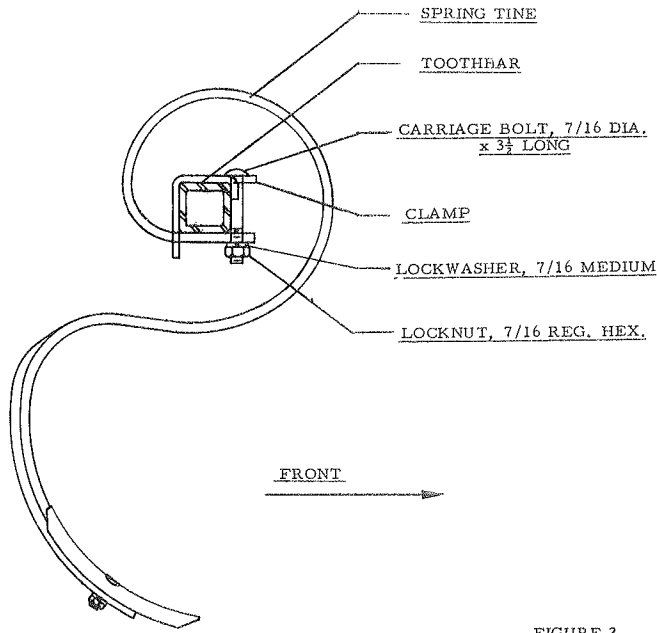

FIGURE 2

SPRING TOOTH ASSEMBLY

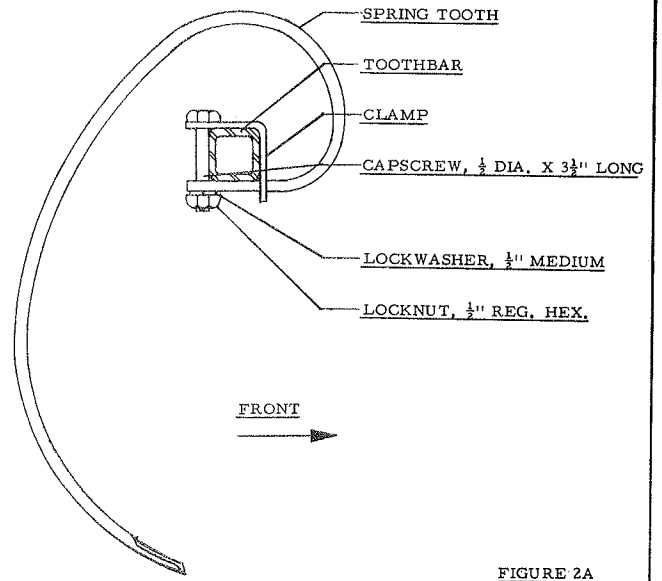
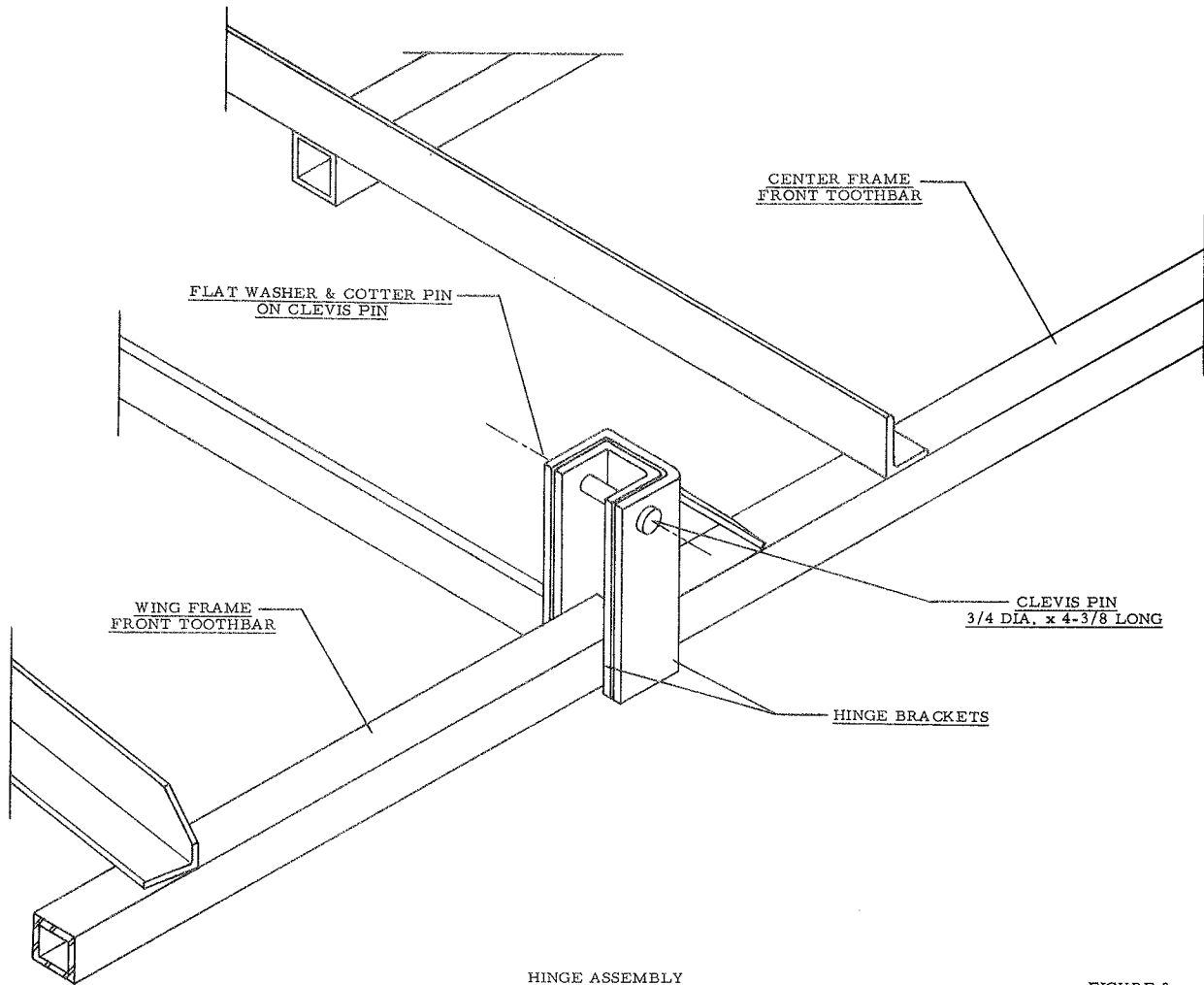

FIGURE 2A



HINGE ASSEMBLY
(WING FRAME TO CENTER FRAME)

FIGURE 3

ON THE 3 FOOT WINGS, attach the 6D-342 support springs to the outer corners of the front toothbar. Use the 5D-836 black tooth clamp, 1/2 x 3-1/2 long Grade 5 capscrew, lockwasher, and locknut. Bolt the 2D-360 skid to the support spring with the 3/8 x 1-1/2 long plow bolts, lockwashers and nuts. See page 4 of repair parts catalog and Figure 7.

ON THE 4 FOOT WINGS, attach the 6D-343 support springs to the outer corners of the front toothbar. Use the 5D-838 red tooth clamp, 1/2 x 3-1/2 long Grade 5 capscrew, lockwasher, and locknut. Bolt the 2D-864 skid to the support spring with the 3/8 x 1-1/2 long plow bolts, lockwashers and nuts. See page 4 of repair parts catalog and Figure 7.

SPRING TINE ASSEMBLY

Attach the spring tines to the toothbars at the points indicated on the following pages. Use the 1J-834 clamps, 7/16 x 3-1/2 long Grade 5 carriage bolts, lockwashers, and locknuts. See Figure 2.

SPRING TOOTH ASSEMBLY

Attach the spring teeth to the tooth bars at the points indicated on the following pages. Use the 5D-836 clamps, 1/2 x 3-1/2 long Grade 5 capscrews, lockwashers, and locknuts. See Figure 2A. Refer to Page 4 for the remainder of assembly instructions.

SHIPPING BUNDLE CHECK LIST FOR STR MODELS

Your Brillion Model STR Spring Tooth Harrow is shipped to you in separate assemblies. These assemblies are:

<u>Assembly Name</u>	<u>Number Used On</u>				
	<u>STR-8</u>	<u>STR-10</u>	<u>STR-12</u>	<u>STR-3</u>	<u>STR-4</u>
Center Frame	1	1	1		
Axle	1	1	1		
Drawbar	1	1	1		
Frame Angle Bundles	2	2	2		
Wheels	2	2	2		
Bags and/or Box Assemblies	2	2	2	2	2
Spring Teeth	25	31	37	16	22
Wing Frames				2	2

OPTIONAL EQUIPMENT

<u>Part No.</u>	<u>Description</u>	<u>Weight</u>
5D-918	3' Spike Tooth Rear Smoothener Section, 4" Spacing	49.0#
5D-919	4' Spike Tooth Rear Smoothener Section, 4" Spacing	58.0#
2J-149	1-3/8" Heavy Duty Reversible Point With Attaching Hardware	1.0#
2J-615	Drawbar Jack Kit	13.0#

GENERAL SPECIFICATIONS

<u>Model No.</u>	<u>Name</u>	<u>Description</u>
STS-8	8 Foot Spring Tine Harrow	Includes one 8 foot center frame and all mating parts to make-up a 8 foot wide working unit.
STR-8	8 Foot Spring Tooth Harrow	
STS-10	10 Foot Spring Tine Harrow	Includes one 10 foot center frame and all mating parts to make-up a 10 foot wide working unit.
STR-10	10 Foot Spring Tooth Harrow	
STS-12	12 Foot Spring Tine Harrow	Includes one 12 foot center frame and all mating parts to make-up a 12 foot wide working unit.
STR-12	12 Foot Spring Tooth Harrow	
STS-3 STR-3	3 Foot Wing Kit	Includes two 3 foot wing frames, hinge pins, skids and all mating parts for the wing kit.
STS-4 STR-4	4 Foot Wing Kit	
Tines - - - - - 3/8 x 1-1/4 Heat Treated Alloy Spring Steel		
Teeth - - - - - 3/8 x 1-3/4 Heat Treated Alloy Spring Steel		
Spacing - - - - - 4"		
Working Depth - - - - - 1" to 5" - Controlled by Hydraulic Cylinder From Tractor and Preset Depth Control Links on Harrow.		
Transport Clearance - - - - - 8"		
Transport Wheels - - - - - 15"-4 Bolt (Standard); 14"-4 Bolt (Optional)		
Wheel Bearings- - - - - Tapered Roller		

NOTE: The STS Models Use The "S" Shaped Spring Tines. The STR Models Use The Conventional "C" Shaped Rigid Teeth.

STS SERIES 8 TO 20 FOOT WIDTHS

<u>Model No.</u>	<u>Nominal Working Width</u>	<u>Field Position O. A. Width</u>	<u>Transport Position O. A. Width</u>	<u>Number of Teeth Used</u>
STS-8	8 Feet	9 Ft. 1 In.	9 Ft. 1 In.	25
STS-10	10 Feet	11 Ft. 1 In.	11 Ft. 1 In.	31
STS-12	12 Feet	13 Ft. 1 In.	13 Ft. 1 In.	37
(1)STS-8 & (1)STS-3	14 Feet	14 Ft. 4 $\frac{1}{4}$ In.	9 Ft. 1 In.	41
(1)STS-10 & (1)STS-3	16 Feet	16 Ft. 4 $\frac{1}{4}$ In.	11 Ft. 1 In.	47
(1)STS-10 & (1)STS-4	18 Feet	18 Ft. 4 $\frac{1}{4}$ In.	11 Ft. 1 In.	53
(1)STS-12 & (1)STS-4	20 Feet	20 Ft. 4 $\frac{1}{4}$ In.	13 Ft. 1 In.	59

STR SERIES 8 TO 20 FOOT WIDTHS

<u>Model No.</u>	<u>Nominal Working Width</u>	<u>Field Position O. A. Width</u>	<u>Transport Position O. A. Width</u>	<u>Number of Teeth Used</u>
STR-8	8 Feet	9 Ft. 1 In.	9 Ft. 1 In.	25
STR-10	10 Feet	11 Ft. 1 In.	11 Ft. 1 In.	31
STR-12	12 Feet	13 Ft. 1 In.	13 Ft. 1 In.	37
(1)STR-8 & (1)STR-3	14 Feet	14 Ft. 1 $\frac{1}{4}$ In.	9 Ft. 1 In.	41
(1)STR-10 & (1)STR-3	16 Feet	16 Ft. 4 $\frac{1}{4}$ In.	11 Ft. 1 In.	47
(1)STR-10 & (1)STR-4	18 Feet	18 Ft. 4 $\frac{1}{4}$ In.	11 Ft. 1 In.	53
(1)STR-12 & (1)STR-4	20 Feet	20 Ft. 4 $\frac{1}{4}$ In.	13 Ft. 1 In.	59

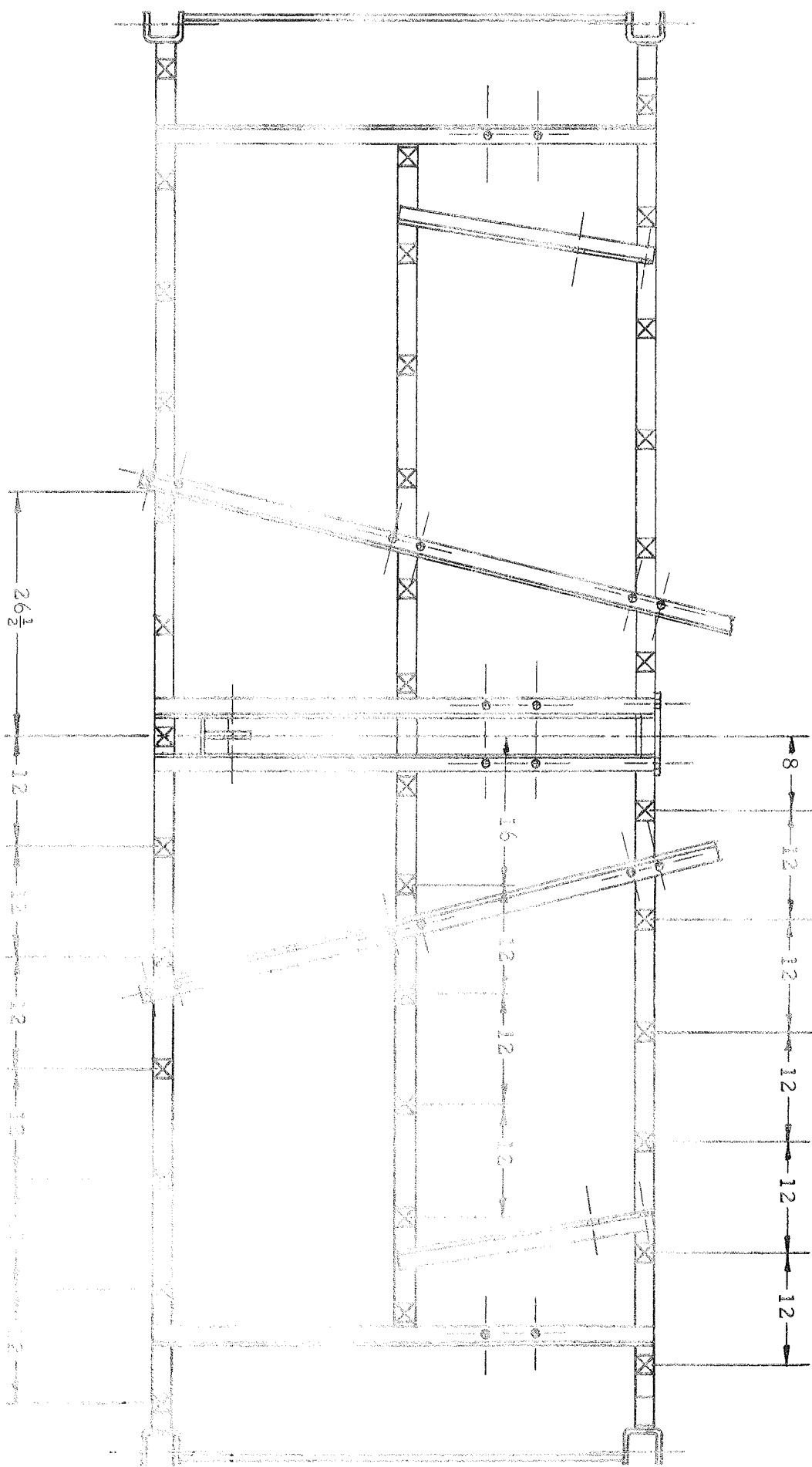

FIGURE 4

12 FOOT CENTER FRAME
 X 4 INCH TOOTH SPACING

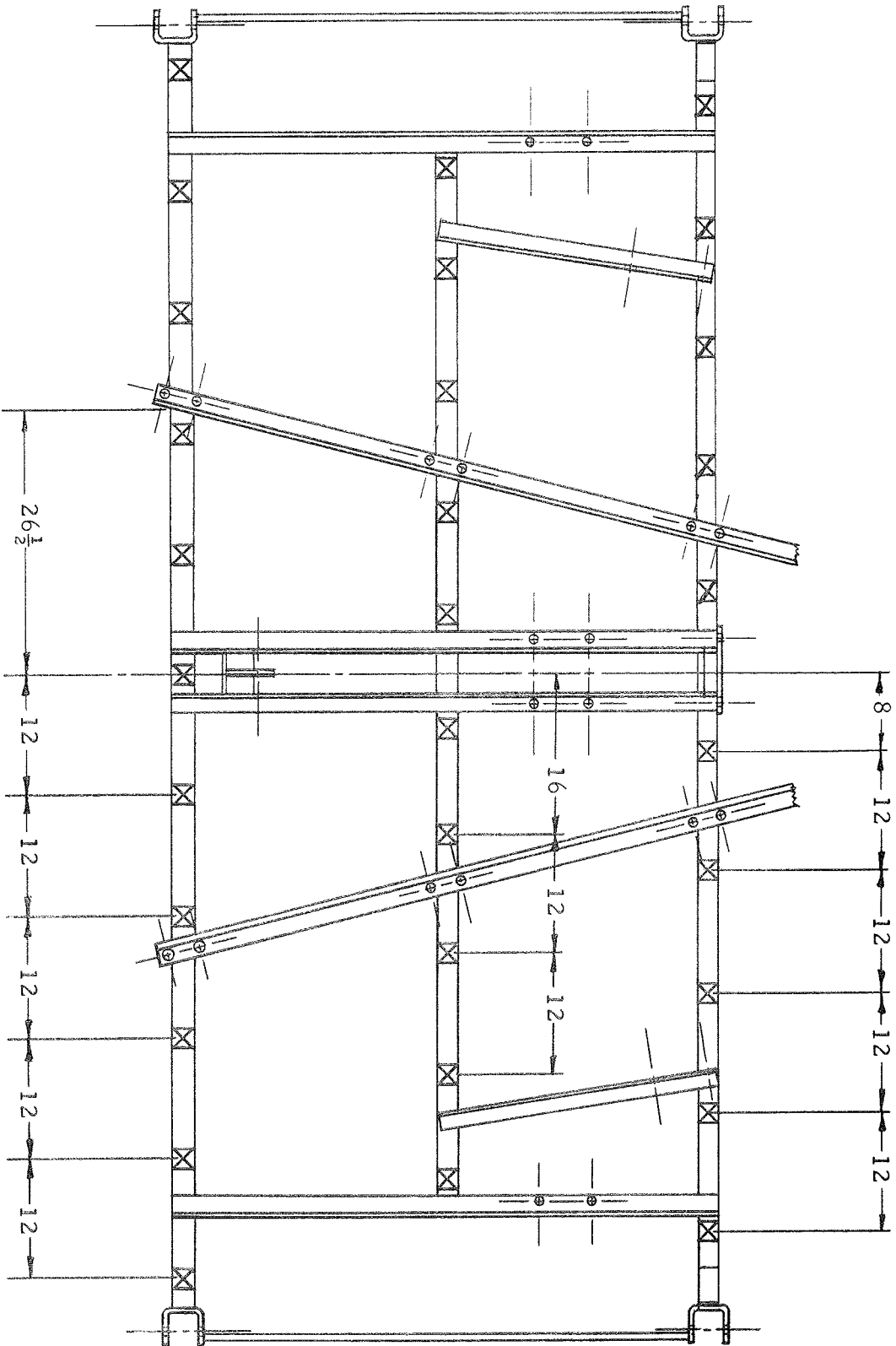

FIGURE 5

10 FOOT CENTER FRAME
 X 4 INCH TOOTH SPACING

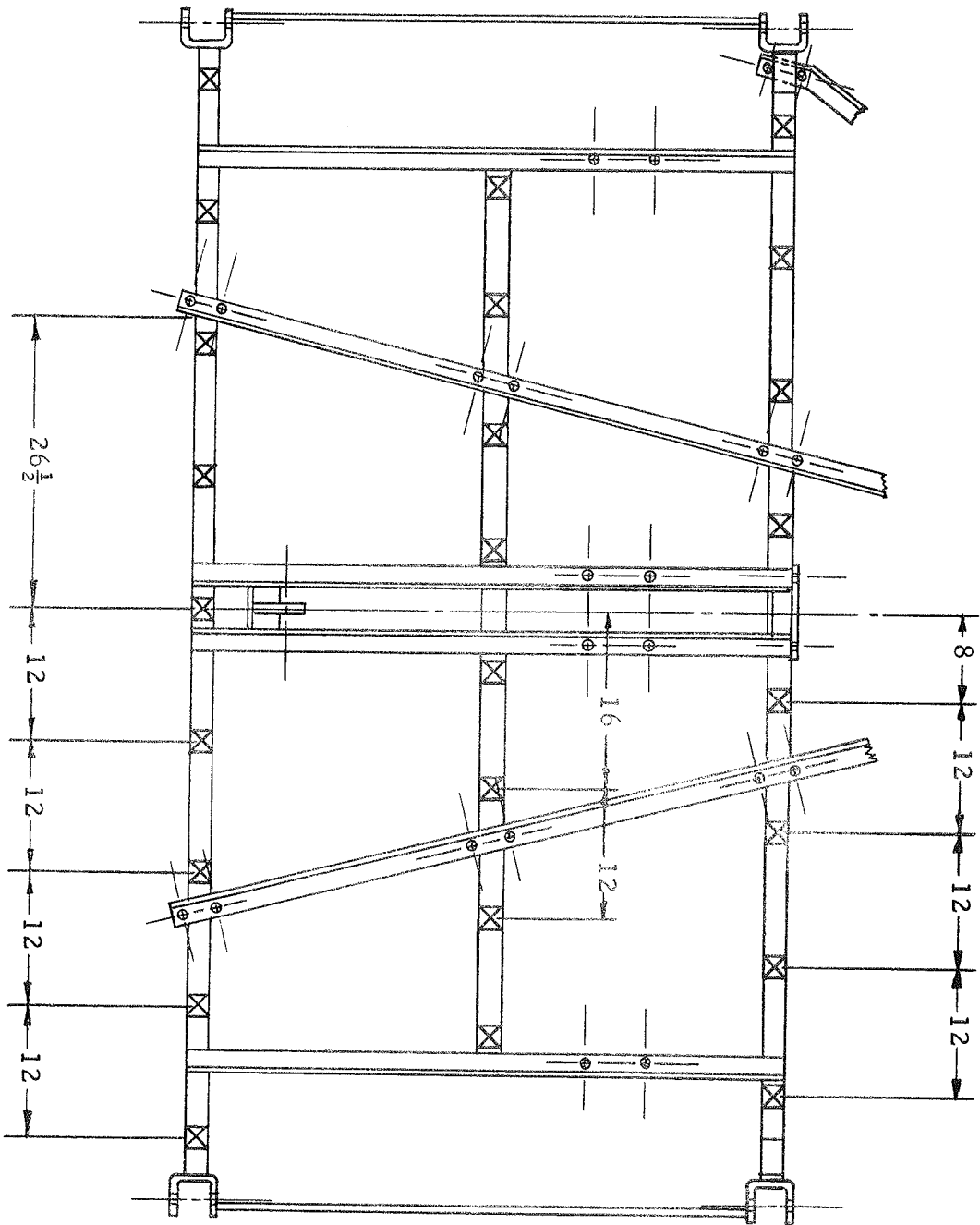
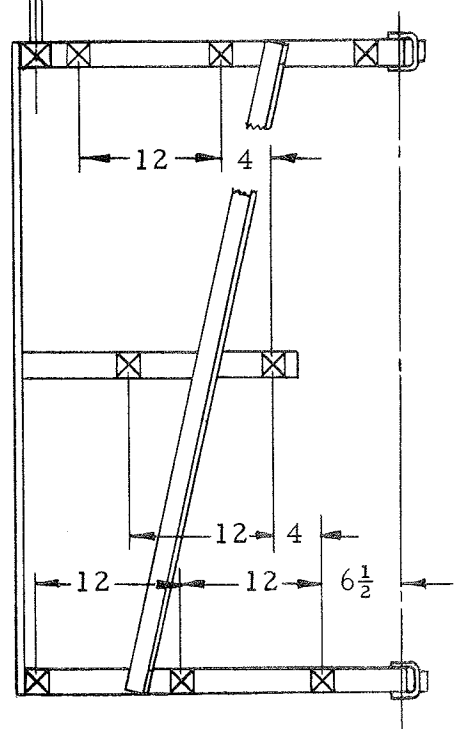

FIGURE 6

8 FOOT CENTER FRAME
 X 4 INCH TOOTH SPACING

SKID 3 FOOT WING FRAMES SKID
☒ 4 INCH TOOTH SPACING



↑
FRONT

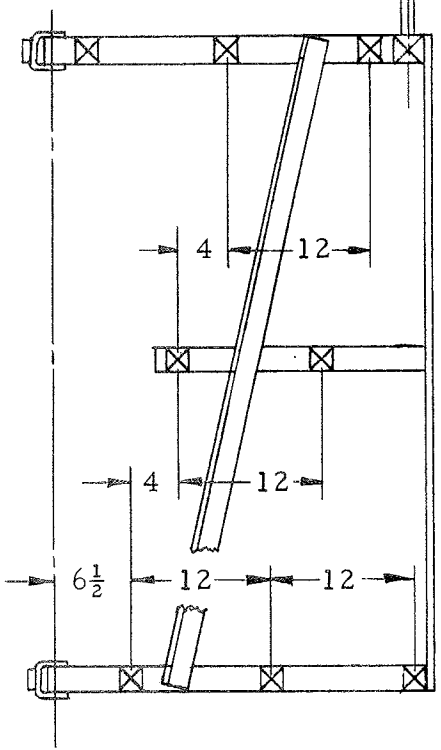

LEFT HAND
WING POSITION

RIGHT HAND
WING POSITION

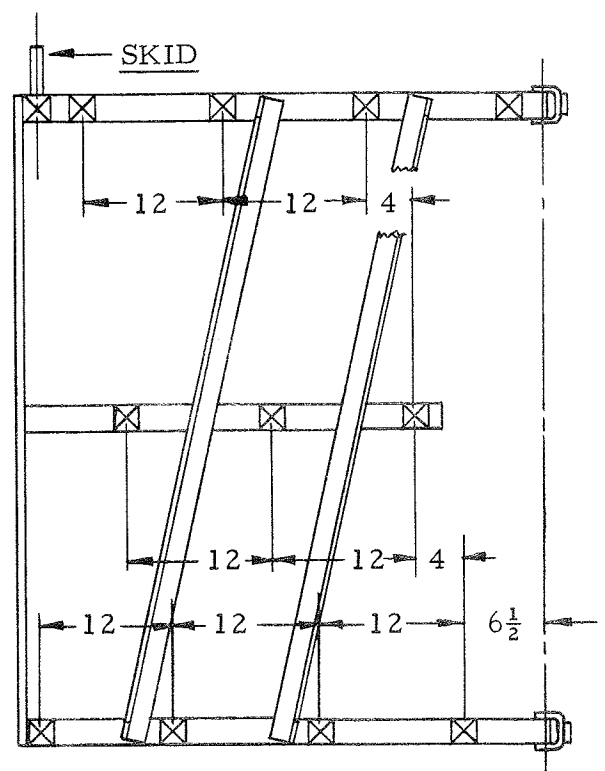

↑
FRONT

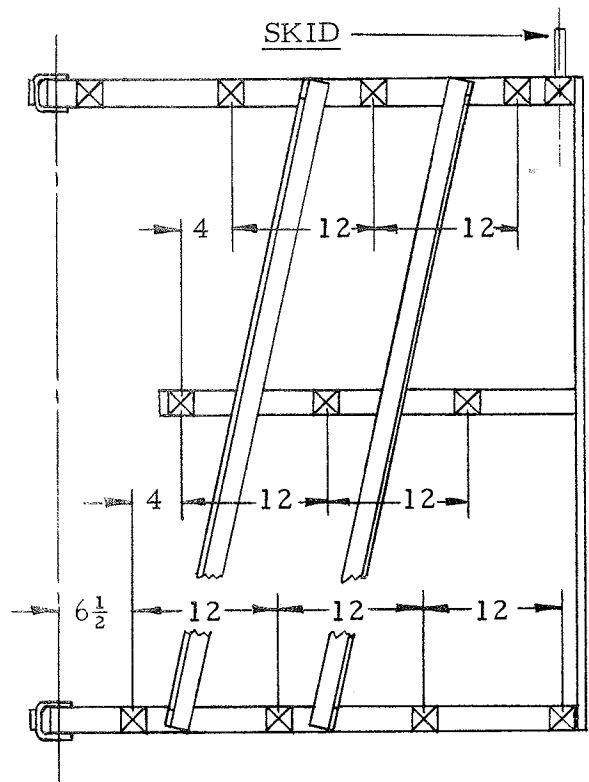

4 FOOT WING FRAMES
☒ 4 INCH TOOTH SPACING

FIGURE 7