

# OPERATOR'S MANUAL



# MOW SAFE MOWER

MODEL MSH 600-01

AND

MODEL MSH 720-01

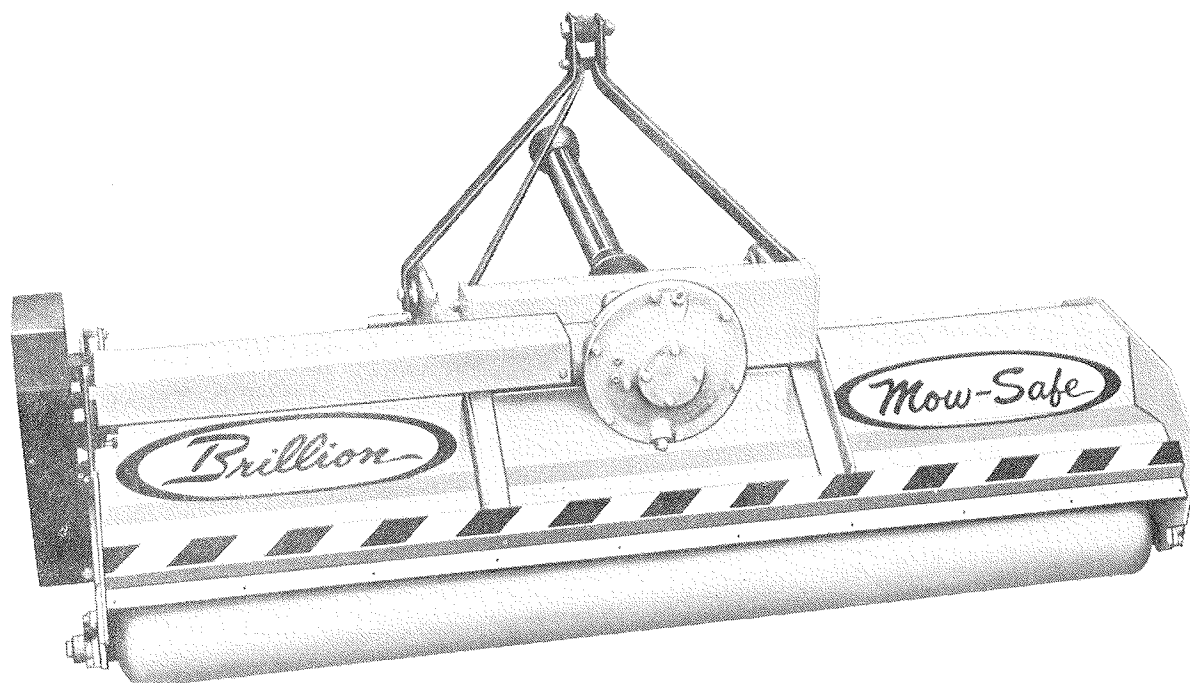

**BRILLION IRON WORKS, INC.**  
BRILLION, WISCONSIN 54110

## INTRODUCTION

Your Brillion Mow-Safe Mower is built with the best materials and workmanship available. It has been carefully designed and thoroughly tested to assure you of a machine which is simple and durable, safe and easy to operate, yet economical to own.

Used within its ratings and properly maintained, it will give years of satisfying, trouble-free service.

Study this manual carefully before attempting to assemble or operate the machine.

### SAFETY INSTRUCTIONS

1. DO NOT UNDER ANY CIRCUMSTANCES ALLOW ANYONE TO REMAIN IN VICINITY OF MACHINE WHEN STARTING & OPERATING.
2. OPERATOR MUST REMAIN ON TRACTOR WHILE POWER TAKE-OFF IS IN MOTION.
3. NEVER MAKE ADJUSTMENTS, LUBRICATE OR CLEAN MACHINE WITH ANY PART OF MACHINE IN MOTION.
4. KEEP ALL SHIELDS IN PLACE.
5. KEEP HANDS, FEET & CLOTHING AWAY FROM POWER-DRIVEN PARTS.
6. DO NOT PERMIT TRACTOR RIDERS OTHER THAN OPERATOR.
7. DO NOT ALLOW ANYONE TO RIDE THE MACHINE.
8. DO NOT OPERATE THE MOWER IN EXCESS OF STANDARD TRACTOR P.T.O. SPEED.
9. BLOCK UP MACHINE BEFORE ATTEMPTING SERVICE UNDER MACHINE. DO NOT RELY ON TRACTOR HYDRAULIC SYSTEM FOR SUPPORT WHILE SERVICING.
10. ALLOW THE ROTOR TO ATTAIN ITS FULL SPEED BEFORE ATTEMPTING TO CUT.

SPECIFICATIONS

Model No. - - - - - MSH-600  
MSH-720

Mounting - - - - - 3 Point Lift - Category I

Tractor P.T.O. - - - - - 540 RPM

Width of Cut - - - - - 59-5/8 inches (MSH-600)  
71-5/8 inches (MSH-720)

Overall Width - - - - - 67-1/4 inches (MSH-600)  
79-1/4 inches (MSH-720)

Height of Cut - - - - - Adjustable from 3/4 to 6 inches.  
1 to 9 inches with optional caster wheels.

Gear Box - - - - - Heavy duty, built by Brillion. Rated  
69 H.P. (based on tooth strength).

Gears - - - - - Heat treat alloy steel, machine cut -  
run in oil bath

Drive Ratio - - - - - 1 to 3.92 speed up

Rotor Speed at 540 P.T.O. - - - - - 2120 RPM

Knife Tip Speed - - - - - 7,100 ft./min. (80.5 MPH)

Knife Cutting Diameter - - - - - 12-3/4 inches

Knives - - - - - 14 Ga. (.083) x 3/4" wide standard.  
Heat treated steel - reversible,  
double edge

Bearings - - - - - Drive 1-1/8 dia., rotor 1-7/16 dia.  
Ball bearings - relubricatable

Belt - - - - - C-section V-belt, premium  
Reverse bend construction

Frame - - - - - Heavy gauge steel welded assembly

Weight - - - - - 475 pounds (MSH-600)  
560 pounds (MSH-720)  
550 pounds (MSH-600 with caster wheels)  
635 pounds (MSH-720 with caster wheels)

## OPTIONAL EQUIPMENT

Wheel Support Kit: Set of two 360° caster wheels with either 6½50 x 13 flotation terra-tires or 4 x 6 laminated tires.

Rear Trash Deflector: Additional protection against flying debris.

Rubber Roller Kit: Wear-resistant rubber on rear roller prevents damage to grave markers, water outlets, and other flush mounted ground installations.

Knives: Thatching, 14 ga. (.083) x 1-1/4 Wide

The thatching knife is used singly with a spacer washer rather than in pairs like the standard knives. Insert one thatching knife and one 5/16" flat washer into each slot of the hanger bars.

## ASSEMBLY INSTRUCTIONS

Your Brillion Mow-Safe mower is shipped to you in assemblies and bundles. Before starting to assemble the mower, separate the various bundles and take care not to lose any of the parts or hardware.

<u>Shipping Bundle</u>	<u>No. Used Per Machine</u>
Hood Assembly	1
P. T. O. Bundle	1
Box Assembly	1
End Shield	1
Top Shield	1
Cross Shaft	1

Note: Refer to figures and part names indicated in repair parts catalog. These figures will show the relative position of the parts to be assembled and also identify the fasteners used in joining these parts.

"Right" and "Left", "Front" and "Rear" are determined when the operator faces the direction the machine will travel, standing behind it.

Begin assembly with the machine in the upright position. Place a four or five inch block under the hood end plates to keep the knives from resting directly on the ground.

Before installing the drive pulley, place the three 2-1/4" O.D. x 1-1/2" I.D. machinery bushings over the left hand rotor stub shaft. These bushings act as a spacer between the pulley and rotor bearing. Note the longer hub on one side of pulley. It is important that the longer hub be placed toward the inside of the machine to obtain the correct pulley alignment. Place the 1-7/16 bore pulley onto the stub shaft using the 1/4" square x 1-1/2" long key provided. Now place the 1/2" lockwasher and the 1-3/4" O.D. x 3/8" thick washer over the 1/2" (national fine thread) x 1-3/4" long capscrew. Wrench this capscrew firmly into the mating hole of the rotor shaft, thereby anchoring the pulley and machinery bushings firmly against the rotor bearing. See figure 2.

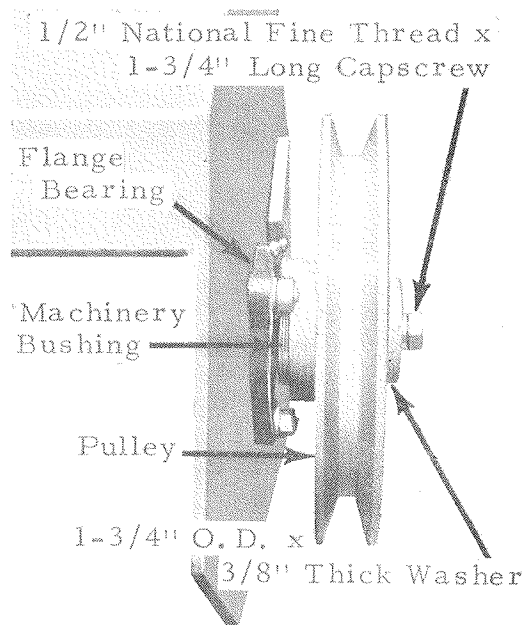

Figure 2

After fastening the pulley, install the self-locking collar to the right hand rotor bearing. Observe the cam design on the self-locking collar. Mate the cam of the collar with the cam of the bearing inner ring. Press the collar against the inner ring and turn the top side toward the front of the machine until tightly engaged. Using a drift pin inserted in the drift pin hole, lock the collar in place and tighten the set screw.

Study figure 3 carefully before assembling the bracket assembly on the outer side of the left hand end plate as shown. Use a 3/8" x 7/8" long capscrew, lockwasher, and nut in the rear hole. In the front hole, use the 3/8" x 1-3/4" long capscrew, one 3/8" standard nut, and one 3/8" locknut. Turn the standard nut onto the full thread length of the 3/8" x 1-3/4" capscrew. Align the front holes and insert the capscrew, with the head and nut to the inside. Fasten the 3/8" locknut on the outside leaving several threads exposed on the capscrew. Now tighten the inside nut, securing the bracket assembly to the end plate.

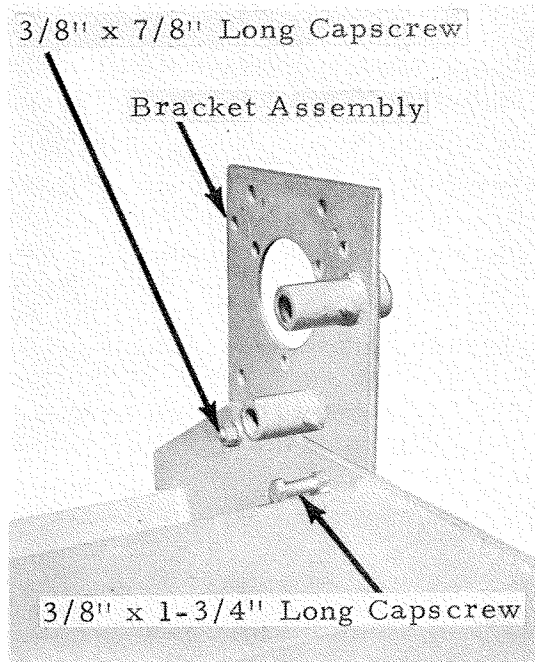

Figure 3

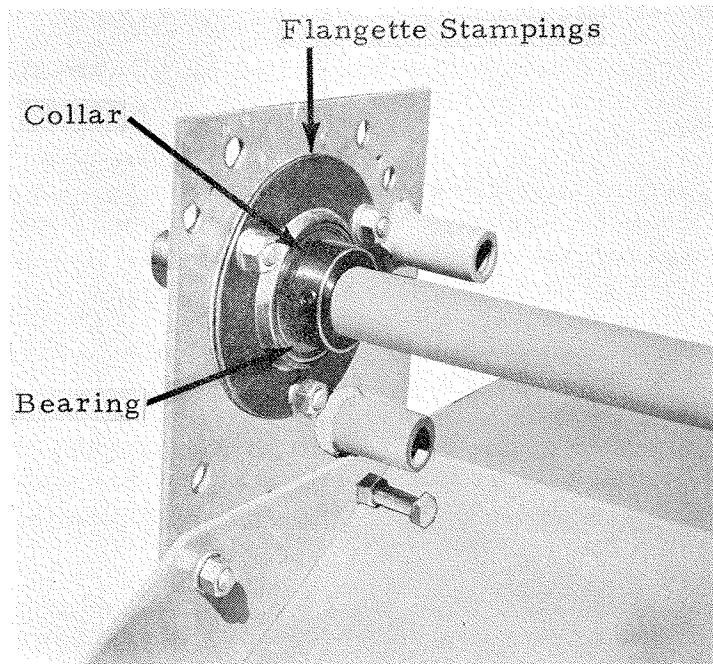

Figure 4

Proceed by inserting the 1/8" dia. x 1-1/2" long roll pin into the hole of the 1-1/2" O. D. x 3" long splined sleeve. Then place the splined sleeve over the mating spline of the gearbox output shaft. Before aligning the cross shaft with the splined sleeve, assemble the two flangette stampings, bearing, and collar onto the keyway end of the shaft. The stampings, bearing, and collar are to be placed on the inside of the bracket assembly. See figure 4. Position the bearing, with the inner ring cam design, to the inside, adjacent to the self-locking collar. Place the stamping with the lube fitting down and to the inside. To obtain the correct alignment between the gearbox and the cross shaft bracket assembly, it may be necessary to shim the gearbox in or out. Provided in the shipping specifications are eight 9D-74 steel shims (1-1/2" square x .007" thick) for this purpose. Before fastening the bearing and flangette stampings, check and measure the position of the cross shaft in relation to the hole opening in the bracket assembly. Push the cross shaft toward the gearbox until the splined sleeve is fully engaged with the mating splines. If the cross shaft is not exactly in the center of the hole, shim the necessary left or right vertical pairs of feet on the gearbox. The gearbox does not have to be removed from the hood mounting assembly to shim. Remove the two bolts on the side to be shimmed and loosen the two bolts on the other side enough to allow for inserting the shims. Use only the necessary number of shims to correctly align the cross shaft in the center of the bearing hole in the bracket assembly. Then proceed to assemble the unit. See figure 5. Attach the self-locking collar, the same way as described for the rotor bearing and collar.

The next step is to mount the idler arm rod into the upper tube of the bracket assembly. Note that there is a 3/16" dia. hole in the idler rod and also in the spring strap. Fit the spring strap onto the rod portion of the idler arm extending through the bracket tube. Pivot the spring strap around the rod until the 3/16" dia. holes are in alignment. Now insert the 3/16" dia. x 1-1/8" long roll pin to hold the spring strap in position, at an angle approximately 45 degrees above the idler arm. See figure 6.

Bolt the 3/8" x 1-3/4" long capscrew onto the spring strap in the position shown in figure 6. Use the 3/8" standard nut and the 3/8" locknut to secure the capscrew to the spring strap.

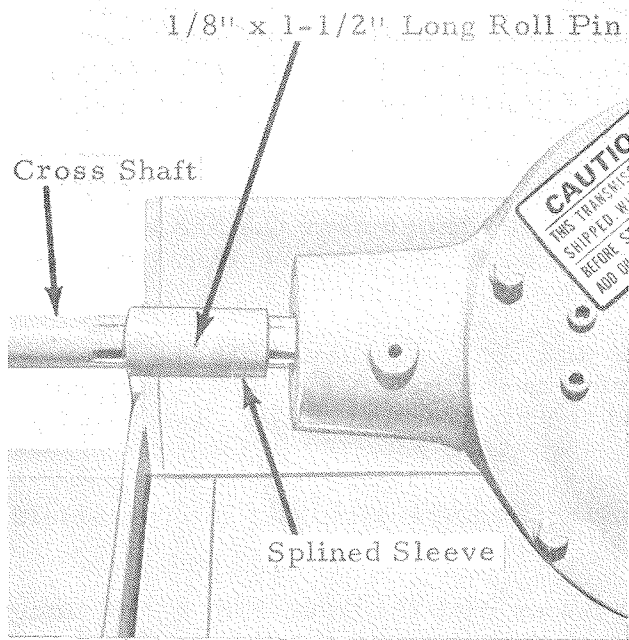

Figure 5

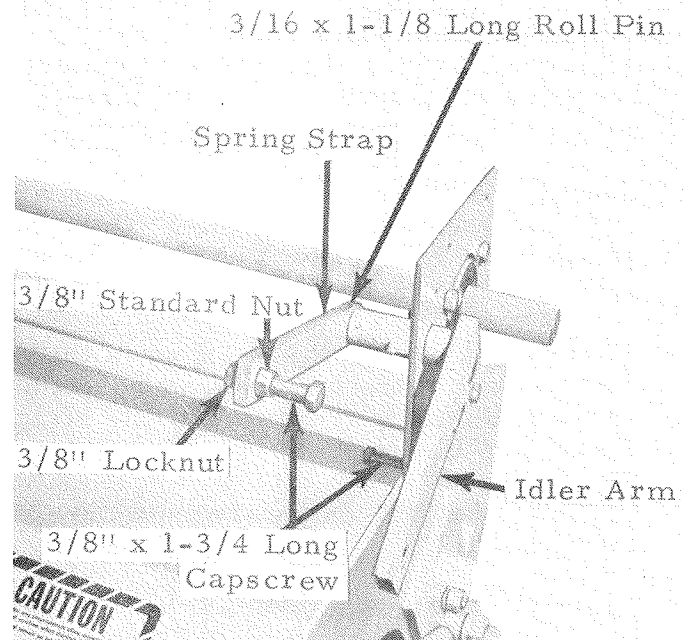

Figure 6

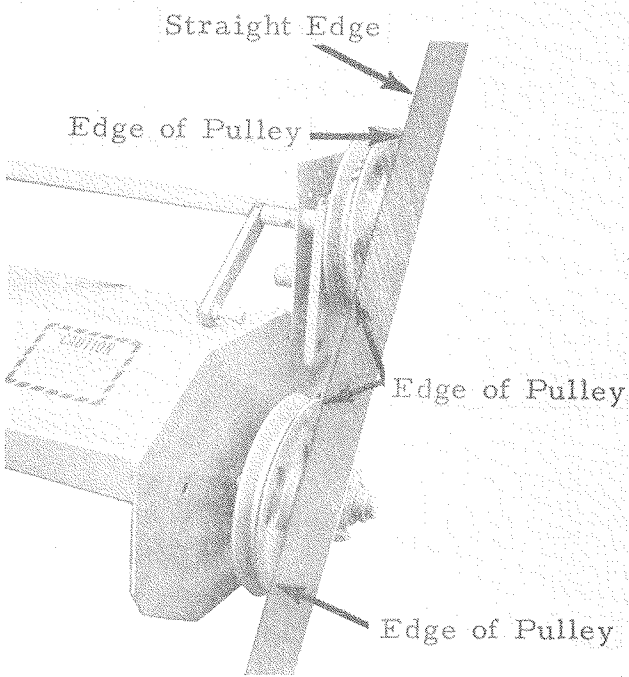

Figure 7

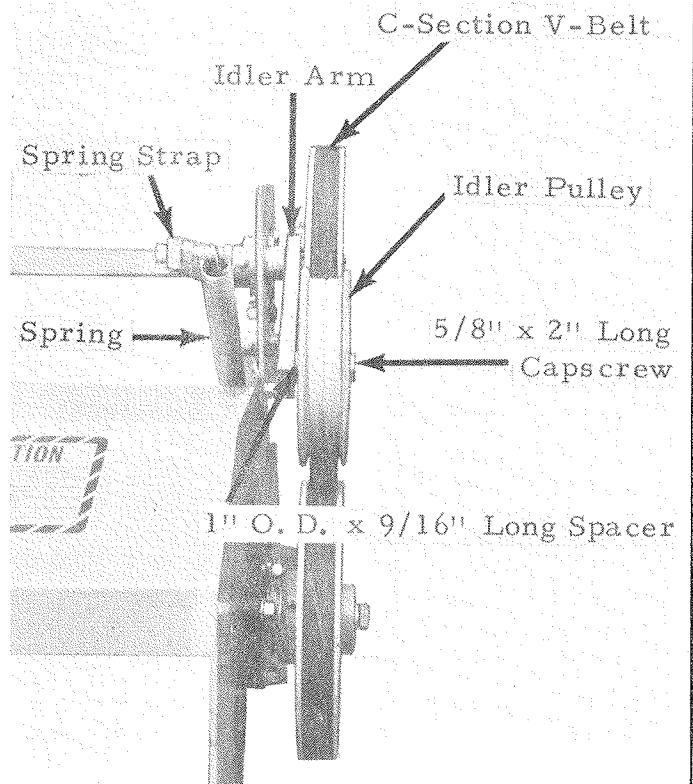

Figure 8

Assemble the 1-1/8" bore pulley to the cross shaft with the 1/4" square x 1-1/2" long key and the two 3/8" x 1" long set screws provided. Again it is important that the longer pulley hub be positioned toward the inside of the machine. To obtain alignment, lay a straight edge against the drive and driven pulleys. Straight edge should touch both edges of each pulley. Move the top pulley in or out to get the correct alignment. Then tighten the two set screws to secure the key and pulley onto the cross shaft. See figure 7.

Fasten the idler pulley to the idler arm with the 5/8" x 2" long capscrew and 5/8" lockwasher. Place the 1" O. D. x 9/16" long spacer over the 5/8 capscrew between the idler arm and the idler pulley. If assembled correctly, the three pulleys will now be in alignment. See figure 8.

Install the C-section V-belt over the drive and driven pulleys with the idler on the top side of the belt. Next hook the spring to the two 3/8 x 1-3/4 long capscrews extending from the spring strap and the bracket assembly. Refer to figures 6 and 8.

Be sure that all hardware is securely fastened before attaching the top shield and end shield.

Position the end shield over the pulleys and fasten with the three 3/8" x 7/8" long capscrews, lockwashers, and nuts. Insert hardware with the lockwashers and nuts to the outside. The longer clip on the end shield bolts to the top rear hole on the inside surface of the bracket assembly. See figure 9. The two short clips on the end shield bolt to the two holes in the end plate. The access hole in the end shield is designed for lubricating the rotor bearing without removing the shield.

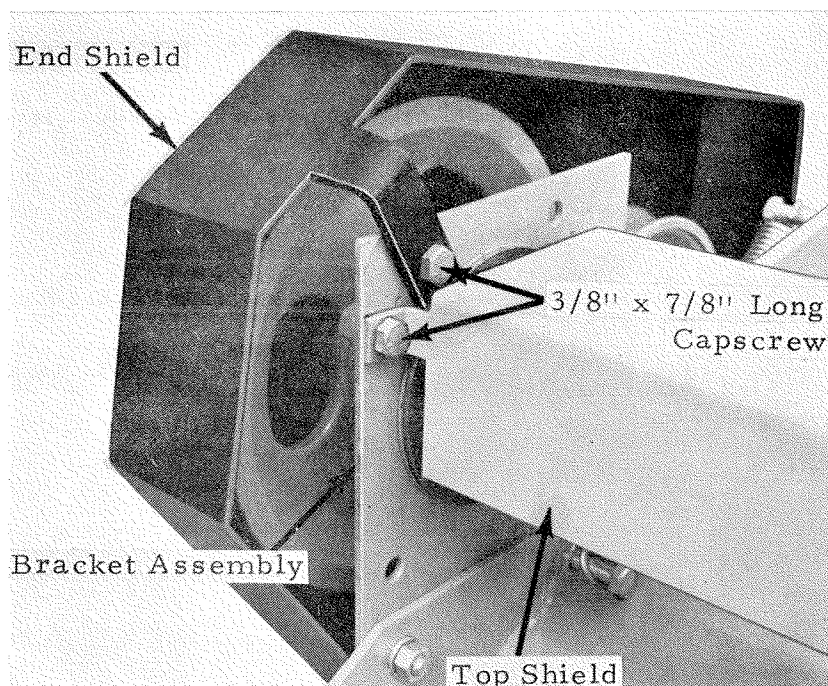

Figure 9



Place the top shield on top of the cross shaft with the two formed clips toward the bracket assembly. Use the two 5/16" x 1/2" long capscrews and lockwashers to bolt the shield to the tapped holes in the neck of the gearbox output shaft. Align holes in the formed clips, on the shield, with the second set of holes from the top on the bracket assembly. Fasten with the two 3/8" x 7/8" long capscrews, lockwashers, and nuts, with the nuts and lockwashers to the outside. See figure 9.

Next, place the 5/16" square x 2" long key into the keyway in the gearbox input shaft. Align keyway in P.T.O. shaft yoke with key and slide into position. Secure the yoke to the shaft with the 5/16" x 3" long capscrew and locknut. Lock the key into place using the 5/16" x 3/4" long socket head setscrew, securing the setscrew with the 5/16" jam nut. See figure 11.

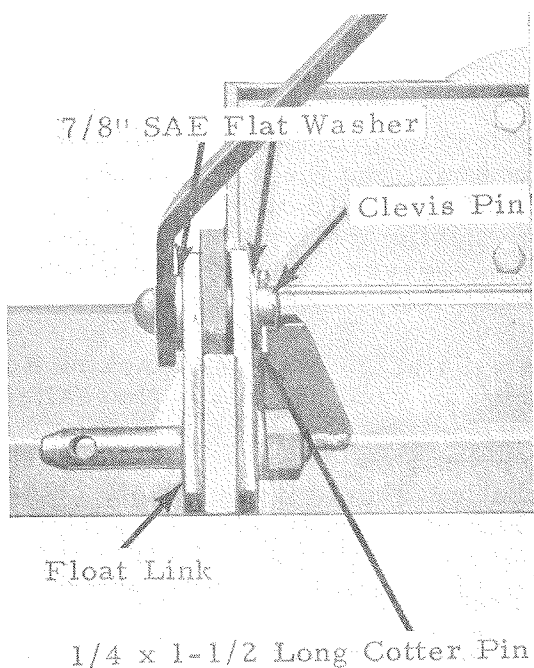

Figure 10

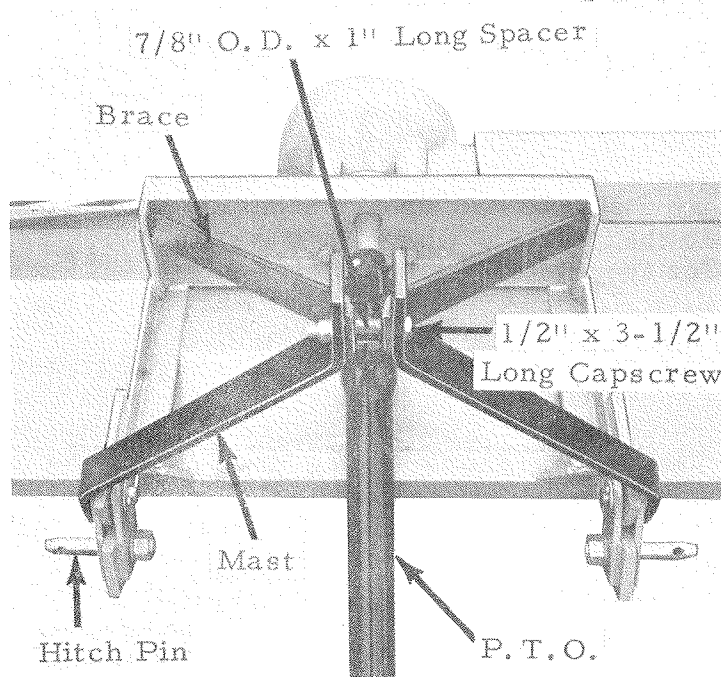

Figure 11

Study figures 10 and 11 carefully before mounting the mast, braces, and float links. Begin by attaching the left hand float link and mast to the hood hitch lug. Note that the hitch pins on the float links are to be toward the outside of the machine. Insert the 7/8" dia. x 2-1/2" long clevis pin into the 7/8" dia. hole of the mast. Now place a 7/8" S.A.E. flat washer over the clevis pin. Position the float link onto the hitch lug and insert the clevis pin along with the mast and flat washer. Place the second flat washer over the pin and fasten with the 1/4" dia. x 1-1/2" long cotter pin. Note the position of the clevis pin, the flat washer and cotter pin toward the inside of the machine. The flat washer between the mast and float link allows the float link to pivot up and down freely.

Assemble the right hand float link and mast in the same manner.

Proceed by bolting the braces to the gearbox mounting plate and to the top end of the mast. Observe that the brace has a short and a long bend. Fasten the end with the shorter bend to the inside surface of the gearbox mounting plate with the 1/2" x 1-1/2" long capscrew, lockwasher and nut. Place the lockwasher and nut on the inside and do not tighten until the other end of the brace is attached to the mast. Align the holes in the braces with the 1/2" dia. holes in the mast uprights. The 7/8" O.D. x 1" long spacer fits over the capscrew between the braces. The mast uprights bolt on the outside of the braces with the 1/2" x 3-1/2" long capscrew, lockwasher, and nut. See figure 11.

Your Brillion Mow-Safe mower is now completely assembled.

CAUTION: THIS MACHINE IS SHIPPED WITHOUT OIL IN THE GEARBOX. REMOVE UPPER 1/2" PIPE PLUG ON GEARBOX COVER TO ADD OIL. FILL TO LOWER 1/4" PIPE PLUG ON COVER WITH S.A.E. E.P. (EXTREME PRESSURE) NO. 90 OIL.

### MAINTENANCE

This shredder is designed to require simple lubrication procedures. The roller, rotor and cross shaft bearings, the idler pivot arm, and the P.T.O. shaft are relubricatable. Grease after every 8 hours of operation. The only oil check is in the gearbox, where the level is indicated by removing the lower 1/4" pipe plug for inspection. Check oil monthly. If adding is necessary, use a good grade of S.A.E. E.P. (EXTREME PRESSURE) No. 90 oil.

Before attempting to operate your Brillion Mow-Safe, go over the machine and check all bolts for tightness. Normal periodic checks should be made thereafter.

The knives should swing freely. If the knives become damaged or lost, the mower will begin to vibrate. The cause of vibration should immediately be determined and checked. Continued operation while unbalanced will cause severe damage to the machine. When necessary, replace these parts only with genuine Brillion parts. They are specially heat treated and sized to function properly.

It is important to maintain pulley alignment for normal belt life.

Lay a straight edge against the driver and driven pulleys. Straight edge should touch on both edges of each pulley. Adjust the drive pulley to get alignment. The idler should be centered on the belt.

### OPERATION

This machine is rated for general service in mowing grass, shredding weeds and mulching leaves.

When operating, set the cutting height so as to avoid rocks, wire, etc. For maximum safety and efficiency, keep blades out of the ground. Short life of the blade edge almost always means abrasive or rocky conditions have been encountered.

If it is necessary to change cutting height, adjust rear roller and the upper link of the tractor accordingly to keep the machine level.

When level, the input shaft on the gearbox is parallel to the tractor P. T. O. shaft while the rear roller is on the ground.

It is recommended that the roller be set in the lower cutting positions when cutting lawns and on level areas. When used in rough or trashy areas, the knives will last longer if the roller is adjusted to the higher positions. Remove the 1/2" x 1-1/4" capscrews to change position of roller gauge arm. There are two positions in the gauge arm and four positions in the side plate to provide a total of eight positions.

Always start the mower where the rotor is free to get up to full operating speed before cutting is required. Maintain 540 RPM P. T. O. speed while mowing to attain best results.

Never run the machine without a full set of knives. If one knife assembly is replaced with a new one, the closest set, 180° opposite, must also be replaced with a new assembly. This is necessary to maintain proper rotor balance which prevents machine vibration.

#### STORAGE

Before placing your Mow-Safe in storage, release the idler tension from the V-belt. This will reduce unnecessary strain and stretch on the belt.

Grease the P. T. O. shaft and bearings when machine is not being used for a long period of time. This will keep moving parts from "freezing tight" due to moisture and corrosion.

Also remove old grass and debris that may have collected during the mowing season.

If desired, the rotor and knife assembly can be coated with light oil to minimize corrosion.

