

REPAIR PARTS CATALOG

FOR

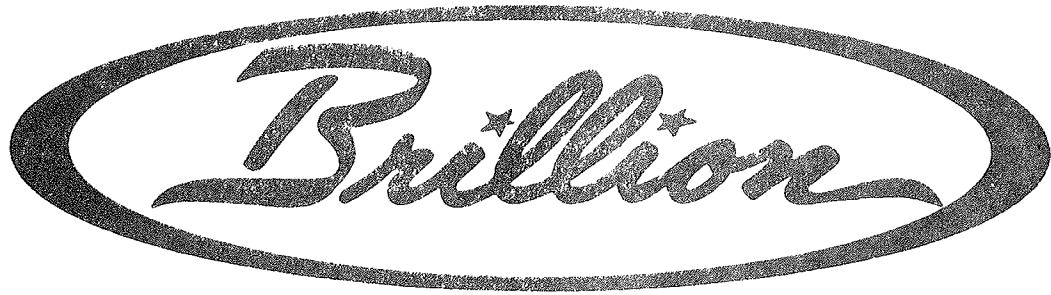

MOW SAFE MOWER

MODEL MSC 720-02

AND

MODEL MSO 720-02

MODEL NO.
DATE PURCHASED

A product of the

BRILLION IRON WORKS • BRILLION, WISCONSIN

ALL PARTS NOT LISTED ARE STANDARD HARDWARE

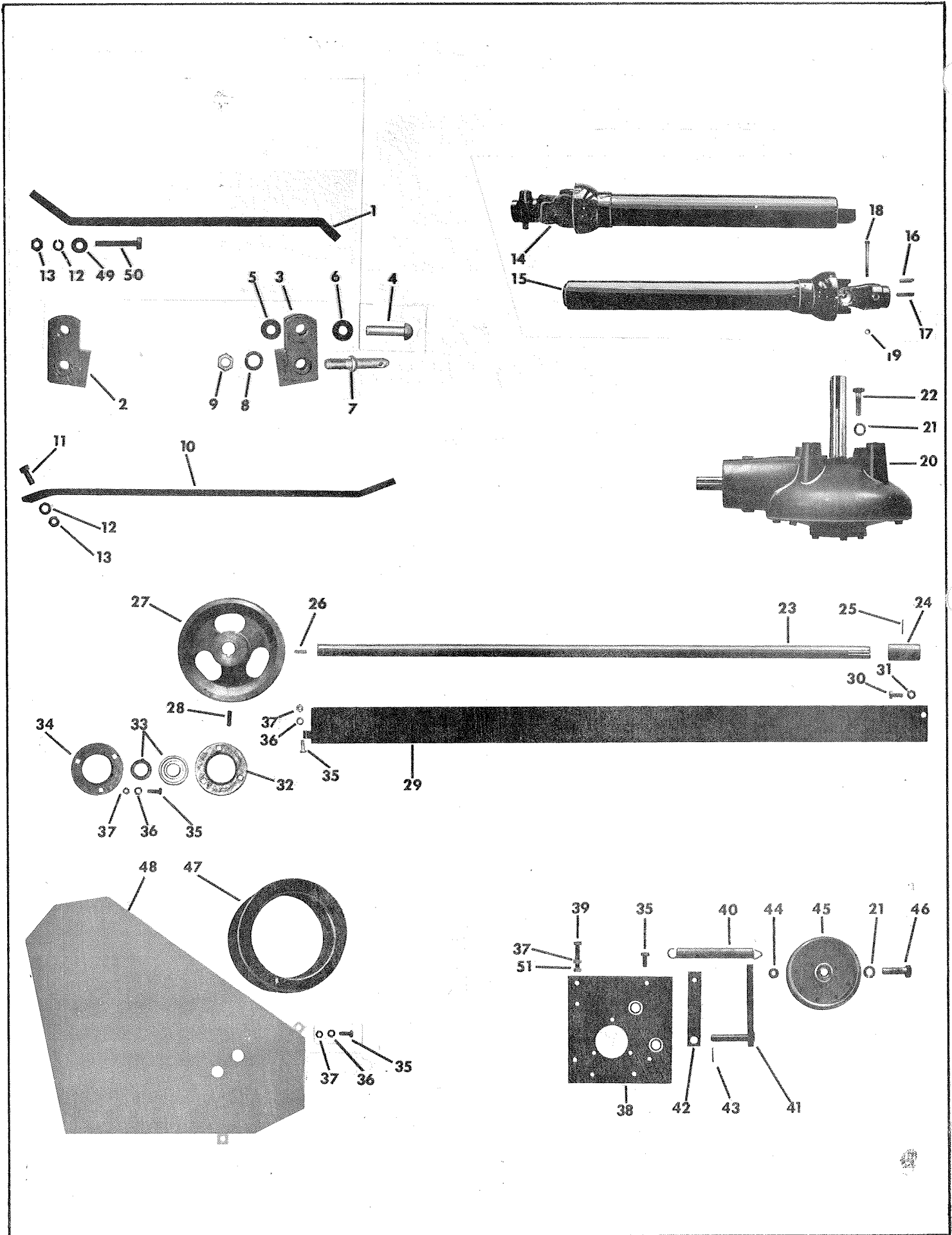

Index No.	Part No.	Description	No. Req'd.	Weight
*	8D-681	Hood Weldment	1	150.0
*	8D-698	Hood Weldment (with caster wheel plates)	1	165.0
*	8D-682	Gearbox Mounting Assembly	1	33.0
*		Nut, 5/8-11 NC Reg. Hex	2	.05
1	8D-717	Mast	2	7.0
2	7D-110	Right Hand Float Link	1	4.0
3	7D-109	Left Hand Float Link	1	4.0
4	7D-815	Clevis Pin, 7/8 Dia. x 2-1/2 Long	2	.6
5		Washer, 7/8 S.A.E. Flat	2	.08
*	5D-110	Kiik Pin	2	
6	7C-120	1" Machinery Bushing	2	
7	5D-186	Hitch Pin (Category I)	2	1.0
8		Lock Washer, 7/8 Spring Lock	2	.12
9	1D-218	Nut, 7/8-14 N.F., Reg. Hex	2	.25
10	7D-829	Brace	2	3.8
11	8C-527	Capscrew, 1/2-13 NC x 1-1/2 Long, Grade 5	6	.12
12		Lock Washer, 1/2 Medium	7	
13		Nut, 1/2-13 NC, Reg. Hex	7	
14	7D-810	Shaft & Joint Assembly	1	16.5
*	7D-157	End Yoke W/Spring & Lock Pin	1	3.0
*	7C-265	End Yoke	1	2.73
*	5C-257	Lock Pin Spring	1	.03
*	3D-757	Lock Pin	1	.25
*	7C-270	Universal Joint Repair Kit	2	1.0
*	7D-813	Yoke & Shaft	1	9.50
*	1D-131	Bearing Retainer	2	.01
*	2D-140	Nylon Bearing	2	.02
*	7D-814	Guard Tube	1	3.1
15	7D-809	Joint & Tube Assembly	1	13.0
*	7D-54	Yoke	1	2.0
*	7D-811	Yoke & Tube	1	6.3
*	7D-812	Guard Tube	1	4.0
*	1D-854	Nylon Centralizer	1	.03
16	7C-614	Set Screw, 5/16-18 NC x 3/4 Long	1	
*	6C-223	Jam Nut, 5/16-18 NC	1	
17	7D-176	Key, 5/16 Sq. x 2" Long	1	
18	1D-239	Capscrew, 5/16-18 NC x 3 Long, Grade 5	1	
19	6C-748	Lock Nut, 5/16-18 NC Hex	1	
20	7D-149	Drive Assembly - Complete	1	74.2
21		Lock Washer, 5/8 Medium	7	
22	4D-561	Capscrew, 5/8-11 NC x 1-1/2 Long, Grade 5	6	
23	8D-679	Cross Shaft, 16-15/16" Long	1	4.8
*	7D-848	Cross Shaft, 28-7/16" Long	1	8.0
24	1 J-719	Sleeve Assem. (Includes 7D-248 Pin)	1	.75
25	7D-248	Roll Pin, 1/8 Dia. x 1-1/2 Long	1	
26	8C-218	Key (Cross Shaft) 1/4" Sq. x 1-1/2 Long	1	.03
27	7D-82	Pulley (1-1/8 I.D.)	1	9.0
28	2C-975	Set Screw, 3/8-16 NC x 1" Long, Cup Point	2	.04
29	8D-680	Top Shield, 18" Long	1	3.5
*	7D-803	Top Shield, 29-1/2" Long	1	5.5
30		Capscrew, 5/16-18 NC x 1-1/2 Long	2	.02
31		Lock Washer, 5/16 Medium	2	
32	7D-162	Flangette Stamping	1	.40
33	7D-163	Bearing & Collar (1-1/8")	1	.75
34	7D-161	Flangette Stamping W/Lube Fitting	1	.42
35	7D-792	Capscrew, 3/8-16 NC x 7/8 Long, Grade 5	9	.02
36		Lock Washer, 3/8 Medium	9	
37		Nut, 3/8-16 NC, Reg. Hex	11	.01
38	7D-842	Bracket Assembly	1	3.2
39	8C-36	Capscrew, 3/8-16 NC x 1-3/4 Long, Grade 5	2	.08
40	7D-62	Spring	1	.50
41	7D-845	Idler Arm	1	1.5
42	7D-847	Spring Strap	1	.65
43	7C-870	Roll Pin, 3/16 Dia. x 1-1/8 Long	1	
44	7D-133	Spacer	1	.20
45	7D-58	Idler Pulley	1	1.50
46	5C-460	Capscrew, 5/8-11 NC x 2 Long, Grade 5	1	.04
47	7D-802	V-Belt, C-Section	1	1.0
48	7D-804	End Shield	1	15.0
49	5D-312	Spacer	1	.20
50	5D-871	Capscrew, 1/2-13 NC x 3-1/2 Long, Grade 5	1	.40
51	5C-954	Lock Nut, 3/8-16 NC, Reg. Hex	2	.01

*Parts Not Shown

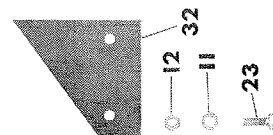
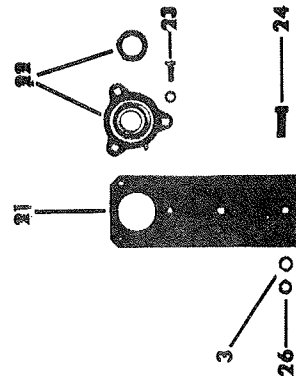
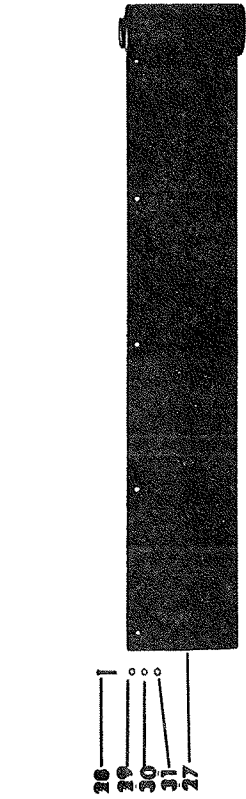
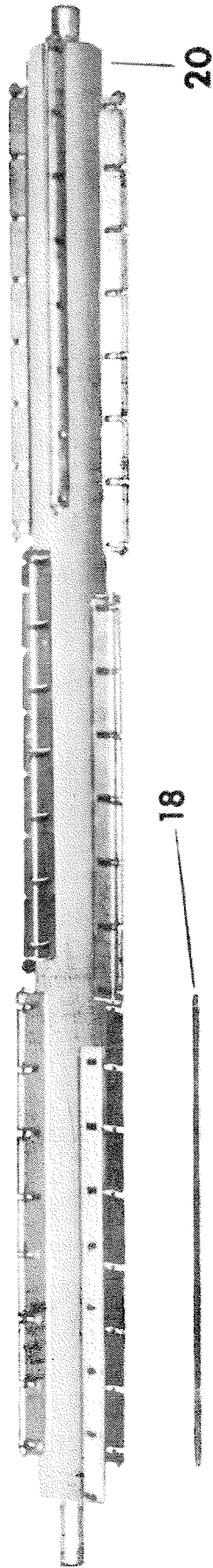
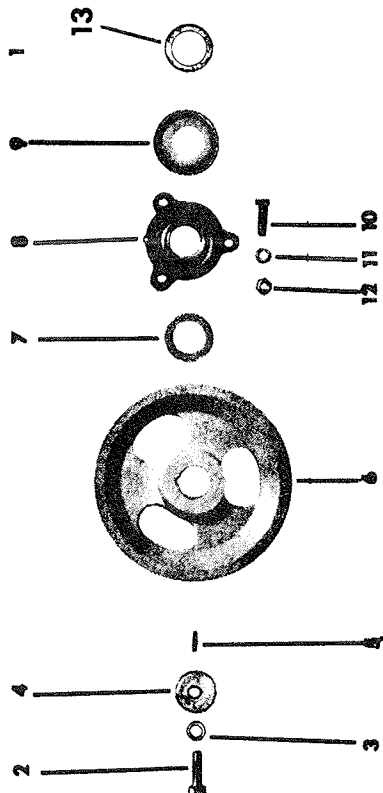
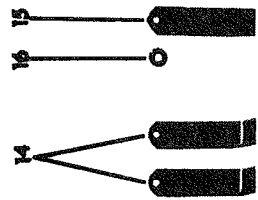
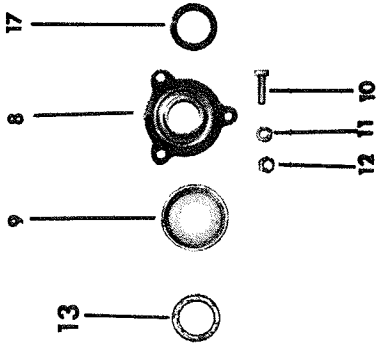
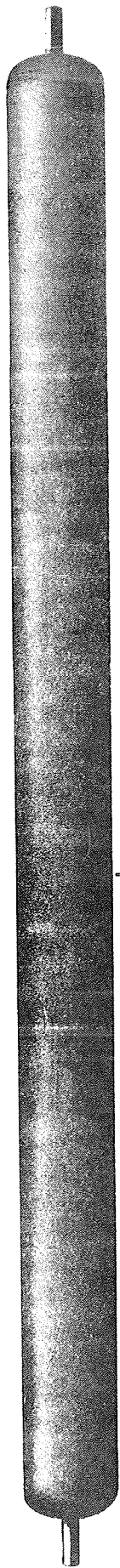

MOW-SAFE MOWER

MODELS: MSO-720-02
MSC-720-02

Index No.	Part No.	Description	No. Req'd.	Weight
1	7D-849	Roller Assembly	1	78.0
2		Capscrew, 1/2 N.F. x 1-3/4 Long	1	.02
3		Lockwasher, 1/2 Medium	3	
4	7D-827	Washer	1	.4
5	8C-218	Key (Rotor Shaft) 1/4 Square x 1-1/2 Long	1	.03
6	7D-824	Pulley (1-7/16 I.D.)	1	9.0
7	6D-966	Machinery Bushing (2-1/4 O.D. x 1-1/2 I.D. x .075 Thick)	3	.05
8	7D-817	Flange Bearing (1-7/16 Dia.)	2	2.0
9	7D-885	Bearing Slinger	2	.5
10	9C-78	Capscrew, 3/8-16 NC x 1-1/4 Long, Grade 5	6	.05
11		Lockwasher, 3/8" Medium	8	
12		Nut, 3/8-16 NC, Regular Hex	8	.02
13	8D-88	Spacer, 1-29/32" O.D. x 1-1/2" I.D. x 1/4" Thick	2	.1
14	8D-90	Knife - Standard	184	.14
15	8D-100	Knife - Thatching (optional)	92	.13
16		Washer, 5/16 Std. Flat	92	.01
17	6C-793	Bearing Collar (1-7/16)	1	.30
18	8D-96	Hanger Rod, 20-3/16" Long) Obsolete - order	4	.50
	8D-97	Hanger Rod, 23-5/16" Long) 9D-406, 9D-407, 9D-408	8	.50
	9D-406	Hanger Rod, 24-11/16" Long	6	.50
	9D-407	Hanger Rod, 21-9/16" Long	4	.50
	9D-408	Hanger Rod, 24-1/16" Long	2	.50
19		Cotter Pin, 1/8" Dia. x 1" Long	24	
20	8D-95	Rotor Assembly Obsolete - order 9D-409	1	85.0
	9D-409	Rotor Assembly	1	85.0
	7D-850	Rotor & Knife Assembly (Complete with rods, cotter pins, & 8D-90 knives)	1	120.0
21	7D-105	Roller Gauge Arm	2	3.9
22	7D-57	Bearing & Collar - 1-1/8"	2	1.50
23	7D-792	Capscrew, 3/8-16 NC x 7/8" Long, Grade 5	8	.04
		Lockwasher, 3/8 Internal Lock	6	
24	6C-347	Carriage Bolt, 1/2-13 NC x 1-1/4" Long	2	.06
26		Nut, 1/2-13 NC, Regular Hex	2	.02
27	7D-887	Shield Strip	1	2.0
28		Machine Screw, 1/4-20 NC x 5/8 Long	10	.02
29		Flat Washer, 1/4 Standard	10	
30		Lockwasher, 1/4 Medium	10	
31		Nut, 1/4-20 NC, Regular Hex	10	
32	8D-98	Cover Plate	1	1.9

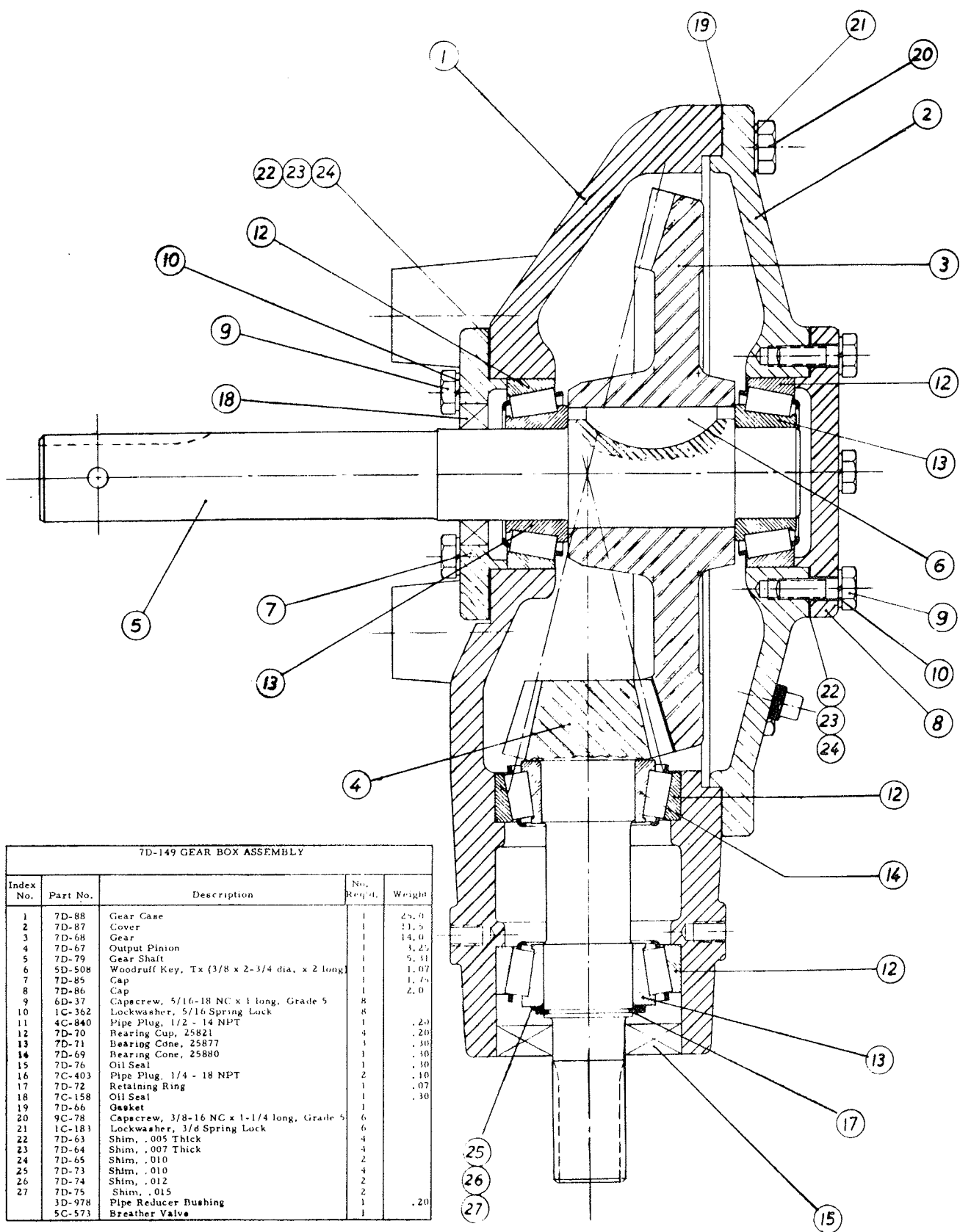

7D-149 GEAR BOX ASSEMBLY				
Index No.	Part No.	Description	No. Req'd.	Weight
1	7D-88	Gear Case	1	25.8
2	7D-87	Cover	1	11.5
3	7D-68	Gear	1	14.0
4	7D-67	Output Pinion	1	3.25
5	7D-79	Gear Shaft	1	5.31
6	5D-508	Woodruff Key, Tx (3/8 x 2-3/4 dia. x 2 long)	1	1.07
7	7D-85	Cap	1	1.75
8	7D-86	Cap	1	2.0
9	6D-37	Capcrew, 5/16-18 NC x 1 long, Grade 5	8	
10	1C-362	Lockwasher, 5/16 Spring Lock	8	
11	4C-840	Pipe Plug, 1/2 - 14 NPT	1	.20
12	7D-70	Bearing Cup, 25821	4	.20
13	7D-71	Bearing Cone, 25877	1	.30
14	7D-69	Bearing Cone, 25880	1	.30
15	7D-76	Oil Seal	1	.30
16	7C-403	Pipe Plug, 1/4 - 18 NPT	2	.10
17	7D-72	Retaining Ring	1	.07
18	7C-158	Oil Seal	1	.30
19	7D-66	Gasket	1	
20	9C-78	Capcrew, 3/8-16 NC x 1-1/4 long, Grade 5	6	
21	1C-181	Lockwasher, 3/4 Spring Lock	6	
22	7D-63	Shim, .005 Thick	4	
23	7D-64	Shim, .007 Thick	4	
24	7D-65	Shim, .010	2	
25	7D-73	Shim, .010	4	
26	7D-74	Shim, .012	2	
27	7D-75	Shim, .015	2	
	3D-978	Pipe Reducer Bushing	1	.20
	5C-573	Breather Valve	1	

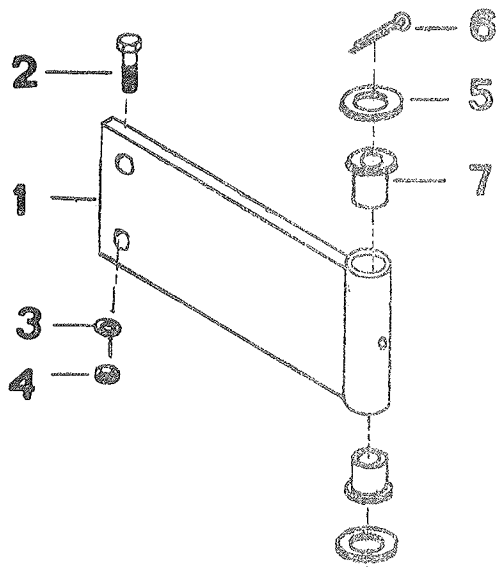

WHEEL & FORK ASSEMBLY				
Index No.	Part No.	Description	No. Req'd.	Weight
1	7D-876	Tube Weldment	1	7.0
2	1D-237	Capacrew, 1/2-13 NC x 2" Long, Grade 5	2	.1
3	1C-109	Lockwasher, 1/2" Regular	2	
4	1C-390	Nut, 1/2-13 NC Regular Hex	2	
5	1C-871	Washer, 1" S.A.E. Flat	3	
6	1C-869	Cotter Pin, 1/4 Dia. x 2" Long	1	
7	7D-305	Flange Bushing	2	.1
8	9C-223	Nut, 1"-14 N.F. Hex Stover	1	.2
9	7D-303	Fork Assembly	1	11.0
10	9C-222	Axle Assembly	1	2.3
<u>Wheel Components (Pneumatic)</u>				
11	5D-943	Axle Sleeve	2	.1
12	9C-228	Seal	2	.1
13	9C-227	Bearing Cone	2	.2
14	9C-226	Bearing Cup	2	.2
15	6D-68	Rim & Hub Assembly	1	14.0
	5D-945	Tire (13 x 6.50-6 tubeless)	1	4.5
	6D-70	Valve Stem	1	
<u>Wheel Components (Semi-Pneumatic)</u>				
16	1J-122	Wheel (complete assembly)	1	8.5
17	1J-123	Spacer	2	.1
18	7C-120	Machinery Bushing (18 Ga.)	4	

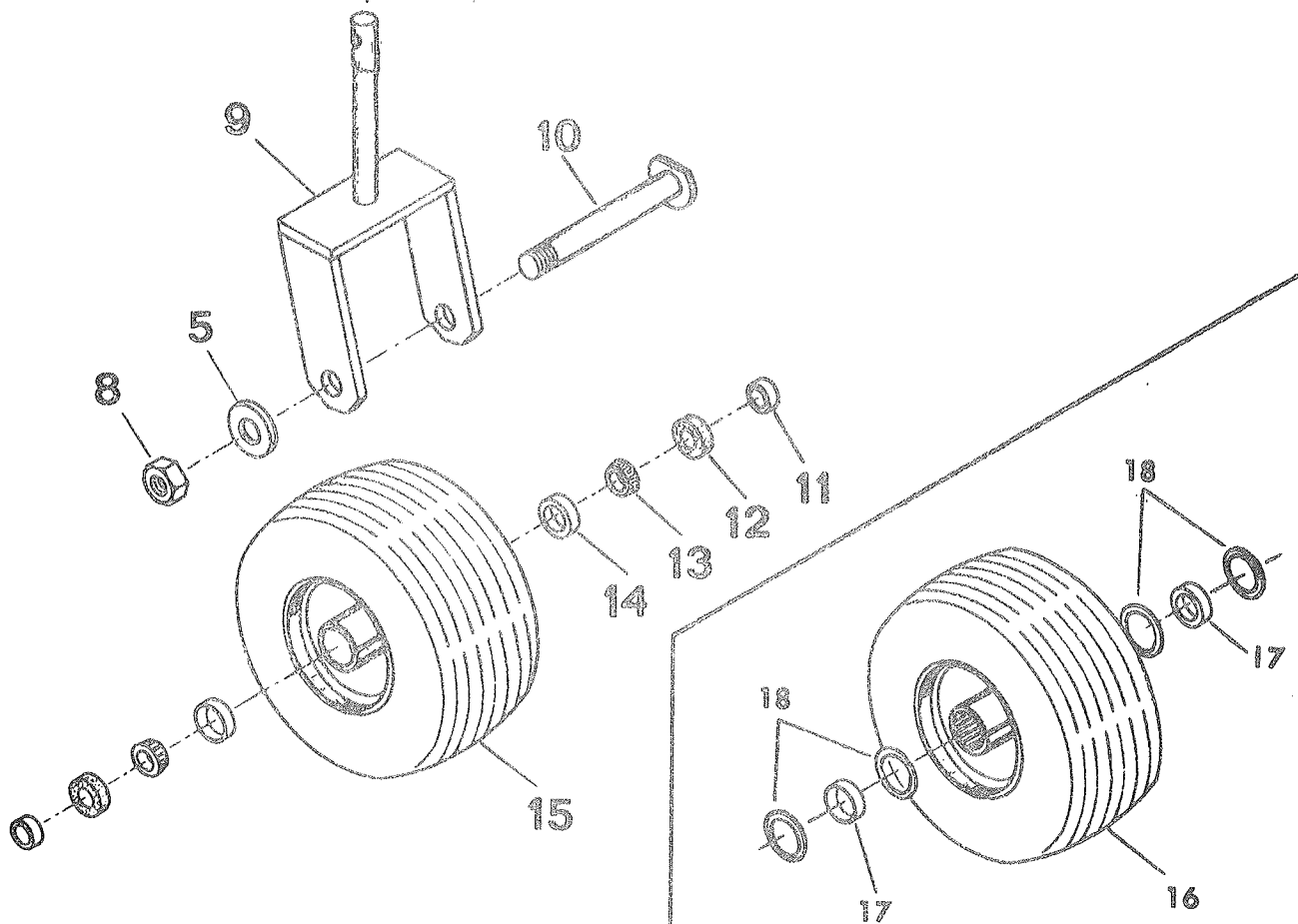

P. T. O. SHIELD

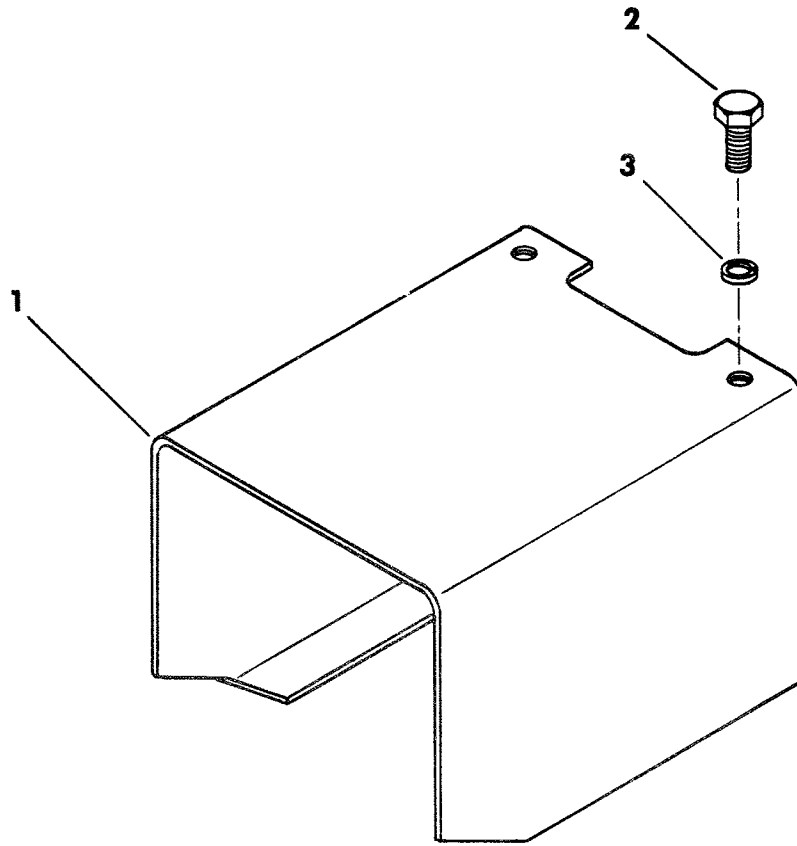

Index No.	Part No.	Description	No. Req'd.	Weight
1	2J-134	Shield	1	3.5
2	1C-237	Capscrew, 5/16" x 3/4" Long	2	
3	1C-362	Lockwasher	2	