

OPERATOR'S MANUAL

Brillion Foragemaster SILO UNLOADER

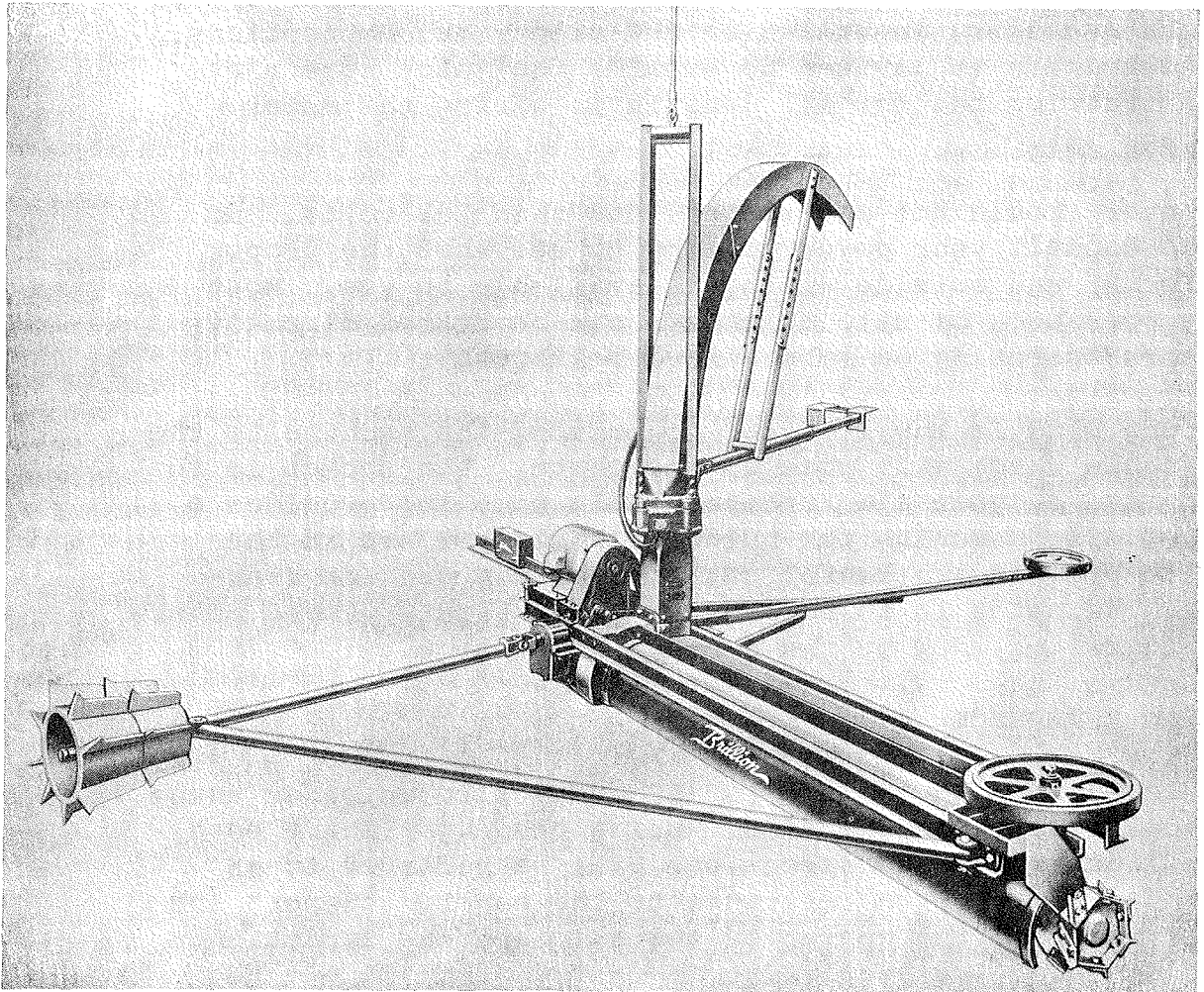

BRILLION IRON WORKS, INC.
BRILLION, WISCONSIN

INSTALLATION AND OPERATING INSTRUCTIONS

BRILLION FORAGE-MASTER SILO UNLOADER

General:

Your Brillion FORAGEMASTER Silo Unloader is built with the best materials and workmanship available.

Careful advance planning before installation and strict following of the operation and maintenance instructions included in this manual will assure you of trouble-free operation.

811-28

POWER REQUIREMENTS:

A 220 volt, single phase, repulsion-induction motor is furnished for your silo unloader, unless ordered otherwise. You are advised to consult a local electrician to make the necessary installation and electrical connections. The electrician is invited to examine the motor name plate and instruction tag for all details in wiring the motor (see page 35).

This motor should not operate at less than 208 volts. Be sure to consult your power company to see that the proper transformer and outside wiring is available to you. Most faulty operation of silo unloaders can be traced directly to motors operating on substandard voltages.

A 3-prong plug is supplied for connecting the machine to the power cable which will come up the chute. The socket is to be provided by your electrician. This coupling provides a means of disconnecting the unloader while you are in the silo, to prevent accidental starting of the machine from below. The motor is to be started ONLY by an approved motor-starting switch, NOT by the 3-prong disconnect.

LOCATION REFERENCE:

When viewed from above, the FORAGEMASTER silo unloader turns counter-clockwise in the silo. Using the auger shaft as a center line, parts and directions will be referred to as "front" or "rear" with reference to the auger. "Inner" and "outer" refer to the center of the silo and the direction toward the wall, respectively.

Study the general view of the machine on page 3. Notice the general arrangement of parts, the direction of travel and "front" and "rear", "inner" and "outer" sides of the machine. ~~Step-by-step~~ assembly instructions are on following pages.

8C-118

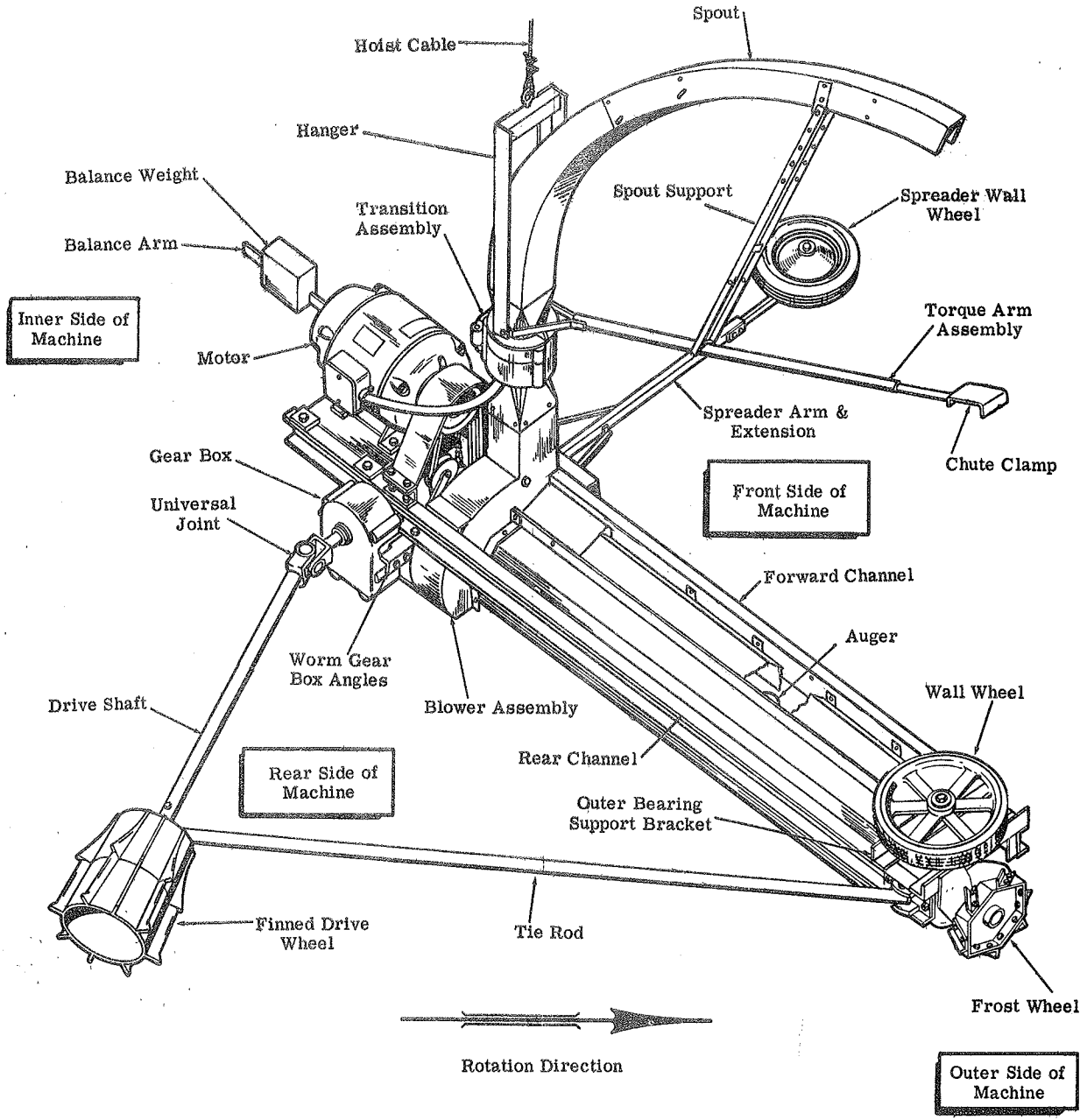

GENERAL COMPONENTS OF MACHINE

TRIPOD INSTALLATION:

Before moving the machine proper into the silo for assembly, study the installation of the tripod and the hoisting cable.

Examine the three tripod legs. You will note that one leg has, at its base, a bracket, wider than the others, with two holes pierced for mounting the top pulley bracket. This leg of the tripod, when installed on the top rim of the silo, should be placed at the point where you wish the cable to come through the silo dome. You will note that all three of the tripod legs take an "L" shaped safety hook, in a sleeve, which locks the tripod to the top of the silo rim, and which projects downward on the outside of the silo.

The tripod is usually taken into the silo unassembled, and assembled and placed in position inside. The bag of tripod parts is tagged 6C-759, 7C-450 or 7C-451 depending on size of unit. Assemble the three tripod legs to the tripod crown, which contains the top hoist pulley bracket, with the three 5/8" diameter pins and cotter pins. The crown is assembled to the tripod so that the pulley bracket, which will support the top hoist pulley, is toward the same leg as the top pulley bracket mentioned in the paragraph above. The crown is mounted so that this top hoist pulley hangs inside the tripod assembly. The tripod is placed into position with the legs spread equal distances apart around the silo circumference. In selecting the position for the tripod legs, place them on a full length stave, rather than on a half size stave, in stave type silos. The dome is pierced if necessary and the safety hooks installed and locked in place.

As a safety measure, to keep the tripod legs from pushing out the top staves of the silo, a short cable is strung between the three brackets on the inside of the tripod legs and tightened with a turnbuckle. Do not tighten this turnbuckle too tightly, as you may pull the legs off the silo rim.

With the tripod installed, the top pulley bracket may be mounted on the tripod leg located where the cable is to come down the silo. To install this pulley, it will be necessary to pierce the silo dome. The material cut from the dome may be bent upward to form a small shield over the pulley.

With the cable strung down to the bottom of the silo on the outside, the position for mounting the winch may be determined.

8C-118

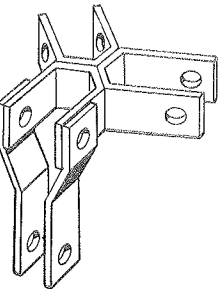
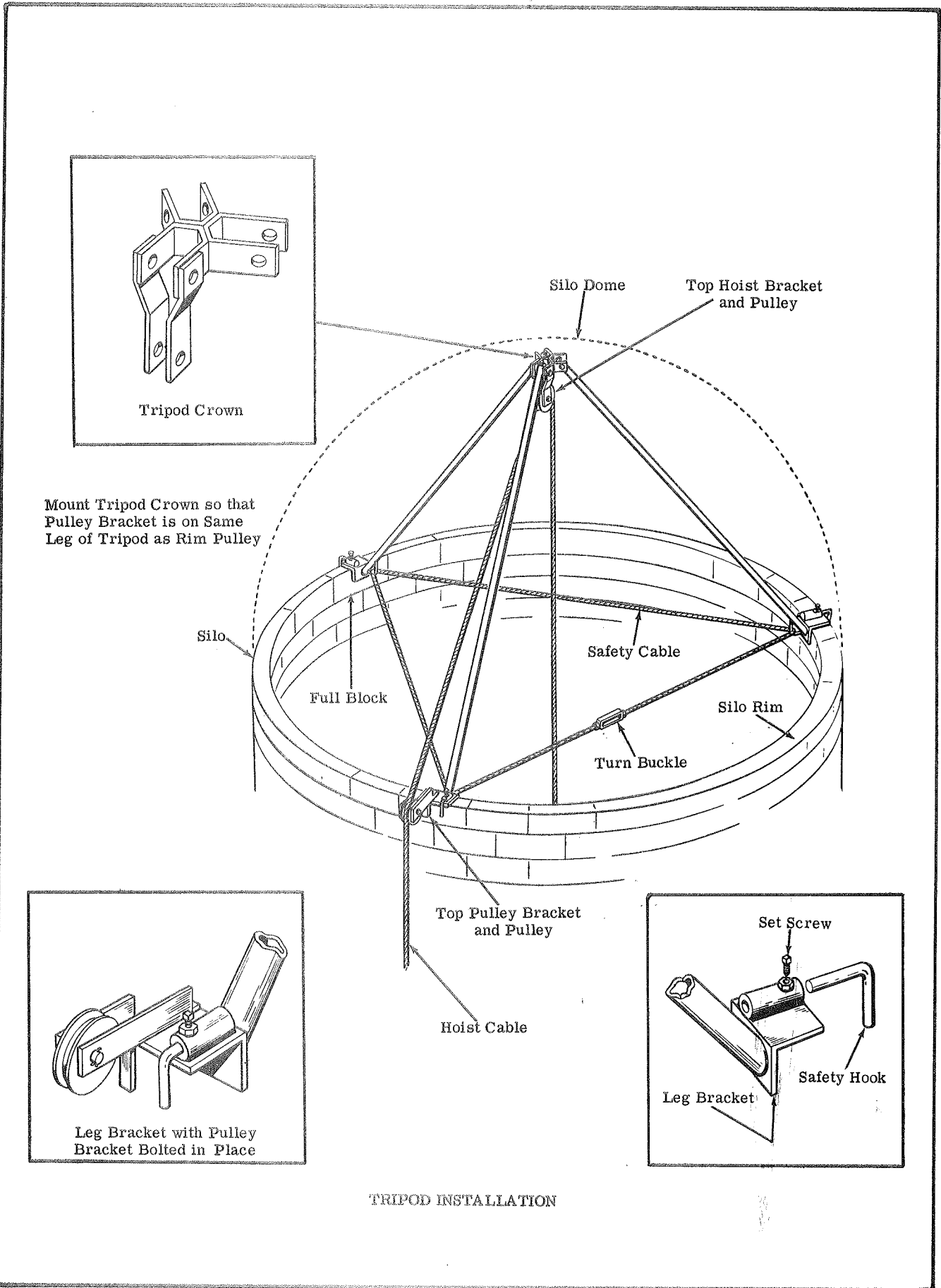

Tripod Crown

Mount Tripod Crown so that Pulley Bracket is on Same Leg of Tripod as Rim Pulley

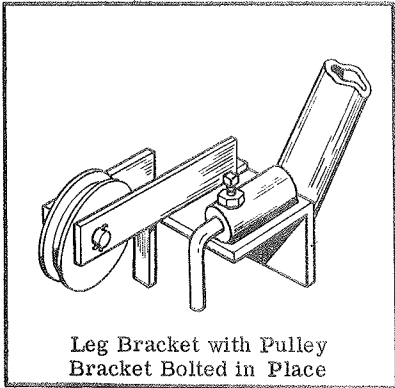

Leg Bracket with Pulley Bracket Bolted in Place

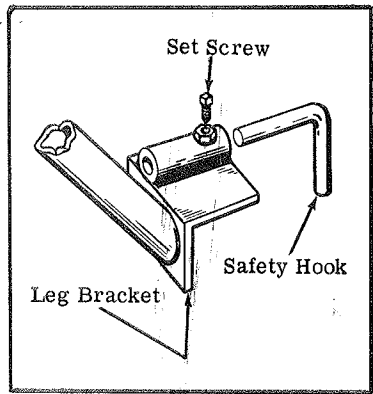

Leg Bracket

TRIPOD INSTALLATION

WINCH INSTALLATION:

The winch may be installed in a variety of ways. The simplest method is to bolt it directly to the silo wall. It may be mounted on the reinforcing bands using the "J" bolts as shown in the illustration or it may be installed with Ackerman bolts. In some cases, the winch is bolted to the side of the feed room or to the ceiling by using Ackerman bolts.

If the winch is to be mounted on the side of the silo, it is desirable to mount it directly under the top pulley so that the line of cable will come down the side of the silo to the winch. If such a mounting is undesirable, the bottom pulley and bracket assembly may be used to cause a single change of direction in the cable. This pulley may be supported on one of the reinforcing bands. Allow at least 3 feet from pulley to winch, so the cable will wind properly.

If the winch housing is bolted to a flat surface, the bolts may pass directly through the housing. If, however, it is to be mounted on a curved surface, the silo wall, for example, the winch mounting angles must be used to spread the load on the winch over a greater area. When installing the winch and various supporting pulleys, keep in mind that the load on the cable will often be in the neighborhood of 1,000 lbs. From a safety standpoint, it is advisable to have the installation too sturdy and too strong rather than too weak.

Place the end of the cable through the hole in the flange of the winch drum, and clamp it securely with the clamp bolt. ALWAYS KEEP AT LEAST FIVE TURNS OF CABLE ON THE DRUM.

The cable supplied with Brillion Forage-Master Silo Unloaders is 1/4" 7 x 19 Preformed Galvanized Aircraft Cable. It has a minimum breaking strength of 7000#, assuring you of a 7 to 1 safety factor.

IMPORTANT

NEVER PERMIT THE CABLE TO KINK

NEVER LET THE CABLE DRAG AGAINST OBSTRUCTIONS, WALLS, SIDE OF SILO, ETC.

INSPECT CABLE YEARLY, AND REPLACE WHEN FRAYED OR CORRODED, OR EVERY FIVE YEARS.

REPLACE ONLY WITH CABLE SUPPLIED BY BRILLION

8
-
8

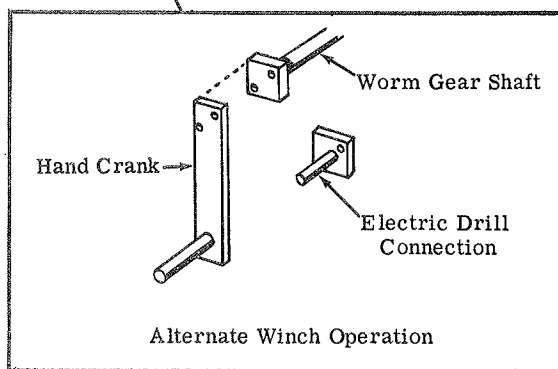
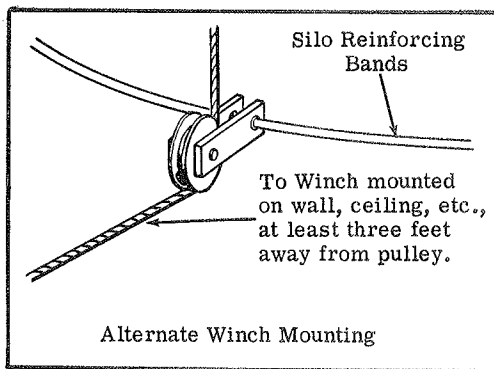
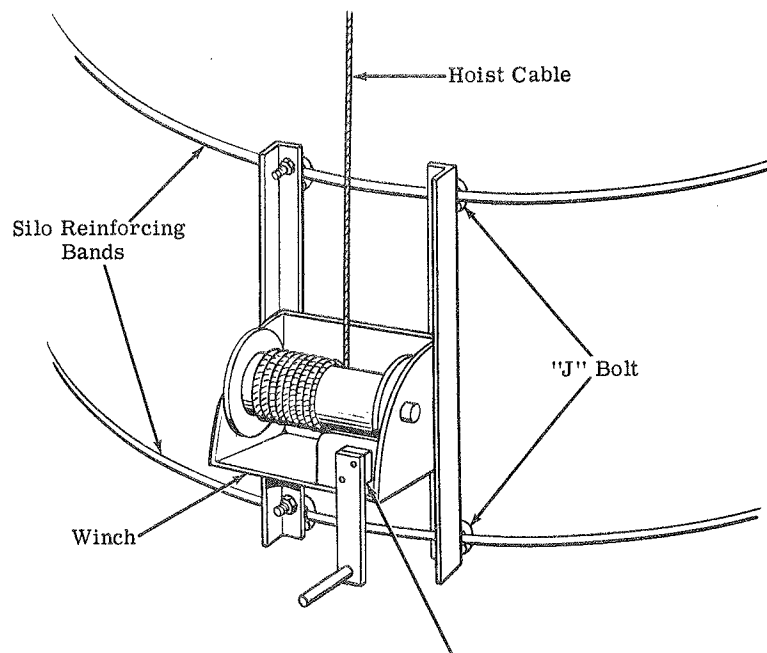

WINCH INSTALLATION

ASSEMBLY OF SILO UNLOADER PROPER:

This part of the operation is at least a two man job. Before moving the parts of the unloader into the silo, it may be advisable to level off the silage somewhat to give yourself a good place to work. A block and tackle should be installed and secured solidly at the top of the chute. This will be a great aid in hoisting heavy parts, particularly the electric motor, into position, without endangering anyone working below. Lay out on the top of the silage a small piece of canvas where small fasteners and parts may be placed so that they will not get lost.

Begin by bringing the parts up the chute in order of assembly, so that they may be put together in an orderly manner, and the area may be kept clear.

In bolting the machine components together, leave the bolts loosely assembled until the machine is completely together, unless otherwise instructed.

First bring into the silo the side channel bundle, the blower assembly, the auger, and bag assemblies tagged 8C-112 and 8C-546. Open the bag assemblies and lay the parts out on the canvas mentioned above. Necessary nuts, bolts and lockwashers will be found in the bag tagged 8C-45. Refer to the figures on the next page for identification of parts and method of assembly.

Now assemble the front and rear channel members to the blower housing as shown, using three 1/2 x 1-1/4" long bolts, one 1/2 x 1" long bolt (inner forward position), flat washers and lockwashers. The channel with the offset splice is the forward channel.

Assemble the deflector to the lower side of the pulley shield as shown, using the fasteners provided.

The outer end of the auger is the end with double flighting. Remove the special heat-treated bolt from the inner end of the auger, coat the bore of the auger with grease, assemble the auger to the shaft extending out of the blower housing, and replace the special bolt.

8C-118

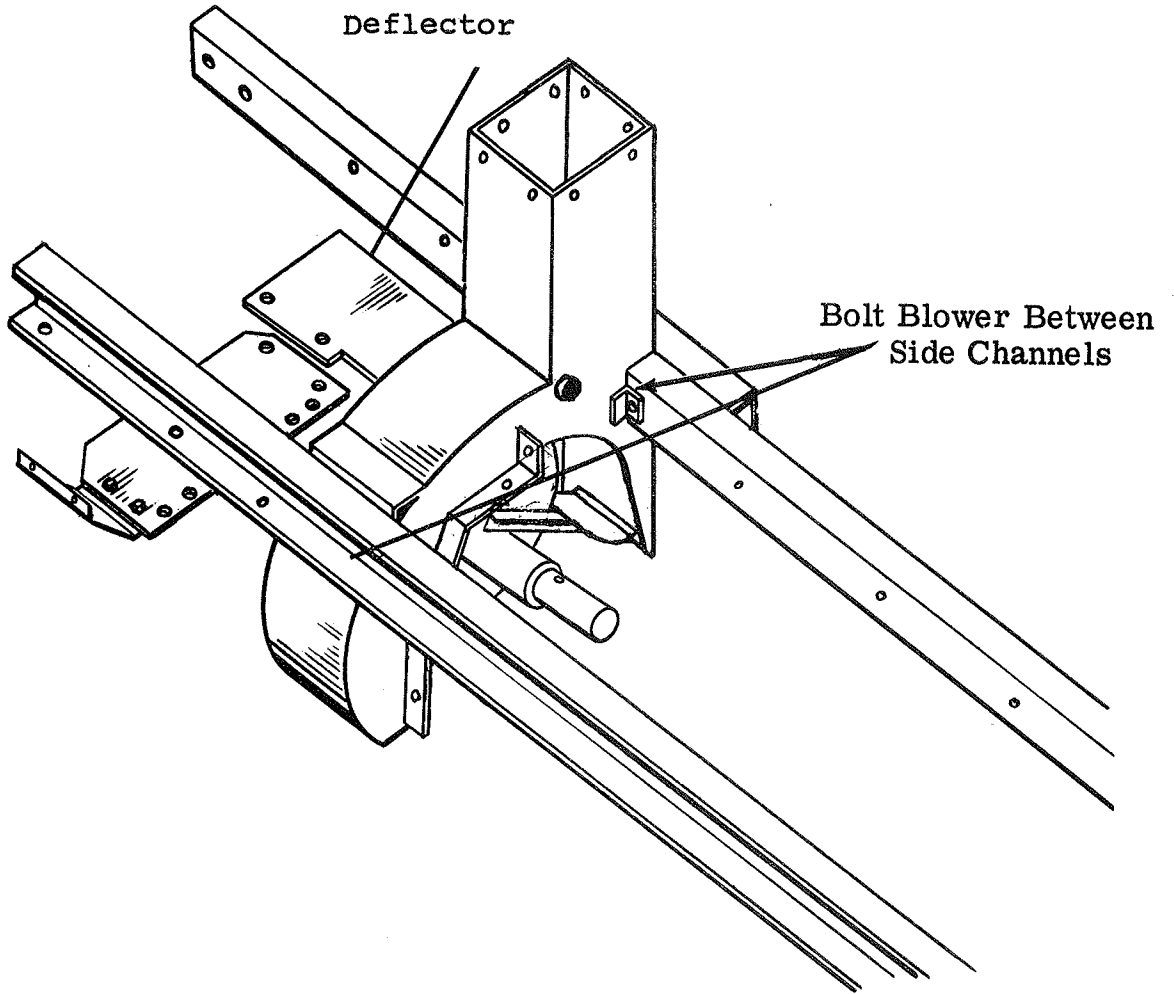

BLOWER MOUNTING

ATTACHING SHIELDS AND OUTER SUPPORT BRACKET ASSEMBLY

Position the rear auger shield against the blower face as shown in top view, next page, and bolt it inside the band using three $3/8 \times 3/4$ " long carriage bolts through the shield and band in the three lowermost holes with the heads of the carriage bolts toward the auger.

Position the blower shield between the rear auger shield and the forward frame channel as shown and attach to the rear auger shield using one $3/8 \times 1$ " long hex head bolt through the hole next to the blower, and to the forward frame channel with a $5/16 \times 3/4$ " long hex head bolt (head inside toward the auger).

Attach the forward shield support straps to the forward shield as shown, beginning at the outer end, using the $5/16 \times 1/2$ " hex head bolts provided, with the heads inside the shield. Position the forward shield between the rear auger shield and the forward frame channel and attach to the rear auger shield near the blower end, under the blower shield, using a $3/8 \times 7/8$ " long hex head bolt. Attach at the second hole from the outer end using a $3/8 \times 7/8$ " long hex head bolt.

Attach the forward shield support straps to the forward frame channel, using $5/16 \times 3/4$ " long hex head bolts.

Place the outer support bracket assembly into position as shown. Bolt the assembly in place using four $3/8 \times 1$ " long hex head bolts in the top positions. Bolt the web of the forward frame channel to the assembly, using one $1/2 \times 1-1/4$ " long hex head bolt. Attach the outer end of the rear auger shield inside the band using four $3/8 \times 3/4$ " long carriage bolts. Bolt both the shields to the angle clip on the inner side of the outer support bracket with a $3/8 \times 1$ " long hex head bolt.

8C-118

8C-118

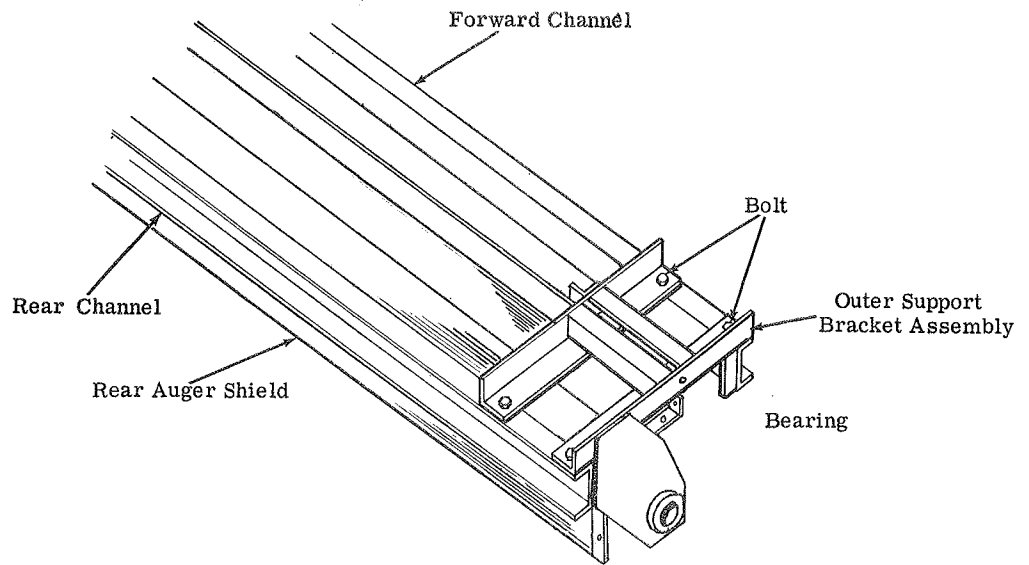
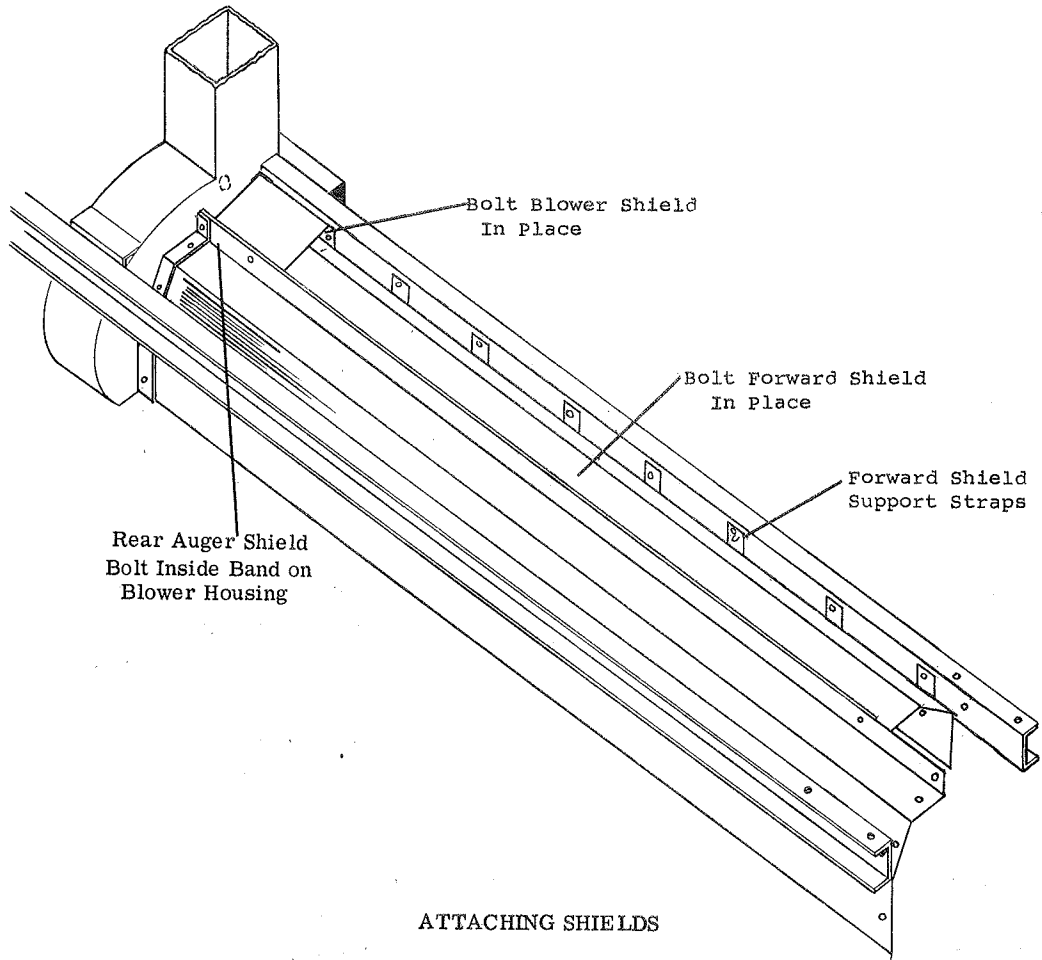

ATTACHING WALL WHEEL AND FROST WHEEL:

Place the wall wheel bolt, with adjusting screw in place over the bolt, up through the slot in the outer bearing bracket assembly, from underneath. The adjusting screw is inserted into the hole in the outer end of the bracket assembly and the locknut reinstalled. See top view on next page.

ON TOP of the slot, place the leveler plate with the Allen set screws outward. These set screws are used to level the wheel assembly during final adjustment of the silo unloader.

Place the bushing and wheel over the bolt, making certain the lube fitting is up, put on a 5/8" flat washer and follow with the lockwasher and nut.

Remove the special bolt from the outer end of the auger and coat the bore of the auger with grease. Install the frost wheel shaft through the outer bearing into the outer end of the auger, and replace the special bolt drawing the nut and jam nut up securely. See lower view on next page.

88-118

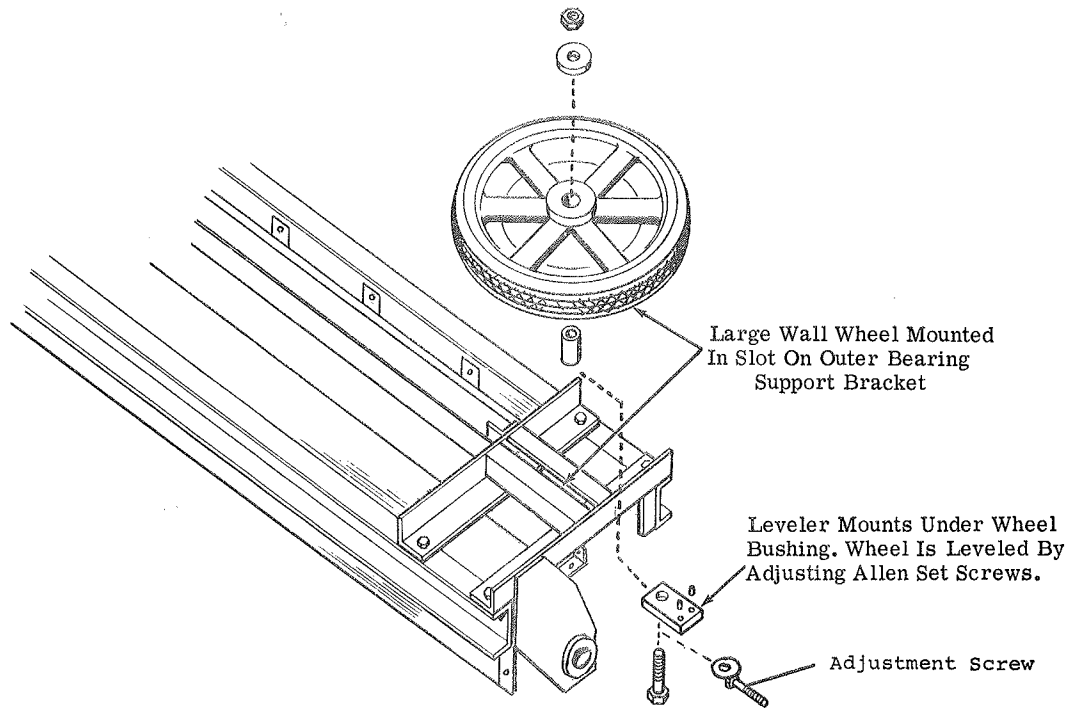

ATTACHING WALL WHEEL

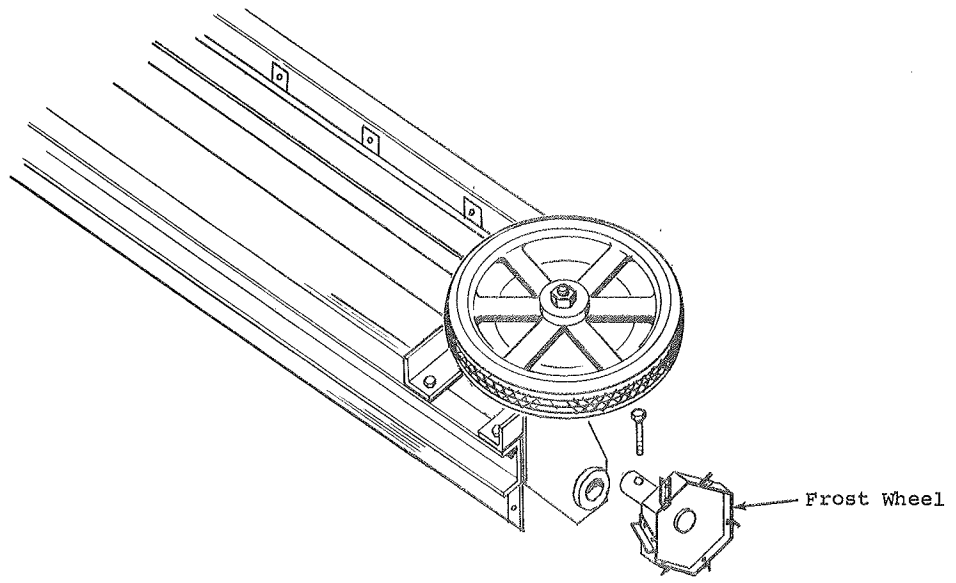

ATTACHING FROST WHEEL

8C-118

MOUNTING THE GEARBOX:

Position the gearbox mounting angles as shown, and bolt them in place loosely, using three $3/8$ x $1-1/4$ " long hex head bolts and one $3/8$ x $3-1/4$ " long hex head bolt (outer forward position).

Position the gearbox between the angles as shown, and draw the bolts down loosely.

Remove two lower bolts in gearbox cover and bolt gearbox to brace on blower housing assembly using bolts removed. Tighten these bolts securely.

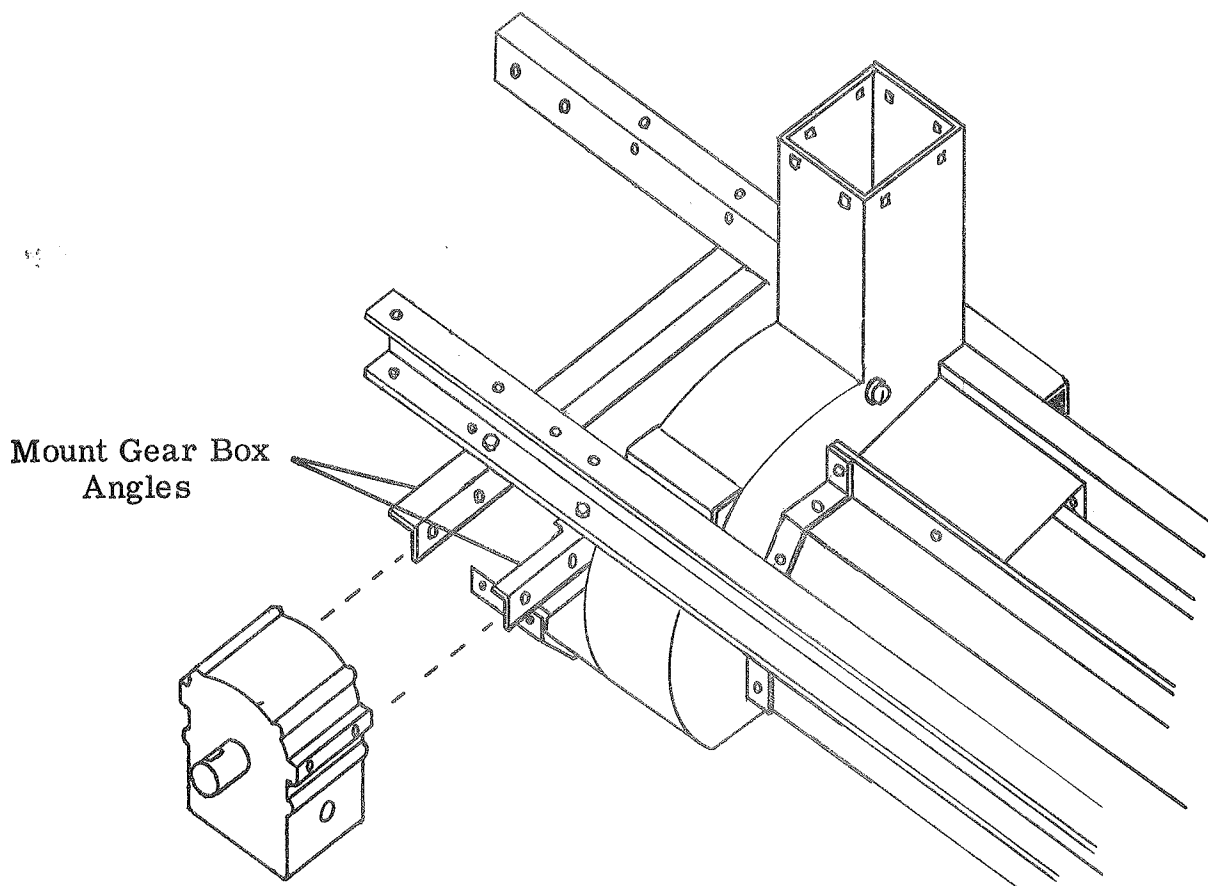

MOUNTING GEAR BOX

MOUNTING DRIVE WHEEL, SHAFT AND TIE ROD:

Assemble the universal joint to the drive shaft and the gearbox output shaft. Be sure the Woodruff keys are in place, and the universal joint is all the way on the shafts. Tighten the set screws tightly.

Attach the tie rod bracket, to the outer end of the rear channel as shown on the next page, using one 1/2 x 1-3/4" long hex head bolt and one 1/2 x 1-1/2" long hex head bolt.

Attach the tie rod to the tie rod connector, using a 1/2 x 2-1/2" long headed pin. Attach the tie rod connector to the tie rod bracket using a 1/2 x 2-1/2" long headed pin.

Your drive wheel assembly should be installed as shipped. Assemble to the drive shaft by removing the bolt in the shaft, aligning key in shaft with keyway in tube, inserting the shaft into the tube and reinstalling the bolt. Use only the bolt provided for this purpose.

Attach the other end of the tie rod into the bearing on the drive wheel assembly, using the headed pin provided.

8C-118

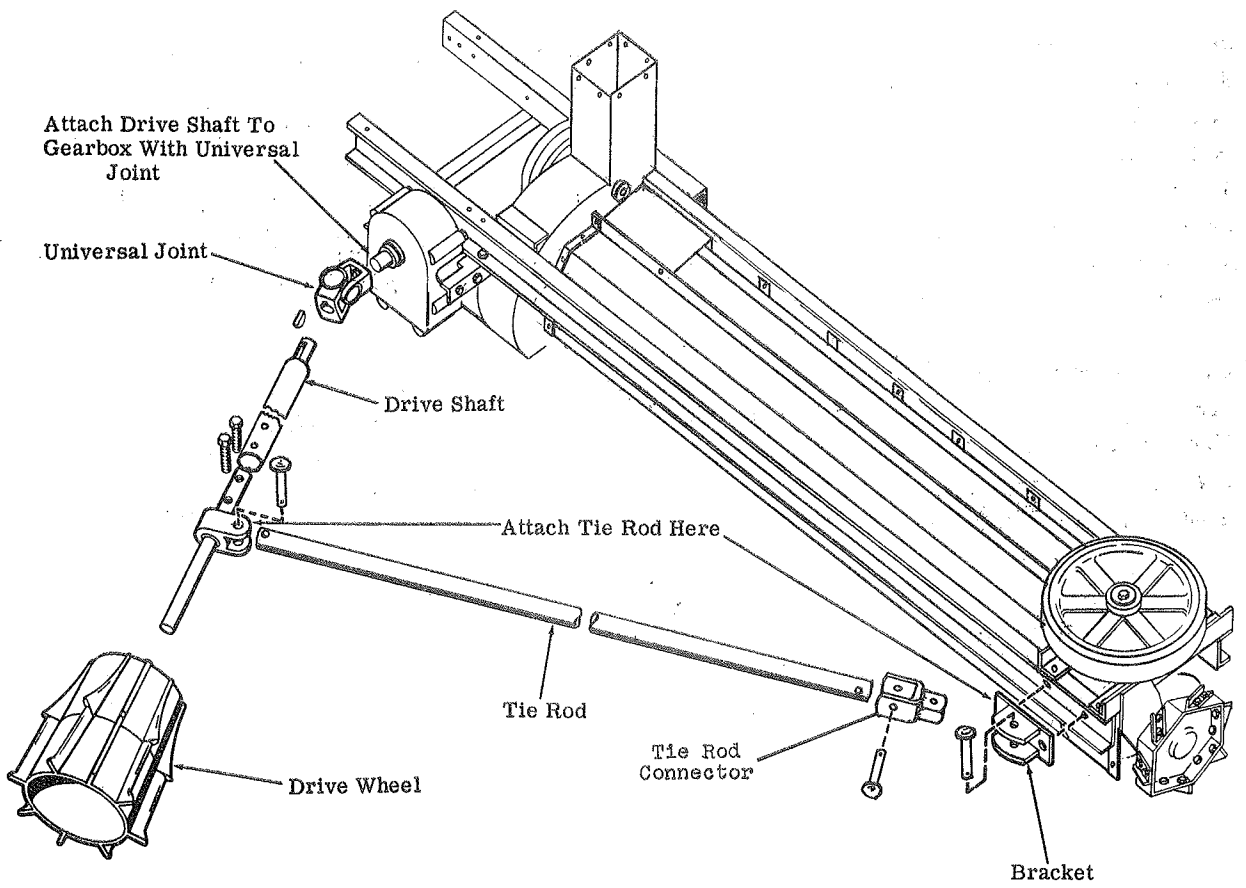

MOUNTING DRIVE WHEEL AND SHAFT

8C-118

MOUNTING SPREADER WHEEL AND ARM:

The spreader arm, together with its two braces, is mounted as shown. The brace angle is bolted under the forward channel in the last hole, using one 3/8 x 1-1/4" long hex head bolt, and the support brace assembly is bolted to the inner side of the lug on the blower housing, using a 3/8 x 2-1/4" long hex head bolt. The base of the spreader arm is bolted to the front frame with a 1/2 x 1-1/4" long hex head bolt and lockwasher.

THE DISTANCE FROM THE CENTERLINE OF THE BLOWER TO THE OUTSIDE OF THE RUBBER TIRE SHOULD BE SET TO ONE INCH LESS THAN THE RADIUS OF THE SILO. (For example, 95" in a 16' silo.) IF THE SILO IS OUT-OF-ROUND, SET IT 1 INCH LESS THAN THE SHORTEST RADIUS.

8C-93

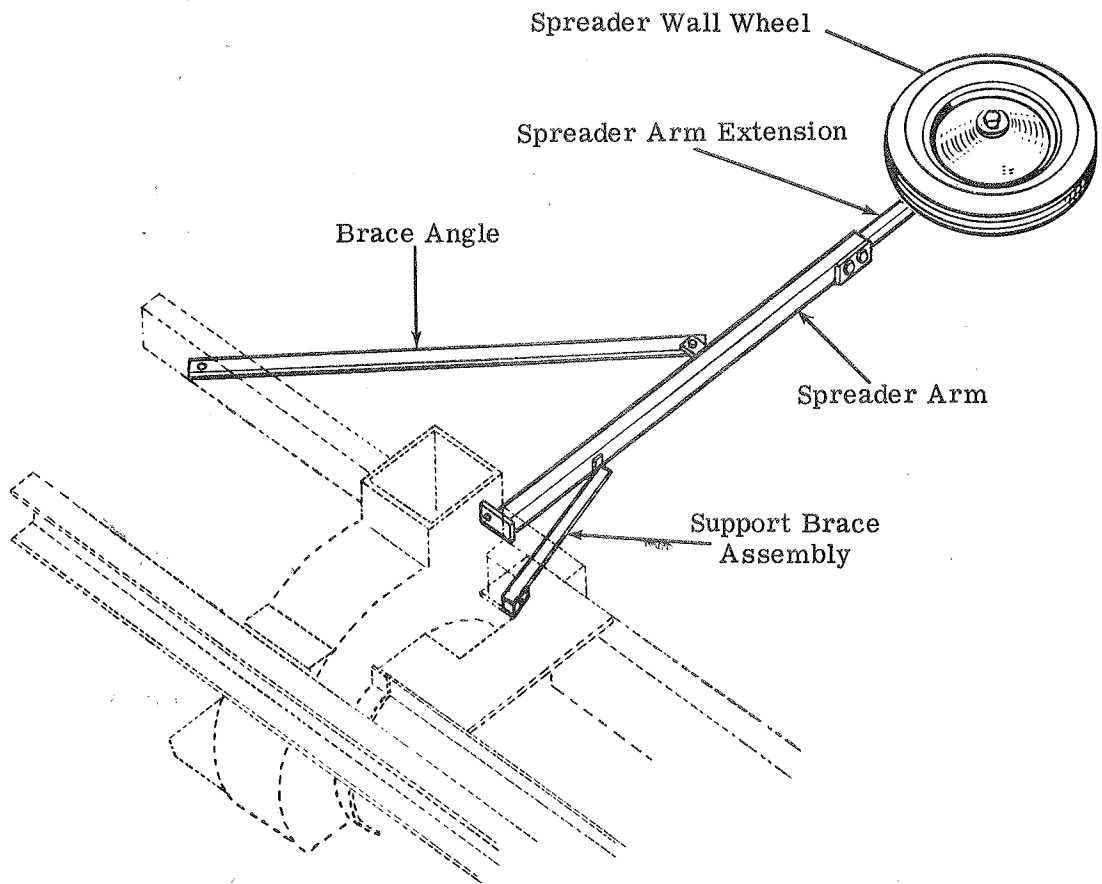

MOUNTING SPREADER WHEEL AND ARM

TRANSITION, HANGER & TORQUE ARM ASSEMBLY:

The transition assembly, which couples the rotating and non-rotating parts of the machine, will be found in its cardboard carton. The longer extension of this assembly is positioned on the blower output stack, so that the name tags face outward, and bolted in place, using eight 5/16 x 3/4" long carriage bolts. The hanger assembly is attached to, and bolted firmly in place on, the upper, shorter, section of the transition assembly using four 3/8 x 1" long hex head bolts. At this point, check the transition assembly to be sure that the rotating parts turn free of the nonrotating parts.

The four parts which make up the torque arm assembly may now be attached in place on the hanger assembly. The function of the torque arm assembly is to hold the nonrotating parts of the silo unloader in place and make certain that the discharge spout is always directed at the chute opening.

The assembly is telescoping, and the torque arm must be free to move at all times as the unloader travels around the silo. The tube on the torque arm is to project downward and is intended to support the outer section of the spout.

Bolt the torque arm yoke to the inner surfaces of the hanger assembly, using the fasteners attached, less two 1/2" flat washers.

Place the discharge tube on the upper transition and bolt it in place, using bolt and locknut provided, in the centered set of holes. The upper section of the spout can be attached to the lower in two locations. The views at top of the opposite page shows which mounting holes to use for each size machine, when mounting on discharge tube and when attaching spout support straps.

Attach the support frame to the spout support straps. Adjust the support frame after the door bracket has been installed. The spout should aim at the door above the one on which the door bracket is attached, except at the very top of the silo where it may be necessary to use the same door. In the latter case, move the support frame down on the torque arm to the upper set of holes.

8
|
|
|
C
8

12' Spout



View showing correct holes to use for Yoke and lower spout connections

14'-20' Spout

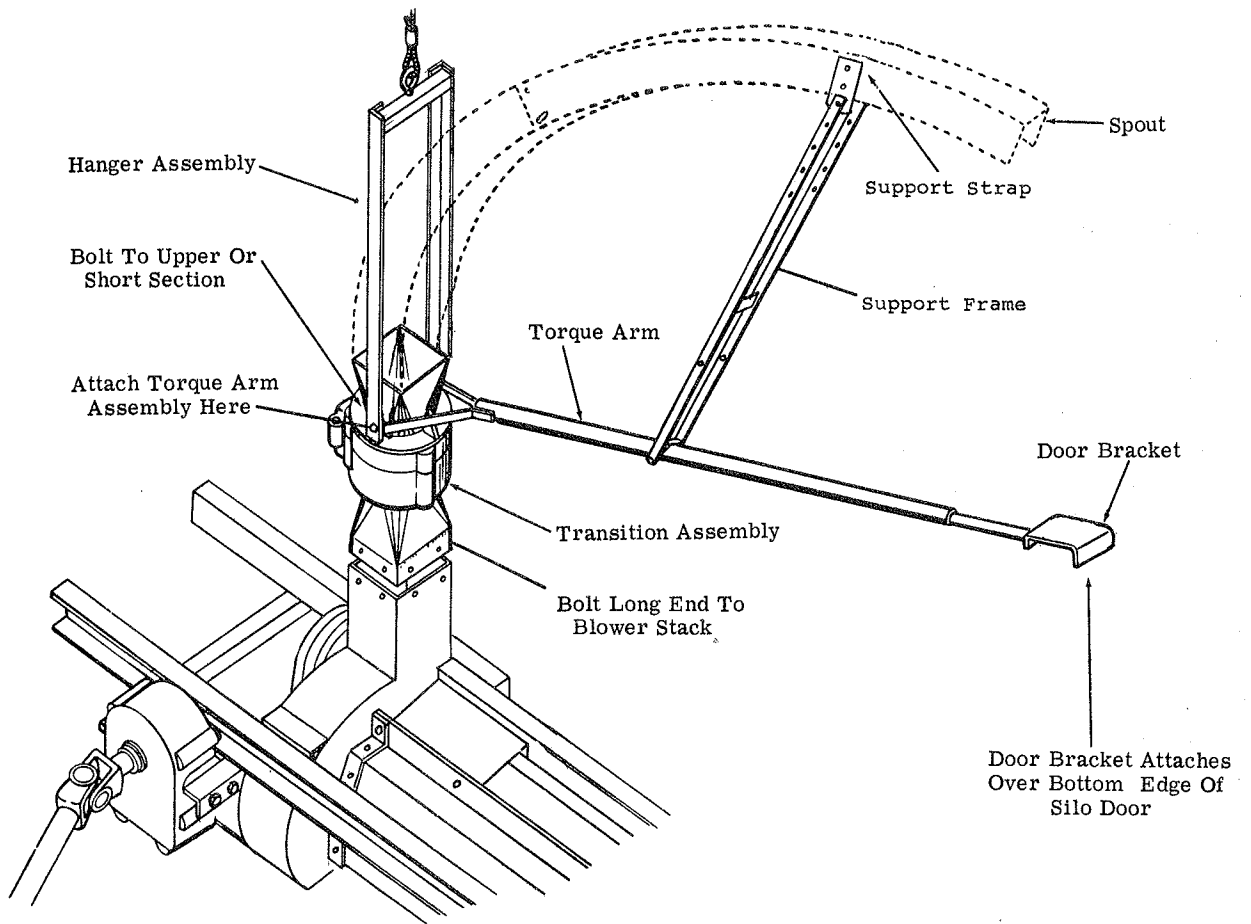
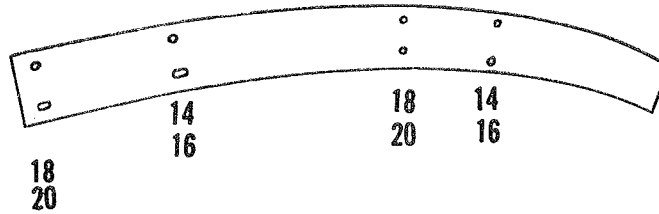

HANGER AND TORQUE ARM ATTACHMENT

MOTOR AND BELT IDLER MOUNTING:

The motor may now be removed from its carton. Save the wiring tag. On the motor shaft, place the small sprocket closest to the motor with its hub outward. Allow enough clearance between the sprocket and the motor end bell to clear the chain. Then install the 2 groove V-pulley, but do not tighten set screws yet.

Assemble the four mounting plate adjustment bolts in the mounting plate. The adjusting bolts are 1/2 x 3" long with 2-1/2" of thread. They are found in the bag assembly 7C-458, and are installed head down on the blower side, and head up on the inner side, use two jam nuts on each of the inner bolts, one above and one below the flange channel.

Position the motor base plate between the frame channels. The slots in the side flanges of the base plate will align with holes in the frame channels. Place 1/2 x 1-1/4" bolts through these, with flat washers over the slots, and lock-washers and nuts, but do not draw up tight.

The motor is now mounted on its base plate, and tightened securely, using four 3/8 x 2" hex head bolts and two flat washers for the 5 H.P. motors, or four 1/2 x 1-3/4" hex head bolts for the 7-1/2 H.P. motors. Use four 1/2" thick spacing blocks between the base of the 5 H.P. motor and the motor base plate.

Attach the belt idler assembly to the upper flange of the rear frame channel as shown, using two 3/8 x 1-1/4" hex head bolts.

Notice the guard, and its mounting holes. Do not put it in place until idler sprocket and chains have been installed as described on following page. Do not put V-belts over motor pulley at this time.

Your electrician may make the motor connections at this time, following directions on the tag supplied with the motor. After the pulley guard is installed, be sure it is clear of the electric cable.

8C-118

8C-118

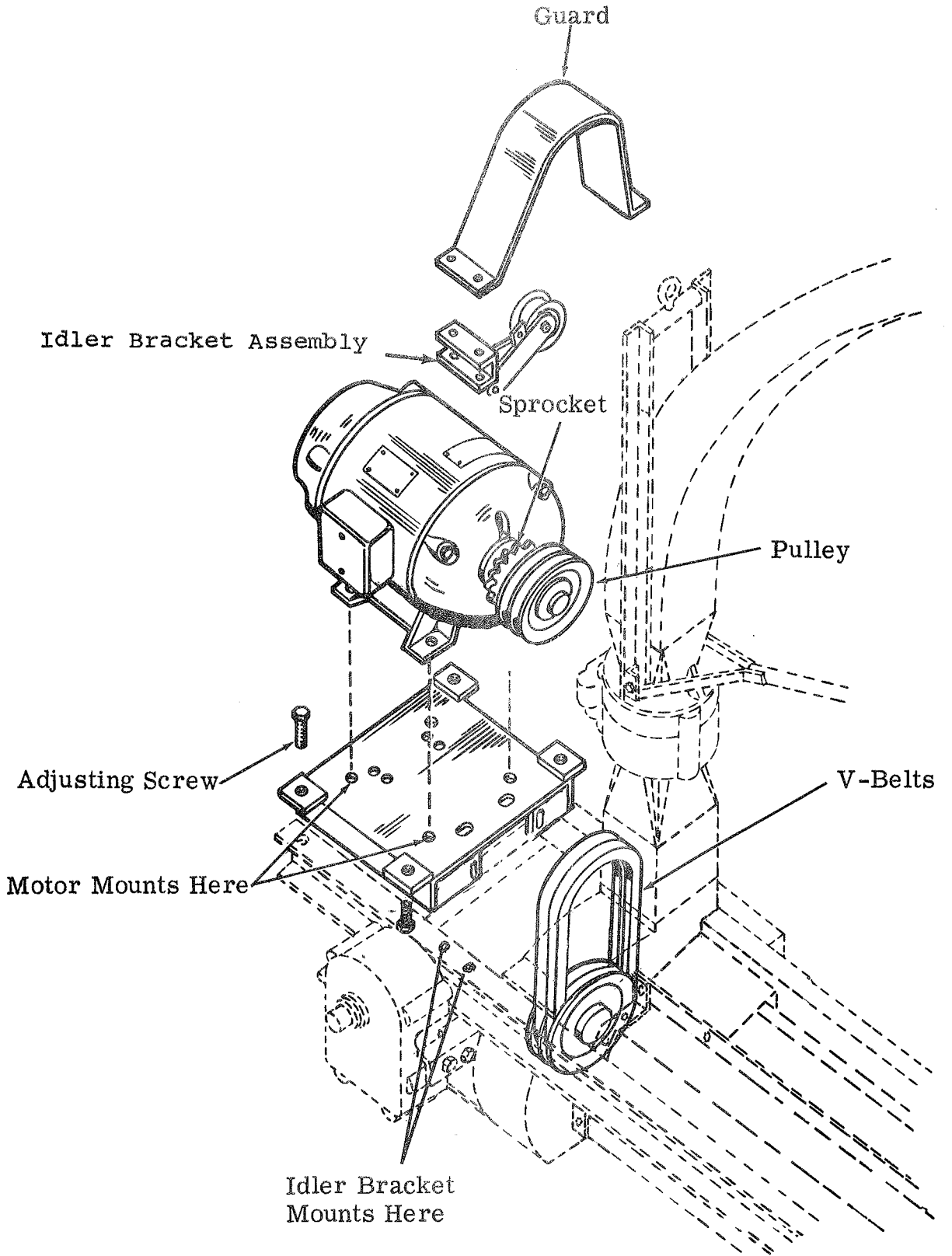

MOTOR MOUNTING

IDLER BRACKET, HOIST CABLE, AND BALANCE ARM:

Study the top view at right. Select the bracket and sprocket assembly from the bags of parts.

Install this assembly to the slotted plates under the motor base plate, with the set screw down, using two 1/2 x 1-3/4" long hex head bolts, with flat washers over the slots.

Put the chains over their respective sprockets and fasten them. Place the V-belts over the motor pulley, check the alignment of all sprockets and pulleys. The alignment, if necessary is made by moving the sprocket and pulley on the motor shaft. When the sprockets and pulleys are aligned, tighten all set screws securely.

Now adjust the motor base plate upward until the chains are tight, making certain that the idler bracket is all the way forward in the slots.

Lock the base plate in position with the 4 side bolts, and tighten jam nuts on adjusting screws, MAKING CERTAIN THAT BASE PLATE ADJUSTING LUGS ARE ALL THE SAME HEIGHT ABOVE THE FRAME CHANNELS.

Tighten the V-belts by taking up on the idler adjusting bolt. The belts should be just tight enough so that they will deflect 1/2" on the side away from the idler when pressed in by hand.

Now install the chain and belt guard using four 3/8 x 3/4" long hex head bolts.

Put the hanger eye bolt through the pipe in the top of the hanger, and draw up two lock nuts.

Your cable has been attached to the eyebolt at the factory because this is a very important assembly. The cable clamps MUST be installed with the U-bolts over the short side of the cable. Follow closely the instruction tag attached to the cable assembly.

Bolt the balance arm to the inner end of the forward channel, using two 1/2 x 1-1/4" long hex head bolts. You may place the balance weight on it temporarily, but correct balancing will be discussed in "Adjustments" section of this book. On the 18' and 20' unloaders a special stiffening bracket is provided for mounting between the balance arm holes on the forward frame channel and the inner motor base plate hole on the rear frame channel.

8
11
8

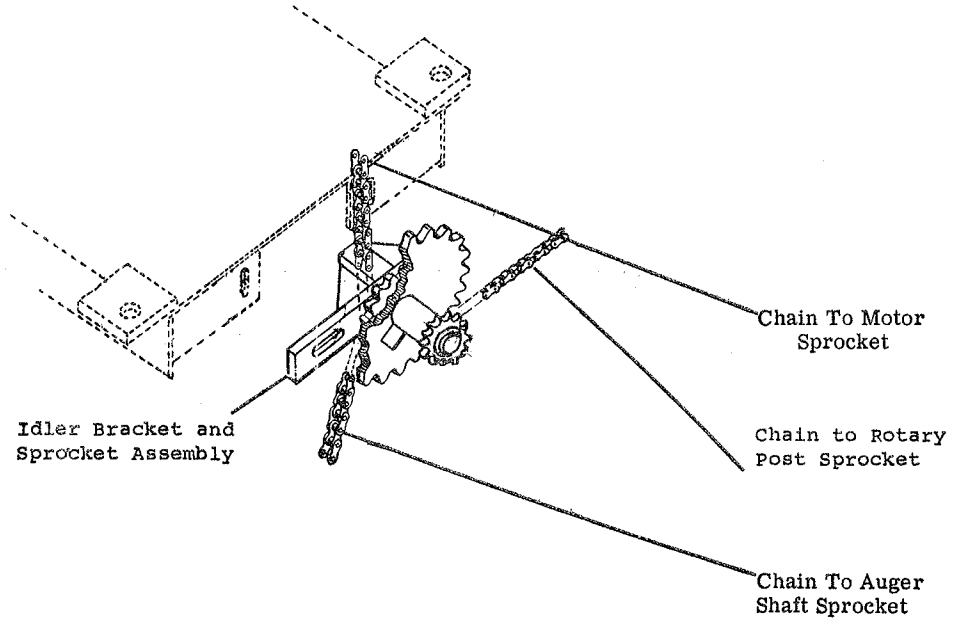

IDLER BRACKET AND SHAFT MOUNTING

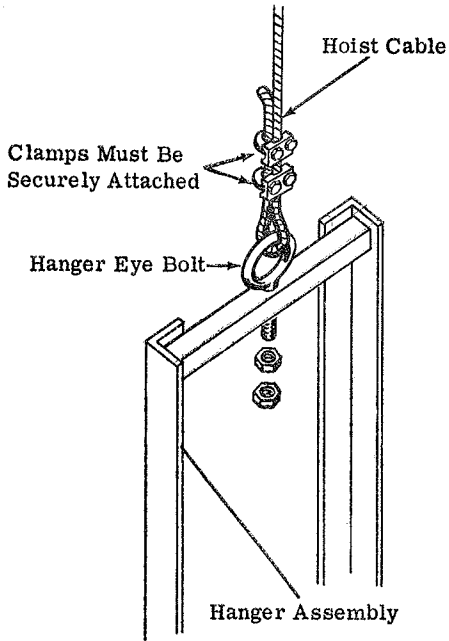

ATTACHING HOIST CABLE TO HANGER

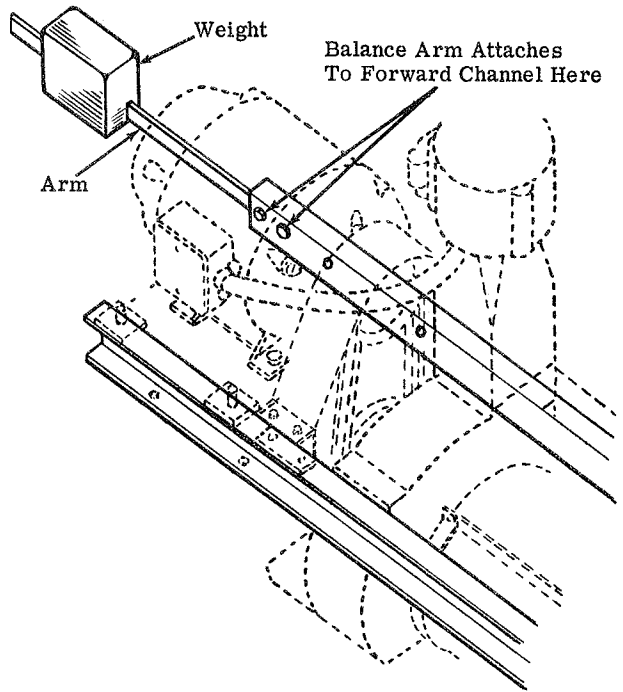

MOUNTING BALANCE ARM

LUBRICATION:

It is important that your Silo Unloader be properly and regularly lubricated. Figure on opposite page shows details and locations of greasing and oiling points. It is recommended that lubrication be performed at intervals of 10 days to 2 weeks. For many users, this corresponds to about the time an additional door is removed, and makes a convenient time to perform the service.

Carefully lubricate before storing and again before placing in service after storage. After storage, check all rotating parts to be certain they will rotate freely.

BE SURE TO GREASE LIBERALLY THE FOUR FITTINGS ON THE CLAMP RING. THE ENTIRE WEIGHT OF MACHINE IS SUSPENDED HERE. THIS IS ESPECIALLY IMPORTANT IN WINTER, TO KEEP THE BEARING FROM FREEZING.

THE OUTER BLOWER SHAFT FITTING ALSO NEEDS MUCH GREASE. THIS ONE IS OFTEN OVERLOOKED---DON'T MISS IT.

COAT ALL EXPOSED SHAFTS WITH GREASE IF THE UNLOADER IS DISASSEMBLED FOR MOVING. IT IS ESPECIALLY IMPORTANT TO GREASE AUGER BORES BEFORE ASSEMBLING TO MATING SHAFTS.

8C-118

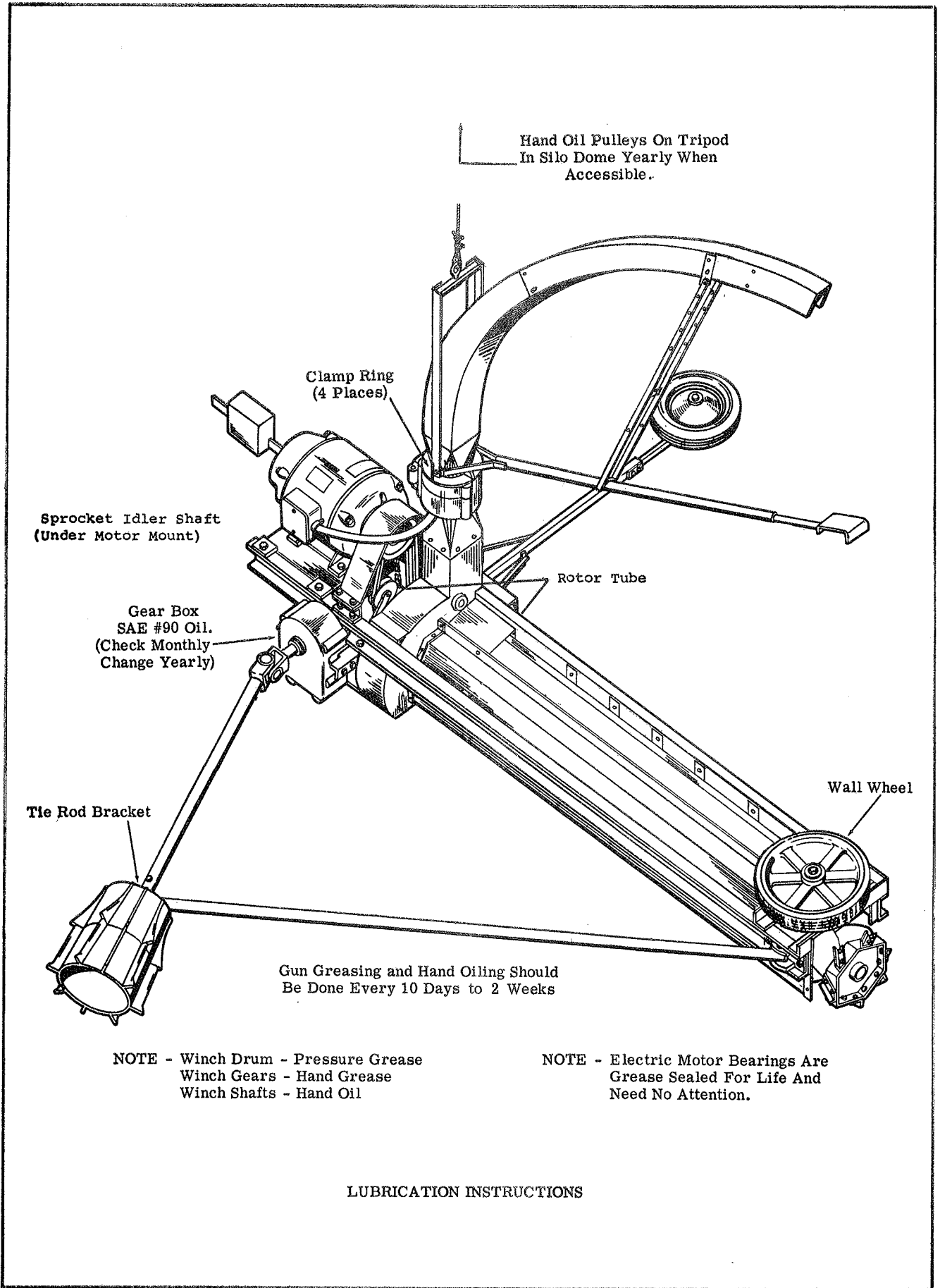

Hand Oil Pulleys On Tripod
In Silo Dome Yearly When
Accessible.

Clamp Ring
(4 Places)

Sprocket Idler Shaft
(Under Motor Mount)

Gear Box
SAE #90 Oil.
(Check Monthly
Change Yearly)

Rotor Tube

Tie Rod Bracket

Wall Wheel

Gun Greasing and Hand Oiling Should
Be Done Every 10 Days to 2 Weeks

NOTE - Winch Drum - Pressure Grease
Winch Gears - Hand Grease
Winch Shafts - Hand Oil

NOTE - Electric Motor Bearings Are
Grease Sealed For Life And
Need No Attention.

LUBRICATION INSTRUCTIONS

ADJUSTMENTS AND OPERATION:

Certain simple adjustments must be carefully made to insure proper operation of your Forage-Master Unloader.

CENTERING:

The Spreader Wall Wheel (page 21) must be properly set to ONE INCH LESS THAN NARROWEST RADIUS OF SILO. THIS IS MEASURED FROM CENTERLINE OF THE BLOWER, NOT FROM CABLE ATTACHING POINT.

OUTER AUGER WALL WHEEL:

Position this wheel so the Frost Chipper Knives just clear the silo wall. Final adjustments with the Leveler Screws under the wheel will be made after balancing.

BALANCING:

This adjustment is perhaps the most important in obtaining satisfactory operation.

In addition to placing balance weight on Balance Arm, it may also be placed on the rail above the rear Auger Shield.

Balancing is necessary because of the different combinations of Motor and Auger weights on the various sizes of unloaders.

The machine is to be balanced so as to form a cone in the silage while running. This cone is to be formed with the center about 2 inches higher than the outside. The machine should be just slightly heavy out at the end of the Auger.

On smaller sizes of unloaders, the balance weight usually belongs out in front of the blower. On 14' machines, the weight may not be necessary at all. On larger machines, the weight will be found back on the Balance Arm.

The proper place simply must be found by trial and error, and is correctly done when the 2" high cone is formed in the silage.

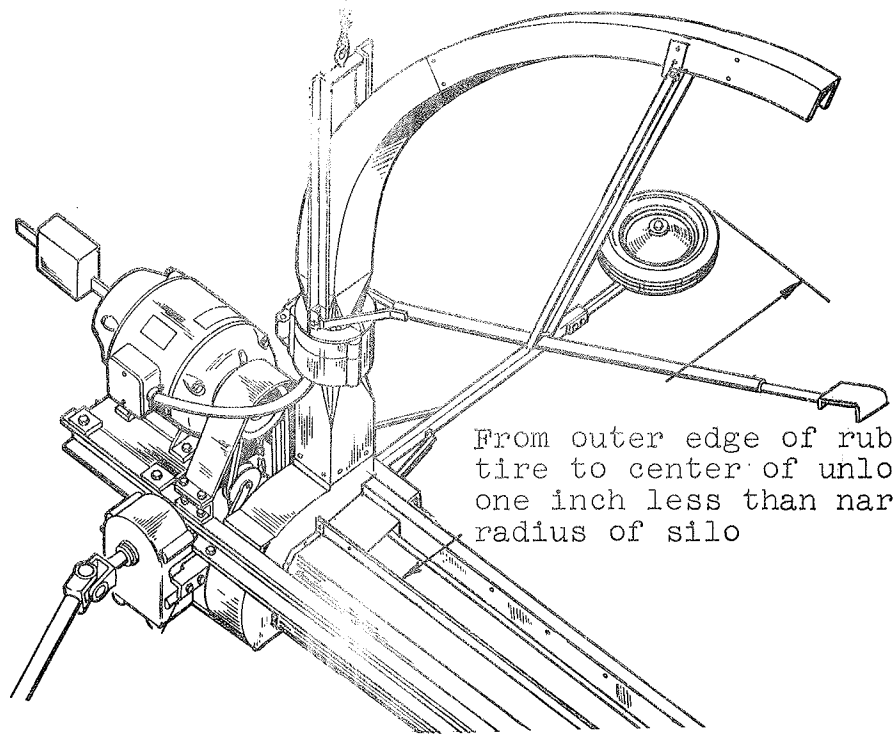

From outer edge of rubber tire to center of unloader - one inch less than narrowest radius of silo

PROPER CENTERING IN SILO

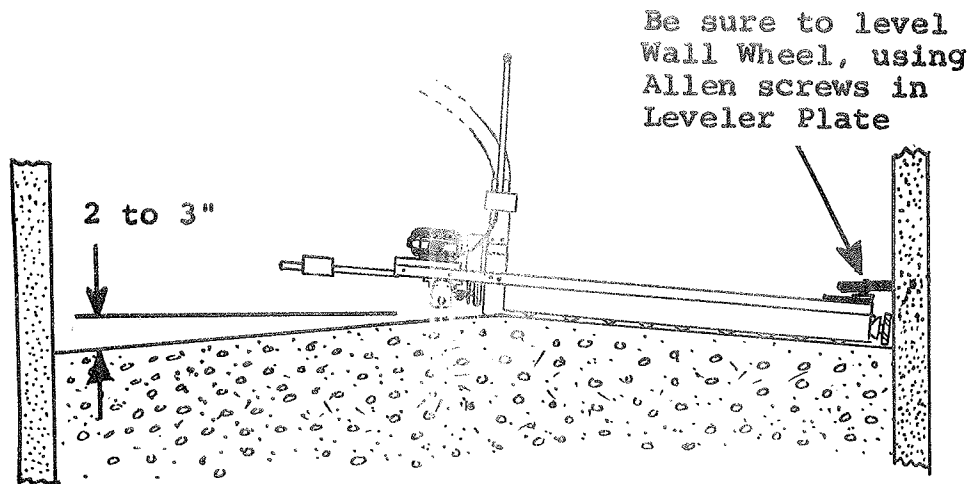

CORRECT BALANCING AND CONE FORMATION

It is absolutely necessary that the silo wall be free of any obstructions projecting inside. This means that no cleats of any kind are permissible on the chute doors. If cleats are already on doors, and cannot be removed, adjust the location of the wall wheel so the frost chipper wheel is far enough from the wall to clear cleats. Any holes in the silo wall should be filled or patched as they are uncovered, for if the machine jams in the hole, motor damage will result. The machine must be free to turn, easily and smoothly, around entire circumference of the silo at all times.

The motor may now be started, while the machine is in a suspended position, to be sure that it will rotate properly and run freely. If everything seems to be in order, lower the machine slowly into the silage until it begins to eject material into the chute. When making any adjustments, be certain the three prong plug is disconnected, so that it may not be turned on accidentally.

UNLOADER OPERATION:

When your unloader has been properly installed and checked to see that all working parts are smoothly operating, it may be placed in service at once. If the silage level is uneven and rough, level it off as much as possible before beginning operation. **UNDER ALL CONDITIONS, THE MACHINE SHOULD BE STARTED WHILE SUSPENDED ABOVE THE SILAGE AND ENTIRELY CLEAR OF IT.** As soon as the motor has come up to speed, the machine may be lowered slowly onto the silage and material will begin to come down the chute.

The machine requires approximately 1-3/4 minutes to make a complete revolution in the silo. In a new installation, the first few revolutions will usually be used in leveling the silage. At this time, the balance weight position may be adjusted to provide a slight cone effect with the high spot at the center of the silo. The operator may walk slowly around the silo as the machine turns, checking the fit of the two wall wheels at the silo wall. Minor adjustments may be made at this time.

The machine is operating at capacity when the motor is drawing its rated electrical current (amperes). Without the installation of an ammeter in the line, (available as an accessory), the equipment may be judged to be operating at normal capacity when the motor begins to sound as if it is slowing down very slightly. At this point, the motor is probably slightly overloaded and the machine should be raised very slightly to relieve the load. A steady, heavy stream of silage coming down the chute indicates satisfactory operation.

80-118

When the desired amount of silage has been brought down the chute, raise the machine from the silage bed while it is still running. This will permit the blades to clear themselves of silage and the machine may be shut down. During periods when it is not running, it should always be suspended above the silage and not permitted to rest on it. In severe winter weather, if the machine should freeze down to the silage, damage to the motor may result when an attempt is made to start operation.

TO REPEAT, ALWAYS REMEMBER, START AND STOP THE MACHINE WHILE SUSPENDED ABOVE THE SILAGE.

FROZEN SILAGE:

One of the biggest advantages in the use of a Brillion FORAGE-MASTER Silo Unloader is that, when silage is frozen, the machine may be equipped with cutting knives mounted on the auger to continue a steady feed and to mix the frozen material with the unfrozen. The silage, as it comes down the chute, is well broken up and is without lumps and chunks of any kind. When severe weather is coming, mount the knives on the outer end of the auger of your machine. SEE PAGE 34 FOR PROPER METHOD OF INSTALLING KNIVES. The frost wheel should operate approximately 1/4" from the silo wall and will keep the wall clear of frozen material.

Silo Unloaders perform differently in the different types of material from which silage is made. Operation in grass silage generally brings a reduced output as compared to corn silage. The output of the machine will also vary as it moves down through the silo from top to bottom because of the difference in density and packing of the material. Gummy and sticky materials will require more careful handling of the machine than in materials which are somewhat dry and rather solidly packed. On the other hand, material very heavily packed or in frozen condition will also result in somewhat reduced output as the amount of effort required to cut the material loose is increased. Care should be used in loading the machine to capacity until the user feels he has gained enough experience to know when the motor is operating at capacity but not at overload. Here again, an ammeter is your best motor protection.

As the silo unloader moves down through the silo, it will be necessary for the operator to enter the silo occasionally to remove an additional door and to readjust the connecting point of the torque arm and the aim of the discharge stack to the next lower chute door. When storing doors which have been opened, and are to be placed or hung somewhere in the chute, be certain that they cannot fall inside the silo where the unloader will encounter them in its travel.

811-38

Foreign material of this type or wrenches, fasteners, screw drivers, etc. may cause severe damage if encountered by your unloader.

Within a short time, the operator will gain the experience necessary to know just how often the torque arm will have to be adjusted and additional doors removed. Lubrication of the unloader can occur at this time. An occasional check of the unloader while in the suspended position to be sure that all fastenings are tight and that the unloader is operating smoothly will avoid future troubles.

FILLING THE SILO:

When the silo is empty, the unloader may be drawn to the top and allowed to remain suspended. Many operators prefer to tie the unloader to the tripod legs with heavy rope to relieve the cable and winch of the strain of storage for summer months. When the unloader is to be suspended and stored in such a manner, remove the drive wheel, the drive shaft, and the tie rod. The hanger may be removed and the "short hanger" installed in its place. This permits the unloader to be drawn higher up into the tripod. It will be necessary to remove the spout and spreader assembly also. These parts, because they are suspended on pivoting members, will not store properly when the unloader is held in a suspended position. Many operators also prefer to remove the motor and store it elsewhere rather than to have it in the silo. The motor, however, is a drip-proof motor and such storage is not absolutely necessary.

When the silo is filled, many operators feel that the unloader hanging suspended in the dome interferes with the proper distribution of silage from the blower pipe. Whether or not this problem develops, depends a great deal on just how the operator handles his silo filling, how full he wishes to fill the silo and the location of the filler hole or filler opening with respect to the suspended unloader.

In spite of the amount of work involved, many operators prefer to remove the unloader entirely from the silo, once the silo is empty.

8C-118

8C-118

The silo may then be filled completely to the dome if necessary, which will usually leave sufficient room at the top once the spoiled silage is cleared to permit the assembly of the machine. Assembly of the machine under these conditions usually amounts to no more than a half a day's work for two men.

The matter then, of what to do with the machine during silo filling time is entirely at the discretion of the operator.

88-1188
MAINTENANCE:

At least once a month during operation, the owner should check the machine carefully for loose bolts, etc., V-belt adjustment, and drive chain adjustment. Raise the unloader, and turn the motor pulley over by hand to check for binding.

At the beginning and end of each service year, perform the lubrication described above, check fasteners as mentioned in previous paragraphs, and inspect cable for corroded, worn or frayed spots. Replace cable if necessary. Check electrical cable for worn insulation. Check brushes in commutator assembly. Careful operation and maintenance as described will help you get years of trouble-free performance from your FORAGE MASTER Unloader.

INSTALLATION OF KNIVES ON AUGER

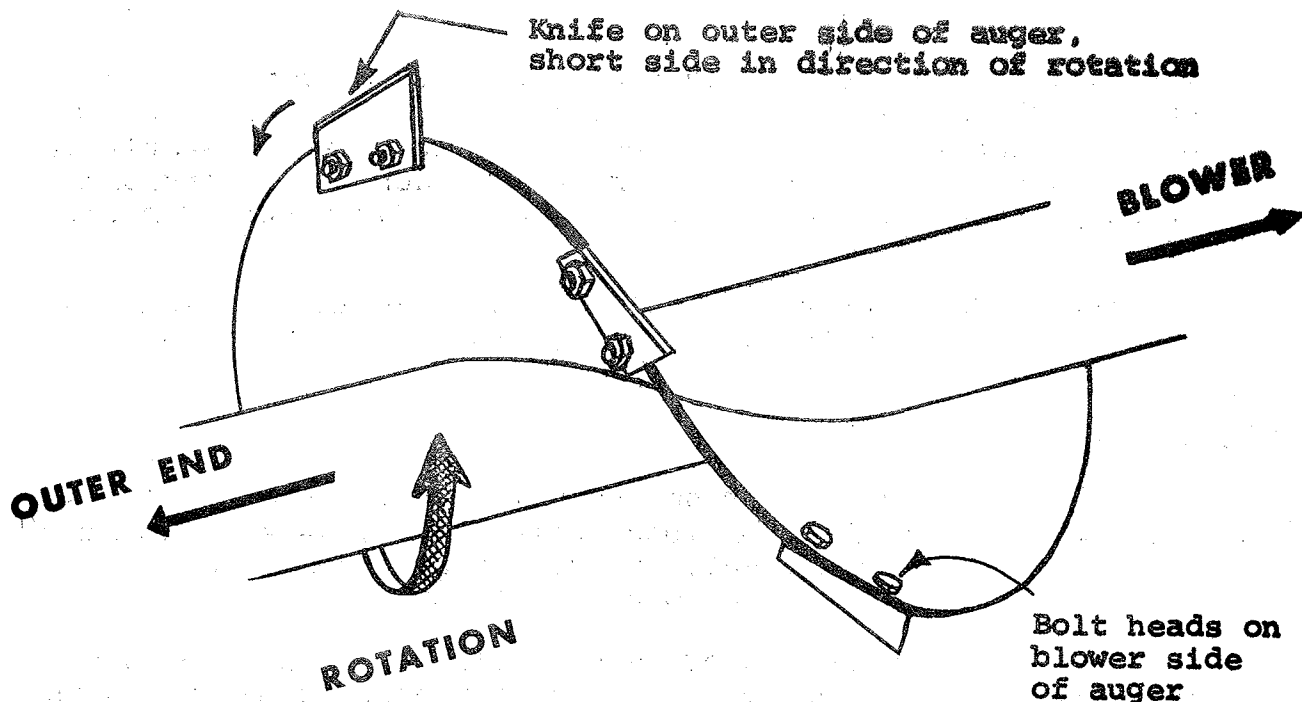

Knives are installed on Silo Unloader auger to cut loose frozen or hard-packed material.

They should be installed exactly as shown above, with the knife on the outer face of the auger, short side in direction of rotation, and bolt heads toward blower. In this way the knife will slice instead of chop, and will not entangle loose material.

Knives should be used only when necessary. In frozen silage put knives only on that portion of auger which rides over frozen material. On hard packed corn, or in poorly shredded grass silage, put as many knives on as required to loosen material.

On some types of grass silage it is desirable to use a knife in every other set of holes and use them all the way back to the blower.

WIRING INSTRUCTIONS - BRILLION SILO UNLOADER

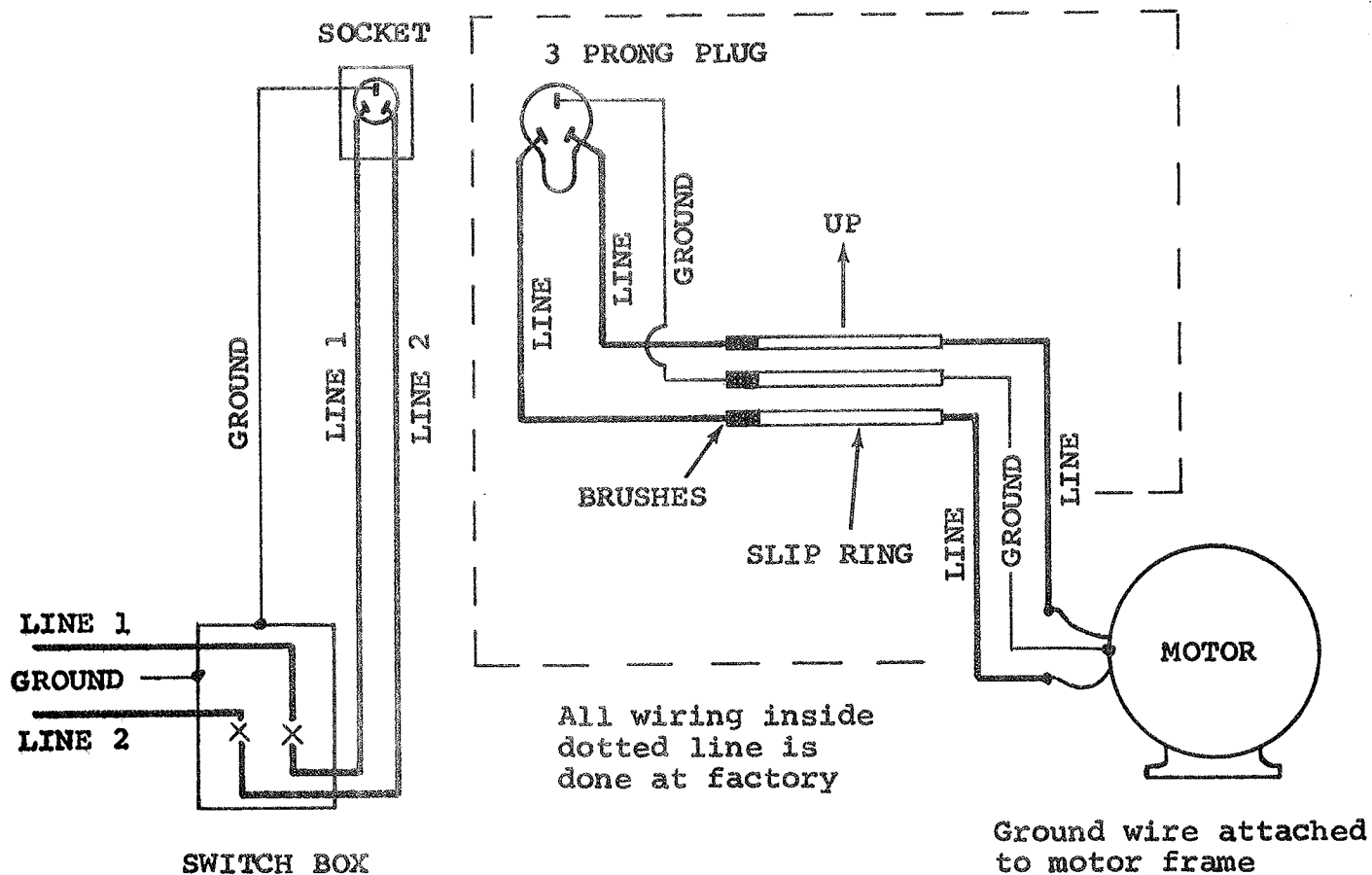

IMPORTANT

A LICENSED ELECTRICIAN SHOULD DO YOUR WIRING, AND SHOULD CHECK VOLTAGE AT THE MOTOR AFTER WIRING IS COMPLETE. IF VOLTAGE FALLS BELOW 210 WHEN MOTOR IS STARTED, NOTIFY YOUR POWER COMPANY AT ONCE.

Two wiring codes are in common use in the United States. Be sure to notice carefully the colors of the wires in each cable and wire accordingly.

IN RED BLACK WHITE, WHITE IS GROUND

IN BLACK WHITE GREEN, GREEN IS GROUND

You may find both types of cable in your installation. BE SURE TO USE PROPER WIRE FOR GROUND, AT BOTH ENDS OF CABLE.

Silo Unloader Trouble Shooting Sheet

(A) Motor Fails to Start or Come Up To Speed

- (1) Be sure motor shaft can turn - raise machine and check for binding or jam in Blower or Auger.
- (2) Check fuses and switchbox overload heater element.
- (3) Check all wiring and connections.
- (4) Check brushes in slip ring assembly.

(B) Machine fails to feed

- (1) Be sure discharge stack is aimed at chute door.
- (2) Check fan belt tightness.
- (3) Check to see if drive wheels are turning. If not:
 - (a) Check drive wheel keys.
 - (b) Check universal joint and keys.
 - (c) Check Lovejoy coupling for open or broken condition.
 - (d) Check auger drive chains for looseness or breakage.
 - (e) Check worm gearbox for internal damage.
- (4) If drive wheels are turning, but slip in silage and bury themselves:
 - (a) Check silo wall for obstruction which could stop auger.
 - (b) Check for soft spots in silage. If found, feed machine lightly until soft spot is cleared.
 - (c) Check machine balance. Improper placement of balance weight will cause auger to be too heavy or too light. Too light an auger balance is indicated by machine jumping in silo, or attempting to climb wall. Blower will dig in and generally form a funnel cone in silage with center low. Move balance weight forward toward wall, out in front of blower if necessary. (particularly on 12' machines) weight can slide on rail centered above auger (no. 117 in repair parts booklet) as well as an angle projecting behind blower. Too heavy an auger is indicated by a steep cone formation (center high) in silage, tendency for machine to climb wall, and a general hard-working overload condition. Move weight rearward to balance.

- (d) If frost cutting knives are on auger, and no frozen or solid packed condition exists, remove the knives.
- (e) If all above conditions are corrected, and machine still fails to feed properly, but does not plug blower, it is likely that it is simply being fed into silage faster than its capacity will permit. Slow down the feed rate.

C. Blower Plugging

This condition sometimes occurs when silage is very wet, and/or of a stringy or shredded nature. The condition is often made worse if the operator has a tendency to feed rather heavily. Use of knives on the auger, if not actually required for frozen or hardpacked silage, will also aggravate blower plugging.

To relieve the problem, remove knives if not required, check machine balance, and feed more slowly.

D. Lack of Power

1. Check for proper wiring
 - (a) Proper transformer $7\frac{1}{2}$ KVA
 - (b) Proper Switchbox
 - (c) Proper wiring to silo - at least number 6
 - (d) Follow motor wiring code
2. Check power at motor
 - (a) 220 to 240 volts - No less than 208
3. Be sure machine is started when empty and raised from silage.

CHECK WITH POWER COMPANY

E. Wall Wheel Adjustment

1. Wall wheel adjusted so frost wheel clears wall by about $\frac{1}{4}$ inch.

F. Winch & Tripod Installation

1. Grease winch worm and gear
2. Coat cable with grease
3. Keep winch and switchbox located together and free from falling silage.

