

SETTING-UP AND OPERATING MANUAL

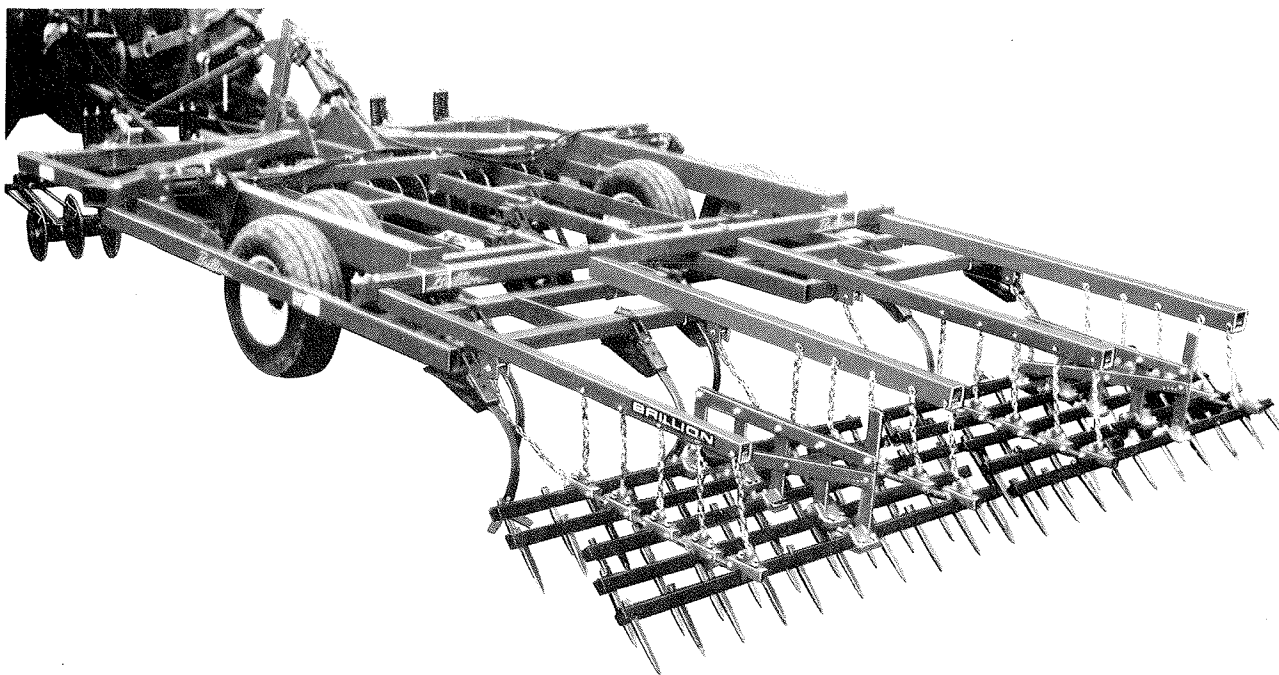

SOIL GROOMER



MODELS :

SGS-241	SGR-241
SGS-241-1	SGR-241-1
SGS-271	SGR-271
SGS-271-1	SGR-271-1
SGS-301	SGR-301
SGS-301-1	SGR-301-1

BRILLION IRON WORKS, INC.
BRILLION, WISCONSIN 54110

C O N T E N T S

	Page
Introduction - - - - -	3
Location Reference - - - - -	3
Parts Ordering - - - - -	3
Safety Suggestions - - - - -	4
Operating Instructions - - - - -	5
Tractor Preparation - - - - -	5
Soil Groomer Preparation - - - - -	5
Bleeding Depth Control Cylinder - - - - -	5
Bleeding Wing Lift Cylinders - - - - -	6
Side to Side Leveling - - - - -	6
Depth Adjustment - - - - -	6
Wing Leveling (24' Machine Only) - - - - -	7
Wing Down Float Adjustment (24' Machine Only) - - - - -	7
Transport - - - - -	7
Rephasing - - - - -	8
Hitch Leveling - - - - -	8
Working Speed - - - - -	8
Turning - - - - -	8
Disk Depth Adjustment - - - - -	8
Disk Pressure Adjustment - - - - -	8
Disk Scraper Pressure Adjustment - - - - -	9
Spike Tooth Harrow Adjustment - - - - -	10
Chemical Incorporation - - - - -	10
Roller Harrow Adjustment - - - - -	11
Maintenance - - - - -	12
Fasteners - - - - -	12
Center Tires - - - - -	12
Wing Tires - - - - -	12
Lubrication - - - - -	12
Replacing Points - - - - -	12
Disk Gang Maintenance - - - - -	12
Shipping Bundles - - - - -	13
Setting Up Instructions - - - - -	15
Wing Installation (24' Machine Only) - - - - -	22
Wing Installation (27' & 30' Machines Only) - - - - -	26
Spike Tooth Harrow Installation - - - - -	30
Roller Harrow Installation - - - - -	32
Hydraulic Hose Installation - - - - -	33
Setup Locations With Spike Tooth Harrows - - - - -	38
Setup Locations With Roller Harrows - - - - -	44
Specifications - - - - -	50

INTRODUCTION

Your Brillion Soil Groomer is built with the best materials and workmanship available. It has been designed to give years of trouble-free operation. Proper care and operation will insure that you receive the service and long life built into this machine.

Study this manual carefully before attempting to assemble or operate the machine. A special section, "Setting Up Instructions", is included.



This safety alert symbol is used to call your attention to instructions concerning personal safety. Federal law requires you to explain the safety and operating instructions furnished with this machine to each employee before they are allowed to operate the machine. These must be repeated to the employee at the beginning of each season. Be sure to observe and follow the instructions for the safety of anyone operating or near the machine.

Location Reference

Right hand, left hand, forward and rear refer to operator's right, left, front and rear when he faces the same direction as the machine will travel in field.

Parts Ordering

When ordering parts for this machine, include the complete model number and serial number. Refer to the name plate on the right rear hinge of the center section. Please record these numbers upon taking delivery of the unit.

Soil Groomer Model No. _____

Serial Number _____

Date Purchased _____

Be sure to read the warranty card which is shipped with the machine. Return the proper portion of the card for recording at the factory.



SAFETY SUGGESTIONS

Investigation has shown that nearly 1/3 of all farm accidents are caused by careless use of machinery. You can do your part in improving safety by observing the following suggestions. Insist that all people working with you or for you abide by them.

1. Do not stand between the tractor and implement when attaching or detaching implement unless both are not moving.
2. Do not fold or unfold the wings or operate the machine without first bleeding air from the hydraulic systems.
3. Do not allow anyone near the machine when folding or unfolding the wings.
4. Do not make adjustments or lubricate machine while it is in motion.
5. Do not allow anyone to ride on tractor or machine.
6. Relieve pressure in hydraulic lines before uncoupling hydraulic hoses from tractor. On most tractors this can be done by operating valves after engine is stopped.
7. Always use two transport locks for center frame wheel cylinders and the lock on front center master cylinder when transporting machine.
8. Lower machine to ground when not in use.
9. Block machine so it will not roll when unhitched from tractor.
10. Do not transport at speeds over 20 mph.
11. Avoid sudden stops or turns when transporting because weight of machine may cause operator to lose control of tractor. Use a tractor heavier than machine. Do not allow tractor drawbar to swing when transporting.
12. Use caution when towing behind articulated steering tractors; fast or sharp turns may cause the machine to whip sideways.
13. Securely block machine when working on or under it to prevent injury in case of hydraulic failure or inadvertent lowering by another person.

OPERATING INSTRUCTIONS

Tractor Preparation



Lock tractor drawbar in center position. Do not allow the drawbar to swing, especially during transport.

Soil Groomer Preparation

Hydraulic oil capacity of the 24' Soil Groomer is approximately 4.3 gallons. Hydraulic oil capacity of 27' and 30' Soil Groomers are approximately 7.5 gallons.

Clean hose fittings before connecting to tractor. It is also necessary during initial operation to watch tractor oil level closely to avoid damage.

Depth control and machine leveling is accomplished by a system of three cylinders in series. Be sure they are connected so that flow is from largest bore cylinder to the smallest in decreasing size. Also the rod end of the first cylinder must be connected to the anchor end of the second, etc. See hydraulic diagrams on pages 34 and 35.

Bleeding Depth Control Cylinders

For machine to operate at uniform depth, all air must be removed from series circuit. The following procedure is suggested.

1. Remove the two "U" shaped transport lock members over wheel arm cylinder rods. Slide striker plate against cylinder rod yoke on master cylinder on front center of machine.
2. Activate the hydraulic system until all rods are fully extended.
3. Cycle the cylinders from fully extended to fully retracted at least two times, pausing at full extension about 30 seconds.
4. Fully extend cylinders one more time and allow oil to flow through system about one minute by holding tractor valve open.
5. Depth control circuit should not be opened after this. If parts are removed and air enters system, circuit must be bled again.

If after this has been completed and the smallest hydraulic cylinder has a different extended pin center distance than the other cylinders, it will be necessary to repeat the above procedure with the rod end pins removed and the cylinders supported in a near vertical position.

Bleeding Wing Lift Cylinders

Raise the wings partially, and then lower them again. It is important to do this 7 or 8 times before the wings are raised 90°. The wings depend upon the passage of oil through a flow restrictor to keep them from free-falling. If the cylinders are not full of oil, the wings may drop and damage the machine.



The two wings are not tied together, and one may raise before the other. Both wings should raise before either goes over 90°.

If it becomes necessary to drain the oil from one or more cylinders, it is important to bleed the air out of the system before operating.

Side To Side Leveling

Consistent cultivating depth is maintained along the entire machine by operating properly bled cylinders. If additional leveling is necessary, lengthen the cylinder on the machine with the deeper working depth. NOTE: A setscrew in the rod yoke will have to be loosened, then tightened after adjustment is made.

Depth Adjustment

The master cylinder (located on the front center of machine) controls operating depth of the entire machine. When the desired depth is obtained, slide the striker plate along the cylinder rod, depressing the plunger on top of the cylinder. Fix the striker plate in this position by tightening the tee handle. The depth gage strip attached to the cylinder yoke is merely a reference tool to enable you to reset depth stop to a predetermined setting.

Wing Leveling (24' Machine Only)

The wing side to side leveling may be accomplished by extending or retracting the ratchet jack attached to the wheel.

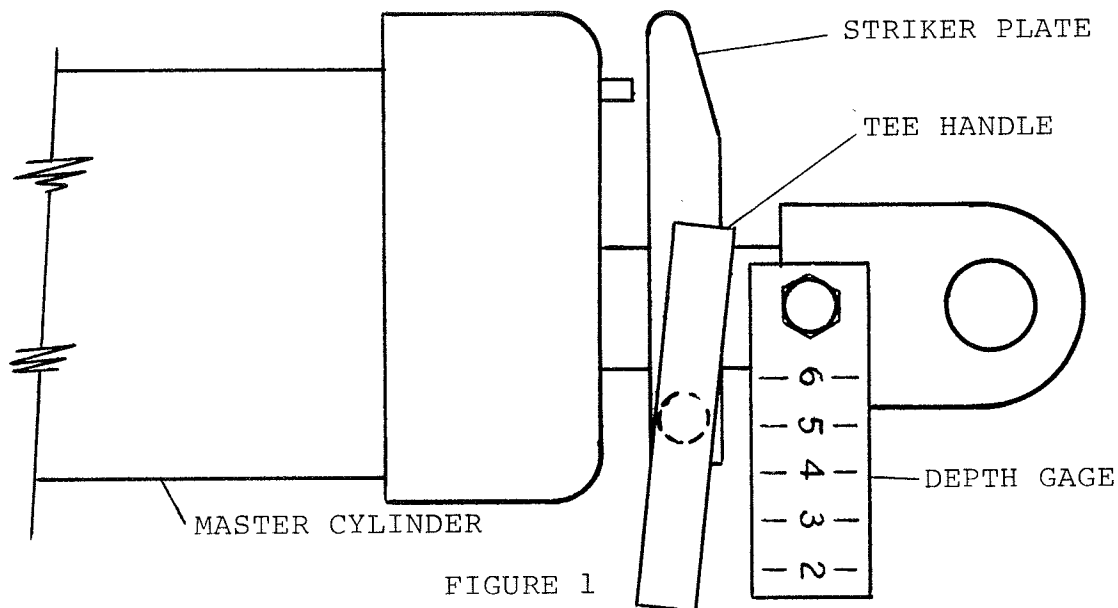

Wing Leveling on Hydraulic Gage Wheel Models

The wing side to side leveling is done by adjusting the nuts on the eye bolt of the cylinder anchor. If additional adjustment is needed the clevis on the cylinders may be adjusted.

Wing Down Float Adjustment (24' machine only)

The stop blocks on frame hinges can be rotated to change down float. Adjust to hold the outside up as far as possible. This will lessen soil piling and stress on wing frame. If one of the four settings does not provide the exact setting, remove material from a long side of blocks to obtain float desired. The stop blocks used with manual controlled wing gage wheels for down float adjustment should not be used with hydraulic gage wheels.

Transport

To prepare a machine for transport, raise it fully out of ground. Then place two "U" shaped transport lock members over wheel arm cylinder rods. Secure with 1/2" x 3-1/4" clevis pins and hair pin cotters. The "U" shaped members can be stored on the wheel lift arms. The "U" shaped transport lock members must not be exchanged between cylinders.

The front center master cylinder must also be locked for transport. Note depth setting using depth gage strip before moving striker plate. Loosen the tee handle on the master cylinder striker plate and slide this striker plate down against depth stop plunger; then retighten.



Maximum road speed is 20 MPH under good conditions. Do not tow the machine at a speed where the operator loses control of his vehicle.

It is the responsibility of the owner/operator to comply with all applicable laws regarding slow moving vehicle signs, warning lights and reflectors.

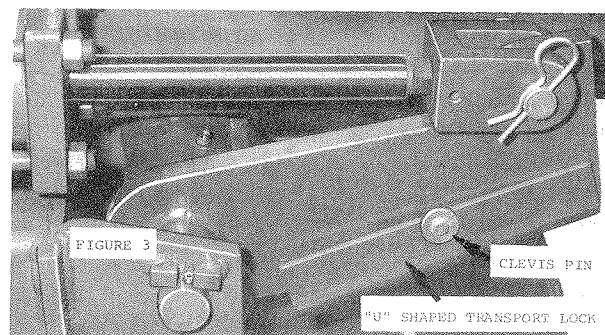
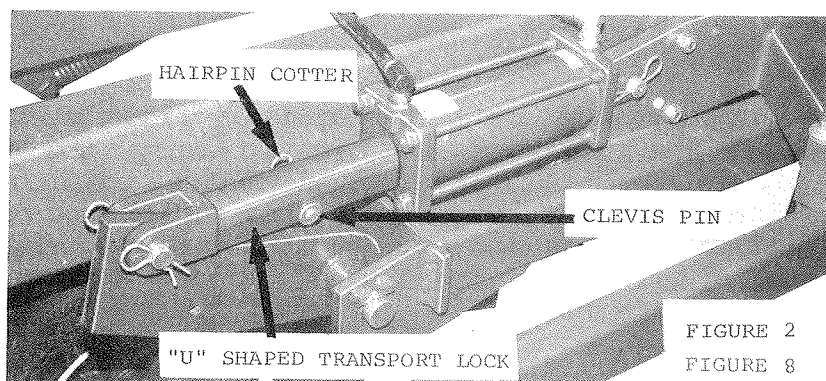

Rephasing

Occasionally, machine should be raised completely out of the ground an lift lever on tractor held for a few seconds. This will rephase depth control cylinders and insure uniform working depth.

Hitch Leveling

The machine may be leveled (front to rear) in transport position after the depth control cylinders are synchronized by bleeding. Make sure the tractor and Soil Groomer are on a level surface and extend or retract the drawbar brace rod assembly until the machine is parallel (front to rear) to the ground surface. Only minor adjustments will be necessary in field.

Working Speed

Best results are obtained by operating at a speed of 5 to 8 MPH, especially if roller harrows are used. Somewhat higher rates are also acceptable, but in no event should speed exceed the point at which the operator can safely control tractor and implement.

Turning

Because of the sideways anchoring affect of the disk gangs the machine should always be raised when turning at the end of the field. This will relieve stress on the disk gangs and machine frame as well as eliminate large soil piles resulting from forcing the disks sideways.

Disk Depth Adjustment

This adjustment is provided to allow the disk cutting depth to be set independent of the cultivator shanks. This provides for more cutting and leveling in rough, trashy conditions and also allows the disks to be raised in loose soil conditions where aggressive disk tillage is not desired (shallow incorporation) and where excess sideways soil movement causes disk gang ridging.

The disks may be adjusted to cut two inches below to three inches above the cultivator sweeps. The procedure involves loosening the horizontal carriage bolts and advancing the double nutted vertical adjusting bolt in the appropriate direction. Both are located under the springs on the disk gangs. When adjustment is completed tighten the double jam nuts and nuts on carriage bolts.

Disk Pressure Adjustment

The disk gangs are spring loaded to provide protection from impacts but they must be adjusted correctly to provide maximum protection without reducing working depth. The lock nuts on top of the spring pairs should be adjusted down for increased pressure and constant working depth, if the disk gangs are constantly bobbing up and down. Conversely, the pressure should be reduced by advancing the nuts up, if the gangs never or seldom retract. Less spring pressure reduces possibility of disk damage. Adjust both nuts per spring set the same amount.

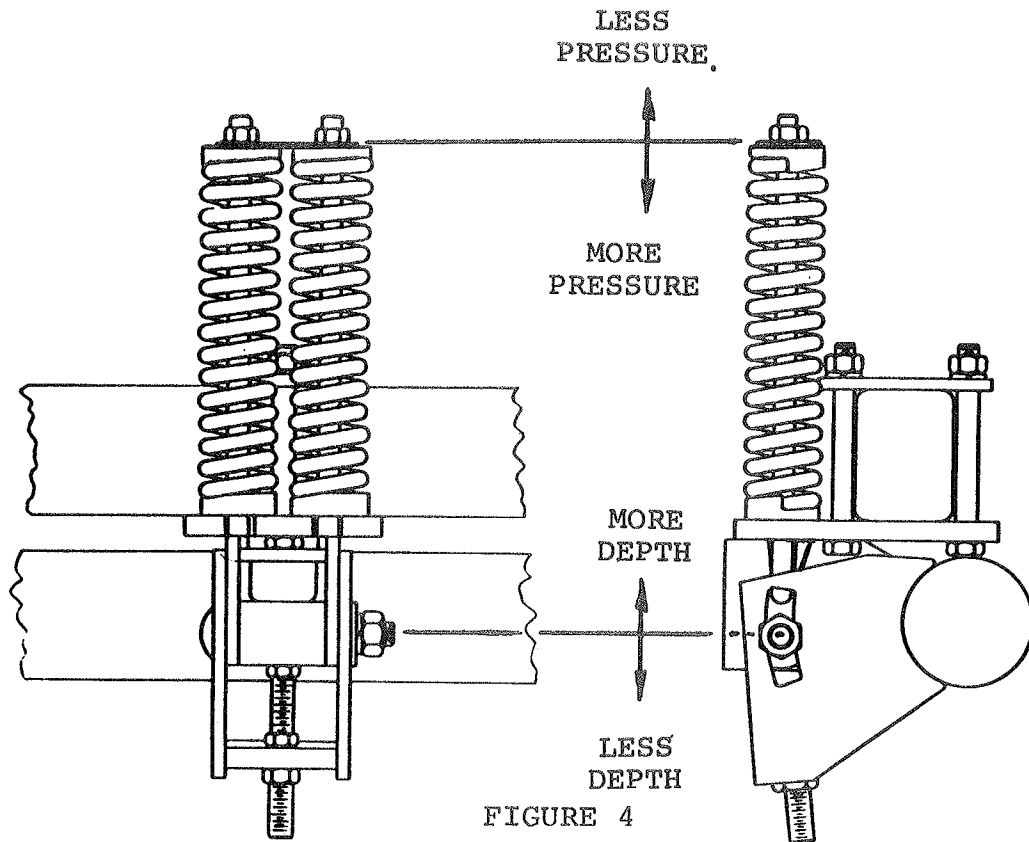

FIGURE 4

Disk Scraper Pressure Adjustment

Do not tighten scrapers tight against disk blades, this will cause rapid wear.

To properly adjust scrapers, loosen both the 3/8" bolt in the arm and the set screw in the scraper. Swing the scraper against the disk blade and tighten the set screw, then swing the scraper 1/16" to 1/8" away from the disk blade and tighten the 3/8" bolt to lock in place.

All the scrapers can be adjusted by loosening the two bolts that hold the scraper bar to the disk frame and sliding the bar in the direction needed and then retightening the bolts. Take care not to slide the bolts out of the slots.

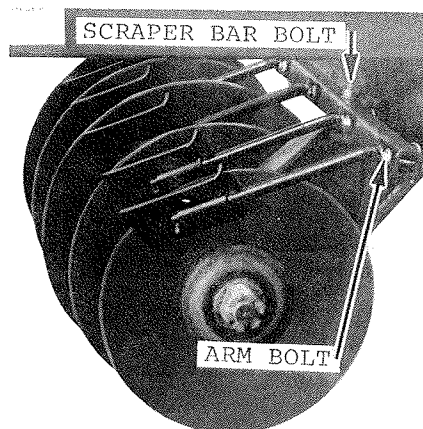

FIGURE 5

Spike Tooth Harrow Adjustment

If spike tooth harrow sections build up with soil or plant residue one or more of the following can be done: 1) flatten spike angle, 2) shorten draft chains, 3) shorten the support chains.

Adjustments are easiest to make with spike tooth harrow sections not in contact with ground. The most soil mixing will occur with steeper spike angle section not being held up by support chains.

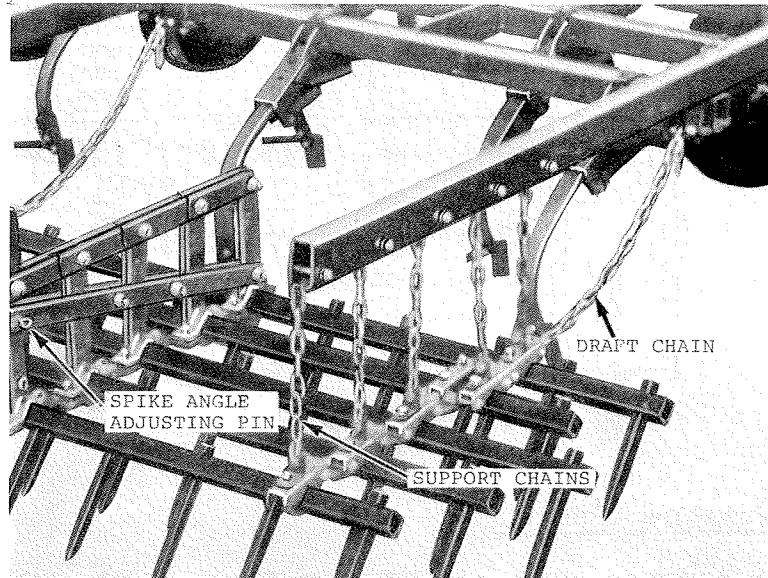

FIGURE 6

Chemical Incorporation

The primary requirement for successful incorporation is following the chemical manufacturer's instructions. However, the following suggestions are generally recognized, and should be observed unless specific instructions say otherwise:

1. Many herbicides, especially shallow incorporated types should be sprayed on level ground. This can be accomplished by mounting spray nozzles in the 42" spray zone provided behind the disk gangs on the Soil Groomer. In extreme conditions, it may be necessary to install an optional spray curtain to protect the nozzles from soil thrown by the disks.
2. Two passes, with the second at an angle to the first, usually give the best mixing. Disk gangs are best set shallow if a second pass is used to reduce oneway soil movement and resulting hot and cold spots.
3. Second pass should not be deeper than the first or untreated soil will be brought to the top.
4. If only one pass is made, shovels or sweeps will do a better job than points.
5. Machine should be level; rear tines must not be set deeper than those at front.
6. Good mixing can not be obtained in wet soil.

7. Relatively high speeds (6 - 8 mph) provide the best mixing.

Spray nozzles may be mounted on the Soil Groomer, but tanks should not, since the machine has not been designed to handle the extra weight.

Roller Harrow Adjustments

Three types of adjustments are provided: (1) Upward-downward of entire assemblies, (2) angular (changes height of front harrow reel with respect to rear reel), and (3) spring tension. While exact settings will need to be determined by trial, the following is intended as a general guide:

1. Entire assemblies can be held out of the ground. This may be desirable if the machine is being used to work a wet field at a shallow depth for drying.

By inserting depth control pins as high as possible with harrows still penetrating the ground, the harrows can be lifted out of the ground without raising the machine fully when turning. This will reduce side loading and resultant stress on harrows and mounting brackets.

Disconnecting spring handles to release spring tension or lowering machine with a block under each rolling harrow reel can make this adjustment easier.

2. Angular adjustment for shallow working depths can have both reels at the same height. At greater depths with more loose soil available, the front reel should be slightly higher than the rear. This will prevent "blocking" of the front reel.
3. Spring tension prevents excessive bouncing. Extreme tension, beyond that which can be comfortably obtained with one hand, is usually not necessary.

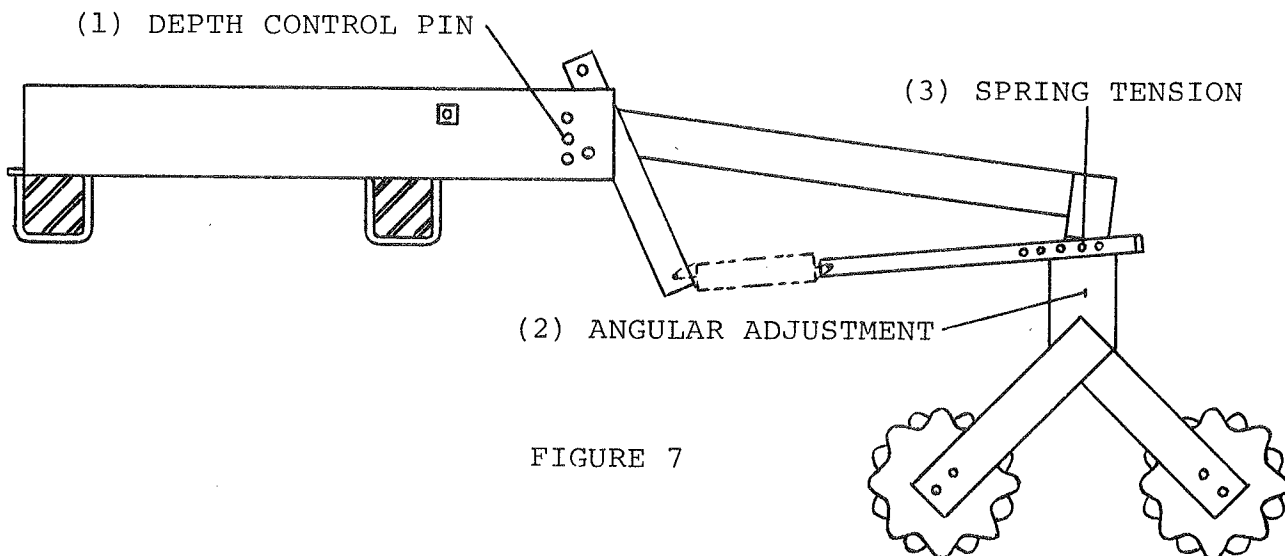

FIGURE 7

MAINTENANCE

Fasteners

After a few hours of use check entire machine and tighten any loose nuts or bolts. Daily or periodic checks should be made thereafter.

Center Tires

Recommended size of four tires on 24' machine: 9.5L x 15 8 ply inflated to 40 psi. 11L x 15 8 ply tires inflated to 36 psi may be used in place of 9.5L x 15 tires. Recommended size of four tires on 27' and 30' machines are 11L x 15 10 ply inflated to 42 psi.

Wing Tires

Recommended size of two tires on 24' machine: 6.70 or 7.60 x 15 6 ply inflated to 24 psi. Recommended size of two tires on 27' and 30' machines: 9.5L x 15 6 ply inflated to 32 psi.

Lubrication

Grease zerks fittings daily. Locations are:

Disk rockshaft bearings - - - - - 8 (2 zerks per bearing)
Wheel arm pivots - - - - - 2

The above items are not sealed and cannot be overgreased. Roller harrows should also be greased daily. The best time is after machine is done running, to prevent condensation in the bearings. Give each bearing about two "shots" or grease until seal just starts to lift.

Wheel bearings and walking beam pivots should be repacked annually.

When Soil Groomer is not used for some time, exposed cylinder rods should be cleaned and covered with a thick coat of grease. This will prevent corrosion which will damage seals.

Replacing Points or Sweeps

When points or sweeps are turned or replaced, all of them on the machine should be of the same length to insure uniform operating depth and proper trailing of the Soil Groomer. It is normal for points or sweeps working in the tractor tracks to wear faster because of soil compaction. Turn or replace points or sweeps before the end of the tooth shank begins to wear.

Disk Gang Maintenance

After a few hours of use check tightness of gang nut. Tighten to 1,100 foot pounds torque, then loosen slightly to allow reinstalling locking cotter pin. Daily or periodic checks should be made there after.

CAUTION: Loose blades will cut disk gang axle, damage bearing, spacer spools and will cause disk gang axles to bend.

SHIPPING BUNDLES

NOTE: REFER TO REPAIR PARTS CATALOG FOR IDENTIFICATION OF PARTS AND FOR APPROXIMATE RELATIONSHIP OF PARTS IN ASSEMBLY.

SHIPPING BUNDLE CHECK LIST: Your Brillion Soil Groomer is shipped to you in separate assemblies. These shipping bundles and assemblies are:

BUNDLE NAME	Spike Tooth Harrow Models							
	SGS-24	SGS24-1	SGSH-24	SGSH24-1	SGS-27	SGS27-1	SGS-30	SGS30-1
	Shank Spacing Working Width	9" 24'	6" 24'	9" 24'	6" 24'	9" 27'	6" 27'	9" 30'
	QUANTITY PER MACHINE							
Center frame	1	1	1	1	1	1	1	1
Front Lift Arm	1	1	1	1	1	1	1	1
Brace Rod Assembly	1	1	1	1	-	-	-	-
Brace Assembly	-	-	-	-	1	1	1	1
Drawbar Assembly	1	1	1	1	1	1	1	1
Drawbar Jack	1	1	1	1	1	1	1	1
Disk Axle Assembly L.H.	2	2	2	2	2	2	2	2
Disk Axle Assembly R.H.	2	2	2	2	2	2	2	2
Walking Beam Assembly L.H.	1	1	1	1	1	1	1	1
Walking Beam Assembly R.H.	1	1	1	1	1	1	1	1
Rear Super Tube	1	1	1	1	1	1	1	1
Tube Weldment L.H.	1	1	1	1	1	1	1	1
Tube Weldment R.H.	1	1	1	1	1	1	1	1
Master Hydraulic Cyl. 5 x 8	1	1	1	1	1	1	1	1
Hydraulic Cyl. 4-3/4 x 8	1	1	1	1	1	1	1	1
Hydraulic Cylinder 4 1/2 x 8	1	1	1	1	1	1	1	1
Hydraulic Cylinder 4 x 8	-	-	1	1	1	1	1	1
Hydraulic Cyl. 3-3/4 x 8	-	-	1	1	1	1	1	1
Hydraulic Cylinder 3 1/2 x 16	2	2	2	2	4	4	4	4
Tooth Frame	4	4	4	4	4	4	4	4
Wheel	6	6	6	6	6	6	6	6
Cultivator Shank Assembly	33	49	33	49	37	55	41	61
Tooth Extension 4-1/2	6	12	6	12	8	16	6	16
Tooth Extension 8-1/2	6	4	6	4	6	4	8	4
Tooth Extension 12	-	2	-	2	2	4	2	6
Tooth Extension 17-1/2	10	10	10	10	2	2	4	4
Drag Support	8	8	8	8	8	8	8	8
Drag Bar Assembly 70"	2	2	2	2	-	-	-	-
Drag Bar Assembly 90"	2	2	2	2	4	4	2	2
Drag Bar Assembly 100"	-	-	-	-	-	-	2	2
Box Assembly	16	17	17	18	19	21	19	21
Middle Tube Extension 20"	1	1	1	1	1	1	1	1
Front Wing Frame	2	2	2	2	2	2	2	2
Wing Hinge Tube	2	2	2	2	2	2	2	2
Gauge Wheel Arm	2	2	2	2	2	2	2	2
Ratchet Jack Assembly	2	2	-	-	1	1	1	1
Wing Stand Assembly	2	2	2	2	4	4	4	4
Hinge Weldment	4	4	4	4	-	-	-	-
Lift Hinge Assembly	-	-	-	-	2	2	2	2
Anchor Assembly	2	2	2	2	-	-	-	-
Long Wing Tube	-	-	-	-	2	2	2	2
Pin Assembly	-	-	-	-	2	2	2	2
Lug Assembly	-	-	-	-	2	2	2	2

Points or sweeps are ordered separately.

Spray Shield (for mounting behind discs) is optional.

SHIPPING BUNDLES

NOTE: REFER TO REPAIR PARTS CATALOG FOR IDENTIFICATION OF PARTS AND FOR APPROXIMATE RELATIONSHIP OF PARTS IN ASSEMBLY.



SHIPPING BUNDLE CHECK LIST: Your Brillion Soil Groomer is shipped to you in separate assemblies. These shipping bundles and assemblies are:

Two Gang Roller Harrow Models

BUNDLE NAME	SGR-24	SGR24-1	SGRH-24	SGRH24-1	SGR-27	SGR27-1	SGR-30	SGR30-1
	9" Shank Spacing 24' Working Width	6" Shank Spacing 24' Working Width	9" Shank Spacing 24' Working Width	6" Shank Spacing 24' Working Width	9" Shank Spacing 27' Working Width	6" Shank Spacing 27' Working Width	9" Shank Spacing 30' Working Width	6" Shank Spacing 30' Working Width
	QUANTITY PER MACHINE							
Center Frame	1	1	1	1	1	1	1	1
Front Lift Arm	1	1	1	1	1	1	1	1
Brace Rod Assembly	1	1	1	1	-	-	-	-
Brace Assembly	-	-	-	-	1	1	1	1
Drawbar Assembly	1	1	1	1	1	1	1	1
Drawbar Jack	1	1	1	1	1	1	1	1
Disc Axle Assembly L.H.	2	2	2	2	2	2	2	2
Disc Axle Assembly R.H.	2	2	2	2	2	2	2	2
Walking Beam Assembly L.H.	1	1	1	1	1	1	1	1
Walking Beam Assembly R.H.	1	1	1	1	1	1	1	1
Rear Super Tube	1	1	1	1	1	1	1	1
Tube Weldment L.H.	1	1	1	1	1	1	1	1
Tube Weldment R.H.	1	1	1	1	1	1	1	1
Master Hydraulic Cyl. 5 x 8	1	1	1	1	1	1	1	1
Hydraulic Cyl. 4-3/4 x 8	1	1	1	1	1	1	1	1
Hydraulic Cyl. 4-1/2 x 8	1	1	1	1	1	1	1	1
Hydraulic Cylinder 4 x 8	-	-	1	1	1	1	1	1
Hydraulic Cyl. 3-3/4 x 8	-	-	1	1	1	1	1	1
Hydraulic Cyl. 3-1/2 x 16	2	2	2	2	4	4	4	4
Tooth Frame	4	4	4	4	4	4	4	4
Wheel	6	6	6	6	6	6	6	6
Cultivator Shank Assm.	33	49	33	49	37	55	41	61
Tooth Extension 4-1/2	4	12	4	12	2	12	2	14
Tooth Extension 6	2	2	2	2	2	2	2	2
Tooth Extension 8-1/2	5	3	5	3	5	3	9	5
Tooth Extension 12	-	2	-	2	2	4	2	6
Tooth Extension 17-1/2	10	10	10	10	2	2	4	4
Basket Bracket	9	9	9	9	9	9	11	11
Roller Harrow Extension	3	7	3	7	5	7	7	9
Offset Extension Assembly	6	2	6	2	4	2	4	2
Long Harrow Section 40"	6	6	6	6	8	8	7	7
Short Harrow Section 24"	3	3	3	3	1	1	4	4
Middle Tube Extension 20"	3	3	3	3	3	3	3	3
Box Assembly	17	18	18	19	19	20	20	22
Front Wing Frame	2	2	2	2	2	2	2	2
Wing Hinge Tube	2	2	2	2	2	2	2	2
Gauge Wheel Arm	2	2	2	2	2	2	2	2
Ratchet Jack Assembly	2	2	-	-	1	1	1	1
Wing Stand Assembly	2	2	2	2	4	4	4	4
Hinge Weldment	4	4	4	4	-	-	-	-
Lift Hinge Assembly	-	-	-	-	2	2	2	2
Anchor Assembly	2	2	2	2	-	-	-	-
Long Wing Tube	-	-	-	-	2	2	2	2
Pin Assembly	-	-	-	-	2	2	2	2
Lug Assembly	-	-	-	-	2	2	2	2

Points or sweeps are ordered separately

Spray Shield (for mounting behind discs) is optional

BOLTS AND NUTS		
Recommended Torque in Foot-Pounds Coarse and Fine Threads		
		
Bolt Diameter	Grade 2	Grade 5
1/4	5	8
5/16	11	17
3/8	20	30
7/16	30	50
1/2	50	75
9/16	65	110
5/8	90	150
3/4	160	260
7/8	140	400
1	220	580

Tighten all bolts to the torques specified in the chart above. It is important that bolts be kept tight at all times. Loose bolts can cause breakage of parts. Check the tightness of bolts periodically and keep them tightened to the torques specified above.

NOTE: Use boxes 5J-871, 6J-682 and 6J-324 (24' only) or 6J-325 (27' and 30' only) for initial set up steps.

1. Support center frame on four stands at least 30" high. Be sure supports are stable and of adequate strength to carry machine weight. Install one shank on each side of center frame near lug for base end of wheel arm hydraulic cylinder. (These are the shanks shown at 12½" or 13" on pages 38-49).
2. Attach right and left walking beam assemblies on machine with 8 bolt wheels on hubs. Use greased 1-1/2" x 13" pins with 5/16" x 2" roll pin and 3/16" x 2" roll pins between small blocks on center frame. Position the slit in large roll pin against a small block on center frame. Place small roll pin inside each large roll pin with the slit rotated 90°. The outside tire must be behind inside tire. Recommended size of four tires on 24' machines on 8 bolt wheels are 9.5L x 15 8 ply inflated to 40 psi. 11L x 15 8 ply tires inflated to 36 psi may be used in place of 9.5L x 15 tires. Recommended size of four tires on 27' and 30' machines on 8 bolt wheels are 11L x 15 10 ply inflated to 42 psi.

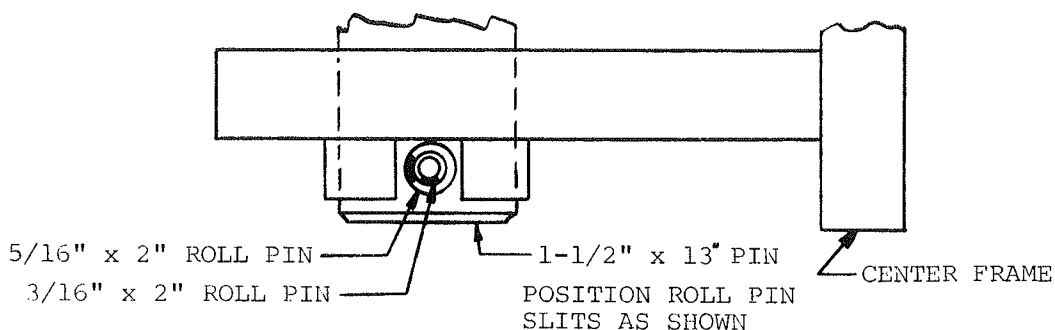

3. Adjust the five short hydraulic cylinders (three on 24' machines) to 20-1/4" retracted pin centers (if necessary). Be sure to tighten clevises of all hydraulic cylinders. For 24' machines only install 9J-487 (4-3/4" bore) slave cylinder on right side with ports up and install 9J-485 (4-1/2" bore) slave cylinder on left side with ports up. For 27' and 30' machines only install 9J-485 (4-1/2" bore) slave cylinder on right side with ports up and 9J-484 (4" bore) slave cylinder on left side with ports up.

4. With wheel arm hydraulic cylinder extended, place "U" shaped transport lock members over each wheel arm cylinder rod.

9J-487 (4-3/4" bore) uses 6J-650 (8-7/16" painted green).

9J-485 (4-1/2" bore) uses 6J-651 (8-7/16" painted green).

9J-484 (4" bore) uses 6J-649 (10" painted red).

Secure with 1/2" x 3-1/4" clevis pins and hair pin cotters.

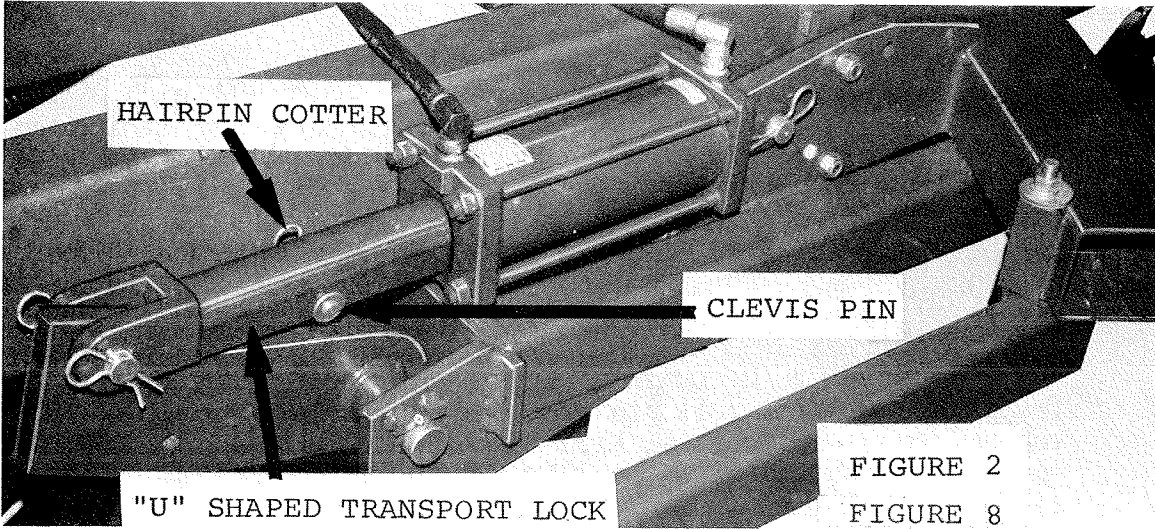

NOTE: Use boxes 7J962 and two of 6J697 next.

5. Position the left and right disk gang assemblies with all 18" blades under center frame, with frames forward, scraper bars on top with blades cupped inward. Lubricate the inner bearing of the castings with grease before assembly. Bearing halves will be placed around the ends of the rockshaft pipes, near the standards. The side grease zerks on top halves must be away from frame standard. Mount a bearing bracket over front of the center frame, near a standard and the middle of the frame. Fasten bracket to frame loosely with 5/8" x 6" bolt, nut and lockwasher. Position bearing halves around rockshaft and attach with 5/8" x 11" bolts and 5/8" x 6½" bolts, lockwashers and nut. Pivot frames up with blades resting on floor. Do not tighten these bolts at this time.

Next assemble outside bearings with 5/8" x 6" bolt and lockwasher, turned into tapped hole in plate on underside of center frame. Front of bearing is attached with 5/8" x 7" bolt, lockwasher and nut. All bolts can be tightened now.

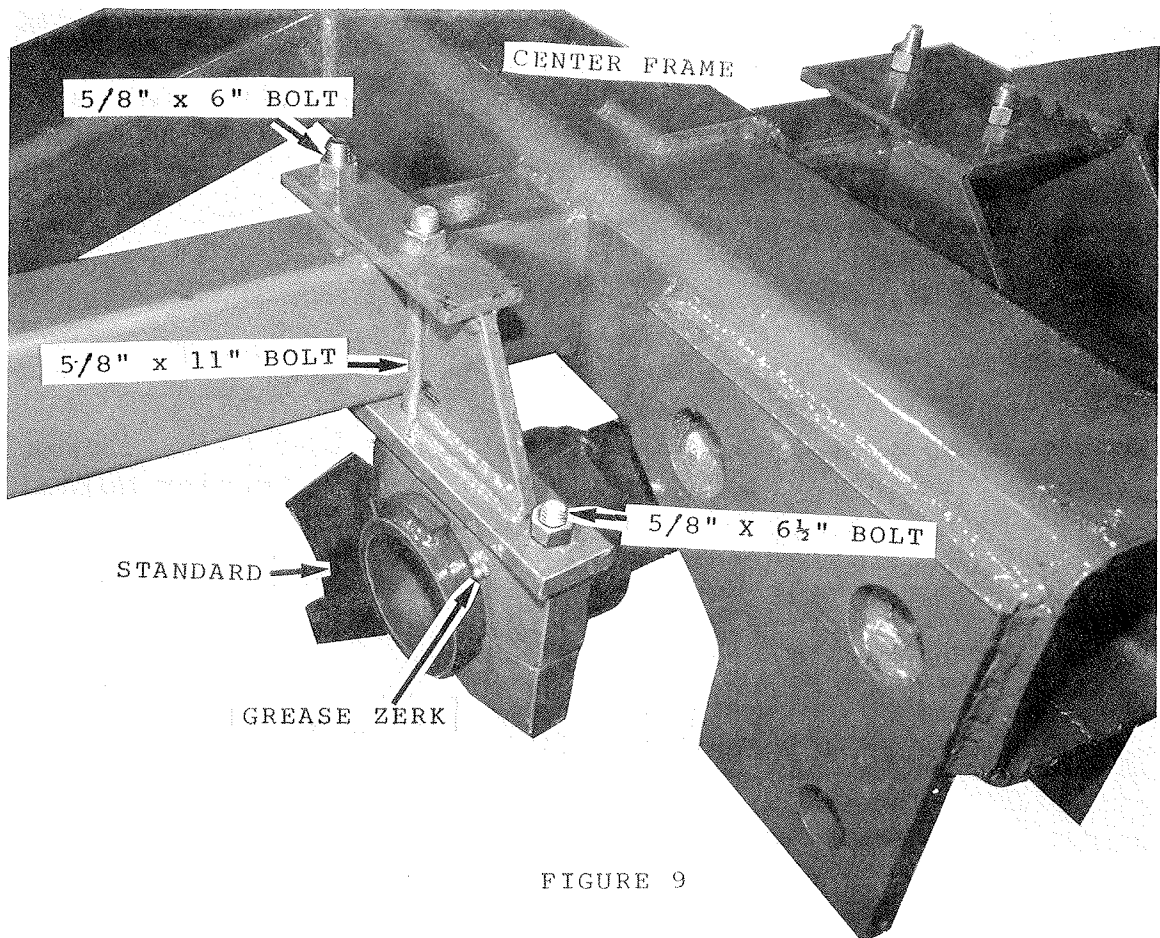

FIGURE 9

6. Run a 3/4" jam nut all the way onto each of the adjusting bolt weldments and insert threaded ends through cross plate between arm pairs on the rock shaft. Place cast iron U-bolt clips on the pin of coupler weldment. Slide long U-bolts through coupler weldments and rotate 90°. Place the 3 part assembly between arms of rock shaft with the bolt weldment between the plates of coupler weldment. Insert 3/4" x 5-1/2" carriage bolt through the assemblies. Place another 3/4" jam nut on bolt weldment. Lock the 2 jam nut pairs in the middle position for initial set up. Tighten the 3/4" lock nuts on the carriage bolts.
7. Install outside spring holders on center frame with 5/8" x 6" bolts, nuts and lockwashers with bolt head on bottom loosely. Position spring holders by placing long vertical U-bolts in center of slots then tighten bolts.

Install inside spring holders on center frame with 5/8" x 6" bolts, nuts, lockwashers and straps with rounded ends forward loosely. Position spring holders by placing long vertical U-bolts in center of slots then tighten bolts.

8. Install springs with a cap on both ends (having flat sides outward) on long U-bolts resting on spring holders. Place a 3/16" x 2" x 4-1/2" strap on U-bolts with lock nut tightened initially to expose 1" thread. Note: Place a small spring inside each large spring.

For 24' machines only place small springs inside large springs on center section and wings. For 27' machines only place small springs inside large spring on center section only. No small springs are provided for wings. For 30' machines only place small springs inside large spring on center section and wings.

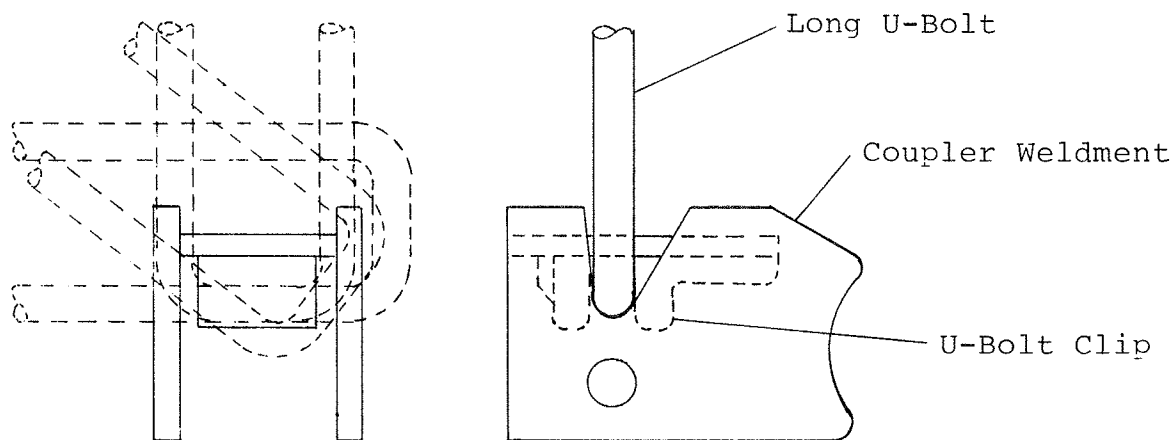

U-BOLT AND COUPLER ASSEMBLY

FIGURE 10

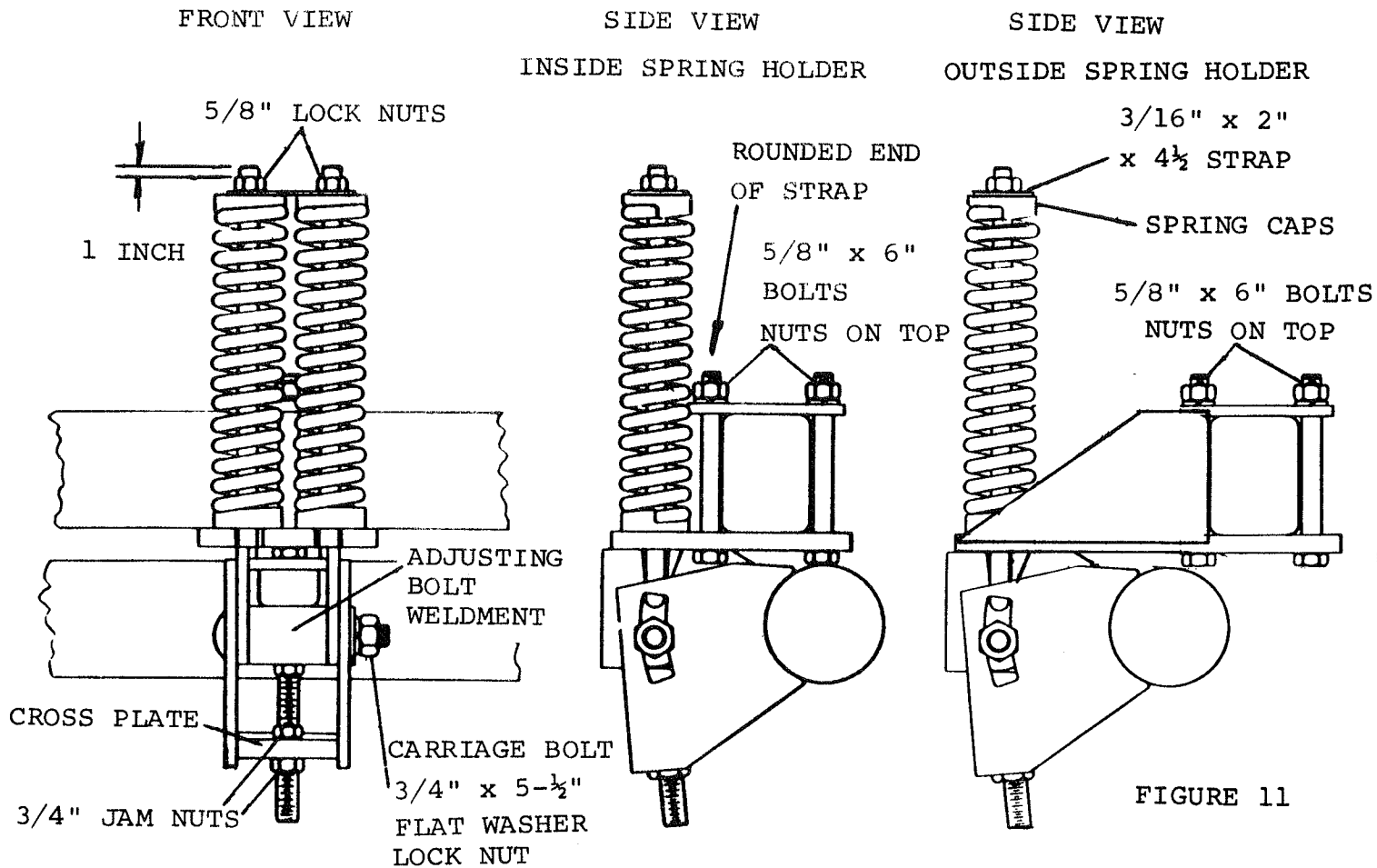

- Assemble the tee handle on the striker plate adjusting bolt. This provides a quick and convenient means of depth stop adjustment. Assemble the depth gage to the cylinder yoke using a 3/8" x 1/2" bolt, turned into the set screw hole. Do not remove setscrew. This depth gage is merely a reference tool to enable you to reset depth stop to a predetermined setting.

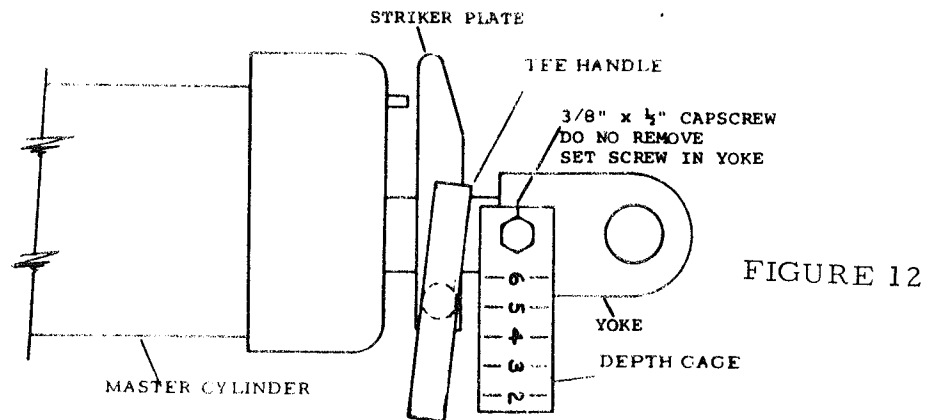

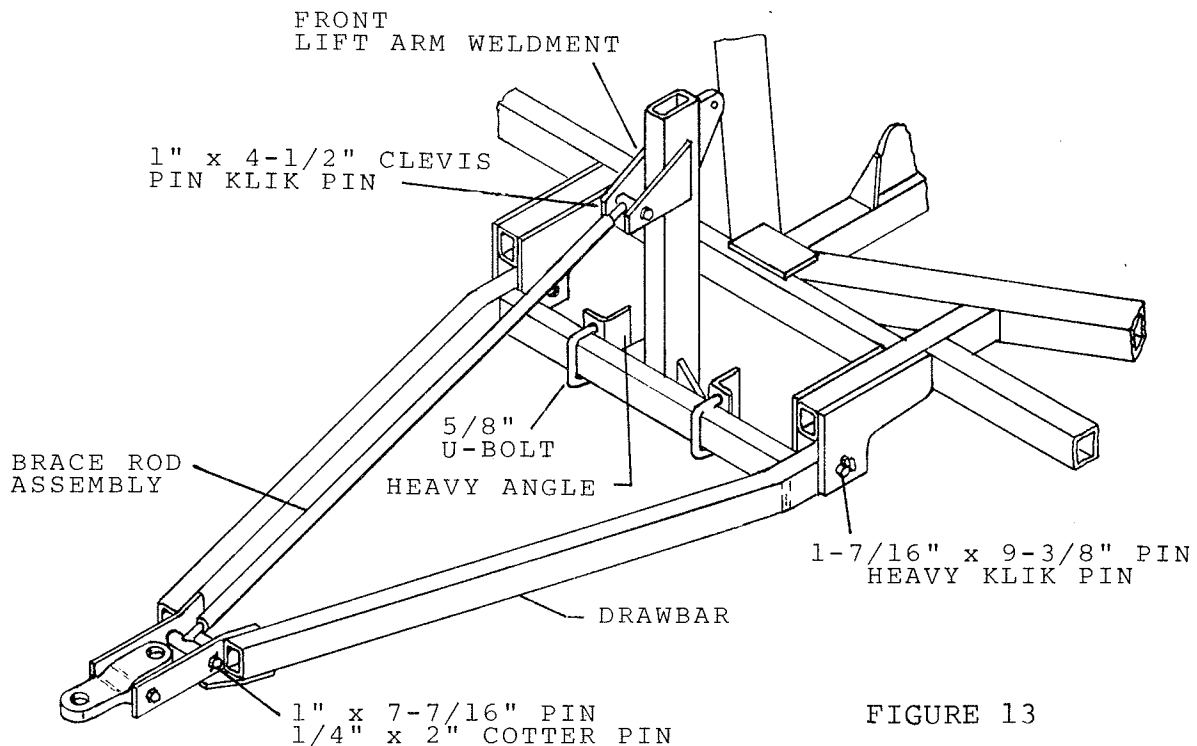
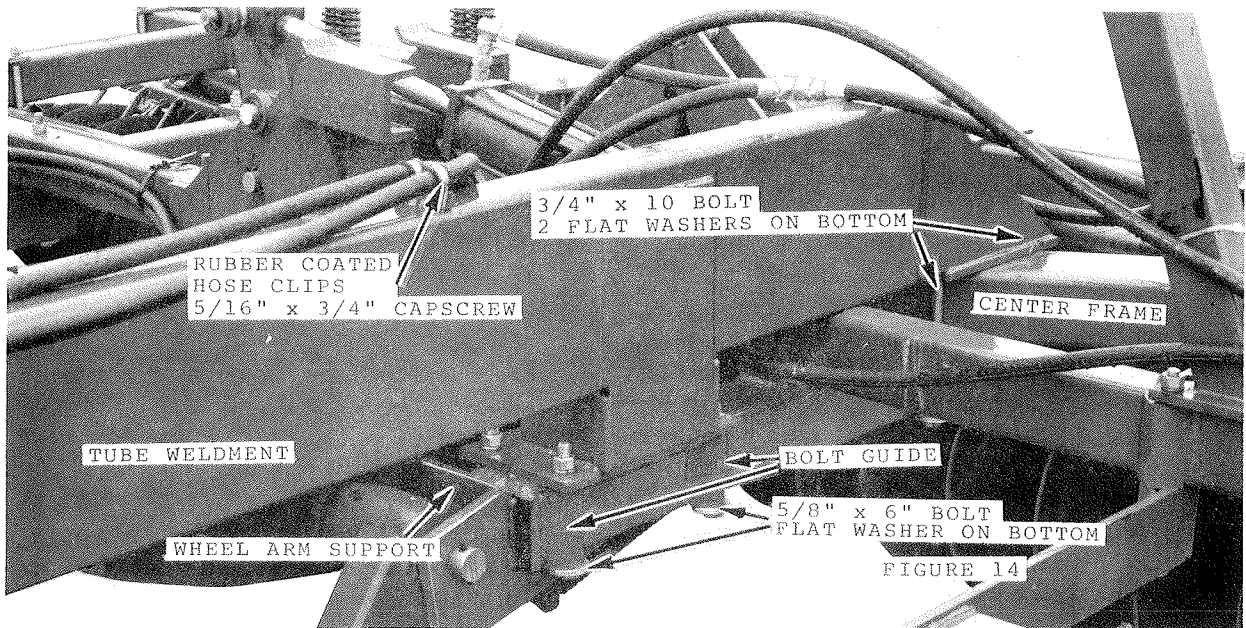

FIGURE 13

10. Install drawbar to center frame with 1-7/16" x 9-3/8" pins and klik pins with roll pins between small blocks on center frame.
11. Slide heavy angles over lift arm weldment shaft ends. Attach the angles to the rear center of drawbar stiffener tube with two 5/8" x 3-1/2" deep U-bolts, nut and lockwashers.
12. Attach base end of cylinder with ports up to center frame. Attach yoke end to lift arm weldment.
13. Install the drawbar brace rod assembly. Attach to the lift arm weldment with 1" x 4-1/2" clevis pin and klik pin. Attach to the front with the 1" x 7-7/16" pin in drawbar assembly. (The brace rod adjusts to locate the hitch clevis at the correct height for tractor drawbar and to level the machine.) Adjusting can be accomplished by turning the brace rod by its handle. On 27 and 30 foot machines a telescoping brace and a ratchet jack are used on the drawbar. The same attaching pins are used. Install the brace with the lugs on the bottom side and attach the ratchet jack with the pins furnished. Install the drawbar jack to the jack mounting tube. The mounting tube on the inside of the drawbar is intended for storage of jack when using machine; to avoid possible contact with tractor tire.

Install two hose holders to drawbar with 5/8" x 2" capscrew, flat washer, lockwasher and nut. One hose holder will be in hose box assembly.

14. Do not tighten the hardware in Steps 14, 15 and 16 until all associated parts are in place. Attach left and right tube weldments to center frame. Position the tube weldments inside wing folding cylinder anchors. Use four 3/4" x 10" bolts, eight flat washers (on bottom), four lockwashers and four nuts to attach the front. Use eight 5/8 x 6 bolts (through bolt guides), eight heavy washers, eight lockwashers and eight nuts to attach tube weldments to wheel arm supports.



15. Attach 4" x 4" rear super tube under rear of tube weldments centered with bolt guides forward with 3/4" x 6" bolts, lockwashers and nuts. The angles with bolt holes in must be on top.
16. Attach two identical large tooth frames under center section with hardware as shown below. Slide the tube weldments to obtain a distance of 32-3/8 inches between outside edge to tube weldments and outside edge of plates on 4" x 4" rear super tubes. All the hardware in Steps 14, 15 and 16 can now be tightened.

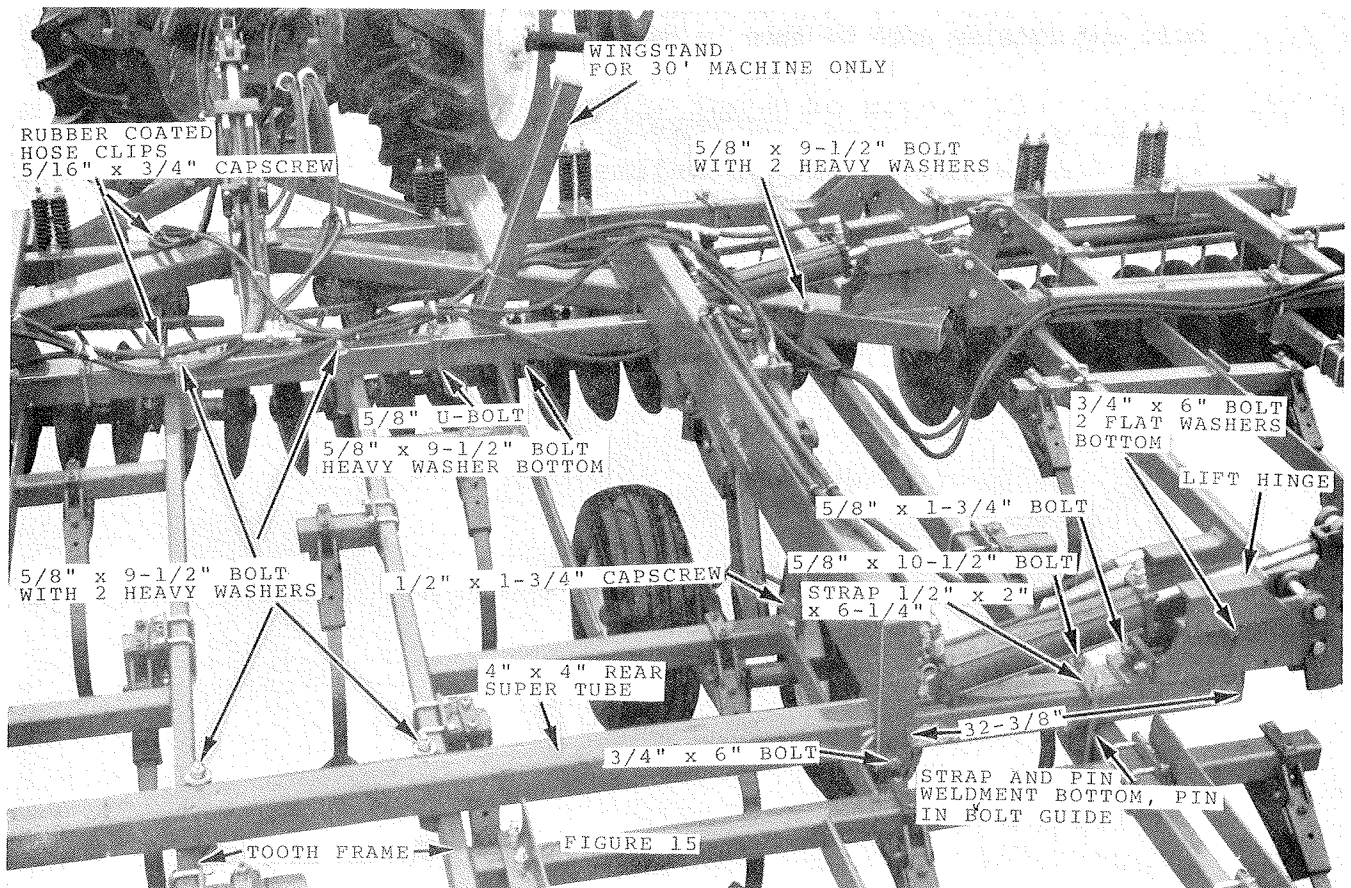

NOTE: Use boxes 5J-917, 5J-918, 5J-919 next.

17. Find the set up location page for your machine to determine where to attach extensions and shanks on machine center section.

Some of the following notes may apply to your machine.

- A. It may be easier to mount optional sweeps or points to shanks before mounting to machine.
- B. Most extensions mount around 2" x 4" tubes with 1/2" x 3-1/4" deep U-bolts, nuts and lockwashers.
- C. Some shanks may mount under roller harrow brackets.
- D. Two extensions used for 6 inch spacing use 3/8" x 5-1/2" x 6" plates, 1/2" x 2" capscrews instead of U-bolts where mounted to 1/2" tooth frame plate.
- E. The location of shanks indicates its center.

FOR ASSEMBLY OF 27' AND 30' MACHINES ONLY GO TO STEP 28.

NOTE: Use box 7J466 next.

18. Attach rear hinge weldments to 4" x 4" rear super tube. Position hole nearest the 1-1/4" holes of the hinge weldments over the 4" x 4" rear super tubes outside bolt guide. Fasten in place with 5/8" x 6" bolts, heavy washers, lockwashers and nuts. Fasten inside of hinge weldments with a 1/2" x 2" x 6-1/4" strap (on bottom) 5/8" x 6" bolts, lockwashers and nuts. The distance between center of 1-1/4" hinge pin hole and outside edge of tube weldment must be 38-1/2 inches.
19. Attach lift hinges of front wing frames to center frame with 1-1/4" x 7-5/8" pins and 1/4" x 2" roll pins. Attach rear wing frames to rear hinge weldments with 1-1/4" x 6-1/8" pins, thin washers and 1/4" x 2" roll pins. Mount front wing stand on outside front wing frame tube in line with front 3"x4" tube on center frame with 3/8" x 5" capscrews, lockwashers and nuts.

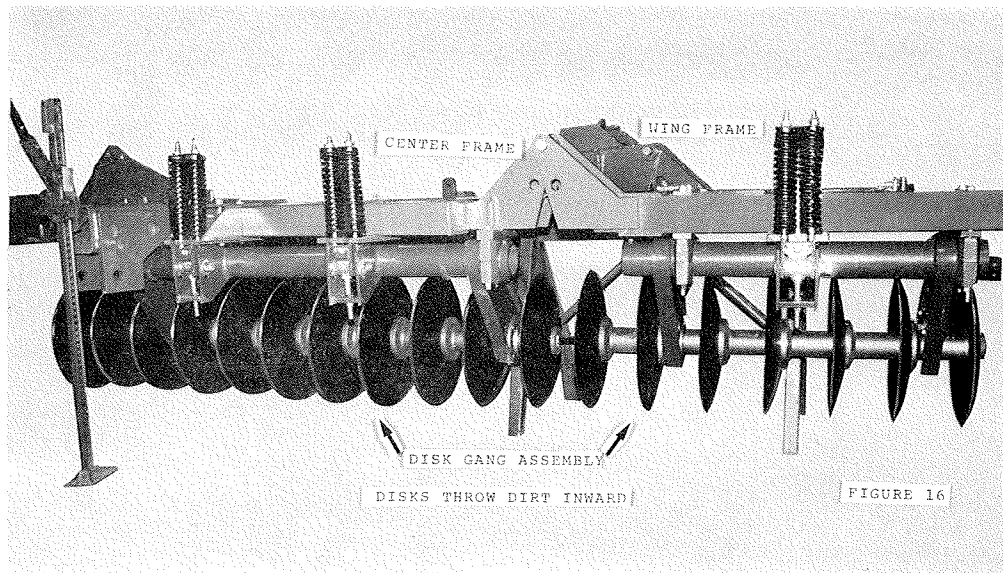

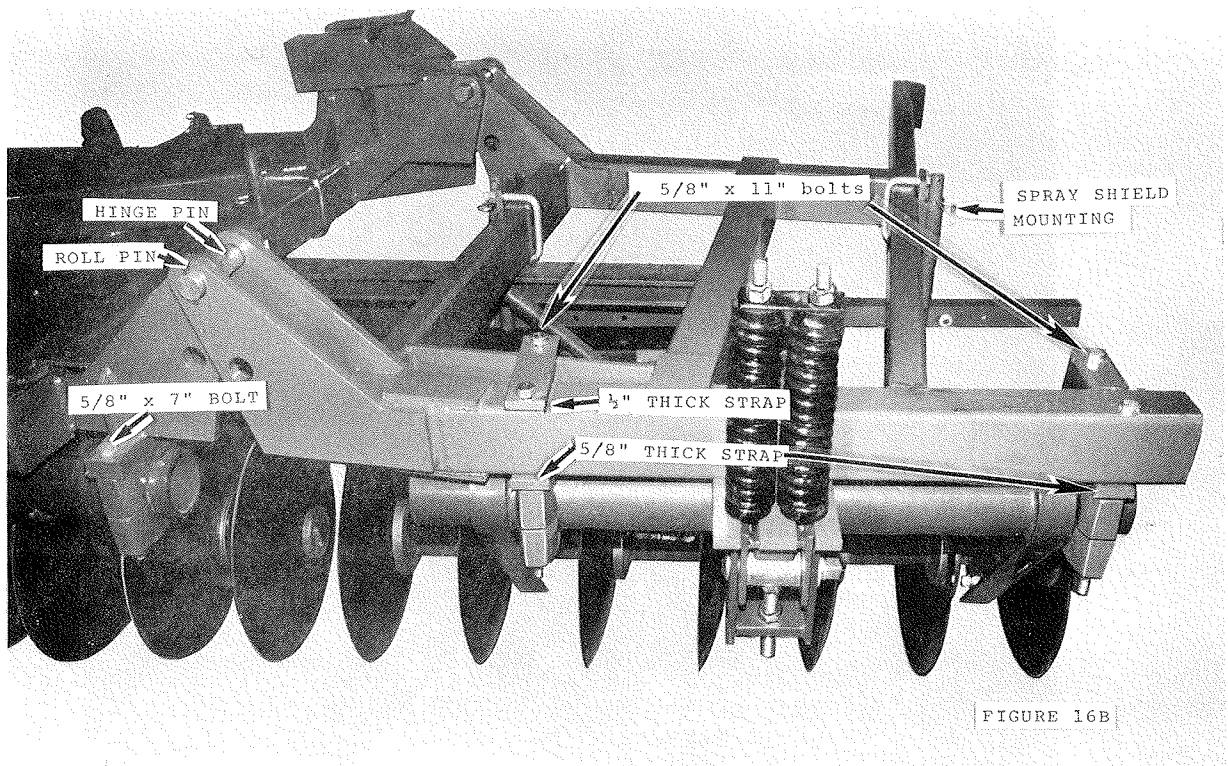
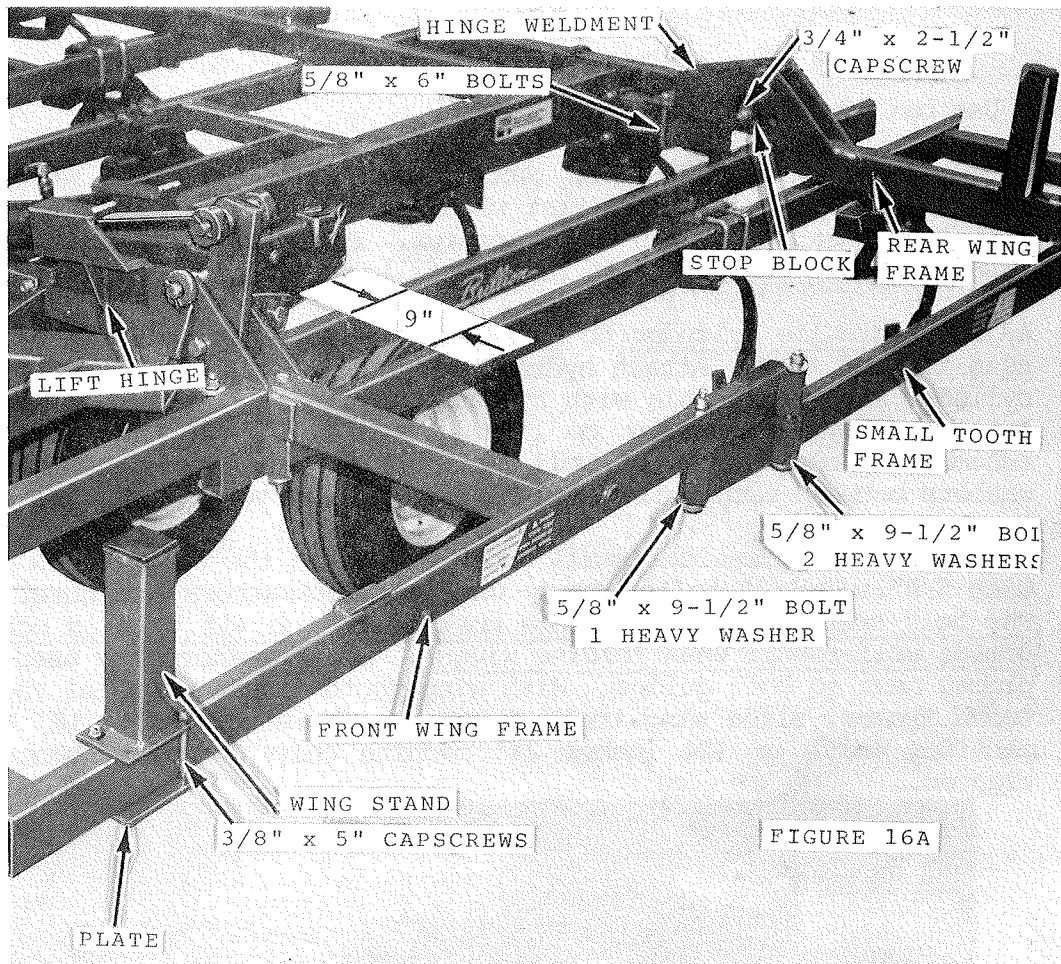

NOTE: Use box 6J-43 next.

20. Attach folding linkage next. Attach lift links to front wing frames with 1-1/4" x 5-3/8" pins, flat washers and 1/4" x 2" roll pins. The lift link must have notch toward center. Place an equal number of flat washers on each side of lift link to fill the space.

Adjust hydraulic cylinder to 26-1/4 inches retracted pin centers if it is a tie rod type. Attach hydraulic cylinder base end to center frame cylinder anchor with pin with hydraulic cylinder in extended position. Attach hydraulic cylinder to lift link with 1" x 7-1/2" pin, roller assemblies, and 1/4" x 2" roll pins. Place an equal number of flat washers between each roller and lug of cylinder yoke.

21. Attach the two identical small tooth frames to the wing frames loosely with 5/8" x 9-1/2" bolts, heavy washers, lockwashers and nuts. NOTE: The bolt head at the lift hinge must be on top (if this is not done, damage will result when folding wings). Heavy washers are used in all places next to bolt guides. With wing tooth frames parallel to center tooth frames, slide wing tooth frames to obtain (9 inches 18' and 21' machines only) or (24 inches 24' machine only) between frames, then tighten.

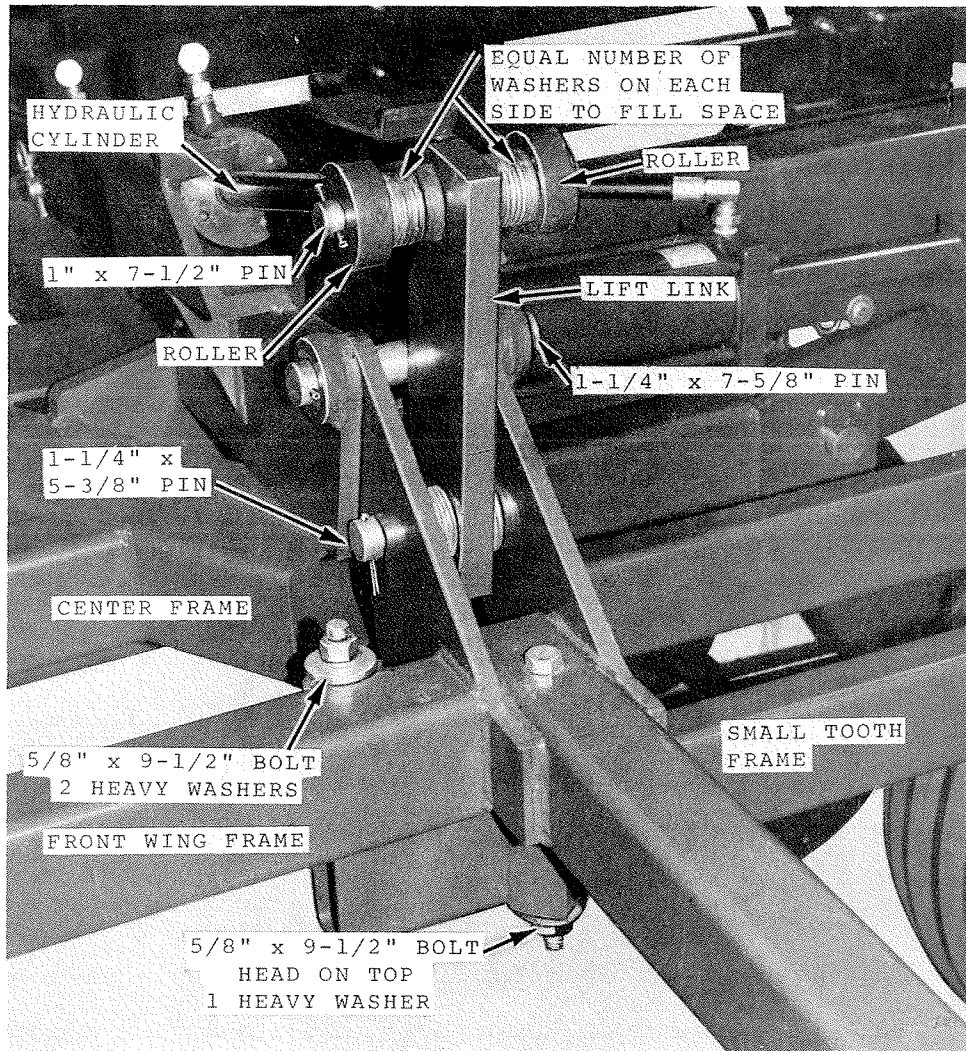

NOTE: Next use boxes 6J-129, 6J-681 (18' only) and 6J-697 (21' and 24' only).

22. Attach disk assemblies to wings as described in Step 5 with the exception of different bearing mounting. The bearings mount to the wing frame with 5/8" x 11" bolts through holes in the front of wing in three places and around the outside of the support plate. Assemble with 5/8" plates between bearings and bottom of wing frame, 1/2" plates on top of frame, lockwashers, and nuts. The 24' model does not have the 1/2" plate bolted on to the top, outside end of the wing frame (See Figure 16B).
23. Assemble adjusting bolt weldments, cast iron U-bolt clips, coupler weldments, and long U-bolt as described in Step 6.
24. Attach spring holders as described in first part of Step 7.
25. Install Springs with a cap on both ends (having flat sides outward) on long U-bolts resting on spring holders. NOTE: On 21' and 24' model wings another smaller spring must be installed inside larger springs. Place a 3/16" x 2" x 4-1/2" strap on U-bolts with lock nuts tightened initially to expose 1" thread.
26. Attach four wing stop blocks to four hinge weldments with 3/4" x 2-1/2" capscrews, nuts and lockwashers. Turn block for initial setup to hold wings level with center.
27. Install the anchor assemblies to the wings next. To install, slide the two straps around the rear 3" x 4" tube on the wing, with the lug up. Match the 4 holes in the end plate with the 2" x 4" tube that forms the end of the wing and bolt loosely with 1/2" x 3-1/2" capscrews, lockwashers and nuts. Use a 5/8" x 6" capscrew to fasten the straps around the 3" x 4" tube and two 1/2" x 5-1/2" capscrews and a flat strap to fasten the angle to the 2" x 4" tube of the tooth frame. Do not tighten the bolts.

Now install the gage wheel arm. Note that the tire is toward the outer end of the wing. Use the 1-1/4" diameter pins with the locking tabs. On some gage wheel arms it may be necessary to place three machinery bushings between the lugs on the anchor assembly to fill up the space and provide clearance for the actuating arm on the gage wheel. This can be done by sticking the pin through the inner lug and sliding on the bushings, then, with the pin and bushings flush; slide in the gage wheel arm and insert the pin the rest of the way. Lock the pin in place with a roll pin. The tab on the pin locks around the lug to stop the pin from turning.

Now line the wheel up parallel with the wing frame by shifting the anchor assembly. Bolt the anchor assembly tight.

Take an eye bolt and run a nut on most of the thread length. Then stick the eye bolt through the tube on the anchor assembly lug, with the eye toward the rear of the machine, and put on another nut. Now install the ratchet jack.

The recommended tire size is 7:60 x 15 6 ply inflated to 24 psi. It is also recommended that on the initial set up, the ratchet jack be retracted most of the way so that the tire does not pry sideways when folding and unfolding the wings.

If the unit is equipped with hydraulic gage wheels, the set up is the same except hydraulic cylinders are used in place of the ratchet jacks. These cylinders are a continuation of the series cylinders used for machine raising. See page 31 for hydraulic cylinder and hose layout.

It is important to check that the fittings and the wing gage wheel cylinder do not hit the fittings on the wing fold cylinders when the wings are folded. When tying down the hydraulic hoses check to make sure they will not be pinched when folding the wings.

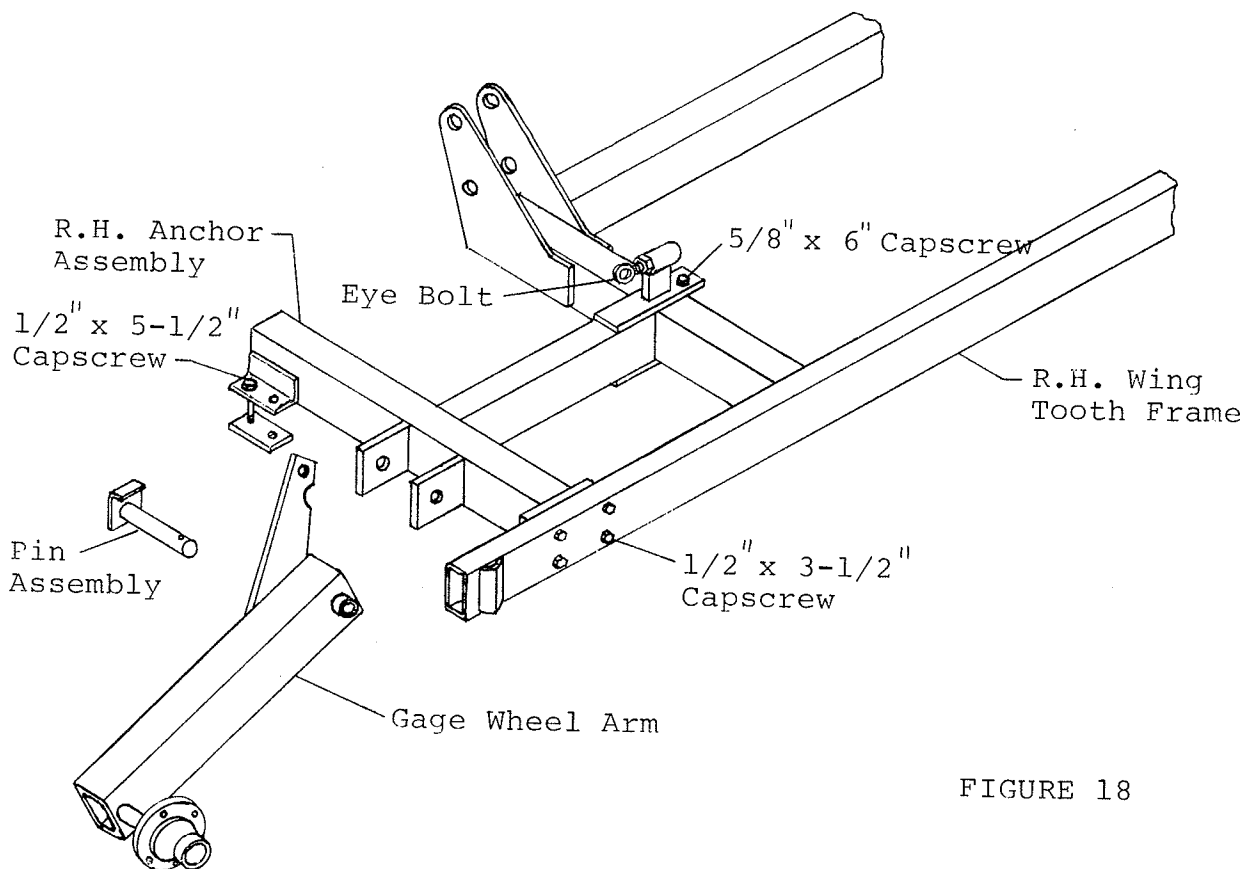

FIGURE 18

FOR REMAINDER OF ASSEMBLY OF 24' MACHINES ONLY GO TO STEP 39.

FOR REMAINDER OF ASSEMBLY OF 27' AND 30' MACHINES ONLY CONTINUE HERE.

NOTE: Use box 6J-132 next.

28. Attach a lift hinge to the 4" x 4" rear super tube next. Use 5/8" x 1-3/4" bolts, lockwashers and nuts to attach lift hinge to angle on 4" x 4" rear super tube. Use two 3/4" x 6" bolts, four flat washers (on bottom), two lockwashers and two nuts to complete attachment of lift hinge.
29. Attach front wing frames to center frame lift hinges with 1-1/4" x 7-5/8" pin and 1/4" x 2" roll pins. Support front of wing frame parallel to center frame. Attach front of front wing frames to center frame with 1-1/4" x 6-1/8" pins, thin washers (on outside) and 1/4" x 2" roll pins.

Attach rear wing frames to rear wing lift hinges with 1-1/4" x 7-5/8" pins and 1/4" x 2" roll pins.

30. Attach folding linkage next. Attach lift links to front wing frames with 1-1/4" x 5-3/8" pins, flat washers and 1/4" x 2" roll pins. The lift link must have notch toward center. Place an equal number of flat washers on each side of lift link to fill the space.

Adjust hydraulic cylinders to 26-1/4" inches retracted pin centers, if they are tie rod type. Attach hydraulic cylinder base end to center frame cylinder anchor with pin with hydraulic cylinder in extended position. Attach hydraulic cylinder to lift link with 1" x 7-1/2" pin, roller assemblies, and 1/4" x 2" roll pins. Place an equal number of flat washers between each roller and lug of cylinder yoke.

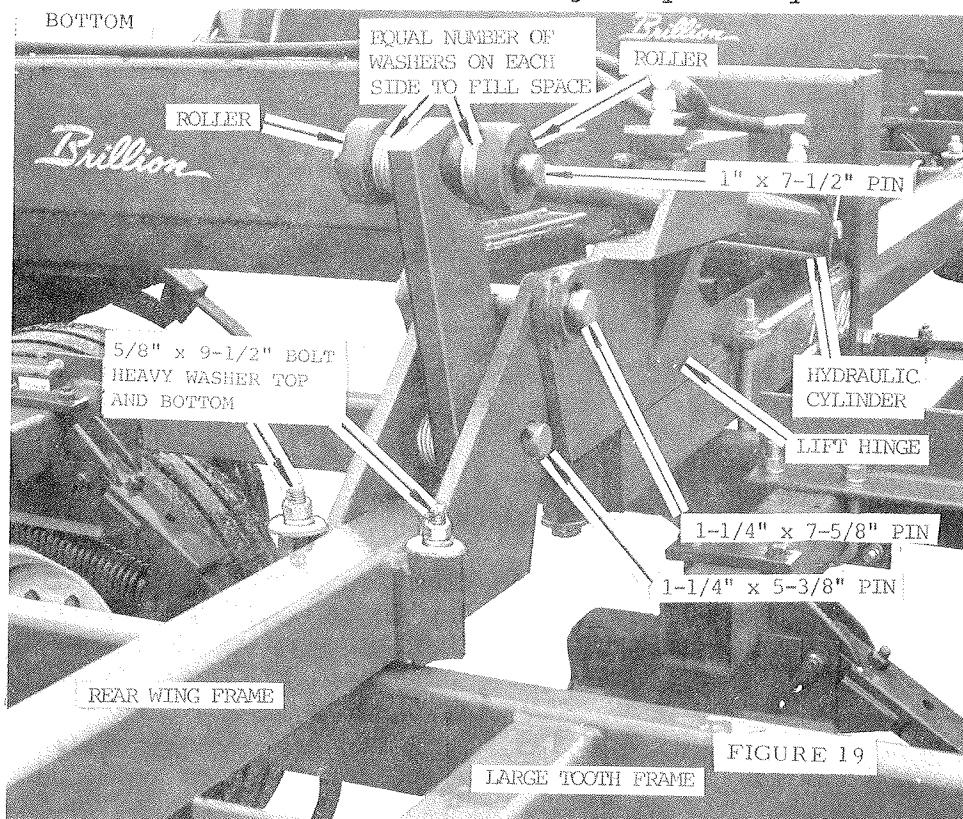

31. See next page for assembly figure for the following steps. Do not tighten hardware in Steps 31 through 35 until all associated parts are in place.

Attach the two remaining identical tooth frames to the wing frame with tire openings outward. Use 5/8" x 9-1/2" bolts, heavy washer on bottom, lockwashers and nuts for attaching front of tooth frames. Attach rear of each tooth frame to rear wing frame. For each joint use a 5/8" x 9 1/2" bolt, two heavy washers, one nut, and one lock washer.

Attach wing stands for the outside rear of machine with 5/8" x 9-1/2" bolts, heavy washers (on bottom), lockwashers, and nuts to connect tooth frames and wing frames as shown on figure on next page.

The wing stand for the rear outside of machine is for a 30' machine only. Attach the shorter vertical stand for 27' machines in the same position.

Attach vertical stand for 27' machines in the same position. Attach the front wing stands on the center section for the 30' machines as shown in figure 15. For front wing stands for 27' machine attach to center frame as shown below.

Attach a 1/4" x 4-1/2" x 6-3/4" plates to the top of the front wing frame as shown below with 5/8" U-bolts, lockwashers and nuts.

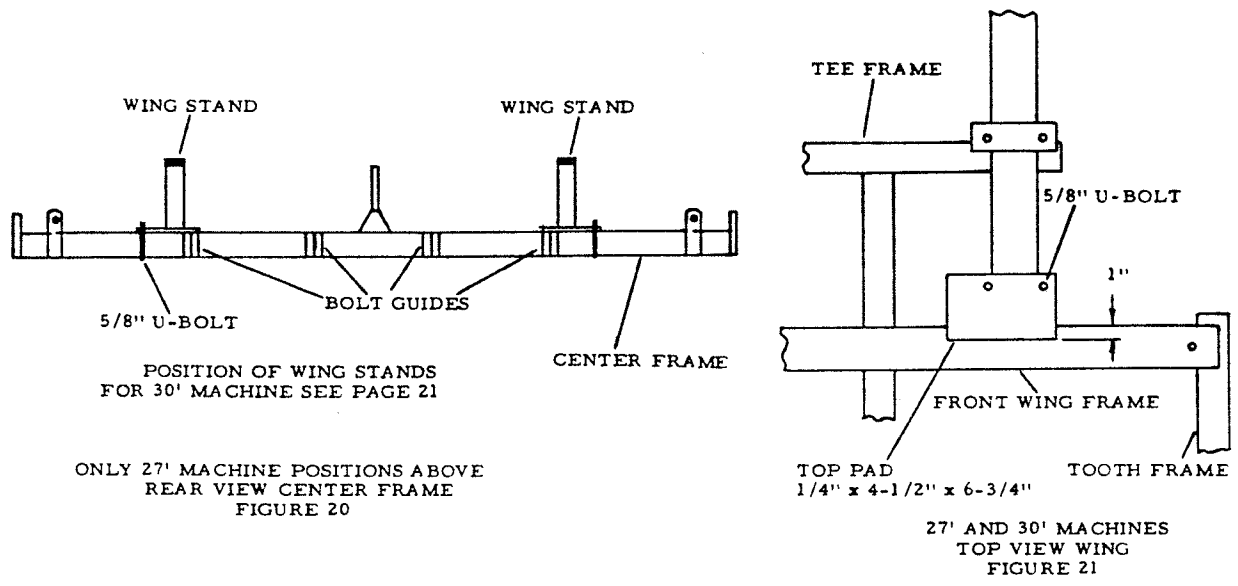

32. Attach tee wing frames to middle wing frame cross tubes loosely with 5/8" x 9-1/2" bolts, heavy washers on bottom, 1/2" x 2" x 5-3/4" strap on top, lockwashers and nuts. Attach also to tooth frame with 1/2" U-bolts (same as used for shank extensions), lockwashers and nuts loosely.

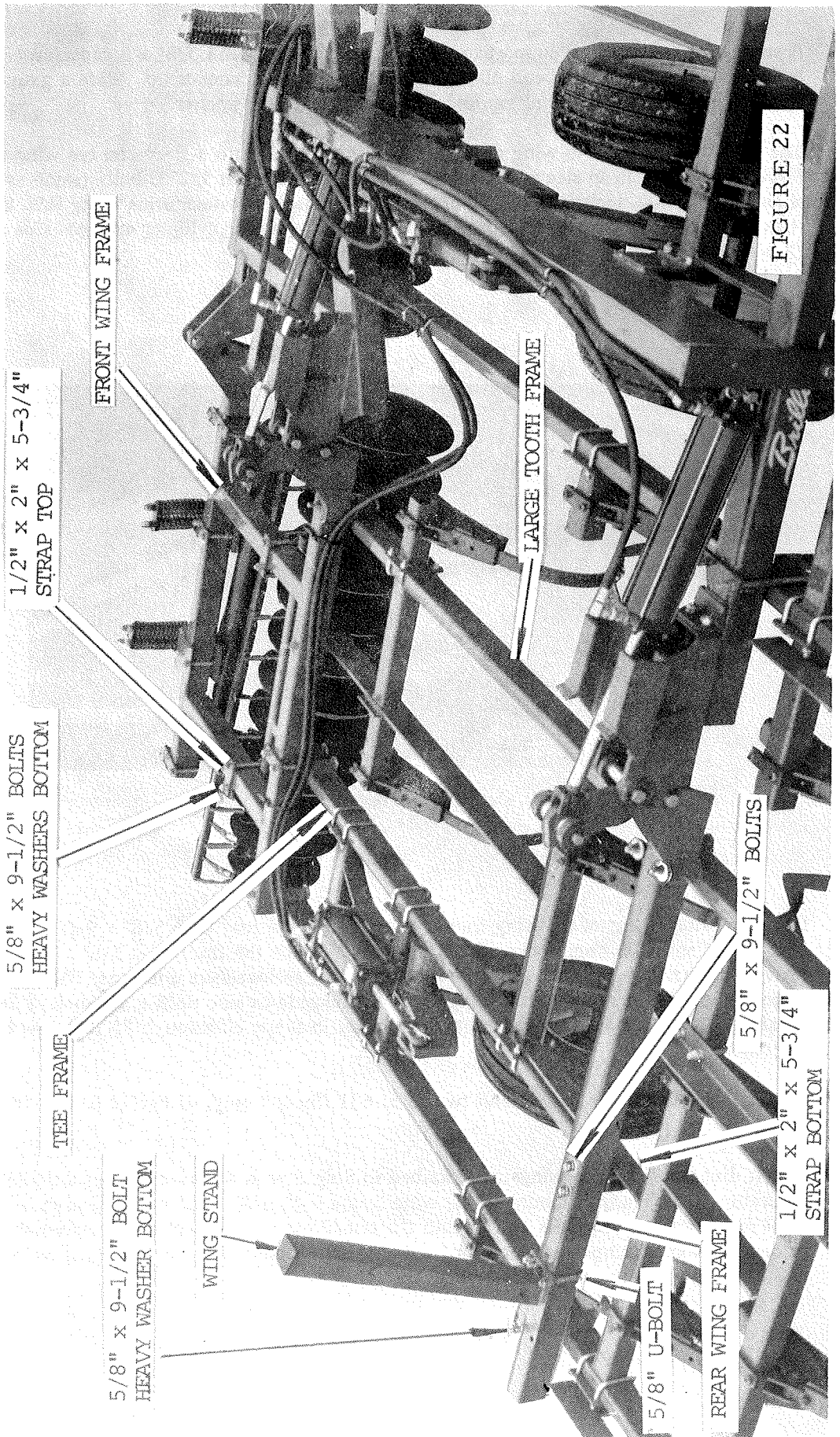
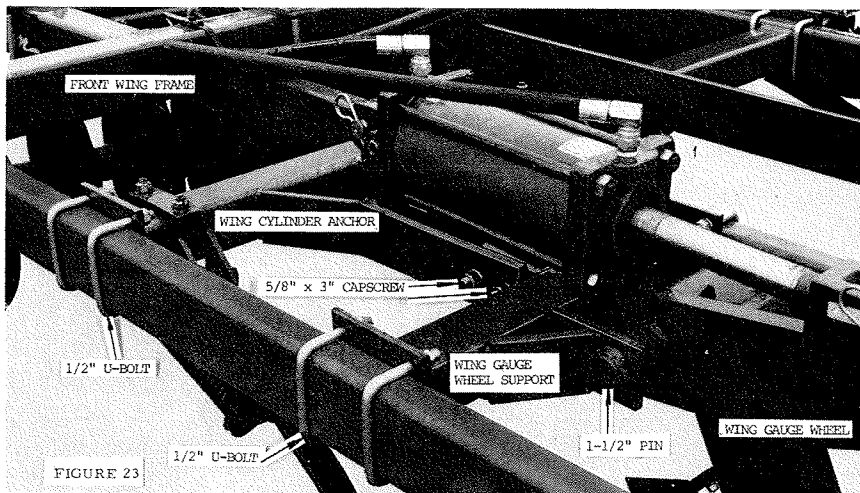

FIGURE 22

33. Fasten wing gauge wheel support to wing cylinder anchor with 5/8" x 3 capscrows, lockwashers and nuts with end plates parallel and cylinder anchor up. Slide a gauge wheel arm on assembly with lift link up and in line with cylinder anchor.
34. The 1-1/2" pin welded to wing gauge wheel support goes into a sleeve on tee wing frame. Place the 1-1/2" pin in sleeve and fasten to tooth frames with 1/2" U-bolts (same as used for shank extensions), lockwashers and nuts. Attach wheels to wheel arms using 9.5L x 15 6 ply tires inflated to 32 psi. Attach 9J-487 (4-3/4 bore) hydraulic cylinder on right side and 9J-483 (3-3/4 bore) hydraulic cylinder on left side.



35. Complete attachment of tee wing frame next. Attach the rear with 5/8" x 9-1/2" bolts, 1/2" x 2" x 5-3/4" straps bottom, lockwashers and nuts. Attach the front with 5/8" x 9-1/2" bolts, heavy washers bottom, 1/2" x 2" x 5-3/4" straps top, lockwashers and nuts. With tooth frames of center and wing parallel slide wing tooth frames side to side until a distance of 28 inches is obtained between tooth frames. All the hardware in Steps 32 through 35 can now be tightened.

NOTE: Next use boxes 7J-963 and two of 6J-681 (for 27' only) or two of 6J-697 (for 30' only).

36. Attach disc assemblies to wings as described in Step 5 with the exception of different bearing mounting. The bearings mount to the wing frame with 5/8" x 11" bolts through holes in the front of wing in three places and around the outside of the support plate. Assemble with 5/8" plates between bearings and bottom of wing frame, 1/2" plates on top of frame, lockwashers, and nuts. (See Figure 16B as reference)

37. Assemble adjusting bolt weldments, cast iron U-bolt clips, coupler weldments, and long U-bolts as described in Step 6.
38. Attach spring holders as described in Step 7.
39. Install springs with a cap on both ends (having flat sides outward) on long U-bolts resting on spring holders. Note: On 30' models another smaller spring must be installed inside large spring. Place a 3/16" x 2" x 4-1/2" strap on U-bolts with locknuts tightened initially to expose 1" thread.

FOR REMAINDER OF ASSEMBLY OF ALL MACHINES CONTINUE HERE.

NOTE: Use boxes 5J-917, 5J-918, 5J-919 next.

40. Find the set up location page for your machine to determine where to attach extensions and shanks on machine.
 - A. It may be easier to mount optional sweeps or points to shanks before mounting to machine.
 - B. Most extensions mount around 2" x 4" tubes with 1/2" x 3-1/4" deep U-bolts, nuts and lockwashers.
 - C. Some shanks may mount under roller harrow brackets or spike tooth harrow supports.
 - D. Two extensions used for 6 inch spacing use 3/8" x 5-1/2" x 6" plates, 1/2" x 2" capscrews instead of U-bolts where mounted to 1/2" tooth frame plate.
 - E. The location of shanks indicates its center.

NOTE: Use two of box 6J-986 next.

41. Attachment of spike tooth harrow is next (if equipped).
 - A. Attach the support tubes to the top side of the rear two tooth bars as shown in the setup locations, with 5/8" x 8-1/2" bolts, nuts, lockwashers and 1/2" x 2" x 6" long straps. NOTE: All the tubes are the same.
 - B. Set the spike tooth harrow sections under the support tubes with the spikes angled rearward. All sections of equal width are the same. See setup location pages for proper positions.
 - C. Attach the vertical support chains to the support tubes using 1/2" x 3" capscrews, flat washers, lockwashers and nuts. Normally the end link of the chain is used. Put the chains either inside or outside each pair of support tubes as necessary to get the chains as vertical as possible. On each drag section the chains must either be between or outside the support tubes to hang and work properly.
 - D. For initial setting of draft chain, hook second link between lugs and fasten with 7/16" x 1-1/2" capscrew and locknuts. NOTE: Draft chains may not be straight back.

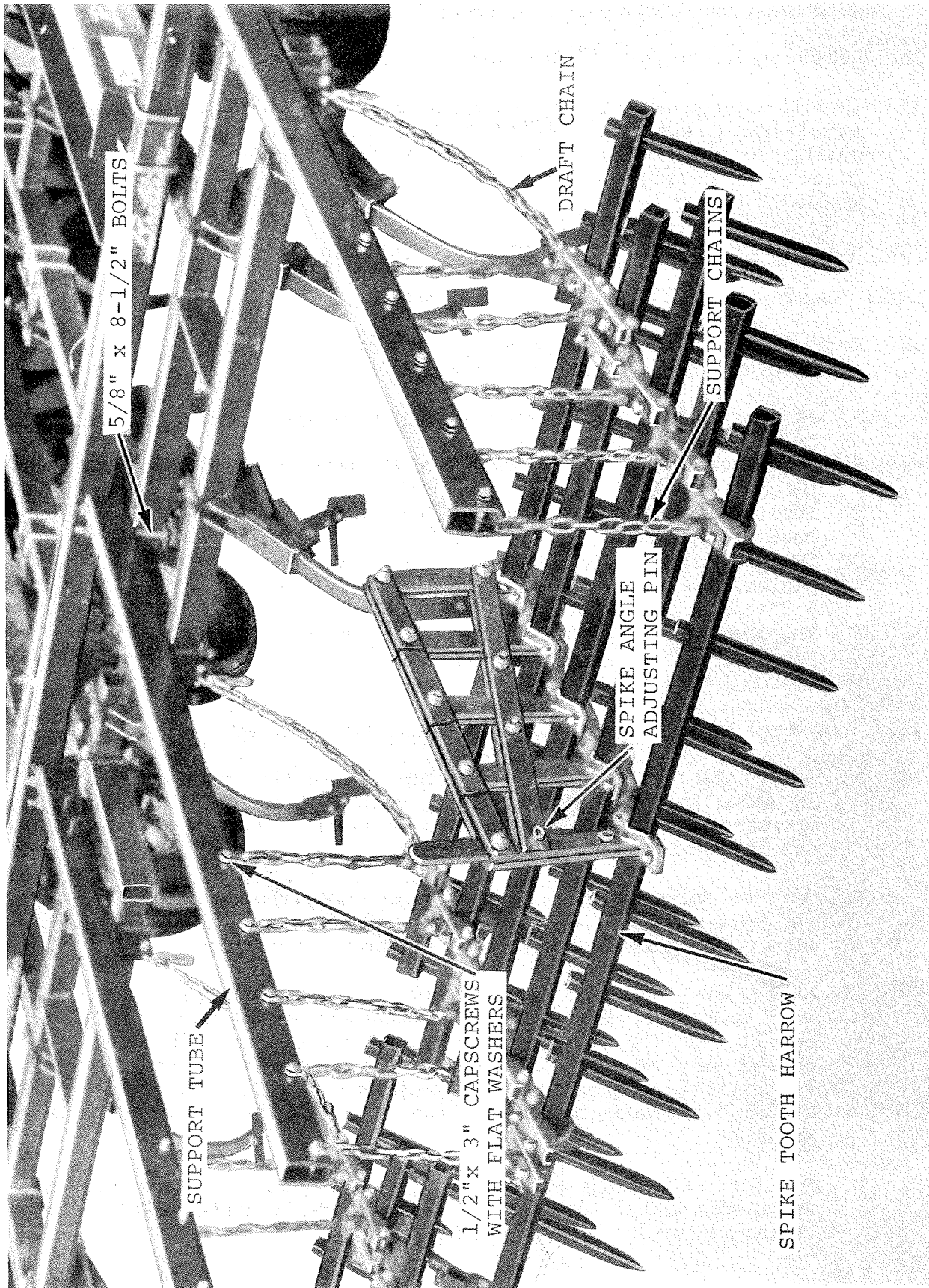

NOTE: Use box 6J-896 (for 24', 27' and 30') and 6J-897 (for 24' and 27') or 6J-898 (for 30').

42. Attachment of two gang roller harrows (if equipped).

- A. Secure roller harrow brackets to rear of machine frame with 5/8" U-bolts, flat washers, lockwashers and nuts as shown on set up location page for your machine.
- B. Attach roller harrow extensions to roller harrow brackets with 5/8" x 5-1/2" capscrews and locknuts. Tighten nuts so extensions are free to pivot vertically. Your machine may have side to side adjustable extensions. See setup locations pages for locations.
- C. Install roller harrow assemblies to extension assemblies. See set up location pages to determine whether to adjust extension to the left or right. See set up location pages for matching proper harrow width section to extensions. NOTE arrows on upper frame of harrow assemblies must point in direction of travel. Use 5/8" x 2-1/4" special capscrews with head inside frame for attaching extensions to roller harrow assemblies. Tighten nuts so roller harrow assemblies can pivot freely.
- D. For initial setup raise bottom of both rollers approximately 3" above bottom sweeps. Lock in place with 1/2" x 1-1/2" capscrews, lockwashers and nuts.
- E. For initial setup install 5/8" x 4-3/4" clevis pin and hair pin in bottom of the four holes in a group with the extension on top.
- F. Attach extension springs in the rear bottom holes of the roller harrow brackets. Attach spring handle to opposite end of extension springs. For initial setup hook spring handle in hole nearest handle over the special capscrew. Fasten with a hairpin cotter.
- G. Install 5/8" x 4-1/2" capscrews and locknuts in the top hole of roller harrow brackets. Tighten nuts so extensions are free to pivot vertically.

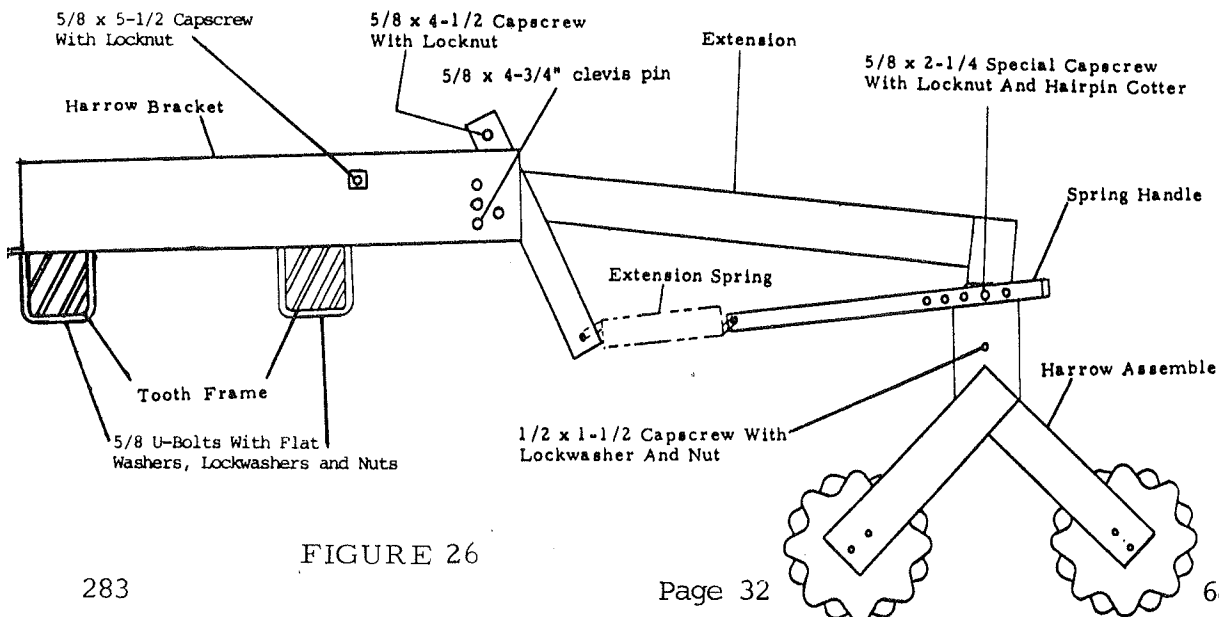

FIGURE 26

NOTE: Use box 6J-324 (24' only) or 6J-325 (27' and 30') next.

43. For depth control, install the hydraulic hoses as shown in Figure 27 (for 24' only) Figure 28 (for 24' machine with wing gage wheels) or Figure 29 (27' and 30' only). The cylinders are connected in series and must be connected as shown.

Attach six hose clips to the hoses at three tapped holes on the center frame with 5/16" x 3/4" capscrews and lockwashers. Thread hoses through hose holder on drawbar.

44. For wing fold, install hydraulic hose and fitting as shown in Figure 30 (for 24' only) or Figure 31 (27' and 30' only). Attach two hose clips to the hose at tapped hole near front of center frame with 5/16" x 3/4" capscrews and lockwashers. Thread hose through hose holder on drawbar. Tie hoses with plastic ties between cylinder anchor and middle of machine. Tie hose with plastic ties in front and rear of middle cylinder anchor 4" x 4" tube.

For 27' and 30' machines only attach hose clips to hoses for rear folding hydraulic hoses on top of tube weldments with 5/16" x 3/4" capscrews and lockwashers. Attach the remainder of the plastic ties to center hoses and wing hoses where required.

45. Bleed the depth control hydraulic cylinders by the procedure explained in operating instructions on page 5.
46. Bleed the wing lift cylinders by the procedure explained in operating instructions on page 6.

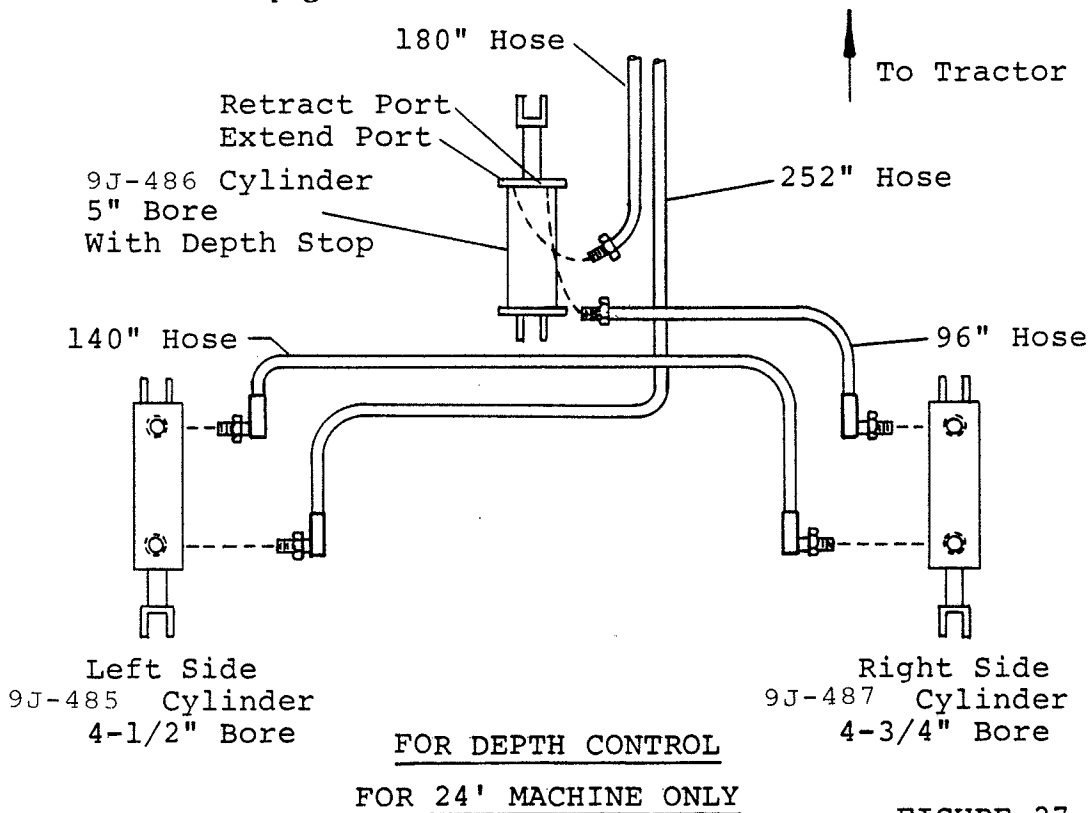
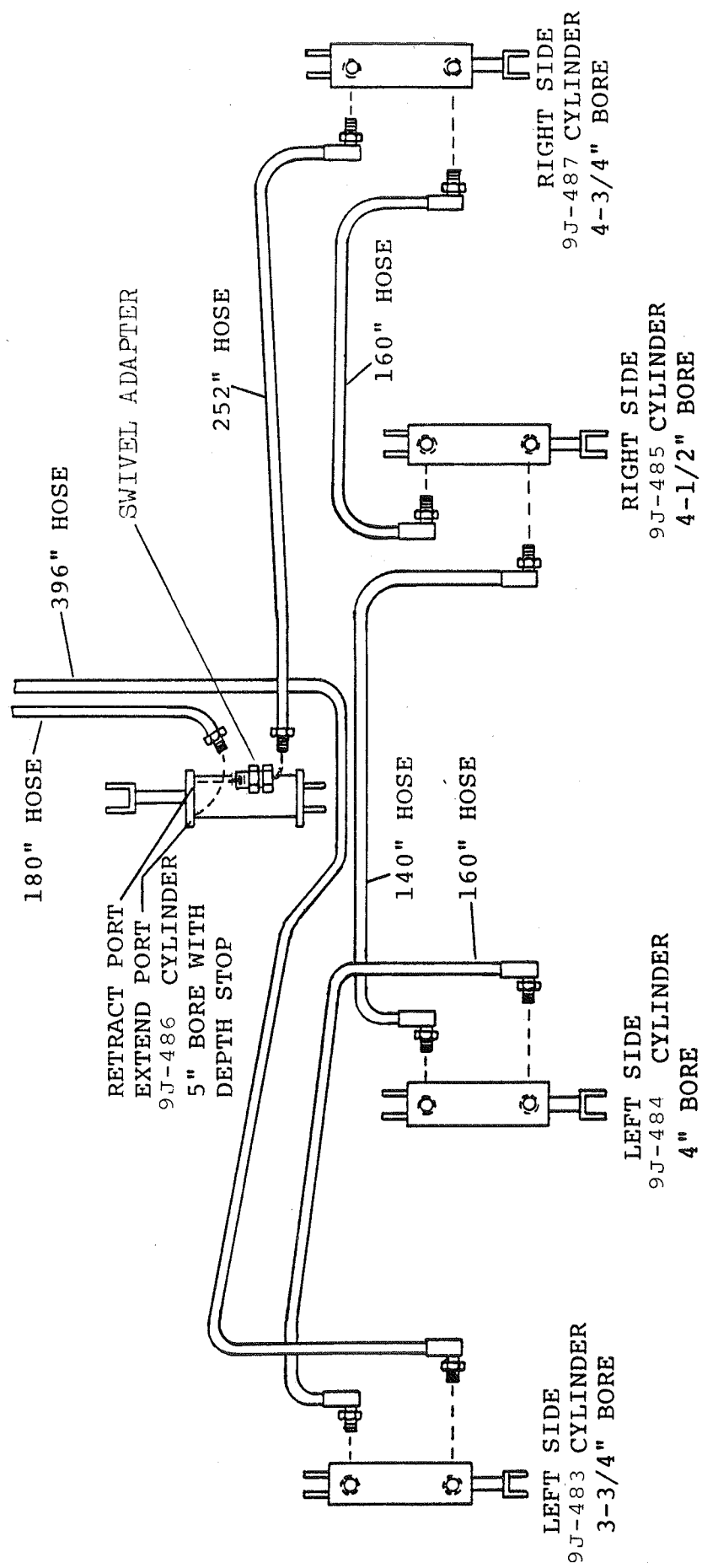

FIGURE 27
6J-160

TO TRACTOR



FOR DEPTH CONTROL
27' AND 30' MACHINES

FIGURE 28

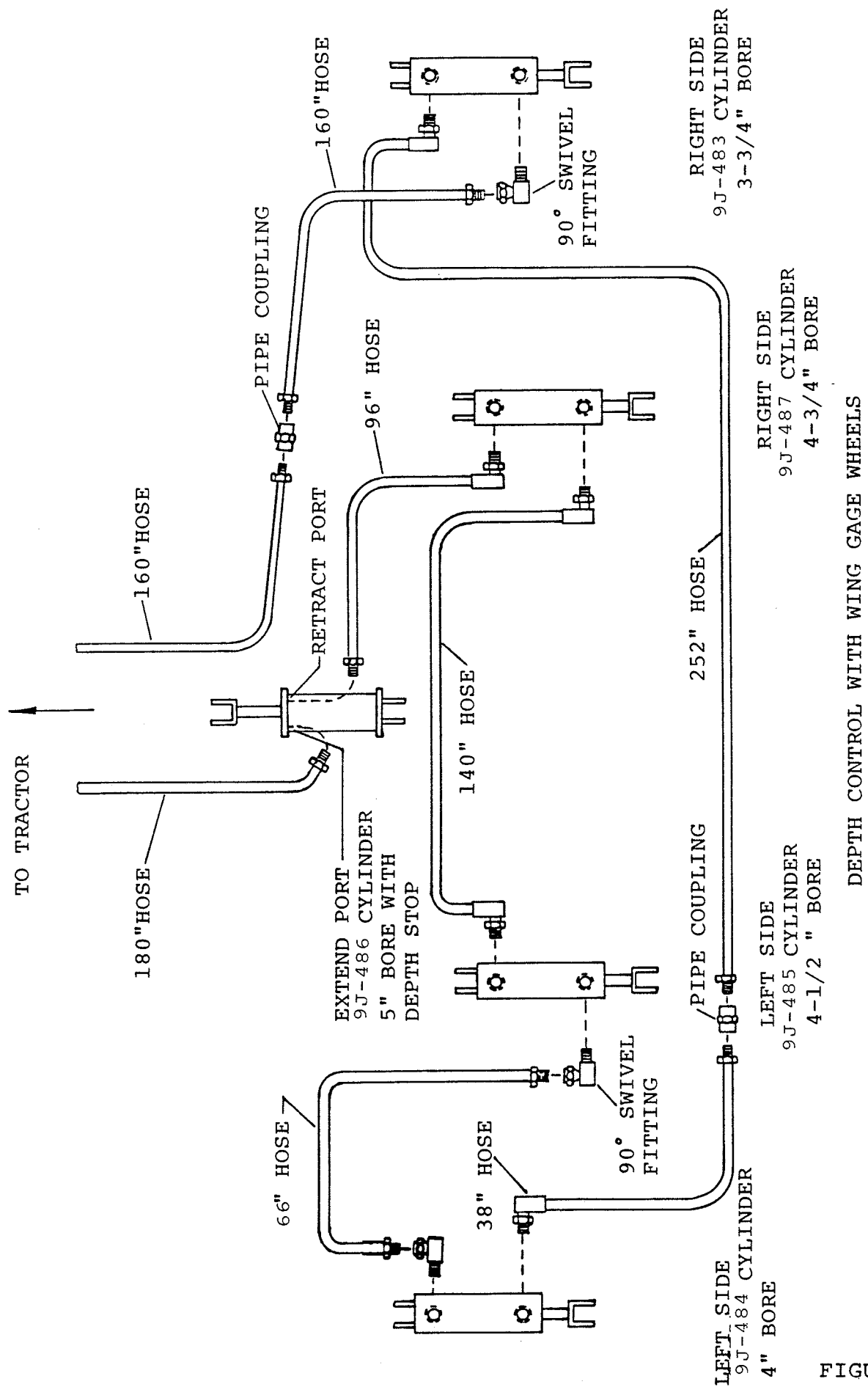

FOR 24' MACHINE ONLY

FIGURE 29

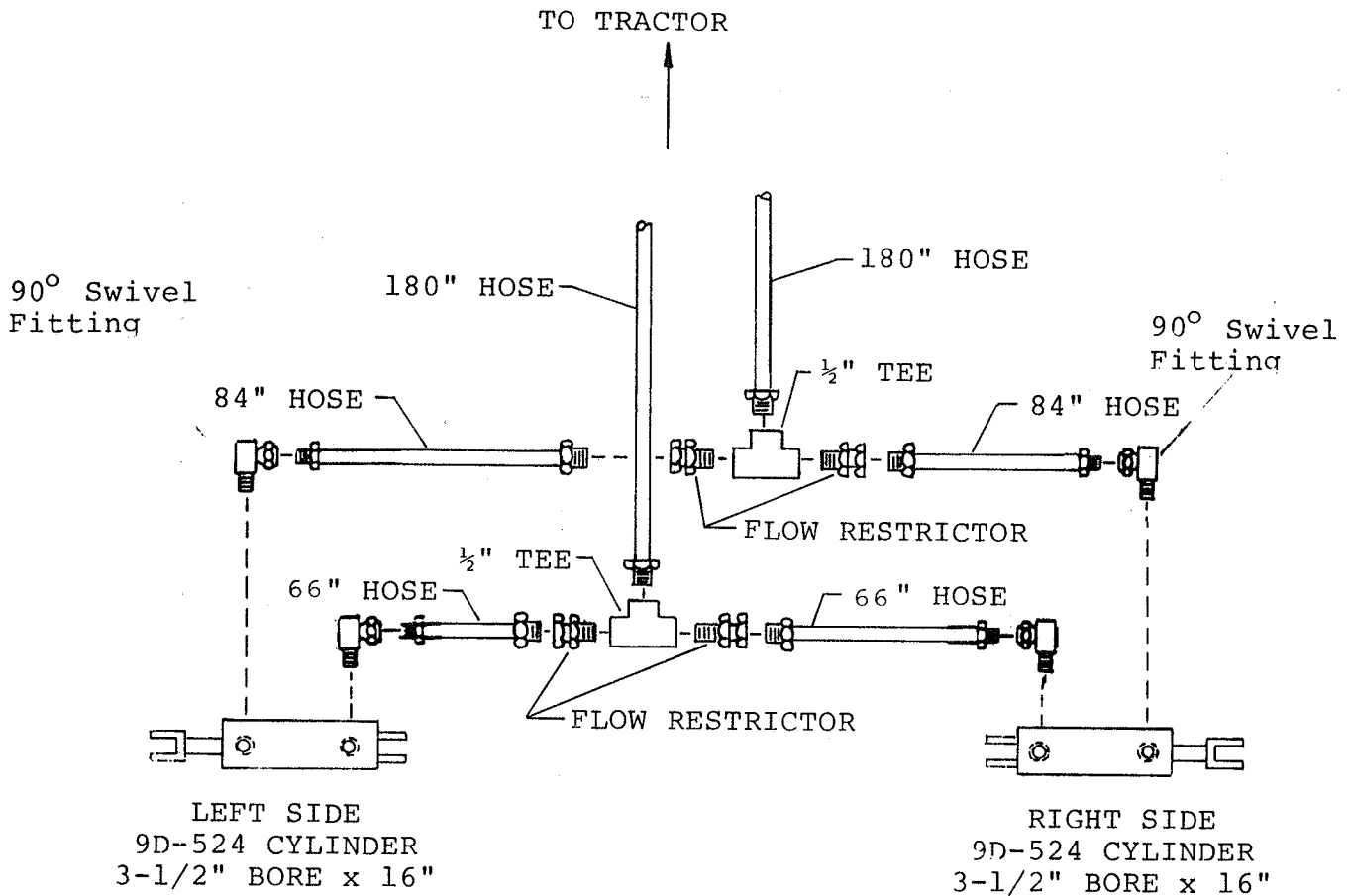

FOR 24' MACHINE ONLY

FOR WING FOLD

FIGURE 30

Install 90° swivel fittings so swivel end for hose points toward front of machine. Otherwise, fittings may be broken when wings are folded.

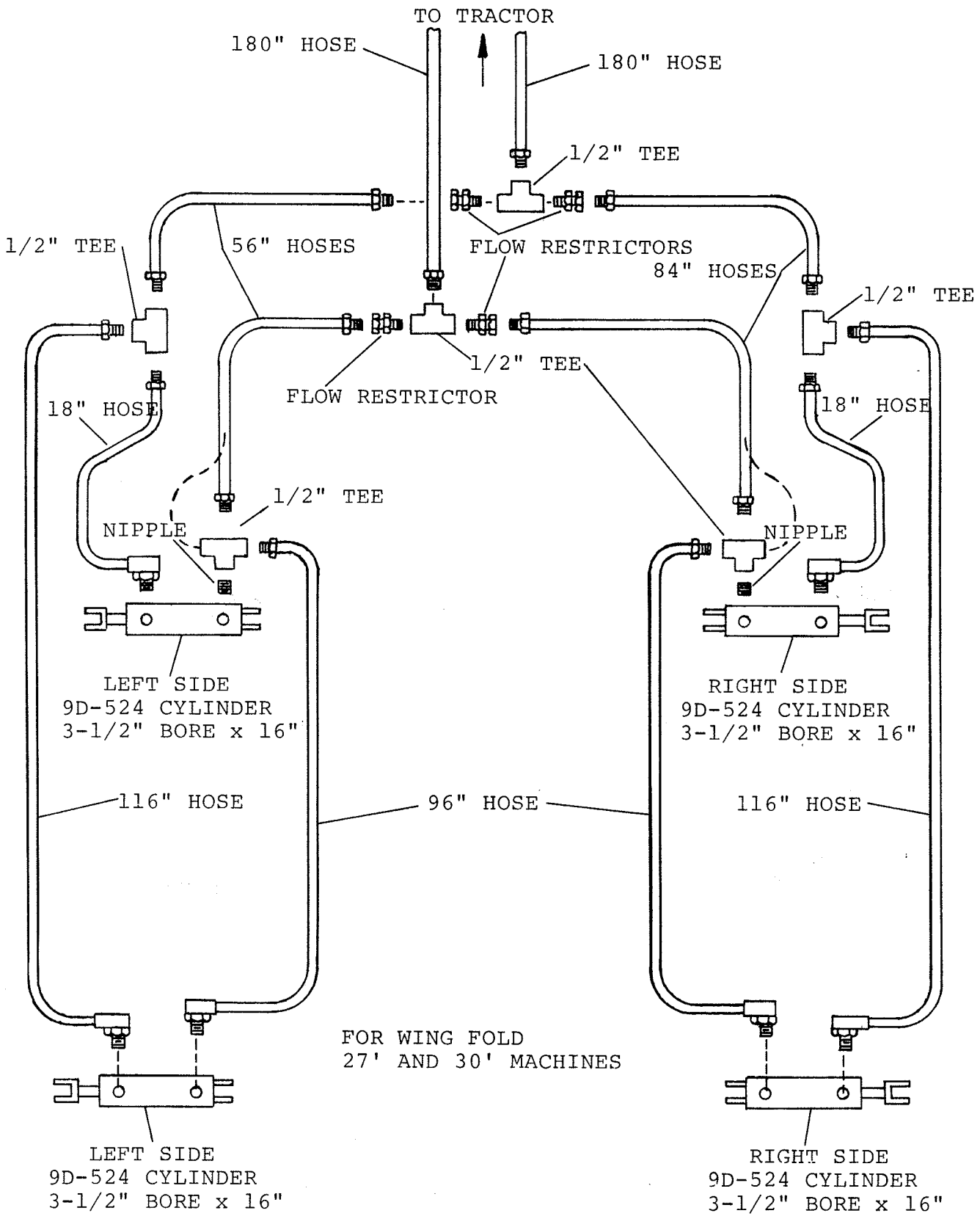
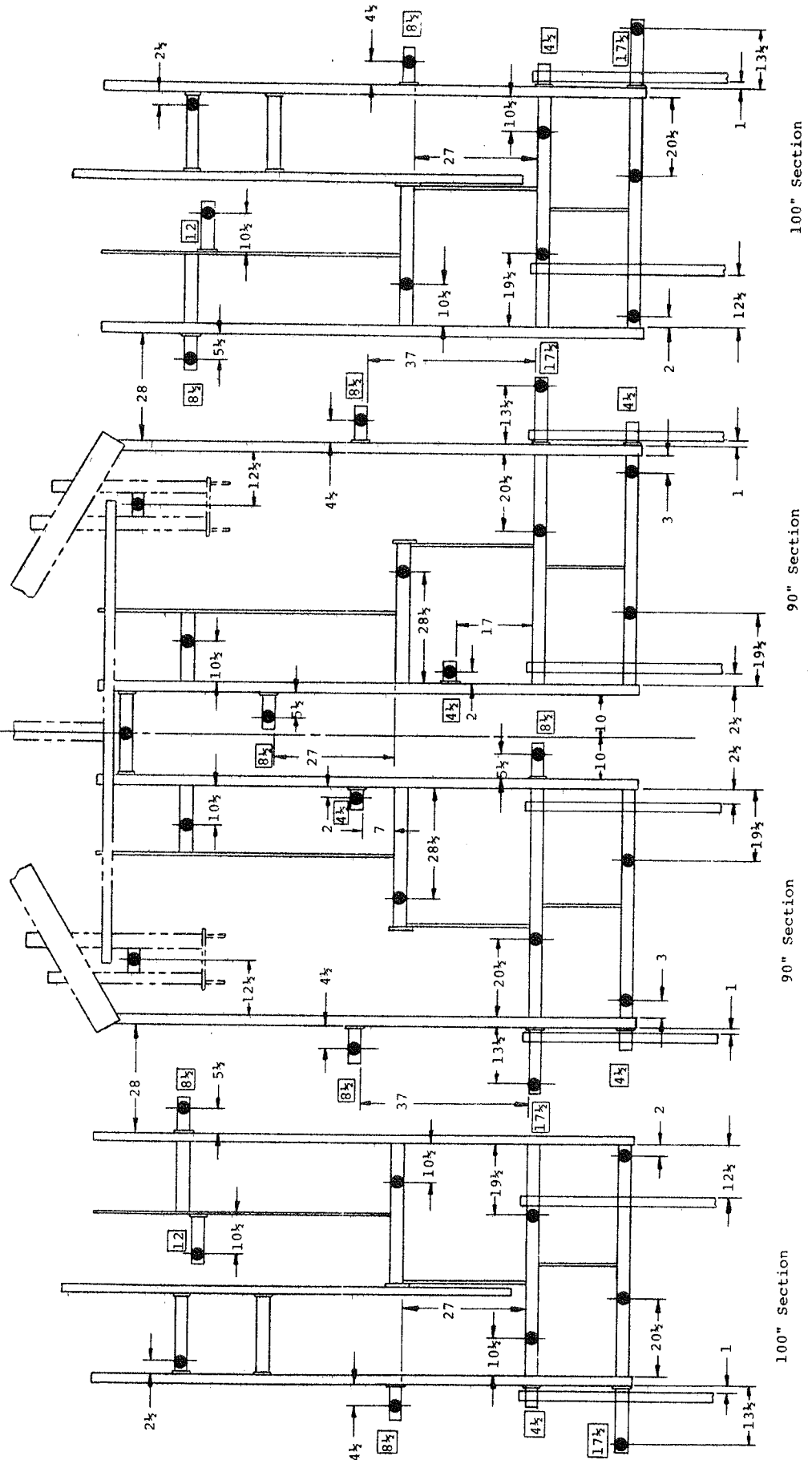
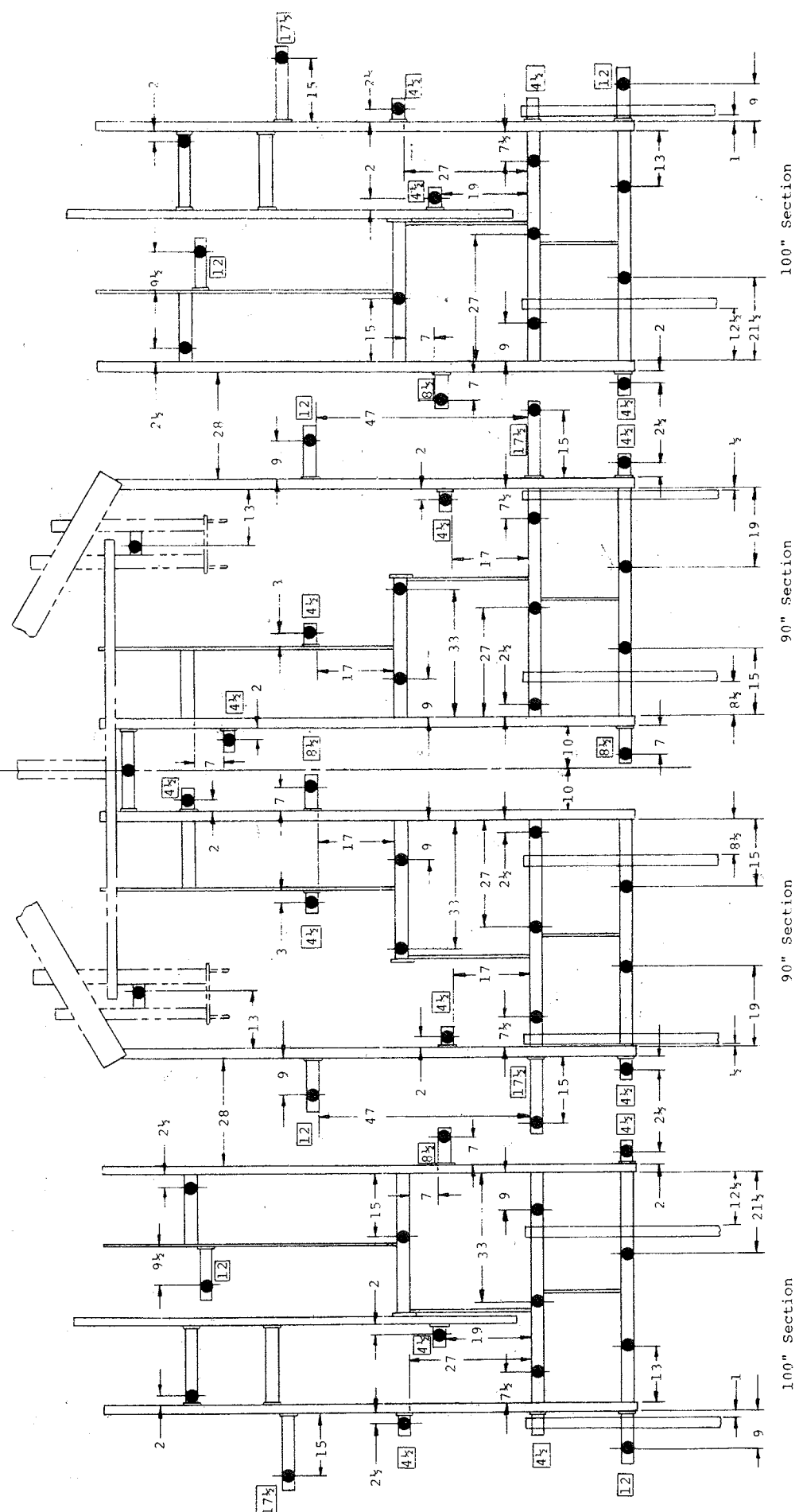

FIGURE 31

SGS-30
 Recommended Set Up Locations
 9" Field Cultivator Shank Spacing
 30' Working Width
 Spike Tooth Harrow Sections on Rear
 [8 1/2] Extension Length
 ● Shank Location
 21 Shanks Center 10 Shanks each Wing



S6S-30-1
 Recommended Set Up Locations
 6" Field Cultivator Shank Spacing
 30' Working Width
 Spike Tooth Harrow Sections on Rear
 Extension Length
 ● Shank Location
 31 Shanks Center 15 Shanks each Wing



SGR-24

- Recommended Set Up Locations
- 9" Field Cultivator Shank Spacing
- 24' Working Width
- 2 Gang Roller Harrows on Rear
- 8 1/2" Extension Length
- Shank Location
- 21 Shanks Center, 6 Shanks each Wing

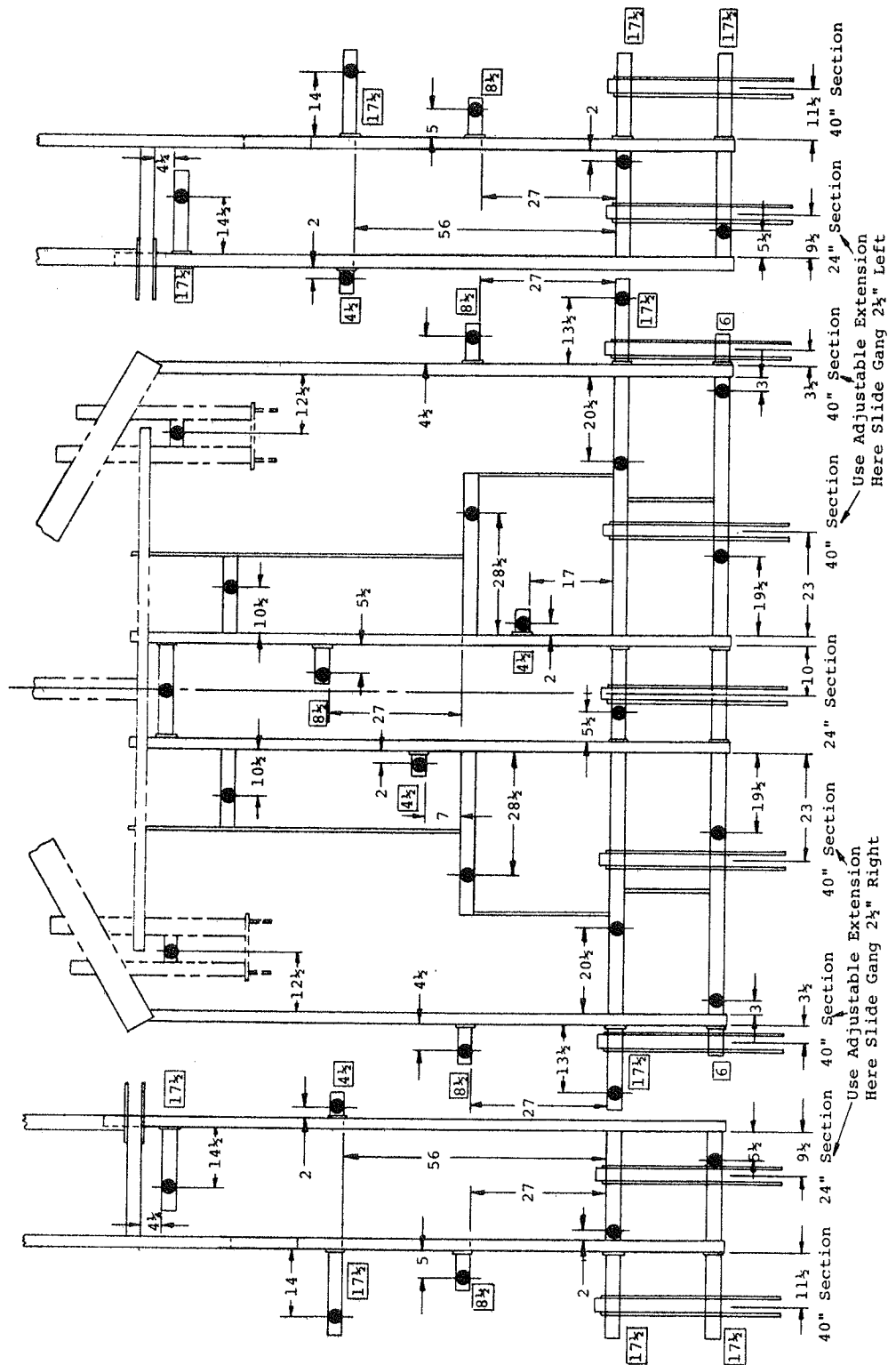

SGR-27
 Recommended Set-Up Locations
 9" Field Cultivator Shank Spacing
 27' Working Width
 2 Gang Roller Harrows on Rear
 8 1/2" Extension Length
 ● Shank Location
 21 Shank Center 8 Shanks each Wing

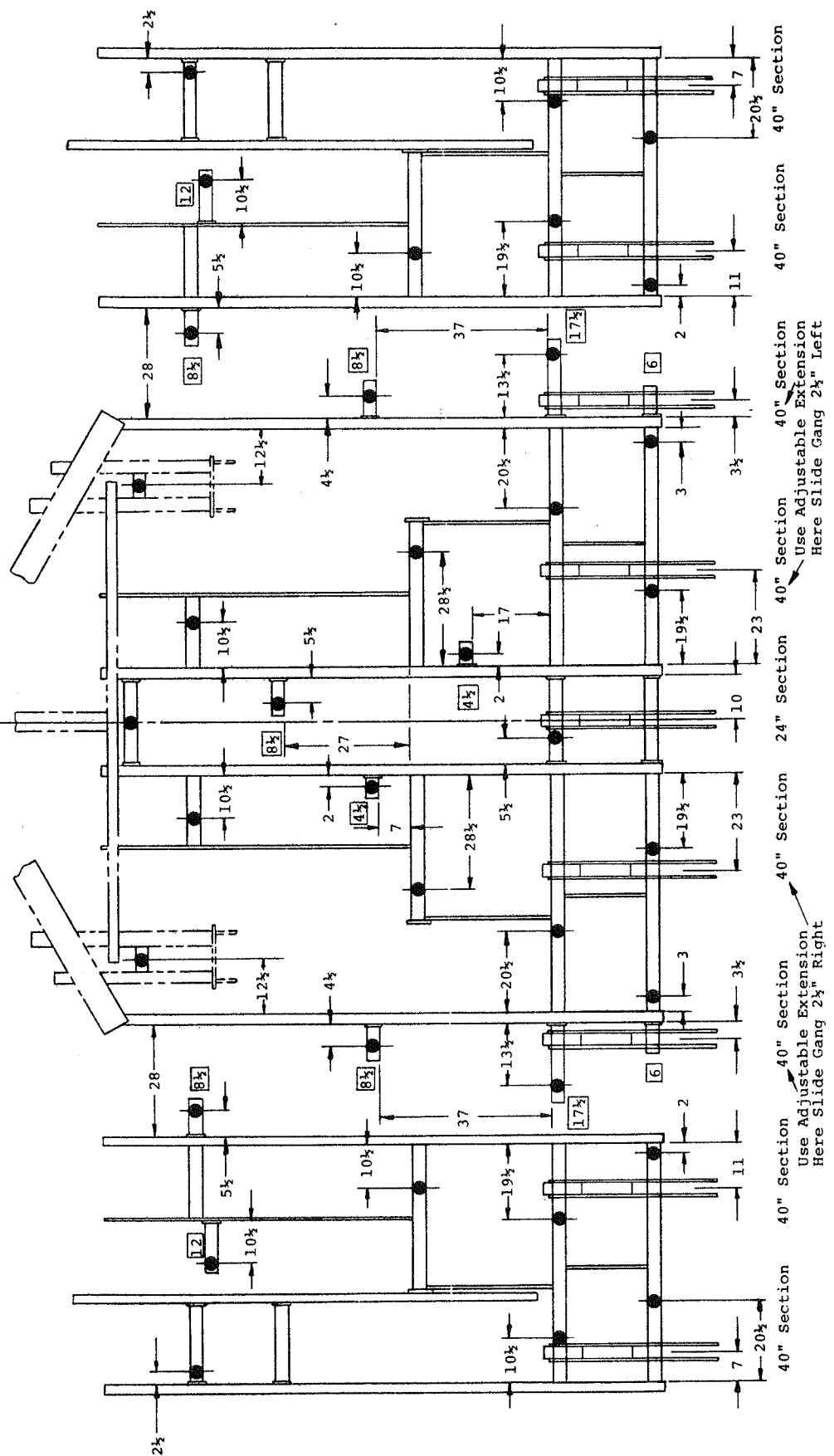

SGR-27-1
 Recommended Set Up Locations
 6" Field Cultivator Shank Spacing
 27' Working Width
 2 Gang Roller Harrows On Rear
 8½' Extension Length
 ● Shank Location
 31 Shanks Center 12 Shanks each Wing

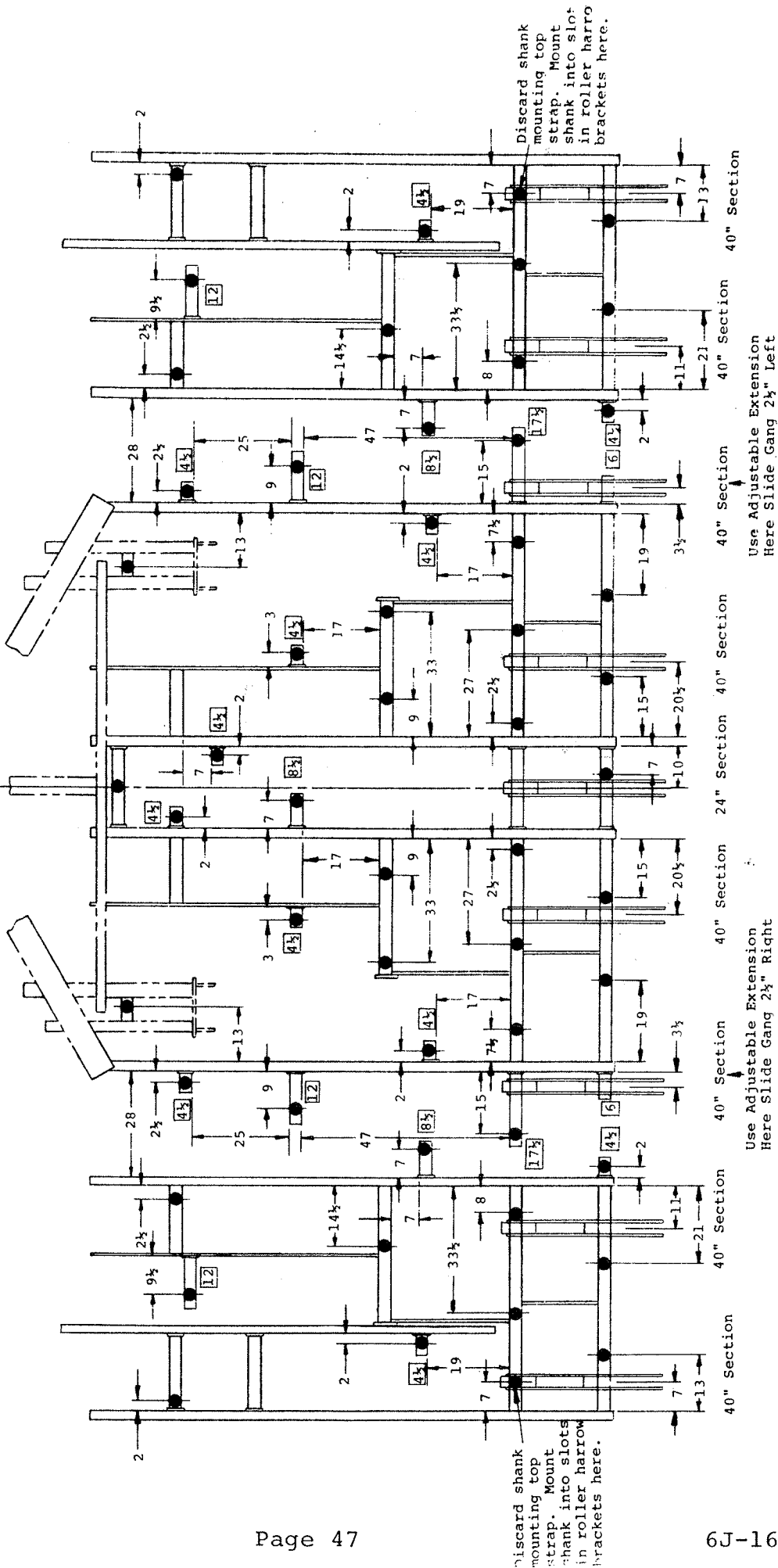

SGR-30-1

- Recommended Set Up Locations
- 6" Field Cultivator Shank Spacing
- 30" Working Width
- 2 Gang Roller Harrows on Rear

8 1/2 Extension Length
 Shank Location

31 Shanks Center 15 Shanks each Wing

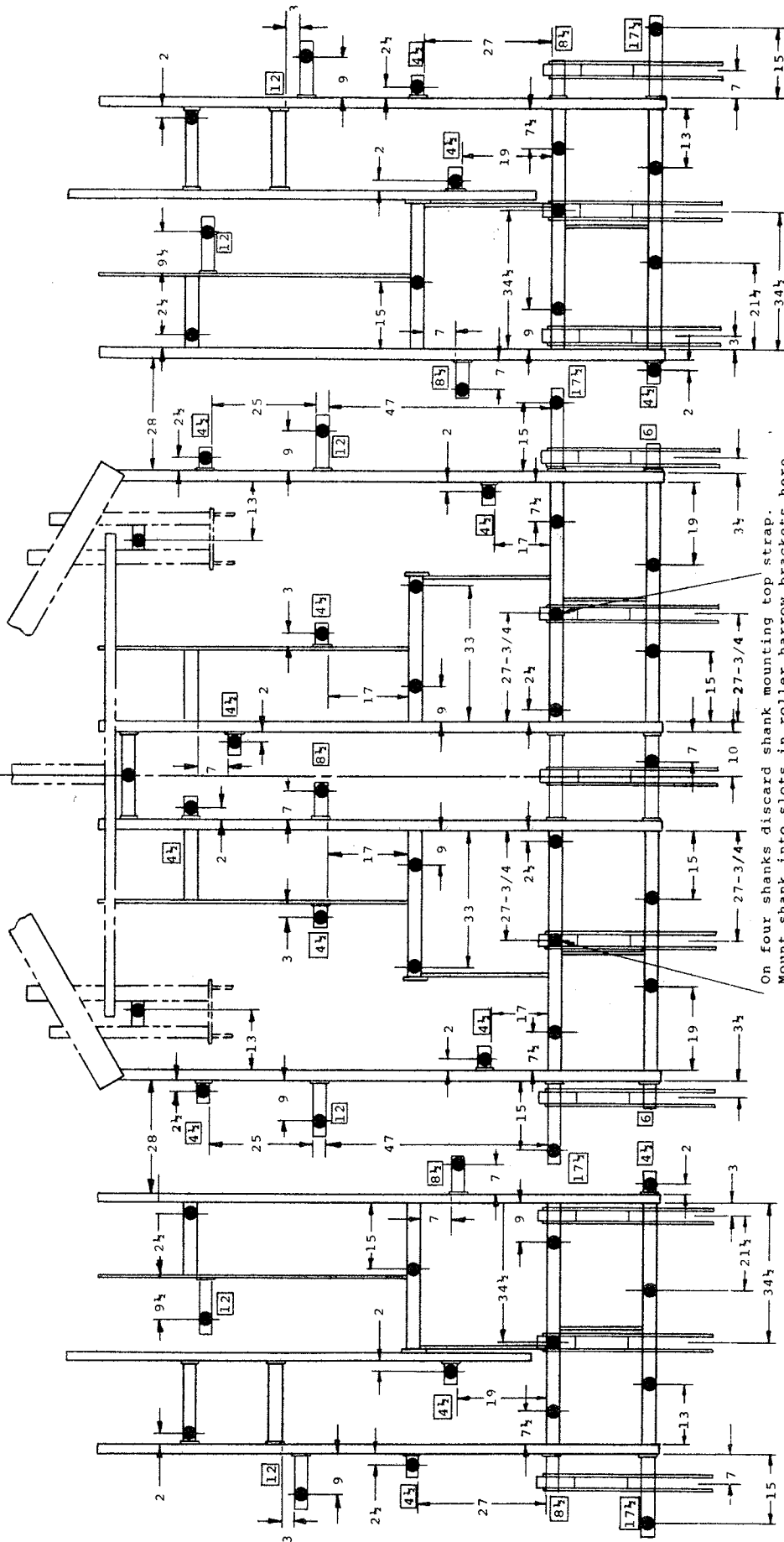

On four shanks discard shank mounting top strap.
Mount shank into slots in roller harrow brackets here.

40" Section 24" Section 40" Section 40" Section 24" Section 40" Section 24" Section 40" Section
 Use Adjustable Extension Use Adjustable Extension
 Here Slide Gang 2 1/2" Right Here Slide Gang 2 1/2" Left

When the drag bars are installed, the drawbar of the unit will become light when raised into transport position. To avoid possible injury and to attach the drawbar to the tractor, mount the included jack in a convenient location on the rear toothbar. With the machine in transport position, screw the jack down until it nearly touches the ground. Continue to screw the jack down to disconnect the machine from the tractor.

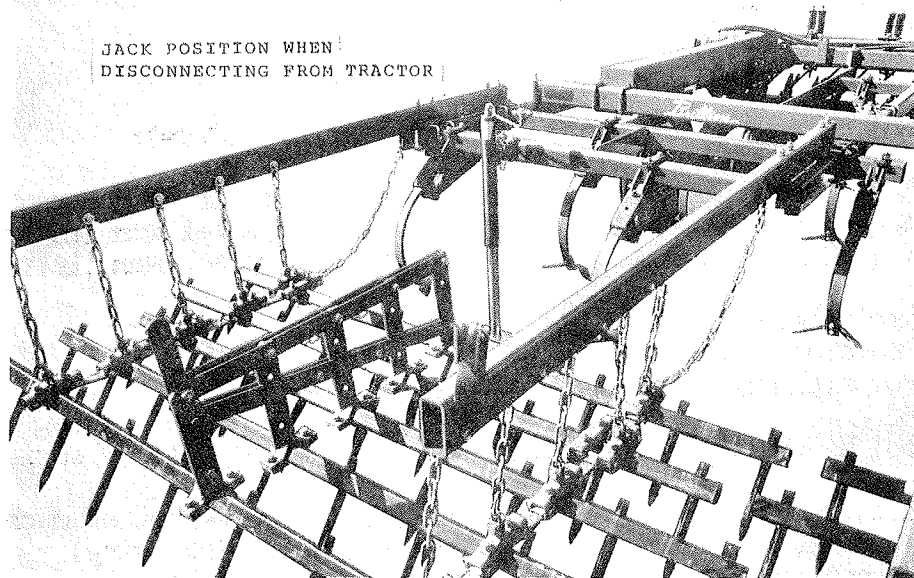
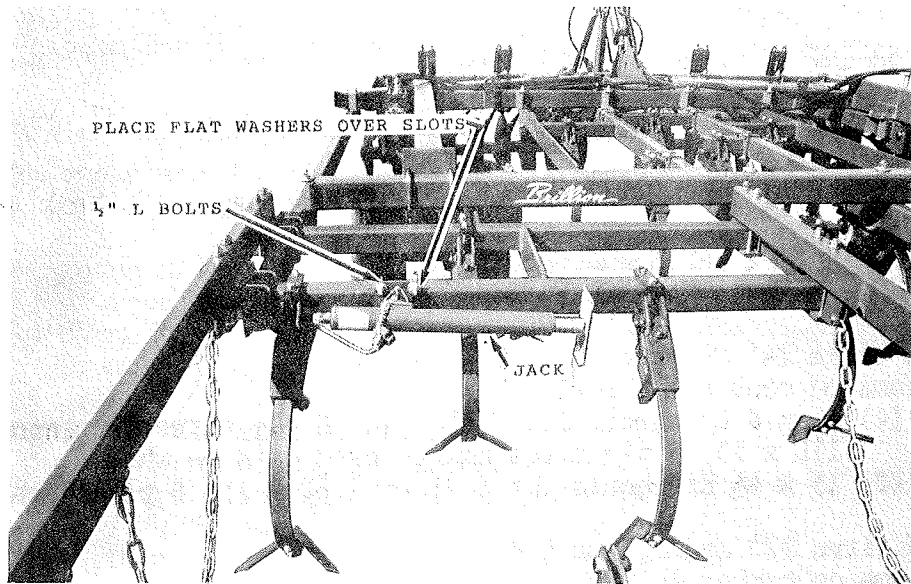

SPECIFICATIONS
(Subject to Change Without Notice)

The name plates are stamped "SC".
Model identification is as follows:

SGS = Soil Groomer, Field Cultivator Shanks
Spike Tooth Harrow Sections On Rear
SGR = Soil Groomer, Field Cultivator Shanks
Two Gang Roller Harrow On Rear

Working width is indicated with the next two digits representing working width of shanks in feet.

SG -24	24 Foot Working Width
SG -27	27 Foot Working Width
SG -30	30 Foot Working Width

If a third digit -1 appears at the end, this represents 6" shank spacing.

SG - - -1	6" Shank Spacing
SG - - -	9" Shank Spacing

Wheels and tires 24' machine only.

Walking beams on center section.

- (4) 15 x 8 LB wheels for 9.5L x 15 8 ply tires recommended
11L x 15 8 ply tires may be used on same wheels.
- (2) 15 x 4½ KB wheels for 6.70 or 7.60 x 15 6 ply tires on wings.

Wheels and tires 27' and 30' machines only.

Walking beams on center section.

- (4) 15 x 8 LB wheels for 11L x 15 10 ply tires.
- (2) 15 x 8 LB wheels for 9.5L x 15 6 ply tires on wings.

Wheel tread dimensions:

Inner wheels of walking beams: 6'10"
Outer wheels of walking beams: 10'5"
Wing wheels 24' only: 19'5"
Wing wheels 27' and 30': 25'2"

Depth control hydraulics 24' only (three series cylinders):

5" x 8" hydraulic depth stop rephasing master (front center of machine)
4-¾" x 8" rephasing slave connected to wheel arm (right side center)
4-½" x 8" rephasing slave connected to wheel arm (left side center)

Machine is self leveling.

Wing depth control: Ratchet jack.

Depth control with wing gage wheel.

Depth control hydraulics with wing gage wheels 24' only (five series cyl.)

5" x 8" hydraulic depth stop rephasing master (front center of machine)
3-¾" x 8" rephasing slave connected to wheel arm (right wing)
4-¾" x 8" rephasing slave connected to wheel arm (right side center)
4-½" x 8" rephasing slave connected to wheel arm (left side center)
4" x 8" rephasing slave connected to wheel arm (left wing)

Depth control hydraulics 27' & 30' models (five series cylinders):

- 5" x 8" hydraulic depth stop rephasing master (front center of machine)
- 4-3/4" x 8" rephasing slave connected to wheel arm (right wing)
- 4-1/2" x 8" rephasing slave connected to wheel arm (right side center)
- 4" x 8" rephasing slave connected to wheel arm (left side center)
- 3-3/4" x 8" rephasing slave connected to wheel arm (left wing)

Machine is self leveling.

Wing folding hydraulics 24': two 3-1/2" x 16" cylinders

Wing folding hydraulics 27' and 30': four 3-1/2" x 16" cylinders

24' and 27' models fold flat, 30' models fold 20° short of flat.

Drawbar: one piece ductile iron flip-flop hitch (clevis one end single lug opposite end)
1-1/2" diameter holes.
ratchet jack top link for leveling front to rear (for different tractor drawbar heights).
Jack stand is standard.
Drawbar length: 75"

Disk Gangs: 20" diameter discs, 2" concavity on 7-1/2" centers
16" end discs, 18" second disc
Triple lip sealed self aligning bearings
1-1/2" square axles
Discs have adjustable spring protection.
5" gang depth adjustment, 2" under to 3" above sweeps.
Adjustable rigid scrapers standard on all discs.

Field Cultivator Shanks: 21-3/4" under the mounting tube clearance.
Each shank is spring protected.
1/2" x 1-3/4" shanks
Maximum working depth 6-1/2"
Working width of field cultivator shanks are approximately (16" for 24'), (7" for 27') and (13" for 30') more than disc working width.

One of two finishing tools on rear as part of Soil Groomer:

Spike Tooth Drag (no tools required to make adjustments)
5 ranks of 2" spacing, 3/4" square x 12" long hardened spikes
2" square x 3/16" wall tube spike holders
5 angle positions for spikes
1 draft chain height position
Draft chains and support chains can be lengthened or shortened.
Each bar can flex independently of each of the other bars.
Working width of spike tooth drag sections (32" for 24'), (36" for 27') and (20" for 30') more than field cultivator shanks working width.

Two Gang Roller Harrows

- Two spiral type baskets
- 1/4" x 1" abrasion - resistant steel blades
- 10-1/4" outside diameter
- Each section has adjustable spring downward pressure
- Each section can move up and down freely
- Front basket can be set lower or higher than rear.
- Pin on each section for raising section partially or completely out of ground.

Overall length of all models is approximately 27'
 Transport road clearance: 11"
 When incorporating chemicals 7" sweeps are recommended for 6" spacing,
 10" sweeps for 9" spacing.

Optional Equipment:

- Spray shields (mount behind discs)
- 1-3/4" x 11" reversible points
- 2" heavy duty reversible points
- 4", 7", 9" and 10" full sweeps
- 2" reversible point or 4" full sweep on center shank

Speed and power requirements: 5 to 7 mph is recommended.
 Drawbar power required 6 to 10 H.P. per foot of width.

Model	Transport Width	Approx. Weight	Model	Transport Width	Approx. Weight
SGS-24	15'4"	10,135#	SGR-24	16'3"	10,255#
SGS-27	15'4"	11,055#	SGR-27	16'3"	11,086#
SGS-30	15'10"	12,260#	SGR-30	17'3"	12,400#
SGS-24-1	15'4"	10,502#	SGR-24-1	16'3"	10,622#
SGS-27-1	15'4"	11,595#	SGR-27-1	16'3"	11,626#
SGS-30-1	15'10"	12,800#	SGR-30-1	17'3"	12,940#
SGSH-24	15'4"	10,210#	SGRH-24	16'3"	10,330#
SGSH-24-1	15'4"	10,577#	SGRH-24-1	16'3"	10,697#

Transport Height 24' and 27' Models: 6'9"
 Transport Height 30' Models: 9'6"