

REPAIR PARTS CATALOG OPERATOR'S MANUAL

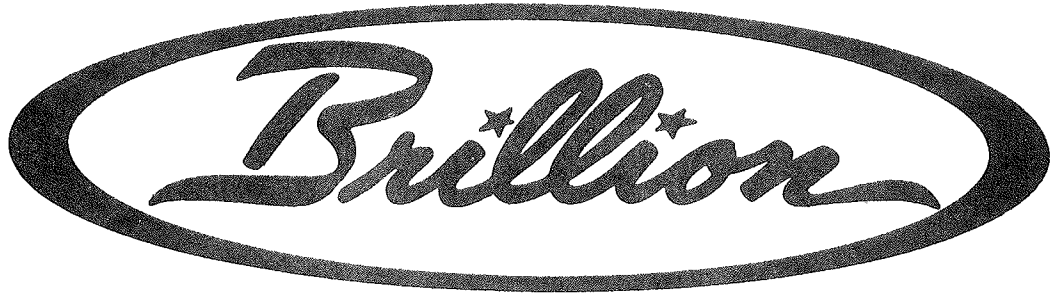

RO-CROP CULTIVATOR END TRANSPORT

FOR MODELS

BRS-640, BRS-830, BRS-840

1076



BRILLION IRON WORKS
BRILLION, WISCONSIN 54110
DIVISION OF BEATRICE FOODS



2J-211

Installation

The first step in the installation of your transport kit involves welding two angles (provided in box assembly) to the end of your cultivator frame tube. Do this as shown in the illustration on page 6.

Slide hitch tube about 3/4 of the way into toolbar. Install end bracket from top, sliding it over hitch tube. Bolt in place with four 5/8 bolts. Hold end bracket up when tightening bolts. Make sure that hitch tube is free to slide all the way in and out.

Install the pivot shaft from the top into the pivot tube on the end of the hitch tube. Slide collar up over the pivot shaft and secure with clinch pin. Set transport drawbar into pivot clevis and secure with pivot bolt, 3/4 x 6 drilled, and locknut. The drilled end of the pivot bolt must extend toward the rear and through the hole at the top of the end bracket. Use a hairpin cotter to hold the hitch in the telescoped position. This is position that the hitch should be in when operating in field.

Slide the support stand up from bottom into the square tubular part of the end bracket. For transport and for field operation, raise the support stand until the lower hole in the stand is above the square tube. Install clevis pin and secure with hairpin cotter.

Lay cross tube on top of frame tube in space between gangs. Locate cross tube in last space or next to last space on end opposite hitch extension tube. The short end of the cross tube is on the side where the cultivator hitch is located. Use the loose clamp and four 3/4" capscrews to secure cross tube to frame tube.

Pin wheel arms to the ends of the cross tube. The wheel arms are attached to the outer square tube on top of the cross tube and the square tube under the cross tube. Use 1" diameter pins to attach wheel arms. Hubs and spindles should point out when arms are down in transport position. Use two roll pins to secure the inner 1" pin and one roll pin and one Klik pin to secure the outer pin.

Good used automotive tires may be mounted on rims and inflated to 28-30 psi. Mount wheels to hubs with lug bolts provided.

Transport

It is the responsibility of the operator/owner to abide by all pertinent regulations regarding movement of wide agricultural equipment on public roads.

To make cultivator ready for end transport, raise cultivator to maximum height with tractor three point hitch. Swing transport wheels down and lock into place. Lower support stand to ground and secure with clevis pin under the square tube. Remove hairpin cotter from pivot bolt, slide hitch tube out until pivot bolt is clear and reinstall hairpin cotter in pivot bolt. Remove clinch pin from pivot shaft, remove and reinstall pivot shaft and transport drawbar from below hitch tube. Secure with collar and clinch pin. Pull hitch all the way out until lugs on side of bars engage end bracket angles.

Continued on page 6

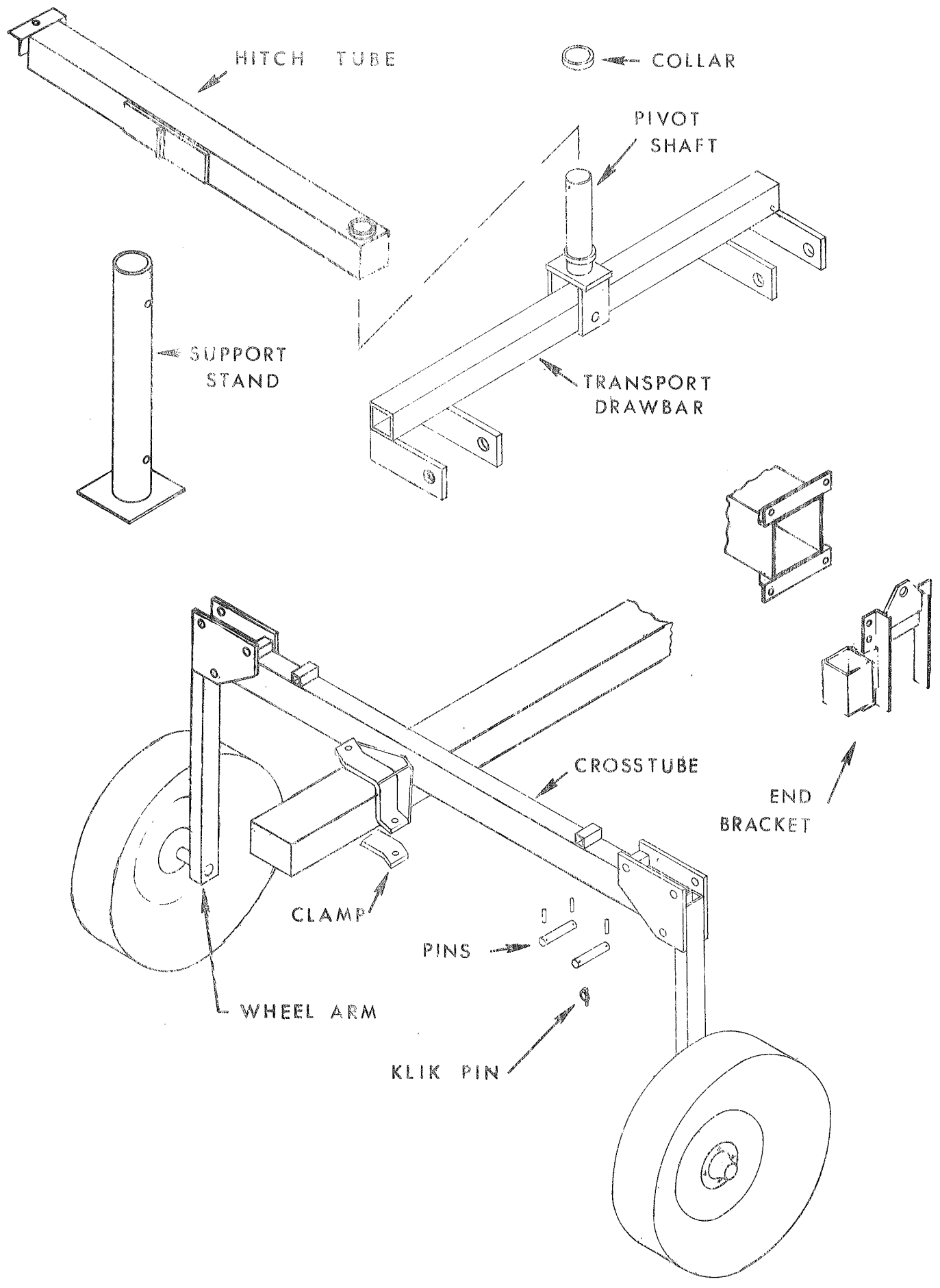

END TRANSPORT FOR RO-CROP CULTIVATOR

Index No.	Part No.	Part Name	No. Used	Weight
1	9D-93	Cross Tube Assembly	1	135.0
2	1J-549	Axle Arm Assembly W/Hub	2	60.3
3	9D-109	Pin	4	1.2
4	5D-110	Klik Pin	2	
5	4C-858	Roll Pin, 5/16 x 2	6	
6	9D-427	Clamp, 5 x 7 toolbar	2	7.5
	6D-741	Capscrew, 3/4-10 x 4 lg., Gr. 5 5 x 7 bar	2	
	3D-510	Capscrew, 3/4-10 x 2-1/2 lg., Gr. 5 5 x 7 bar	2	
	6C-729	Locknut, 3/4-10	4	
7	1D-273	Seal, BR248-140-4	2	.1
8	5C-480	Cone, LM48548	2	.2
9	5C-479	Cup, LM48510	2	.2
10	1J-390	Hub	2	6.3
11	5C-912	Cup, LM11910	2	.2
12	5C-911	Cone, LM11949	2	.2
13	3C-173	Slotted Nut, 3/4-16	2	
14	3C-350	Cotter Pin, 5/32 x 1	2	
15	4C-129	Wheel, 15" 5 bolt	2	15.0
16	1J-463	Hub Cap	2	
17	5C-100	Wheel Bolt	10	
18	9D-107	Collar	1	.25
	2J-217	Clinch Pin 2"	1	
19	1J-22	Hitch Tube Assembly	1	62.7
	8C-65	Capscrew, 5/8-11 x 3, Grade 5	1	
	5C-461	Locknut, 5/8-11	2	
20	9D-102	Pivot Shaft Assembly	1	17.5
21	9D-89	Hitch Bar Weldment	1	46.8
	1J-30	Pivot Bolt, 3/4-10 x 6, Grade 5, Drilled	1	
	1D-594	Hairpin Cotter .178 x 3-9/16	1	
	6C-729	Locknut, 3/4-10	1	
22	9D-87	Stand Weldment	1	24.3
	8D-382	Clevis Pin, 1/2 x 4	1	
	6C-400	Hairpin Cotter .0915 x 1-7/8	1	
23	1J-16	End Bracket	1	17.5
	4D-561	Capscrew, 5/8-11 x 1-1/2, Grade 5	4	
	1B-166	Lockwasher, 5/8 Med.	4	
	5C-461	Locknut, 5/8-11	4	

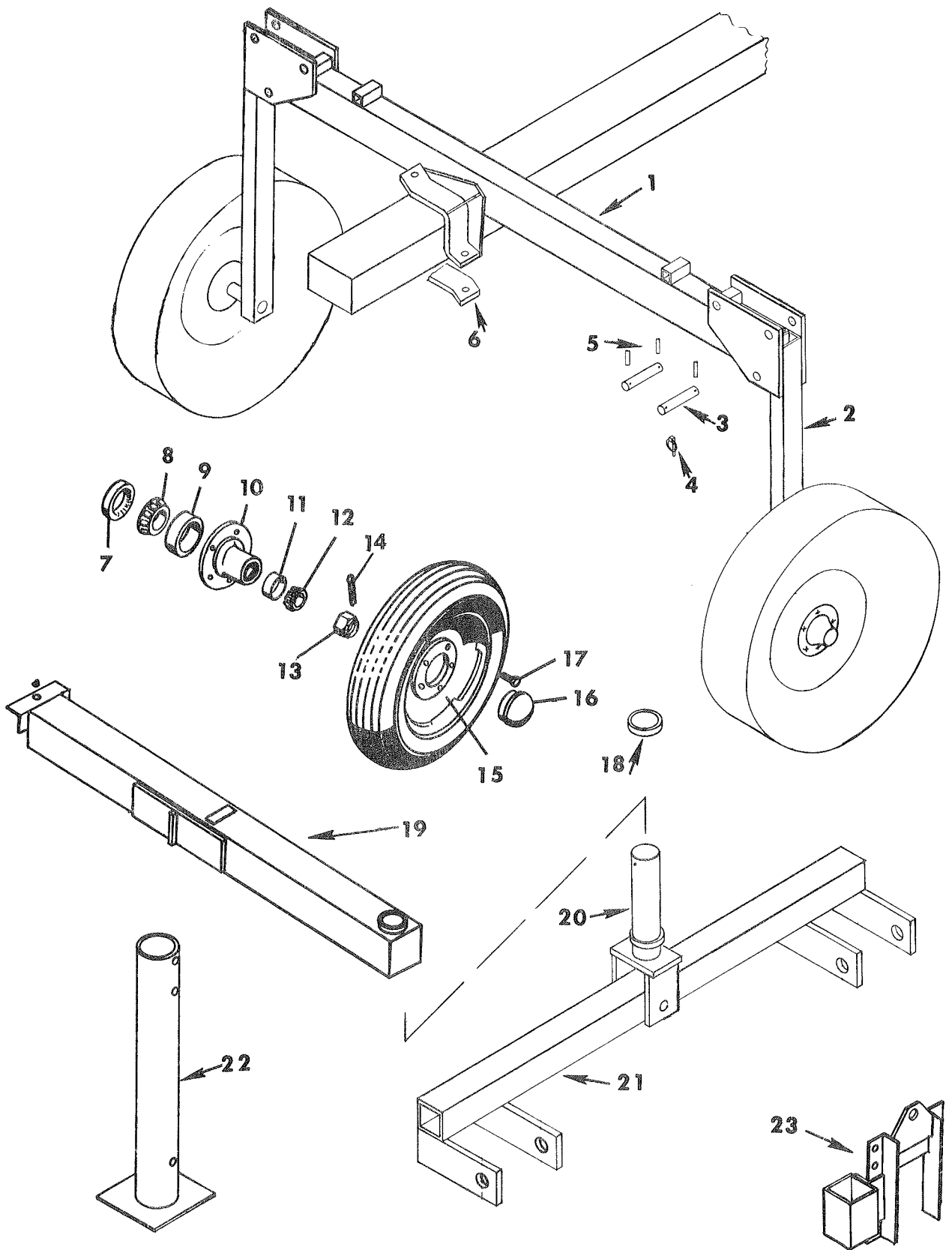

Lower three point hitch until cultivator stands on wheels and stand. Unhitch tractor from field hitch and re hitch tractor to transport drawbar. Use lower hitch pins and spacers from field hitch for attaching tractor to transport drawbar. Raise end of cultivator with three point lift and raise support stand and secure in up position.

Reverse this procedure for changing from transport to field position.

Weld full length, this edge of both angles to frame tube.

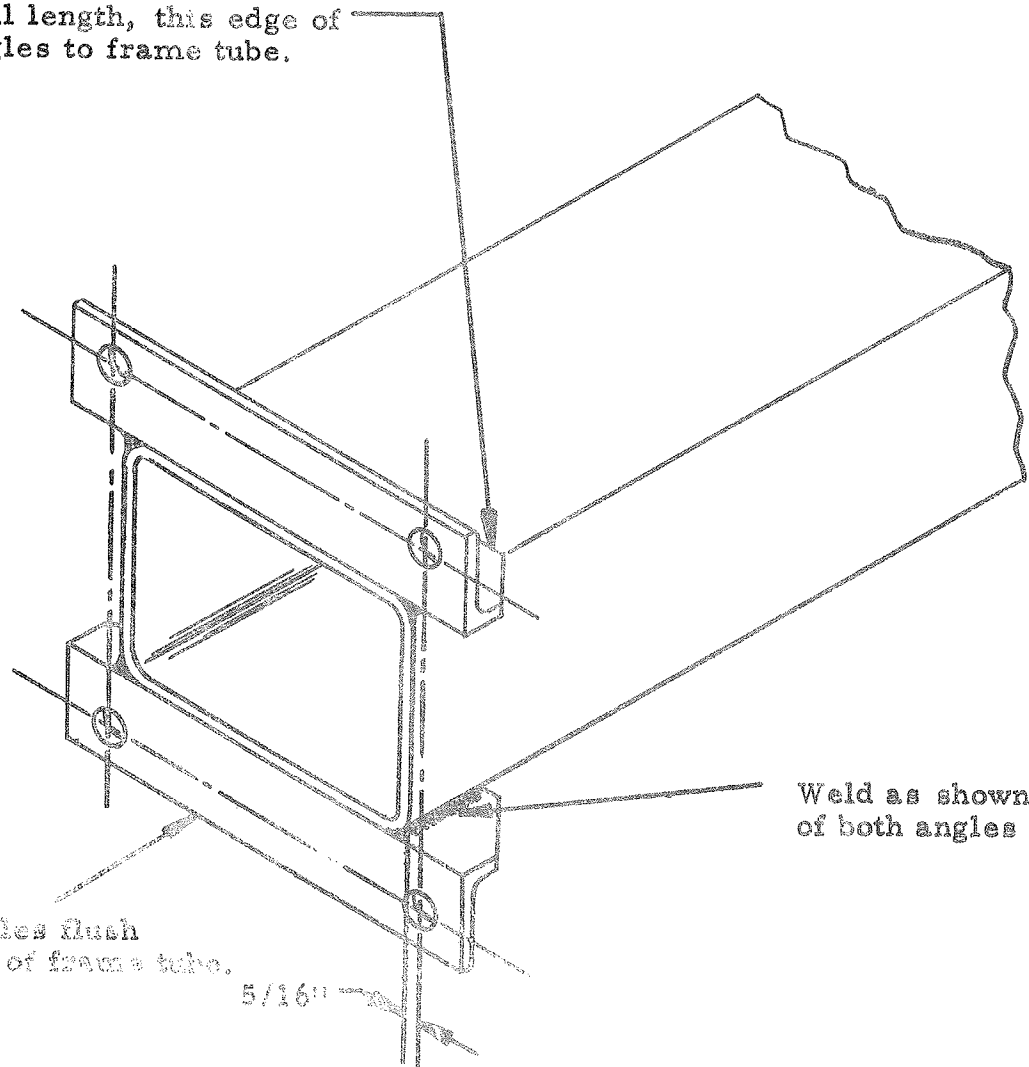

Weld as shown... both ends of both angles to frame tube.

Note angles flush with end of frame tube.

5/16"