

# OPERATOR'S MANUAL

*Brillion*

72" ROTARY SHREDDERS

MODELS RSS-72 & RSSP-72

*RSS-72-05 & RSSP-72-05*

BRILLION IRON WORKS, INC.

Brillion, Wisconsin, U. S. A.

~~169~~  
1076

9C-544

## GENERAL INFORMATION

RSS-72 Drawbar Type RSSP-72 Pickup Type

Swinging Blade Rotary Shredder

Your Brillion 72" Rotary Shredder is built with the best materials and workmanship available. All machines are adjusted at the factory to assure proper mechanical operation. The gear box is protected by two 3/8" shear pins in the P.T.O. shaft assembly.

You can avoid future difficulties by following the operating and maintenance instructions and by correctly adjusting and lubricating the machine when necessary.

\* \* \* \* \*

## LOCATION REFERENCE

"Right" and "Left", "Front" and "Rear", refer to the operator's "Right" and "Left", "Front" and "Rear", when he faces the same direction as the machine is traveling.

SPECIFICATIONS

Width of Cut - - - - -	72"
Height of Cut - - - - -	1" - 14"
Blades - - - - -	Heat treated alloy steel
Hood - - - - -	Heavy gauge steel-welded assembly
Gears - - - - -	Forged alloy steel - heat treated
Blade Drive - - - - -	Timken bearing equipped - all moving parts run in oil bath. Bearings are nut adjusted.
Blade Mounting - - - - -	Blades pivot on hardened alloy steel shoulder bolts.
P. T. O. Drive Shaft - - - - -	Heavy duty - 2 joint telescoping needle bearing assembly, with shear yoke and flange.
Hitch - - - - -	Adjustable to drawbar height of tractor and for leveling unit.
Lift (Drawbar Type) - - - - -	Tractor hydraulic cylinder or "Brillion" ratchet screw jack (order 7C-841 jack assembly).
Wheels (Drawbar Type) - - - - -	6.70 x 15 steel rim. Timken bearing wheel hubs.
Weight - - - - -	1000#

## ASSEMBLY INSTRUCTIONS

### RSS-72 Drawbar Type Shredder

To begin assembly, attach the drawbar to the top of the hood, using the bolts found in the drawbar angles. Now the axle arms can be bolted to the plates at the end of the axle shaft. The wheels can be arranged, so as to have the wheels mounted either forward or toward the rear. The latter is usually preferred when the machine is to be used close to fences or under trees. With the wheels rear mounted, the machine is drawbar heavy. With the wheels side mounted the shredder will be about in balance. The tractor hydraulic lift cylinder or "Brillion" ratchet screw jack should be installed in the cylinder mounting lug and in the TOP hole of the axle lift arm. This is true when the wheels are mounted to the side or rear of the machine.

### RSSP-72 Pickup Type Shredder

To begin assembly, detach the braces from the tailwheel assembly, and bolt the frame to the top of the shredder hood. All bolts are found in their respective holes. With the frame in place, attach the braces to the lower hole in the upper hitch point on the frame mast and the hood top beside the gearbox.

The tailwheel assembly is shipped complete, and is installed in the four holes toward the rear of the hood top. Adjustment is made by removing the crossbolt at the rear, and sliding the arm up and down in its bracket.

The P.T.O. shaft should then be attached to the gearbox. Place the involute splined shear hub onto the shaft, and align the 5/16" diameter hole in the shaft and hub. Place the 5/16" diameter bolt through the hub and shaft and draw nut up tight.

**BEFORE OPERATING THE MACHINE, REMOVE THE PIPE PLUG IN THE GEAR HOUSING COVER AND FILL TO OIL LEVEL. The oil level mark is indicated on the cover.**

## OPERATION

General These shredders are intended for operation at a P. T. Q. speed of 536 R. P. M. Running your tractor at part throttle will result in less satisfactory shredding. Control your ground speed with your gearshift, and maintain shredder at rated speed.

When starting a swinging-blade shredder, the blades are usually not in balance at first, and the machine will shake violently if started too quickly. Engage the PTO slowly at a low throttle setting. The blades will balance quickly and you may increase speed. Try to avoid starting the machine directly in heavy work. Give the blades a chance to balance first.

These machines are rated for general service in mowing and grass cutting, shredding prunings, cornstalks, straw, etc. and brush up to approximately 1" in diameter.

When using, set the cutting height so as to avoid rocks, wire, etc. and keep blades out of the ground. Short life of the blade edge almost always means abrasive or rocky conditions have been encountered.

### Maintenance

These shredders are designed to require simple lubrication procedures. The only zerk fittings are in the P.T.O. shaft. The only oil check is in the gearbox, where the level is indicated. Check oil monthly. When adding or changing oil, use SAE 140 in summer, SAE 90 in winter.

Should it become necessary to replace broken shear bolts, use 3/8" x 2-1/4 or 2-1/2" long square head machine bolts. These bolts are readily obtainable from equipment dealers or hardware stores. When replacing these bolts draw up on the hexagon nuts until shear flanges meet. Do not clamp flanges tight!

It is advisable each year, before using the shredder, to go over all bolts for tightness. In addition, it is especially important to check the blade pivot bolts regularly. The blades should swing freely, but with very little slack in any direction. When necessary, replace these parts only with genuine Brillion parts.

### Slip Clutch

The multiple disc clutch is intended to protect the shredder and tractor against shock and overload damage. It also eliminates the downtime created by replacing shear pins. If the clutch runs hot during normal operation of the tractor, draw up 1/6 turn on each of the (12) adjusting screws. Continue to operate and recheck for heating. Do this until excessive slippage and heating are eliminated.

Periodic adjustment will be necessary to compensate for wear on the clutch facings.

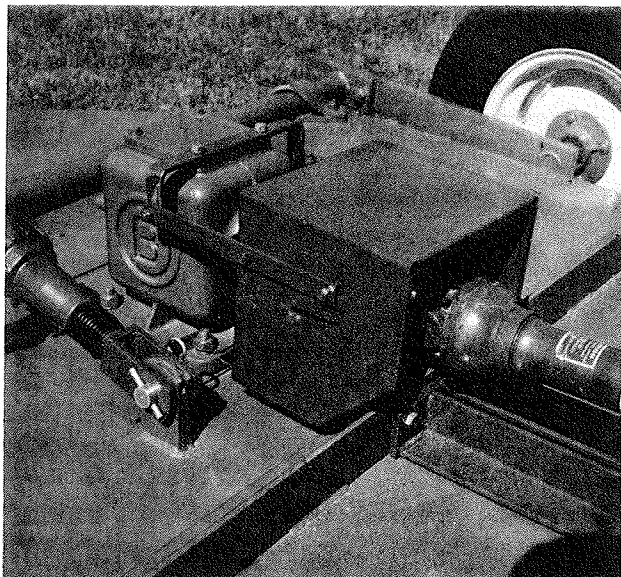

Assemble P. T. O. shield to the gearbox as shown in photo at left. Longer cap screws are provided.

Keep this shield in place while operating. Before lifting the shield for servicing or adjusting, make sure all movement has stopped.

9C-544  
6D-837

INSTRUCTIONS FOR REMOVING  
QUICK DETACHABLE FREE WHEELING GUARD

1. Use screw driver or sharp pointed tool to remove snap ring from groove at back of bell.

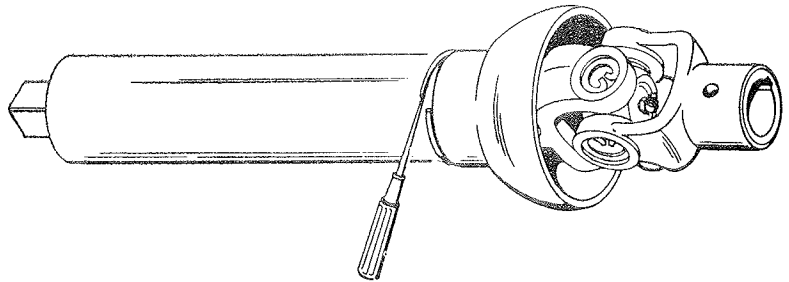

2. Hold assembly over container so that balls will not be lost and slide bell away from joint toward opposite end of tube. If balls do not drop out, slide tube away from joint, forcing balls from cage.

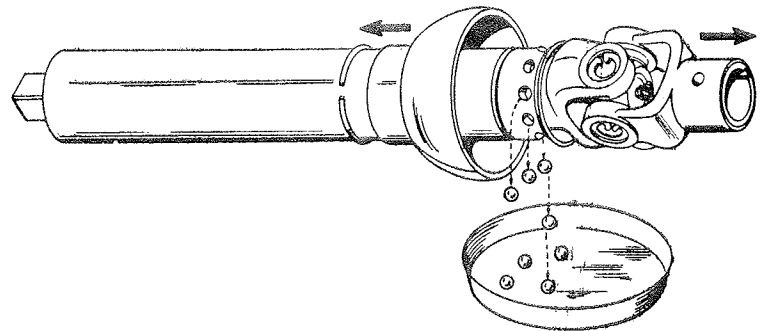

INSTRUCTIONS FOR ASSEMBLING  
QUICK DETACHABLE FREE WHEELING GUARD

3. Fill raceway in yoke with grease.

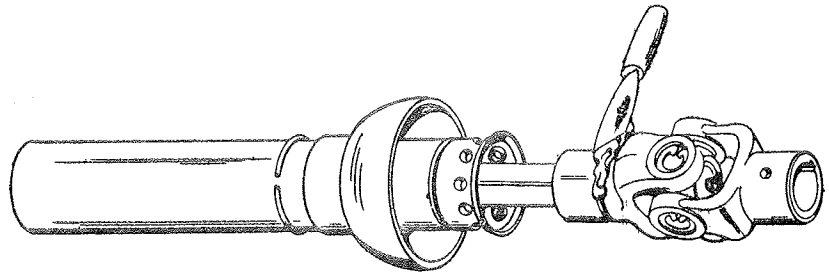

4. Slide tube with bell and snap ring over raceway. Insert balls through holes into raceway where grease will hold them in place. Slide bell over balls. Slide snap ring into groove.

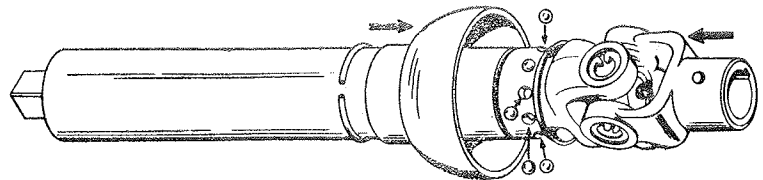

Grease joints, telescoping shafts and guard regularly. This Quick Detachable Free Wheeling Guard is the finest guard built. It is provided for your protection.

Form 4D-200  
9C-544

9C-636  
1D-626  
8C-658

9C-494  
5C-103  
6C-727

## Instructions for Removing Nylon Quick Detachable Free Wheeling Guard

1. Insert screw driver in slot in bell and push snap ring downward and forward out of groove toward large opening of bell.

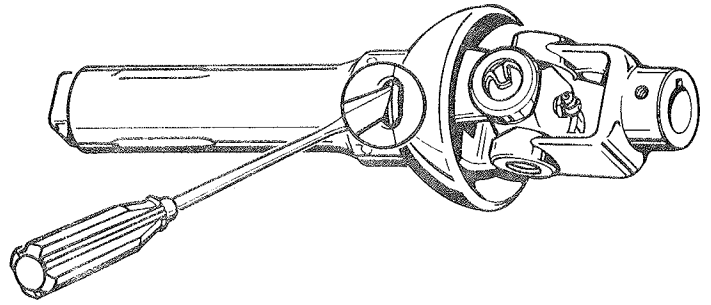

2. Slide guard off of joint.

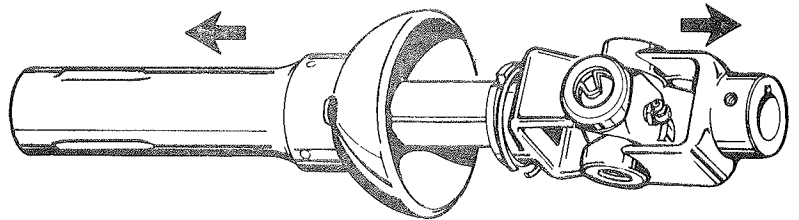

## Instructions for Assembling Nylon Quick Detachable Free Wheeling Guard

1. Slide snap ring over joint hub.

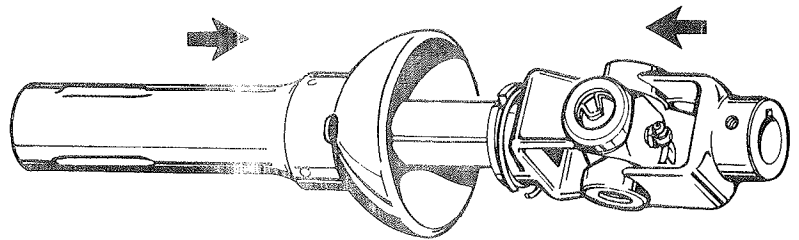

2. Insert nylon bearing in groove of joint hub.

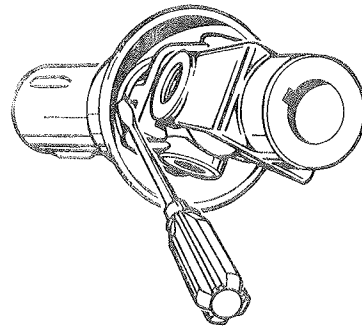

3. Slide joint assembly into guard. With screwdriver, push snap ring into groove.

**WARNING - DO NOT POUND BELL TO REMOVE JOINT ASSEMBLY.**

