

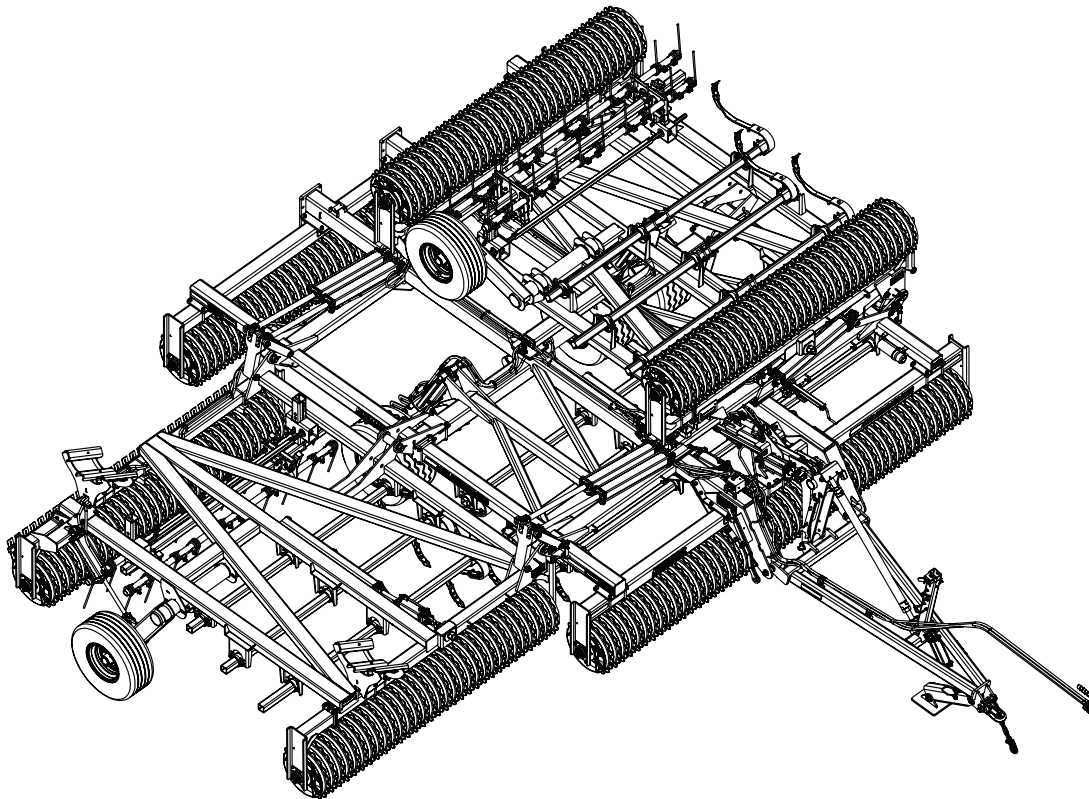

Pulvi-Mulcher 3631-36 Model Operator's Manual



LANDOLL COMPANY, LLC

1900 North Street

Marysville, Kansas 66508

(785) 562-5381

800-428-5655 ~ WWW.LANDOLL.COM

Manuals for 3631-36 Pulvi-Mulcher

Manual Number	Manual Type
F-1064	Operator's Manual
F-1063	Parts Manual

Table of Contents

1 Safety Information

Introduction	1-1
Description of Unit	1-1
Owner Assistance	1-1
Warranty Registration	1-1
Safety	1-2
Understanding Safety Statements	1-2
Transporting Safety	1-2
Safety Instructions for Towing Vehicles	1-3
Attaching, Detaching and Storage	1-3
Maintenance Safety	1-3
Protective Equipment	1-3
Tire Safety	1-3
Chemical Safety	1-3
Prepare for Emergencies	1-3
High Pressure Fluid Safety	1-4
Decals	1-5

2 Assembly

Frame Installation	2-1
Rockshaft Installation	2-6
Rockshaft Cylinder and Transport Lock Installation	2-7
Wheel Installation	2-8
Drawbar w/ Manual Jack Installation	2-10
Drawbar w/ Hydraulic Jack Installation	2-12
Drawbar Leveling Installation	2-14
Manual Holder and Wrenches Installation	2-16
Wing Fold Hydraulic Cylinder Installation	2-17
Tooth Control Center Frame Cylinder Installation	2-18
Hydraulics	2-18
Plumb Tooth Control Circuit	2-19
Plumb Fold Circuit	2-22
Plumb Lift Circuit	2-29
Purging the Hydraulic System	2-36
Purge the Lift Cylinders	2-36
Purge Fold Circuit	2-36
Center Frame Tooth Tube Installation	2-37
Center Frame Shank Mounting Dimensions	2-38

Center Frame Tooth Control Brackets Mounting Dimensions	2-39
Center Frame Tooth Control Installation	2-40
Shank Installation	2-42
Shank Depth Control Installation	2-44
Center Frame 2-Row Harrow Installation	2-47
LED Warning Lamp Installation	2-51
SMV Sign Installation	2-51
Bearing Hanger and Wing Rest Installation	2-54
Wing to Frame Installation	2-56
Left and Right Hand Wing Roller Installation	2-59
Wing Tooth Control Cylinder Installation	2-62
Wing Tooth Tube Installation	2-63
Wing Shank Mounting Dimensions	2-64
Wing Tooth Control Mounting Dimensions	2-66
Wing Tooth Control Installation	2-69
Plumb Wing Tooth Control Cylinders	2-72
Purging the Tooth Control Cylinders	2-72
Wing Shank Installation	2-73
Wing 2-Row Harrow Installation	2-74
Roller Clamp Spacer Installation	2-78
Center Rear Scraper Installation	2-80
Wing Rear Scraper Installation	2-82
Center Front Scrapers - Optional	2-84
Center Front Scraper Mounting Dimensions	2-85
Wing Front Scraper Installation - Optional	2-86
Wing Front Scraper Mounting Dimensions	2-87
Rear 3-Bar Coil Tine Harrow Without Lift Kit - Optional	2-88
Rear 3-Bar Coil Tine Harrow Without Lift Installation	2-89
Rear 3-Bar Coil Tine Harrow With Lift Kit - Optional	2-92
Rear 3-Bar Coil Tine Harrow With Lift Installation	2-93
Plumb 3-Bar Coil Tine Harrow With Lift	2-96
Purge Hydraulic Rear 3-Bar Coil Tine Harrow With Lift	2-96
Land Leveler Installation - Optional	2-99
Center V-Leveler Installation - Optional	2-102
Wing V-Leveler Installation	2-102
Rear Hitch Installation - Optional	2-104

3 Operation

Tractor Preparation	3-2
Pulvi-Mulcher Preparation	3-2
Attaching to the Tractor	3-2

Hydraulic Lift System	3-3
Hydraulic Fold System	3-3
Hydraulic Tooth Control	3-4
Shank Depth Control Adjustment	3-4
General Operation	3-6
Operation of Rockshaft Transport Lock	3-6
Manual Transport Lock Models	3-6
Hydraulic/Automatic Transport Lock Models	3-6
Drawbar Turnbuckle Adjustment	3-11
Coil Tine Harrow	3-12
Land Leveler/V-Leveler - Optional	3-13
Scraper Adjustment	3-14
Transport	3-15

4 Maintenance

General Torque Specifications	4-1
Hydraulic Fitting Torque Specifications	4-2
Fasteners	4-2
Tires	4-3
Wheel Hub Bearing Maintenance	4-3
Lubrication Maintenance	4-3
Hydraulic Maintenance	4-3
Roller Axle Assembly	4-5
Clamp Tightening	4-5
Clamp End Spacers - Optional	4-6
LED Warning Lamps	4-8
Storage	4-9

5 General Reference and Specifications

TABLE OF CONTENTS

Safety Information

Introduction

The implement described in this manual has been designed with care and built by skilled workers using quality materials and processes. Proper assembly and maintenance will provide you with satisfactory use for seasons to come.

DANGER

Read this entire manual before attempting to assemble, adjust or operate this implement. Failure to comply with this warning can result in personal injury or death, damage to the implement or its components and inferior operation.

Description of Unit

The **3631-36 Pulvi-Mulcher** features three rows of 2-piece Field Cultivator S-Tine Shanks for additional frame clearance and residue flow. 8" Roller Axles with 61mm bearings include 24" Roller Wheels. A 2-Bar Coil Tine Harrow located in front of the rear roller provides additional seedbed leveling. Active Hydraulic Wing Down Pressure ensures the wings follow the soil contour and distributes the weight uniformly across the width of the machine.

Using this Manual

This manual will familiarize you with safety, assembly, operation, adjustment, and maintenance. Read this manual and follow the recommendations to help ensure safe and efficient operation.

- The information in this manual is current at time of printing. Some parts may have changed to assure top performance.
- Location reference: Right and Left designations in this manual are determined by facing the direction the implement will travel during field operation, unless otherwise stated.

Owner Assistance

If customer service or repairs are needed, contact your Brillion dealer. They have trained personnel, parts and service equipment specially designed for Brillion products. Your implement's parts should only be replaced with Brillion parts. If items covered in this manual are not understood, contact your local Brillion Dealer.

Warranty Registration

Brillion Farm Equipment, by Landoll, shall have no warranty obligation unless each product is registered within 10 days of retail purchase, using the Landoll Company, LLC Ag Products on-line registration process. Please refer to the Ag Products Policy and Procedures Manual, accessible at www.landoll.com for step by step instructions regarding product registration.

Enter your product information below for quick reference. Refer to the ID Plate as shown. **See Figure 1-1.**

MODEL NUMBER _____

SERIAL NUMBER _____

DATE OF PURCHASE _____

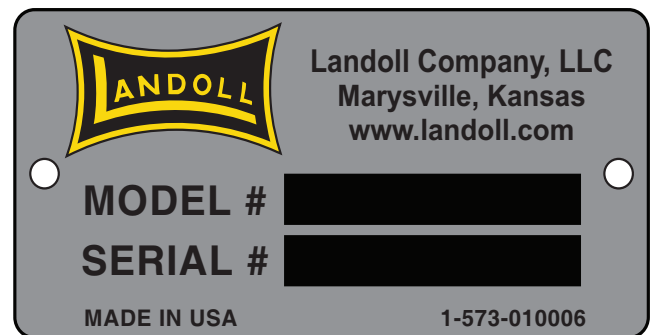

Figure 1-1: ID Plate

Safety

NOTE

Investigation has shown that nearly 1/3 of all farm accidents are caused by careless use of machinery. Insist that all people working with you or for you abide by all safety instructions.

Understanding Safety Statements

You will find various types of safety information on the following pages and on the implement decals (signs) attached to the implement. This section explains their meaning.

NOTICE

Special notice - read and thoroughly understand.

 **CAUTION**

Proceed with caution. Failure to heed caution may cause injury to person or damage product.

 **WARNING**

Proceed with caution. Failure to heed warning will cause injury to person or damage product.

 **DANGER**

Proceed with extreme caution. Failure to heed notice will cause injury or death to person and/or damage product.

NOTE

You should read and understand the information contained in this manual and on the implement decals before you attempt to operate or maintain this equipment.

- Examine safety decals and be sure you have the correct safety decals for the implement. **See Figure 1-3.**
- Order replacement decals through your Brillion dealer.
- Keep these signs clean so they can be observed readily. It is important to keep these decals cleaned more frequently than the implement. Wash with soap and water or a cleaning solution as required.
- Replace decals that become damaged or lost. Also, be sure that any new implement components

installed during repair include decals which are assigned to them by the manufacturer.

- When applying decals to the implement, be sure to clean the surface to remove any dirt or residue. Where possible, sign placement should protect the sign from abrasion, damage, or obstruction from mud, dirt, oil etc.

 **DANGER**

- **Do not allow anyone to ride on the tractor or implement. Riders could be struck by foreign objects or thrown from the implement.**
- **Never allow children to operate equipment.**
- **Keep bystanders away from implement during operation.**

Transporting Safety

IMPORTANT

It is the responsibility of the owner/operator to comply with all state and local laws.

- When transporting the implement on a road or highway, use adequate warning symbols, reflectors, lights and slow moving vehicle sign as required. Slow moving tractors and towed implements can create a hazard when driven on public roads. They are difficult to see, especially at night.
- Do not tow an implement that, when fully loaded, weighs more than 1.5 times the weight of the towing vehicle.
- Carry reflectors or flags to mark the tractor and implement in case of breakdown on the road.
- Do not transport at speeds over 20 MPH under good conditions. Never travel at a speed which does not allow adequate control of steering and stopping. Reduce speed if towed load is not equipped with brakes.
- Avoid sudden stops or turns because the weight of the implement may cause the operator to lose control of the tractor. Use a tractor heavier than the implement.
- Use caution when towing behind articulated steering tractors; fast or sharp turns may cause the implement to shift sideways.
- Keep clear of overhead power lines and other obstructions when transporting. Know the transport height and width of your implement. **See “General Reference and Specifications” on page 5-1.**

Safety Instructions for Towing Vehicles

The maximum travel speed is the lesser of

- The limit of the road conditions;
- The maximum specified ground speed;
 - for towing operations as indicated in this manual or SIS;
 - of the towed vehicle as indicated in its operator's manual, SIS, or information sign;
- The maximum ground speed of the towed equipment combination shall be limited to the lowest specified ground speed of any of the towed machines. This speed is the ground speed limitation.

EXAMPLE: If the tractor is capable of 25 mph, the first implement has a SIS for 19 mph, and the last implement's operator's manual states its specified ground speed is 15 mph, the towed equipment combination ground speed limitation is 15 mph.

Attaching, Detaching and Storage

- Do not stand between the tractor and implement when attaching or detaching implement unless both are blocked from moving.
- Before applying pressure to the hydraulic system, be sure all connections are tight and that hydraulic lines and hoses are not damaged.
- Block implement so it will not roll when unhitched from the tractor.
- Relieve pressure in hydraulic lines before uncoupling hydraulic hoses from tractor.

NOTE

To relieve hydraulic pressure: Depending on tractor hydraulic system, some can be relieved by actuating control lever after engine is stopped. If tractor has electric over hydraulic controls, it may be necessary to move the control lever to the float position. Refer to Tractor's Operator's Manual.

Wear protective gloves and safety glasses or goggles when working with hydraulic systems.

Maintenance Safety

- Block the implement so it will not roll when working on or under it to prevent injury.
- Transport Locks installed.
- Do not make adjustments or lubricate the machine while it is in motion.
- Make sure all moving parts have stopped.
- Understand the procedure before doing the work. Use proper tools and equipment.

Protective Equipment

- Wear protective clothing & equipment appropriate for the job. Avoid loose fitting clothing.
- Because prolonged exposure to loud noise can cause hearing impairment or hearing loss, wear suitable hearing protection, such as earmuffs or earplugs.

Tire Safety

Tire changing can be dangerous and should be performed by trained personnel using correct tools and equipment.

- When inflating tires, use a clip-on chuck and extension hose long enough to allow you to stand to one side, not in front of or over the tire assembly. Use a safety cage if available.
- When removing and installing wheels use wheel-handling equipment adequate for the weight involved.

Chemical Safety

Agricultural chemicals can be dangerous. Improper use can seriously injure persons, animals, plants, soil & property.

- Read chemical manufactures instructions and store or dispose of unused chemicals as specified. Handle chemicals with care & avoid inhaling smoke from any type of chemical fire.
- Store or dispose of unused chemicals as specified by the chemical manufacturer.

Prepare for Emergencies

- Keep a First Aid Kit and Fire Extinguisher handy
- Keep emergency numbers for doctor, ambulance, hospital and fire department near phone.

SAFETY INFORMATION

High Pressure Fluid Safety

Escaping fluid under pressure can be nearly invisible and have enough force to penetrate the skin causing serious injury. Use a piece of cardboard, rather than hands, to search for suspected leaks.

- Any fluid injected into the skin must be surgically removed within a few hours or gangrene may result.
- Avoid the hazard by relieving pressure before disconnecting hydraulic lines.

NOTE

To relieve hydraulic pressure: Depending on tractor hydraulic system, some can be relieved by actuating control lever after engine is stopped. If tractor has electric over hydraulic controls, it may be necessary to move the control lever to the float position. Refer to Tractor's Operator's Manual.

Wear protective gloves and safety glasses or goggles when working with hydraulic systems.

Safety Chain

Use the Safety Chain to help control drawn machinery should it separate from the tractor drawbar.

- Use a chain with a strength rating equal to or greater than the gross weight of towed machinery, in accordance with ASAE S338.2 specifications. If two or more machines are pulled in tandem, a larger chain may be required. Chain capacity must be greater than the total weight of all towed implements.
- A second chain should be used between each implement.
- Attach the chain to the tractor drawbar support or specified anchor location. Never attach the chain to an intermediate support. Allow only enough slack in the chain to permit turning. The distance from hitch pin to attachment point or intermediate support point should not exceed 9 inches. **See Figure 1-2.** If the distance from the drawbar pin to either the front or rear chain attachment point exceeds 9 inches, intermediate chain support is required. See Tractor Operator's Manual.
- Replace chain if any links or end fittings are broken, stretched or damaged.
- Do not use a Safety Chain for towing.

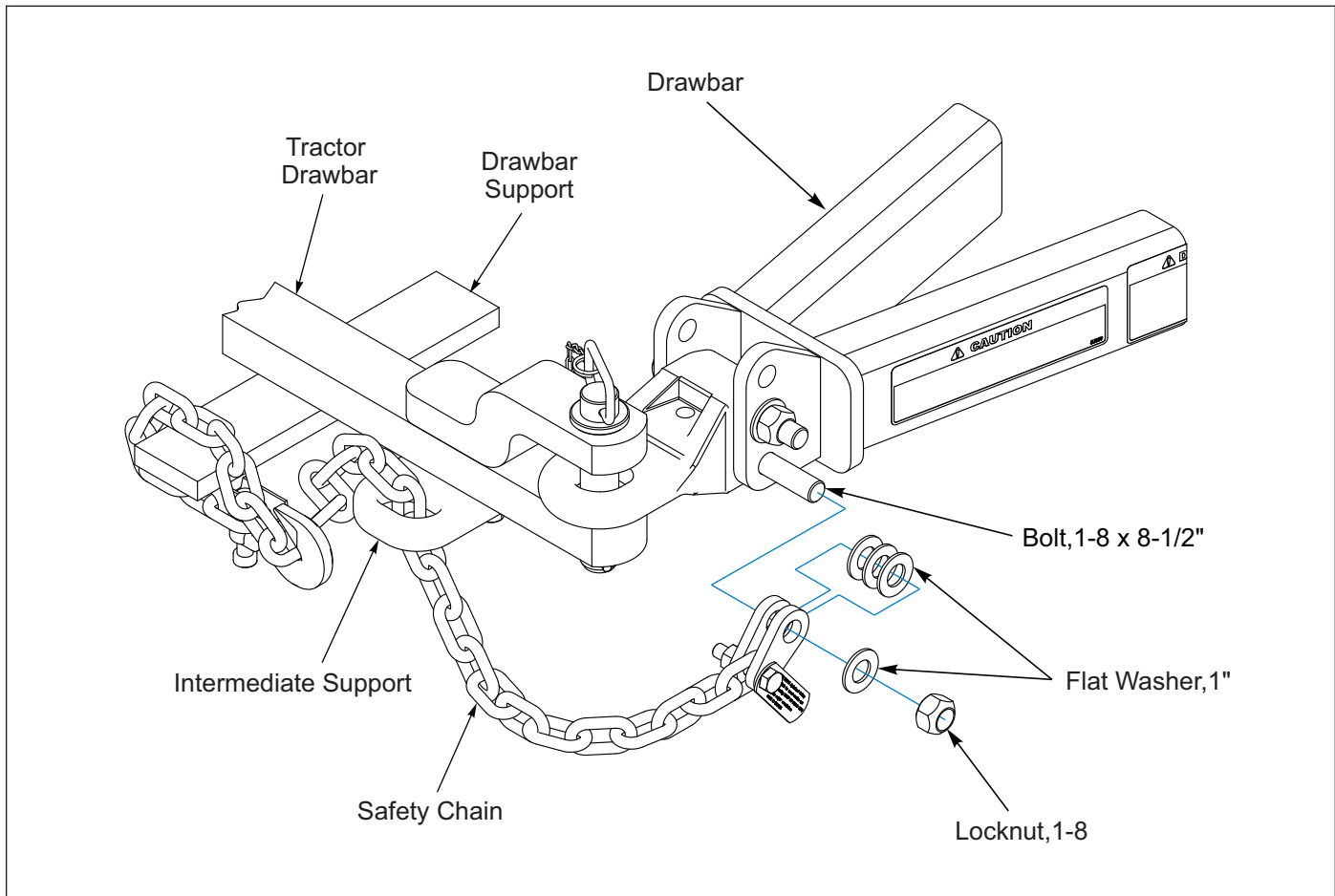
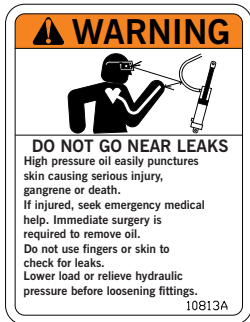
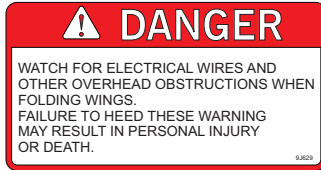

Figure 1-2: Safety Chain

Decals



ITEM 1
3K706



ITEM 2
9J629



ITEM 3
2-573-010037



ITEM 6
2-573-010198



ITEM 4
5J859

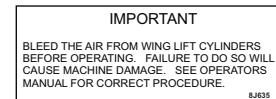

ITEM 16
8J635



ITEM 7
2-573-010335



ITEM 8
3J675

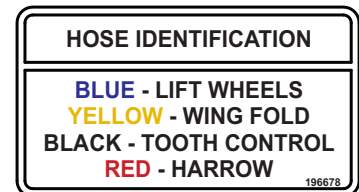

ITEM 5
196678



ITEM 14
144108



ITEM 10
528933



ITEM 11
528938



ITEM 12
528934



ITEM 13
170510



ITEM 9
214146



ITEM 15
2P151

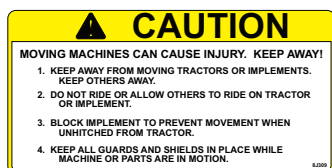

ITEM 17
8J309



ITEM 18
1-573-010006



ITEM 19
232191

Figure 1-3: Decals

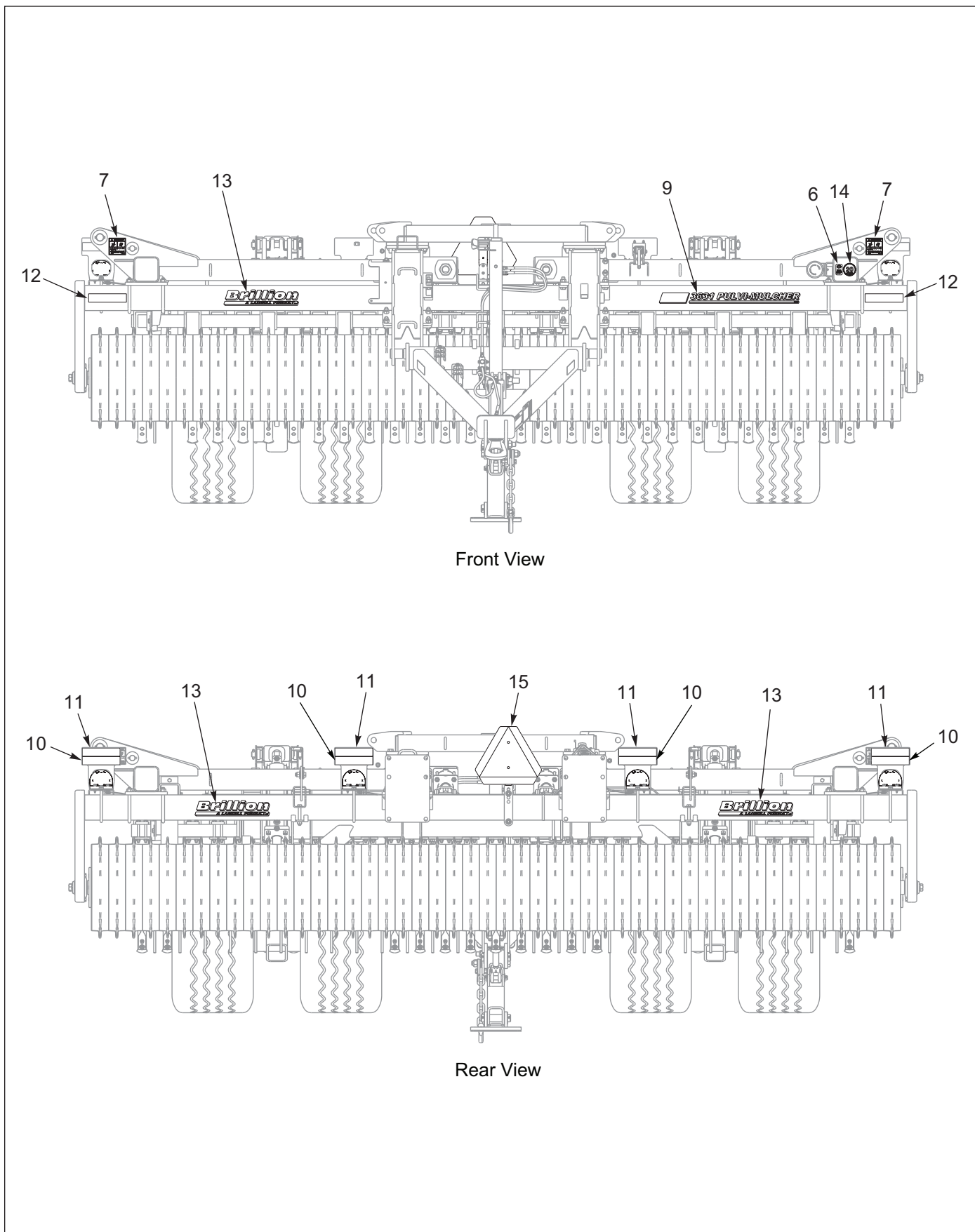
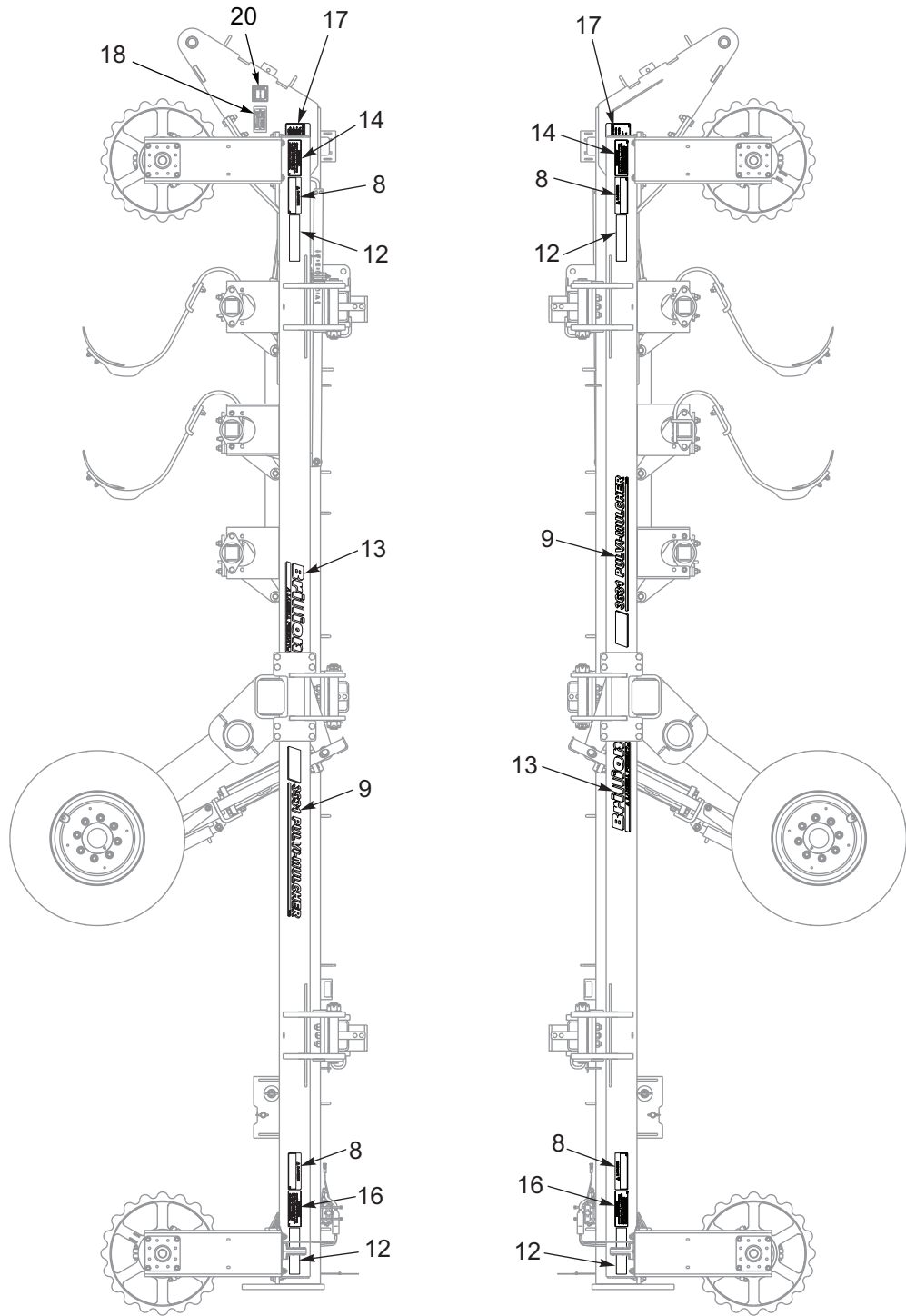

Figure 1-4: Decal Locations (1 of 5)



Side Views

Figure 1-5: Decal Locations, Side Views (2 of 5)

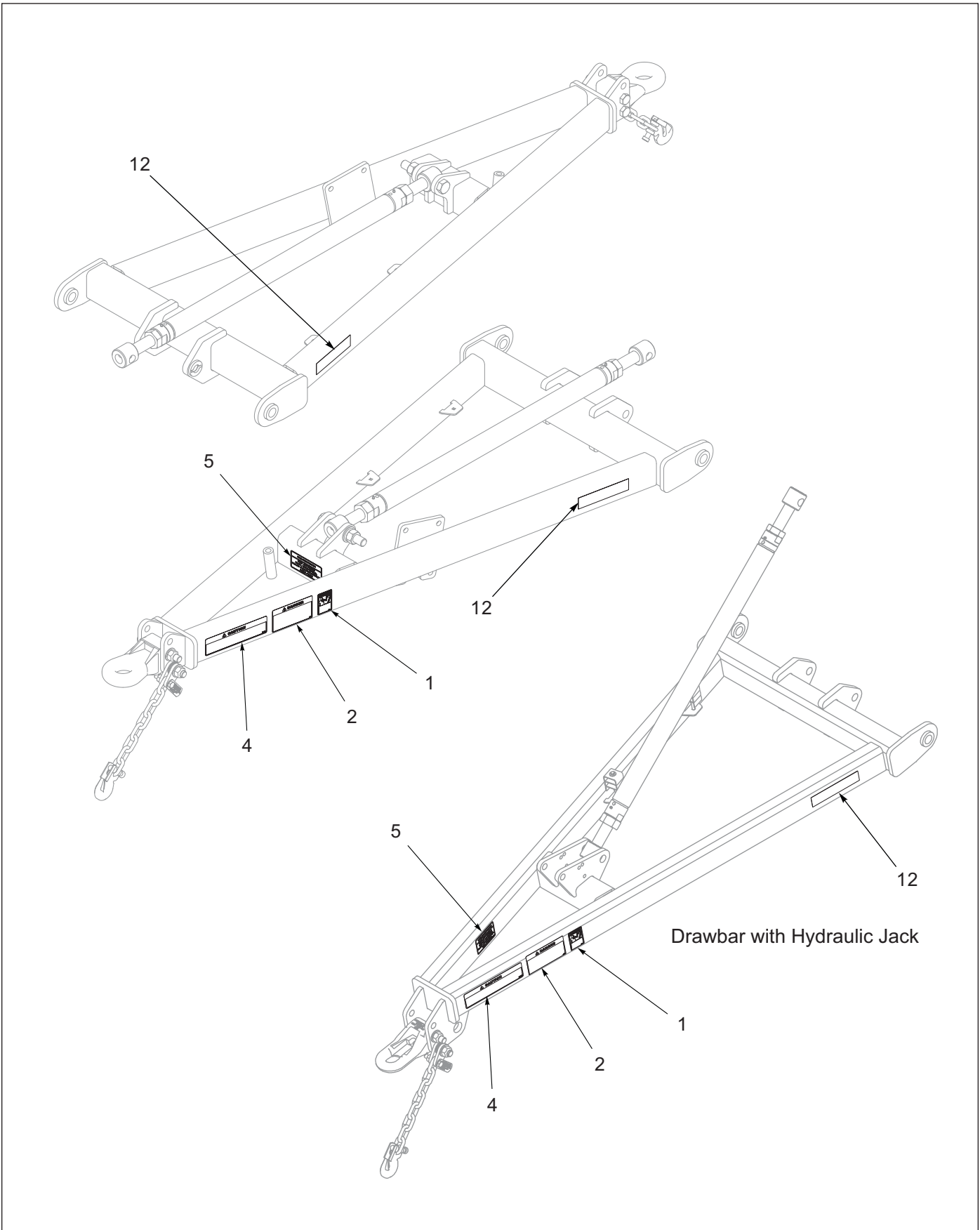

Figure 1-6: Decal Locations, Drawbar (3 of 5)

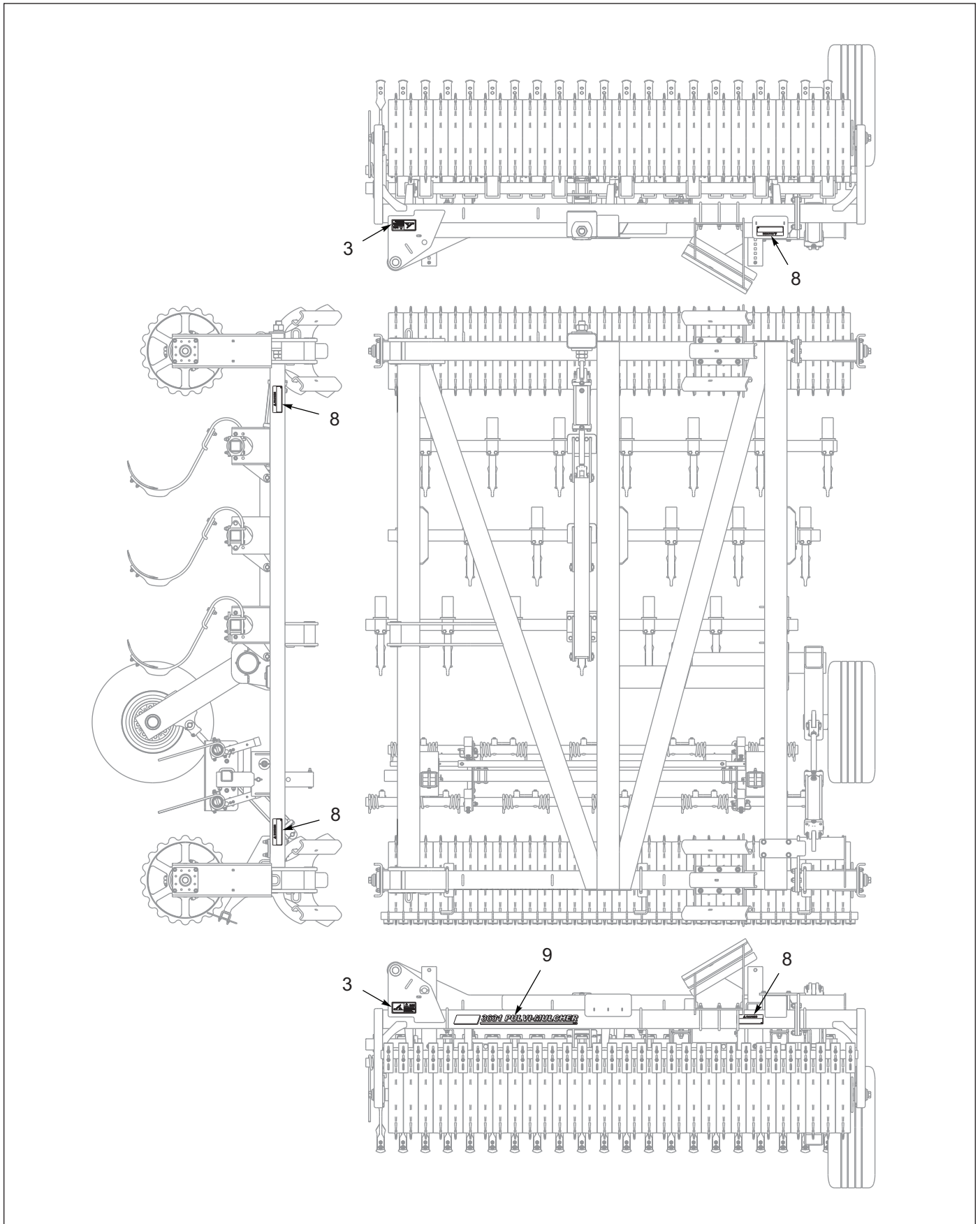

Figure 1-7: Decal Locations, Right Hand Wing (4 of 5)

Assembly



CAUTION

Do not work on or under this machine unless securely blocked and supported by a hoist or tractor or by other sufficient means.



WARNING

Do not attempt to lift heavy parts (such as the Frame, Rockshaft, and Pull Hitch) manually. Use a hoist or a fork lift to move these parts into position.

NOTE

Refer to the repair parts manual F-1063 for identification of parts and for the approximate relationship of the parts in assembly.

To ensure alignment of assemblies, leave the nuts loose until completion of final assembly. Use lock washers or flat washers as specified. Spread all cotter pins.

After completion of final assembly, tighten all nuts evenly to prevent misalignment, distortion or binding. Tighten all screws and nuts to the recommended torques.

IMPORTANT

- If pre-assembled parts or fasteners are temporarily removed, remember where they go. It is best to keep parts separated.
- Check that all working parts move freely, bolts are tight and cotter pins spread.
- Refer to the Torque Table for proper torque values. Note the different torque requirements for Bolts with Locknuts. **See Page 4-1.**

“Left” and “Right” refer to directions seen as if standing behind the machine and facing in the direction of forward travel.

Frame Installation

NOTE

Prior to starting assembly refer to **Figure 2-2** for proper frame placement dimensions. After laying out the dimensions use a chalk or other marker to help place the components.

1. Position the Rockshaft on a level surface under the designated frame assembly area. This will aid in ease of assembly. **See Figure 2-3.**
2. Using blocks or other supports, block up the Right Hand Center Frame approximately 36". Ensure that it is secure and cannot topple. The Rockshaft should be positioned approximately halfway between the supports.
3. Attach the Front and Rear Roller Frame Assembly to the Right Hand Center Frame Assembly. The Right Hand Center Frame Assembly consists of an outside and inside tube. Assemble the outside frame tube using two 3/4-10 U-bolts, and Locknuts. Assemble the inside frame tube using four 3/4-10 x 2-1/2 Bolts and Locknuts. **Do Not** tighten at this time. Be sure to support roller frames.

The process for assembling the Left Hand Center Frame is the same as the Right Hand. **See Figure 2-4.**

4. Double check mounting dimensions at this time.
5. Join the front Right and Left Hand Frames together with Front Cross Tube. Secure with 3/4-10 x 2-1/2 Bolts, Flat Washers and Locknuts. Join the rear Right and Left Hand Frames with Rear Wing Rest Tube. Secure using 3/4 x 5-1/4 Pins, Flat Washers and 1/4 x 1-1/2 Roll Pins.
6. Tighten all Frame Hardware.
7. On the inside Frame, position the Front Roller Support Plate under the Front Roller Frame Tube and secure with eight 3/4-10 x 2-1/2 Bolts and Locknuts. **See Figure 2-1.**

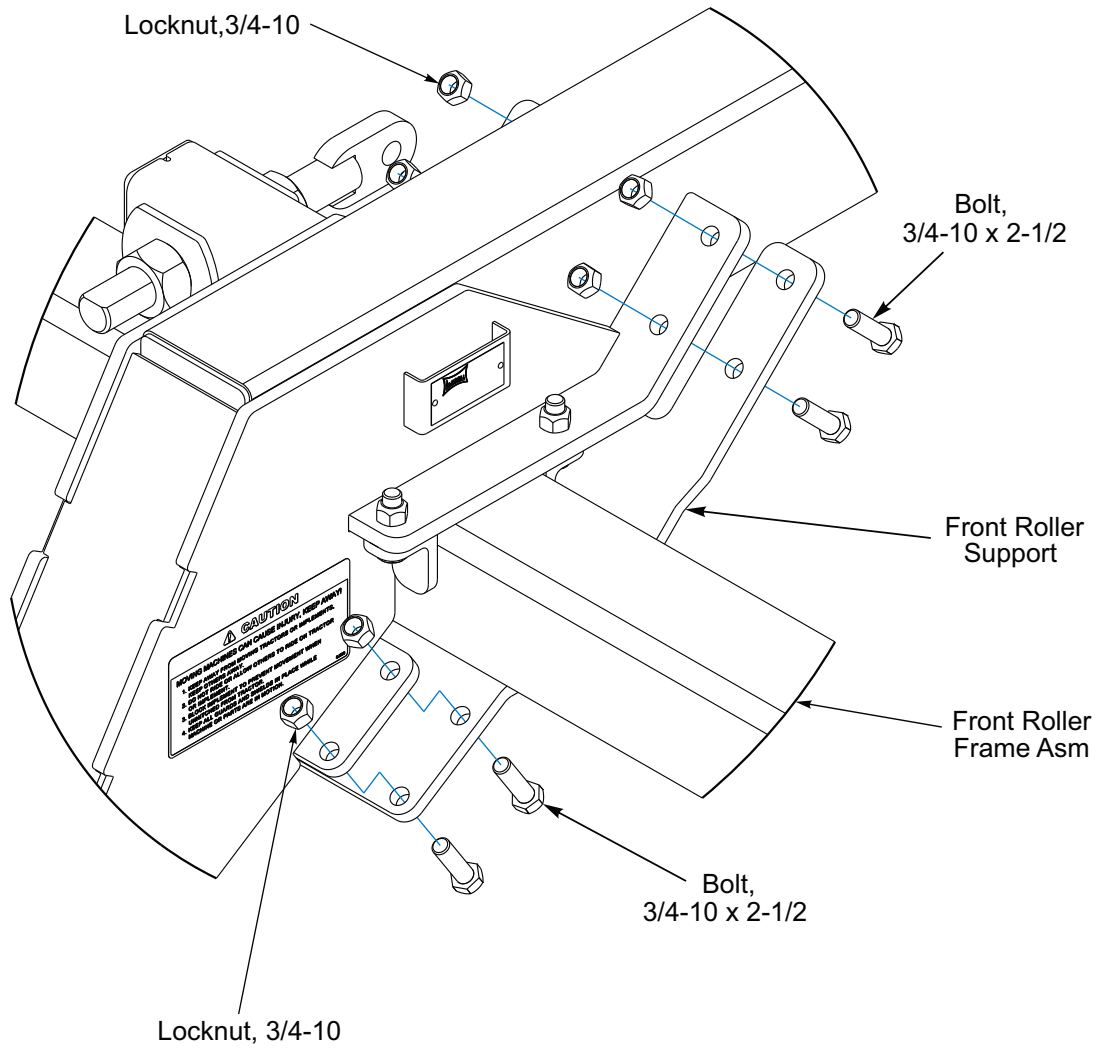

Figure 2-1: Front Roller Support

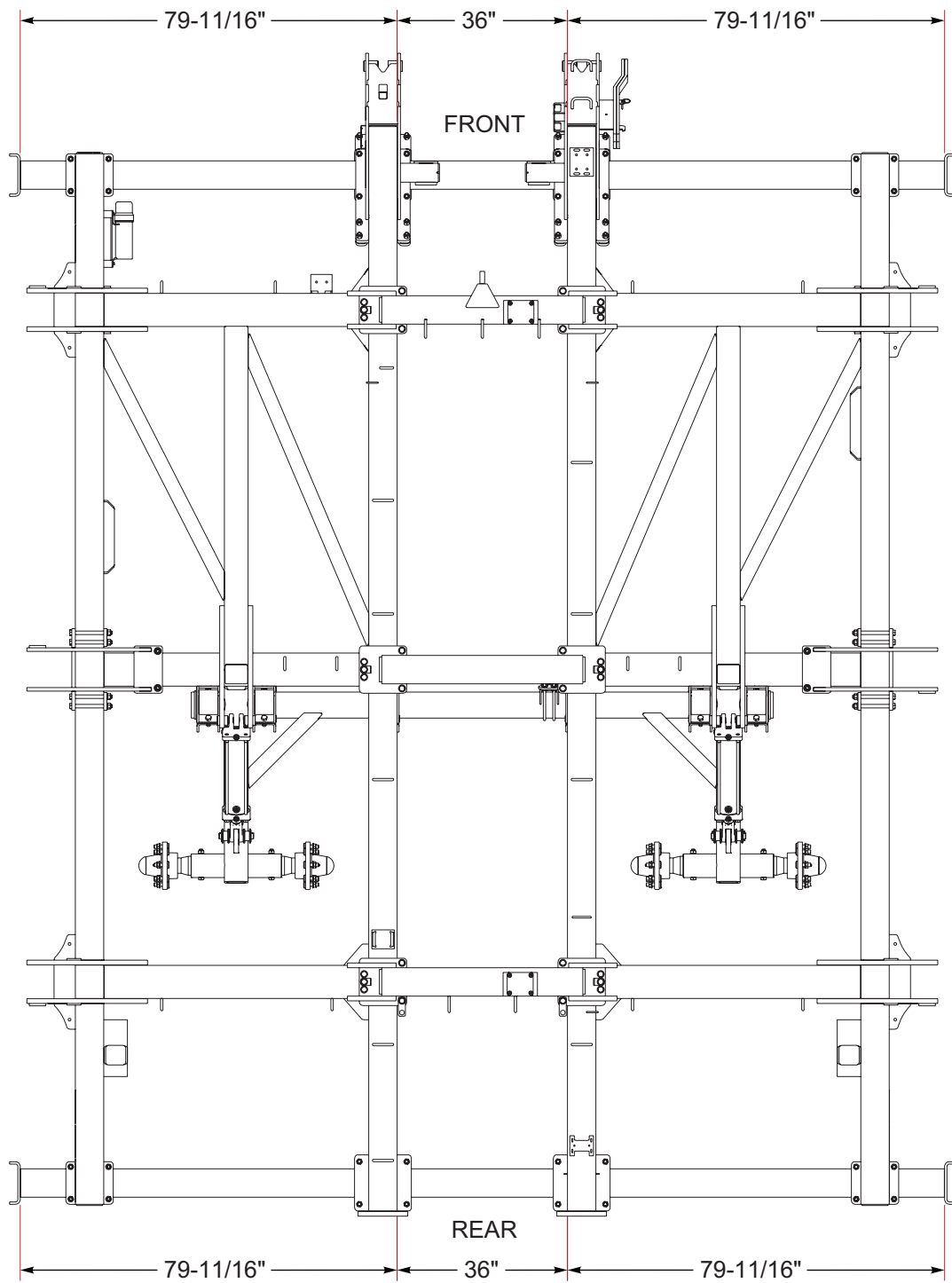

Figure 2-2: Center Frame Dimensions

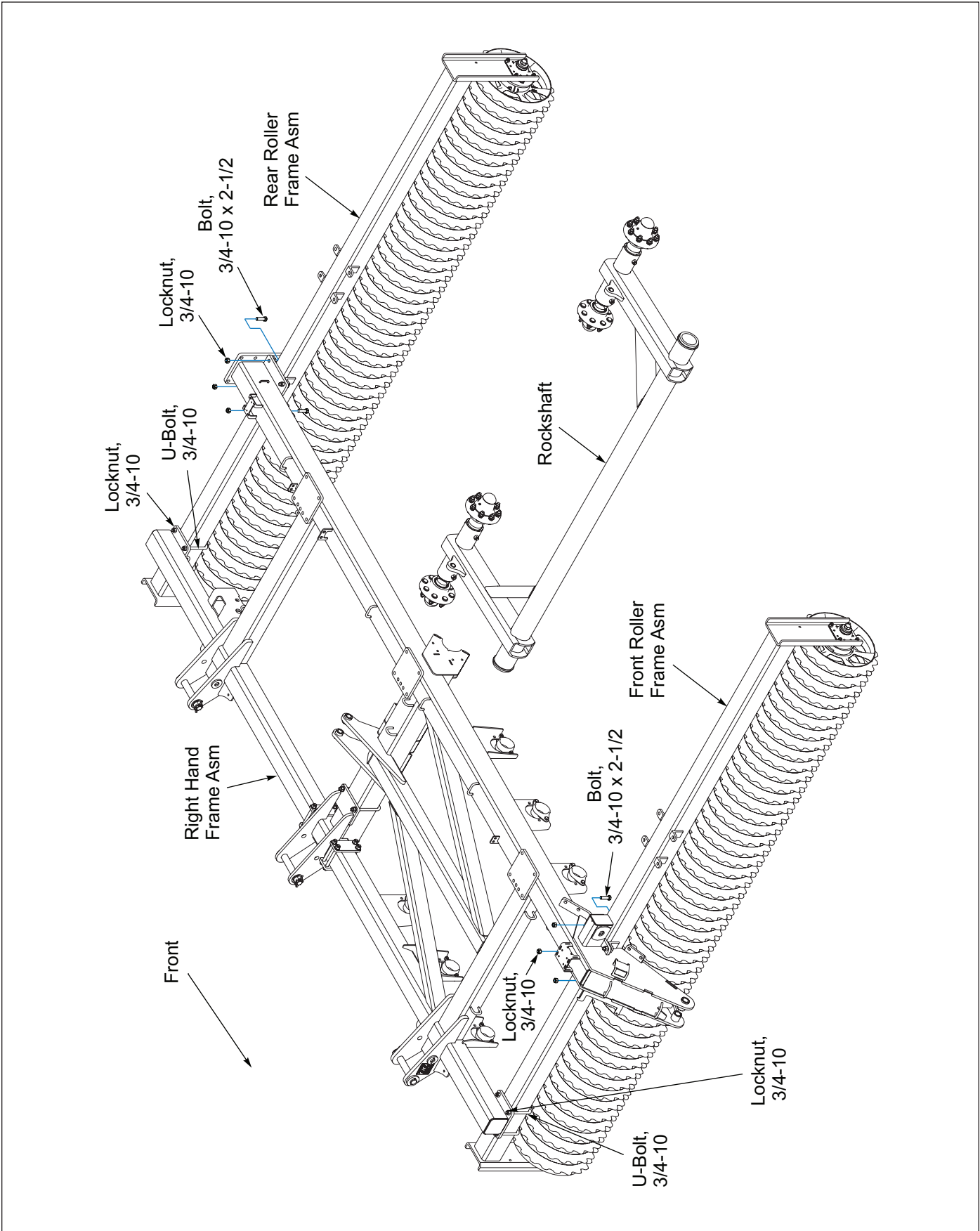

Figure 2-3: Right Hand Center Frame

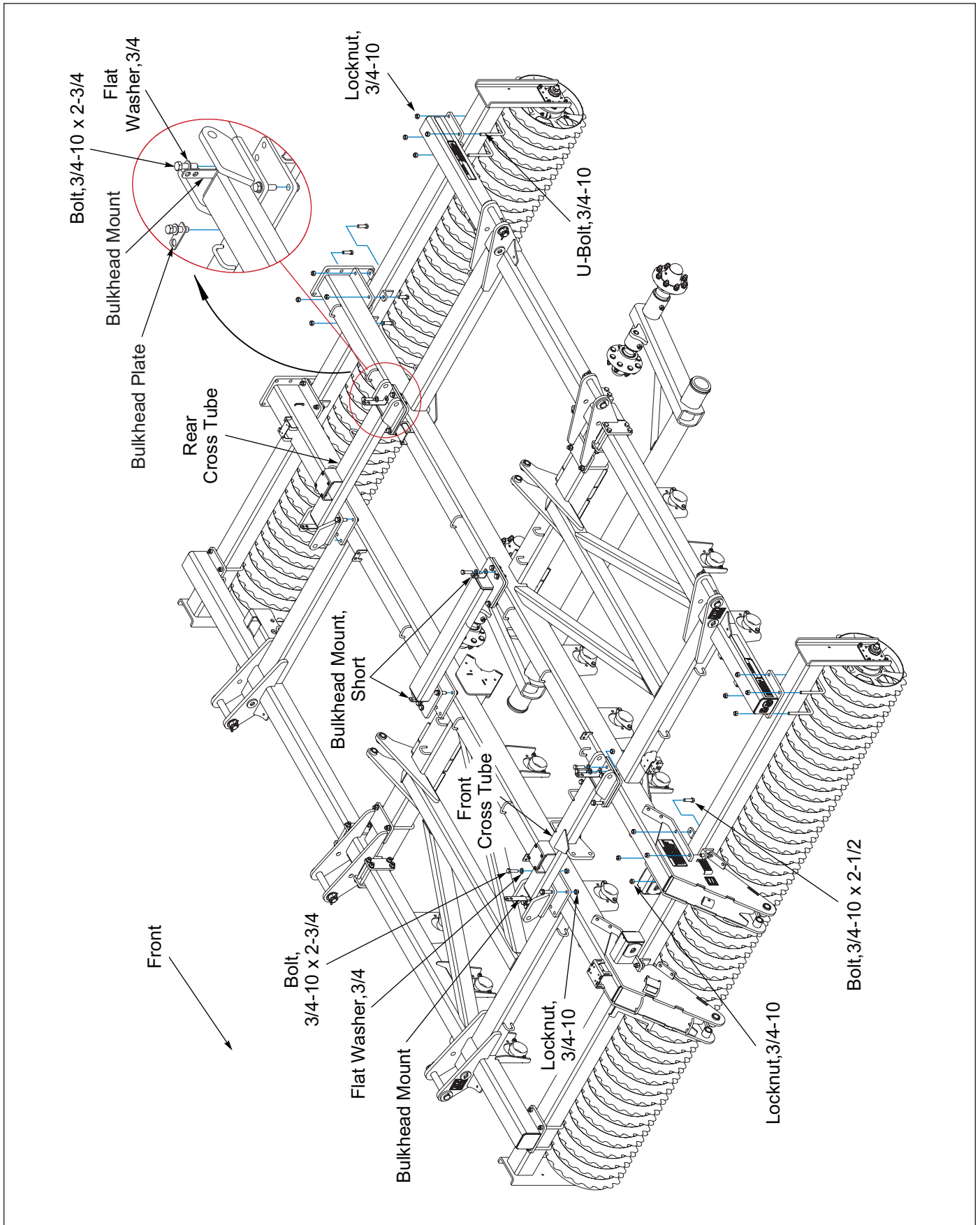

Figure 2-4: Center Frame

Rockshaft Installation

! WARNING

Do not attempt to lift heavy parts (such as the frame, rock shaft, and pull hitch) manually. Use a hoist or a fork lift to move these parts into position.

2. Position the Rockshaft into the Frame Mounts. Place the Lift Cap Bearing and fasten with 3/4-10 x 2 Bolts and Locknuts. Ensure the UHMW Bearings are seated properly into Caps and Frame Mounts. Repeat for the remaining Lift Cap bearings. Tighten Bolts. See “General Torque Specifications” on page 4-1.

1. Spread open the six UHMW Bearings and place them onto the Rockshaft. Make sure the mounting surface is free of rust or dirt. See Figure 2-5.

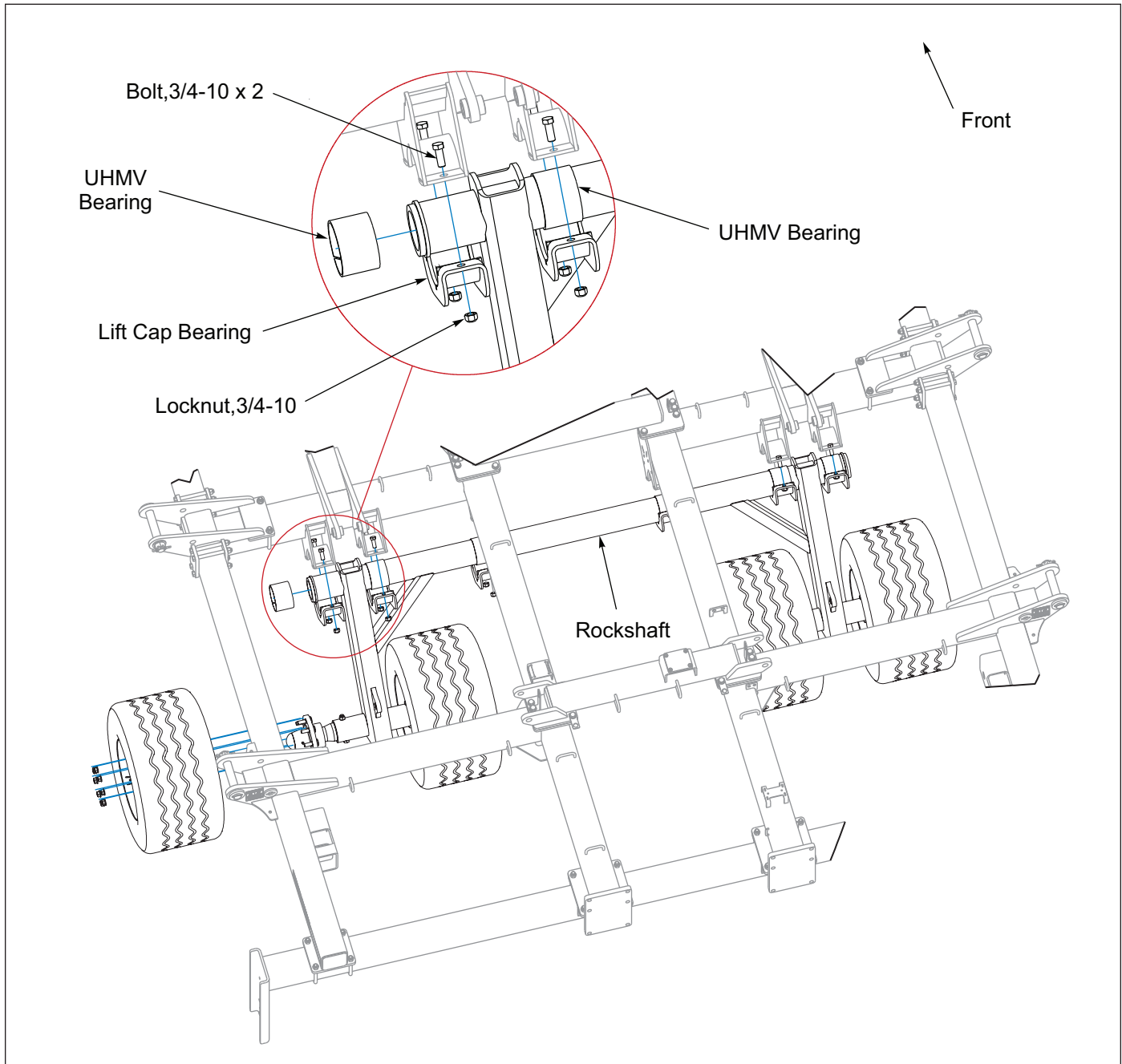

Figure 2-5: Rockshaft Installation

Rockshaft Cylinder and Transport Lock Installation

1. Align Transport Lock with Frame Lugs. Insert Pin through one side of Transport Lock and one Frame Lug. Align 14 x 4-1/2 Hydraulic Cylinder base end with Frame Lugs. Hydraulic ports should be rear facing. Secure with Pin. Install Washers and Roll Pins. **See Figure 2-6.**

2. Attach 4-1/2 x 14 Hydraulic Cylinder rod end to Rockshaft Arm. Secure with 1-1/4 x 7-5/16 Pin. Install Guide Rollers, Washers, and Roll Pins.

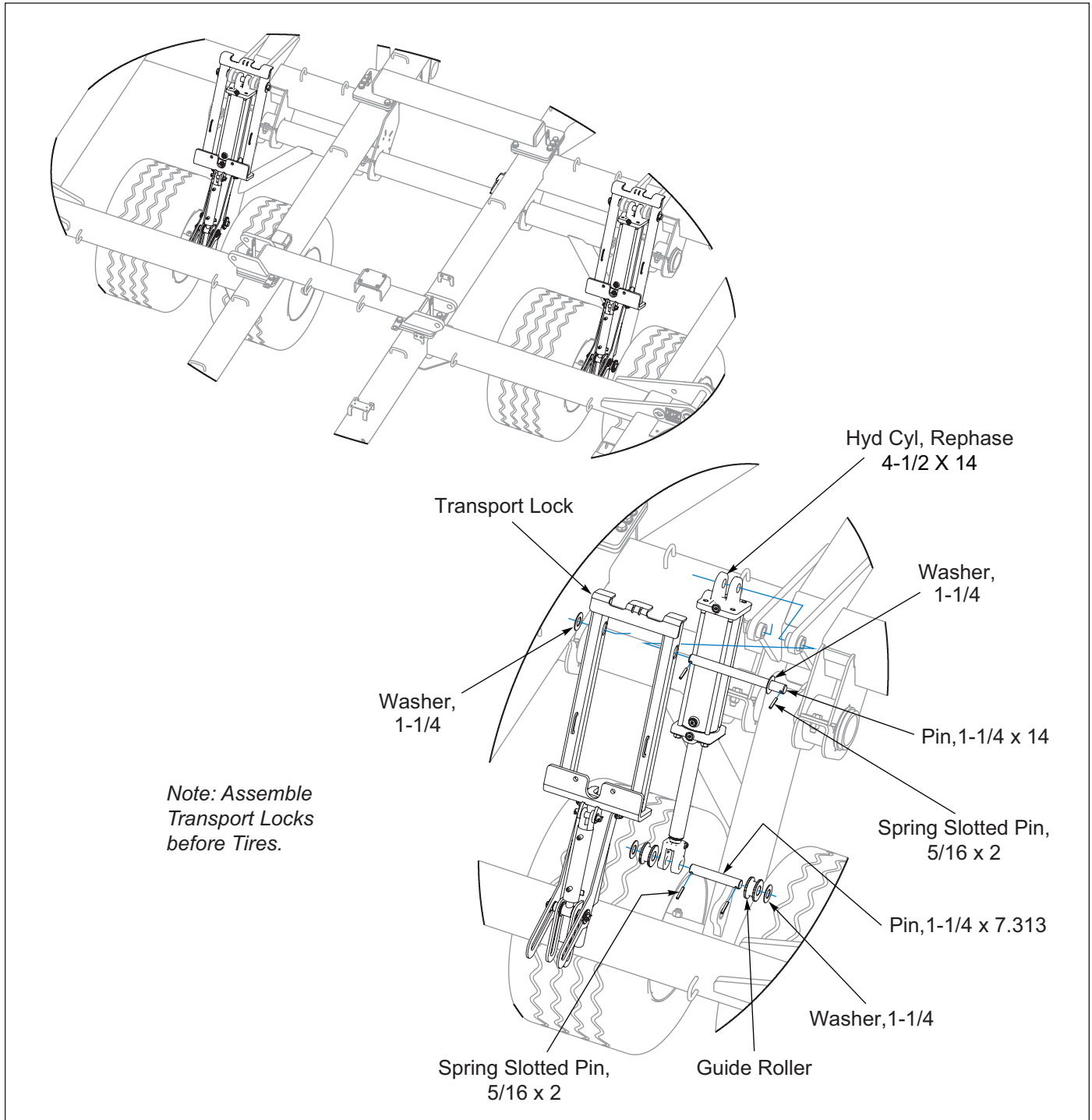

Figure 2-6: Rockshaft Cylinder and Transport Lock Installation (Hydraulic)

Wheel Installation



WARNING

Use a torque wrench to assure proper torque. Insufficient torque can cause stud breakage and damage the wheel pilots. Over torque can stress the studs and strip the threads.

NOTE

All tire/wheel assemblies are mounted with the valve stem facing outward from Hub and Spindle.

1. Remove the eight 3/4-16 Flange Nuts from the Hub. Install the Tire and Wheel Assembly onto the hub. The Pulvi-Mulcher uses 480/45R17 tires and should be inflated to 73 PSI. See Figure 2-8.
2. Re-Install the 3/4-16 Flange Nuts and tighten to 50 ft-lbs using the sequence in Figure 2-7. Then tighten to full torque of 220 ft-lbs.

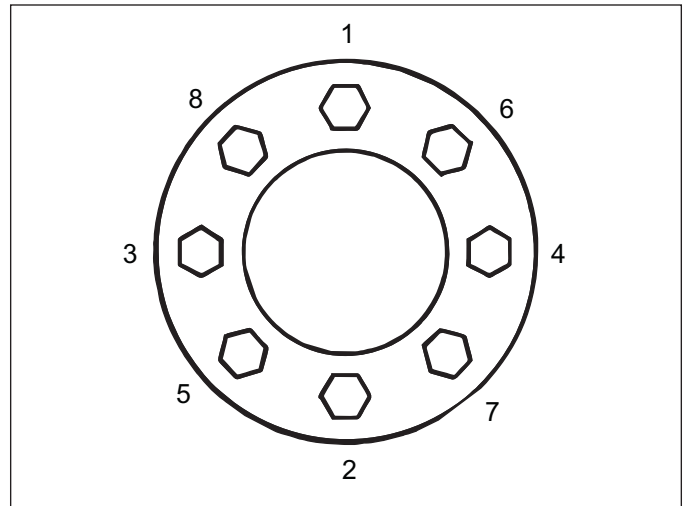

Figure 2-7: Stud Tightening Sequence

NOTE

Torque will drop after the first 10 hours of operation. Check the nuts for proper torque after this interval and re-tighten them.

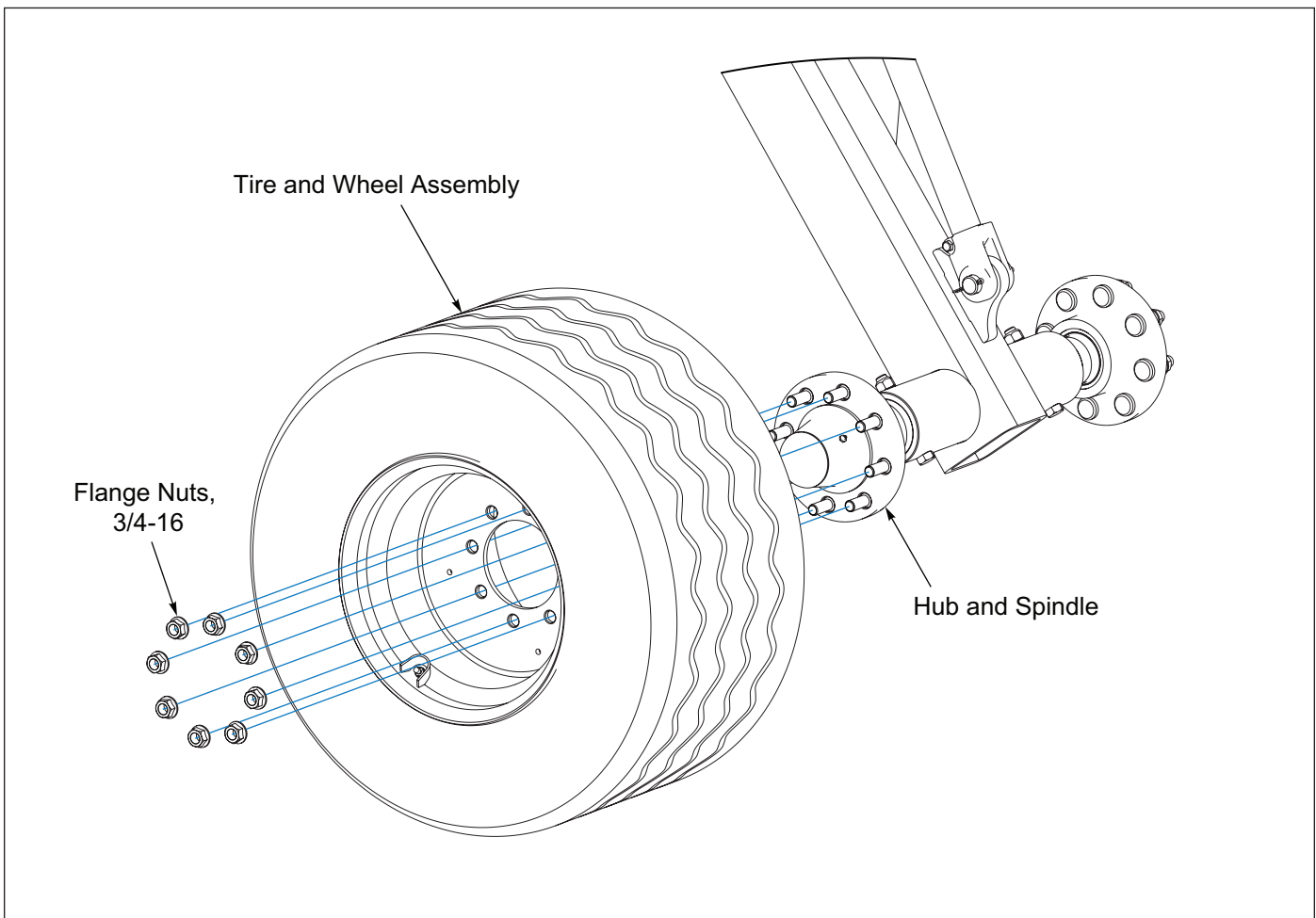

Figure 2-8: Tire and Wheel Assembly

Drawbar w/ Manual Jack Installation

1. Position the Hitch Leveler between the center lugs and reinstall the 1-1/4 x 12-1/2 Pin, 1-1/4 x 2-1/2 12ga Washer and 1-1/4 x 2 Roll Pin. **See Figure 2-9.** Attach the bottom of the Hitch Leveler to the Drawbar by removing the 5/16 x 2 Roll Pin, 1-1/4 x 2-1/2 12ga Washer and 1-1/4 x 12-1/2 Pin.
2. Mount the Drawbar to the lugs on the front of the frame, slide the 1-7/16 x 10-1/4 Pins into the frame bushings. Place a washer 1-1/2 x 2-1/4 x 10ga on each end of Pin and secure with 3/8 x 2-1/4 Roll Pins.
3. Install the Turnbuckle to the Leveler with 1-1/4 x 8-1/4 Pin. Place a 1-1/4 x 1-7/8 x 14ga Washer on each end of pin and secure with 5/16 x 2 Roll Pins.
4. Attach the Jack to the drawbar using four 3/4-10 x 2-1/2 Bolts and Locknuts.
5. Attach the Hose Holder Bracket to the Drawbar using 3/4-10 x 7 Bolt, with flange up thread one 3/4-10 Serrated Flange Nut onto the bolt, place the Hose Holder Bracket over the bolt and against the flange of the installed nut. Thread the second 3/4-10 Serrated Flange Nut with flange down tight. Nut serrations should be against Bracket. Bracket should swivel when installed.
6. Attach the Connector Holder using two 1/4-20 x 1 Bolts and Locknuts.
7. Hose Holder Clamp and Hose Holder Wing Nut can be installed now or after Hydraulic Hoses are installed. Insert 3/8-16 x 5 Bolt into Hose Holder Bracket and secure with Hex Nut. Place Hose Holder Clamp over the bolt and secure with Hose Holder Wing Nut.

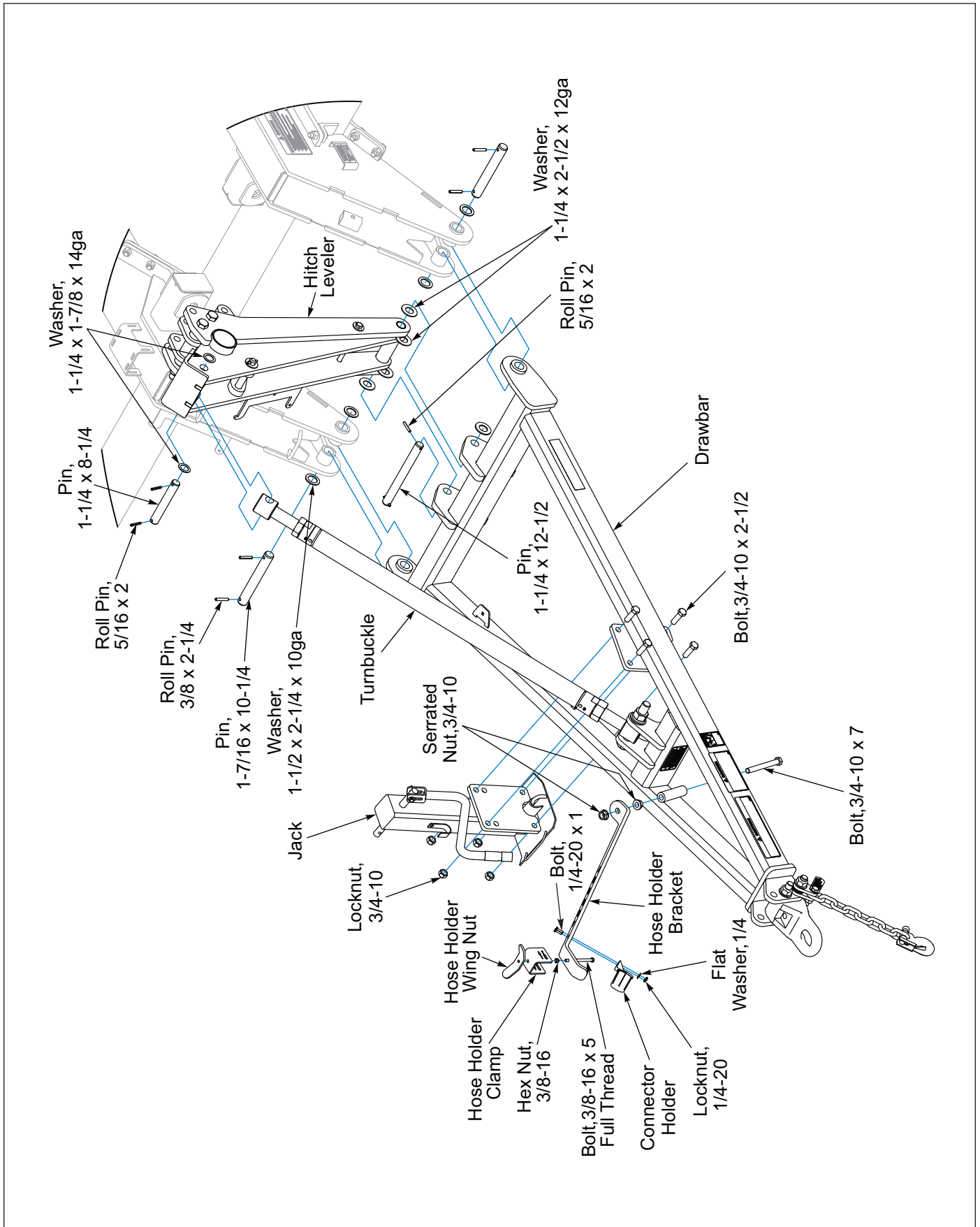

Figure 2-9: Drawbar Installation

Drawbar w/ Hydraulic Jack Installation

1. Attach bottom of the Jack Tube to the Jack Base with Jack Pivot Tube. Place 1-3/4 Thrust Washers on each end of the Jack Pivot Tube and secure with 5/16 x 2-1/2 Slotted Pin. **See Figure 2-11.**
2. Attach top of the Jack Tube to the Drawbar with Jack Pivot Tube. Place 1-3/4 Thrust Washers on each end of the Jack Pivot Tube and secure with 5/16 x 2-1/2 Slotted Pin.
3. Put the Base End of the 3 x 8 Hydraulic Cylinder between the Drawbar, Center Bracket and insert 1 x 6 Pin. Place 1" Flat Washer on each side of Drawbar Center Bracket and secure with 5/16 x 2 Slotted Pin.
4. Attach the Rod End of the 3 x 8 Hydraulic Cylinder to the Jack Tube with 1 x 5-1/2 Pin. Place 1" Flat Washer on each side of Jack Tube and secure with 5/16 x 2 Slotted Pin.
5. Install the 1-1/4-7 x 8 Bolt, 1-1/4 Flat Washer, 1-1/4 Lock Washer and 1-1/4-7 Hex Nut into the rear hole of the Drawbar, Center Bracket.
6. Install Double Pilot Check Valve Fittings. **See Figure 2-10.**
7. Assembly the Double Pilot Check Valve to the Valve Bracket with 3/8-16 x 2-1/4 Bolt, 3/8 Flat Washer and 3/8-16 Flange Locknut.
8. Attach the Valve Bracket and Hose Support to the Drawbar, Center Bracket with 1/2-13 x 6 Bolt and 1/2-13 Flange Locknuts.
9. Install the Tooth Clamps to the Hose Support using 1/2-13 Locknuts. Place the 1/2 x 4-1/2 Clevis Pin into the Hose Support and secure with 1/8 Hairpin Cotter.
10. Install fittings and hoses for Drawbar Hydraulic Cylinder.
11. Insert 3/8-16 x 5 Bolt into Hose Holder Bracket and secure with hex nut. Place Hose Holder Clamp over the bolt and secure with Hose Holder Wing Nut.
12. **See "Drawbar w/ Manual Jack Installation" on page 2-10, Steps 1 through 3,** to continue with Drawbar Assembly.

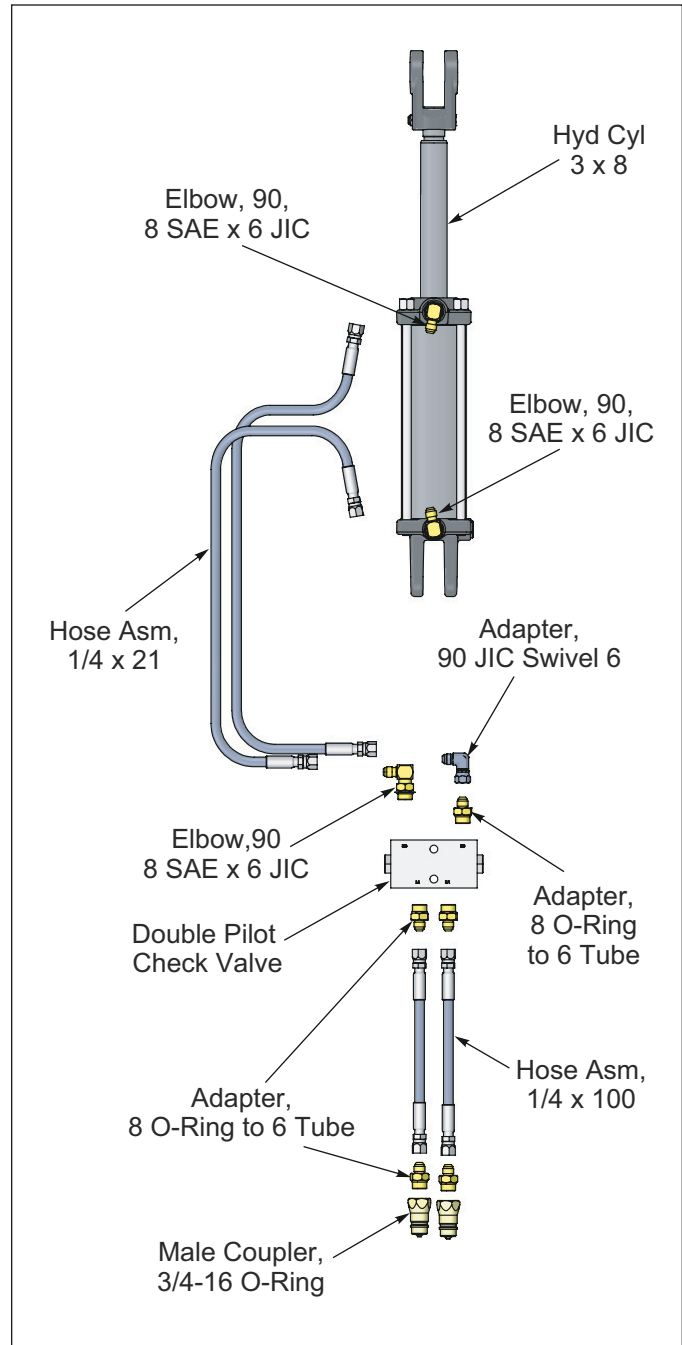

Figure 2-10: Drawbar w/ Hydraulic Jack Installation

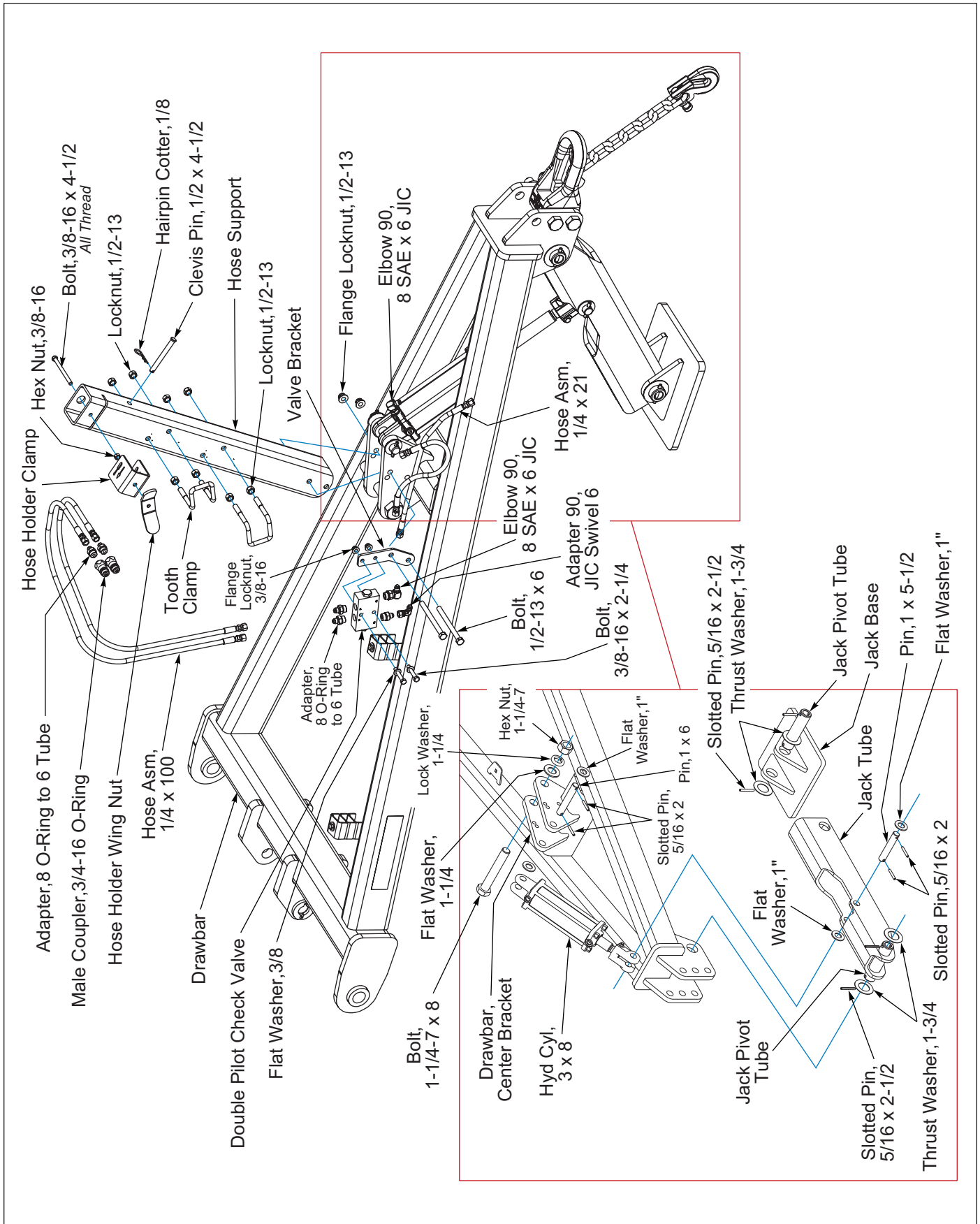

Figure 2-11: Drawbar w/ Hydraulic Jack Installation

Drawbar Leveling Installation

1. Assemble the Leveling Cylinder Bracket to the center of the Front Roller Frame Tube with 3/4-10 U-Bolts and Locknuts. **Do Not** Tighten at this time. **See Figure 2-14.**
2. Install Tie Rod Assembly to the Front Cross Tube Lug bottom hole and insert 1 x 3-1/4 Clevis Pin. Add a 1 x 2 x 11ga Washer and secure with 3/16 x 1-1/2 Cotter Pin.
3. Before proceeding with the Drawbar Leveling Installation, connect the Drawbar to the Center Frame. **See “Drawbar w/ Manual Jack Installation” on page 2-10 or “Drawbar w/ Hydraulic Jack Installation” on page 2-12.**
4. Put the base end of the 4 x 8 Hydraulic Cylinder between the Leveling Cylinder Bracket Lugs. Swing the Tie Rod Assembly between the Cylinder Base End Clevis and insert 1 x 6 Pin. Place a 1 x 2 x 11ga Washer on each side and secure with 5/16 x 2 Roll Pins. Pivot the Hitch Leveler Link and attach it to the rod end of the 4 x 8 Cylinder with the vendor supplied hardware. Tighten Leveling Cylinder Bracket Hardware.

IMPORTANT

Remove and discard the 5/8-11 x 10 Bolt, Flat Washer and Hex Nut that is holding the Hitch Leveler together, so that the outer portion can pivot rearward.

5. Remove 1-8 x 11 Bolts that secure the Leveler Mount at the top of the Hitch Leveler. Remove Lift Strap from the Transport Lock by loosening the 1/2" Flange Nuts. Place the Lift Straps on each side of the Leveler Mount and reassemble with 1/2" Flange Nuts and 1/2-13 x 1-3/4 Screw. Replace 1-8 -11 Bolts, 1" Lock Washers and 1-8 Nuts. **See Figure 2-12.**

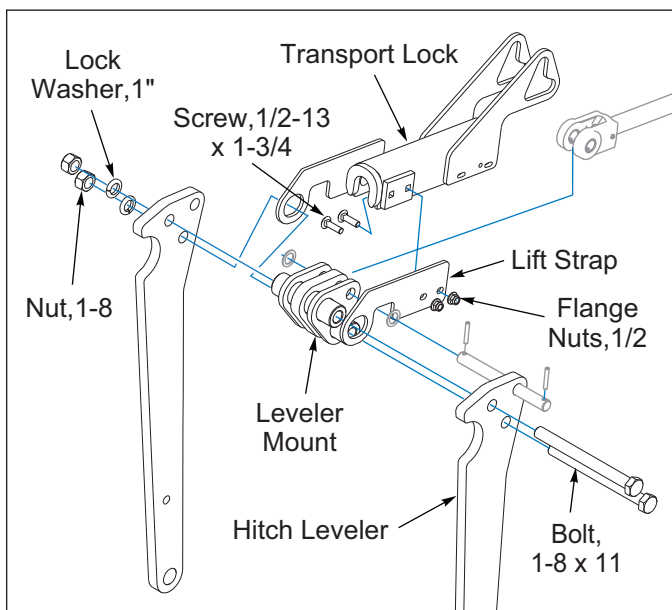

Figure 2-12: Leveler Mount / Hitch Leveler Detail

6. Place the base end of the 4 x 16 Hydraulic Cylinder with the Transport Lock Assembly onto the Front Cross Tube Lug top hole. Place 1-1/2 x 2 Bushings on each side of the 4 x 16 Hydraulic Cylinder and secure with 1 x 12.75 Pin and 1 x 2 x 11ga Washers and 5/16 x 2 Spring Slotted Pin.
7. Secure the Transport Lock Assembly to the top of the 4 x 16 Hydraulic Cylinder with 1/2-13 x 5-1/2 x 6-1/4 U-bolts and 1/2-13 Flange Nuts.
8. Pivot the rod end of the Cylinder between the Leveler Mount and insert 1 x 10-1/8 Pin through components. Place a 1 x 1-1/2 x 14ga Washer on each end of the Pin and secure with 5/16 x 2 Roll Pins.
9. Connect the Transport Lock to the Transport Lock Assembly. Remove the existing Transport Lock Assembly hardware located at the rod end of the 1-3/4 x 6 Hydraulic Cylinder. Place the Transport Lock between the .75 x 2.75 x .375 Washers and secure with .75 x 5.313 Pin and 3/16 x 1-1/2 Spring Pin. **See Figure 2-13.**
10. Set Turnbuckle Pin Hole Center to Center at 60" for initial setting.

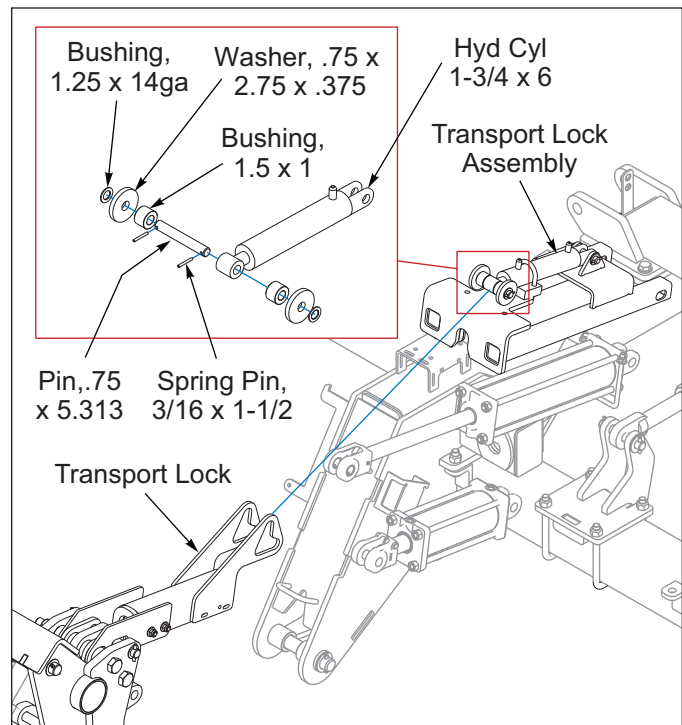

Figure 2-13: Transport Lock to Transport Lock Assembly Installation

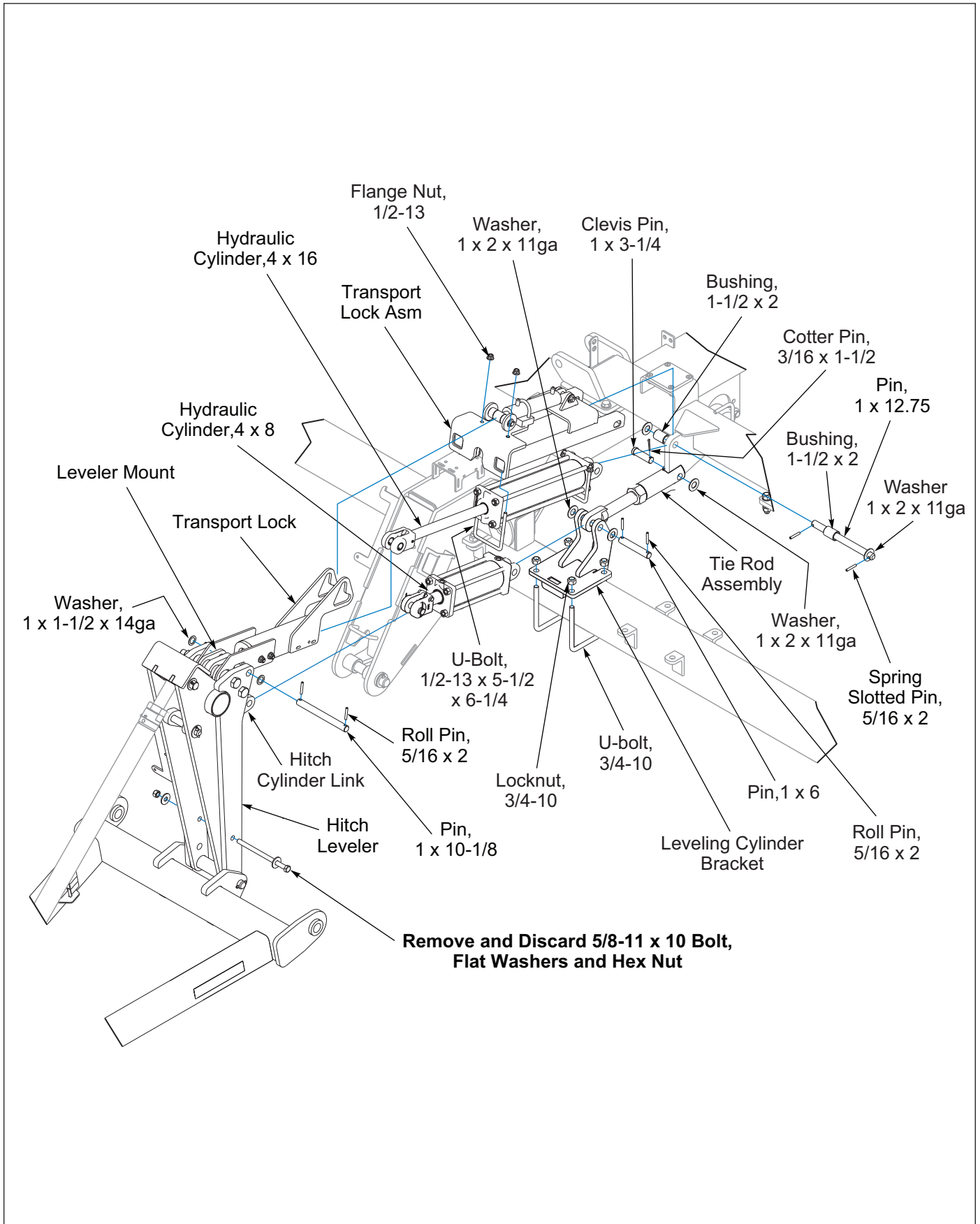

Figure 2-14: Drawbar Leveler

Manual Holder and Wrenches Installation

Attach the Manual Holder to the frame using 1/4-20 x 1 Bolts, Flat Washers and Locknuts. Attach the two Open End/Box End Wrenches to the side of the Center Frame and the two Open End Wrenches to the side of the Hitch Leveler. Secure with 1/4 x 1-1/4 Lynch Pins.

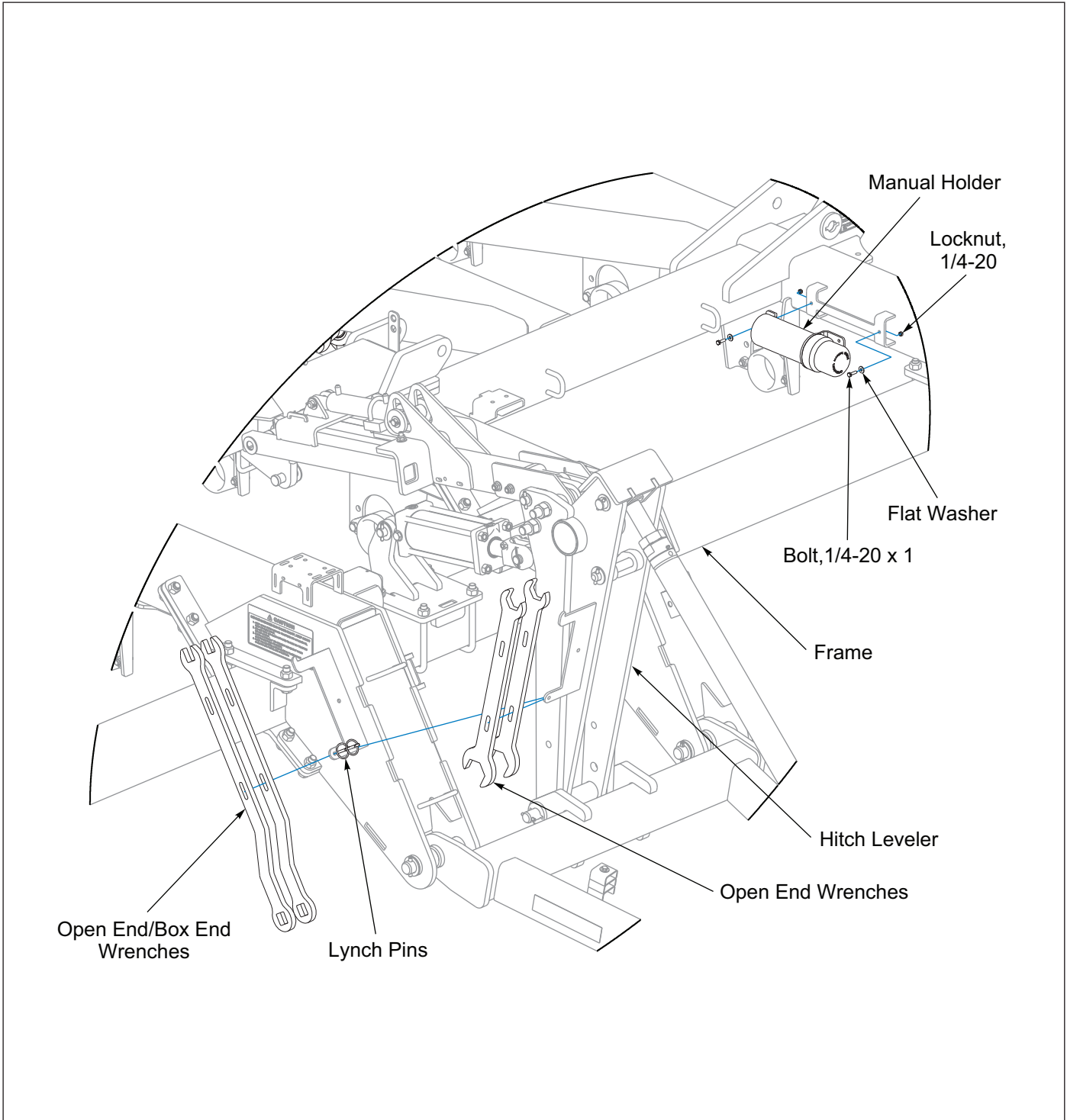

Figure 2-15: Manual Holder and Wrenches

Wing Fold Hydraulic Cylinder Installation

LH Side: Mount four 4-1/2 X 30 Hydraulic Cylinders without Spacers

RH Side: Mount four 4-1/2 X 30 Hydraulic Cylinders with Spacers

Ports on the front Hydraulic Cylinders in each pair face forward. Ports on the Rear Cylinder in each pair face rearward. **See Figure 2-16.**

1. Attach the base end of the 4-1/2 X 30 Hydraulic Cylinders on the Center Frame Front and Rear Crossmembers with the vendor supplied hardware. Orient Cylinder Ports for each set to face away from each other.
2. Block Cylinder Rod Ends up from the frame to allow for rod movement when purging the Fold Circuit.

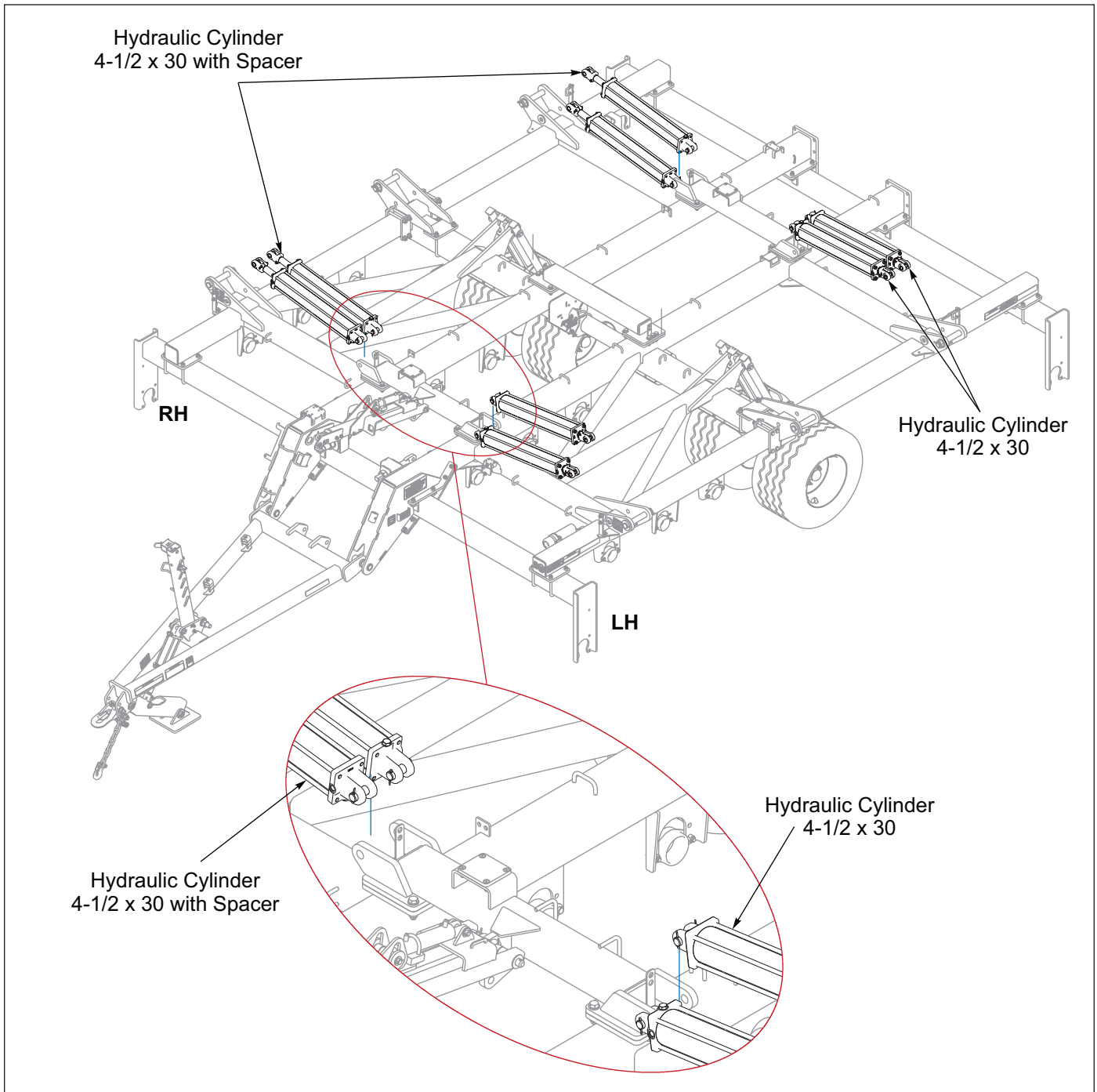

Figure 2-16: Wing Fold Hydraulic Cylinder Installation

Tooth Control Center Frame Cylinder Installation

Install the base end 4-1/2 x 8 Rephasing Hydraulic Cylinders to the Cylinder Anchors on the front of the LH and RH Center Frames with the vendor supplied hardware. Cylinder ports face up. Adjust the Anchor Nuts to achieve a distance of approximately 7-1/2" from the Center Frame Tube to the center of the Cylinder Pin. See Figure 2-17.

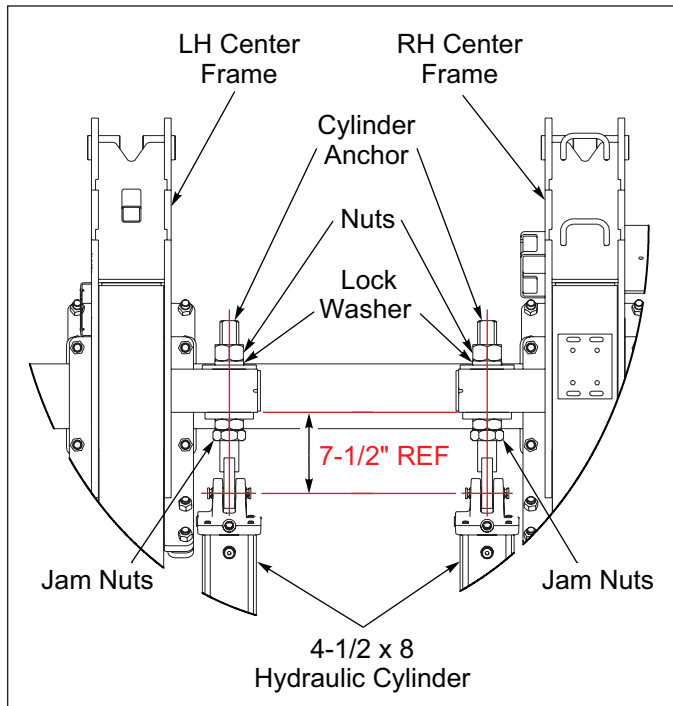

Figure 2-17: Center Frame Distance

Hydraulics



WARNING

Escaping fluid under pressure can be nearly invisible and have enough force to penetrate the skin causing serious injury. Use a piece of cardboard, rather than your hands, to search for suspected leaks. Wear protective gloves & safety glasses or goggles when working with hydraulic systems.

The hydraulic system consists of 3 separate circuits. Plumb the circuits in the following order:

1. Tooth Control Circuit - Black - See Figures 2-18, 2-19 and 2-20. The Tooth Control Circuit with shanks raised requires approximately 2.3 gallons of hydraulic oil, and with shanks lowered requires 2.6 gallons of hydraulic oil.
2. Fold Circuit - Yellow - See Figures 2-24, and 2-28. The Fold Circuit with wings folded, requires approximately 8.7 gallons of hydraulic oil and with wings unfolded, requires 10.6 gallons of hydraulic oil.
3. Lift Circuit - Blue - See Figures 2-33 and 2-34. The Lift Circuit with machine raised, requires approximately 4.1 gallons of hydraulic oil and with machine lowered, requires 3.7 gallons of hydraulic oil.

Tightening Procedure For JIC 37° Swivel Female Nuts

1. Check flare and seat for defects.
2. Lubricate the connection.
3. Install hoses without twists.
4. Hand tighten until connection bottoms.
5. Using 2 wrenches to prevent twisting, rotate the swivel nut 2 wrench flats (1/3 turn).
6. For reassembly, follow the same procedure but tighten only 1 wrench flat (1/6 turn).

Tightening Procedure For Swivel O-Ring Fittings

1. Lubricate O-Ring and install the fitting until the metal washer which backs up the O-Ring contacts the face of the boss.
2. Orient the fitting by turning counterclockwise up to 1 turn.
3. Tighten the lock nut using 50-60 foot pounds torque. See "Hydraulic Fitting Torque Specifications" on page 4-2.

Plumb Tooth Control Circuit

1. Install Limit Valve fittings. **See Figures 2-18 and 2-20.**
2. Install Limit Valve and Depth Stop Guide to frame bracket with 5/16-18 x 5 Bolts and Locknuts. **See Figures 2-19 and 2-41.**
3. Install fittings and hoses for Tooth Control Hydraulic Cylinders. **See Figures 2-18, 2-19 and 2-20.** On each side, wrap both hoses near the hinge pin area with 26 inch hose wrap. Wing hoses can be set aside until time of wing assembly.
4. Route hoses down right side of drawbar. Wrap the Tooth Control System hoses near the Tractor Tips with black hose wrap.

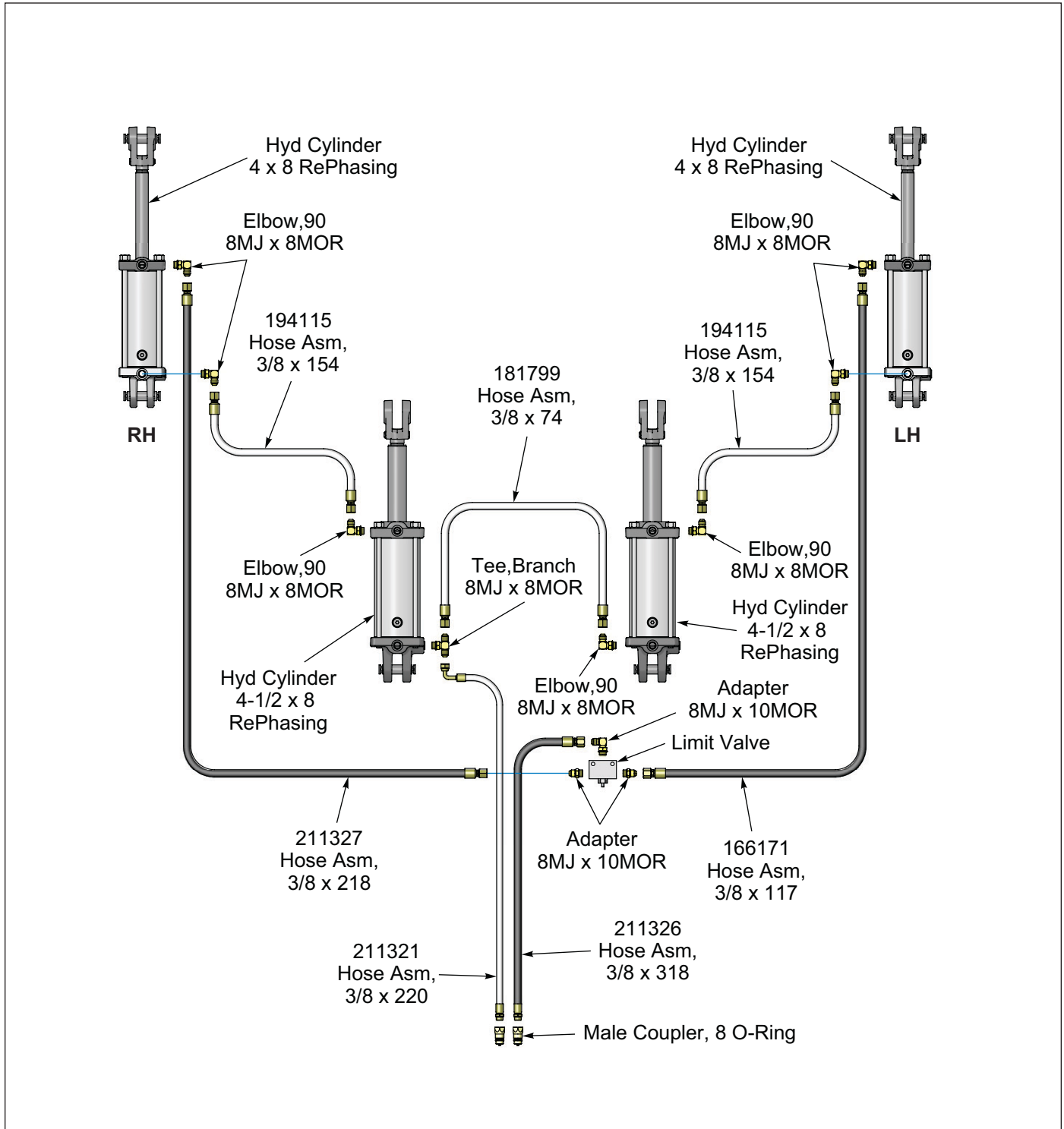

Figure 2-18: Simplified Hydraulic Tooth Control Schematic

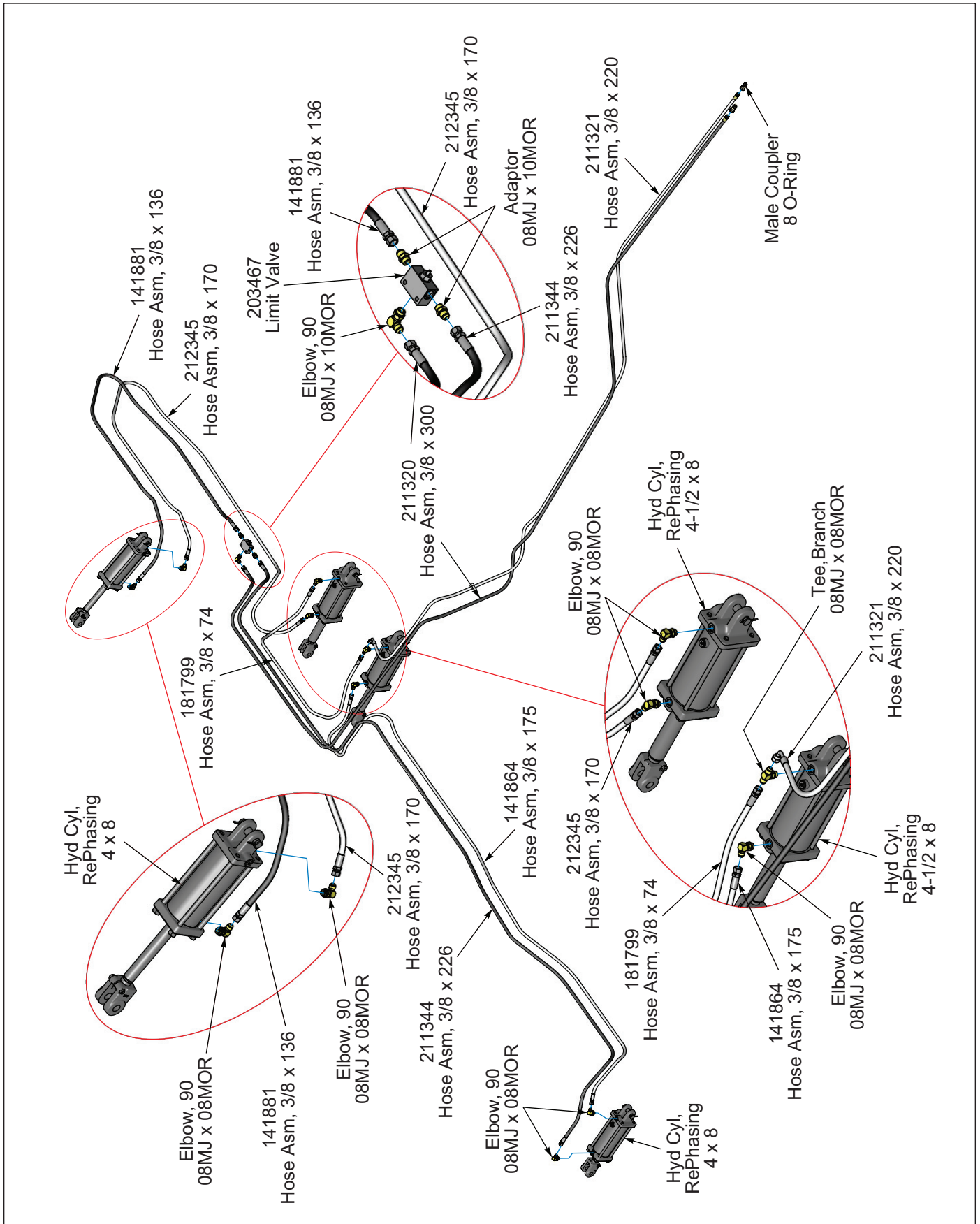

Figure 2-20: Hydraulic Tooth Control Schematic

Plumb Fold Circuit

1. Attach Fold/Down Pressure Valve to Frame Bracket with 3/8-16 x 1 Bolts, Flat and Lock Washers and attach Relief Valve to Frame Bracket with a 1/4-20 x 2-1/4 Bolts, Flat Washers and Locknuts. **See Figure 2-21.**

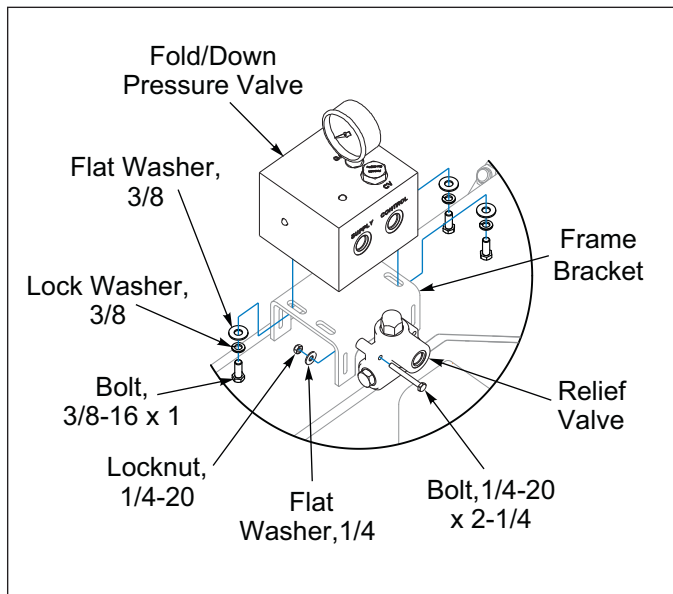

Figure 2-21: Fold/Down Pressure and Relief Valves

2. Install Elbow Restrictors into Fold Cylinders. *NOTE: Restrictor size is different on LH Rod End Cylinders. See Figures 2-24 and 2-25.*
3. Install Bulkhead Tees to Mounting Plates at each Cross-Member Location near rear Fold Cylinders. **See Figures 2-24 and 2-25.**
4. Install the Fold/Down Pressure Valve and Relief Valve fittings and hoses. **See Figures 2-22 and 2-23.**
5. Install Supply Hoses, Fold Cylinder Hoses, and Transport Lock Hoses.
6. Route hoses to tractor from Fold/Down Pressure Valve and down right side of drawbar. Wrap Fold System hoses near the Tractor Tips with Yellow Hose Wrap.
7. Install Gauge into top of Fold/Down Pressure Valve.
8. Secure all hoses with tie wraps.

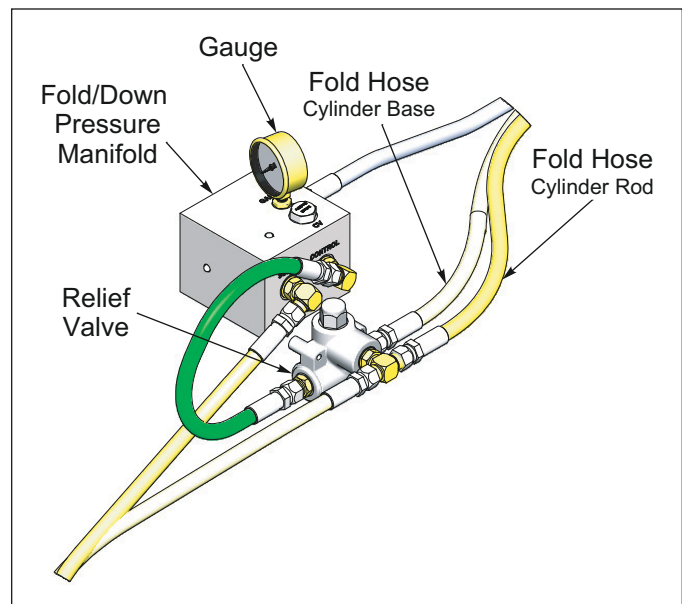

Figure 2-22: Fold/Down Pressure Valve



CAUTION

Restrictors are installed in both the rod and base end of wing fold cylinders to prevent uncontrolled dropping of wings. Removal of these restrictors, or improper installation can result in serious damage to the implement.

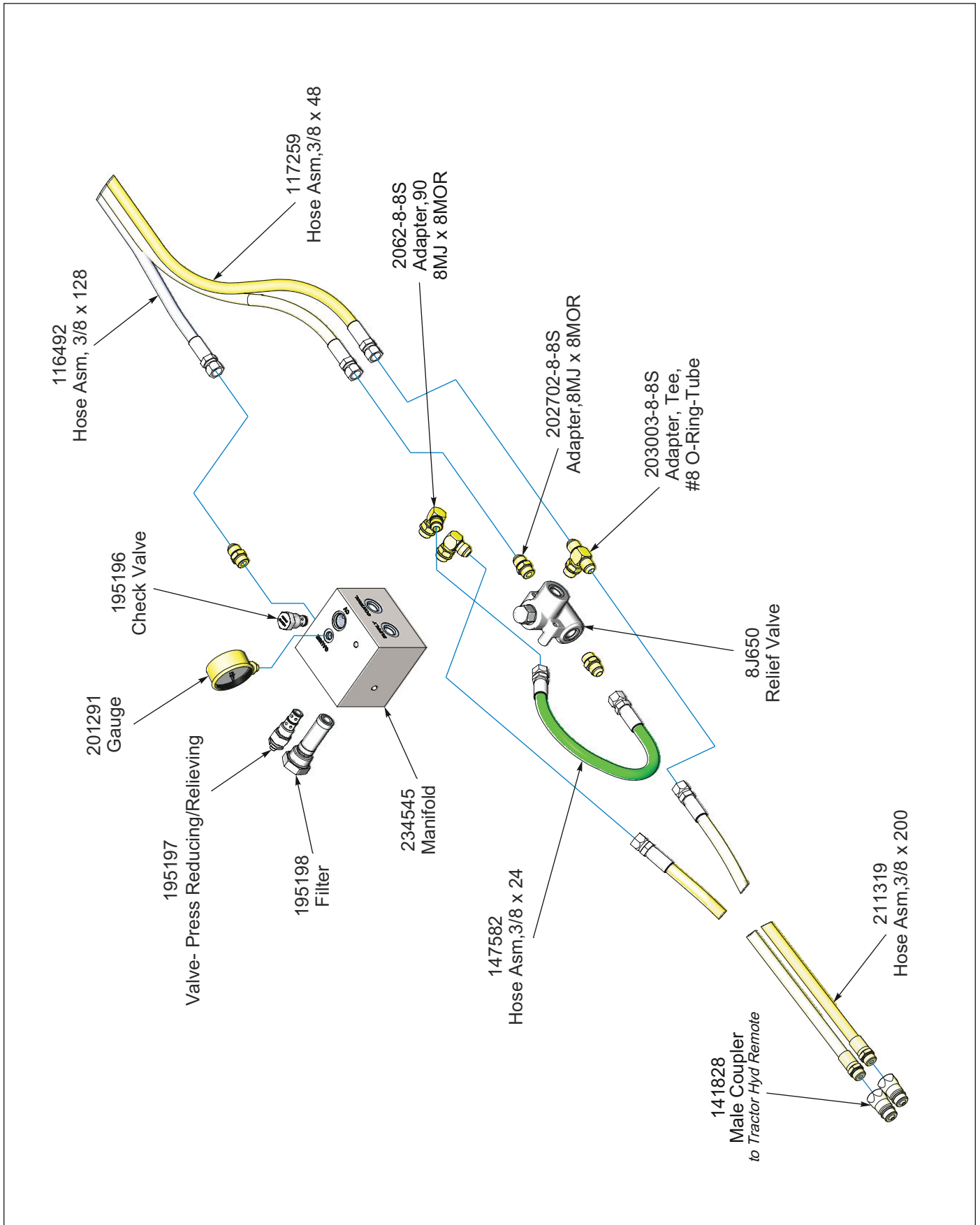

Figure 2-23: Down Pressure Valve

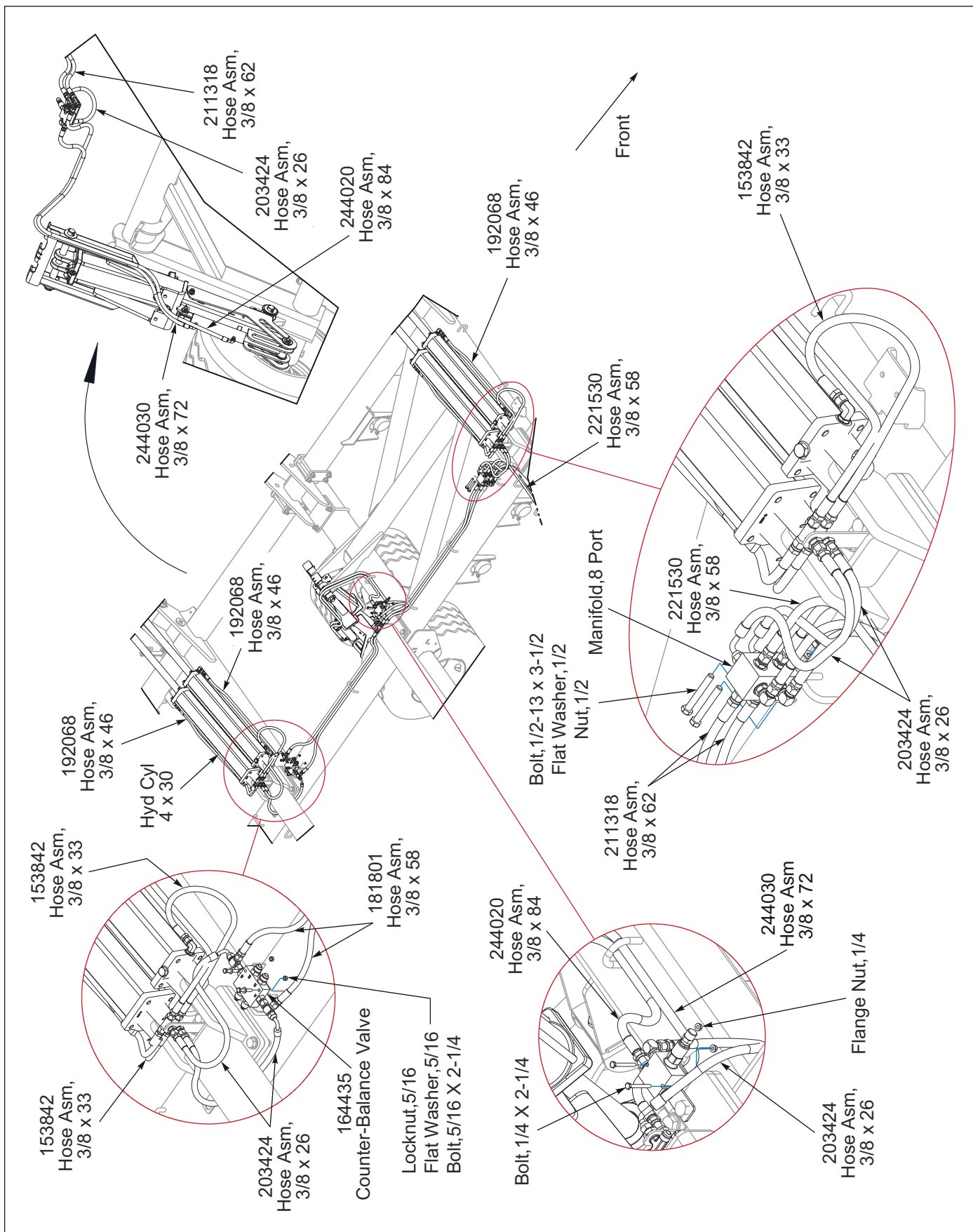

Figure 2-24: Fold Hydraulic Layout - Left Hand

Plumb Lift Circuit

1. Attach the Counter Balance Valve to the inside frame bracket with 5/16-18 x 2 Bolt, Flat Washer, Lockwasher and Nut, **See Figures 2-28 and 2-33.**
2. Install Counter Balance Valve fittings. **See Figure 2-34.**

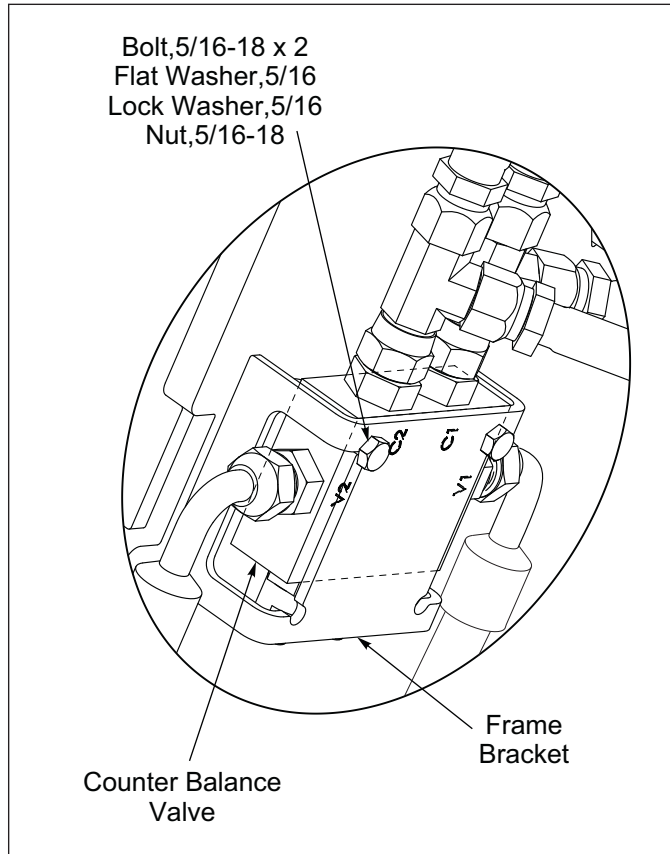

Figure 2-28: Counter Balance Valve

3. Attach Hoses to Counter Balance Valve. Route the Hoses to the right side of the Drawbar and clamp each set of system's hoses with hose clamps. Secure with Flat Washer under the head of 3/8-16 x 5 Bolt and Locknut. Continue routing the hoses to the front of the Drawbar up the Hose Holder Bracket. If not already done, install 3/8-16 x 5 Bolt onto Hose Holder Bracket with Hex Nut. Place the Hose Holder Clamp over the bolt and hoses. Secure with Hose Holder Wing Nut. **See Figures 2-9 and 2-33.**
4. Install the Lift Cylinders and Hitch Leveler 4 x 8 Cylinder fittings.



CAUTION

A Restrictor is used in the base end of the Hitch Leveling 4 x 16 Cylinder. Removal of this restrictor can cause uncontrolled movement of the front of the machine. Improper installation can result in serious damage to the implement.

5. Install Restrictor and Branch Tee into the base end and O-Ring Branch Tee into the rod end of the 4 x 16 cylinder. **See Figures 2-33 and 2-34.**
6. Install Lift Cylinder and Hitch Leveler Hoses.
7. Secure all hoses with tie wraps. Wrap the Lift Circuit System hoses near the Tractor Tips with blue hose wrap.

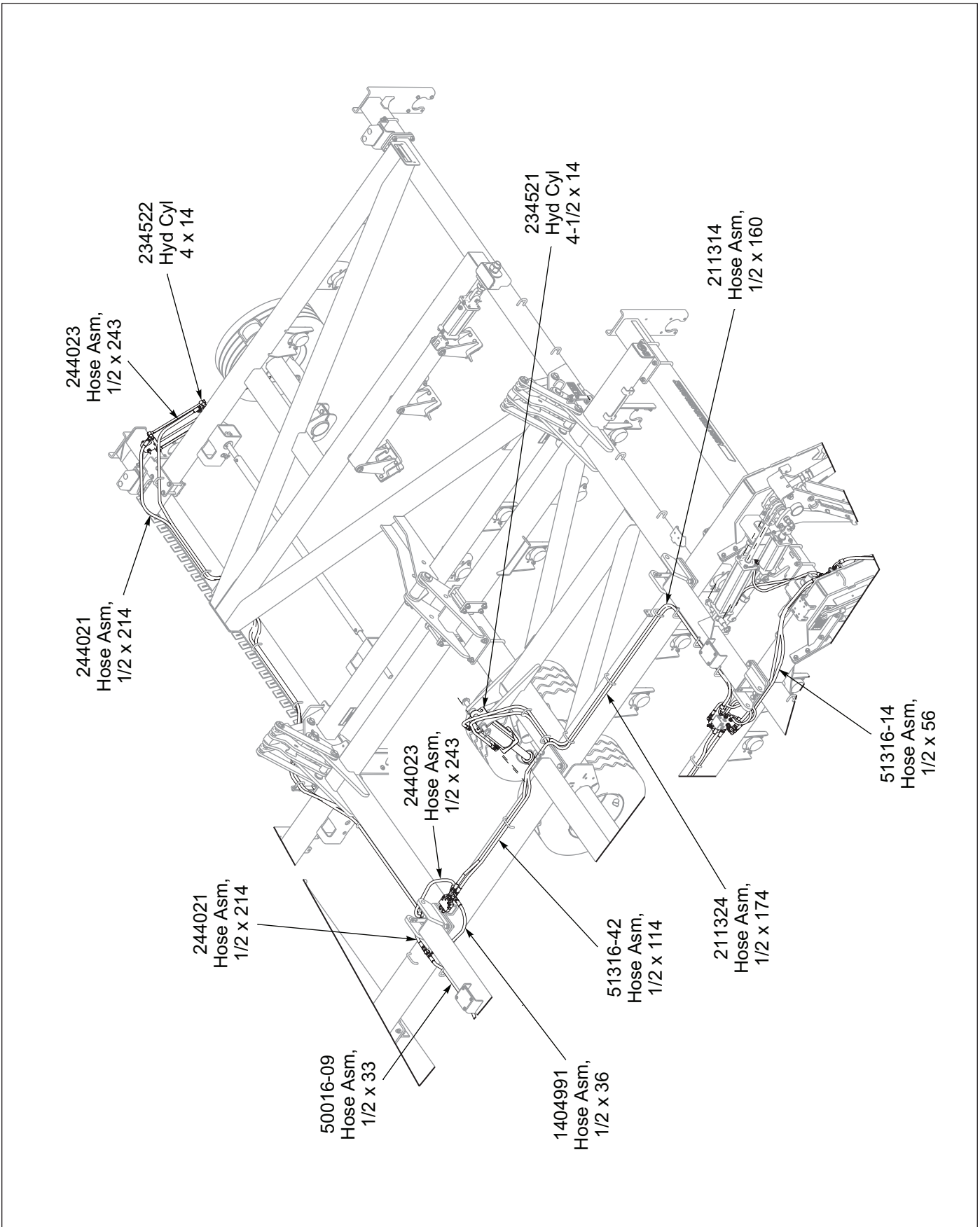

Figure 2-29: Hydraulic Lift Layout (Series Cylinders w/Wing Lift Wheels) (LH)

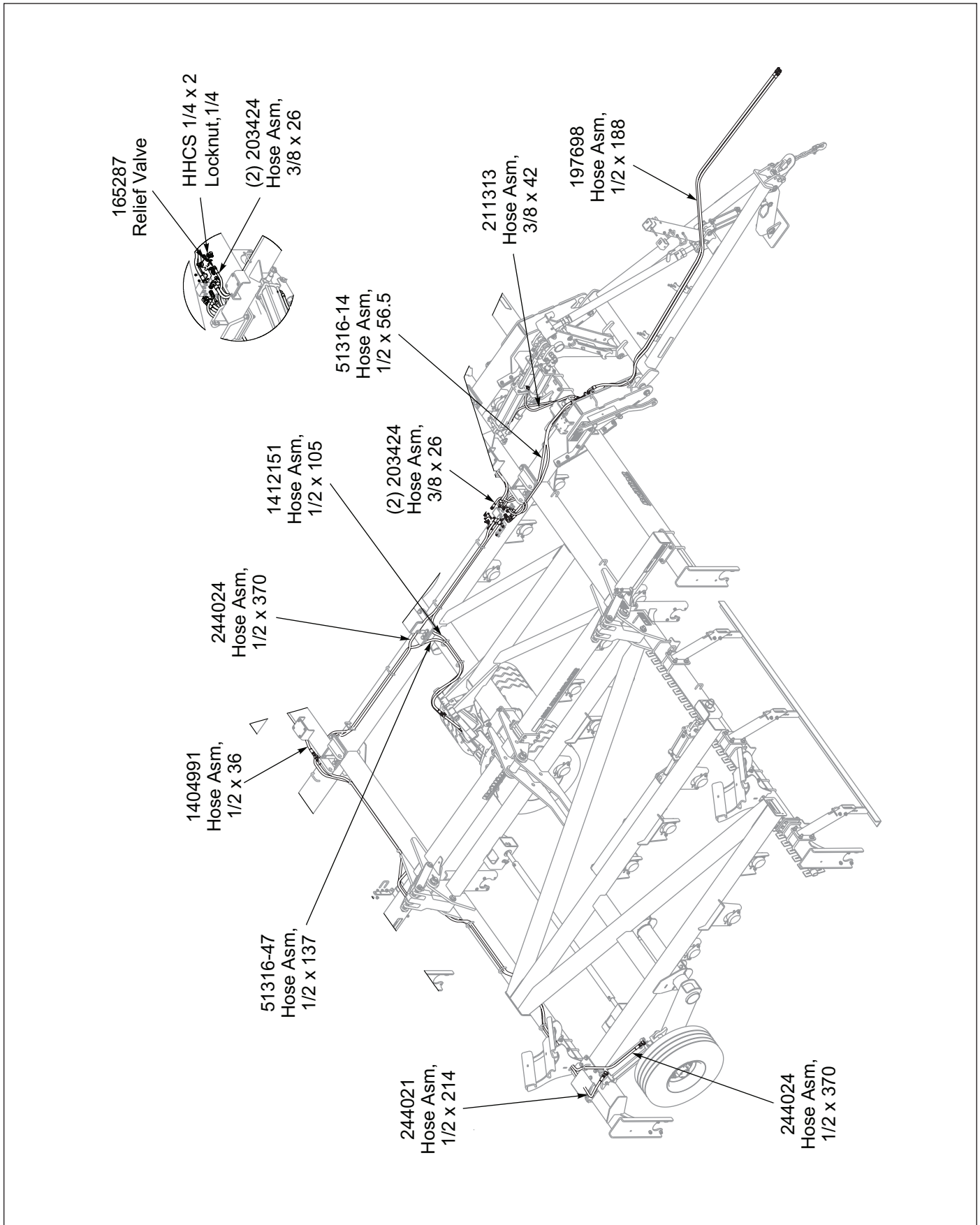

Figure 2-30: Hydraulic Lift Layout (Series Cylinders w/Wing Lift Wheels) (RH)

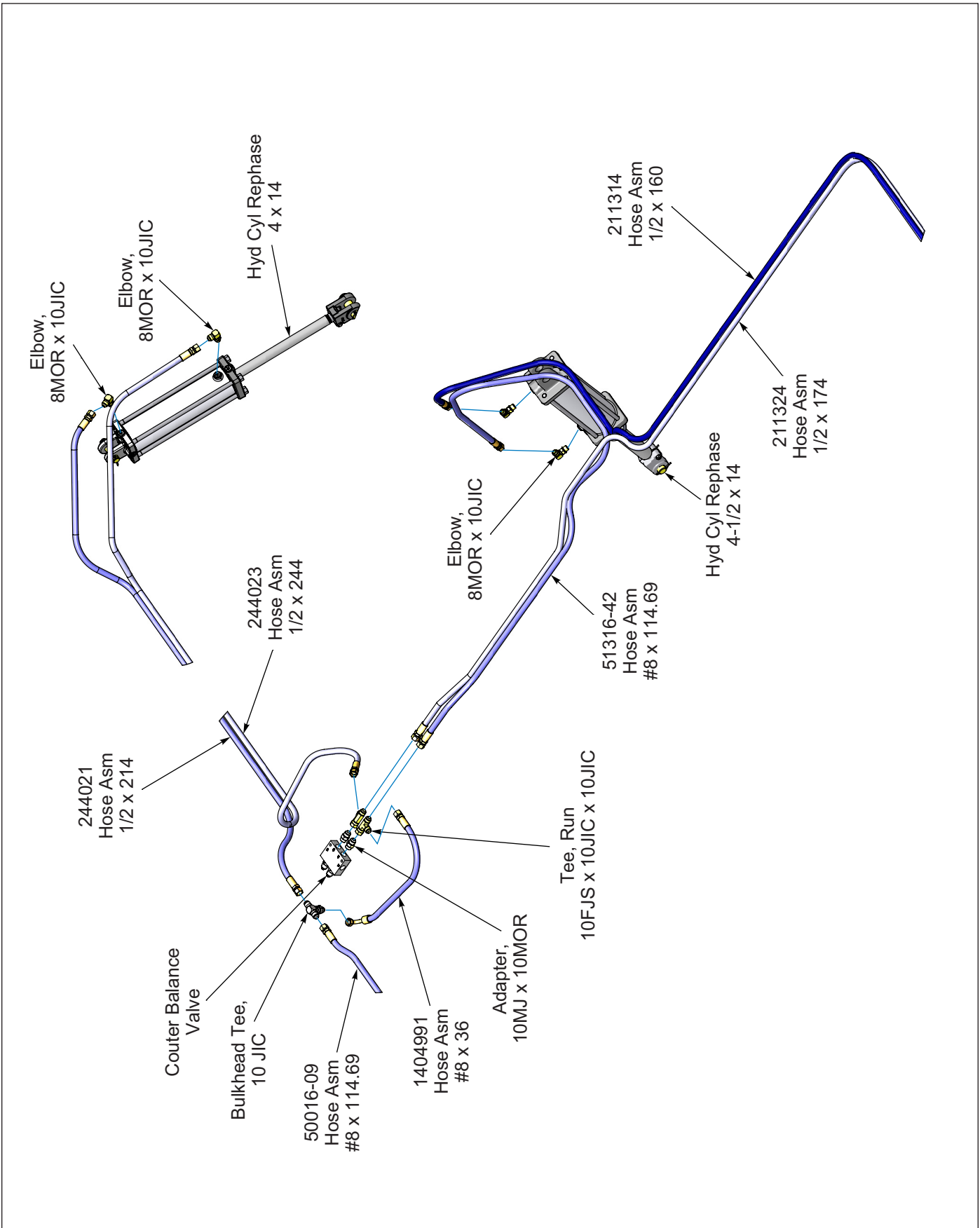

Figure 2-31: Hydraulic Lift Schematic (Series Cylinders w/ Wing Lift Wheels) (LH)

Purging the Hydraulic System

WARNING

Escaping hydraulic fluid can cause serious personnel injury. Relieve system pressure before repairing, adjusting, or disconnecting. Wear proper hand and eye protection when searching for leaks. Use cardboard instead of hands. See Figure 2-35. Keep all components (cylinders, hoses, fittings, etc.) in good repair.

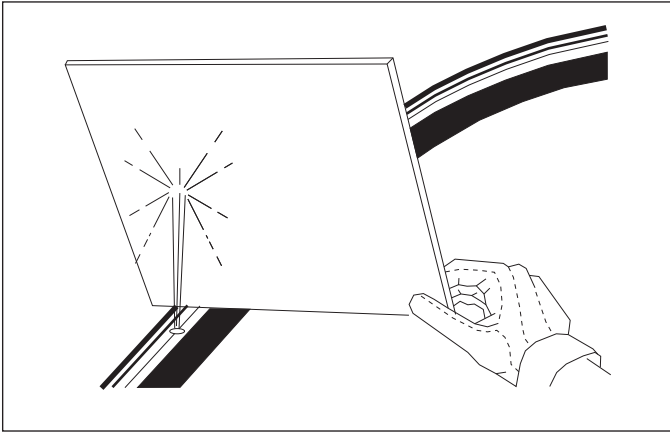

Figure 2-35: Hydraulic Leak Detection

The hydraulic system is not filled with oil and should be purged of air before transporting and field operations. Carefully hitch the Pulvi-Mulcher to the tractor and connect the hydraulic lift hoses. Check to make sure the tractor hydraulic reservoir is full of the manufacturer's recommended oil.

Purge the Lift Cylinders

NOTE

Lift Circuit must be purged after Wings are installed.

Slowly raise machine and continue to hold Hydraulic Lever until Lift and Leveling Cylinders are completely extended. Lift Cylinders are rephasing in extend. Hold Leveler in raise to purge Lift Cylinders.

Lower and raise unit completely extend and retract cylinders 5-6 times to purge air from the Lift Circuit. Do not loosen hoses/fittings. Recheck tractor reservoir oil level.

With machine raised (transport position), Lift Circuit requires 6.3 gallons of hydraulic oil. With machine lowered, requires 5.6 gallons of hydraulic oil.

Purge Fold Circuit

With Fold Cylinders disconnected from Wings and blocked up to allow for rod movement, connect Fold Circuit Hoses to tractor. Ensure tractor reservoir is full of manufacturer's recommended oil. Extend Fold Cylinders. Recheck tractor oil reservoir. Extend and retract Fold Cylinders 5-6 times or more if movement is not smooth or until air is purged from the circuit.

Fold Circuit requires 14 gallons of hydraulic oil in transport position. Wings unfolded, requires 17.7 gallons of hydraulic oil.

Center Frame Tooth Tube Installation

Verify Tooth Tube Bearings are positioned in the proper hole.

Bottom Hole: Roller with 24" Diameter Wheels. **See Figure 2-36.**

1. After marking the tubes for the shank locations, slide the 170" Tooth Tubes into the Tooth Tube Bearings. **See Figure 2-37.**
2. Position Tooth Tubes in the proper lateral position to the frame before continuing. **See Figure 2-38.**

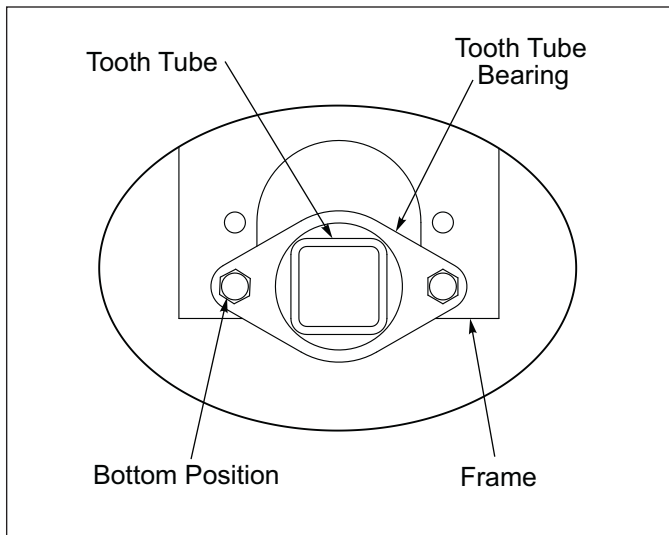

Figure 2-36: Tooth Tube Bearing Position for Roller with 24" Wheels

Center Frame Shank Mounting Dimensions

NOTE

Do Not mount the Shanks to the Tubes at this time.

Mark the tubes for Shank locations prior to installing the tubes.

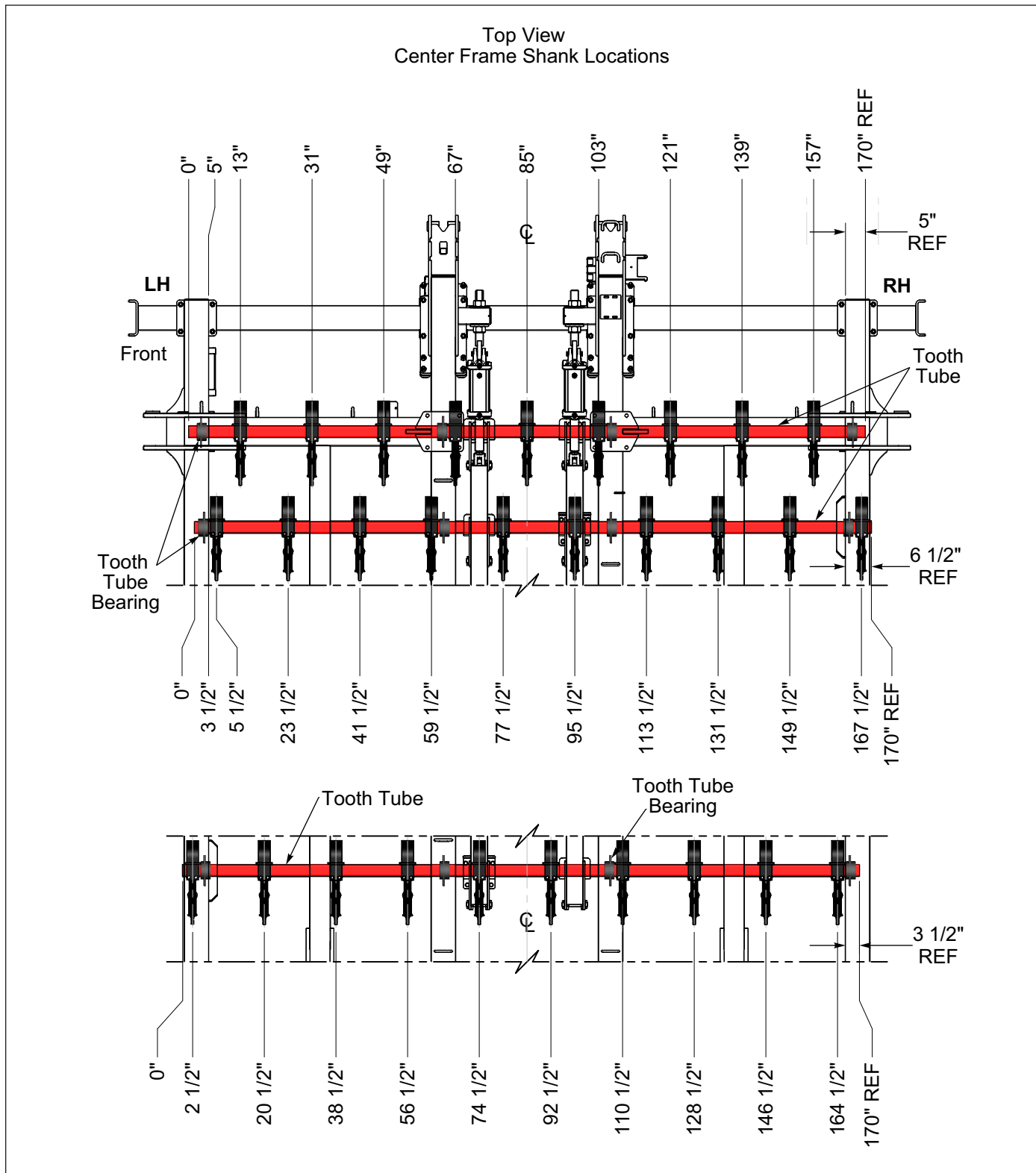

Figure 2-37: Center Frame Shank Mounting Dimensions

Center Frame Tooth Control Brackets Mounting Dimensions

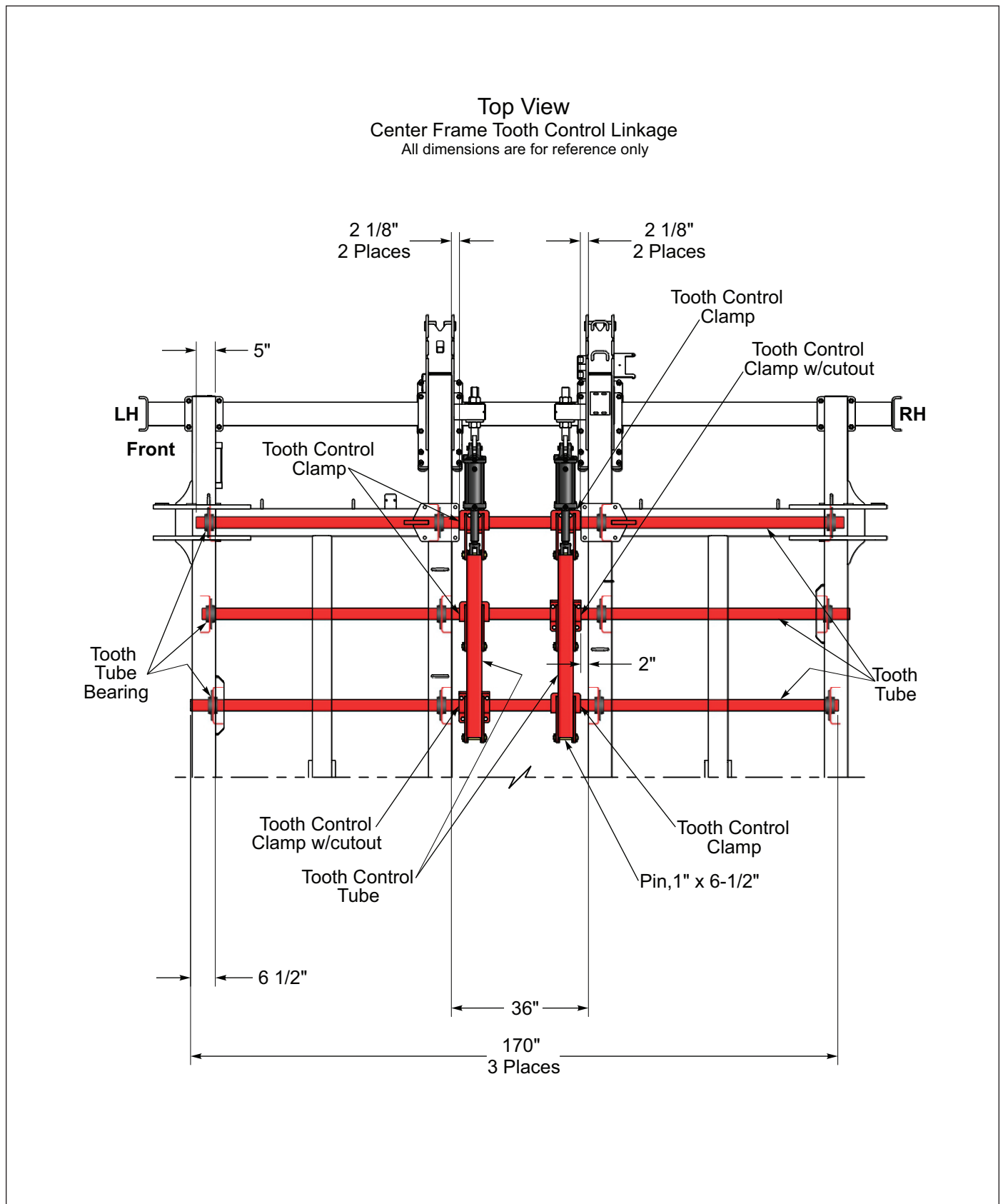

Figure 2-38: Center Frame Tooth Control Brackets Mounting Dimensions

Center Frame Tooth Control Installation

Left Side

1. Attach a Tooth Control Bracket on the top of the left Front Tooth Tube by sliding a Clamp Plate into the Tooth Control Bracket Slot and under the Tooth Tube. Secure with 5/8-11 x 5 Bolts and Locknuts. **Do Not** tighten at this time. **See Figures 2-38 and 2-39.**
2. Lay the Cylinder Rod Clevis between the Tooth Control Clamp Lugs. Position the Tooth Control Tube over the top of the Cylinder Rod Clevis and between the Tooth Control Bracket Lugs and insert a 1 x 6-1/2 Pin. Place a 1" Flat Washer on each side of the Pin against the Tooth Control Bracket. Secure with 5/16 x 2 Roll Pins.
3. Position a Tooth Control Clamp w/cutout on top of the left Rear Tooth Tube while straddling the Tooth Control Tube. Insert 1 x 6-1/2 Pins. Place a 1" Flat Washer on each side of the Pin against the Tooth Control Clamp and secure with 5/16 x 2 Roll Pins. Tooth Control Clamps should be aligned with each other. Attach Tooth Control Clamp on the Tooth Tube with two 5/8-11 x 5 Bolts and two 5/8-11 x 2 Bolts and Locknuts.
4. Position a Tooth Control Bracket on top of the left Middle Tooth Tube while straddling the Tooth Control Tube. Insert 1 x 6-1/2 Pins. Place a 1" Flat Washer on each side of the Pin against the Tooth Control Bracket and secure with 5/16 x 2 Roll Pins. Attach Tooth Control Clamps on Tooth Tube by sliding a Clamp Plate into the Tooth Control Bracket Slot and under the Tooth Tube. Secure with 5/8-11 x 5 Bolts and Locknuts.

Right Side

1. Attach a Tooth Control Bracket on the top of the right Front Tooth Tube by sliding a Clamp Plate into the Tooth Control Bracket Slot and under the Tooth Tube. Secure with 5/8-11 x 5 Bolts and Locknuts, **Do Not** tighten at this time. **See Figures 2-38 and 2-39.**
2. Lay the Cylinder Rod Clevis between the Tooth Control Bracket Lugs. Position the Tooth Control Tube over the top of the Cylinder Rod Clevis and between the Tooth Control Bracket Lugs and insert a 1 x 6-1/2 Pin. Place a 1" Flat Washer on each side of the Pin against the Tooth Control Bracket. Secure with 5/16 x 2 Roll Pins.
3. Position a Tooth Control Bracket on top of the right Rear Tooth Tube while straddling the Tooth Control Tube. Insert 1 x 6-1/2 Pins. Place a 1" Flat Washer on each side of the Pin against the Tooth Control Bracket and secure with 5/16 x 2 Roll Pins. Attach Tooth

Control Brackets on Tooth Tube by sliding a Clamp Plate into the Tooth Control Bracket Slot and under the Tooth Tube. Secure with 5/8-11 x 5 Bolts and Locknuts.

4. Position a Tooth Control Clamp w/cutout on top of the right Middle Tooth Tube while straddling the Tooth Control Tube. Insert 1 x 6-1/2 Pins. Place a 1" Flat Washer on each side of the Pin against the Tooth Control Clamp and secure with 5/16 x 2 Roll Pins. Tooth Control Clamps should be aligned with each other. Attach Tooth Control Clamp on the Tooth Tube with two 5/8-11 x 5 Bolts and two 5/8-11 x 2 Bolts and Locknuts.

Ensure that both linkages don't bind and the Tooth Control Clamps and the Tooth Tubes are positioned correctly. **See Figure 2-39.** Tighten the Bolts and Nuts at this time.

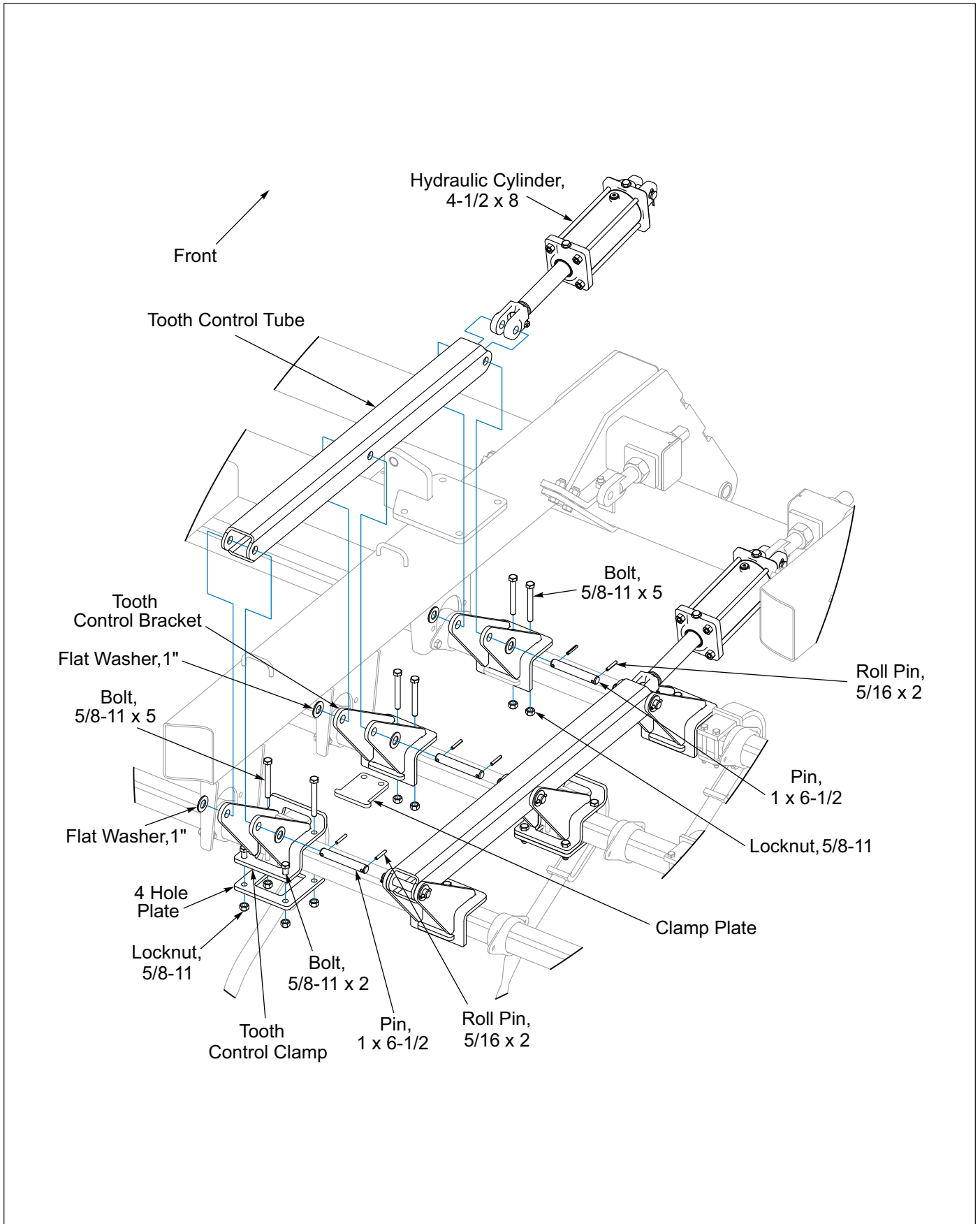

Figure 2-39: Center Frame Tooth Control Linkage

Shank Installation

1. Engage Transport Locks

NOTE

It is easier to bolt the points to the shanks before mounting them on the machine.

NOTE

*If machine requires Optional Front Scrapers. Lower the machine on a level surface and install scrapers before installing shanks. See scraper section on **Page 2-85**. Front installation is similar to rear. It is easier to install shanks while machine is raised.*

2. Assemble Points to Shanks as shown in **Figure 2-40**.
3. Mount the Shanks to the Tooth Control Tubes using two 1/2-13 x 5 Bolts and Locknut. **See Figure 2-37** for Center Shank Mounting Dimensions.

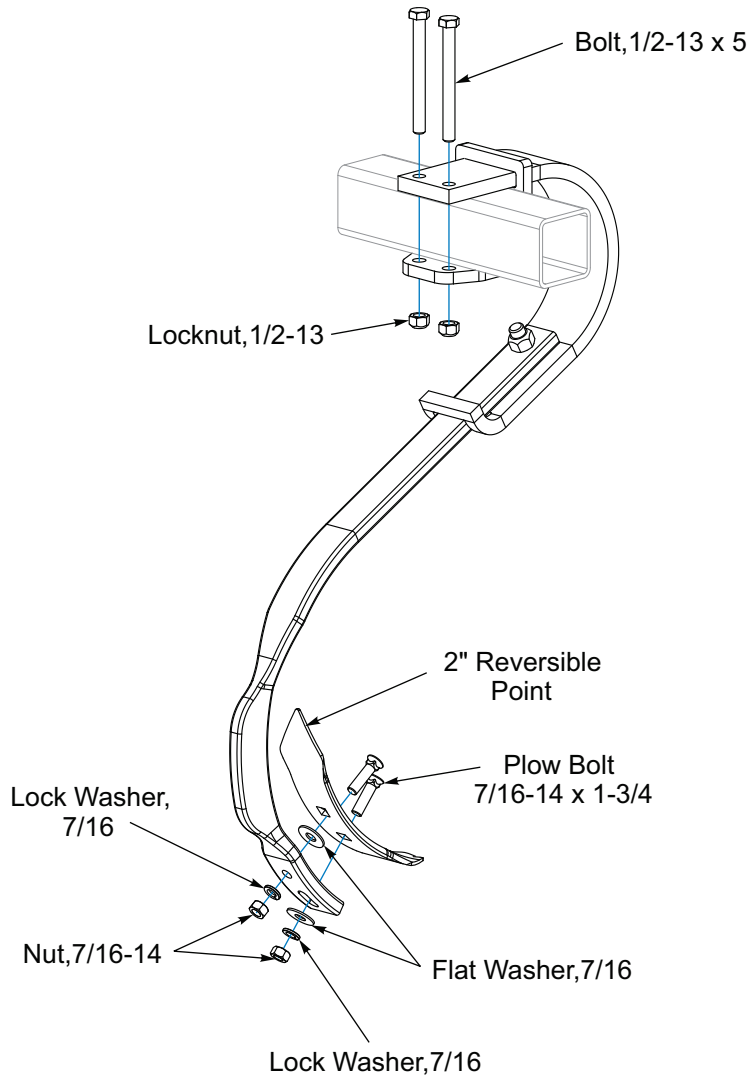

Figure 2-40: Shank Installation

Shank Depth Control Installation

1. If not already done, install Limit Valve, Slide Pad and Depth Stop Guide to Limit Valve Mount located at the front of the left side frame cross tube with 5/16-18 x 5-1/2 Bolts and Locknuts. **See Figure 2-41.**
2. Attach the Depth Stop Clamp on the top of the Middle Tooth Tube by sliding a Clamp Plate into the Depth Stop Clamp Slot and under the Tooth Tube. Assemble 5/8-11 x 5 Bolts and Locknuts, **Do Not** tighten at this time.

3. Slide the Depth Stop Assembly through the Depth Stop Guide to the Depth Stop Clamp. Position the Depth Stop Assembly over the Depth Stop Clamp Lug and align the Top hole of the Depth Stop Clamp for machines with the 24" Roller Wheels. Insert and secure with 5/8-11 x 2-3/4 Bolt and Flanged Locknut. **See Figure 2-42.**
4. Ensure that the Depth Stop Clamp is positioned correctly and that the Depth Stop Assembly moves freely when turning the handle.
5. Tighten the Depth Stop Clamp Bolts at this time.

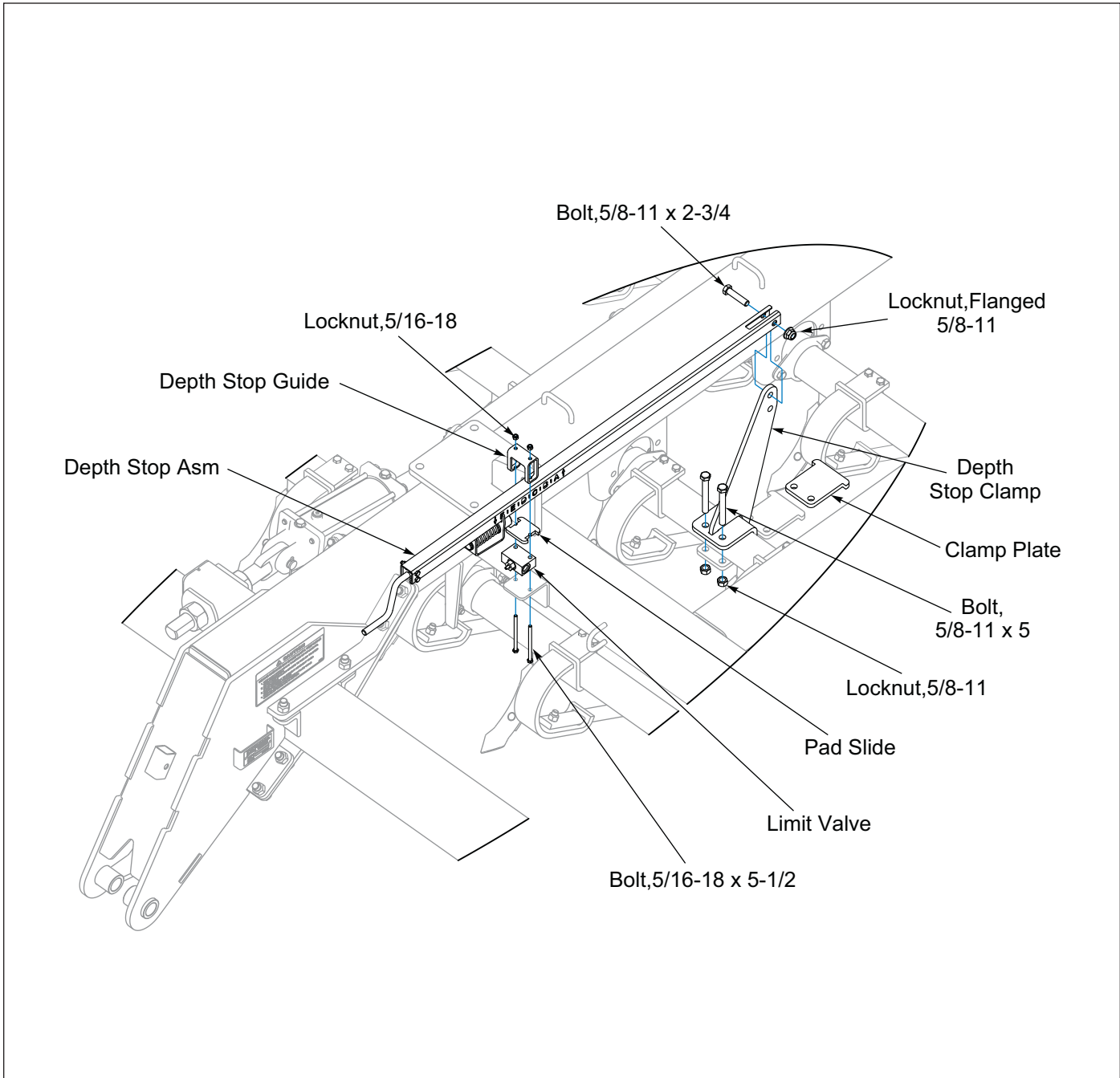

Figure 2-41: Shank Depth Control Installation

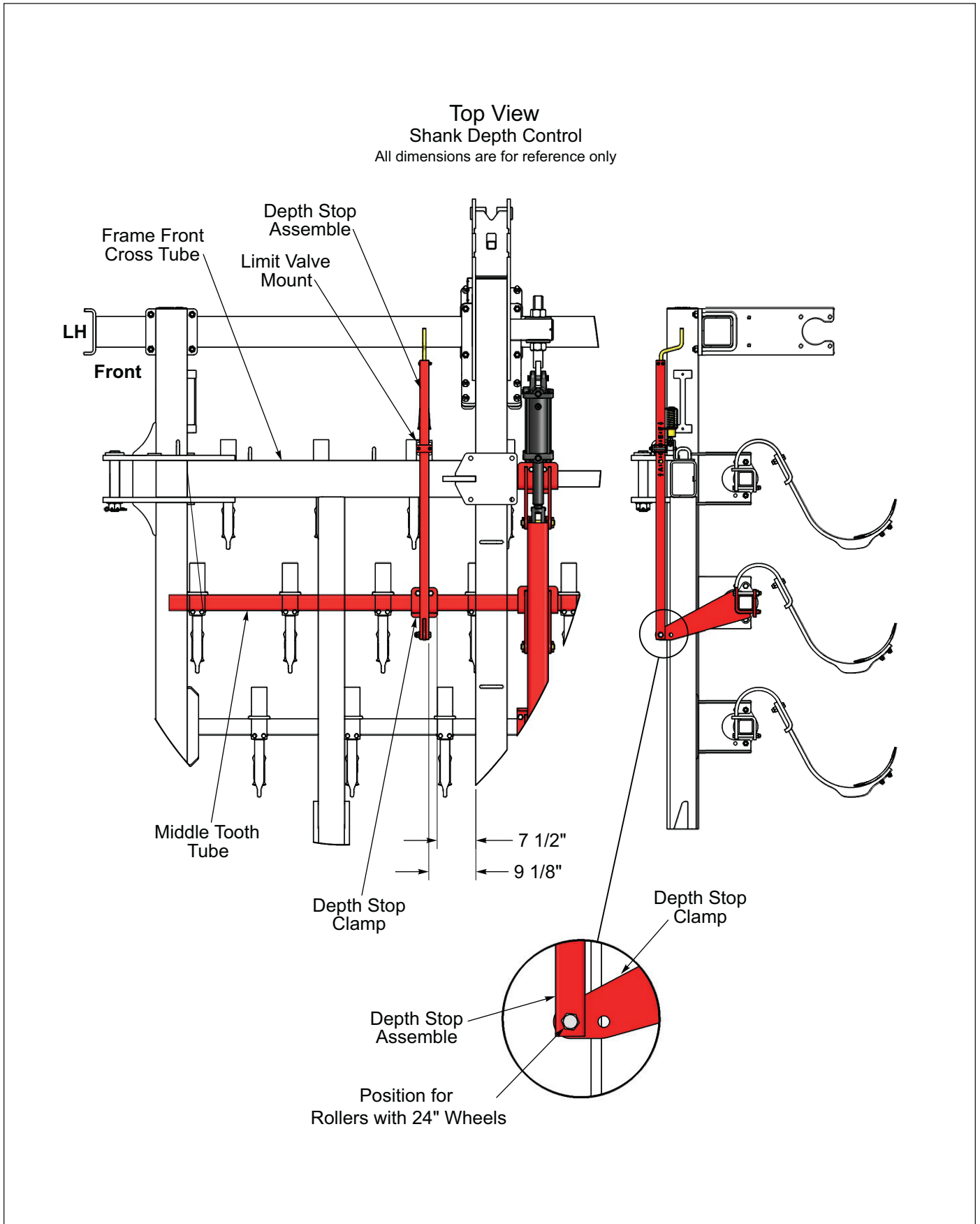

Figure 2-42: Shank Depth Control Installation Dimensions

Center Frame 2-Row Harrow Installation

1. Remove 1 x 7-5/16 Pin from each Frame Adjuster Mount located on the inside of the Outer Frame Tube. Insert a Harrow Adjustment Tube into each Frame Adjuster Mount and re-insert 1 x 7-5/16 Pin in the bottom hole. Secure with 3/16 Hair Pin Cotter. **See Figure 2-43.**
2. The 2-Bar Harrow comes factory assembled. Lift Harrow Assembly and slide the Harrow 3 x 3 Tube into the cut-out portion of the Harrow Adjustment Tube and insert a 1/2-13 U-Bolt on each side. **See Figures 2-43 and 2-44.** Check Harrow position in relation to the Frame and secure with Flat Washer and Locknut.
3. Install a 1/2-13 x 5 Bolt and Locknut into the top hole of each Harrow Adjustment Tube.
4. Remove from one end of the Frame Adjuster Mount, the Harrow Height Adjuster Handle Tube. Slide the Harrow Adjuster Tube onto the installed Harrow Height Adjuster Handle Tube. Re-install the removed Harrow Height Adjuster Handle Tube and Roll Pin. Secure Harrow Adjuster Tube with 3/8-16 x 2-3/4 Bolts, Flat Washers and Locknuts.

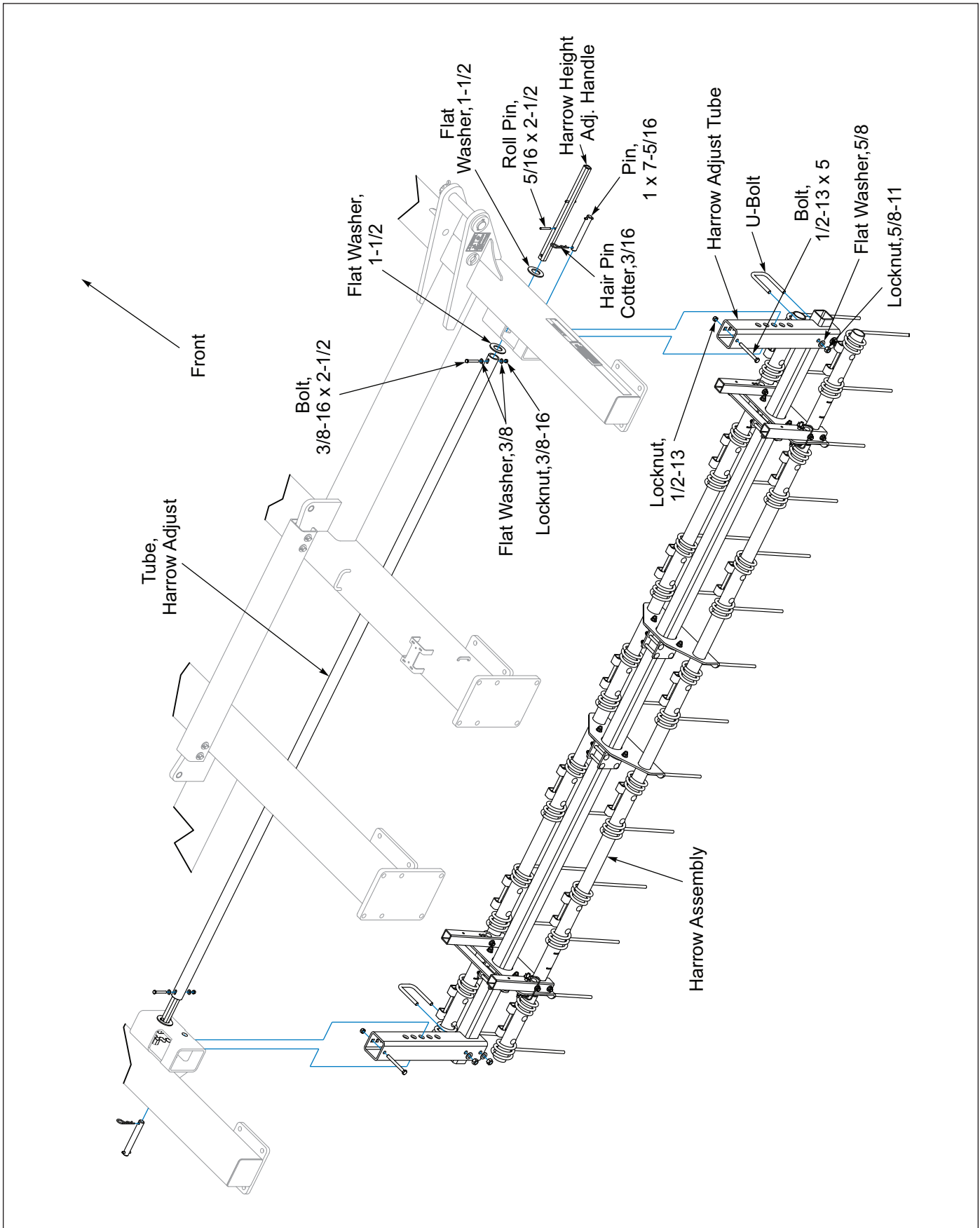

Figure 2-43: Center Frame 2-Row Harrow Installation

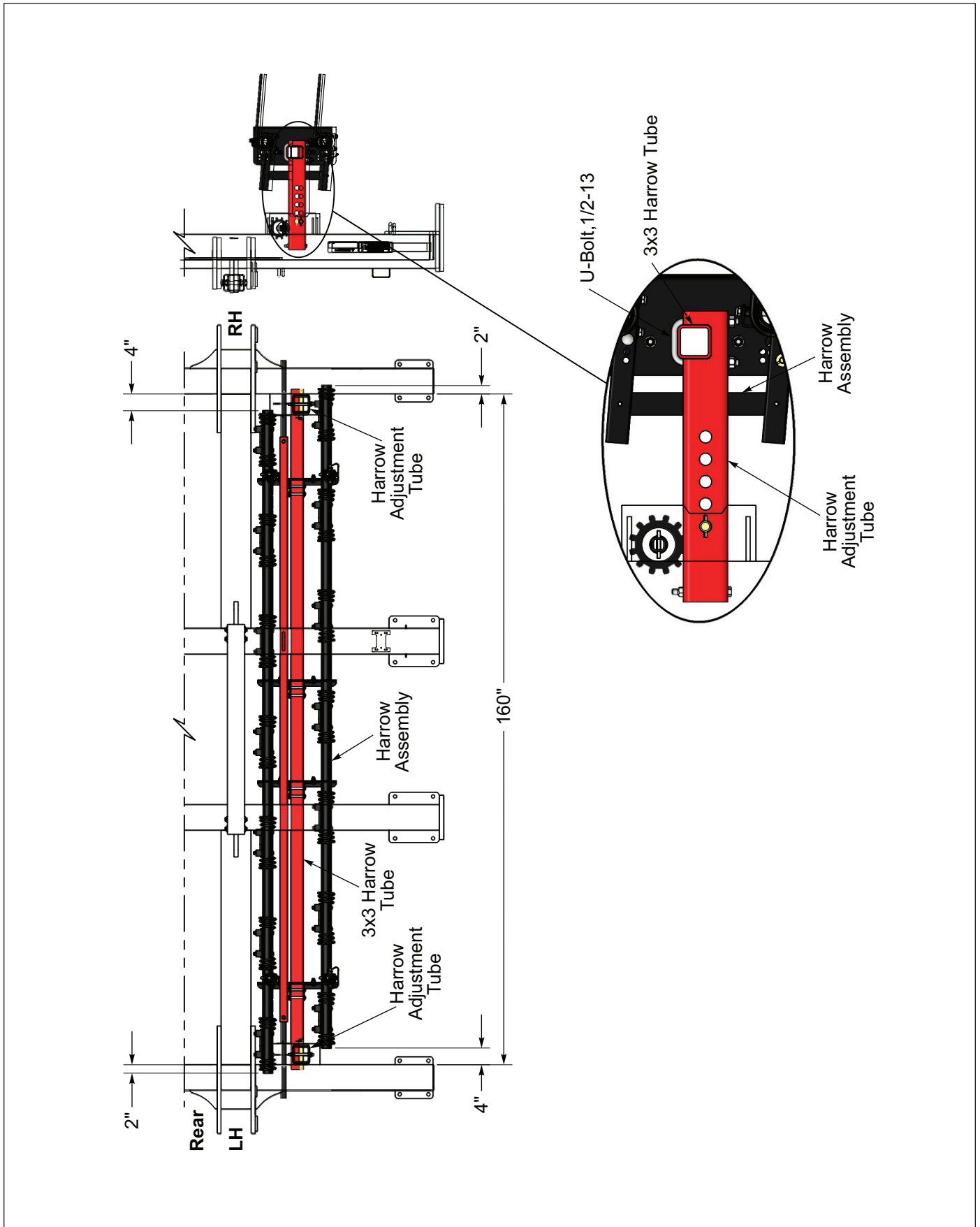

Figure 2-44: Center Frame 2-Row Harrow Dimensions

LED Warning Lamp Installation

NOTE

Be sure when assembling Lamps onto Bracket that the wires are not pinched when tightening hardware.

1. Attach the Light Brackets onto the Rear Roller Frame Tube with 5/8-11 U-Bolts and Flanged Locknuts. See **Figures 2-47 and 2-48.**
2. Assemble the Amber LED Lamps and Reflector Assemblies with the cutout and the yellow reflective decal facing the front of the machine onto the outer Light Brackets by placing a Flat Washer under the head of the 1/4-20 x 1-3/4 Bolts and inserting the bolt through the lamp. Secure with Locknuts. Assemble the Red LED Lamps with the lens facing the rear of the machine and Reflector Assemblies onto the inner Light Brackets in the same manner.
3. Attach the Flasher Control Module to the Module Bracket on the RH Frame Inner rear tube using two 1/4-20 x 1-1/2 Bolts and Locknuts. See **Figure 2-45.**

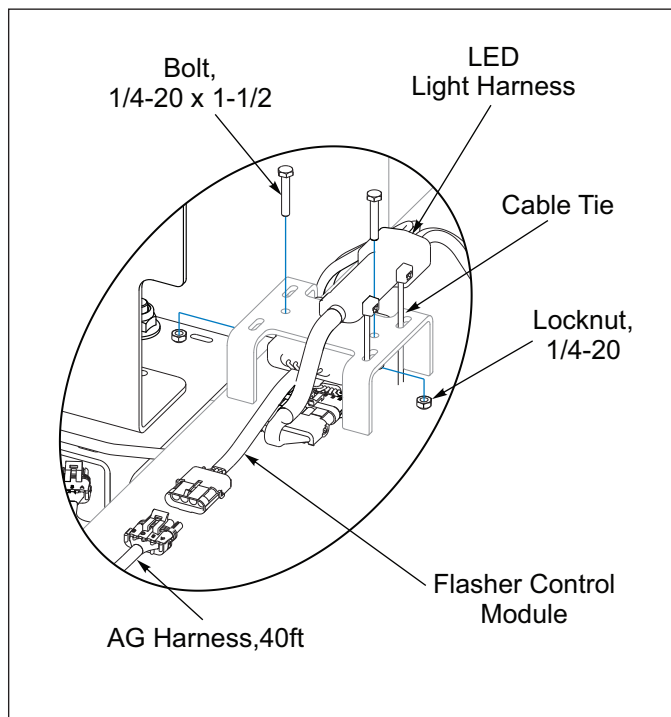

Figure 2-45: Flasher Control Module

4. Lay out the Lamp Harness, noting that the connectors marked with Green Tape is Right Side and Yellow Tape is Left Side. Plug the Lamp Harness into the Flasher Control Module.
5. Route Green Tape cords along the right side of the Rear Roller Frame. Plug the 3-Prong Cord into the Red Lamp. Plug the 2-Prong Cord into the Amber Lamp.

6. Repeat for the Left Side (Yellow Tape).
7. Plug the 7-Pin Harness 4-Pin Weather pack plug into the Flasher Control Module, then route the harness along the inner RH Frame Tube, down the Drawbar and through the hose holder following the hydraulic hoses.
8. Bundle and secure excess cord to the Light Bracket with Tie Straps. Secure cords along frame using Tie Straps.

NOTE

All wires must be firmly attached to machine frame members so they do not sag or become torn loose by field debris.

SMV Sign Installation

Attach the SMV Mount to the center frame using 5/8-11 U-bolt and Flanged Locknuts. Attach SMV sign to mount using two 5/16-18 x 1 Bolts, Flat Washers and Locknuts. See **Figure 2-46.**

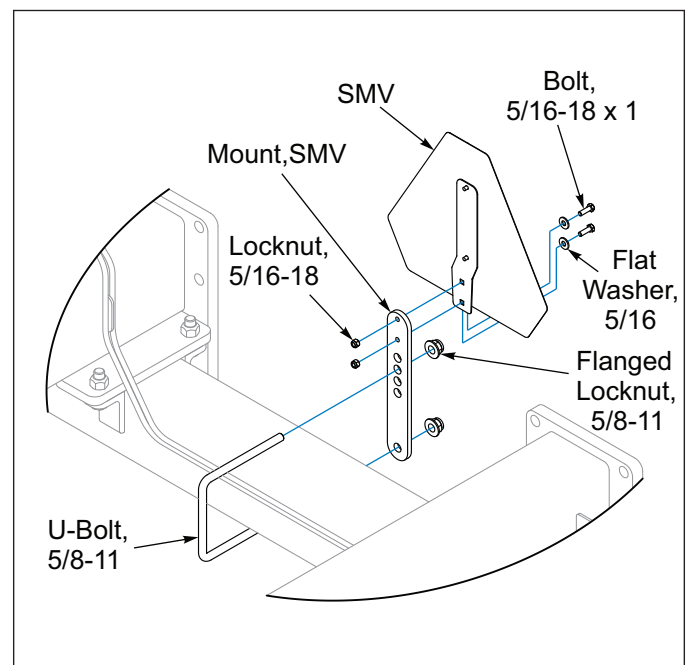

Figure 2-46: SMV Sign Installation

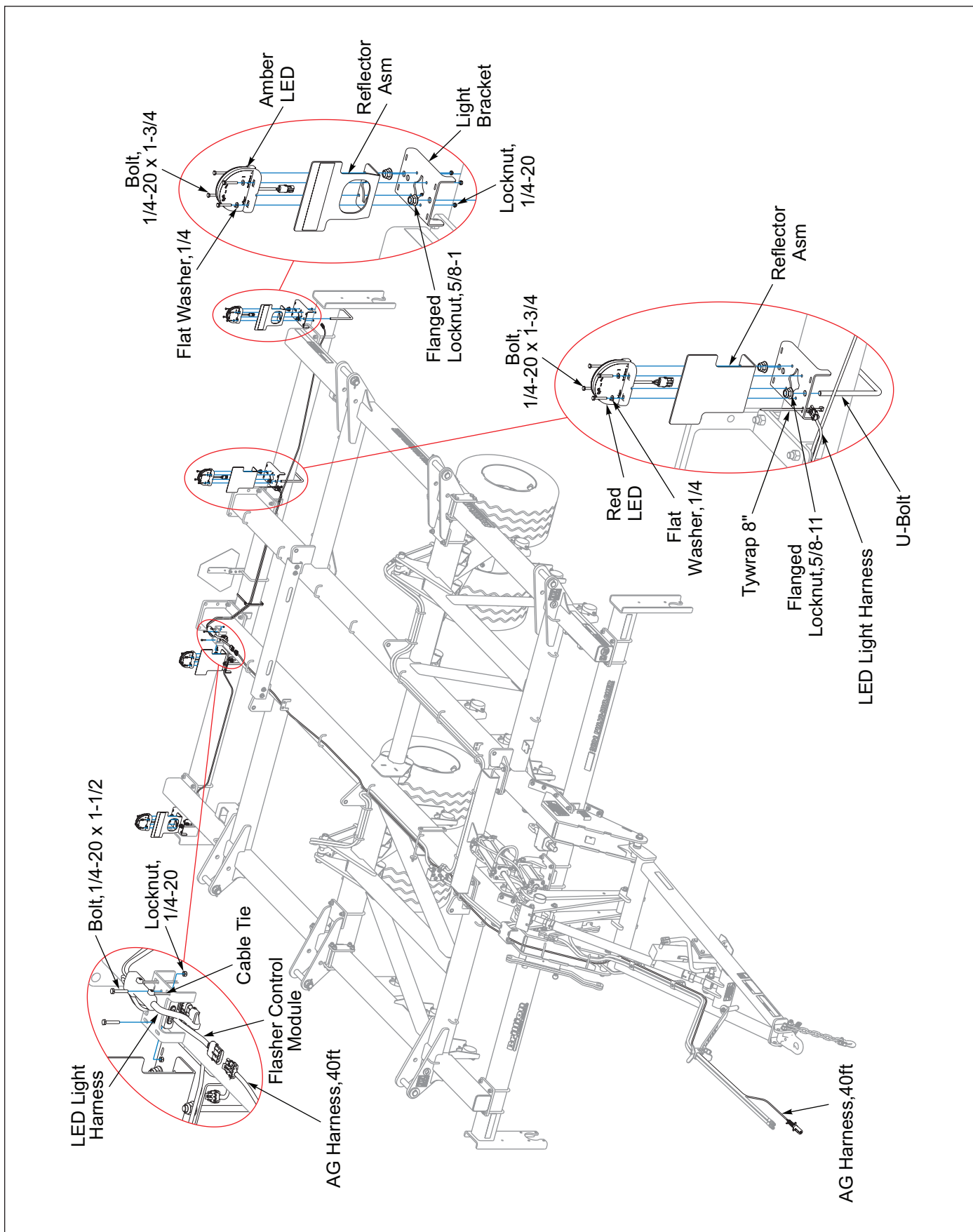

Figure 2-47: Electrical Layout

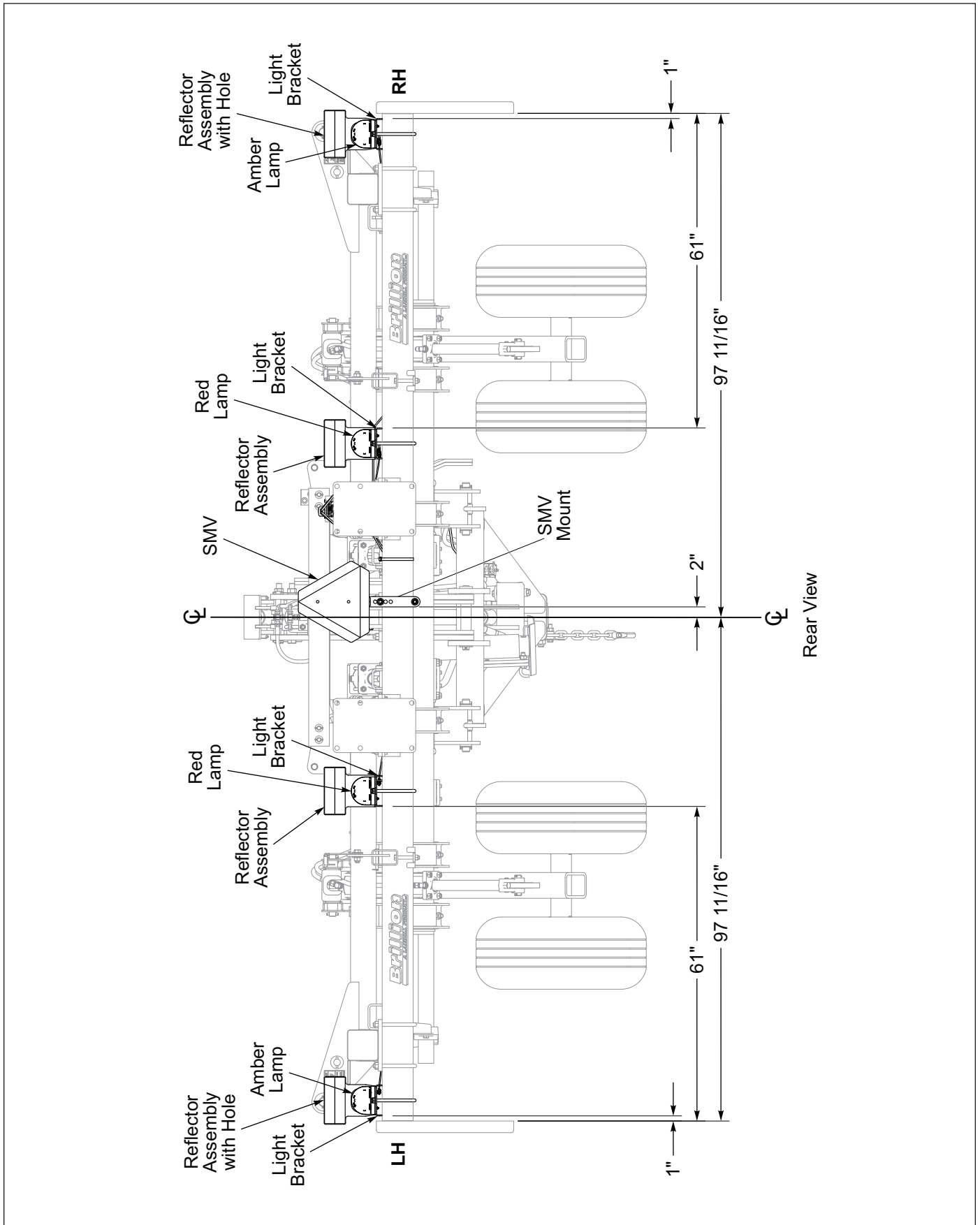

Figure 2-48: Electrical Dimensions

Bearing Hanger and Wing Rest Installation

1. Assemble a Rubber Bumper onto each Wing Rest Bracket with 1/2-13 x 3-1/2 Bolts, Flat Washers and Locknuts. See Figures 2-49 and 2-50.

2. Attach Bearing Hanger to Wing Frame on the Bottom with 3/4-10 x 2-1/4 Bolts and Locknuts. **Do Not** Tighten at this Time. Place the Wing Rest Bracket over the outside of the Bearing Hanger. Assemble the Wing Rest Bracket and Bearing Hanger onto the Wing Frame with 3/4-10 X 2-3/4 Bolts and Locknuts. Tighten the 3/4-10 Bolts at this time.
3. Secure the end of the Wing Rest to the Wing Frame with 5/8-11 U-Bolts and Flanged Locknuts.

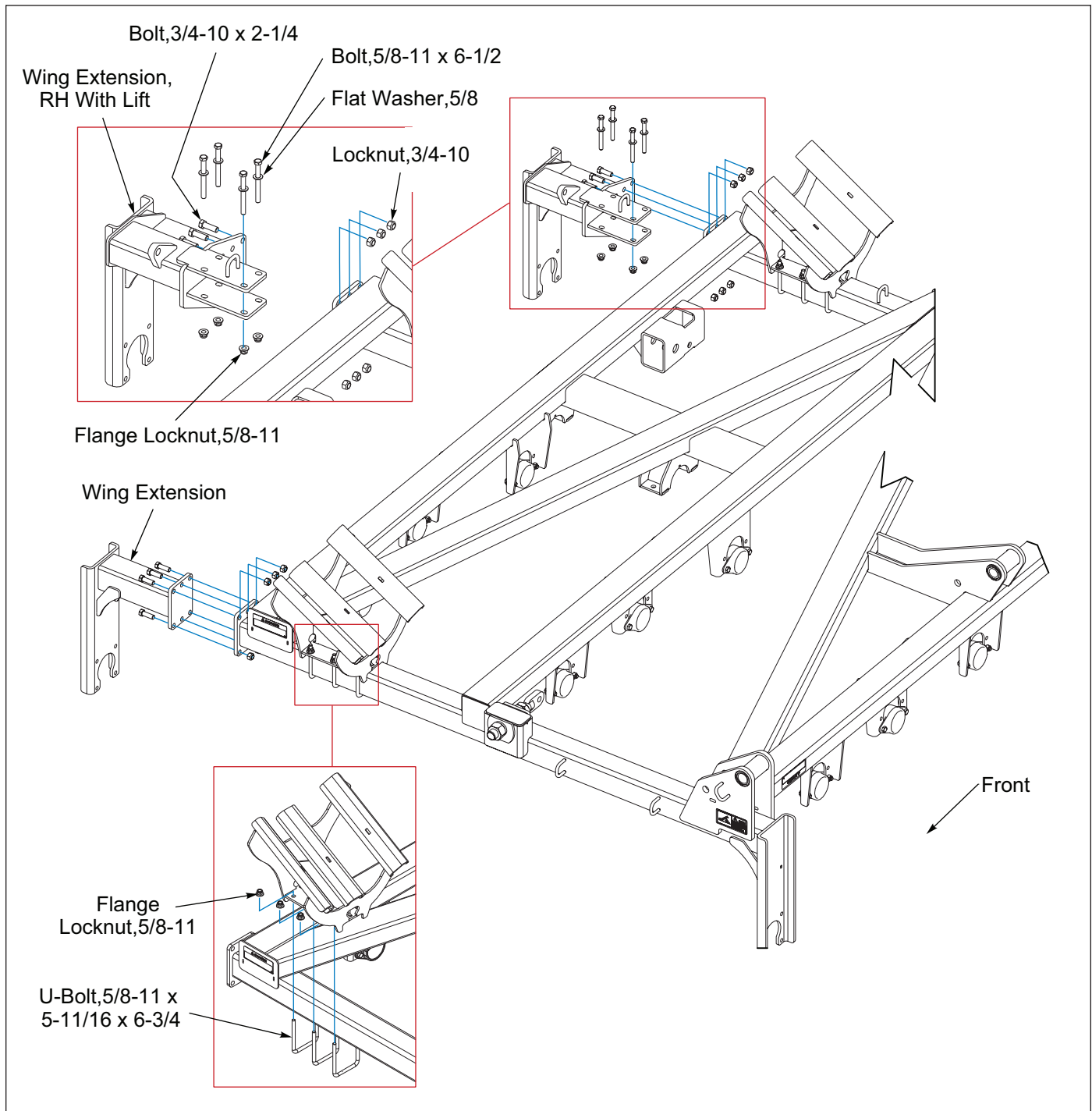

Figure 2-49: Right Wing Rest and Bearing Hanger

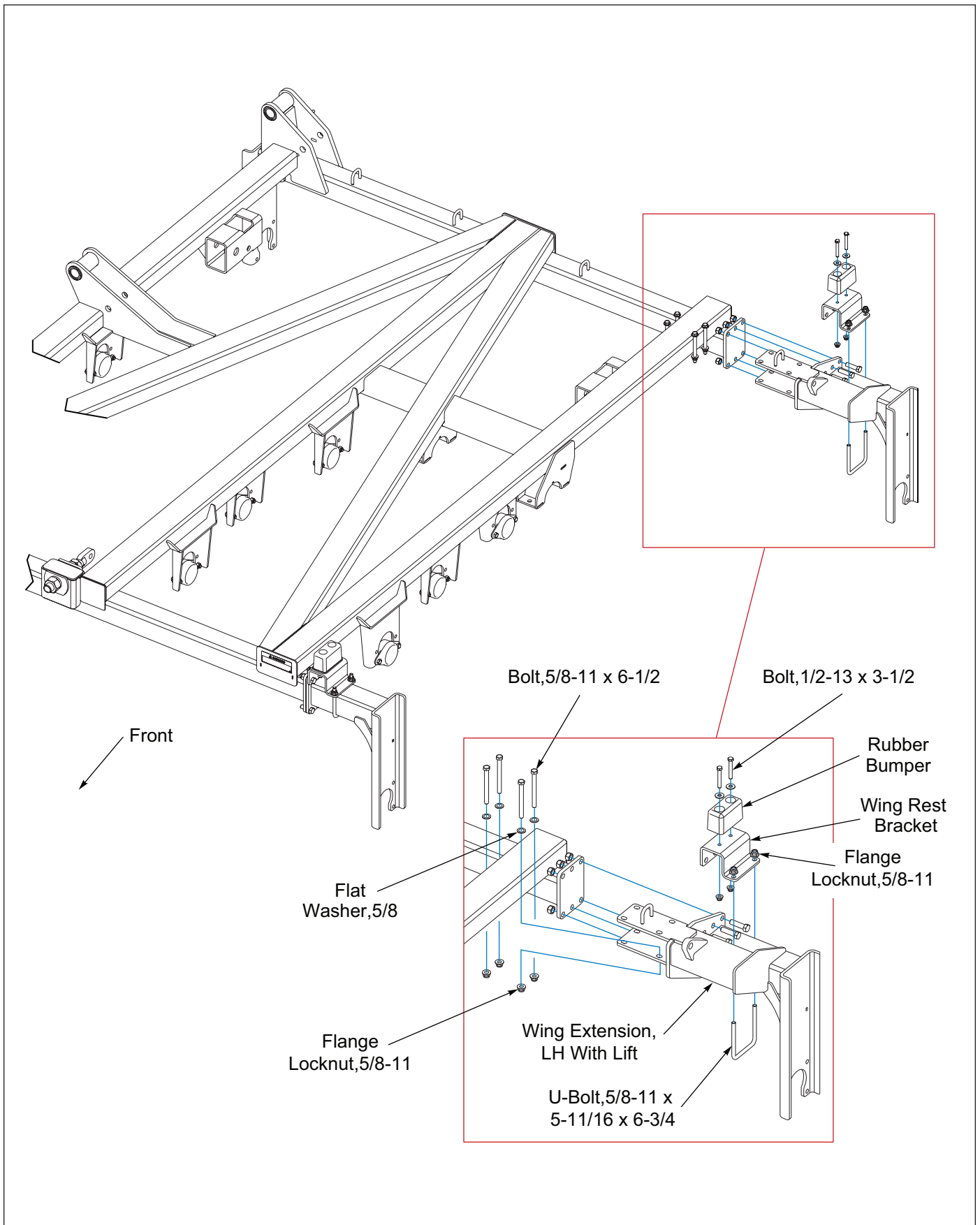

Figure 2-50: Left Right Wing Rest and Bearing Hanger

Wing to Frame Installation

1. Insert two Flange Bearings into each Wing Frame Hinge. Remove existing Pin and Hardware from Center Frame Hinge Lug. Position the Wing Frame Hinges between the Center Frame Hinge Lugs and align the holes. Once positioned place one 1-3/4 x 3 x 10ga Thrust Washer between each Wing Frame Hinge and Center Frame Hinge Lug on the front and rear hinges. (No Thrust Washers on middle hinges.) Thrust Washer should be against the Flange Bearing. Secure by Re-installing Pin and Hardware. See Figure 2-55.

IMPORTANT

At this Step, make sure to Plumb and Purge the Fold Circuit before proceeding with Fold Linkage.

2. Place the Welded Hinge Link End between the Center Frame Hinge Plates. See Figure 2-55. Slide a 1-1/4 x 2-1/2 x 12ga Thrust Washer between the Hinge Link and the Center Frame Hinge Plates. Insert 1-1/4 x 13 Pin into the side of the Center Frame Hinge Plate. See Figure . Place two Flat Washer on each end of the Pin. Secure with 5/16 x 2 Roll Pin.

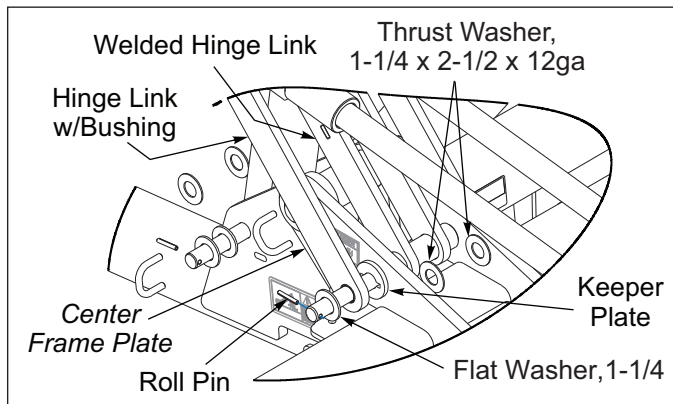

Figure 2-51: Center Frame Hinge Assembly

3. Place the Fold Link End with the bushing between the Wing Hinge Frame Plates. Slide a 1-1/4 x 2-1/2 x 12ga Thrust Washer between the Fold Link and the Wing Frame Hinge Plates. Insert 1-1/4 x 8-1/4 Pin into the side of the Wing Hinge Plate with the Keeper Plate so the Roll Pin fits into the slot. See Figure 2-52. Place two Flat Washers on the end of the Pin. Secure with 5/16 x 2 Roll Pin.
4. Swing the Center Frame and Wing Hinge Links together along with the Hydraulic Cylinder Rod End Clevis. Insert 1-1/4 x 8-1/4 Pin through them. See Figure 2-53. Add 1-1/4 Flat Washers on each end of the Pin. Secure with 5/16 x 2 Roll Pin.

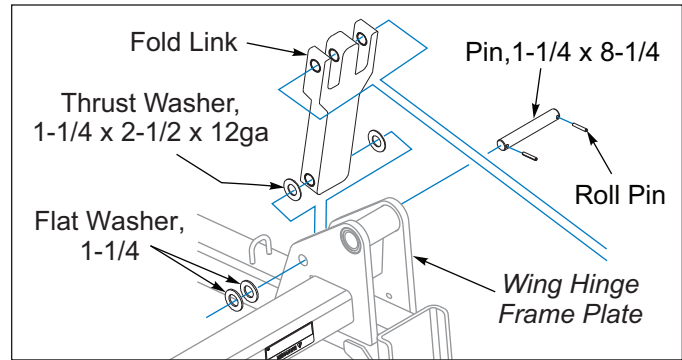

Figure 2-52: Wing Frame Hinge Assembly

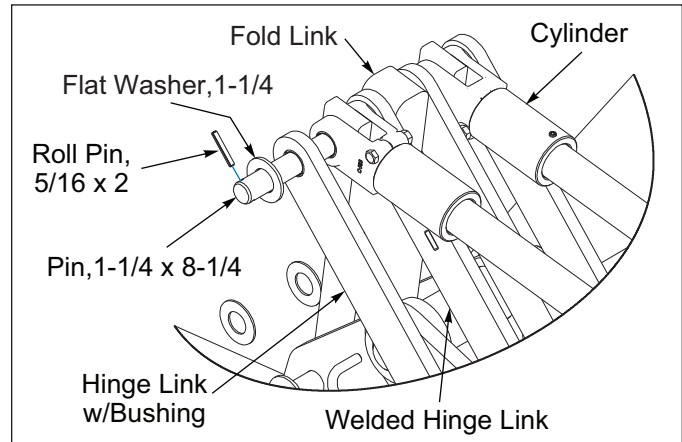

Figure 2-53: Center Frame and Wing Link Assembly

Fold - Unfold Wings

After Assembly of the Wing to Frame Linkage fold and unfold the wings checking for leaks and binding. (Be sure air has been purged). See Page 2-36.

CAUTION

Escaping hydraulic fluid can cause serious personal injury. Relieve system pressure before repairing, adjusting, or disconnecting. Wear proper hand and eye protection when searching for leaks. Use cardboard instead of hands (See Figure 2-54.) Keep all components (cylinders, hoses, fittings, etc.) in good repair.

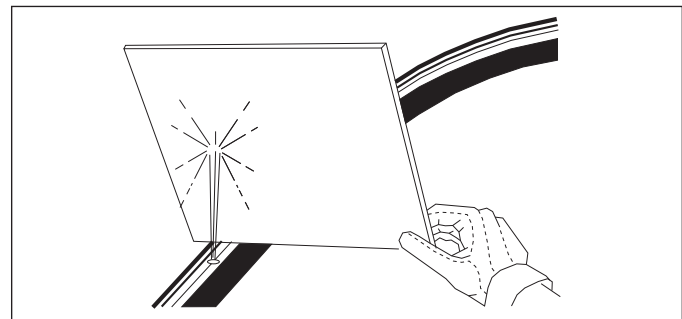

Figure 2-54: Hydraulic Leak Detection

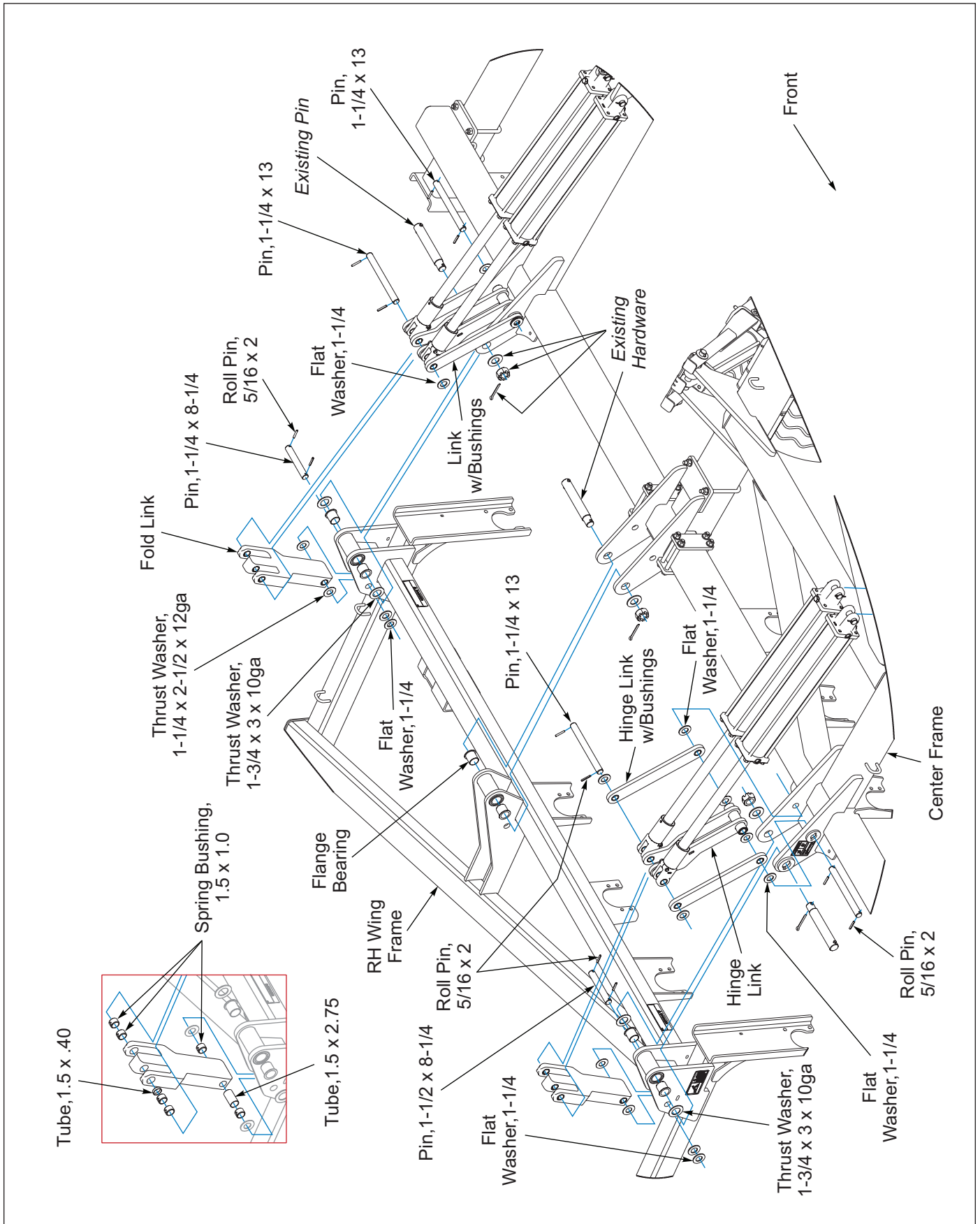

Figure 2-55: Wing Hinge to Frame Installation

Left and Right Hand Wing Roller Installation

NOTE

Roller Axle Assembly clamped end must be on the outer extremity of the Wing.

1. Apply anti-seize to each Roller Stub Shafts.

Each Roller Stub Shaft will utilize a Dirt Shield, a 14ga Shim Washer (thinner), and two 11ga Shim Washers (thicker). The gap between the Roller Stub Shaft shoulder and Bearing Inner Ring must be minimized with the use of Shim Washers and a Dirt Shield. Shim Washers can be all three on the inside between the Stub Shaft shoulder and the Dirt Shield or all three on the outside between the Bearing and the Flat Top Washer, or a combination on either side, but all three must be used to minimize the gap.

2. Insert 5/8-11 x 1-3/4 Bolts into Frame Bearing Hanger. Place a Dirt Shield on each end of the Roller Stub Shaft so that the cupped portion will be towards the Bearing. Slide the Bearing onto the Roller Stub Shaft. Lift up while supporting the Roller Assembly so that the Bearing can be assembled with Locknuts onto the outside of the Frame Bearing Hanger. Bearings should be tight against the Bearing Hanger. Push the Dirt Shield against the Bearing inner ring and check the gap on each end between the Dirt Shield and Roller Stub Shaft Shoulder. Remove Bearing and add Shim Washer(s) as necessary. **See Figures 2-56 and 2-57.** The bearing inner ring has an internal rubber mount to allow for up to 1/16" of excess gap.
3. Place the remaining Shim Washer(s) on the Roller Stub Shaft outside of the bearing against the inner ring. Install Flat Top Washer and 3/8" Thick Washer onto shaft. Secure with 1-8 x 2-1/4 Bolt and Lock Washer.

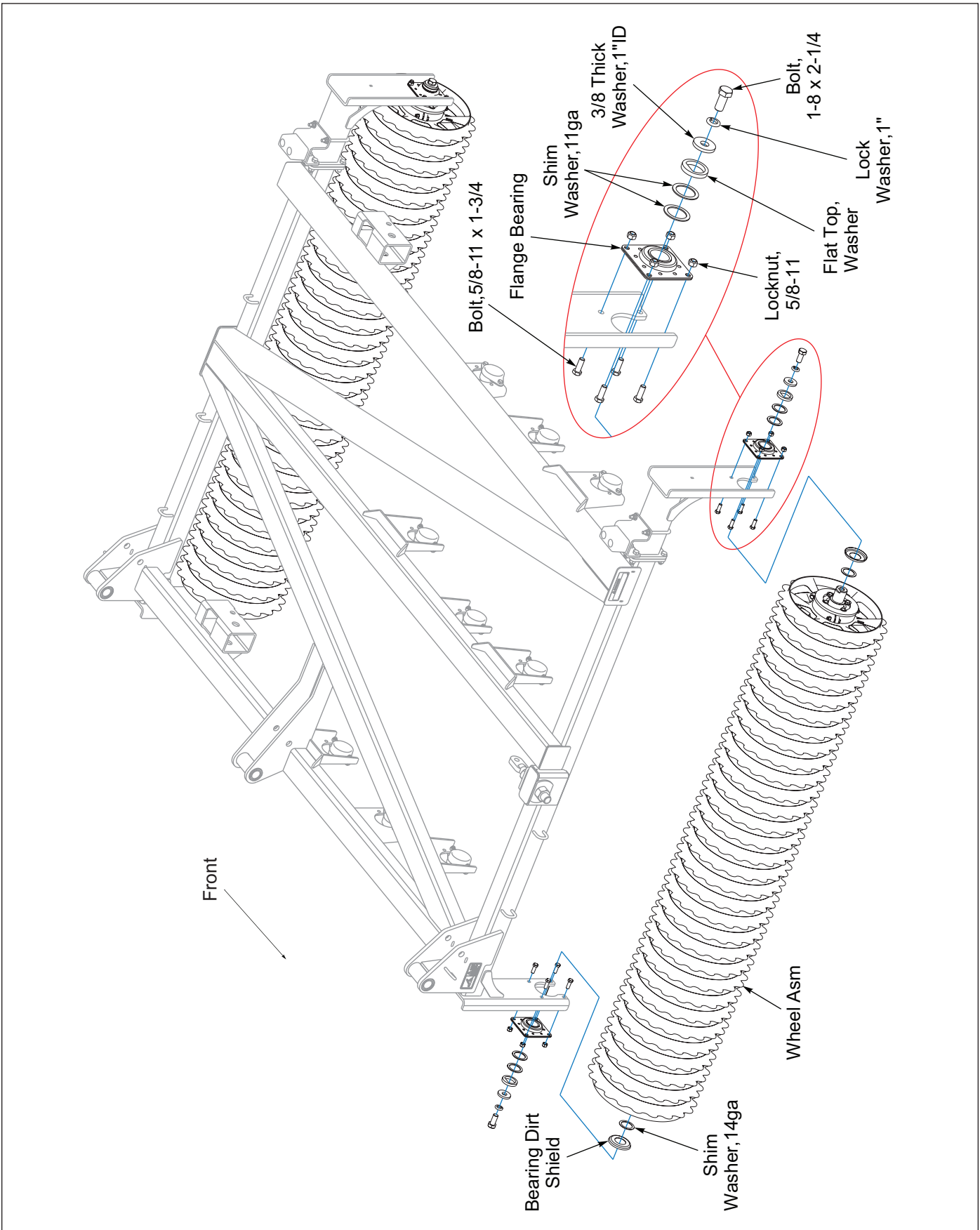

Figure 2-56: Left Hand Wing Roller Installation

Wing Tooth Control Cylinder Installation

Install the base end 4 x 8 Rephasing Hydraulic Cylinders to the Cylinder Anchors on the front of the LH and RH Wing Frames with the vendor supplied hardware. Adjust the Anchor Nuts to achieve a distance of approximately 6-1/2" from the Center Frame Tube to the center of the Cylinder Pin. **See Figure 2-58.**

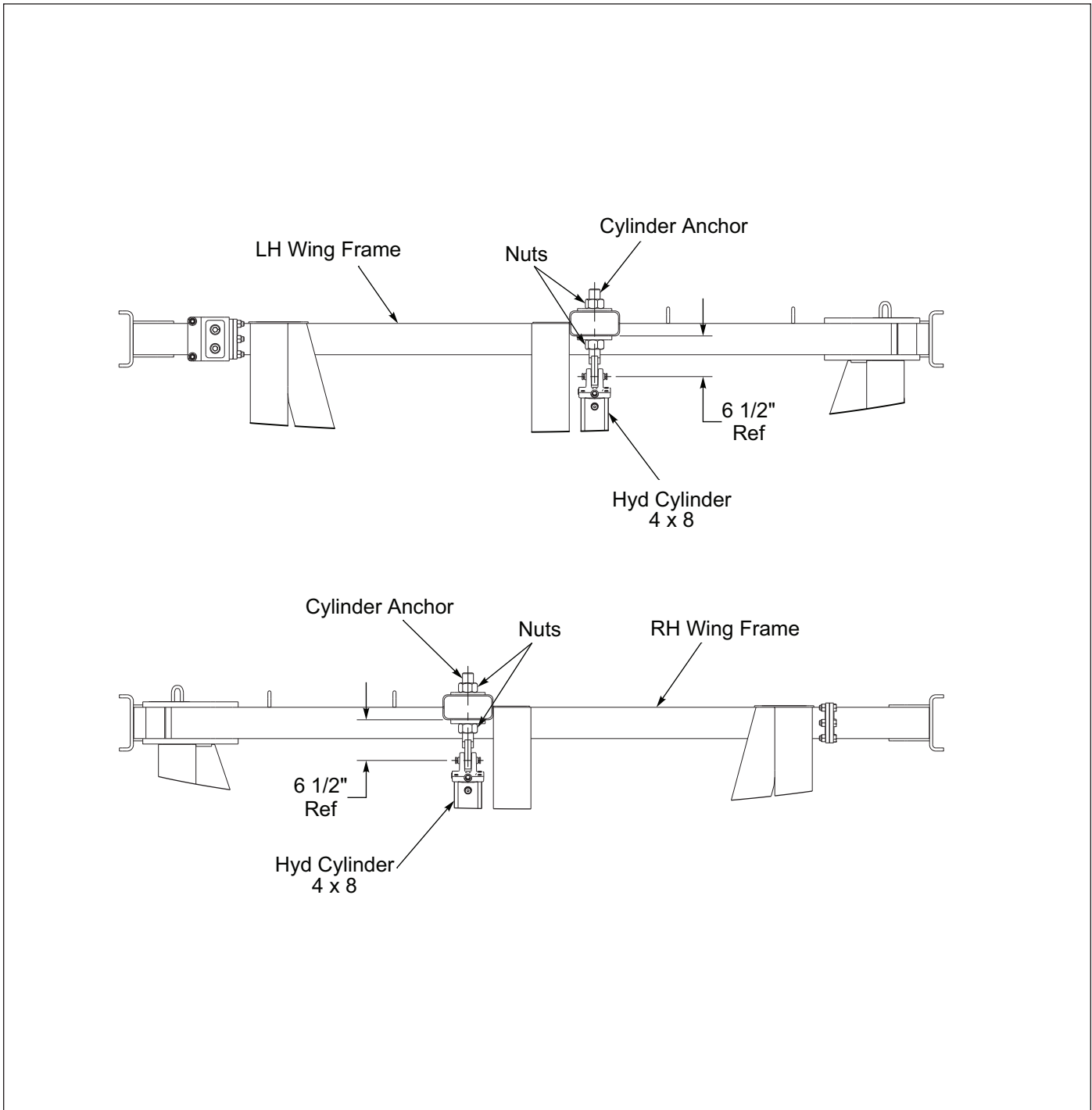

Figure 2-58: Wing Tooth Control Cylinder Installation

Wing Tooth Tube Installation

Verify Tooth Tube Bearings are positioned in the proper hole.

Bottom Hole: Roller with 24" Diameter Wheels. See **Figure 2-59**.

1. After marking the tubes for the shank locations, slide the 116" Tooth Tubes into the Tooth Tube Bearings accordingly. See **Figures 2-61 and 2-62**.
2. Position Tooth Tubes in the proper lateral position to the wing frame before continuing. See **Figures 2-63 and 2-64**.
3. Place Stops on Tooth Control Tube against Tooth Tube Bearing to prevent Tooth Control Tube from sliding right or left. Secure with 1/2-13 x 4-1/2 Bolts and Locknuts. See **Figures 2-60, 2-61 and 2-62**.

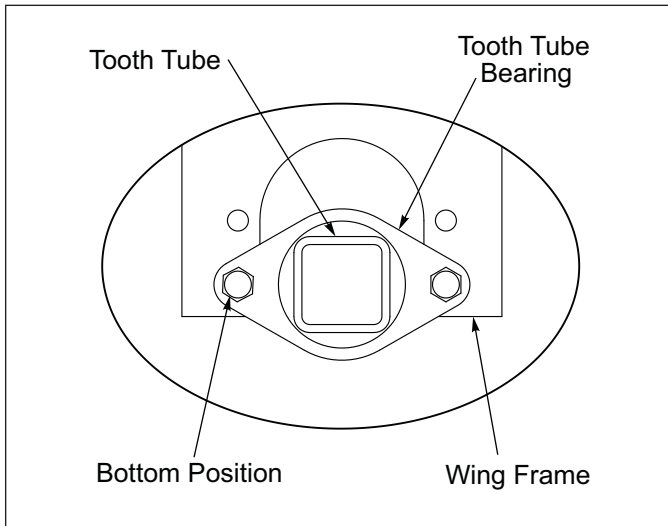

Figure 2-59: Wing Tooth Tube Bearing Position for Roller with 24" Wheels

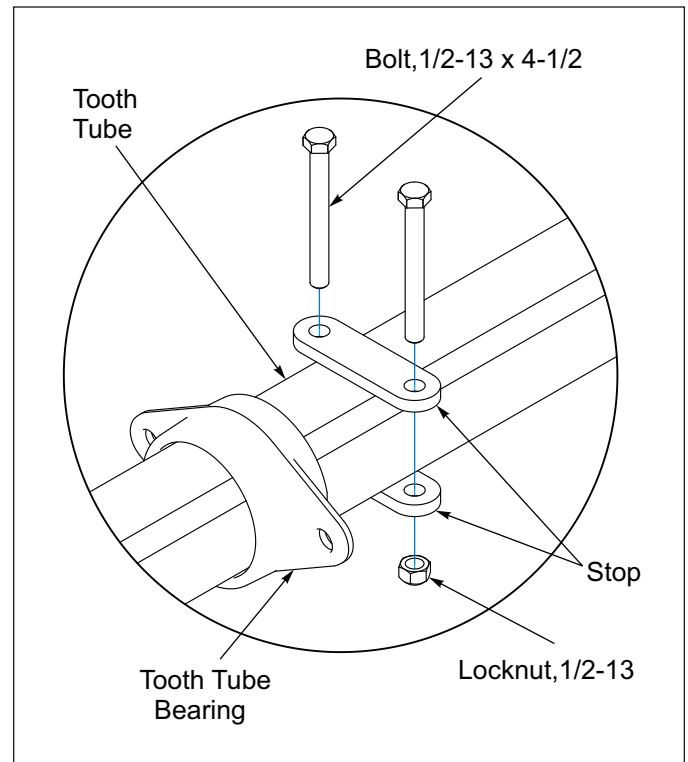

Figure 2-60: Wing Tooth Control Tube Stop

Wing Shank Mounting Dimensions

Mark the tubes for Shank locations prior to installing the tubes. Do Not mount the Shanks to the tubes at this time.

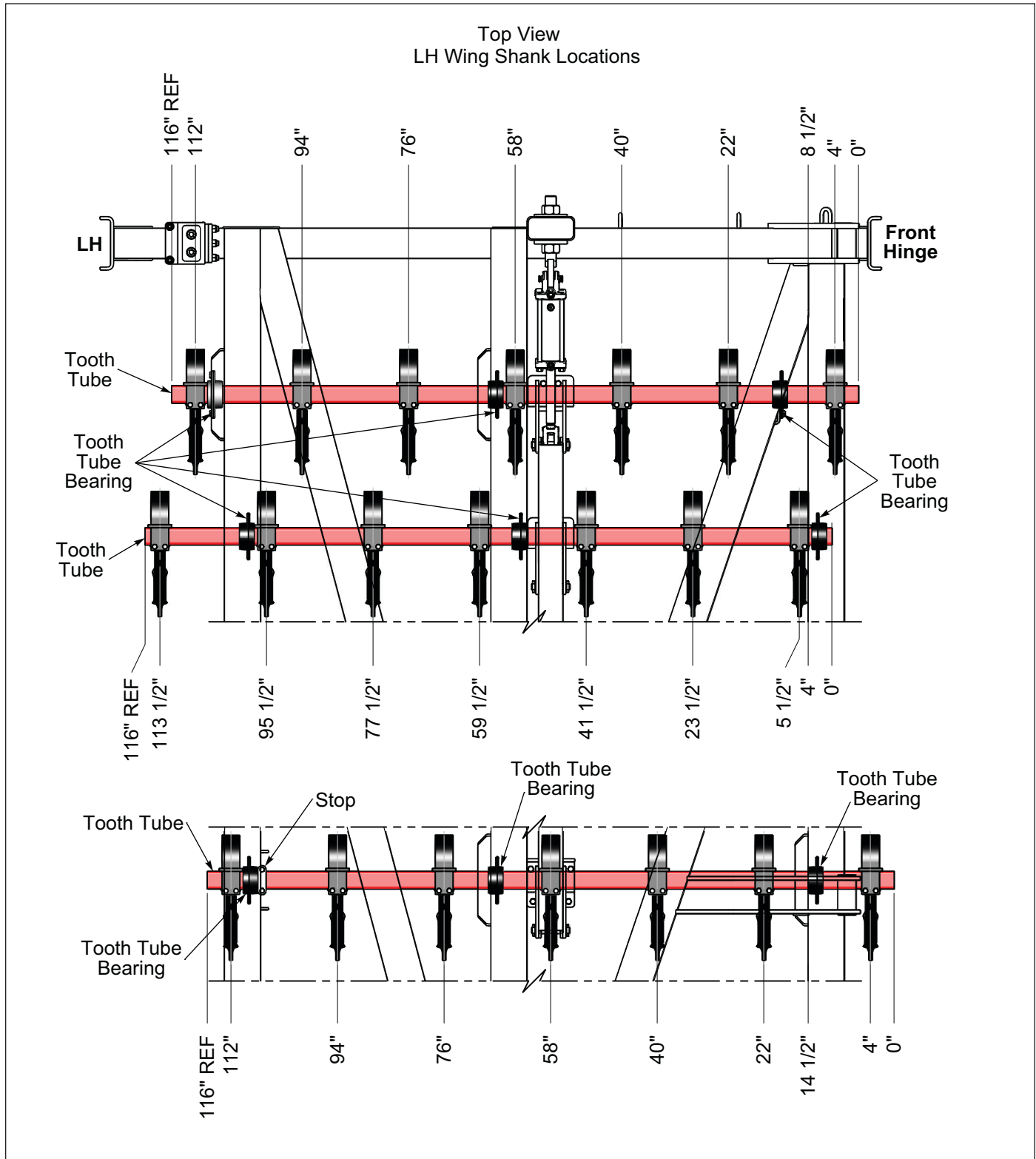

Figure 2-61: Left Hand Wing Shank Mounting Dimensions

Wing Tooth Control Mounting Dimensions

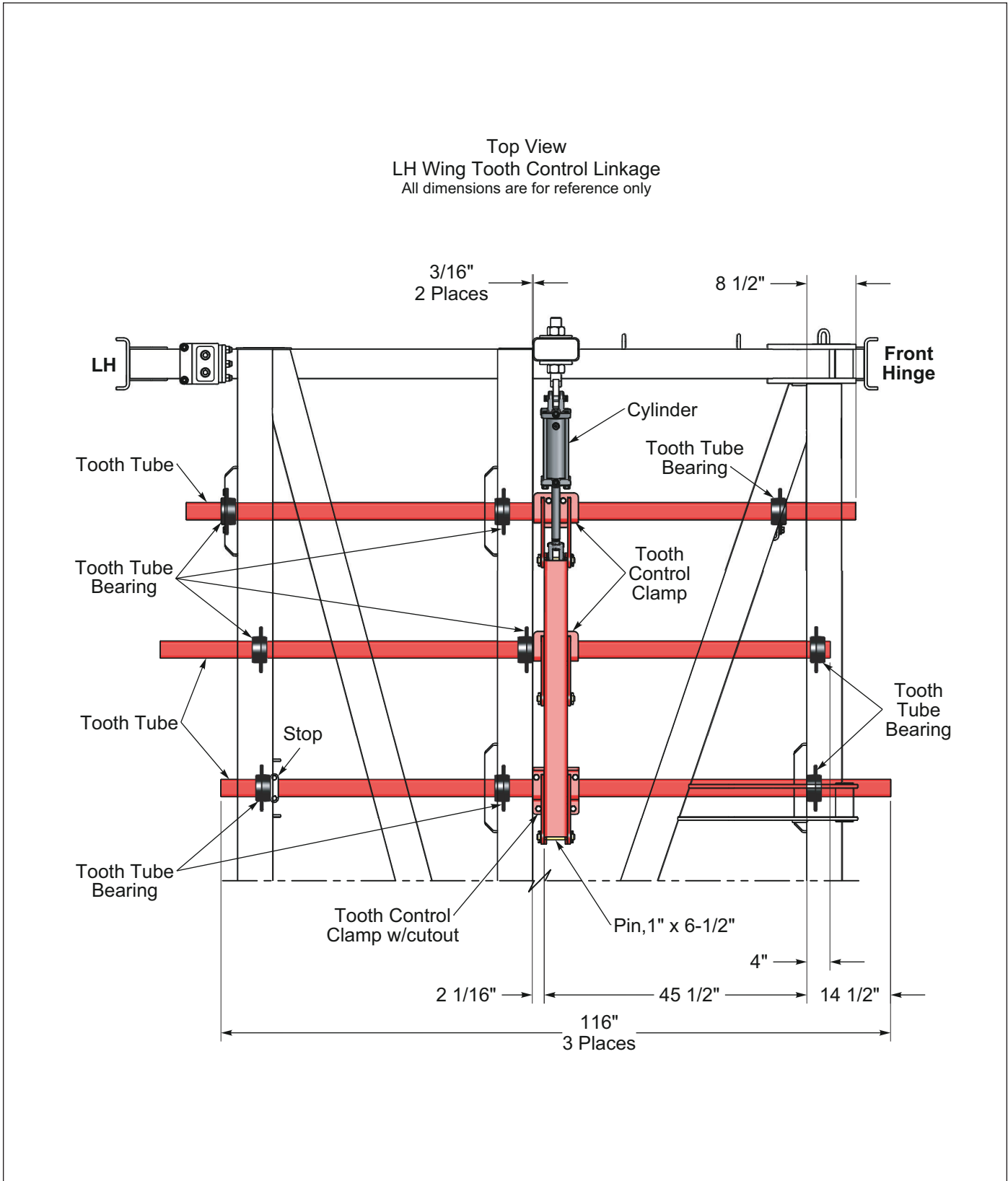

Figure 2-63: Left Hand Wing Tooth Control Linkage

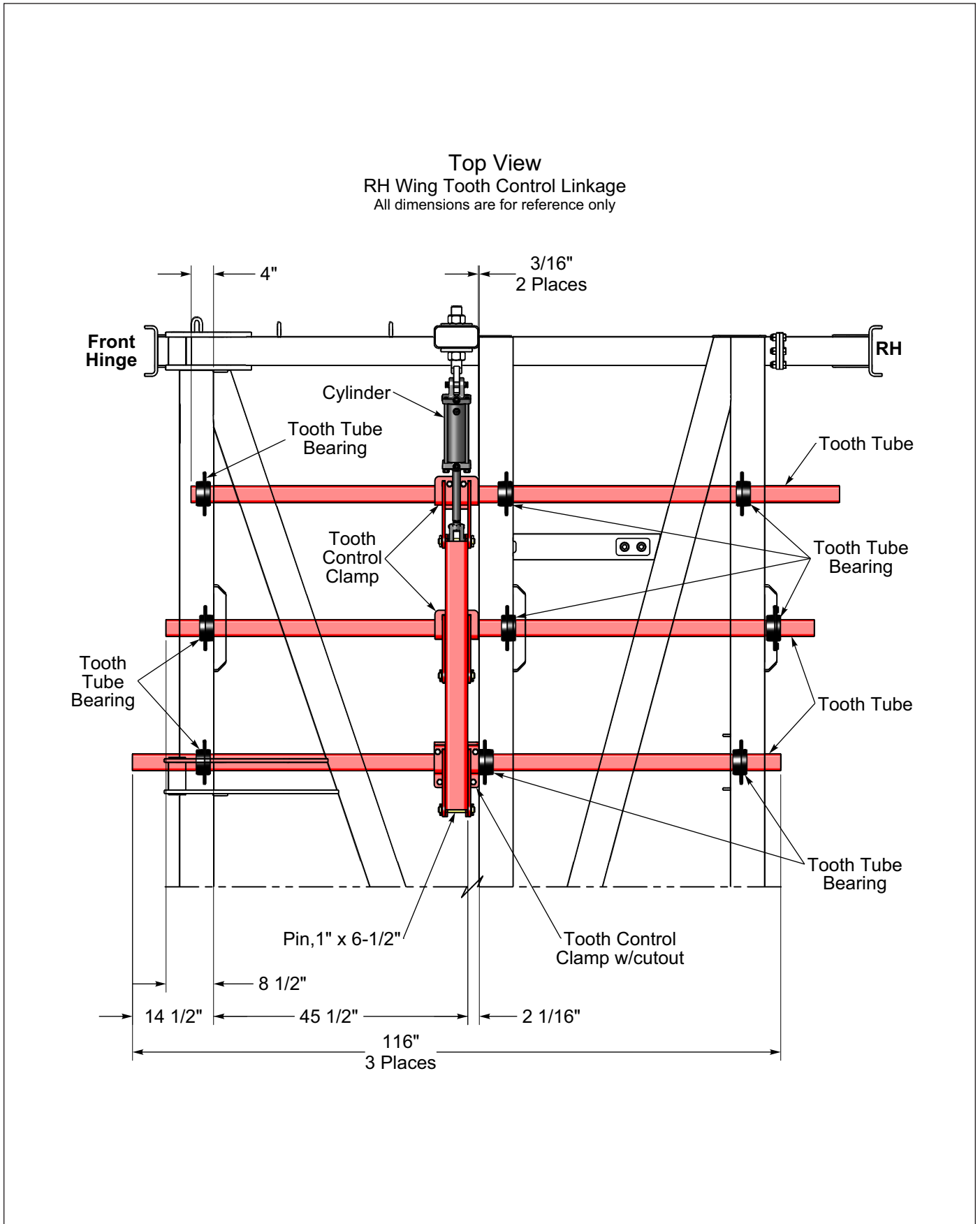

Figure 2-64: Right Hand Wing Tooth Control Linkage

Wing Tooth Control Installation

NOTE

2-Hole Strap Stops hold the position of Tooth Tubes.

Left Wing

1. Attach a Tooth Control Bracket on the top of the Front Tooth Tube by sliding a Clamp Plate into the Tooth Control Bracket Slot and under the Tooth Tube. Fasten with 5/8-11 x 5 Bolts and Locknuts, **Do Not** tighten at this time. **See Figure 2-65.**
2. Lay the Cylinder Rod Clevis between the Tooth Control Bracket Lugs. Position the Tooth Control Tube over the top of the Cylinder Rod Clevis and between the Tooth Control Bracket Lugs and insert a 1 x 6-1/2 Pin. Place a 1" Flat Washer on each side of the Pin against the Tooth Control Bracket. Secure with 5/16 x 2 Roll Pins.
3. Position a Tooth Control Clamp w/cutout on top of the Rear Tooth Tube while straddling the Tooth Control Tube. Insert 1 x 6-1/2 Pins. Place a 1" Flat Washer on each side of the Pin against the Tooth Control Clamp and secure with 5/16 x 2 Roll Pins. Tooth Control Clamps should be aligned with each other.
4. Attach Tooth Control Clamp on the Tooth Tube with two 5/8-11 x 5 Bolts and two 5/8-11 x 2 Bolts and Locknuts and 4 Hole Plate.
5. Position a Tooth Control Bracket on top of the Left Middle Tooth Tube while straddling the Tooth Control Tube. Insert 1 x 6-1/2 Pins. Place a 1" Flat Washer on each side of the Pin against the Tooth Control Bracket and secure with 5/16 x 2 Roll Pins.
6. Attach Tooth Control Bracket on Tooth Tube by sliding a Clamp Plate into the Tooth Control Bracket Slot and under the Tooth Tube. Fasten with 5/8-11 x 5 Bolts and Locknuts.

Tighten hardware after positions of clamps and tube have been verified. **See Figure 2-63.**

Right Side

1. Attach a Tooth Control Bracket on the top of the right Front Tooth Tube by sliding a Clamp Plate into the Tooth Control Bracket Slot and under the Tooth Tube. Fasten with 5/8-11 x 5 Bolts and Locknuts, **Do Not** tighten at this time. **See Figure 2-66.**
2. Lay the Cylinder Rod Clevis between the Tooth Control Bracket Lugs. Position the Tooth Control Tube over the top of the Cylinder Rod Clevis and between the Tooth Control Bracket Lugs and insert a 1 x 6-1/2 Pin. Place a 1" Flat Washer on each side of the Pin against the Tooth Control Bracket. Fasten with 5/16 x 2 Roll Pins.
3. Position a Tooth Control Clamp w/cutout on top of the right Rear Tooth Tube while straddling the Tooth Control Tube. Insert 1 x 6-1/2 Pins. Place a 1" Flat Washer on each side of the Pin against the Tooth Control Clamp and fasten with 5/16 x 2 Roll Pins. Tooth Control Clamps should be aligned with each other.
4. Attach Tooth Control Clamp on the Tooth Tube with two 5/8-11 x 5 Bolts and two 5/8-11 x 2 Bolts and Locknuts and 4 Hole Plate. Ensure that both linkages don't bind and the Tooth Control Clamps and the Tooth Tubes are positioned correctly. Tighten the Bolts and Nuts at this time.
5. Position a Tooth Control Bracket on top of the right Middle Tooth Tube while straddling the Tooth Control Tube. Insert 1 x 6-1/2 Pins. Place a 1" Flat Washer on each side of the Pin against the Tooth Control Bracket and secure with 5/16 x 2 Roll Pins.
6. Attach Tooth Control Bracket on Tooth Tube by sliding a Clamp Plate into the Tooth Control Bracket Slot and under the Tooth Tube. Fasten with 5/8-11 x 5 Bolts and Locknuts.

Tighten hardware after positions of clamps and tube have been verified. **See Figure 2-64.**

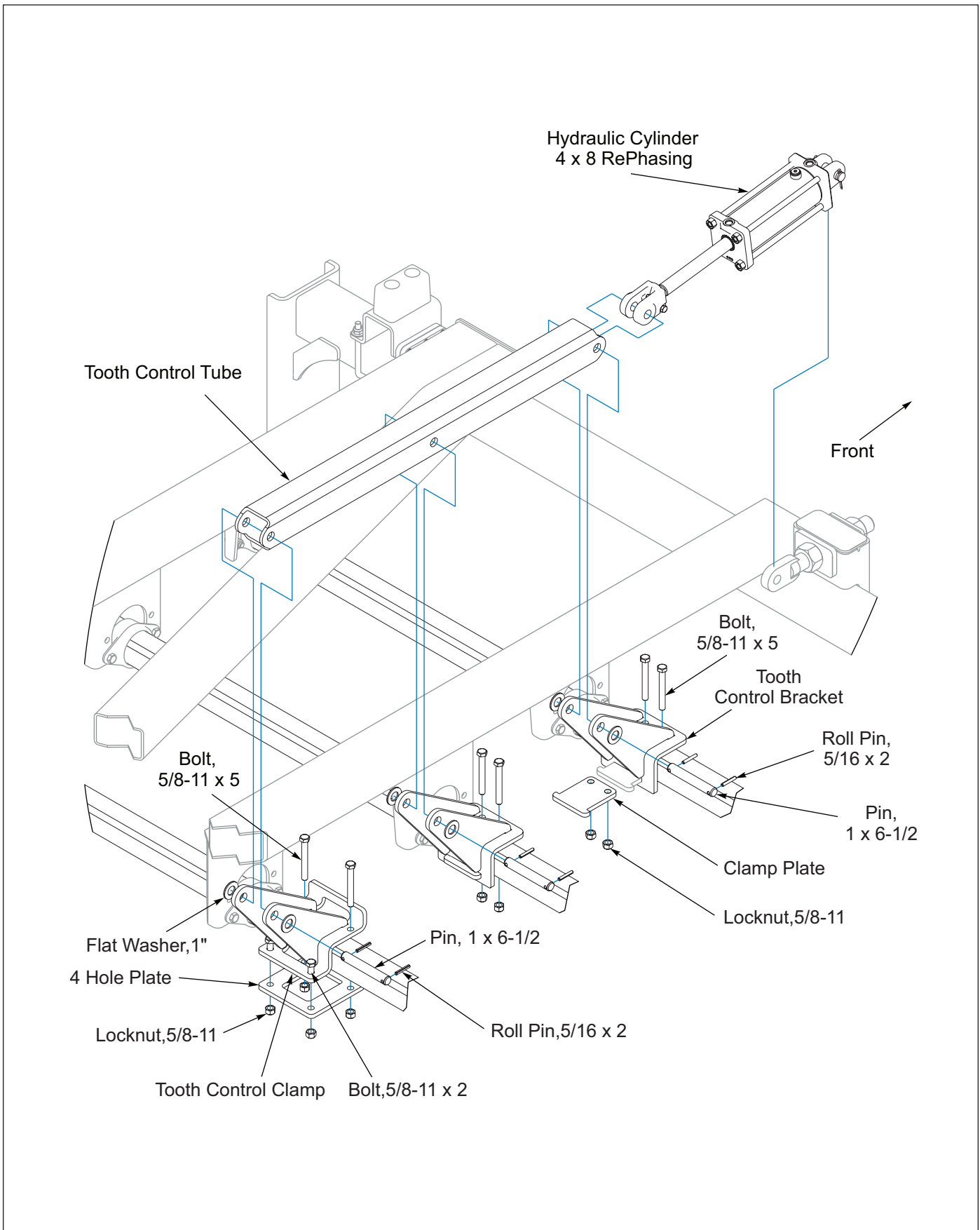

Figure 2-65: Left Hand Wing Tooth Control

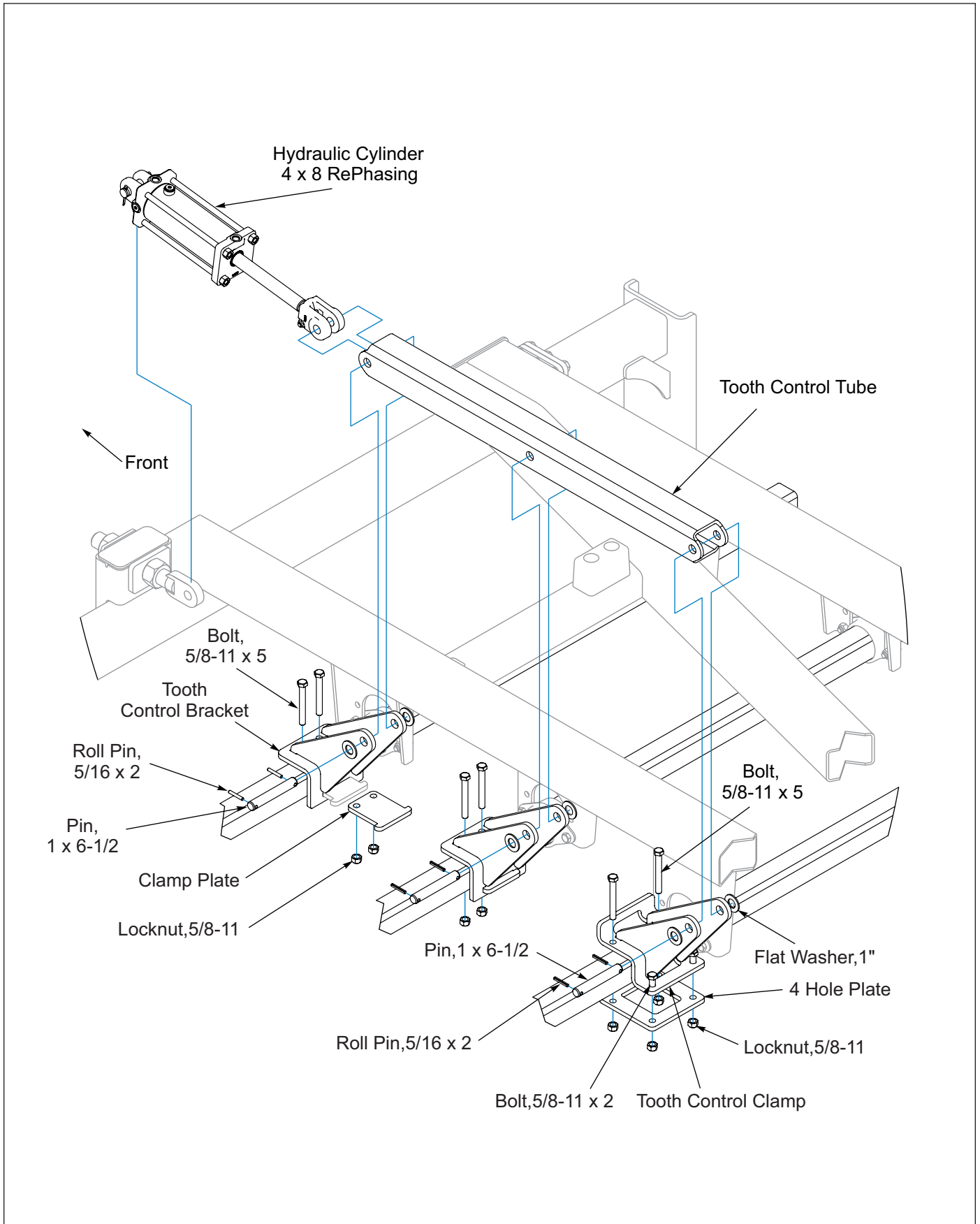

Figure 2-66: Right Hand Wing Tooth Control

Plumb Wing Tooth Control Cylinders

1. Install fitting into 4 x 8 Wing Rephasing Hydraulic Cylinders. See Figures 2-19 and 2-20.
2. Route Wing Tooth Control hoses from center frame along front of wing frame to wing cylinders. Wrap both hoses together with 26" hose wrap at hinge areas.
3. Secure all hoses with Cable Ties and Tywraps.



WARNING

Escaping hydraulic fluid can cause serious personnel injury. Relieve system pressure before repairing, adjusting, or disconnecting. Wear proper hand and eye protection when searching for leaks. Use cardboard instead of hands. See Figure 2-67. Keep all components (cylinders, hoses, fittings, etc.) in good repair.

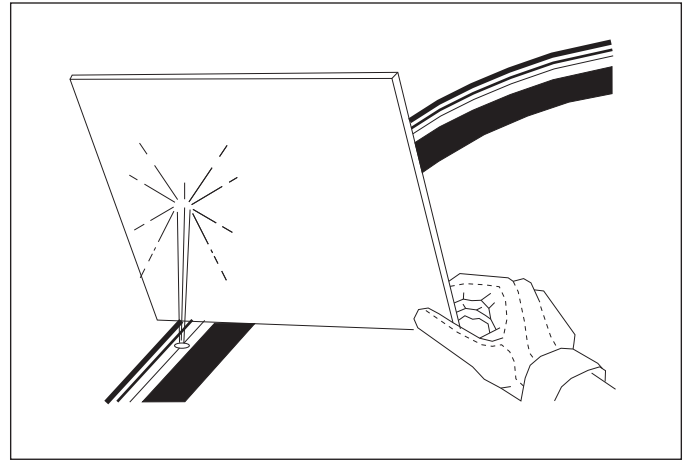

Figure 2-67: Hydraulic Leak Detection

Purging the Tooth Control Cylinders

Pulvi-Mulcher Tooth Control Cylinders are series cylinders that rephase on retract.

1. The hydraulic system is not filled with oil and should be purged of air before transporting and field operations. Check to make sure the tractor hydraulic reservoir is full of the manufacturer's recommended oil.
2. Raise the machine. Slowly raise the Shanks and continue to hold the hydraulic lever until all Tooth Control Cylinders are fully retracted. Lower and raise the shanks to verify that all cylinders are working simultaneously throughout the stroke. If the cylinders are not working evenly or together, fully retract the tooth control cylinders and continue to hold the lever to purge any remaining air.
3. Do not loosen any hoses or fittings.
4. Recheck tractor reservoir to make sure it is within operating limits.

The Tooth Control Circuit with shanks raised requires approximately 2.3 gallons of hydraulic oil, and with shanks lowered requires 2.6 gallons of hydraulic oil.

Wing Shank Installation

1. Engage Transport Locks

NOTE

It is easier to bolt the points to the shank before mounting them on the machine.

NOTE

*If machine requires Optional Front Scrapers: Lower the machine on a level surface and install scrapers before installing shanks. **See Scraper Section on page 2-82.** Front Scraper installation is similar to rear. It is easier to install shanks while machine is raised.*

2. Assemble Points to Shanks as shown in **Figure 2-68**.
3. Mount the Shanks to the Wing Tooth Control Tubes using two 1/2-13 x 5 Bolts and Locknut. **See Figures 2-61 and 2-62** for Left and Right hand Shank Mounting Dimensions.

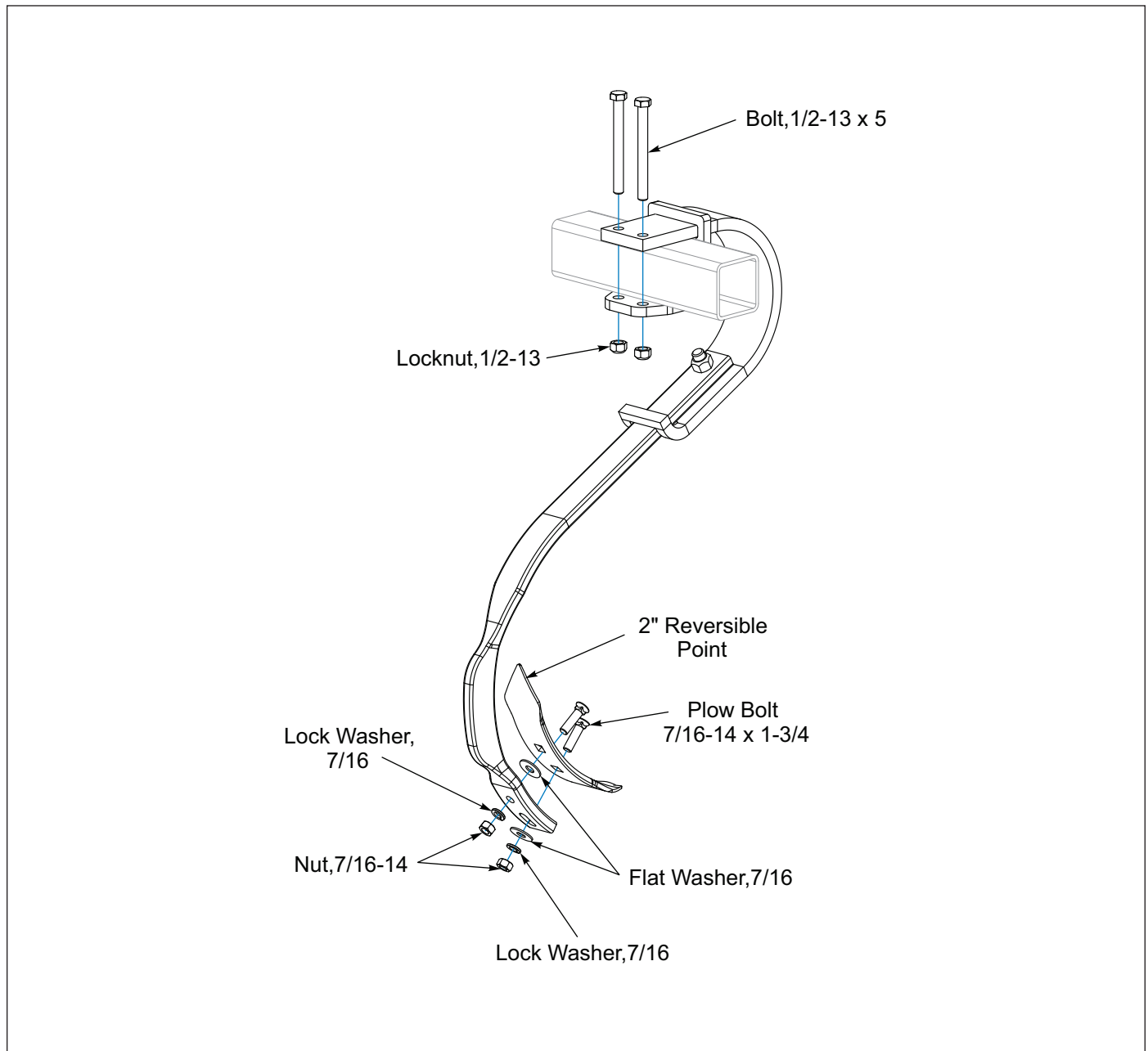

Figure 2-68: Wing Shank Installation

Wing 2-Row Harrow Installation

1. Remove 1 x 7-5/16 Pins from each Wing Frame Adjuster Mount. Insert a Harrow Adjustment Tube into each Wing Frame Adjuster Mount and re-insert 1 x 7-5/16 Pin in the bottom hole. Secure with 3/16 Hair Pin Cotter. See Figures 2-69 and 2-70.

2. The LH and RH Wing 2-Bar Harrow comes factory assembled. Lift Harrow Assembly and slide the Harrow 3 x 3 Tube into the cut-out portion of the Harrow Adjustment Tube and insert a 1/2-13 U-Bolt on each side. Check Harrow position in relation to the Frame and secure with Flat Washer and Locknut. See Figures 2-71 and 2-72.

3. Install a 1/2-13 x 5 Bolt and Locknut into the top hole of each Harrow Adjustment Tube.

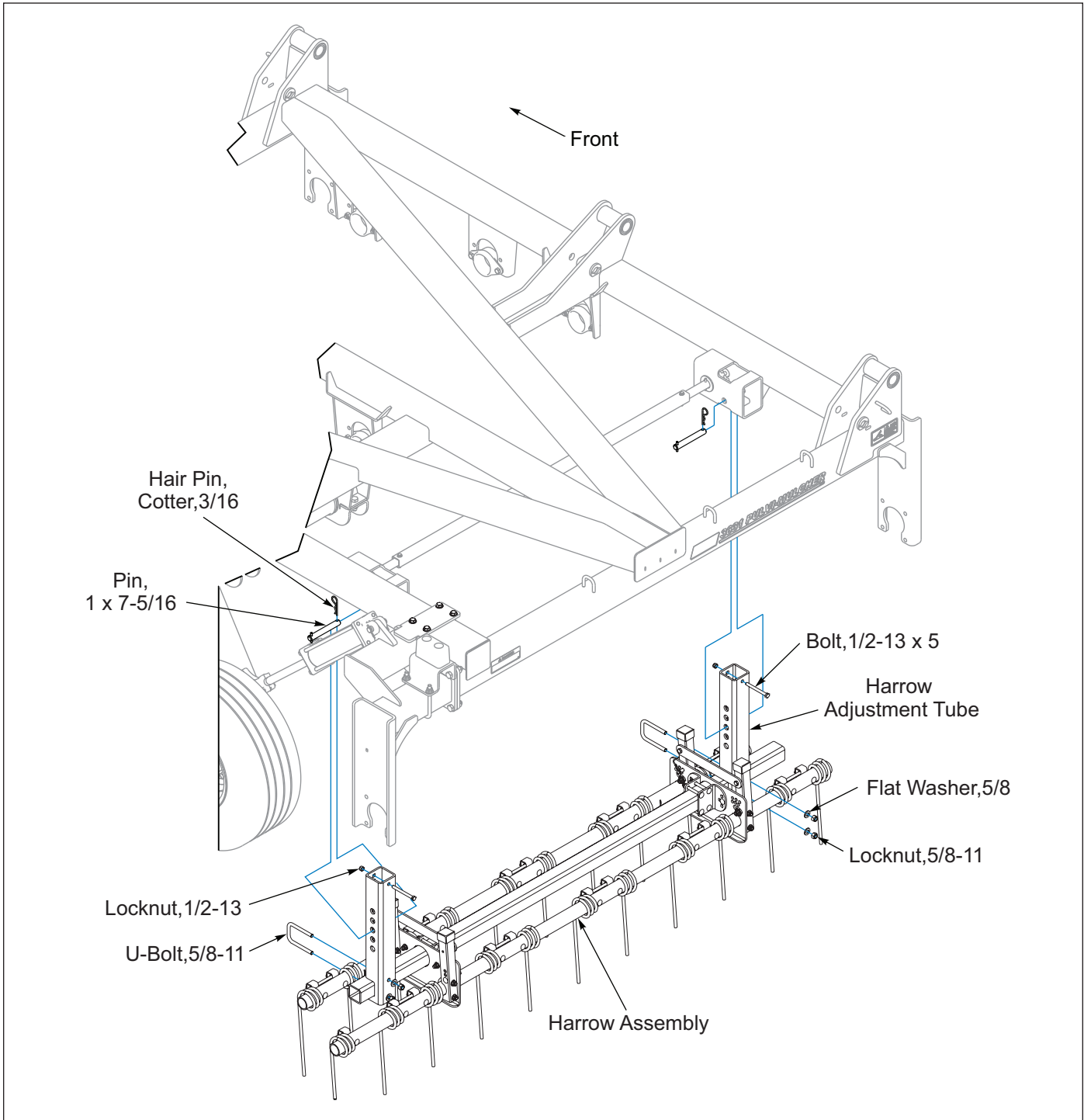

Figure 2-69: Left Hand Wing Harrow

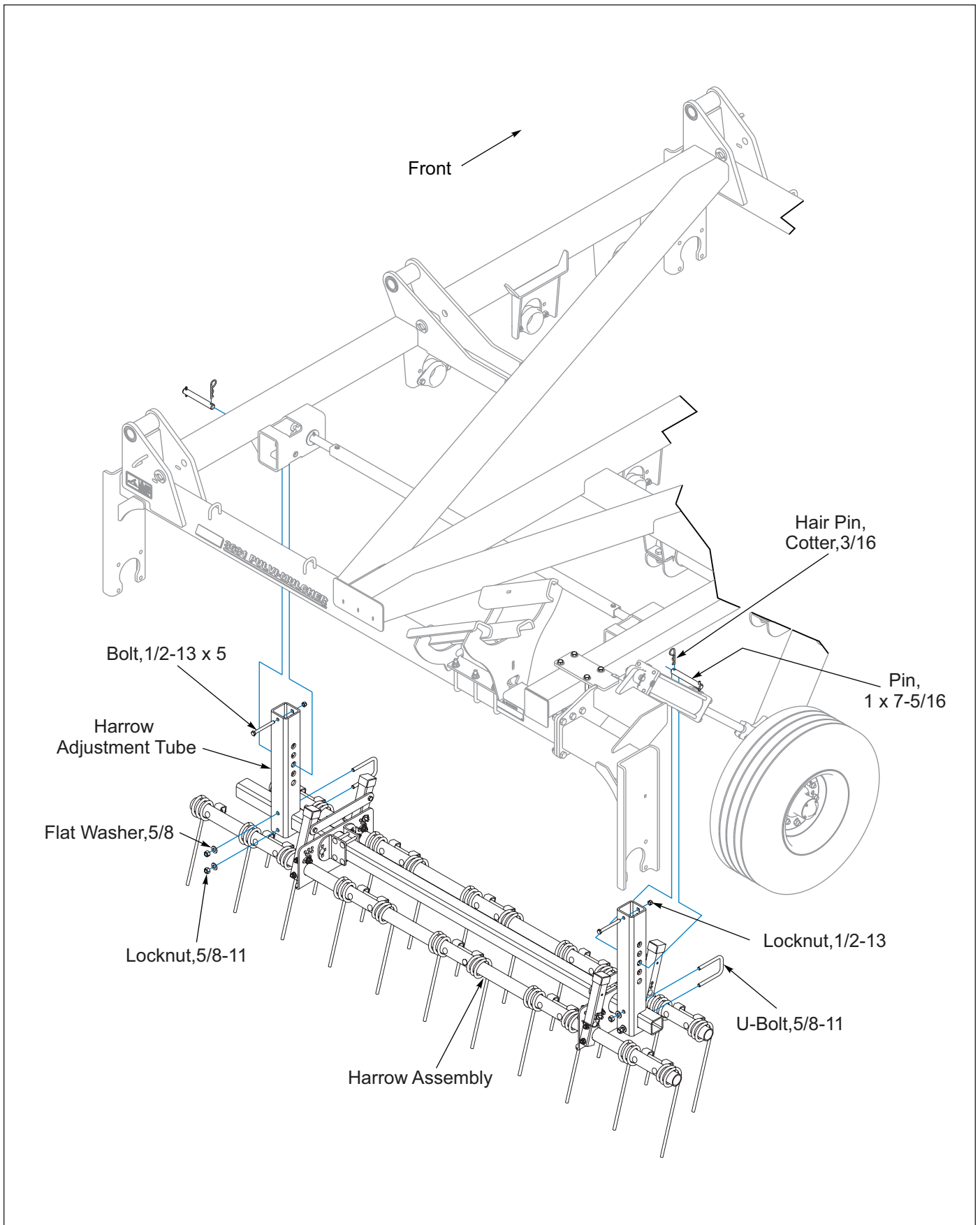

Figure 2-70: Right Hand Wing Harrow

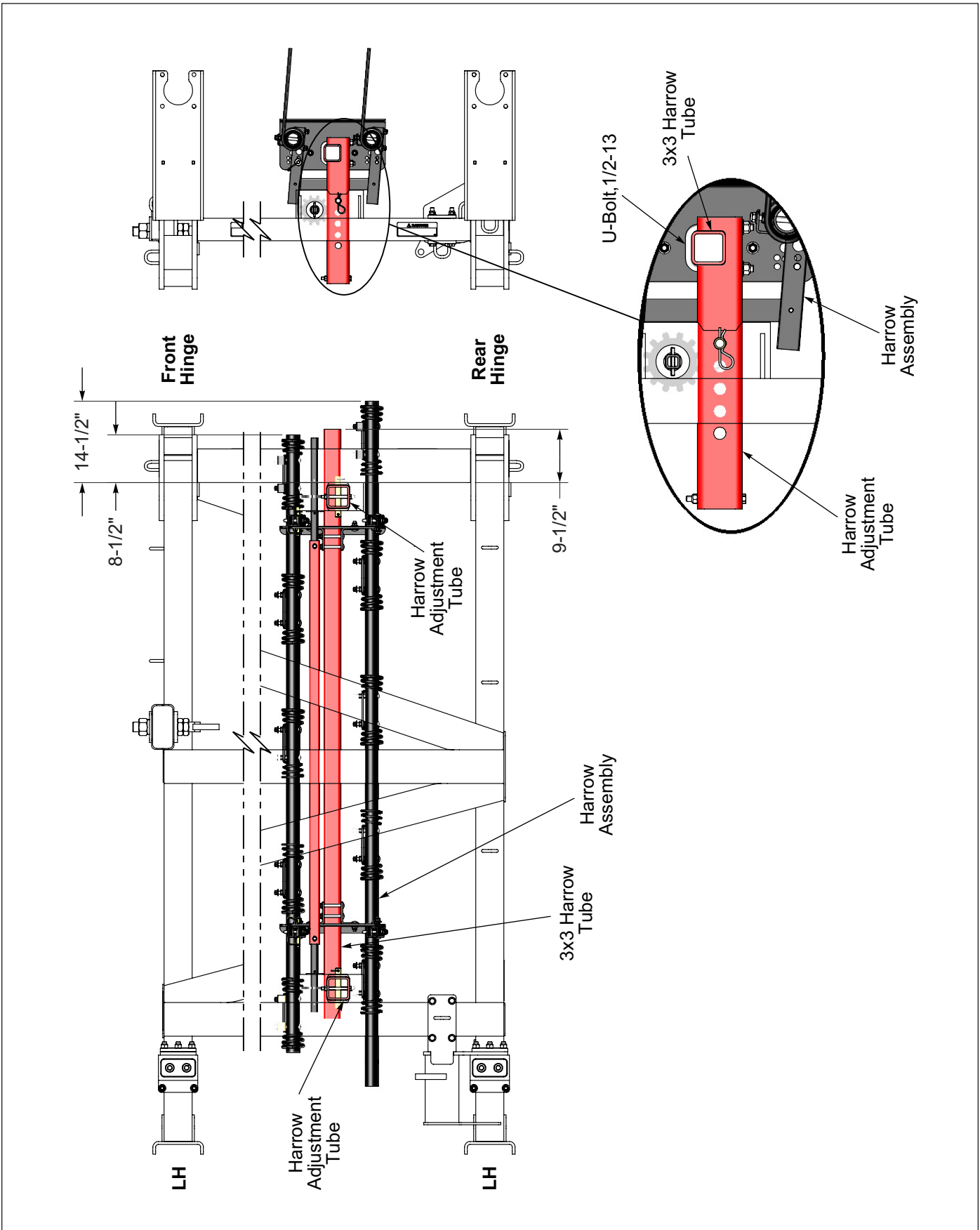

Figure 2-71: Left Hand Wing Harrow Dimension

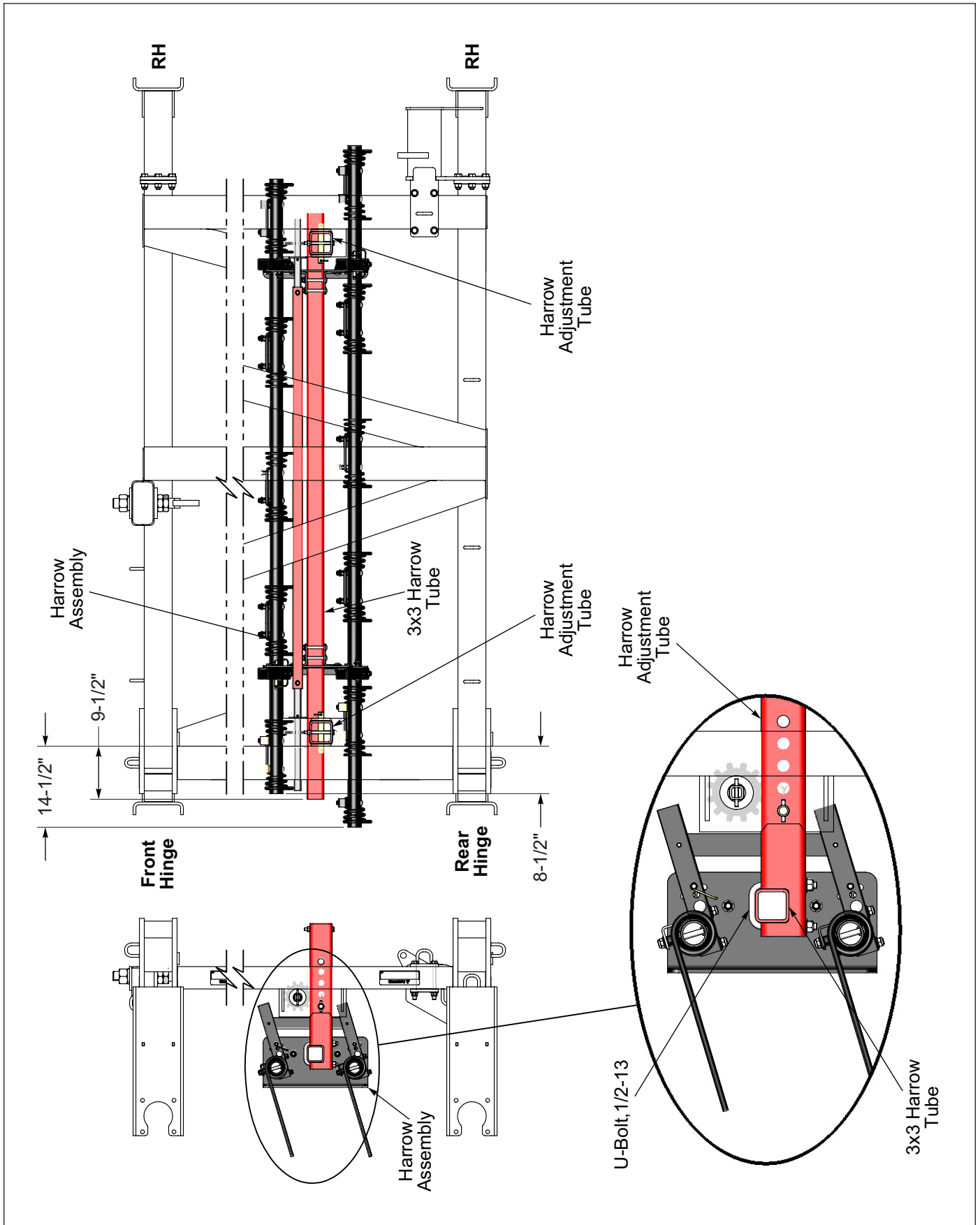

Figure 2-72: Right Hand Wing Harrow Dimension

Roller Clamp Spacer Installation

1. Raise the Machine and install Transport Locks. Wings should be unfolded.
2. Check Roller Wheel Assemblies to ensure that the wheels are tight together. If not, starting at the welded stop end, slide the wheels tight together and adjust the axle clamps so that it's against the wheel.

3. If there is a gap between the Axle Clamp and the Wheel Stop, install the appropriate Clamp Spacer with 3/8-16 x 1-3/4 Bolt and Locknut. **See Figure 2-73.**

See Maintenance Section for a list of other Kits that are available. **See Figures 4-5 and 4-6.**

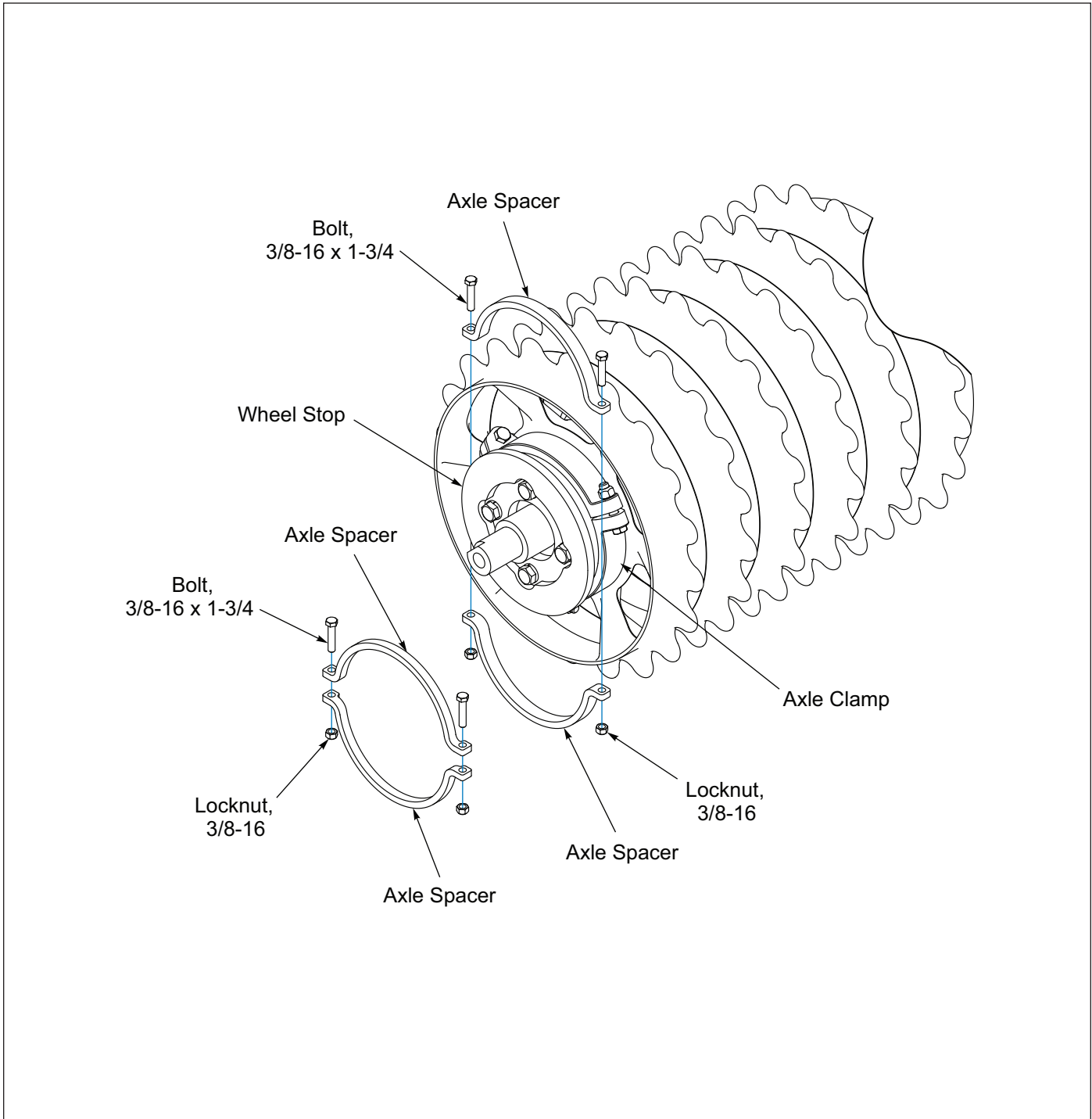

Figure 2-73: Roller Clamp Space Installation

Center Rear Scraper Installation

1. With the Rollers on level ground, place the 5/8-11 U-bolts over the frame tube and through the Center Scraper Brackets, secure with Flanged Locknut. See Figures 2-74 and 2-75.

NOTE

A scraper can be used as a guide to achieve the 1/4" gap.

2. Assemble the Scraper Tube to the Center Scraper Brackets with a 3/8-16 U-Bolts, Scrapers and Flanged Locknuts. Center the Scraper between the Notched Wheels and adjust the Scraper so that there is a 1/4" gap between the Scraper and Notched Wheel. Tighten.
3. Attach the Scrapers to the Scraper Tube with 3/8-16 U-Bolts and Flanged Locknuts, ensure that the scrapers are centered between the Notched Wheels along with a 1/4" gap between the Scraper and Notched Wheel.

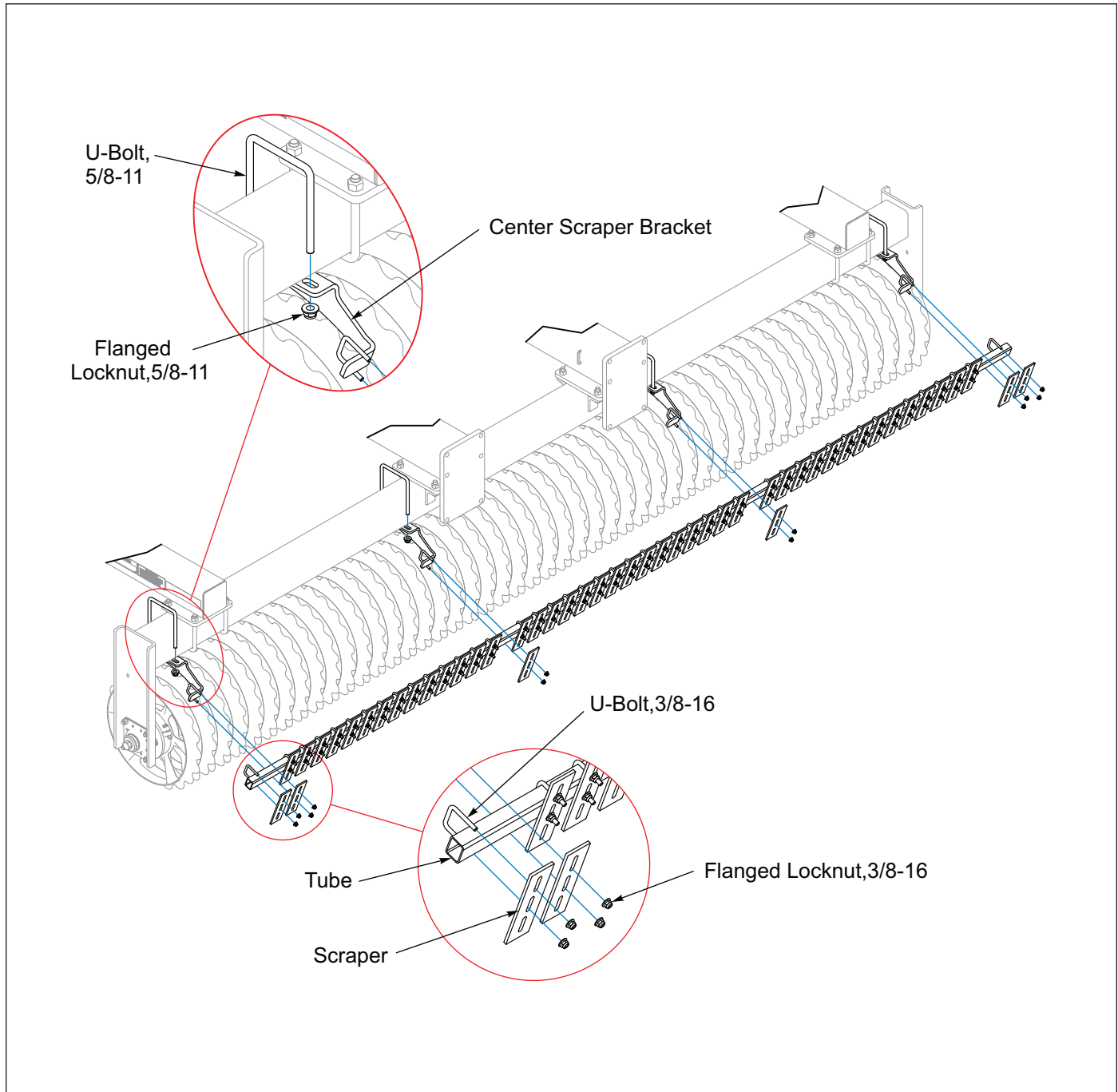

Figure 2-74: Center Rear Scraper Installation

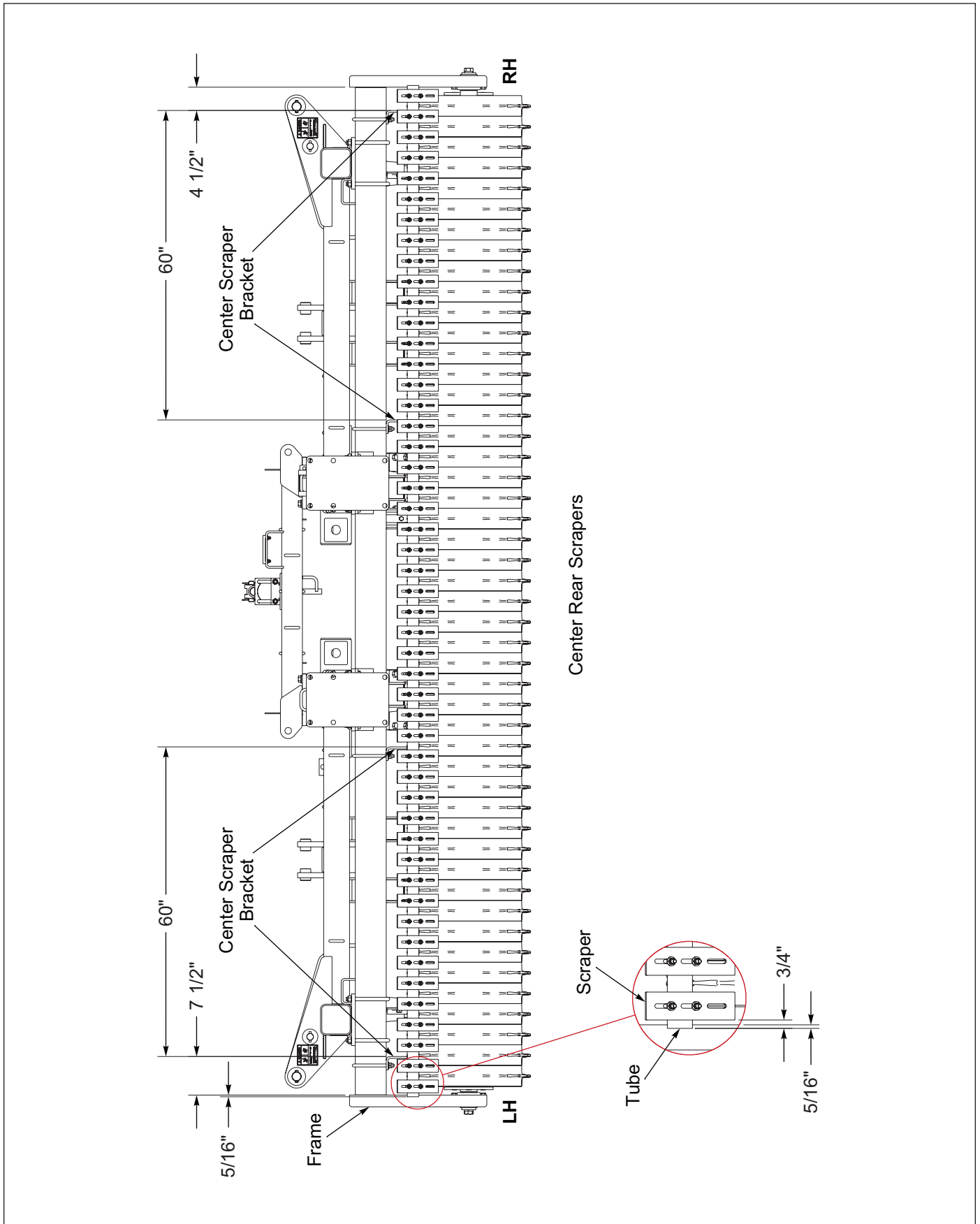

Figure 2-75: Center Rear Scraper Mounting Dimensions

Wing Rear Scraper Installation

1. With the Wing Rollers on level ground, place the 5/8-11 U-bolts over the frame tube and through the Wing Scraper Brackets, secure with Flanged Locknut. See Figures 2-76 and 2-77.

NOTE

A scraper can be used as a guide to achieve the 1/4" gap.

2. Assemble the Scraper Tube to the Wing Scraper Brackets with a 3/8-16 U-Bolts, Scrapers and Flanged Locknuts. Center the Scraper between the Notched Wheels and adjust the Scraper so that there is a 1/4" gap between the Scraper and Notched Wheel. Tighten.
3. Attach the Scrapers to the Scraper Tube with 3/8-16 U-Bolts and Flanged Locknuts, ensure that the scrapers are centered between the Notched Wheels along with a 1/4" gap between the Scraper and Notched Wheel.

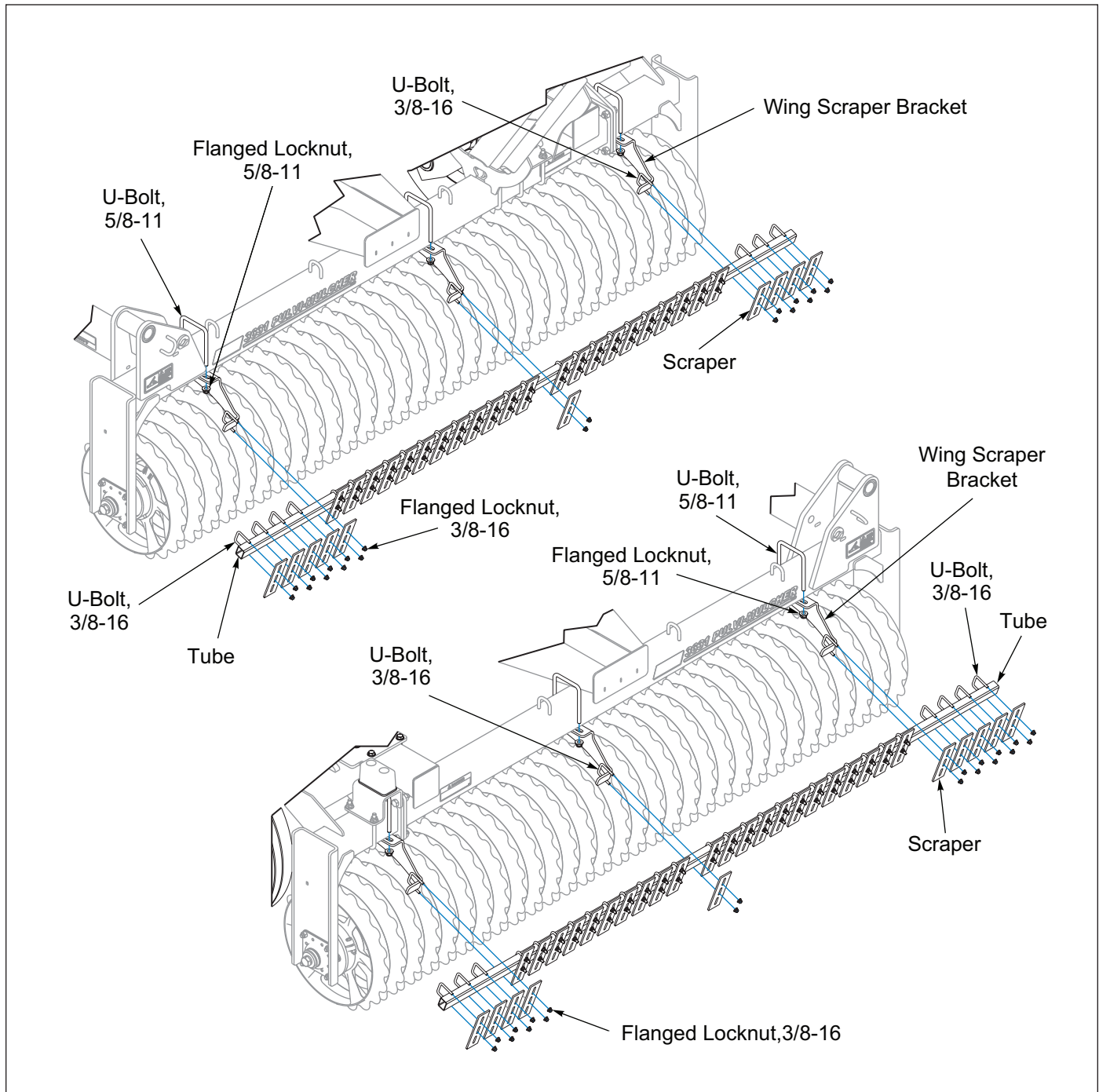

Figure 2-76: Wing Rear Scraper Installation

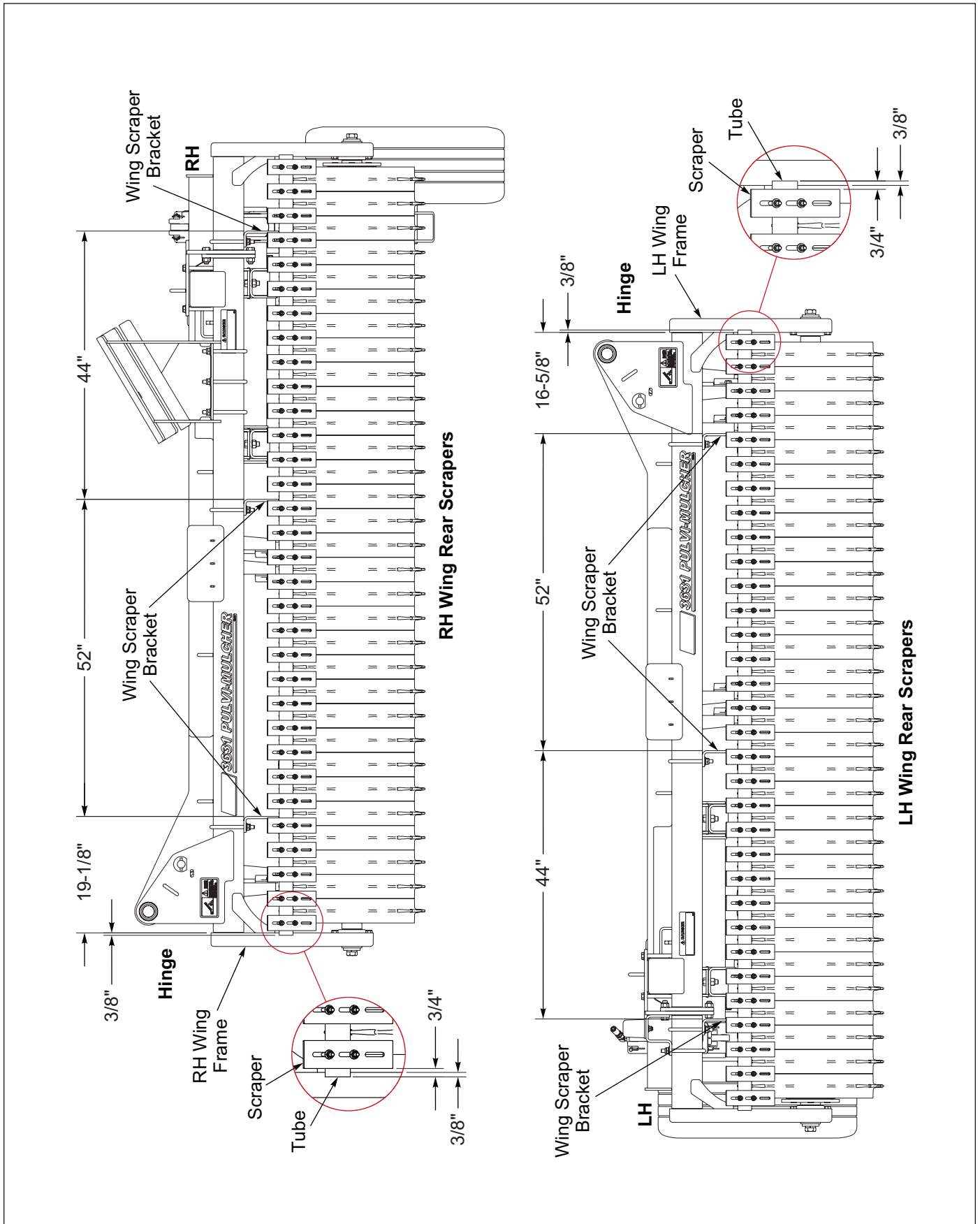

Figure 2-77: Wing Rear Scraper Mounting Dimensions

Center Front Scrapers - Optional

Installation similar to Rear Scrapers, See Page 2-80.

Refer to the Mounting Dimension, See Figure 2-79.

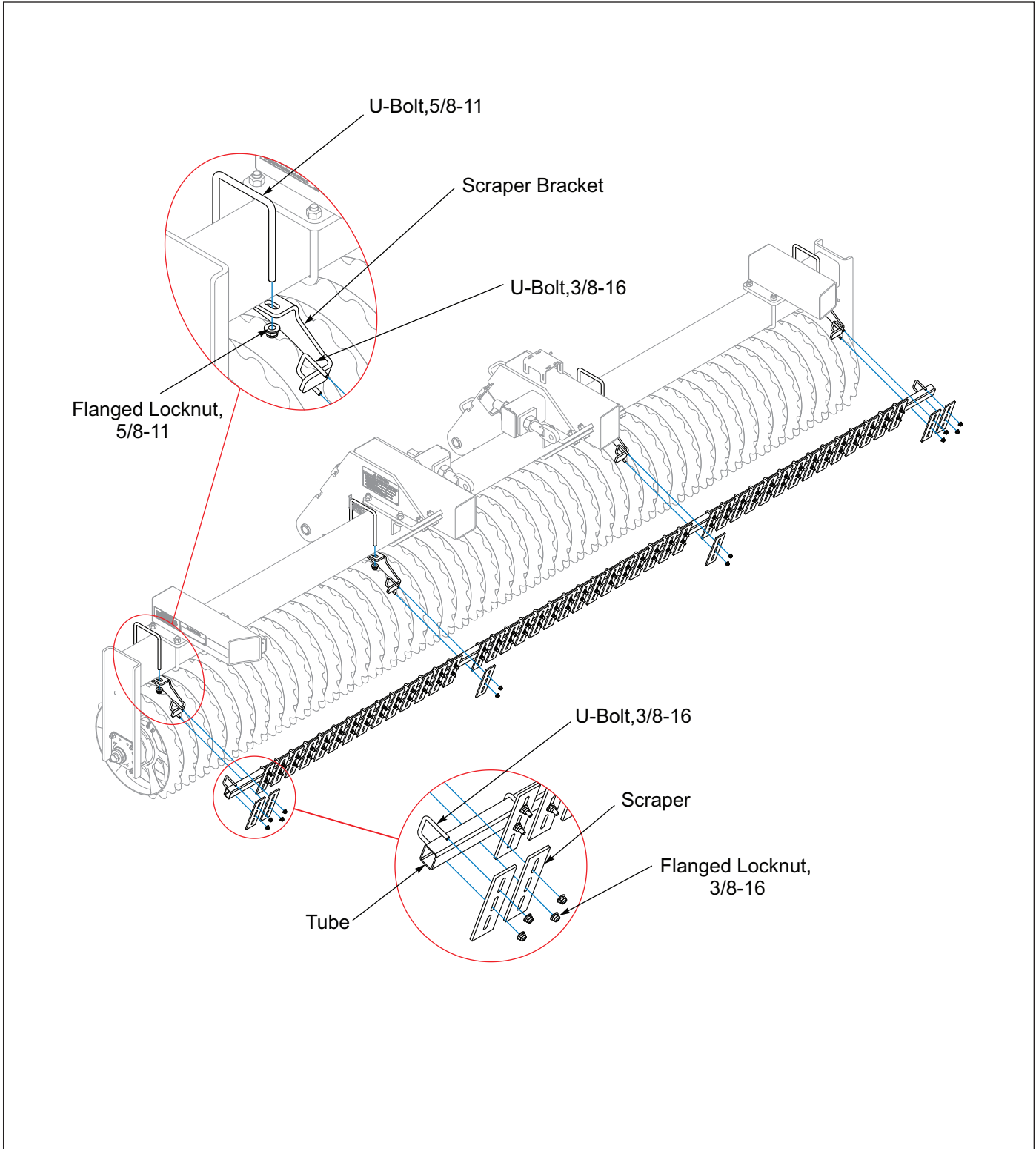

Figure 2-78: Center Front Scrapers Installation - Optional

Center Front Scraper Mounting Dimensions

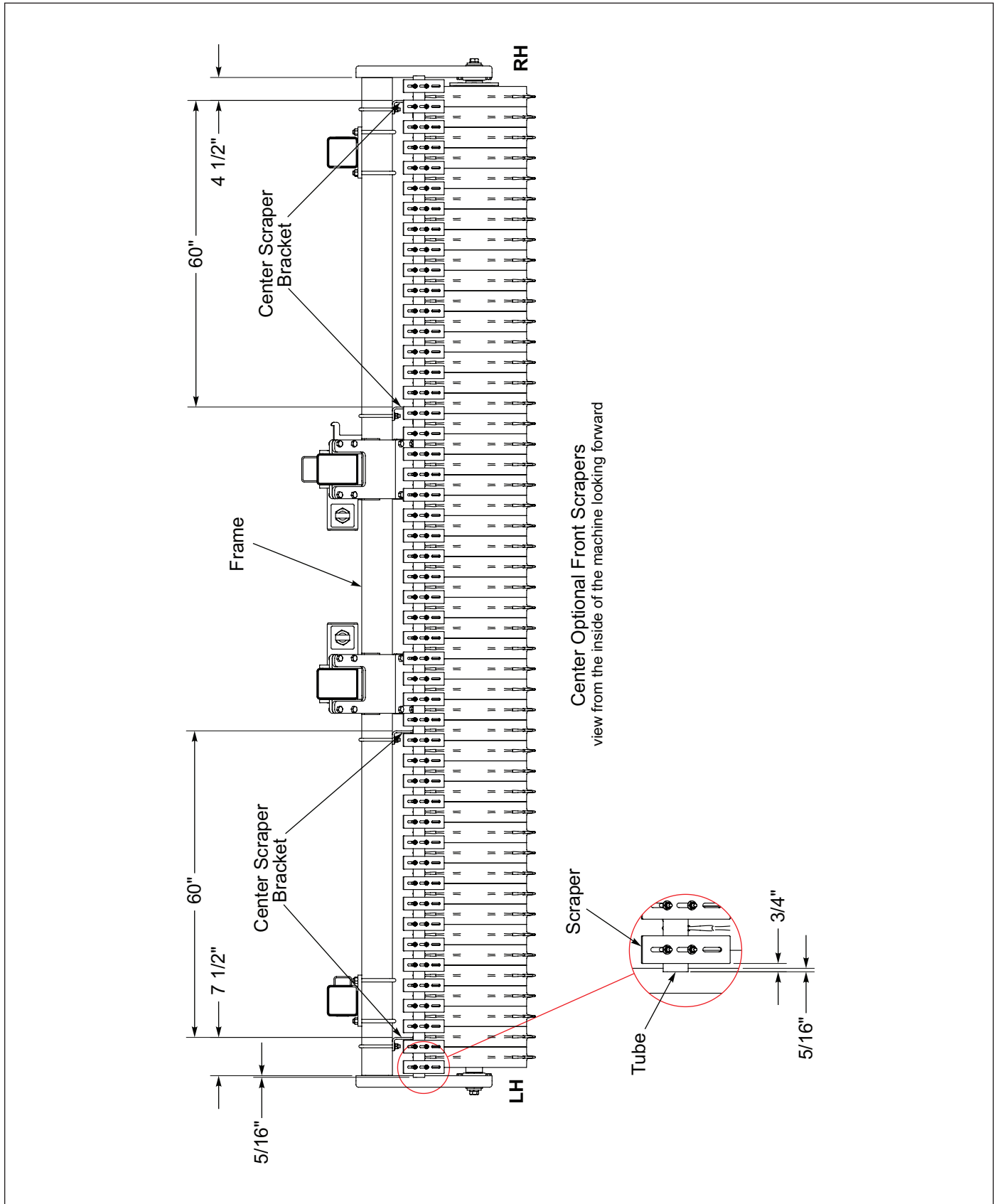

Figure 2-79: Center Front Scraper Mounting Dimensions

Wing Front Scraper Installation - Optional

Installation similar to Rear Wing Scrapers. See Page 2-82.

Refer to the Mounting Dimensions. See Figure 2-81.

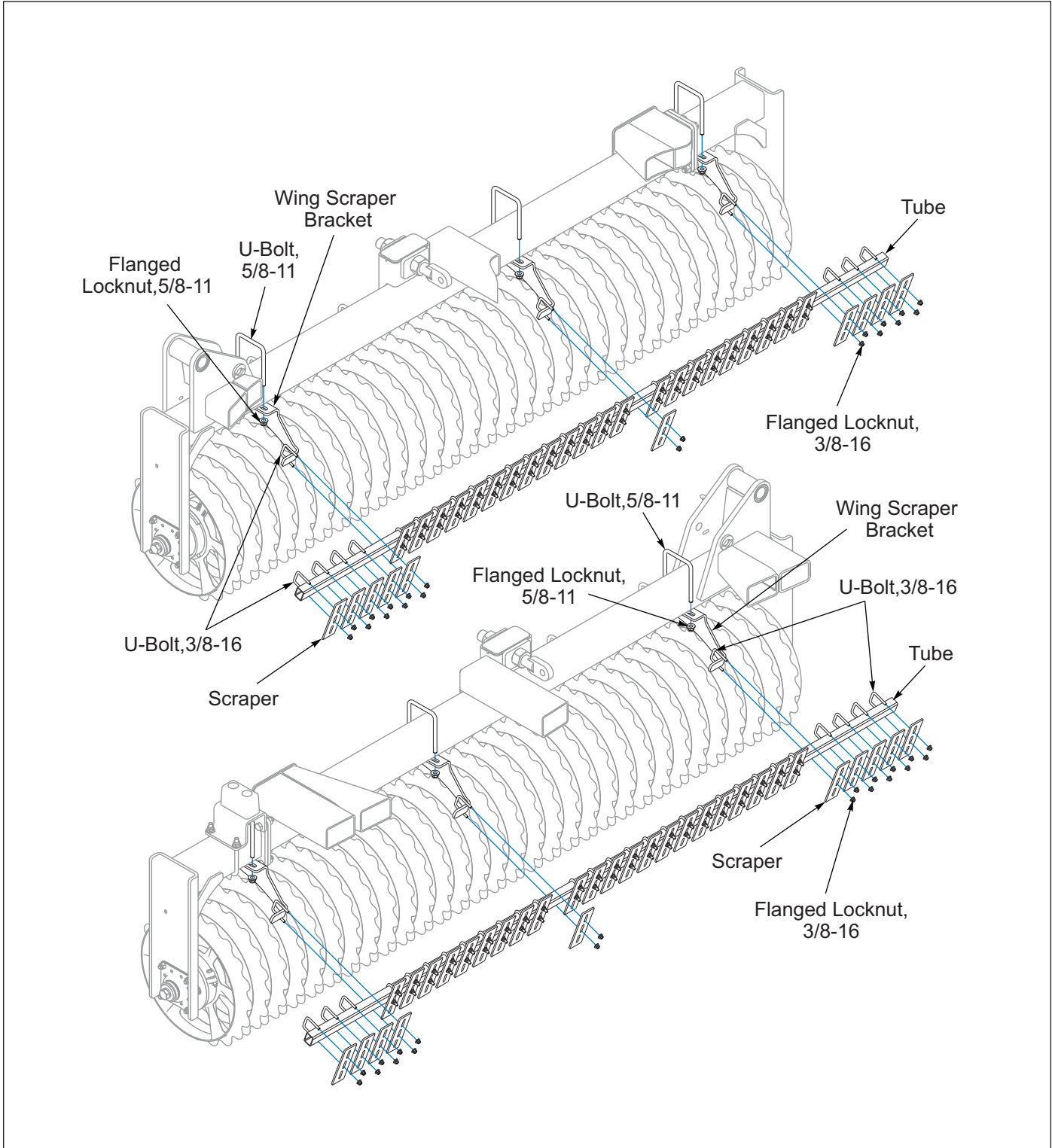

Figure 2-80: Wing Front Scraper Installation - Optional

Wing Front Scraper Mounting Dimensions

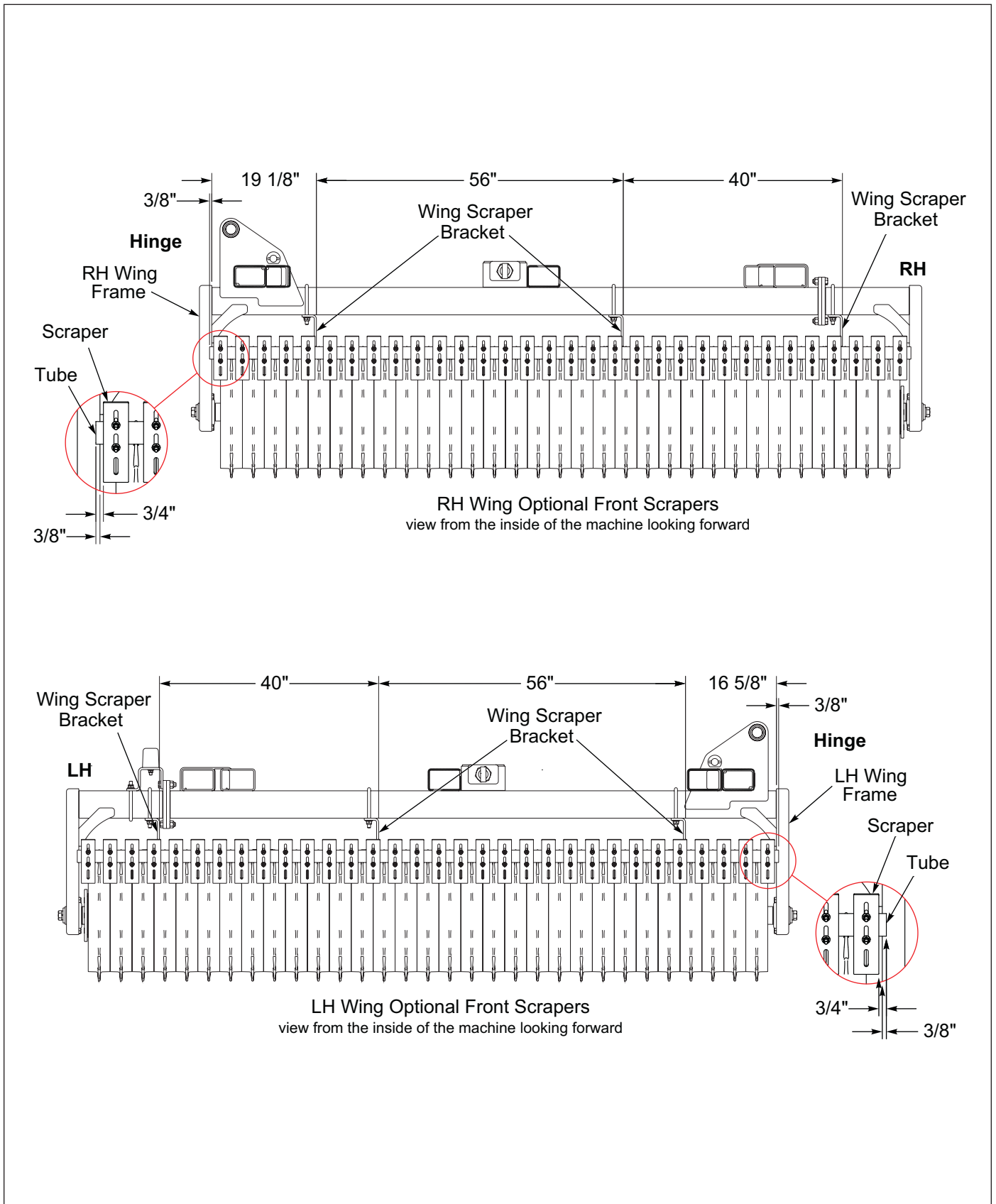

Figure 2-81: Wing Front Scraper Mounting Dimensions

Rear 3-Bar Coil Tine Harrow Without Lift Kit - Optional

Kit Part Number 221599.

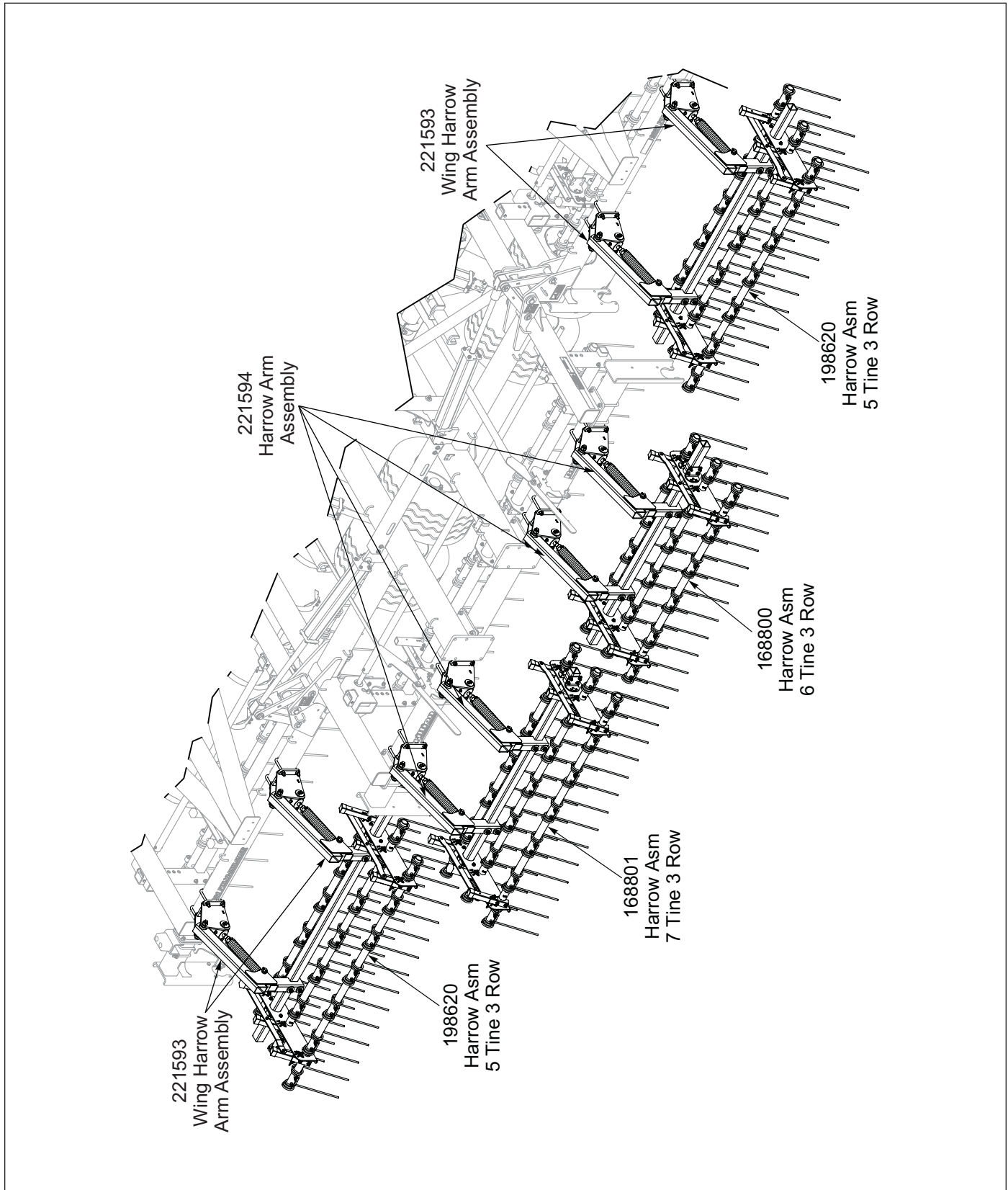

Figure 2-82: Rear 3-Bar Coil Tine Harrow Kit Without Lift - Optional

Rear 3-Bar Coil Tine Harrow Without Lift Installation

CAUTION

Do not work on or under this machine unless securely blocked and supported by a hoist or tractor or by other sufficient means.

WARNING

Do not attempt to lift heavy parts manually. Use a hoist or forklift to move heavy parts into position.

NOTE

Wing Harrow Arms are different than Center Frame Harrow Arms. Center Harrow Arm Assemblies 221594 are used on the Center Frame and Wing Harrow Arm Assemblies 221593 are used on the Wing Frames.

Refer to **Figures 2-85 and 2-86** for the Harrow Arm positioning.

1. Unfold, lower the unit to the ground.
2. Position Harrow Arm Assemblies on the Center Frame Rear Roller Tube or Wing Frame Rear Tube. Secure with 3/4-10 U-Bolts and Locknuts. See **Figure 2-83**.

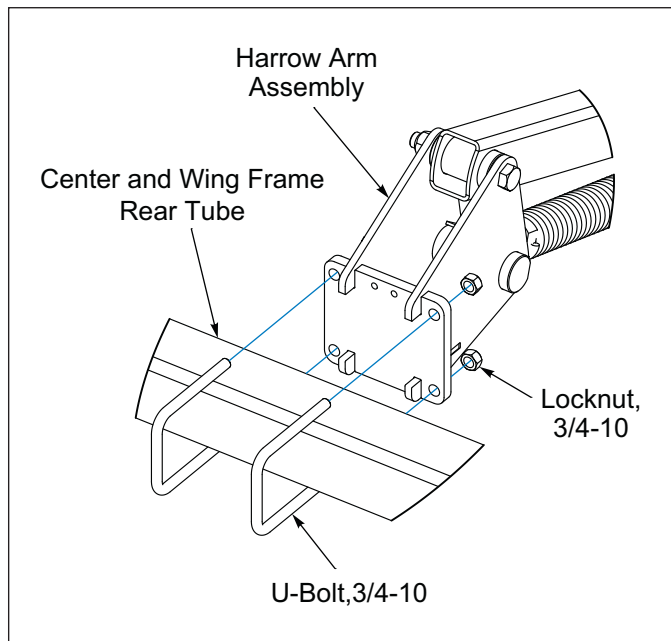

Figure 2-83: Harrow Arm Installation

3. Attach the Harrow Assemblies to the Harrow Arm Assemblies by placing the Harrow Assembly 3 x 3 tube into the Arm Notch. Position 5/8-11 U-Bolt onto 3 x 3 tube and through the Harrow Arm Assembly. Secure with Thick Washers and Flange Locknuts. See **Figure 2-84**.

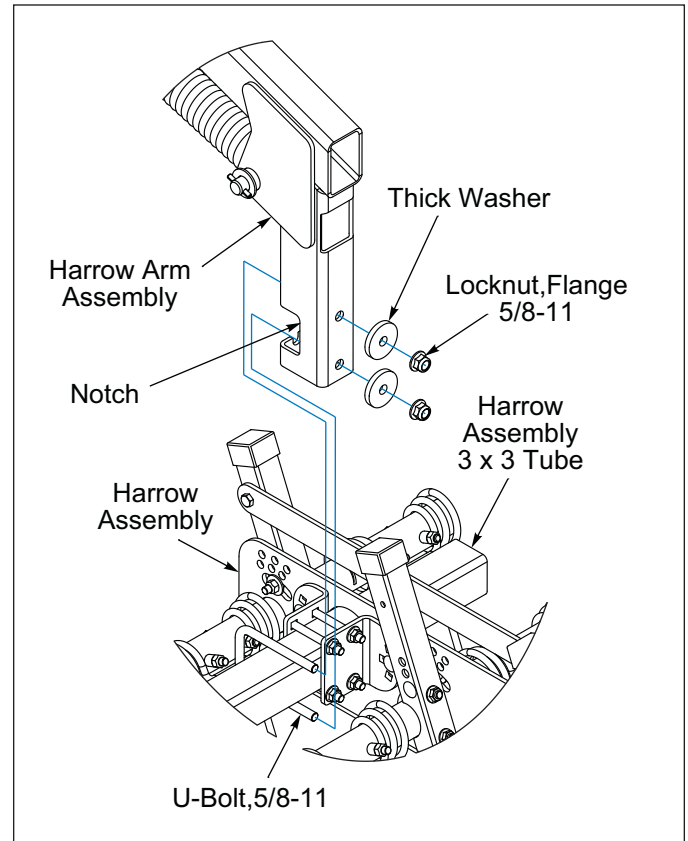

Figure 2-84: Harrow Assembly to Harrow Arm

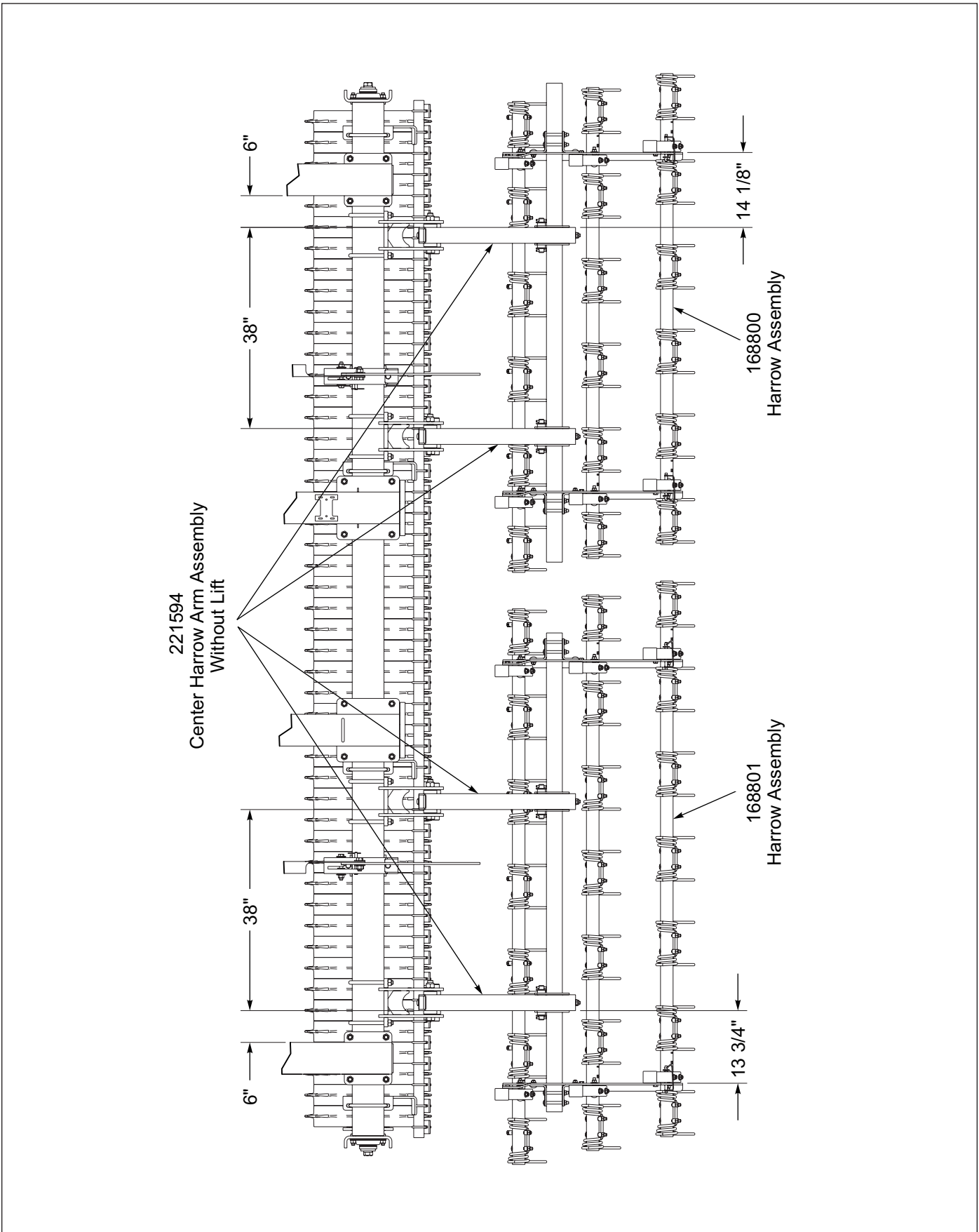

Figure 2-85: Center Rear Harrow Mounting Dimensions - Without Lift

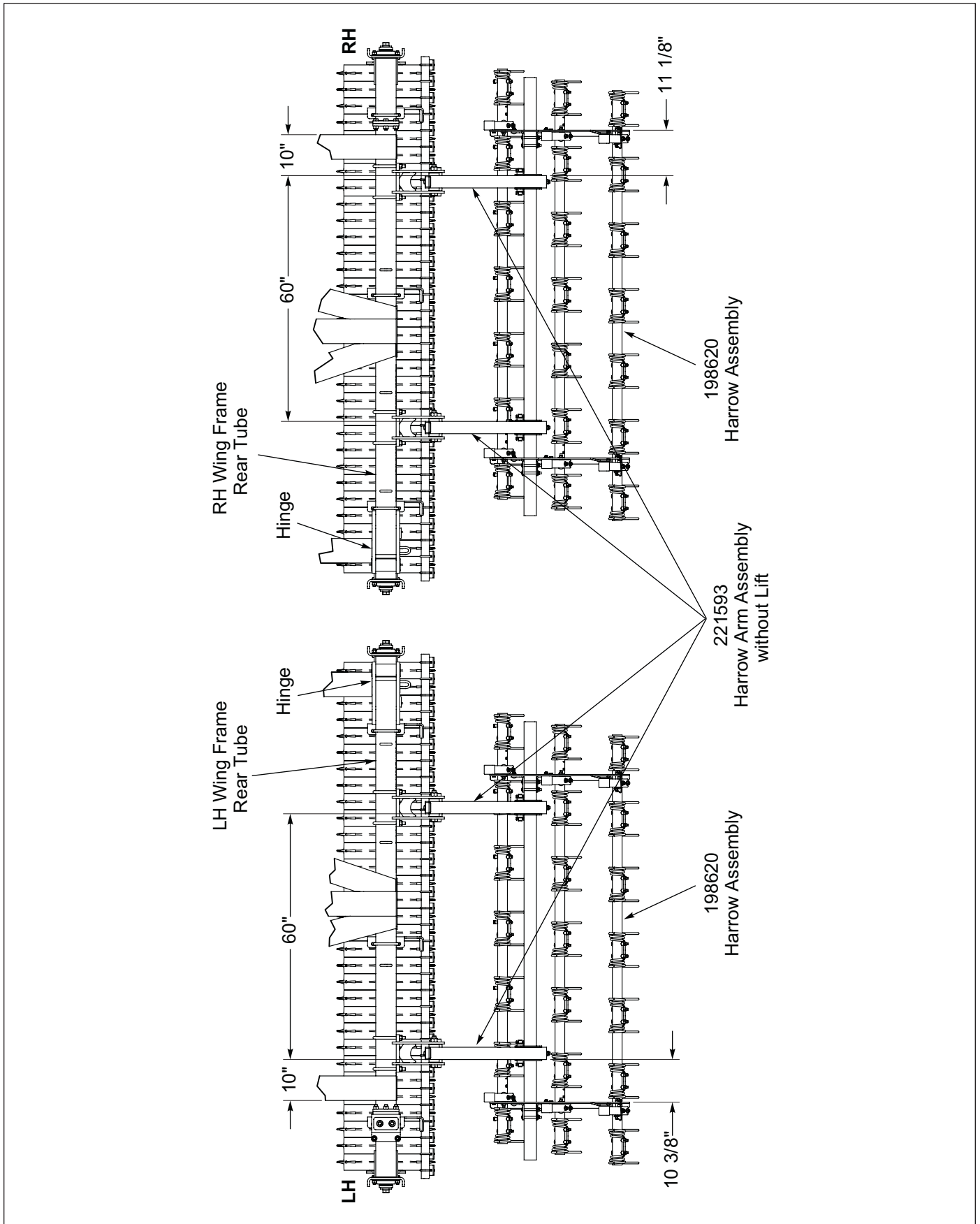

Figure 2-86: Rear Wing Harrow Mounting Dimensions - Without Lift

Rear 3-Bar Coil Tine Harrow With Lift Kit - Optional

Kit Part Number 224176

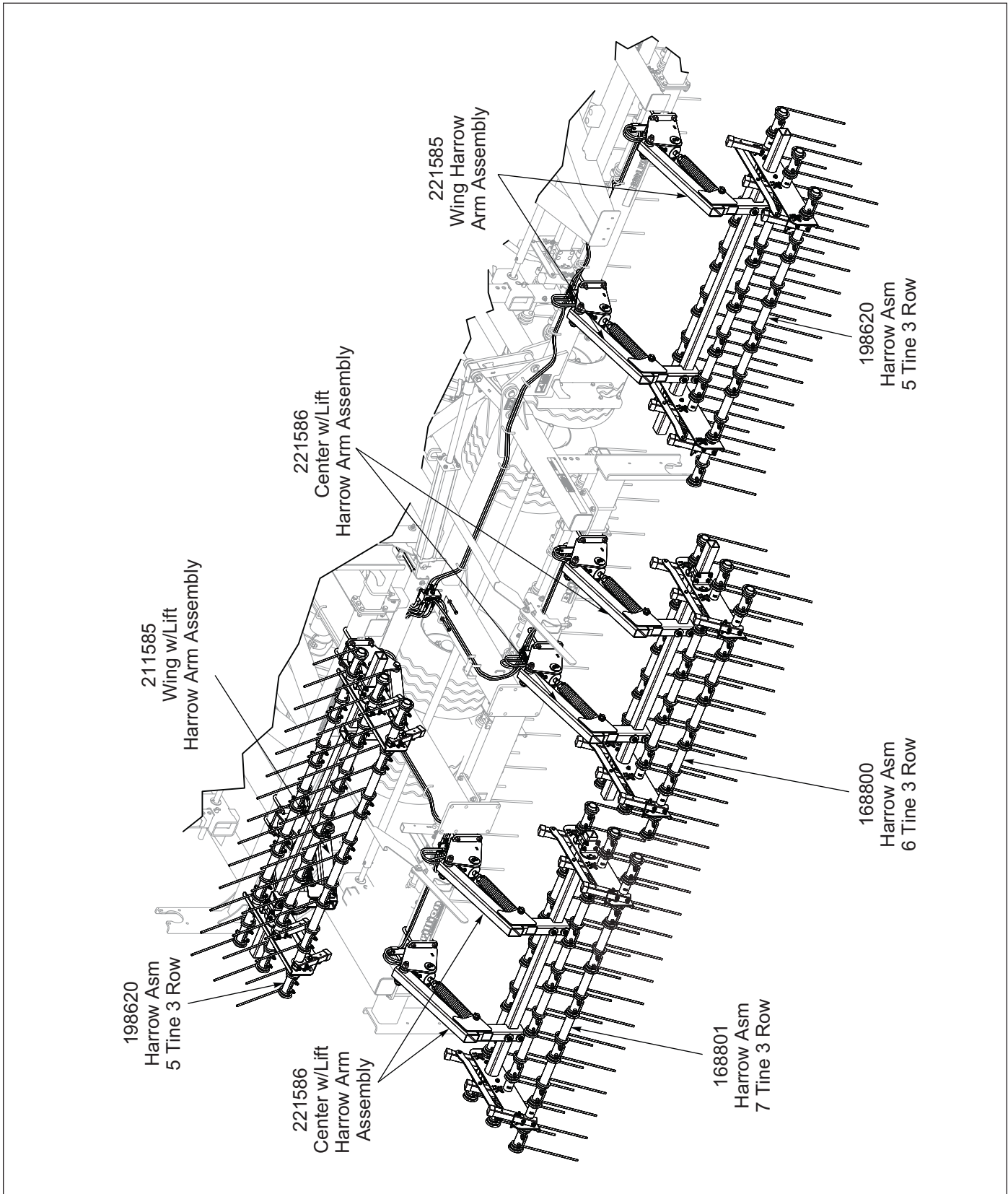

Figure 2-87: Rear 3-Bar Coil Tine Harrow With Lift - Optional

Rear 3-Bar Coil Tine Harrow With Lift Installation

CAUTION

Do not work on or under this machine unless securely blocked and supported by a hoist or tractor or by other sufficient means.

WARNING

Do not attempt to lift heavy parts manually. Use a hoist or forklift to move heavy parts into position.

NOTE

Wing Harrow Arms are different than Center Frame Harrow Arms. Center Harrow Arm Assemblies 221586 are used on the Center Frame and Wing Harrow Arm Assemblies 221585 are used on the Wing Frames.

Refer to **Figures 2-90 and 2-91** for the Harrow Arm positioning.

1. Unfold, lower the unit to the ground.
2. Position Harrow Arm Assemblies onto the back of the Center Frame Rear Roller Tube or Wing Frame Rear Tube. Secure with 3/4-10 U-Bolts and Locknuts. See **Figure 2-88**.

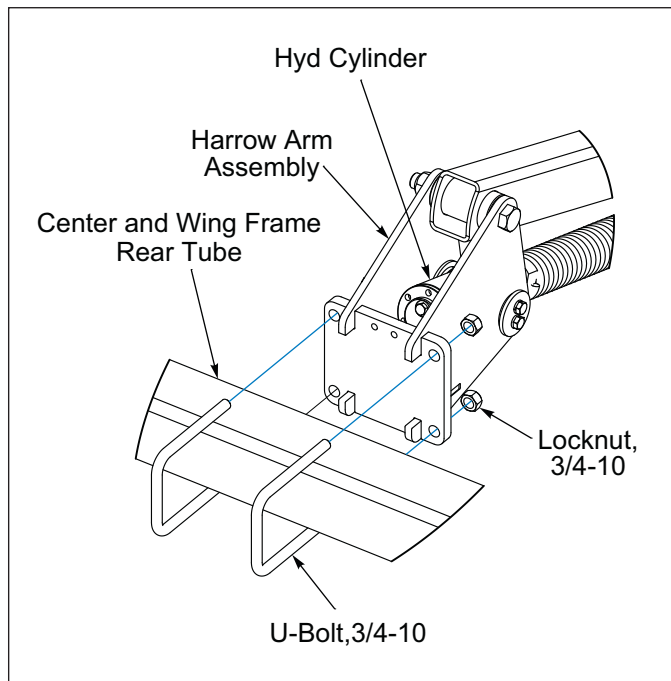

Figure 2-88: Harrow Arm Installation

3. Attach the Harrow Assemblies to the Harrow Arm Assemblies by placing the Harrow Assembly 3 x 3 tube into the Arm Notch. Position 5/8-11 U-Bolt onto 3 x 3 tube and through the Harrow Arm Assembly. Secure with Thick Washers and Flange Locknuts. See **Figure 2-89**.

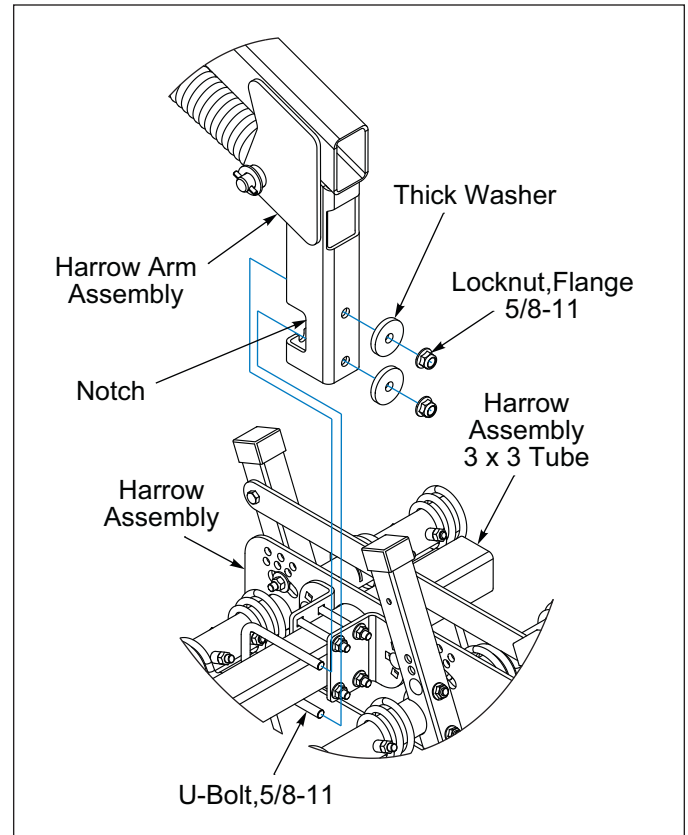

Figure 2-89: Harrow Assembly to Harrow Arm

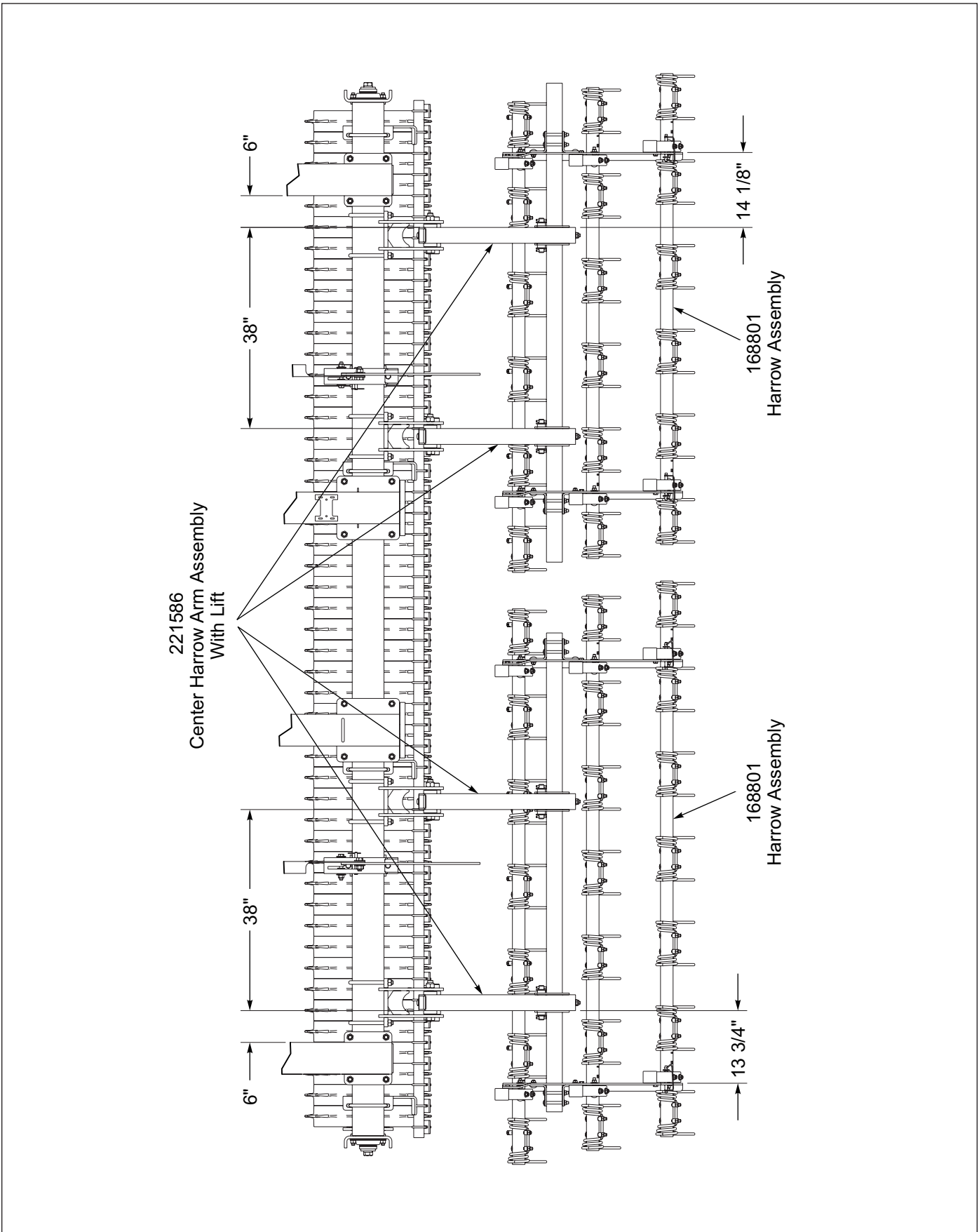

Figure 2-90: Center Rear Harrow Mounting Dimensions - With Lift

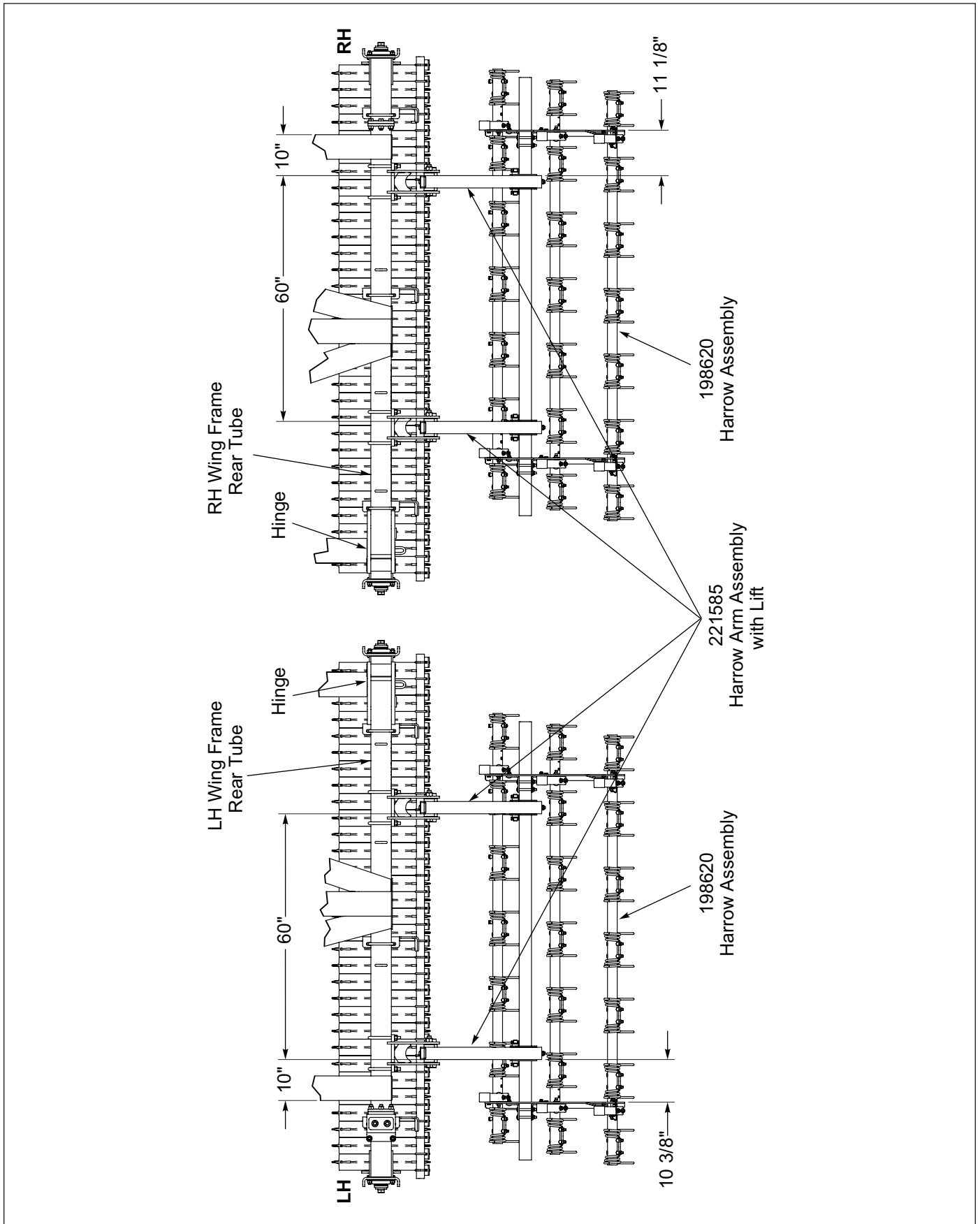

Figure 2-91: Rear Wing Harrow Mounting Dimensions - With Lift

Plumb 3-Bar Coil Tine Harrow With Lift

1. Install 8-Port Manifold to the mount located at the rear of RH Inner 8x6 frame tube with 1/2-13 x 3-1/2 Bolts, Flat Washers and Nut. **See Figures 2-93.**
2. Each Harrow Assembly has a pair of Harrow Arm Assemblies that raise and lower the Harrow Assembly. Attach Bulkhead Plate to the inner Harrow Arm Assembly with 3/8-16 x 1-3/4 Bolts and Flanged Locknuts. Attach Hose Clamp Mount to the outer Harrow Arm Assembly with a 3/8-16 x 1-3/4 Bolt and Flanged Locknut.
3. Install Fittings into 8-Port Manifold, Bulkhead Plate and Hydraulic Cylinders. **See Figure 2-94.** Hoses for the Left side of the machine, route them from the 8-Port Manifold through the Rear Wing Rest. Attach hoses to the Fittings. **See Figures 2-93 and 2-94.** On each side wrap both hoses near the Hinge Pin area with 26 inch Hose Wrap.
4. Secure Harrow Arm Assembly outer Cylinder Hoses to the Hose Clamp Mount with Hose Clamp, 3/8-16 x 1-3/4 Bolts and Flanged Locknuts.
5. From the front of the 8-Port Manifold route the 3/8" hoses through the Rear Wing Rest and down the Center Frame RH Inner 8x6 Tube, under the Fold/Down Pressure Valve and down the RH side of the Drawbar. Secure all hoses with tie wraps. Wrap the Harrow Hoses near the Tractor Tips with Red Hose Wrap.

Purge Hydraulic Rear 3-Bar Coil Tine Harrow With Lift



WARNING

Escaping hydraulic fluid can cause serious personnel injury. Relieve system pressure before repairing, adjusting, or disconnecting. Wear proper hand and eye protection when searching for leaks. Use cardboard instead of hands. See Figure 2-87. Keep all components (cylinders, hoses, fittings, etc.) in good repair.

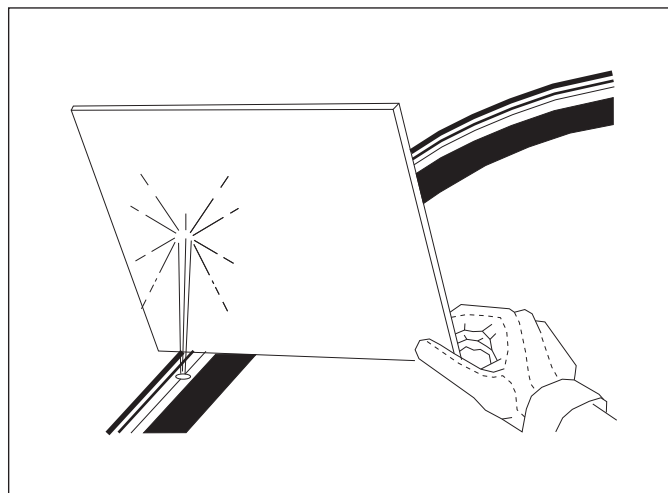

Figure 2-92: Hydraulic Leak Detection

Ensure tractor reservoir is full of manufacturer's recommended oil. Extend Harrow Cylinders. Recheck tractor reservoir. Completely extend and retract Harrow Cylinders 5-6 times to purge air from the Circuit. Do not loosen hoses or fittings. Recheck tractor reservoir oil level.

Harrow Circuit raised approximate oil requirement:
1.1 gallons

Harrow Circuit lowered approximate oil requirement: 1.0 gallons

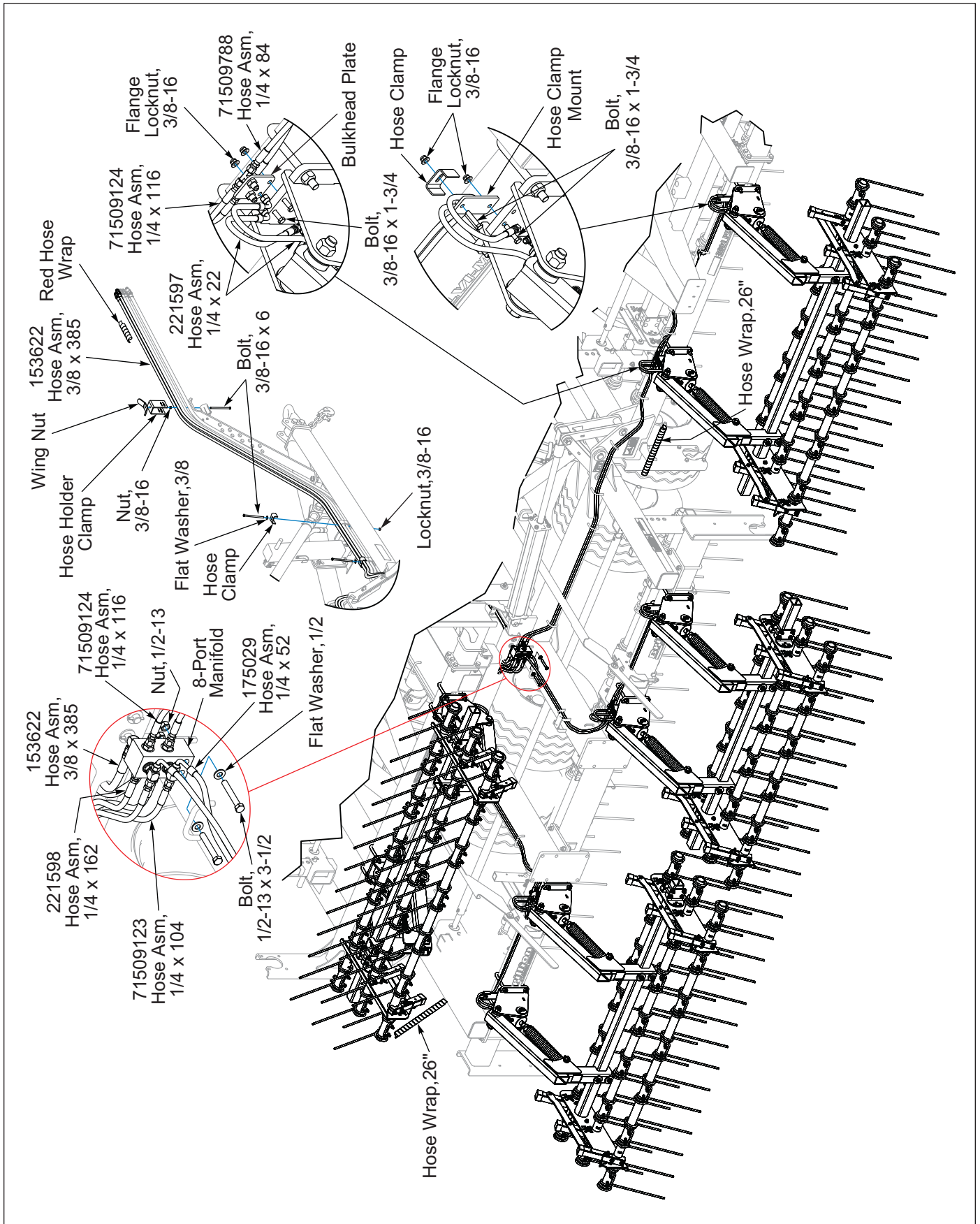

Figure 2-93: Harrow Kit, 3-Bar Coil Tine With Lift - Optional - Layout

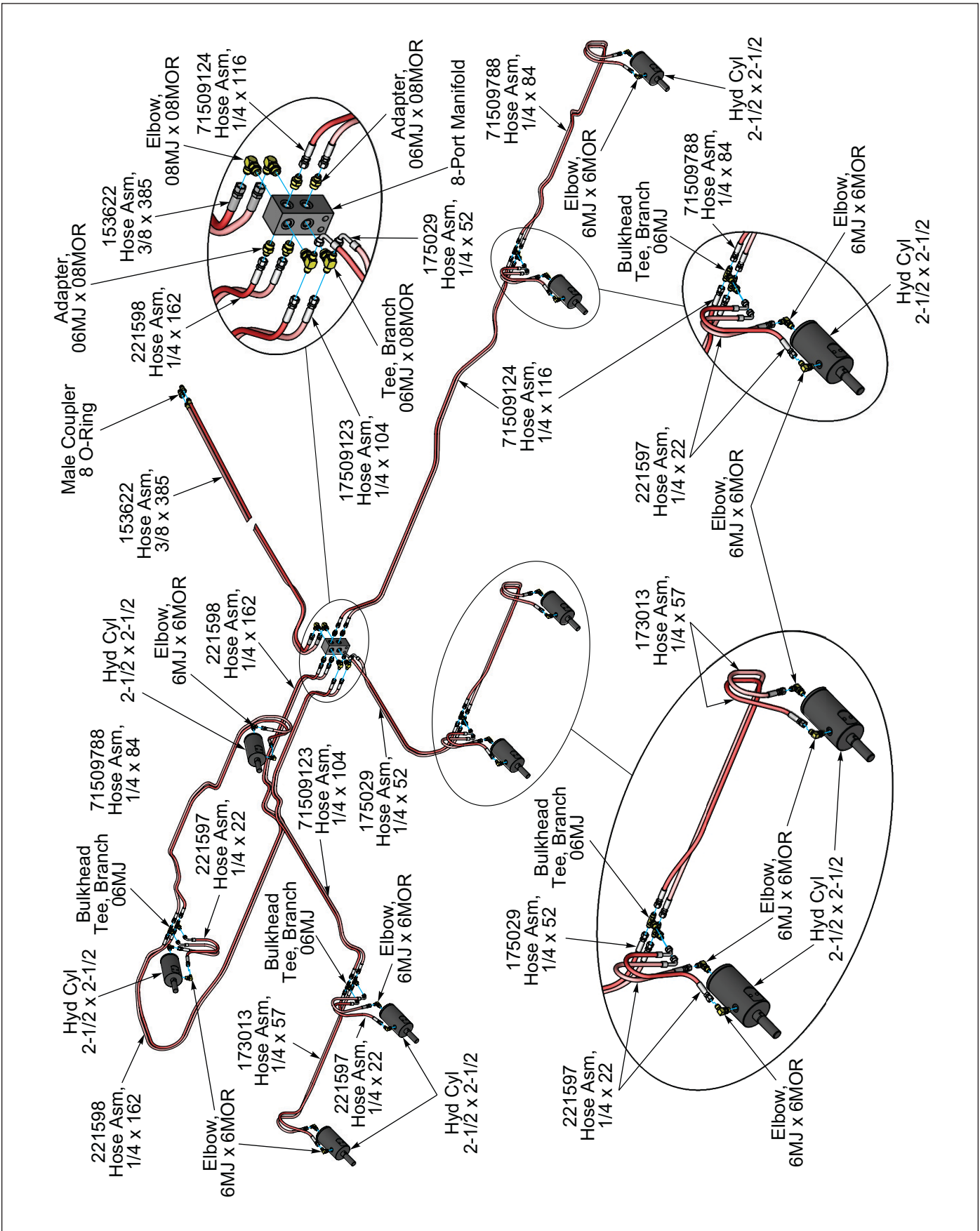

Figure 2-94: Harrow Kit, 3-Bar Coil Tine With Lift - Optional - Hydraulic Schematic

Land Leveler Installation - Optional

Kit Part Number 221591

1. Attach the Leveler Mounts to the Center Frame Front Roller Frame Tube using 3/4-10 x 6-13/16 x 7-3/4 U-Bolts and to the Front Wing Frame Tube using 3/4 x 5-25/32 x 7-1/4 U-Bolts. Secure with Flat Washers and Locknuts. **See Figures 2-95, 2-97 and 2-97.**
2. Slide the Center and Wing Levelers up into the mount slot and insert 1/2-13 x 3 Bolt. On the opposite side place the 1 x 1-1/2 Bushing over the bolt and into the opening. Secure with Flat Washer and Locknut.
3. Insert 3/8 x 2-1/2 Cotter Pin into the upper hole and spread.

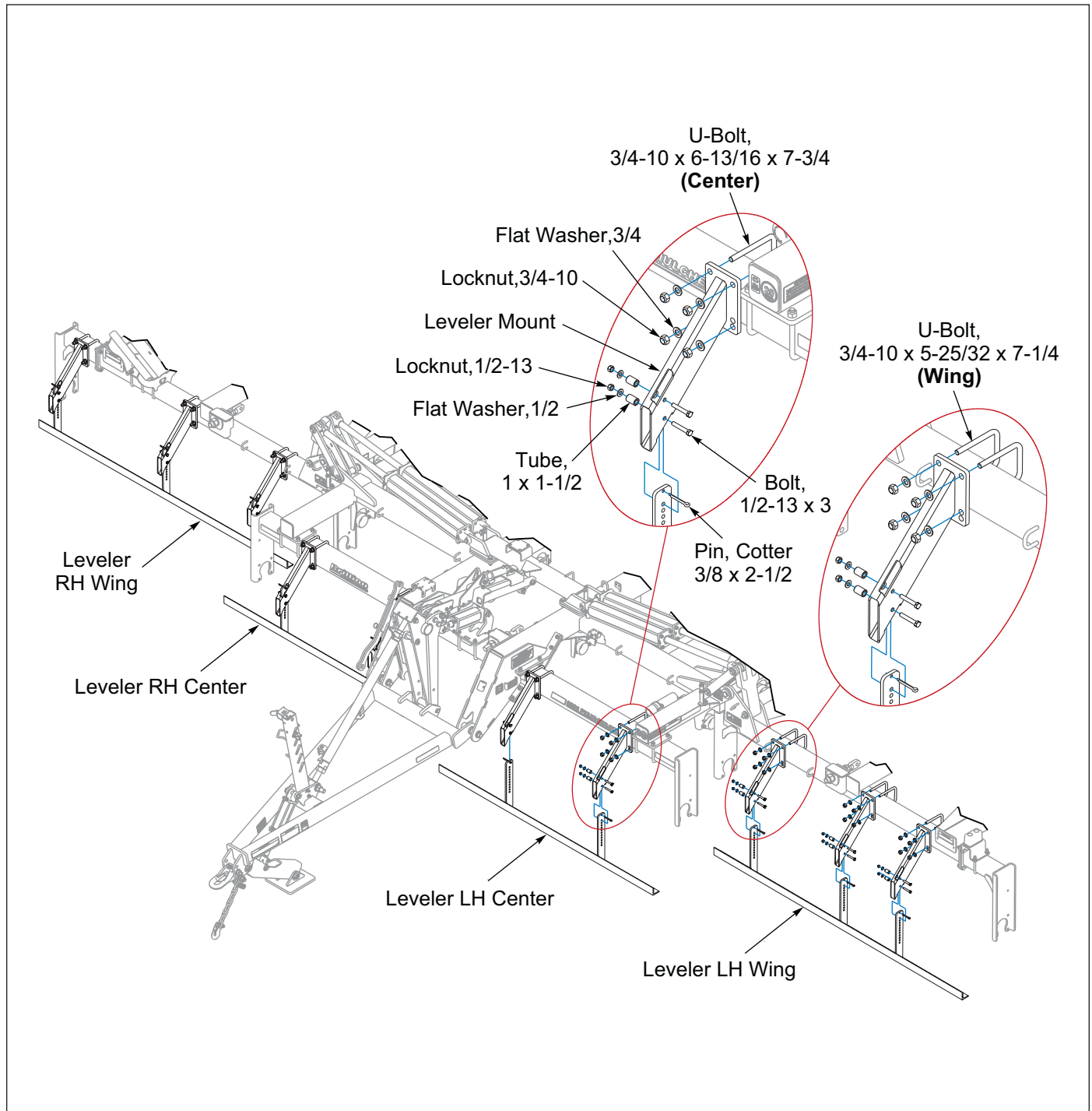

Figure 2-95: Land Leveler Installation - Optional

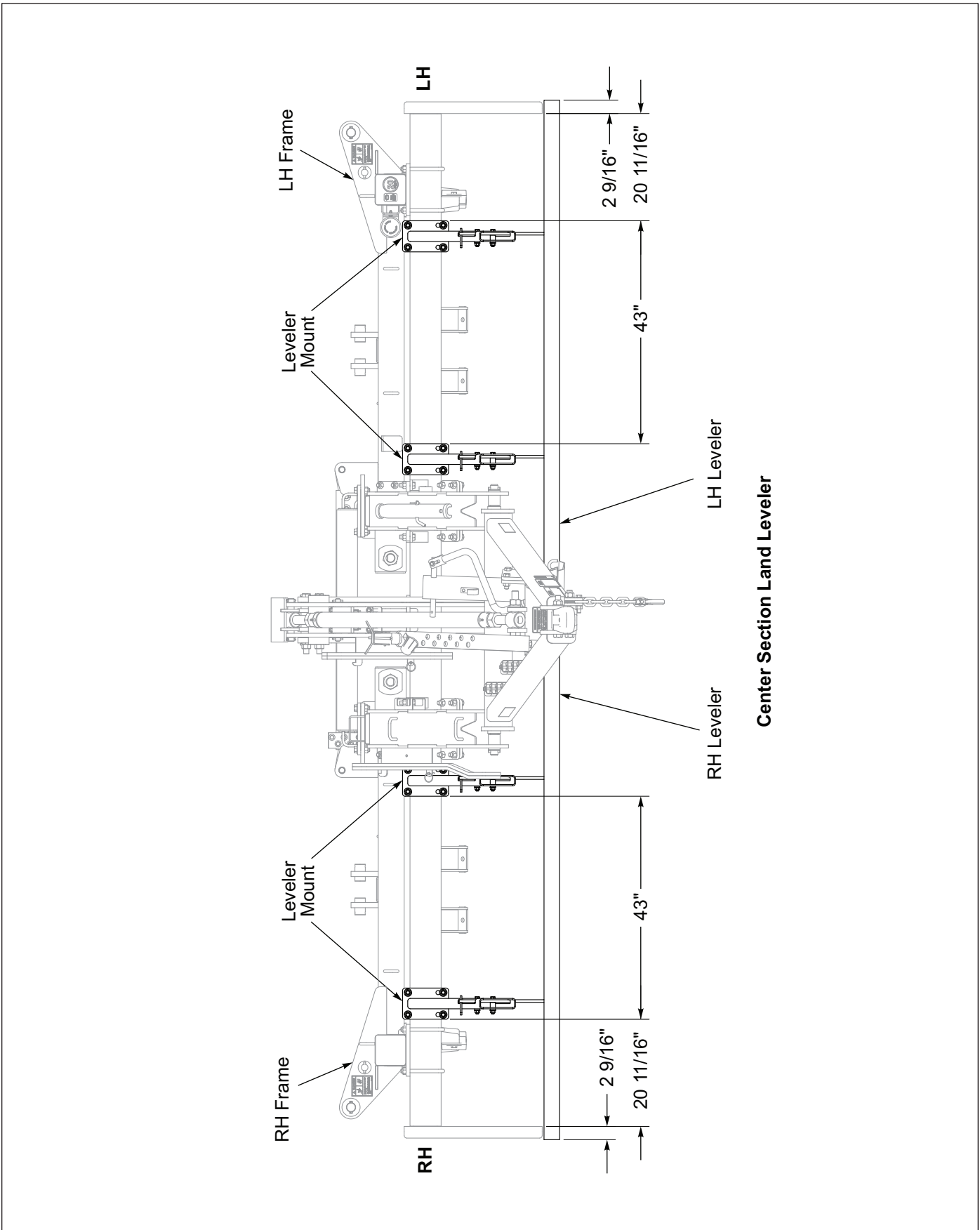
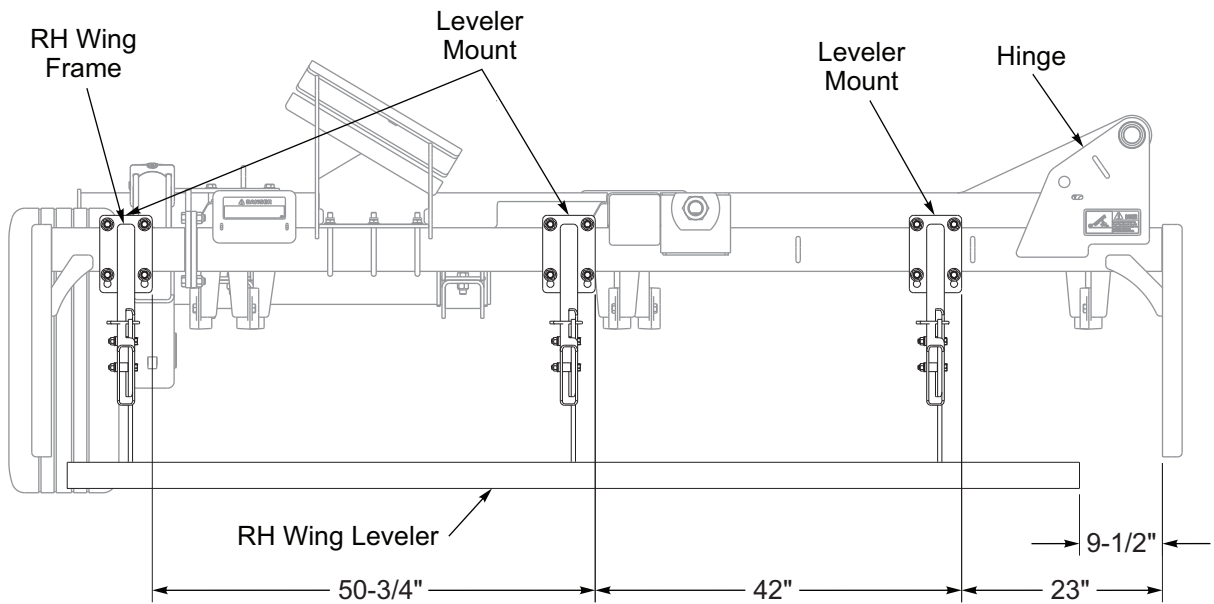
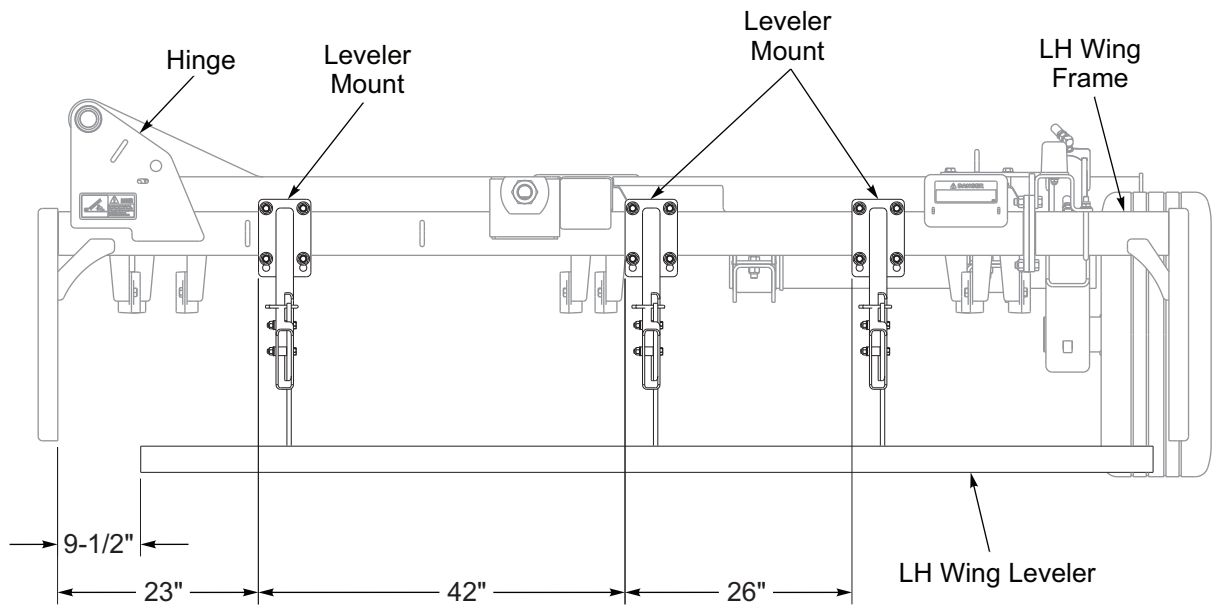

Figure 2-96: Land Leveler Center Mounting Dimensions



RH Wing Land Leveler



LH Wing Land Leveler

Figure 2-97: Land Leveler Wing Mounting Dimensions

Center V-Leveler Installation - Optional

Kit Part Number 221592

V-Leveler Wing and Land Leveler Wing Installation is similar. Refer to Wing Placement Dimensions, **See Figure 2-97.**

1. Place the cutout of the V-Leveler Bracket on top and center it on the Drawbar Rear Cross Tube. Secure with 5/8-11 U-Bolts and Locknuts. **See Figure 2-98.**
2. Position the Leveler Links on each side of the V-Leveler Bracket and insert 1 x 7 Pin. Place a Flat Washer on each side of the Pin and secure with 5/16 x 2 Roll Pin and Klik Pin.
3. Lift the V-Leveler up and align the single bottom hole of the Link with the V-Leveler and insert 1 x 8 Pin. Place a Flat Washer on each side of the Pin and secure with 5/16 x 2 Roll Pins.
4. Mount the two longer Leveler Mounts to the Center Frame Front Roller Frame Tube directly above the V-Leveler Mounting Straps with 3/4-10 x 6-13/16 x 7-3/4 U-Bolts, Flat Washers and Locknuts. **Do Not** tighten at this time.
5. Lift the V-Leveler Strap into the longer Leveler Mount opening and insert 1 x 3 Clevis Pin. Place a Flat Washer on the Pin and secure with Hair Pin Cotter.
6. Adjust the Longer Leveler Mounts on the Front Roller Frame Tube accordingly and tighten the 3/4-10 U-Bolts. Install a 3/8 x 2-1/2 Cotter Pin at the top of each V-Leveler Strap.

Wing V-Leveler Installation

1. Attach the Leveler Mounts to the Front Wing Frame Tube with 3/4-10 x 5-25/32 x 7-1/4 U-Bolts, Flat Washers and Locknuts. **See Figure 2-98.**
2. Slide the Wing Leveler Bar up into the mount slot and insert 1/2-13 x 3 Bolt.
3. On the opposite side place the 1 x 1-1/2 Bushing over the bolt and into the opening secure with Flat Washer and Locknut. Insert 3/8 x 2-1/2 Cotter Pin into the upper hole and spread.

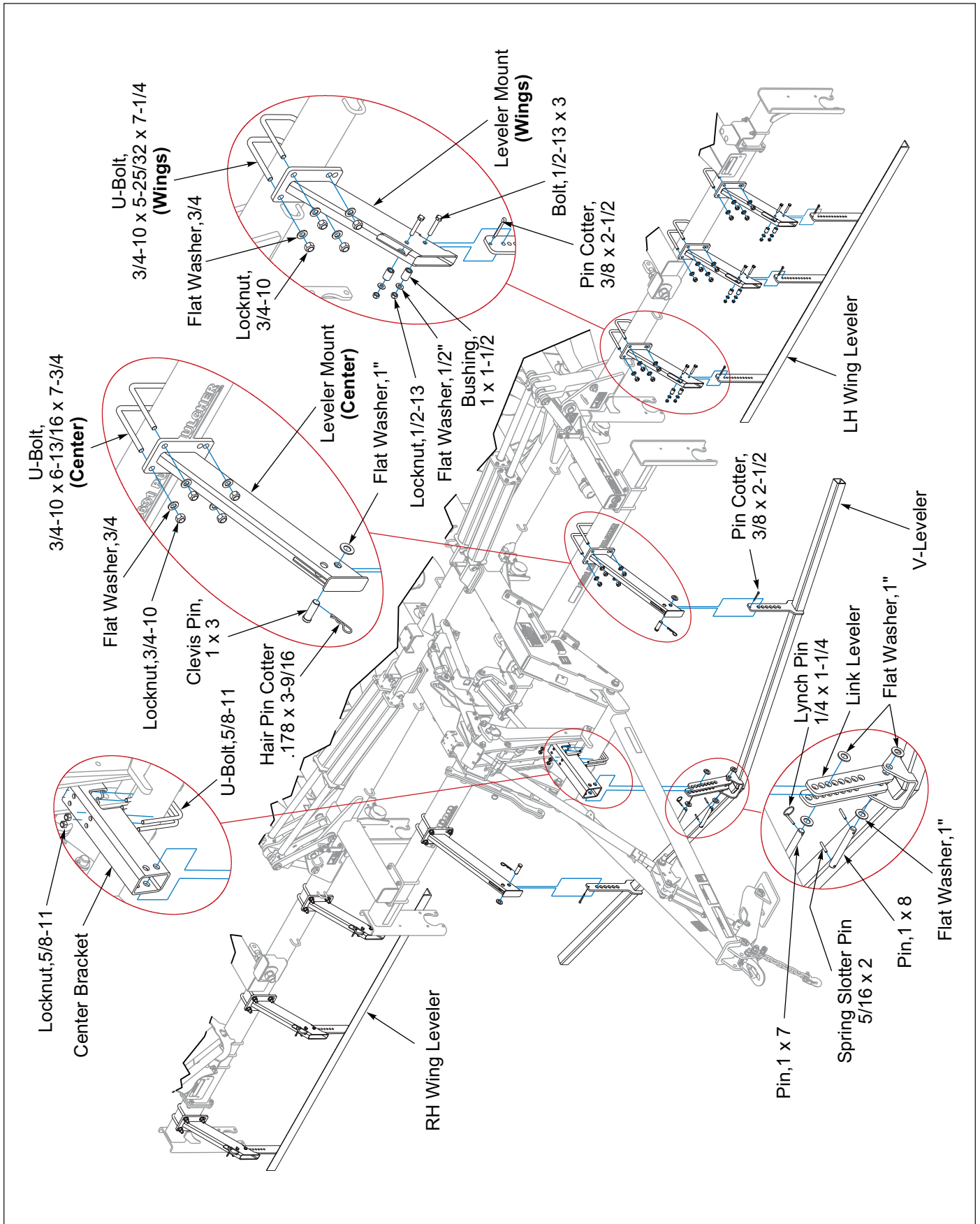

Figure 2-98: V-Leveler Installation - Optional

Rear Hitch Installation - Optional

Kit Part Number 214025

1. Position the Rear Hitch to the rear frame hitch plates, insert twelve 3/4-10 x 3 Bolts secure with Locknuts. **See Figure 2-99.**
2. Slide the two Bulkhead Adapters into the bulkhead plate and tighten. Attach the two female Couplers to the Bulkhead Adapters.
3. Attach the two 3/8 Hoses and tighten. **See “Hydraulic Fitting Torque Specifications” on page 4-2.** Route the Hose Assembly along the inner

frame tube with the other Hydraulic Hoses to the front of the drawbar.

4. Secure with tie wraps.
5. Insert the Tandem Harness Adapter into the bulkhead plate and secure with two 1/4-20 x 1 Bolts and Locknuts.
6. Hook up Tandem Haul Adapter to tractor side of Enhanced Lighting Module.

NOTE

All wires/hoses must be firmly attached to machine frame members so they do not sag or become torn loose by field debris.

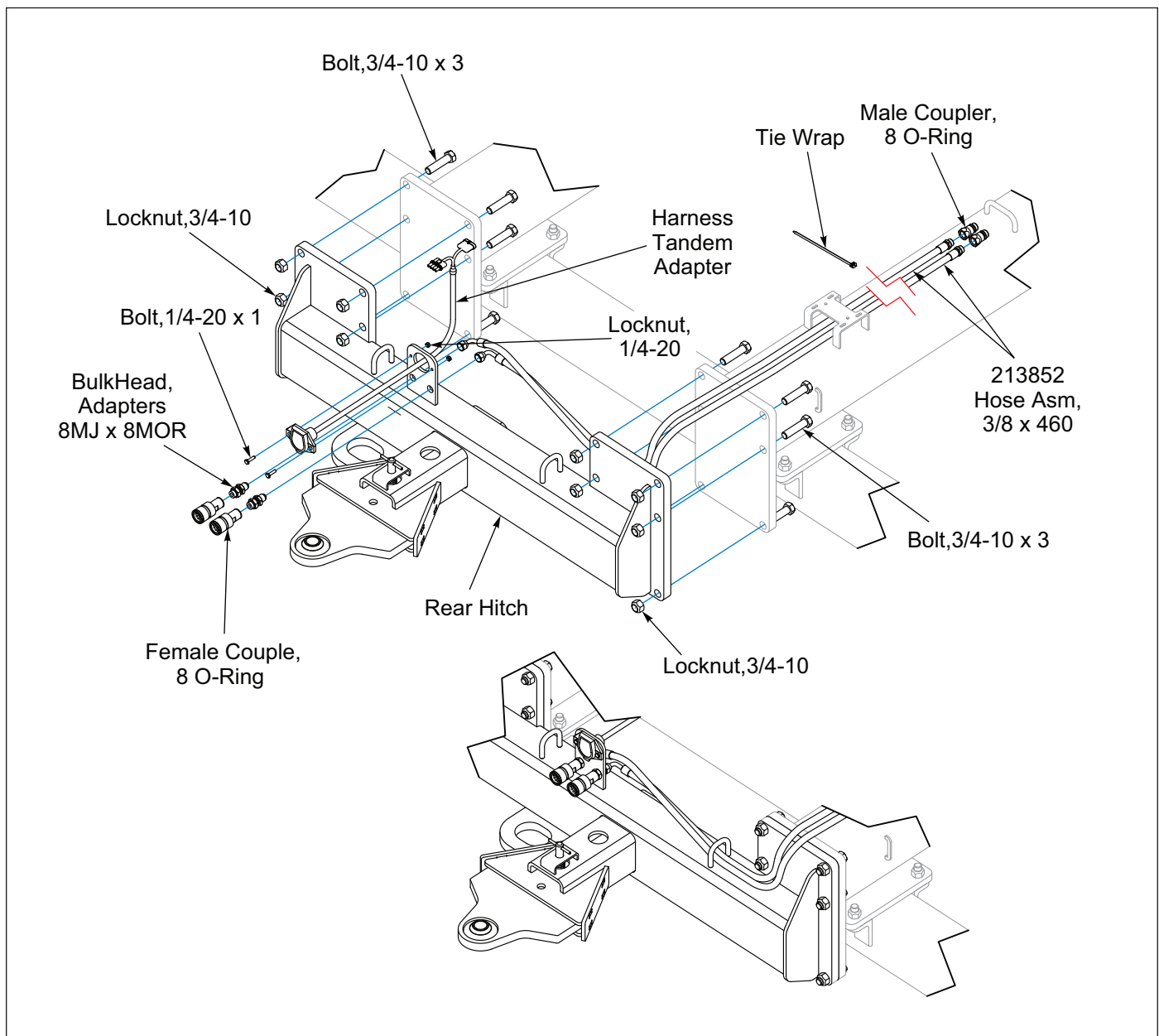

Figure 2-99: Rear Hitch Installation - Optional

Operation

**DANGER**

Never allow anyone to ride on the 3631 Pulvi-Mulcher at any time. Allowing a person to ride on the machine can inflict serious personal injury or death to that person.

**DANGER**

Always lock the tractor drawbar in the center position when transporting the unit. Failure to do so can result in serious injury or death and cause damage to the equipment.

**WARNING**

All hydraulically elevated equipment must have cylinder lockouts installed or be lowered to the ground, when servicing or when equipment is idle. Failure to take preventive measures against accidental lowering can result in serious personal injury.

**DANGER**

When transporting the unit, place cylinder lockouts in the transport lock position after fully extending the cylinders. Insert the lockout pins to secure the cylinder lockouts. Failure to lockout the cylinders can cause the unit to settle during transport, which can result in serious injury or death and cause damage to the equipment.

**CAUTION**

When transporting farm implements on public roads, it is the responsibility of the operator to abide by state and local laws concerning wide loads, speed, safety emblems and safety lighting equipment. Drive at safe speeds, particularly when rounding corners, crossing rough ground or driving on hillsides, to prevent tipping the tractor.

Tractor Preparation

The Brillion 3631 Pulvi-Mulcher is designed to be pulled by tractor equipped with a double lip or clevis type hitch. If your tractor is not equipped as such, purchase the hitch from your local tractor dealer. If implement is equipped with the clevis option, this should be removed. The clevis option is only for transport use.

Before attaching the implement, prepare the tractor as follows:

1. Inflate the tractor tires and add ballast according to the tractor operator's manual.
2. Lock the tractor drawbar in the center position.

Pulvi-Mulcher Preparation

1. Prior to operating the 3631 Pulvi-Mulcher, inspect it thoroughly for good operating condition.
2. Replace worn or missing parts.
3. When the machine is new, check the bolt tightness after a few hours of operation. Tighten any loose nuts or bolts. Check the Lift Wheel Lug Bolts daily.
4. Check the Lift Wheel tire inflation. Inflate all tires equally to avoid side draft. Follow the tire manufacturer's recommended pressures listed on the sidewall of the tires.



DANGER

Do not allow any bystanders to stand between the tractor and the implement while backing up to the implement.

Attaching to the Tractor

1. Align the tractor drawbar with the machine. Raise or lower the Hitch, as needed, using the Jack. Attach the unit with proper size Hitch Pin. **See Table 3-1.**
2. **For Hydraulic Jack:** Be certain Hydraulic Jack is completely raised before setting machine in motion.
For Manual Jack: The 3631 Jack has a Drop Leg. Be sure Drop Leg is completely raised and Crank Adjustment is completely raised. Move handle to storage clip.
3. Clean all hydraulic couplings and attach to the tractor. Be sure to attach case drain hose to tractor. See tractor operator's manual for correct port.
4. **For Hydraulic Transport Locks:** Double check locks are engaged at the Lift Cylinders and Hitch Leveler. **See Figures 3-7 and 3-8.**
For Manual Transport Locks: Fully extend the Hydraulic Lift Wheel Cylinders, and place the Cylinder Lockouts in the Transport Lock Position over the Cylinder Rods. Secure the Lockouts with the Lockout Pins. **See Figures 3-5 and 3-6.**
5. Attach Safety Chain to tractor allowing plenty of movement for turning both directions. The Safety Chain should latch securely to prevent it coming loose. **See Figure 1-2.**
6. Plug the 7-Pin Connector to tractor outlet, routing cable by avoiding pinch points.
 - Make sure the tractor has a good clean receptacle, free of dirt and corrosion.
 - Make sure the 7-Pin Connector is inserted ALL the way in. With tighter fitting pins, operator may think the connector is all the way in, but really isn't.
 - Make sure the tractor receptacle cover latches over the keyway on the 7-Pin Connector to hold the connector in place.
 - If an operator plugs in the 7-Pin Connector, but the lights do not seem to work right, check the above items to make sure there is a good connection with the 7-Pin Connector.

Table 3-1: Hitch Pin Size

DRAWBAR CAT	Min Pin Size	Max PTO HP
3	1-1/2" (38mm)	248 (185 Kw)
4	2" (50mm)	402 (300 Kw)
5	2-3/4" (70mm)	670 (500 Kw)

Hydraulic Lift System



WARNING

Escaping hydraulic fluid can cause serious personnel injury. Relieve system pressure before repairing, adjusting, or disconnecting. Wear proper hand and eye protection when searching for leaks. Use cardboard instead of hands (See Figure 3-1.) Keep all components (cylinders, hoses, fittings, etc.) in good repair.

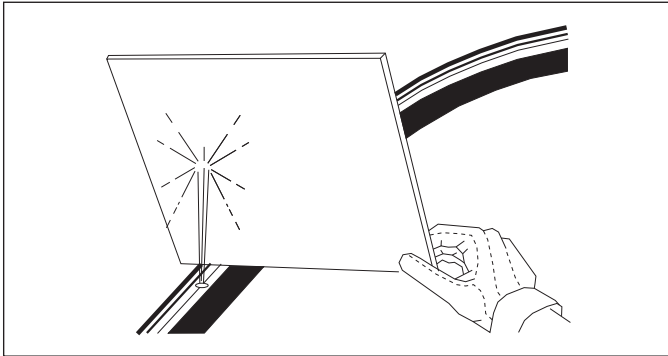

Figure 3-1: Hydraulic Leak Detection

The Pulvi-Mulcher is equipped with a Hydraulic Lift System to raise and lower the unit in the field.

1. The hydraulic system is not factory filled with oil and should be purged of air before transporting and field operations. Carefully hitch the Pulvi-Mulcher to the tractor and connect the hydraulic lift hoses.
2. Check to make sure the tractor hydraulic reservoir is full of the manufacturer's recommended oil.
3. Slowly raise the machine until all lift cylinders are fully extended. Rephasing Series Lift Cylinders rephase on extension. Engage Lift Circuit and keep engaged 30 seconds after Wing Lift Cylinders are fully extended. Lower and raise the unit to verify that all cylinders are working simultaneously throughout the stroke. Fully extend the lift cylinders and continue to hold the lever until all cylinder rod movement stops. Raise/Lower machine 5 times to purge air from the system.
4. Do not loosen any hoses or fittings. Recheck tractor reservoir to make sure it is within operating limits.

The lift circuit uses a counter balance valve to allow pressure between it and tractor tip's to be relieved, but holds machine in raised position.

5. To relieve pressure put circuit in float and machine should remain raised. Be sure to use transport locks. **See Figures 3-6 and 3-9.**

The Lift Circuit with machine raised, requires approximately 4.1 gallons of hydraulic oil and with machine lowered, requires 3.7 gallons of hydraulic oil.

Hydraulic Fold System

Description of System

The Pulvi-Mulcher is equipped with a 2-Stage Hydraulic Fold System to raise and lower the wing frames for narrow transport and supply a constant reduced pressure to the Wing Cylinders for wing down pressure.

The Fold Circuit utilizes a pressure Reducing/Relieving Valve that can supply the base end of the Fold Cylinders with either full tractor hydraulic pressure or a reduced hydraulic pressure. The 2 stages are controlled by a limit valve actuated by the Transport Rockshaft. With the machine raised, the limit valve blocks the "Tank" port from the Reducing/Relieving Valve. With "Tank" port blocked the supply oil to the base end of the Fold Cylinders will be supplied at full tractor pressure. When the machine is lowered the Limit Valve allows flow from the "Tank" port of the Reducing/Relieving Valve to return to the tractor. With "Tank" oil flow allowed, the oil supplied to the base ends of the Wing Fold Cylinders is at reduced pressure. Reduced pressure is adjustable at the Reducing/Relieving Valve and indicated on the Manifold Pressure Gauge. The low pressure setting is sensitive to both flow and back pressure.

Adjusting Low Pressure Setting

Unfold and lower machine. Reduce tractor SCV flow to 30% on the wing circuit. The low pressure is adjustable from 200 to 1000psi. Back pressure is additive to the pressure setting. Pressure setting is adjusted at the Pressure Reducing/Relieving Valve. With Tractor SCV engaged (unfold/down pressure), pressure can be increased by turning the adjustment screw in, or reduced by turning the adjustment screw out. **See Figure 2-21.** Loosen the Jam Nut before making adjustments, re-tighten after making adjustments. Recommended initial pressure setting is 500psi. In field conditions or machine attachments may require additional adjustments.

Folding/Unfolding Operation

To unfold the Pulvi-Mulcher for field use, park on a level area large enough to accommodate the unit when it is fully unfolded. The tractor movement should be stopped.

NOTE

Machine can only be unfolded with machine raised. Automatic Transport Locks engage with Fold Circuit upon folding.

Activate Wing Circuit to unfold wings. The Right Wing will unfold first, then the Left Wing unfolds. Continue to activate unfold so Transport Locks disengage from the Drawbar Leveler and the Center Frame Lift. Activate Lift Circuit to raise the Lift for the Leveler Lock to disengage and to rephase the Lift Cylinders on the Wings. Reduce Wing Fold Circuit flow to 30%.

OPERATION

Lower machine. Engage Wing Fold Circuit to constant flow for Wing Down Pressure (Unfold).

To Fold Machine: All circuits in neutral. Activate Lift Circuit until all Cylinder movement stops and Wing Lift Cylinders are rephased. Engage Wing Circuit to fold. The Left Wing will fold first, Right Wing second. The Wing Wheels will retract on fold to allow clearance for the stack fold. Transport Locks will engage on fold for the Drawbar and Center Frame Lift.

The Fold Circuit requires approximately 13 gallons of hydraulic oil with wings folded and 17 gallons of hydraulic oil with wings unfolded.

Hydraulic Tooth Control

The Pulvi-Mulcher is designed with Hydraulic Tooth Control. The cylinders in conjunction with the Shank Depth Control are used to control shank position. Each Tooth Control Cylinder has an Adjustable Anchor Bolt.

1. To set the Anchor Bolt unfold Pulvi-Mulcher, machine raised, with all Tooth Control Cylinders fully extended. Shanks should be set with Tooth Tubes parallel to the Frame. **See Figure 3-4.**
2. If Tooth Tubes are not parallel to the Frame, check measurement from the Center Frame Tube or Wing Frame Tube to the Cylinder Pin. **See Figures 3-2 and 3-3.** Note the dimensions shown are a starting point.
3. Adjust the Cylinder Anchor Adjustment Nuts until the Tooth Tube is parallel to the frame. Be sure both Center Frame Cylinders Anchors are set the same to ensure left side is synced with right side.

Circuit utilizes Rephasing Cylinders that rephase in the retract position. System can be air purged or rephased by retracting cylinders or raising shanks and continue to flow oil for an extended period of time.

The Tooth Control Circuit with shanks raised requires approximately 2.3 gallons of hydraulic oil, and with shanks lowered requires 2.6 gallons of hydraulic oil.

Shank Depth Control Adjustment

1. A more precise adjustment of the Shanks can be made using the Shank Depth Control. The "F" setting refers to the maximum operating depth. **See Table 3-2.**

Table 3-2: Shank Depth Control

Shank Depth Control	
Letter	Shank Depth
F	5"
E	4-1/2"
D	3-1/2"
C	2-1/2"
B	1"
A	N/A

If making adjustment all Tooth Tube Bearing should be assembled in the same position. **See Figure 3-4.**

2. Adjust the Shank Depth by turning the Depth Stop Handle until the desired letter that matches the required shank depth is centered on the depth Stop Indicator. **See Figure 3-4.**

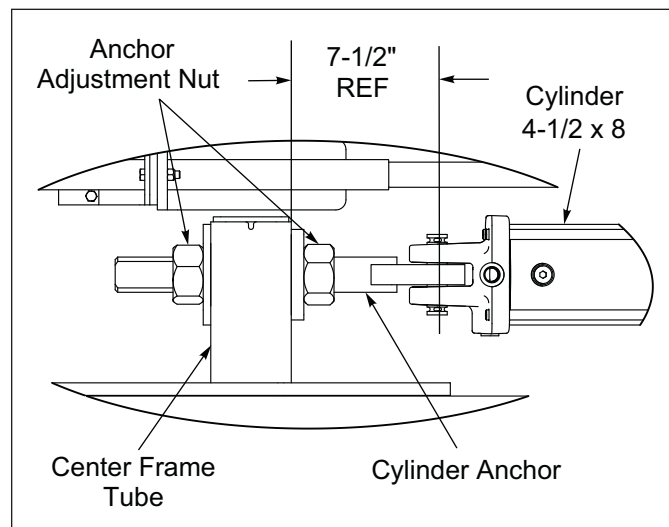

Figure 3-2: Center Frame Hyd Cyl Spacing

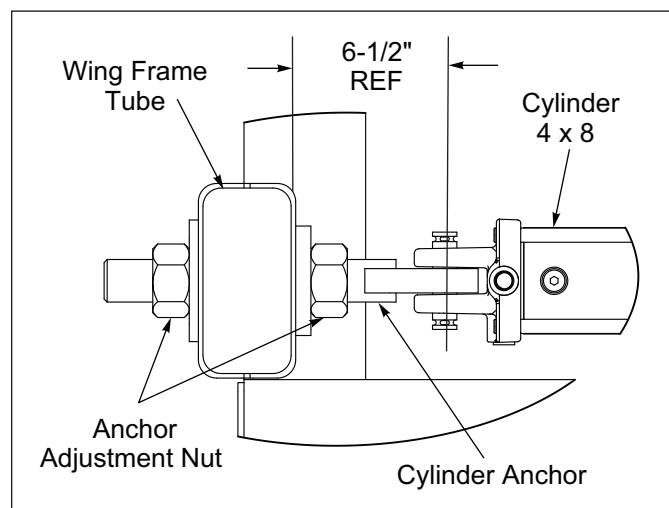

Figure 3-3: Wing Frame Hyd Cyl Spacing

NOTE

Ensure Tooth Tubes are parallel to the frame prior to making any adjustments.

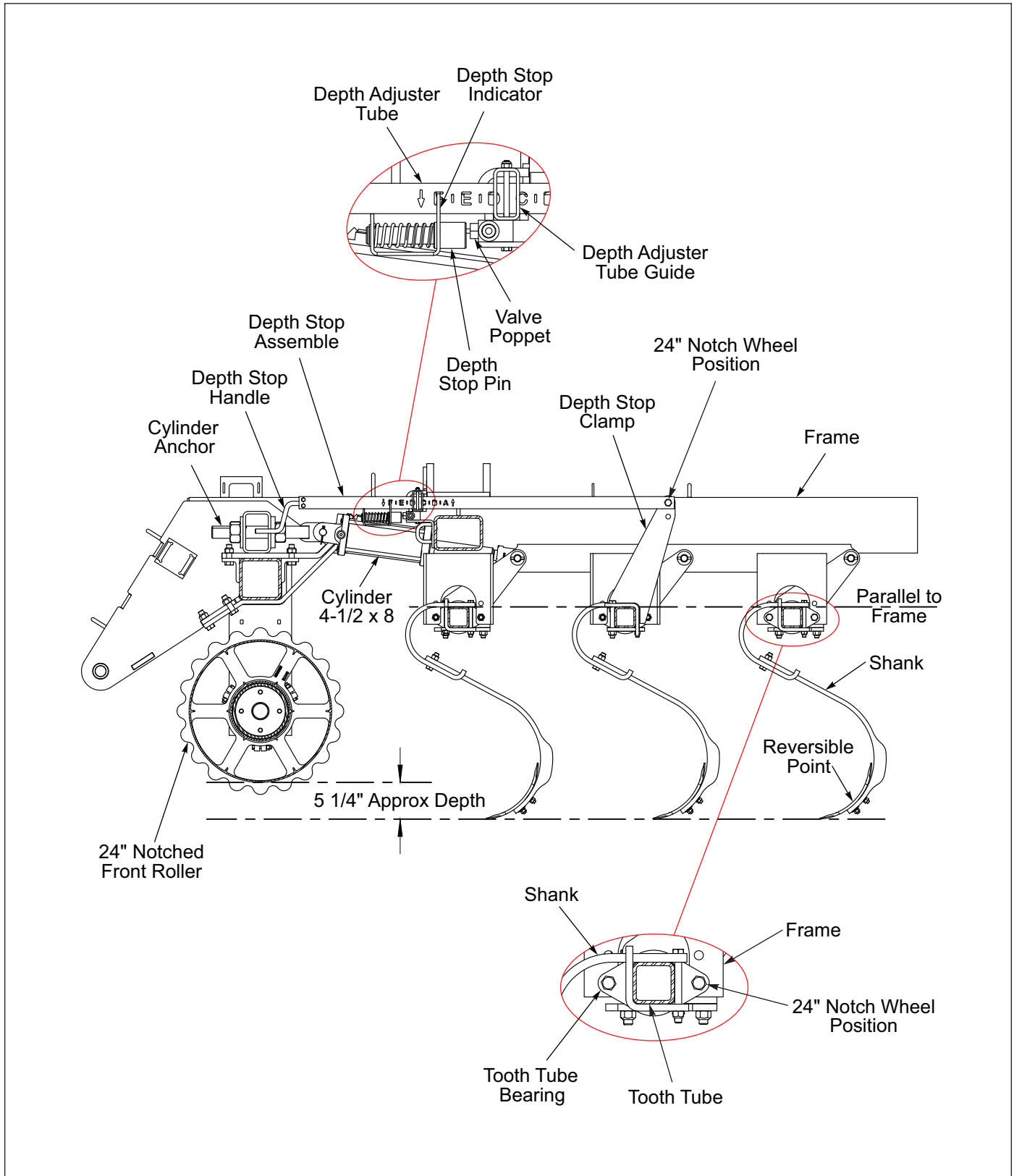

Figure 3-4: Single Point Depth Control

General Operation

1. The minimum horsepower requirements are typically 10-14 horsepower per foot of width. This will vary widely due to speed, depth, moisture, residue and types of soils. Local dealers can help in making recommendations for your areas.
2. Operating speed is typically 5-8 mph. Excessive speed can cause rapid sweep/point wear. Reduce speed in rocky conditions to prevent wheel breakage.
3. Front and Rear Rollers are used to gauge the depth of the shanks. **See Figure 3-4.**
4. Do not turn with the shanks in the ground, this can put excessive side load on the shanks. Raise the shanks using hydraulic tooth control when making turns to prevent bent or broken shanks.
5. Turn off active Wing Down Pressure, put Wing Fold Circuit in float when turning around.



CAUTION

Failure to remove both Locks will cause damage to the Rockshaft.

Operation of Rockshaft Transport Lock

Be sure **both** Rockshaft Transport Locks are either locked or unlocked.

Manual Transport Lock Models

Road to Field

Raise machine fully.

1. Remove Clevis Pins and Hair Pins from Rockshaft Transport Lock U-channel.
2. Actuate the Levers at the rear of the machine to raise the Transport Locks to Field Positions. **See Figure 3-5.**
3. Slide the Levers Into the Field Position Slot in the Lever Brackets.
4. Install the Clevis Pins and Hair Pins into the Lever Brackets to lock the Levers in Field Position.
5. Remove Hitch Leveler Transport Lock, Bent Pin and Hair Pin from Hitch Leveler Cylinder and store it on Hitch Leveler Mast Tab. Install Bent Pin and Hairpin. **See Figure 3-6.**

Field to Road

Raise machine fully.

1. Remove Clevis Pins and Hair Pins from Lever Brackets at the rear of the machine.
2. Actuate the Levers by sliding the Lever in the Lever Bracket to the Transport Lock Position. The Transport Lock should be over the Rockshaft Cylinder Rod. **See Figure 3-5.**
3. Install the Clevis Pins and Hair Pins in the U-Channels on the Rockshaft Cylinders to prevent any unexpected unlocking.
4. Remove Hitch Leveler Transport Lock, Bent Pin and Hair Pin from Hitch Leveler Mast Tab and place Transport Lock over the Hitch Leveler Cylinder Rod. Install Bent Pin and Hairpin. **See Figure 3-6.**

Hydraulic/Automatic Transport Lock Models

Automatic Transport Locks engage the Center Frame Lift and Drawbar Leveler with Fold Circuit. **See "Folding/Unfolding Operation" on Page 3-3.**

Manual Transport Lock Models

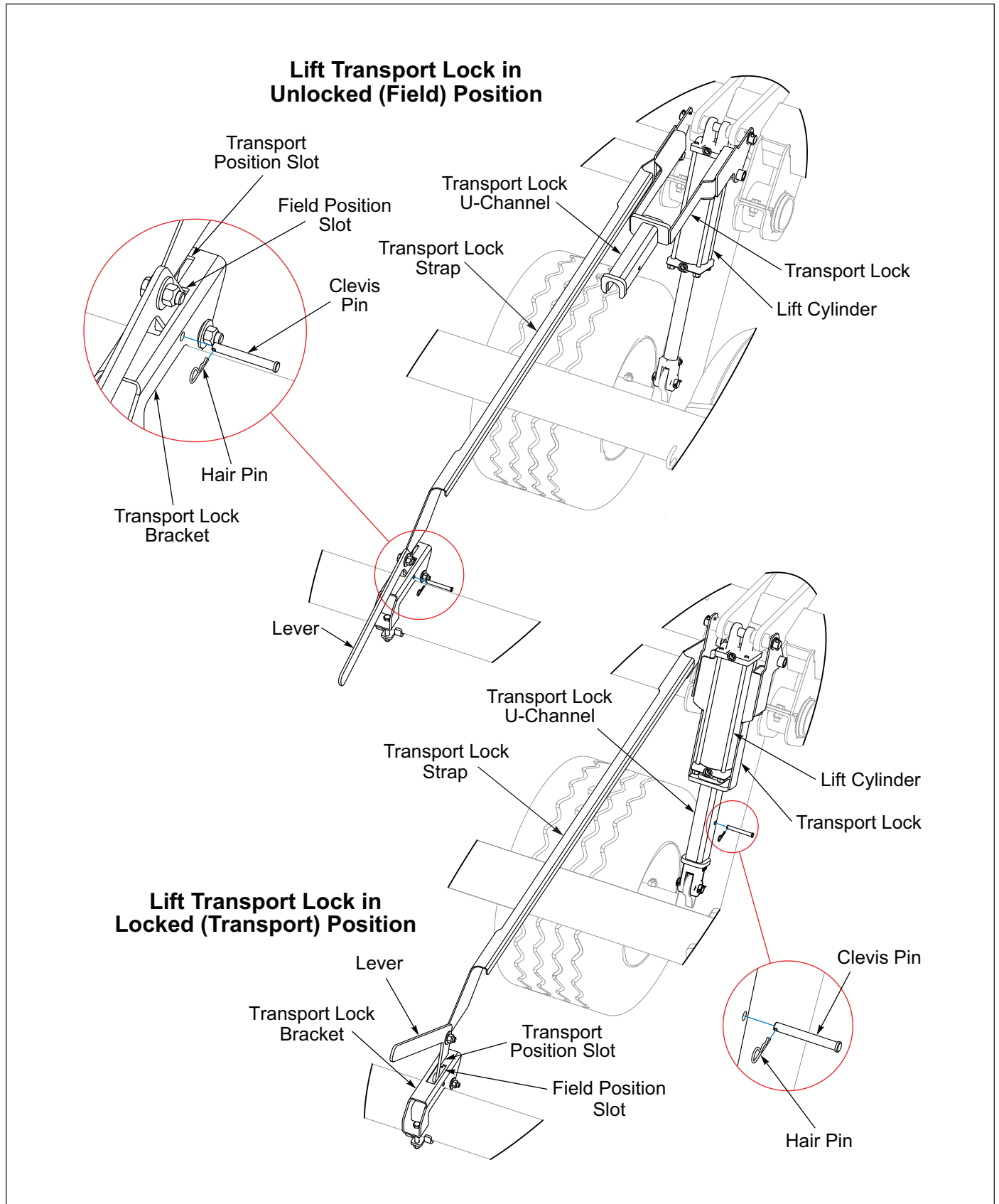
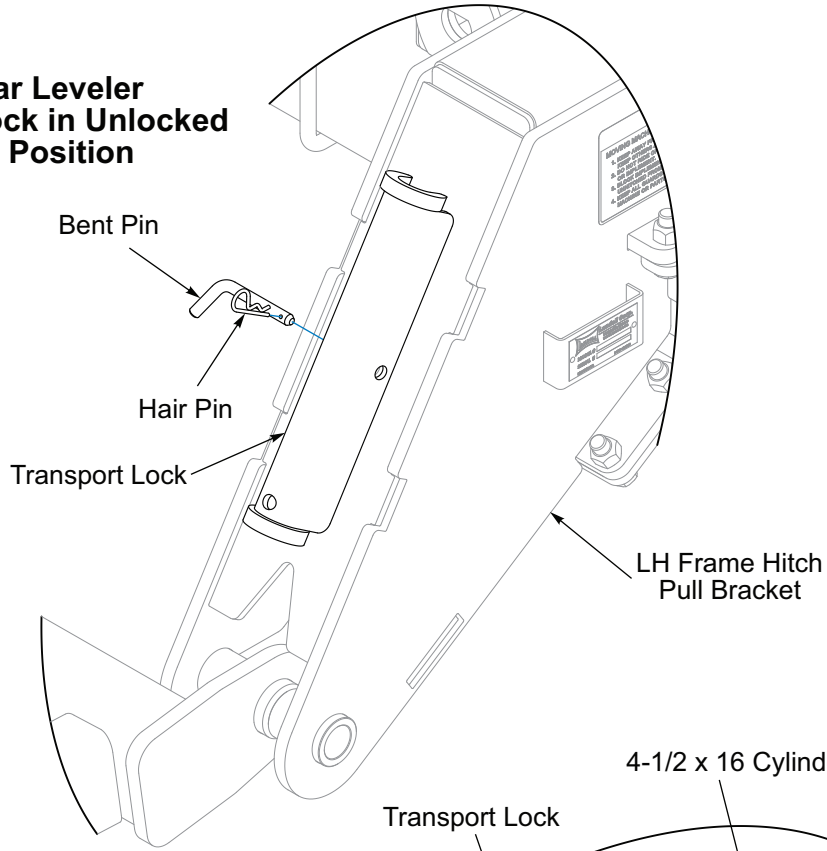

Figure 3-5: Rockshaft Transport Lock Position (Manual Locks)

**Drawbar Leveler
Transport Lock in Unlocked
(Field) Position**



**Drawbar Leveler
Transport Lock in Locked
(Transport) Position**

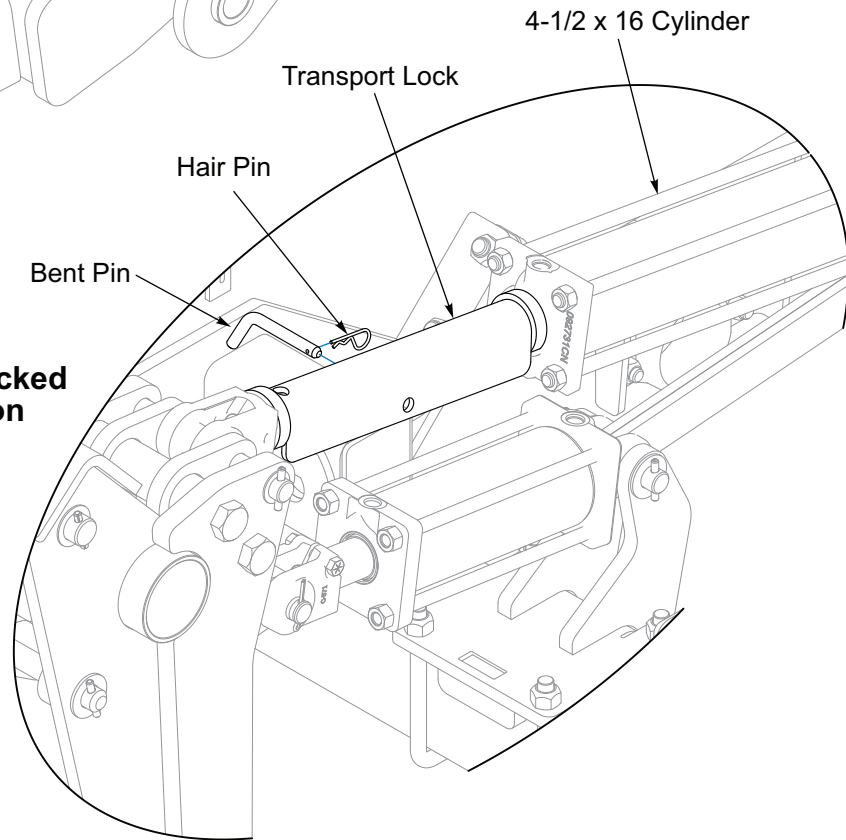
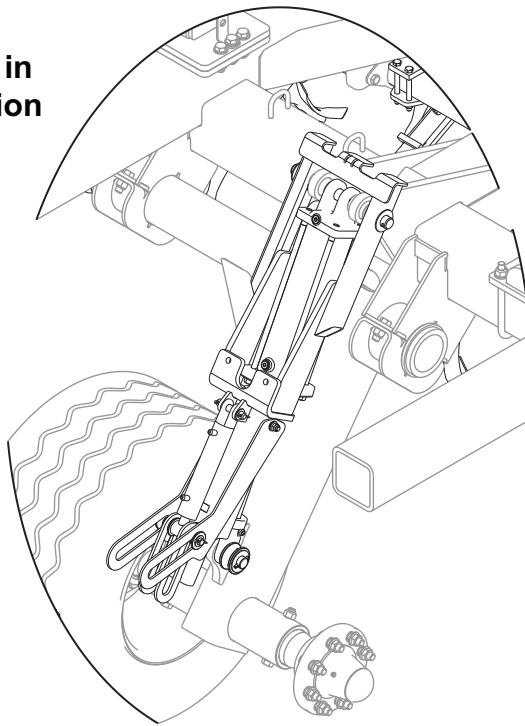

Figure 3-6: Drawbar Leveler Lock Positions (Manual Locks)

Hydraulic/Automatic Transport Locks

**Lift Transport Lock in
Unlock (Field) Position**



**Lift Transport Lock in
Locked (Transport) Position**

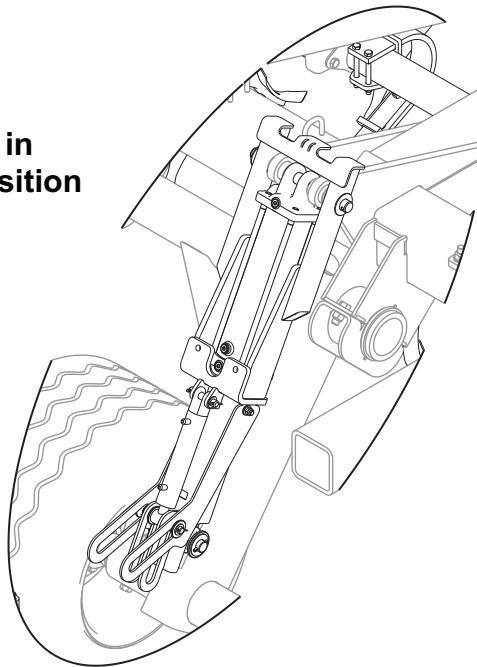
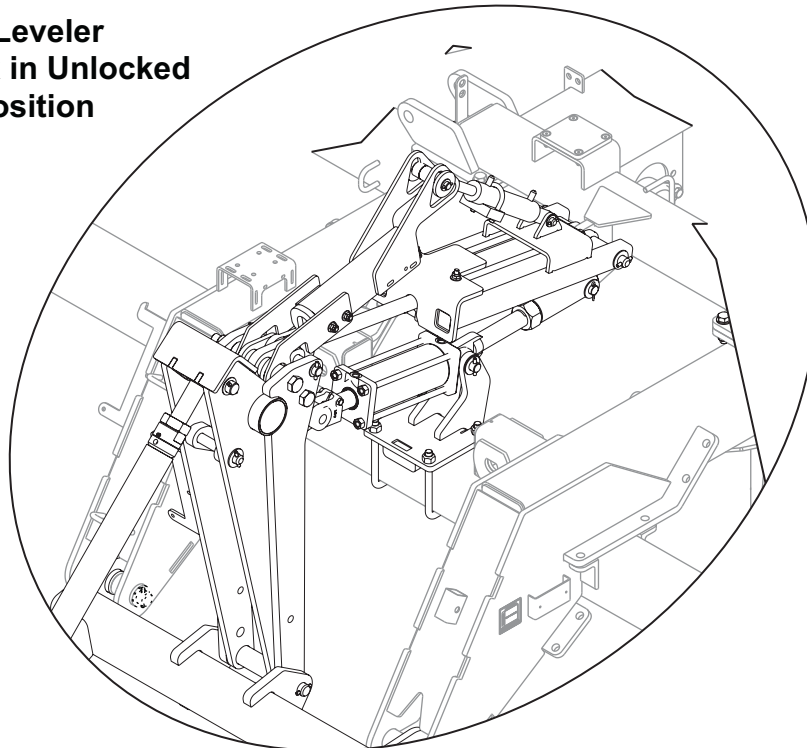

Figure 3-7: Rockshaft Transport Lock Position (Hydraulic/Automatic Locks)

**Drawbar Leveler
Transport Lock in Unlocked
(Field) Position**



**Drawbar Leveler
Transport Lock in Locked
(Transport) Position**

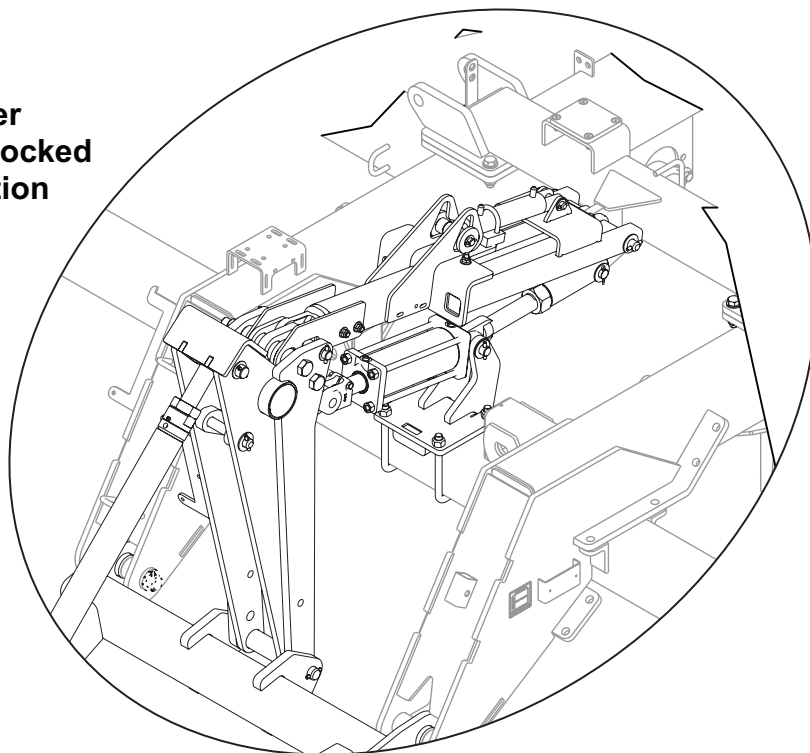

Figure 3-8: Drawbar Leveler Lock Position (Hydraulic/Automatic Locks)

Drawbar Turnbuckle Adjustment

The Pulvi-Mulcher drawbar is designed to float in Field Position and lock into a set position in transport. Depending on tractor hitch height, the Turnbuckle may need to be adjusted to level machine front to rear in transport. Use the open end wrenches located on the Hitch Leveler. See **Figure 3-9**. Machine may need to be lowered to make adjustment. Remove all transport locks before lowering and ensure shanks are raised. See **Figures 3-5 and 3-6**.

Be sure to tighten Jam Nut after any adjustment is made.

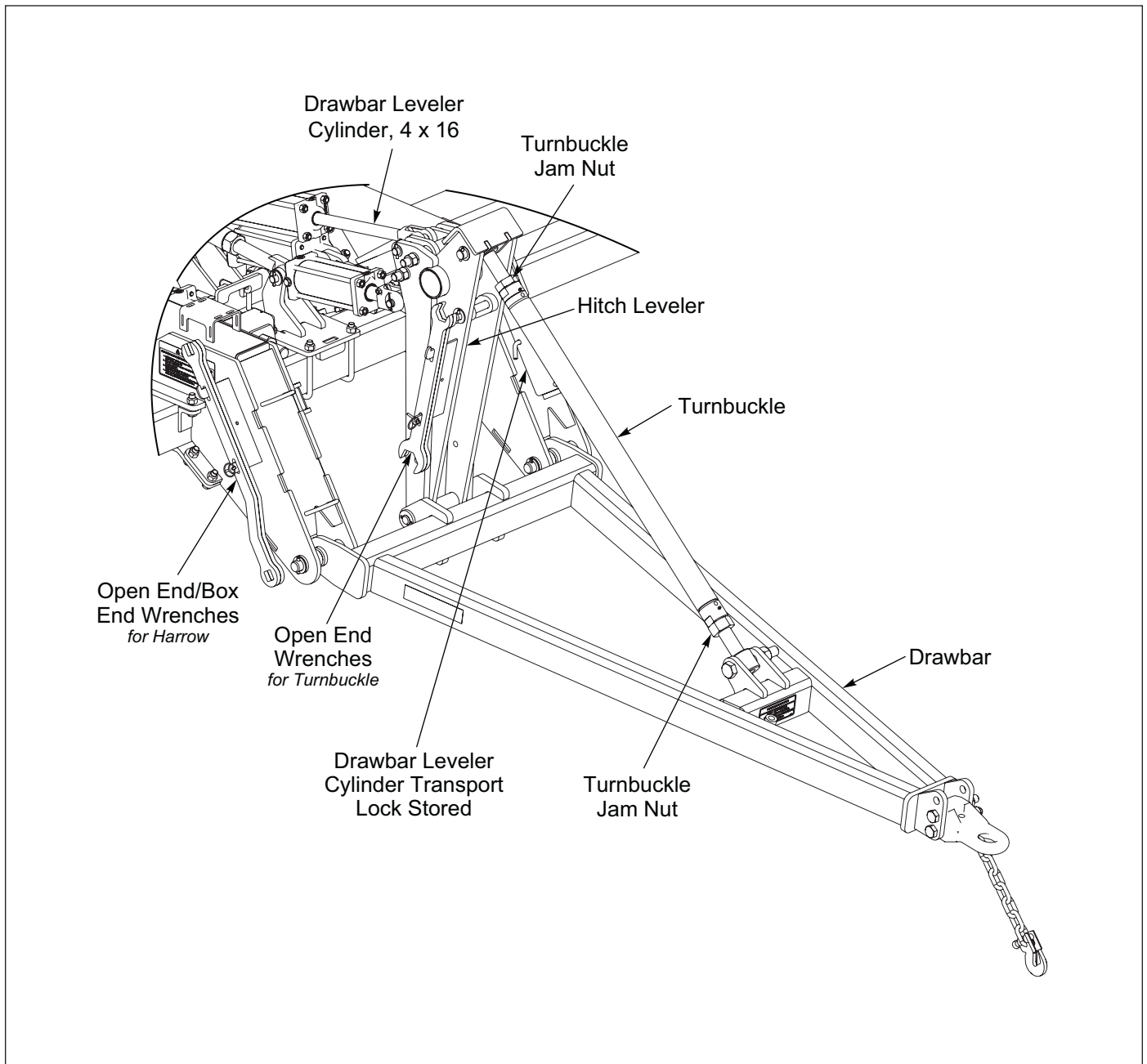

Figure 3-9: Drawbar Turnbuckle Adjustment

OPERATION

Coil Tine Harrow

The Pulvi-Mulcher is equipped with a Coil Tine Harrow to remove the ridges caused by the shanks and tire tracks before the rear roller compacts the soil. The double coils are individually mounted for flexibility and backup protection. In general the Coil Tine Harrow should run level from front to rear. The Tines depth should be adjusted so the tips are approximately 2" into the soil at the desired Tine angle.

NOTE

Tines will hang straight down when implement is raised.

Coil Tine Angle Adjustment

The Coil Tine angle may be adjusted for a steeper more aggressive tooth angle or for a flatter tine angle.

Use a steeper tine angle for clean or minimal residue conditions. Use a flatter tine angle to allow for heavier residue to clear.

1. Adjust the Harrow Coil Tine pitch at the rear of the implement, by removing the Harrow Adjustment Spring Pins from the Angle Adjustment Tubes and rotating the tube to the desired angle. **See Figure 3-10.**
2. Align the Angle Adjustment Tube Hole with the appropriate Gang Bar Plate Hole and insert the Harrow Adjustment Spring Pins.

Coil Tine Harrow Depth Adjustment

1. Adjust the Harrow Depth with the open end/box end wrench located on the right side of the frame by the Drawbar. **See Figure 3-10.**
2. Place the wrench on the 1-1/4" square tube and remove the 1" x 7-5/16" Pins and Hair Pins from both ends. Use the wrench to raise or lower the Harrow to the desired depth and re-insert Pins and Hair Pins.

All three Harrows should be adjusted to the same depth and pitch.

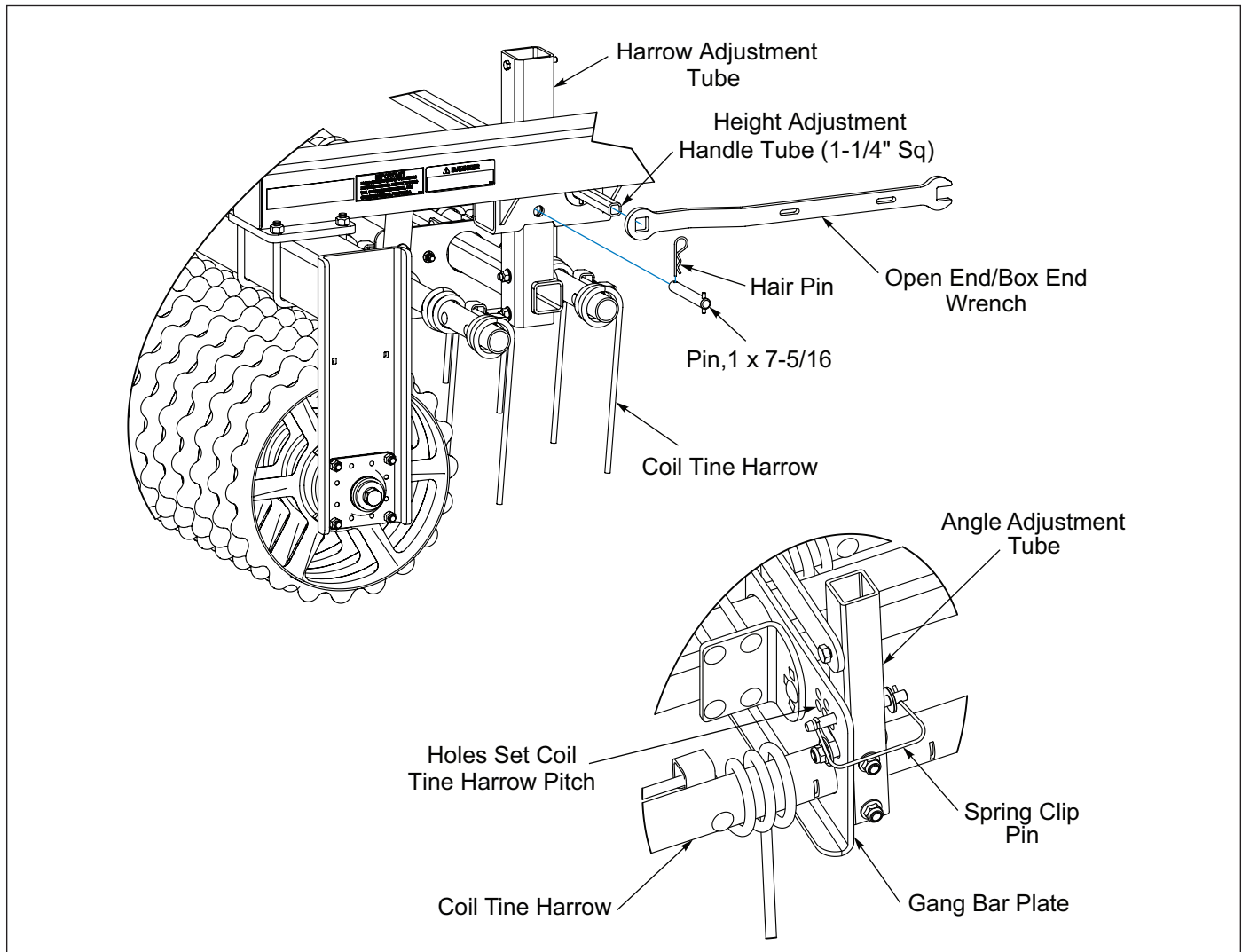

Figure 3-10: Coil Tine Harrow Adjustment

Land Leveler/V-Leveler - Optional

The purpose of the Pulvi-Mulcher Land Leveler and V-Leveler is to help fill in tractor wheel tracks in soft soil. If soil pushes ahead of the bar, it is set too low. Striking large rocks will damage the leveler bar and possibly other parts on the machine. Adjust the Leveler to the highest position that does the required job. A good starting point is 3 to 4 inches above the ground.

V-Leveler Height Adjustment

To raise or lower the Wing Leveler Bars, remove the 1/2-13 x 3 Bolts. To raise or lower the Center Section, remove the 1 x 8 Pin and two 1 x 12-3/4 Pins on the Drawbar. See Figure 3-11.

Land Leveler Height Adjustment

To raise or lower the Center and Wing Leveler Bars, remove the 1/2-13 x 3 Bolts.

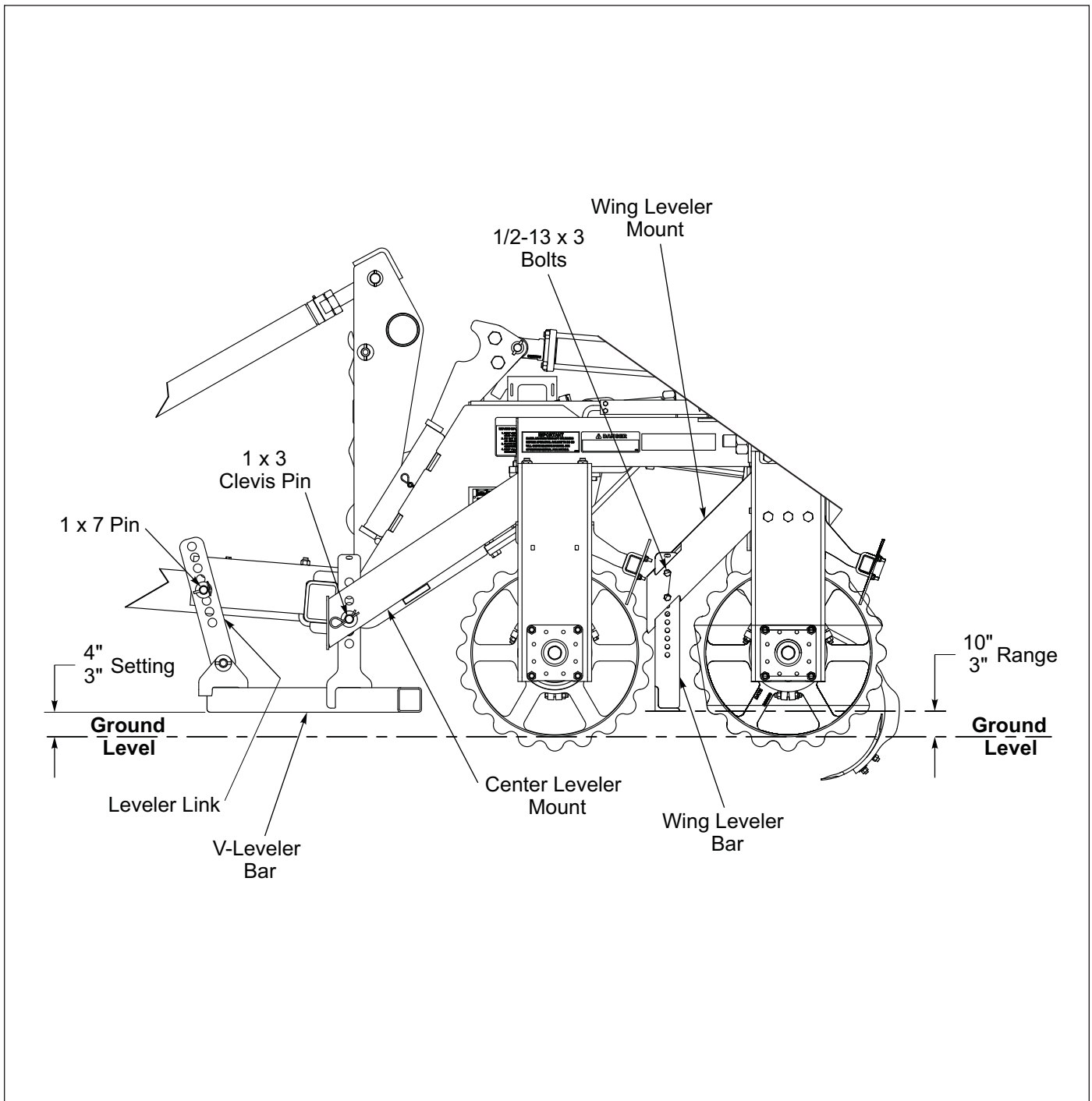

Figure 3-11: V-Leveler Adjustment

Scraper Adjustment

The Pulvi-Mulcher will have Rear Scrapers as standard equipment.

1. Push 24" Notched Wheels against welded stop, add spacer if needed. **See Figures 4-5 and 4-6.**
2. Adjust scrapers to 1/4" gap between scraper and wheel.

3. To adjust scrapers; lower machine on level surface.

NOTE

Scrapers are optional on notched front rollers. Adjustment procedure is the same for the front.

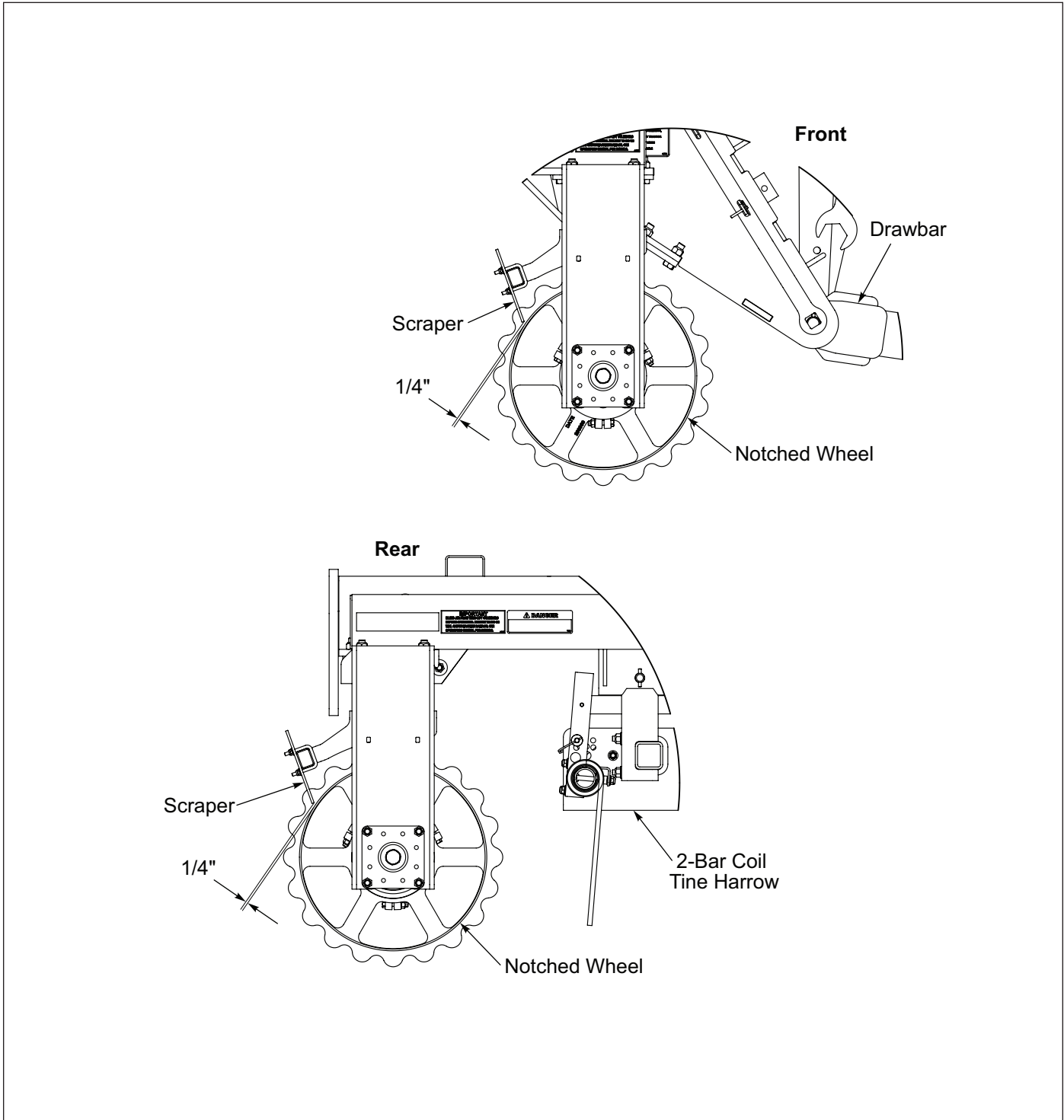

Figure 3-12: Scraper Adjustment

Transport

1. Check and follow all federal, state, and local requirements before transporting the Pulvi-Mulcher.
2. The Pulvi-Mulcher should be transported only by tractor required for field operation. The implement weight should not exceed more than 1.5 times the tractor weight. Maximum transport speed for the Pulvi-Mulcher is 20 mph for the implement and is designated on the speed identification symbol located on the front of the implement. **See Figure 3-13.**

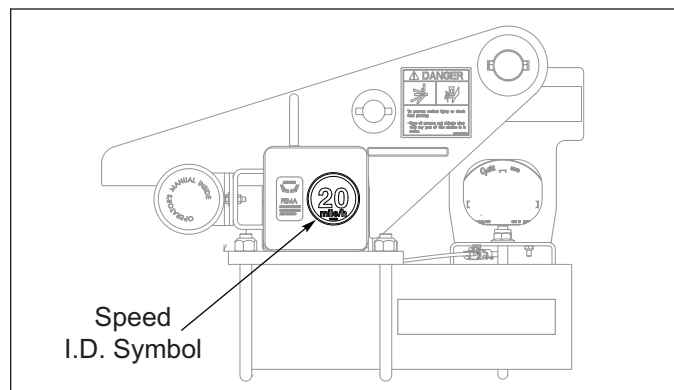

Figure 3-13: Speed Identification Symbol

CAUTION

Excessive speed may result in loss of control of the tractor and implement, reduced braking ability, or failure of the implement tire or structure. Do not exceed the implement maximum specified ground speed regardless of the capability of the maximum tractor speed.

3. When towing equipment in combination, the maximum equipment ground speed shall be limited to the lowest specified ground speed of any of the towed implements.

Maximum transport speed shall be the lesser of travel speed specified in the operator's manual, speed identification symbol, information sign of towed equipment, or limit of road conditions.

4. Slow down when driving on rough roads. Reduce speed when turning, or on curves and slopes to avoid tipping. Equipment altered other than the place of manufacture may reduce the maximum transport speed. Additional weight, added tanks, harrowing attachments, etc. may reduce implement load carrying capabilities.
5. A Safety Chain is provided with the implement to insure safe transport. **See Figure 1-2.**
 - The Safety Chain should have a tensile strength equal to or greater than the gross weight of the implement. The chain is attached to the lower hitch clevis hole with two flat washers between the clamp plates to assure a tight connection. Always use a 1" diameter Grade 8 bolt for this connection.
 - Attach the Safety Chain to the tractor drawbar. **See Figure 1-2.** Provide only enough slack in the chain for turning. Do not use an Intermediate Chain Support as the attaching point for the chain on the tractor. Do not pull the implement by the Safety Chain.
 - Regularly inspect the Safety Chain for worn, stretched, or broken links and ends. Replace the Safety Chain if it is damaged or deformed in any way.

6. Before transporting:
 - Check that tires are of proper size, load rating, and inflated to manufacture specifications before transporting. Check wheel lug bolts to ensure tightness.
 - Know the transport heights and widths of the unit before transporting. Use caution when transporting near bridges and power lines.

DANGER

Stay away from power lines when transporting, extending implement. Electrocutation can occur without direct contact.

- Raise the machine to full transport height.
- Install Transport Locks on lift systems. Do not depend solely on implement hydraulics for transport. **See Figures 3-5 and 3-6.**

WARNING

Failure to use Transport Lock Pins during transport may result in permanent equipment damage, serious injury or death.

- Transport during daylight hours when ever possible. Always use flashing warning lights, except where such use is prohibited by law. Make sure lights, reflectors and SMV emblem are clearly visible and operating. remove any obstructions such as dirt, mud, stalks or residue that restricts view before transporting.

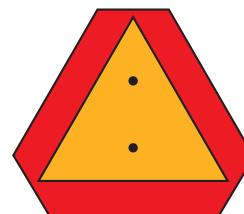

Figure 3-14: SMV Sign

General Torque Specifications

(rev. 4/97)

This chart provides tightening torques for general purpose applications when special torques are not specified on process or drawing. Assembly torques apply to plated nuts and capscrews assembled without supplemental lubrication (as received condition). They do not apply if special graphite moly-disulfide or other extreme pressure lubricants are used. When fasteners are dry (solvent cleaned) add 33% to as received condition torque. Bolt head identification marks indicate grade and may vary from manufacturer to manufacturer. Thick nuts must be used on grade 8 capscrews. Use value in [] if using prevailing torque nuts.

TORQUE SPECIFIED IN FOOT POUNDS

UNC SIZE	SAE Grade 2	SAE Grade 5	SAE Grade 8	UNC SIZE	SAE Grade 2	SAE Grade 5	SAE Grade 8
1/4-20	4 [5]	6 [7]	9 [11]	1/4-28	5 [6]	7 [9]	10 [12]
5/16-18	8 [10]	13 [13]	18 [22]	5/16-24	9 [11]	14 [17]	20 [25]
3/8-16	15 [19]	23 [29]	35 [42]	3/8-24	17 [21]	25 [31]	35 [44]
7/16-14	24 [30]	35 [43]	55 [62]	7/16-20	27 [34]	40 [50]	60 [75]
1/2-13	35 [43]	55 [62]	80 [100]	1/2-20	40 [50]	65 [81]	90 [112]
9/16-12	55 [62]	80 [100]	110 [137]	9/16-18	60 [75]	90 [112]	130 [162]
5/8-11	75 [94]	110 [137]	170 [212]	5/8-18	85 [106]	130 [162]	180 [225]
3/4-10	130 [162]	200 [250]	280 [350]	3/4-16	150 [188]	220 [275]	320 [400]
7/8-9	125 [156]	320 [400]	460 [575]	7/8-14	140 [175]	360 [450]	500 [625]
1-8	190 [237]	408 [506]	680 [850]	1-14	210 [263]	540 [675]	760 [950]
1-1/8-7	270 [337]	600 [750]	960 [1200]	1-1/8-12	300 [375]	660 [825]	1080 [1350]
1-1/4-7	380 [475]	840 [1050]	1426 [1782]	1-1/4-12	420 [525]	920 [1150]	1500 [1875]
1-3/8-6	490 [612]	1010 [1375]	1780 [2225]	1-3/8-12	560 [700]	1260 [1575]	2010 [2512]
1-1/2-6	650 [812]	1460 [1825]	2360 [2950]	1-1/2-12	730 [912]	1640 [2050]	2660 [3325]

METRIC:

Coarse thread metric class 10.9 fasteners and class 10.0 nuts and through hardened flat washers, phosphate coated, Rockwell "C" 38-45. Use value in [] if using prevailing torque nuts.

Nominal thread diameter (mm)	Newton Meters (Standard Torque)	Foot Pounds (Standard Torque)	Nominal Thread Diameter (mm)	Newton Meters (Standard Torque)	Foot Pounds (Standard Torque)
6	10 [14]	7 [10]	20	385 [450]	290 [335]
7	16 [22]	12 [16]	24	670 [775]	500 [625]
8	23 [32]	17 [24]	27	980 [1105]	730 [825]
10	46 [60]	34 [47]	30	1330 [1470]	990 [1090]
12	80 [125]	60 [75]	33	1790 [1950]	1340 [1450]
14	125 [155]	90 [115]	36	2325 [2515]	1730 [1870]
16	200 [240]	150 [180]	39	3010 [3210]	2240 [2380]
18	275 [330]	205 [245]			

Hydraulic Fitting Torque Specifications

37 degree JIC, ORS, &ORB (REV. 10/97)

This chart provides tightening torques for general purpose applications when special torques are not specified on process or drawing. Assembly torques apply to plated nuts and capscrews assembled without supplemental lubrication (as received condition). They do not apply if special graphite moly-disulfide or other extreme pressure lubricants are used. When fasteners are dry (solvent cleaned) add 33% to as received condition torque. Bolt head identification marks indicate grade and may vary from manufacturer to manufacturer. Thick nuts must be used on grade 8 capscrews. Use value in [] if using prevailing torque nuts.

TORQUE SPECIFIED IN FOOT POUNDS

PARKER® BRAND FITTINGS

Dash Size	37 Deg. JIC	O-ring (ORS)	O-ring boss
-4	11-13	15-17	13-15
-5	14-16	-----	21-23
-6	20-22	34-36	25-29
-8	43-47	58-62	40-44
-10	55-65	100-110	58-62
-12	80-90	134-146	75-85
-16	115-125	202-218	109-121
-20	160-180	248-272	213-237
-24	185-215	303-327	238-262
-32	250-290	-----	310-340

GATES® BRAND FITTINGS

Dash Size	37 Deg. JIC	O-ring (ORS)	O-ring boss
-4	10-11	10-12	14-16
-5	13-15	-----	-----
-6	17-19	18-20	24-26
-8	34-38	32-40	37-44
-10	50-56	46-56	50-60
-12	70-78	65-80	75-83
-14	-----	65-80	-----
-16	94-104	92-105	111-125
-20	124-138	125-140	133-152
-24	156-173	150-180	156-184
-32	219-243	-----	-----

AEROQUIP® BRAND FITTINGS

Dash Size	37 Deg. JIC	O-ring (ORS)	O-ring boss
-4	11-12	10-12	14-16
-5	15-16	-----	16-20
-6	18-20	18-20	24-26
-8	38-42	32-35	50-60
-10	57-62	46-50	75-80
-12	79-87	65-70	125-135
-14	-----	-----	160-180
-16	108-113	92-100	200-220
-20	127-133	125-140	210-280
-24	158-167	150-165	270-360

Fasteners

Before operating your Brillion machine, check all hardware for tightness. Use the Tightening Torque Table as a guide. **See Page 4-1.**

After a few hours of use, check entire machine and tighten any loose nuts or bolts. Daily or periodic checks should be made thereafter.

When replacing bolts, be sure to use fasteners of equal grade.

Tires

Recommended Center Frame Tire Size: 480/45R17

Recommended Wing Tire Size: 320/70R15

Tire Inflation Pressure: 70 PSI.

When Re-Installing the 3/4-16 Flange nuts tighten to 50 foot-pounds using the sequence in **Figure 4-1**. Then tighten to full torque of 220 ft-lbs.

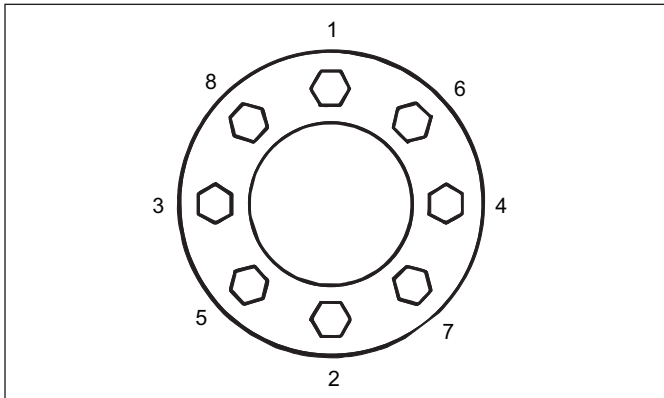

Figure 4-1: Stud Tightening Sequence

Wheel Hub Bearing Maintenance

Wheel bearing maintenance should be performed at the beginning of every season of use. Check the wheel bearings periodically for excessive end play. If needed, adjust or replace them using the following procedure:

1. Place the Frame on blocks or stands sufficient to lift the Tire clear of the ground.
2. Remove the tire.
3. Remove the Hub Cap, Cotter Pin, Slotted Nut and Washer.
4. Remove the Hub. Clean and inspect the Bearings and Hub Cavity. Replace any worn or defective parts.
5. Repack the Bearings using a high-quality Wheel Bearing Grease.
6. Slide the Triple-lip Seal onto the Spindle. Do not install the Seal into the Hub.

NOTE

The Triple-lip Seals should point away from the hub to keep contaminants out and allow grease to pass.

7. Slide the inner bearing cone and hub onto the spindle.
8. Install the Hub, Outer Bearing Cone, Washer and Slotted Nut.
9. Tighten the Slotted Nut while rotating the Hub until there is a slight resistance to wheel rotation. Then, back the Slotted Nut off one notch, until the wheel rotates freely without end play.

10. Slide the Triple Lip Seal to the Hub and install the Seal in the Hub
11. Install a new Cotter Pin and re-install the Hub Cap.

Lubrication Maintenance

The 3631 Pulvi-Mulcher is equipped with Maintenance Free Bearings in the Lifts, Leveler, and Wings Hinges. These areas require no lubrication.

Pulverizer Axle Roller Assembly Bearings are sealed with a Triple Lip Seal and are non-lubricable.

Grease turnbuckle every 50 hrs or yearly to prevent seizure. **See Figure 4-2.**

Grease wheels hubs every 50 hrs. **See Figure 4-2.**

Hydraulic Maintenance

IMPORTANT

Unfold, lower the unit to the ground, and relieve hydraulic pressure before attempting to service any hydraulic component.

1. Check the hydraulic fluid level per tractor owner's manual and after any leakage. Check hydraulic fluid level when the shanks are raised, wings are folded and machine is raised for transport.

NOTE

Note when machine is lowered, wings unfolded and shanks lowered for field operation the machine requires approximately 1-1/2 more gallons of hydraulic fluid.

2. If a cylinder or valve leaks, disassemble the parts to determine the cause of the leak. Any time a cylinder is opened up, or whenever any seal replacement is necessary, it is advisable to clean all parts and replace all seals. Seal kits are available from your Brillion dealer.
3. Check all hydraulic hoses weekly. Look for binding or cracking. Replace all worn or defective parts immediately.
4. Transport locks are provided to hold the implement in a raised position. **See Figures 3-5 and 3-6.** Do not attempt to perform any service work under the implement without first installing the transport locks. Before servicing any hydraulic component, lower the implement to the ground and relieve all system pressure. If a hydraulic component is disconnected, repaired, or replaced, it will be necessary to purge the system of air before operation. **See "Hydraulic Leak Detection" and "Hydraulic Fold System" on page 3-3** on how to purge the hydraulic systems.

Ensure that the hoses and fittings are properly assembled at the Fold/Down Pressure Valve, **See Figures 2-20 and 2-21.**

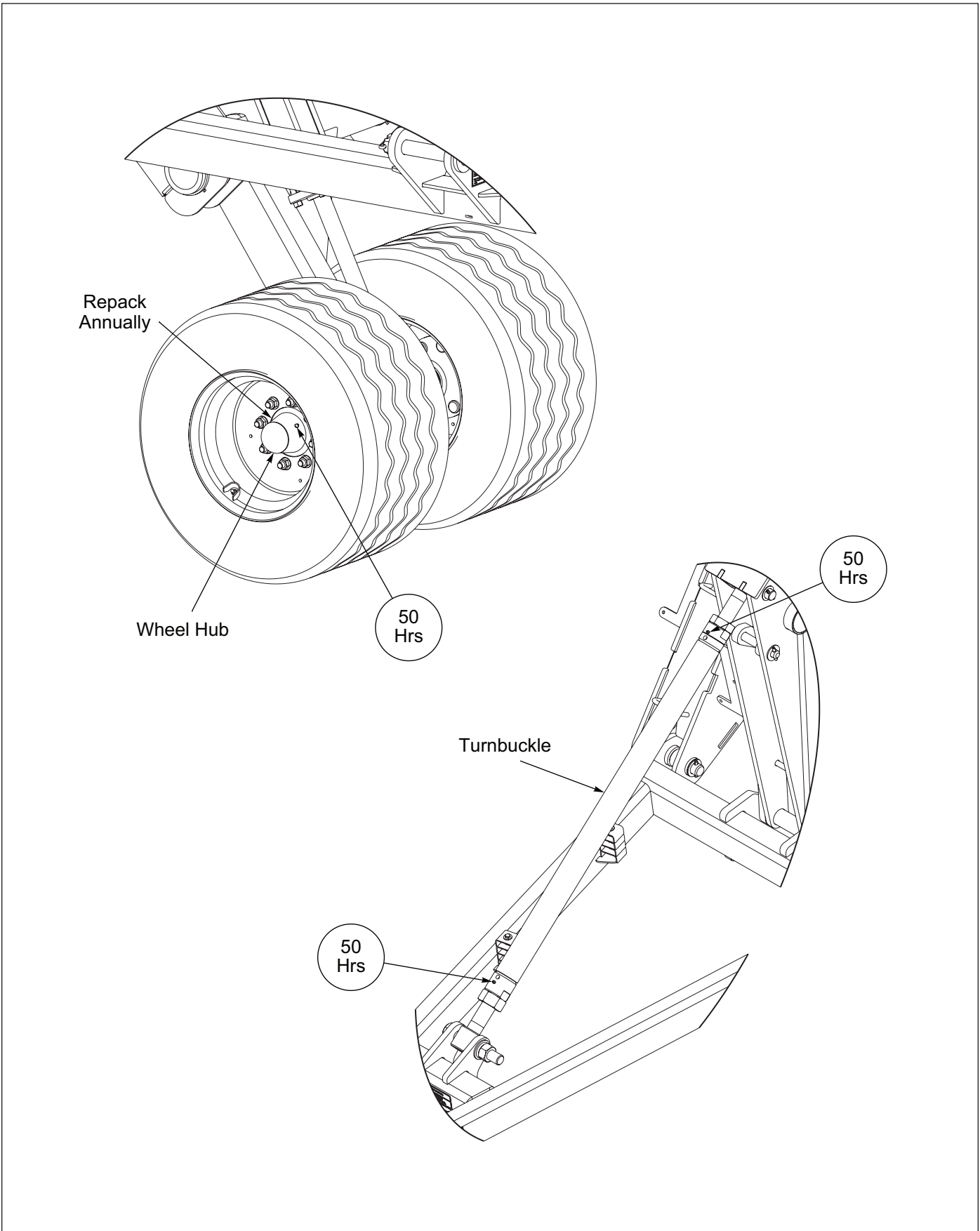

Figure 4-2: Lubrication Points and Intervals

Roller Axle Assembly

After an initial run of 5-10 hours, check the Roller Axle Assemblies to ensure that the wheels are tight to one another. If not, starting at the welded stop end, slide the wheels tight together and adjust the Axle Clamps so that it's against the wheel. **See Figure 4-3** If there is a gap between the Axle Clamp and Wheel Stop, install the appropriate clamp spacers. **See Figures 4-5 and 4-6.**

Clamp Tightening

Tighten the Clamp bolts evenly to achieve equal spacing between clamp section. Torque to 75 ft-lbs. Thereafter check assemblies every 50-100 hours. **See Figure 4-4.**

NOTE

Note when machine is lowered, wings unfolded and shanks lowered for field operation the machine requires approximately 1-1/2 more gallons of hydraulic fluid.

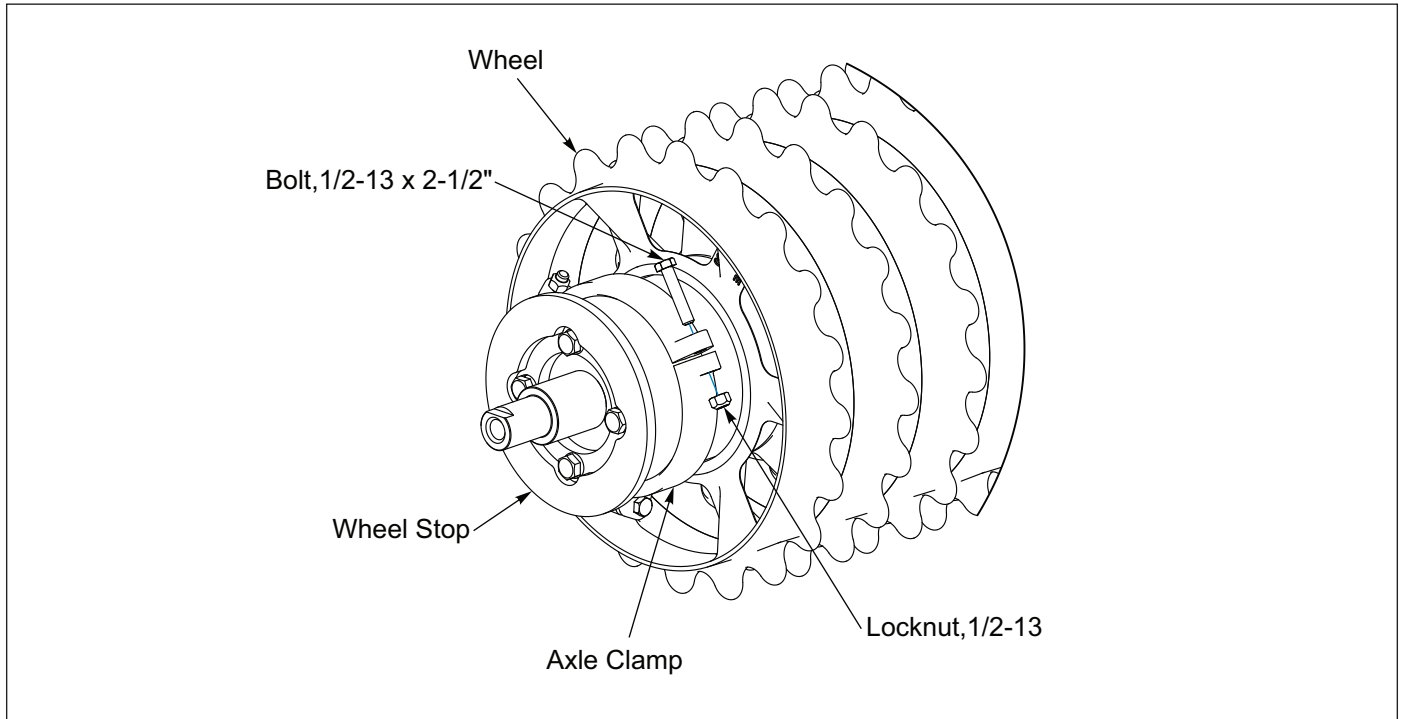

Figure 4-3: Roller Axle Assembly

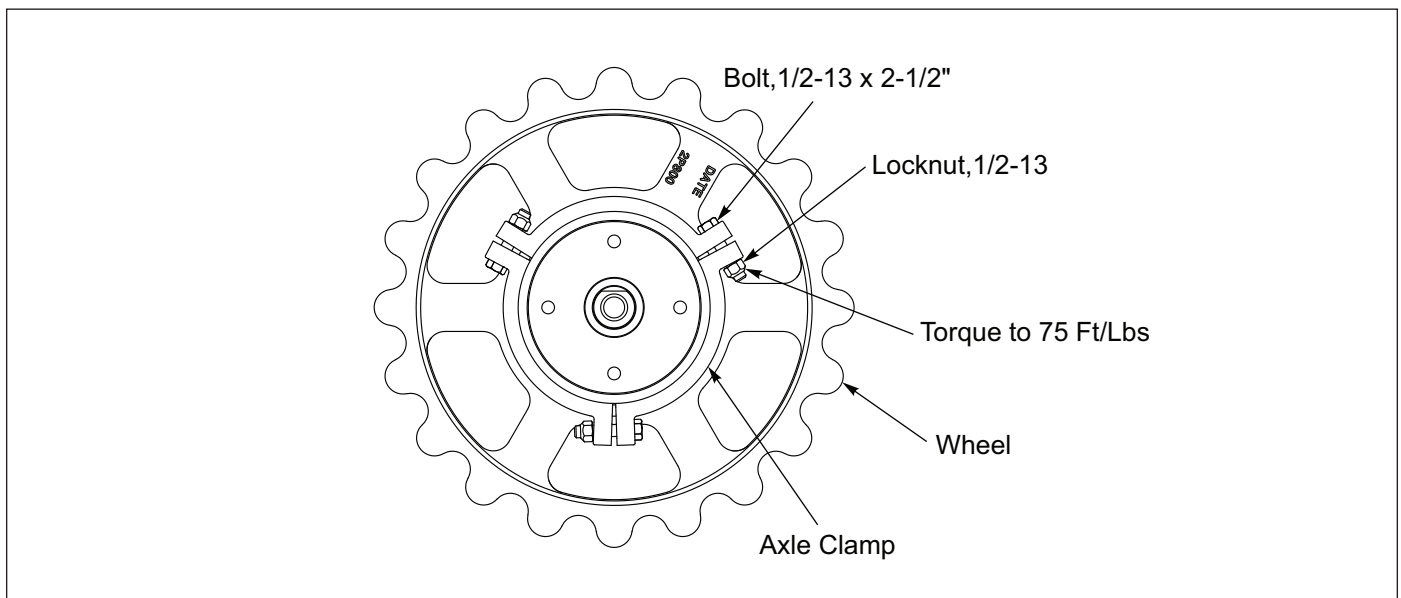

Figure 4-4: Clamp Tightening

Clamp End Spacers - Optional

The Clamp End Spacer Kits are used to eliminate space between the Axle Clamp and the Wheel Stop.

IMPORTANT

Unfold and lower machine prior to performing any steps.

Kit Part Number 201442 - 3/4" Axle Spacer

Kit Part Number 201443 - 1/2" Axle Spacer

Installation is the same for either kit.

1. Place the two Axle Spacers between the Axle Clamp and the Wheel Stop.
2. Insert two 3/8-16 x 1-3/4 Bolts through the Axle Spacers and secure with 3/8-16 Locknuts.
3. Refer to the Torque Table for proper bolt torque values.

NOTE

*The different torque requirement for Bolts with Locknut
See page 4-1.*

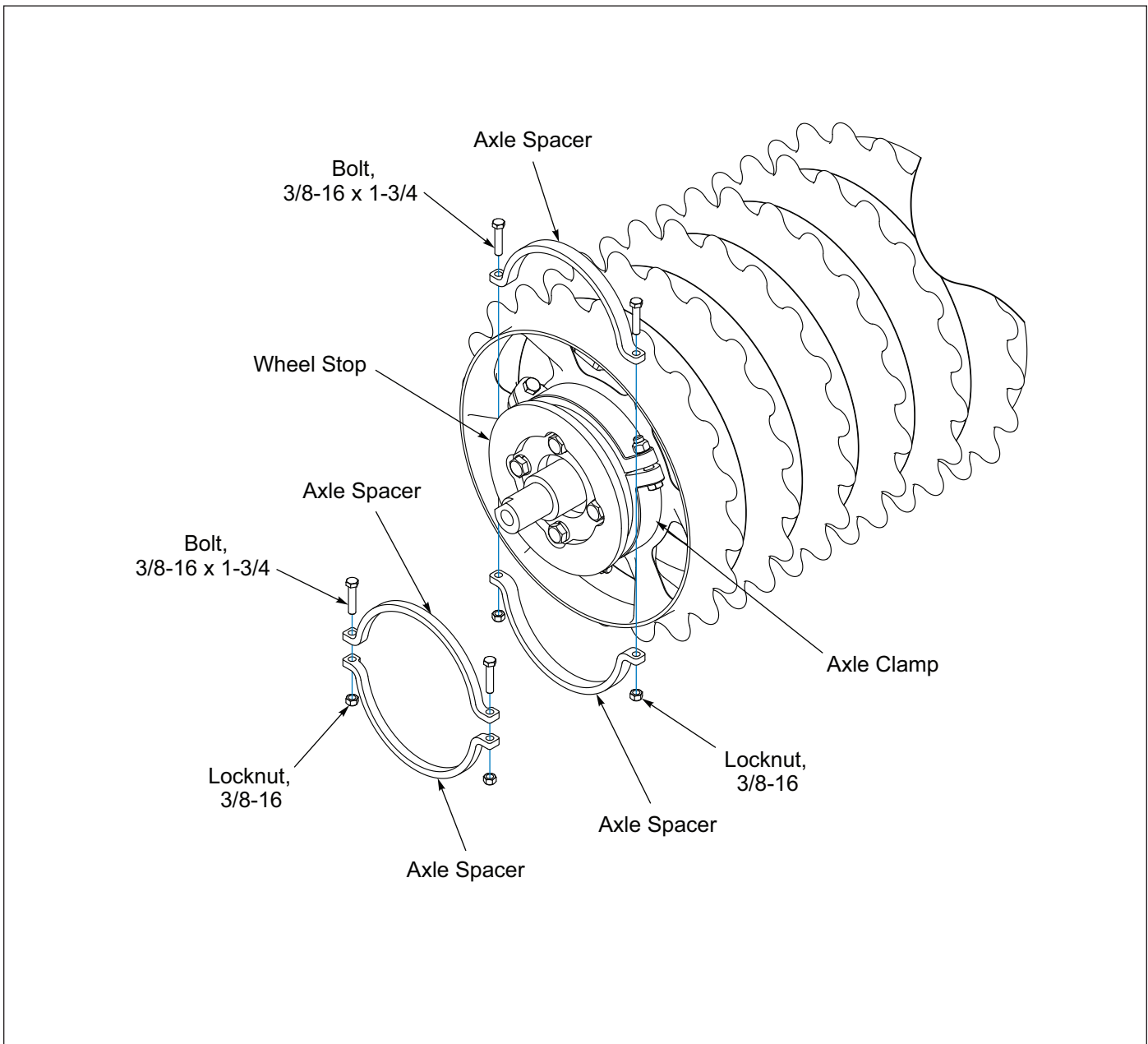

Figure 4-5: Clamp End Spacer Kit 1 of 2 - Optional

Kit Part Number 204831 - 1" Axle Spacer

Kit Part Number 204832 - 1-1/4" Axle Spacer

Kit Part Number 204833 - 1-1/2" Axle Spacer

1. Place the two Axle Spacers between the Axle Clamp and the Wheel Stop.
2. Insert two 3/8-16 x 1 Bolts through the Axle Spacers and secure with 3/8-16 Locknuts.

Refer to the Torque Table for proper bolt torque values.

NOTE

*The different torque requirement to Bolts with Locknuts.
See Page 4-1.*

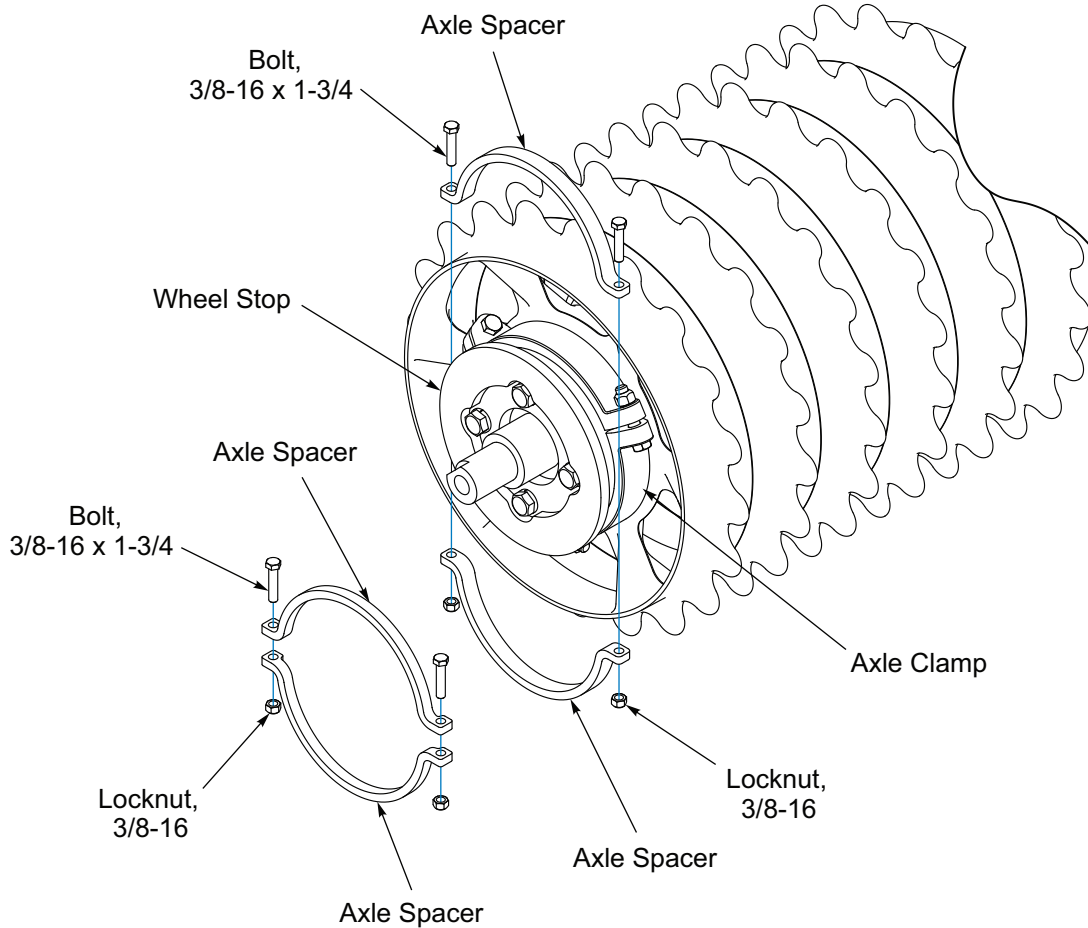

Figure 4-6: Clamp End Spacer Kit 2 of 2 - Optional

LED Warning Lamps

When plugging in the LED 7-Pin Connector:

1. Make sure the tractor has a good clean receptacle, free of dirt and corrosion.
2. Make sure the 7-Pin Connector is inserted ALL the way in. With tighter fitting pins, operator may think the connector is all the way in, but really isn't.
3. Make sure the tractor receptacle cover latches over the keyway on the 7-Pin Connector to hold the connector in place.

If an operator plugs in the 7-Pin Connector, but the lights do not seem to work right, check the above items to make sure there is a good connection with the 7-Pin Connector.

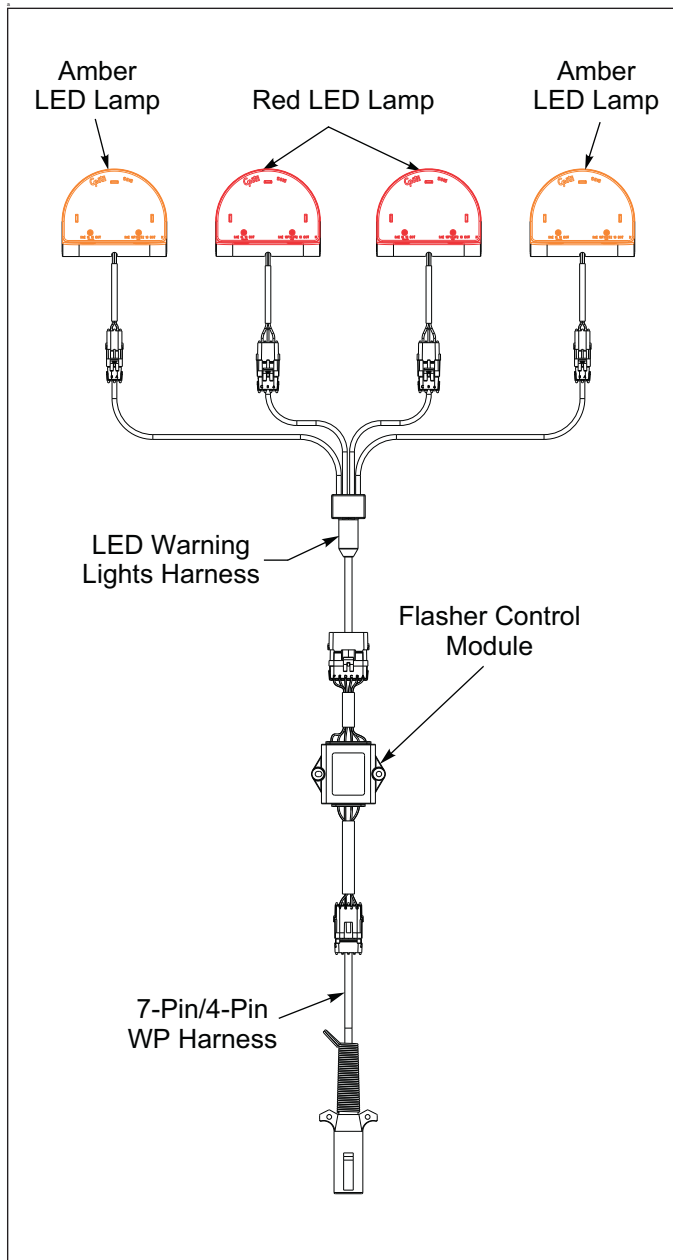

Figure 4-7: LED Warning Lamps

Storage

1. The service life of the Pulvi-Mulcher will be extended by proper off-season storage practices. Prior to storing the unit, complete the following procedures:
 - a. Completely clean the unit
 - b. Inspect the machine for worn or defective parts. Replace as needed.
 - b. Repaint all areas where the original paint is worn off.
 - c. Grease all exposed metal surfaces of shanks and points.
 - d. Apply a light coating of oil or grease to exposed cylinder rods to prevent them from rusting.
 - e. Lubricate each point of the machine as stated in **“Lubrication Points and Intervals” on page 4-4.**
2. Store the unit in a shed or under a tarpaulin to protect it from the weather. The ground tools and tires should rest on boards, or some other object, to keep them out of the soil.
3. If the unit is stored in the folded position, make sure the transport lock pins are installed to prevent settling.
4. Relieve Hydraulic Pressure in hoses after locks are installed.
5. Block wheels before unhitching from tractor

Maintenance Chart

(Subject to change without notice)

	Initial Run-In	20 Hours	50 Hours	100 Hours/Annually	Storage
Fasteners, Wheel Hub Bolts	X			X	
Grease: Turnbuckle			X		
Adjust Scraper if equipped			X		
Grease Wheel Hub			X	X	
Repack Wheel Hub Bearings				X	
Tighten Roller Axle Wheels and Clamps			X	X	
** Clean machine					X
Grease after cleaning					X
Touch-up paint					X

*** Avoid spraying high pressure washer directly at bearing seals and electrical connections.*

Figure 4-8: Maintenance Chart

General Reference and Specifications

	WLB-3631-36
Approximate Weight	32,784 lbs. (14,871 kg)
Working Width	36 ft. (11.0 m)
Transport Width	18 ft. 10 in. (5.7 m)
Transport Height	13 ft. 8 in. (4.2 m)
Overall Length (Transport)	29 ft. (8.8 m)
Road Clearance	15 in. (381 mm)
Type of Pulverizer Wheel - Front	24 in. (609.6 mm) Notched Ductile Iron
Number of Pulverizer Wheels - Front	110
Type of Pulverizer Wheel - Rear	24 in. (609.6 mm) Notched Ductile Iron
Number of Pulverizer Wheels - Rear	110
Rear Roller Scrapers	Standard
Roller Axle Size	8 in. (203 mm)
Bearing Type	61 mm Heavy-Duty
Type of Shanks	Heavy-Duty Two-Piece Edge Bent Shank 1.75 in. x 0.625 in. (44.5 x 15.9 mm)
Number of Shanks	71
Nominal Shank Spacing	6 in. (152 mm)
Maximum Shank Depth of Operation	5 in. (127 mm)
Under Frame Clearance	23 in. (584 mm)
Hitch	Pull-Type with Hydraulic Lift
Hitch Category	Cat. III, IV or V
Tire Size	(2) 320/70R15 + (4) 480/45R17
Hydraulic Circuits Required	3 (+1 for Rear Accessory)
Wing Hydraulic Down Pressure	Standard
Hydraulic Tooth Control	Single Point Depth Control
Two-Row Coil Tine Harrow	Standard
Rear Hitch	Optional
Front Roller Scraper Kit	Optional
Land Leveler Kit	Optional
V-Leveler Kit	Optional
Rear Three Row Coil Tine Harrow Kit	Optional
LED Warning Lights & SMV Emblem	Standard
Safety Chain Kit	Standard
Powder Coat Paint	Standard
Horsepower Requirements	10 to 14 HP (7.5 to 10.4 kW) per ft.
Recommended Operating Speed	6 to 8 MPH (10 to 13 km/h)

Figure 5-1: Model Specifications

Document Control Revision Log:

Date	Form #	Improvement(s): Description and Comments
10/2020	F-1064-1020	Initial Release
01/2021	F-1064-0121	ECN 46881 - Wing Rest Update
09/2023	F-1064-2309	ECN 46460, 47741, 47749, 48314 - Replumbed Fold Circuit, Hose Asm's ECN 47799, 47818 - Harrow Assemblies, Hyd Cylinders, Wing Lift Asm ECN 47848 - Drawbar Changes ECN 47894, 48122, 48158 - Wing Wheel, Wing Extensions Harrow Asm Orientation Wing Stop Added, Remove Wing Rest Weldments ECN 48178 - Hyd Cyl 4-1/2 x 8 Re-Phase, Midway Vendor Added ECN 48323 - QR Code Decal Removed 20" Wheel Roller Assemblies ECN 48701 - Center Frame Changes ECN 48714, 48741 - Hose Assemblies ECN 48904, 48957, 48979, 49067, 49115 - Change Hinge Fold Links, Wing Rests, Transport Lock, Harrow Tine Clips, Harrow Asm, Coil Drag



Intertek

Equipment from Landoll Company, LLC is built to exacting standards ensured by ISO 9001 registration at all Landoll manufacturing facilities.

Pulvi-Mulcher

3631-36 Models

Re-Order Part Number F-1064

LANDOLL COMPANY, LLC

1900 North Street

Marysville, Kansas 66508

(785) 562-5381

800-428-5655 ~ WWW.LANDOLL.COM



Copyright 2023. Landoll Company, LLC

“All rights reserved, including the right to reproduce this material or portions thereof in any form.”