



Double Seeder Hitch

BDH512

Operator's Manual



LANDOLL CORPORATION

1900 North Street
Marysville, Kansas 66508
(785) 562-5381
800-428-5655 ~ WWW.LANDOLL.COM

Table of Contents

1 Introduction and Safety Information

Introduction	1-1
Description of Unit	1-1
Using this Manual	1-1
Understanding Safety Statements	1-2
Transporting Safety	1-2
Attaching, Detaching and Storage	1-2
Maintenance Safety	1-3
Protective Equipment	1-3
High Pressure Fluid Safety	1-3
Prepare for Emergencies	1-3
Tire Safety	1-3
Safety Chain	1-3

2 Assembly

Drawbar Assembly	2-1
Attach the Pivoting Hitches to the Drawbar	2-3
Attaching the Rear Portion of the Long Hitch to the Front Portion	2-4
Caster Wheel Installation	2-5
Turnbuckle Installation	2-6
Hydraulic Cylinder Installation	2-7
Transport Lock Installation	2-8
Hydraulic Hose Installation	2-9
AG Harness Installation	2-13
S-Tine Tire Track Remover (Optional)	2-14

3 Operations

Hose Set Up for Both Seeders on One Hydraulic Circuit	3-1
Attaching the Seeders	3-2
Transport Lock	3-3
Operating Position	3-4
Transport Position	3-5
Storage	3-6

4 Maintenance

Fasteners	4-1
General Torque Specifications (rev. 4/97)	4-1
Hydraulic Fitting Torque Specifications	4-2
Tires	4-3
Hydraulic System	4-3
Lubrication	4-3

Introduction and Safety Information

Introduction

The implement described in this manual has been designed with care and built by skilled workers using quality materials and processes. Proper assembly and maintenance will provide you with satisfactory use for seasons to come.



DANGER

Read this entire manual before attempting to assemble, adjust or operate this implement. Failure to comply with this warning can result in personal injury or death, damage to the implement or its components and inferior operation.

- Location reference: Right and Left designations in this manual are determined by facing the direction the implement will travel during field operation, unless otherwise stated.

Federal law requires that you explain the safety and operating instructions furnished with this machine to all employees before they are allowed to operate the machine. These must be repeated to the employee's at the beginning of each season. Be sure to observe and follow the instructions for the safety of anyone operating or near the machine.

NOTE

Investigation has shown that nearly 1/3 of all farm accidents are caused by careless use of machinery. Insist that all people working with you or for you abide by all safety instructions.

Description of Unit

The unique design of the Double Seeder Hitch allows for pulling any combination of 8', 10', or 12' pull-type seeders in tandem to expand the seeding width up to a maximum of 24 feet. The over-the-top design maintains a transport width only as wide as the widest seeder. The center flex pivot and wide range of adjustments lets each seeder follow the soil's natural contours for consistent seeder operation. The Double Seeder Hitch incorporates low profile flotation tires on the front frame and a caster wheel and tire on the rear frame to keep wheel tracks in the field to a minimum. The rear tongue utilizes an adjustable hitch plate for easy hook-ups.

Using this Manual

This manual will familiarize you with safety, assembly, operation, adjustment, and maintenance. Read this manual and follow the recommendations to help ensure safe and efficient operation.

- The information in this manual is current at time of printing. Some parts may have changed to assure top performance.

Understanding Safety Statements

You will find various types of safety information on the following pages and on the implement decals (signs) attached to the implement. This section explains their meaning.

NOTICE

Special notice - read and thoroughly understand.



CAUTION

Proceed with caution. Failure to heed caution may cause injury to person or damage product.



WARNING

Proceed with caution. Failure to heed warning will cause injury to person or damage product.



DANGER

Proceed with extreme caution. Failure to heed notice will cause injury or death to person and/or damage product.

NOTE

You should read and understand the information contained in this manual and on the implement decals before you attempt to operate or maintain this equipment.

Examine safety decals and be sure you have the correct safety decals for the implement.

Order replacement decals through your Brillion dealer.

Keep these signs clean so they can be observed readily. It is important to keep these decals clean more frequently than the implement. Wash with soap and water or a cleaning solution as required.

Replace decals that become damaged or lost. Also, be sure that any new implement components installed during repair include decals which are assigned to them by the manufacturer.

When applying decals to the implement, be sure to clean the surface to remove any dirt or residue. Where possible, sign placement should protect the sign from abrasion, damage, or obstruction from mud, dirt, oil etc.



DANGER

- Do not allow anyone to ride on the tractor or implement. Riders could be struck by foreign objects or thrown from the implement.
- Never allow children to operate equipment.
- Keep bystanders away from implement during operation.

Transporting Safety

IMPORTANT

It is the responsibility of the owner/operator to comply with all state and local laws.

When transporting the implement on a road or highway, use adequate warning symbols, reflectors, lights and slow moving vehicle sign as required. Slow moving tractors and towed implements can create a hazard when driven on public roads. They are difficult to see, especially at night.

Do not tow an implement that, when fully loaded, weighs more than 1.5 times the weight of the towing vehicle.

Carry reflectors or flags to mark the tractor and implement in case of breakdown on the road.

Do not transport at speeds over 20 MPH under good conditions. Never travel at a speed which does not allow adequate control of steering and stopping. Reduce speed if towed load is not equipped with brakes

Avoid sudden stops or turns as the weight of the implement may cause the operator to lose control of the tractor. Use a tractor heavier than the implement.

Use caution when towing behind articulated steering tractors; fast or sharp turns may cause the implement to shift sideways.

Keep clear of overhead power lines and other obstructions when transporting. Know the transport height and width of your implement.

Attaching, Detaching and Storage

- Do not stand between the tractor and implement when attaching or detaching implement unless both are prevented from moving.
- Before applying pressure to the hydraulic system, be sure all connections are tight and that hydraulic lines and hoses are not damaged.
- Block implement so it will not roll when unhitched from the tractor.

Maintenance Safety

- Block the implement so it will not roll when working on or under it to prevent injury.
- Do not make adjustments or lubricate the machine while it is in motion.
- Make sure all moving parts have stopped.
- Understand the procedure before doing the work. Use proper tools and equipment.

Protective Equipment

- Wear protective clothing & equipment appropriate for the job. Avoid loose fitting clothing.
- Because prolonged exposure to loud noise can cause hearing impairment or hearing loss, wear suitable hearing protection, such as earmuffs or earplugs.

High Pressure Fluid Safety

Escaping fluid under pressure can be nearly invisible and have enough force to penetrate the skin causing serious injury. Use a piece of cardboard, rather than hands, to search for suspected leaks.

Any fluid injected into the skin must be surgically removed within a few hours or gangrene may result.

Avoid the hazard by relieving pressure before disconnecting hydraulic lines.

Prepare for Emergencies

- Keep a First Aid Kit and Fire Extinguisher handy
- Keep emergency numbers for the doctor, ambulance, hospital and fire department near the phone.

Tire Safety

Tire changing can be dangerous and should be performed by trained personnel using correct tools and equipment.

When inflating tires, use a clip-on chuck and extension hose long enough to allow you to stand to one side, not in front of or over the tire assembly. Use a safety cage if available.

When removing and installing wheels use wheel-handling equipment adequate for the weight involved.

Safety Chain

Use the safety chain to help control drawn machinery should it separate from the tractor drawbar.

Use a chain with a strength rating equal to or greater than the gross weight of towed machinery, which is 11,000 pounds minimum in accordance with ASAE S338.2 specifications. If two or more implements are pulled in tandem, a larger chain may be required. Chain capacity must be greater than the TOTAL weight of all towed implements.

A second chain should be used between each implement.

Attach the chain to the tractor drawbar support or specified anchor location. Allow only enough slack in the chain to permit turning. The distance from hitch pin to attachment point or intermediate support point should not exceed 9 inches. See Figure 1-1.

Replace the chain if any links or end fittings are broken, stretched or damaged.

Do not use a safety chain for towing.

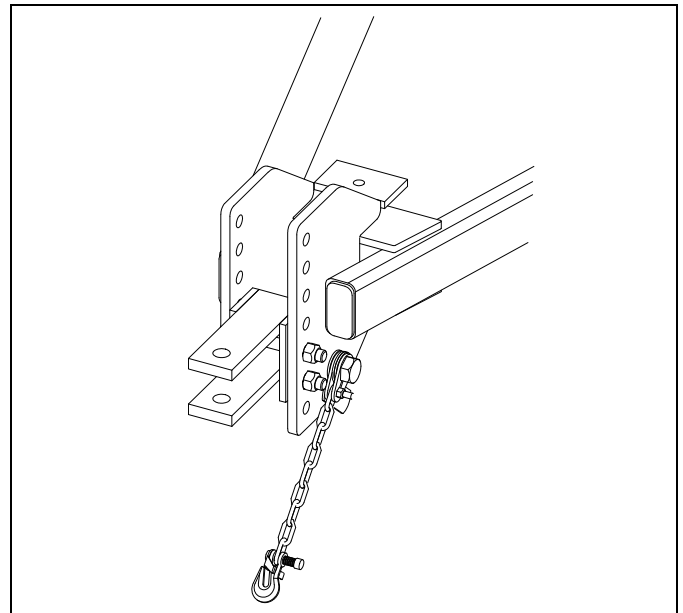

Figure 1-1 Safety Chain

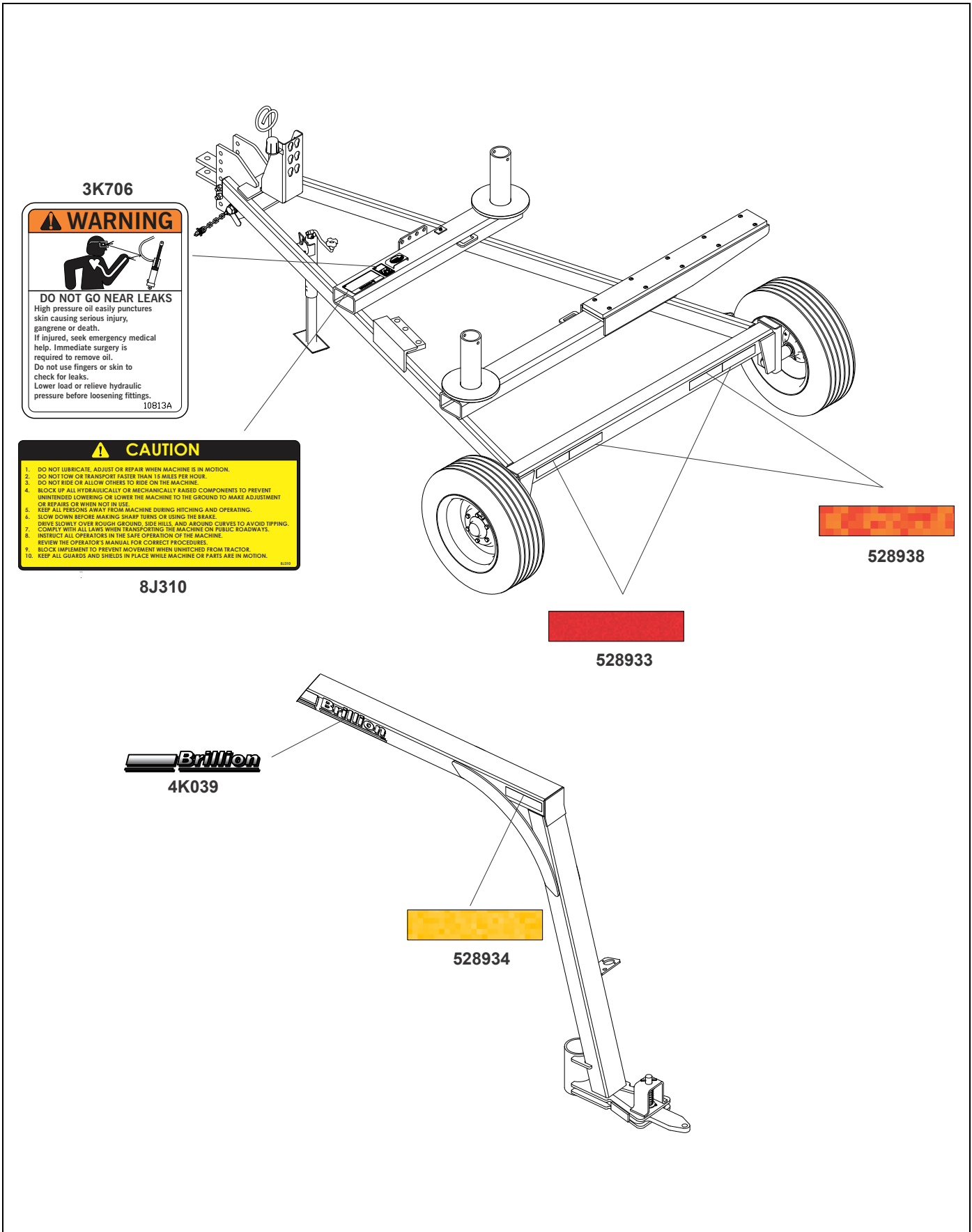

Figure 1-2: Safety Decal Locations (1 of 2)

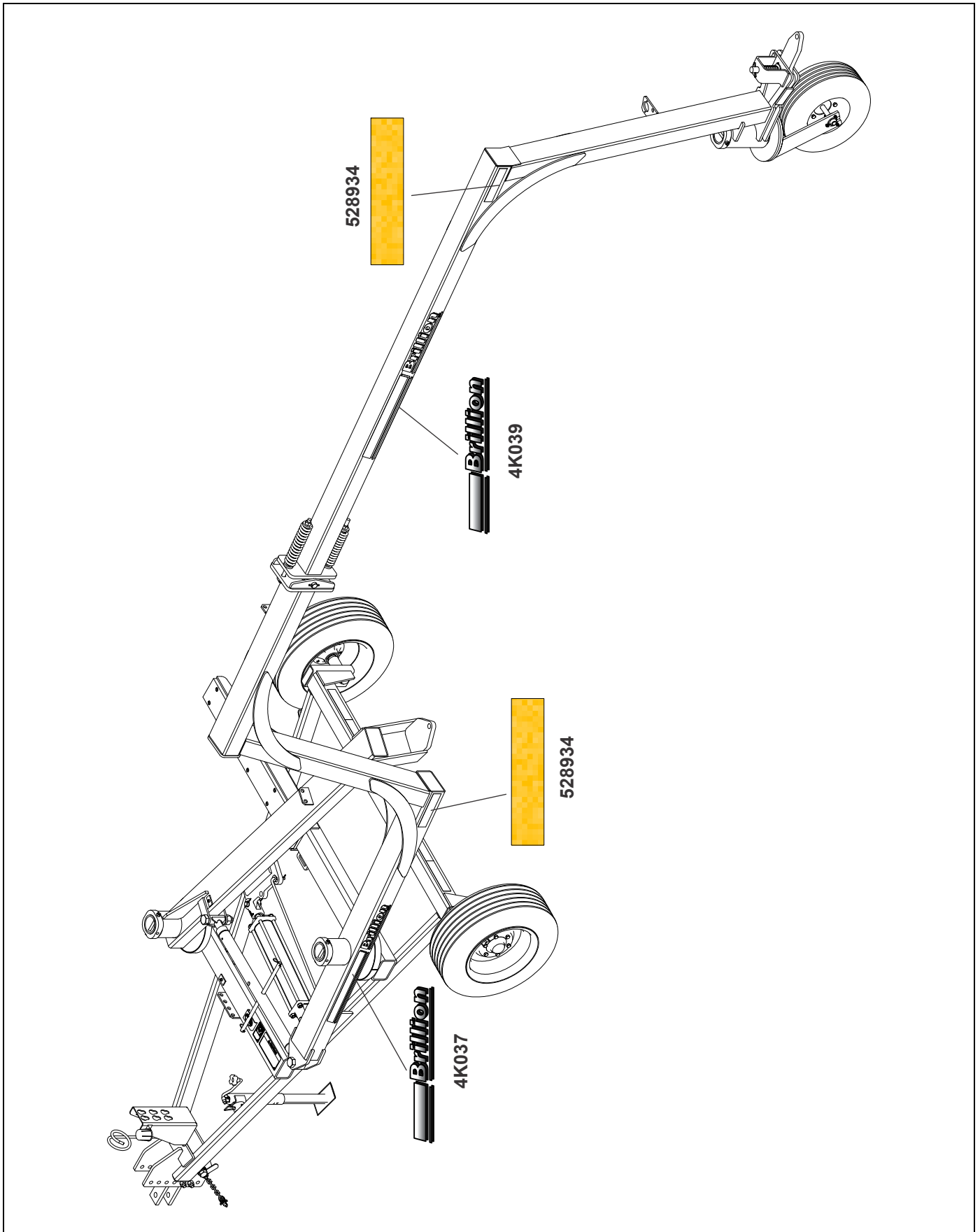

Figure 1-3: Safety Decal Locations (2 of 2)

Page Intentionally Blank

Chapter 2

Assembly

The intent of this chapter is to provide proper assembly instructions for the implement. The reference numbers on the following pages provide an indication of assembly order. Refer to Parts Manual F-646 for complete part breakdowns and proper location of any parts not shown in the following illustrations.

Location reference: Right and Left designations in this manual are determined by facing the direction the implement will travel during field operation, unless otherwise stated.

6. Attach Hose Holder and Hose Support with a 5/8-11 x 2-1/4 Hex Capscrew, Flat Washer and Locknut. See Figure 2-2.
7. Attach Connector Holder with two 1/4-20 x 3/4 Hex Capscrew and Flange Locknut.



CAUTION

Do not work on or under this machine unless securely blocked and supported by a hoist or tractor or by other sufficient means!

IMPORTANT

If a pre-assembled component or fastener is temporarily removed, ensure it is correctly re-installed per these instructions.

Check that all working parts move freely, bolts are tight and cotter pins are spread.

See page 4-1 in the Maintenance Chapter for proper bolt torque values.

Note the different torque requirement for bolts with lock nuts.

Select a smooth level area that can be reached by a hoist or lift truck.

Drawbar Assembly

1. Attach each Hub and Spindle with a 3/8-16 x 3 Hex Capscrew and Locknut. See Figure 2-1.
2. Attach a Wheel and Tire Assembly to each Hub and Spindle with six 1/2-20 x 1 Wheel Bolts.
3. Install Jack.
4. Attach Safety Chain using one 1-8 x 2-3/4 Hex Capscrew, three Flat Washers and one Lock Nut.
5. Attach 4K636 Hitch using two 3/4-10 x 6-1/2 Hex Capscrews and Locknuts.

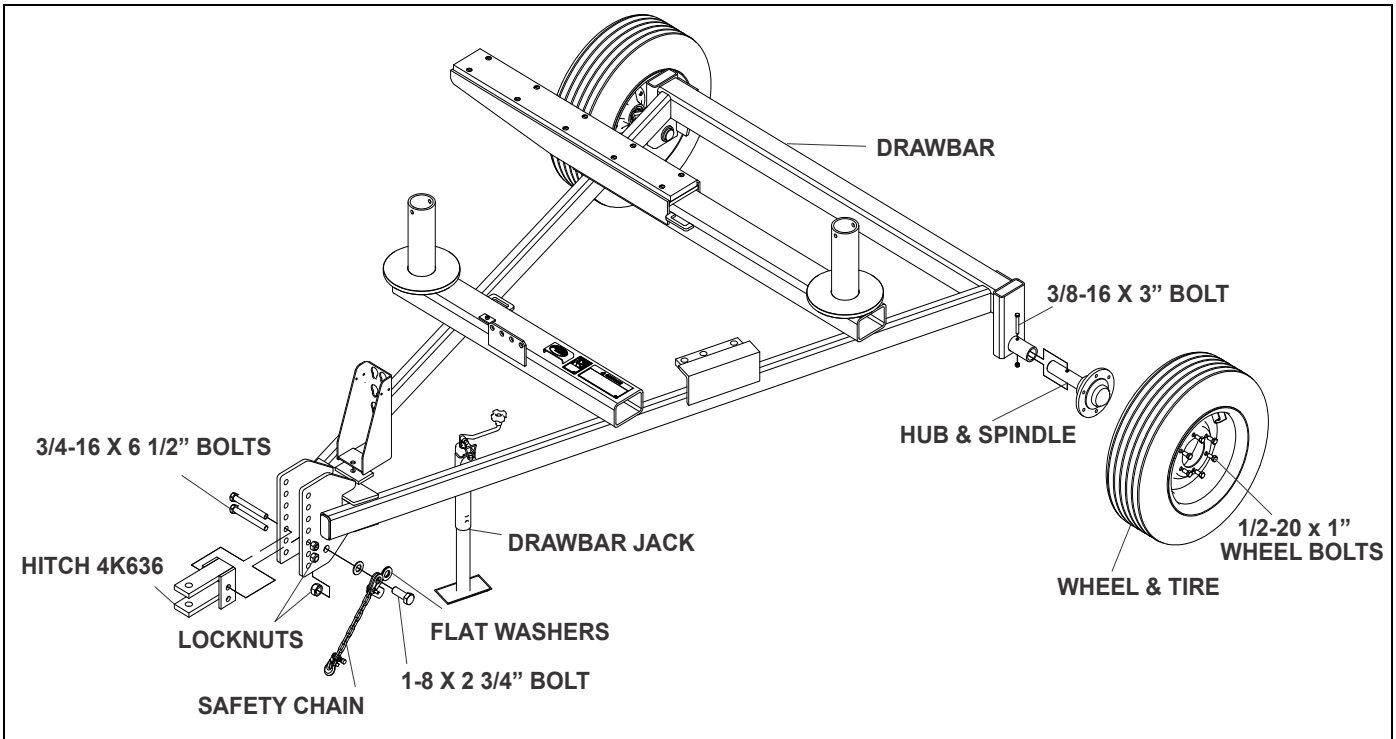

Figure 2-1: Drawbar Assembly

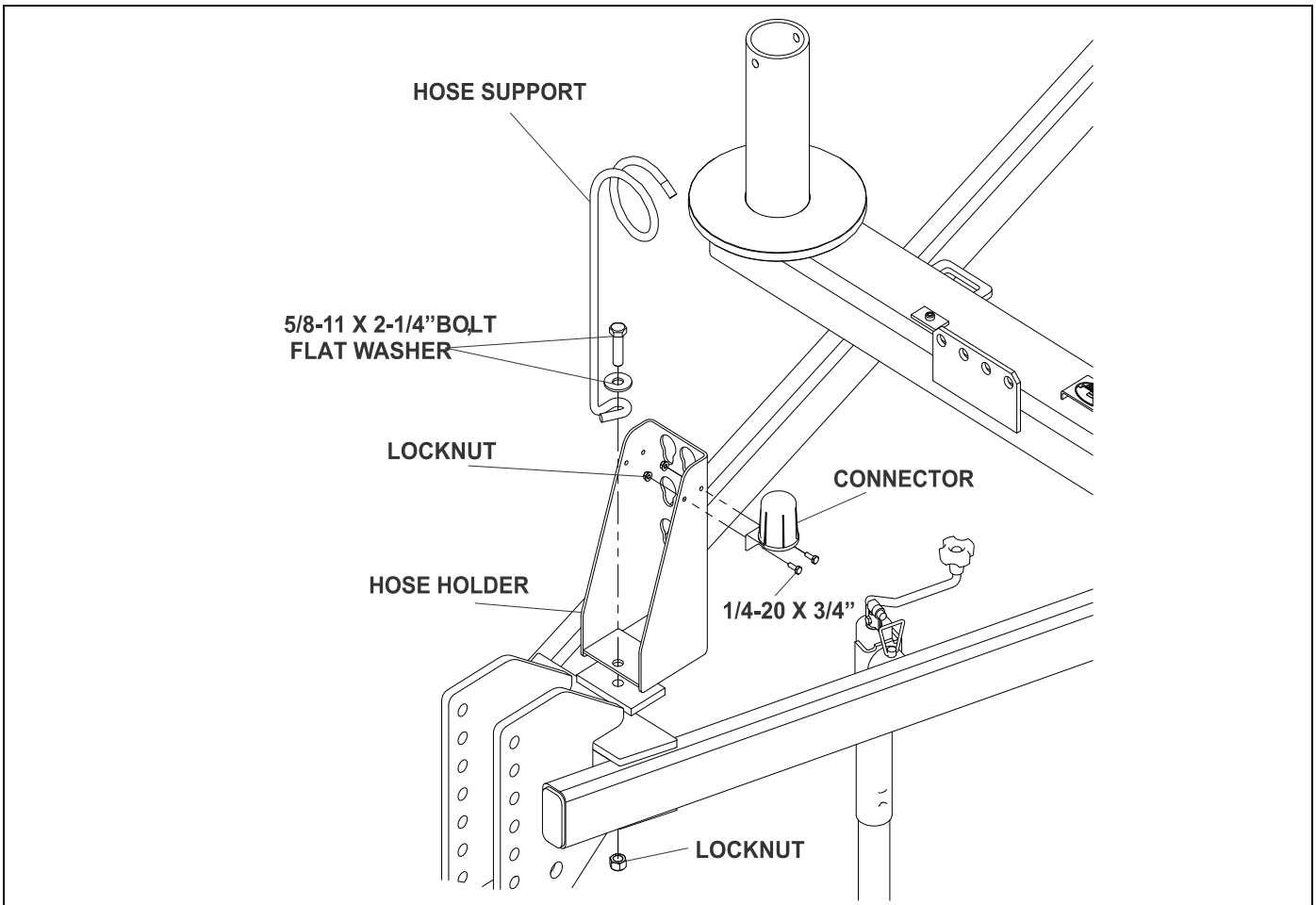

Figure 2-2: Drawbar Assembly

Attach the Pivoting Hitches to the Drawbar

1. Slide a Wear Disk and then a Bushing over each pipe on the Drawbar,
2. Slide the Short Hitch onto the drawbar front pipe and the Long Hitch onto the drawbar rear pipe.
3. Each Keeper Plate has 2 sets of holes. Position it so that the smallest gap as possible is between the Keeper Plate and the Hitch Pipe. Line the appropriate hole up with the drawbar pipe and secure in place with a 1/2-13 x 6 Hex Capscrew and Locknut.

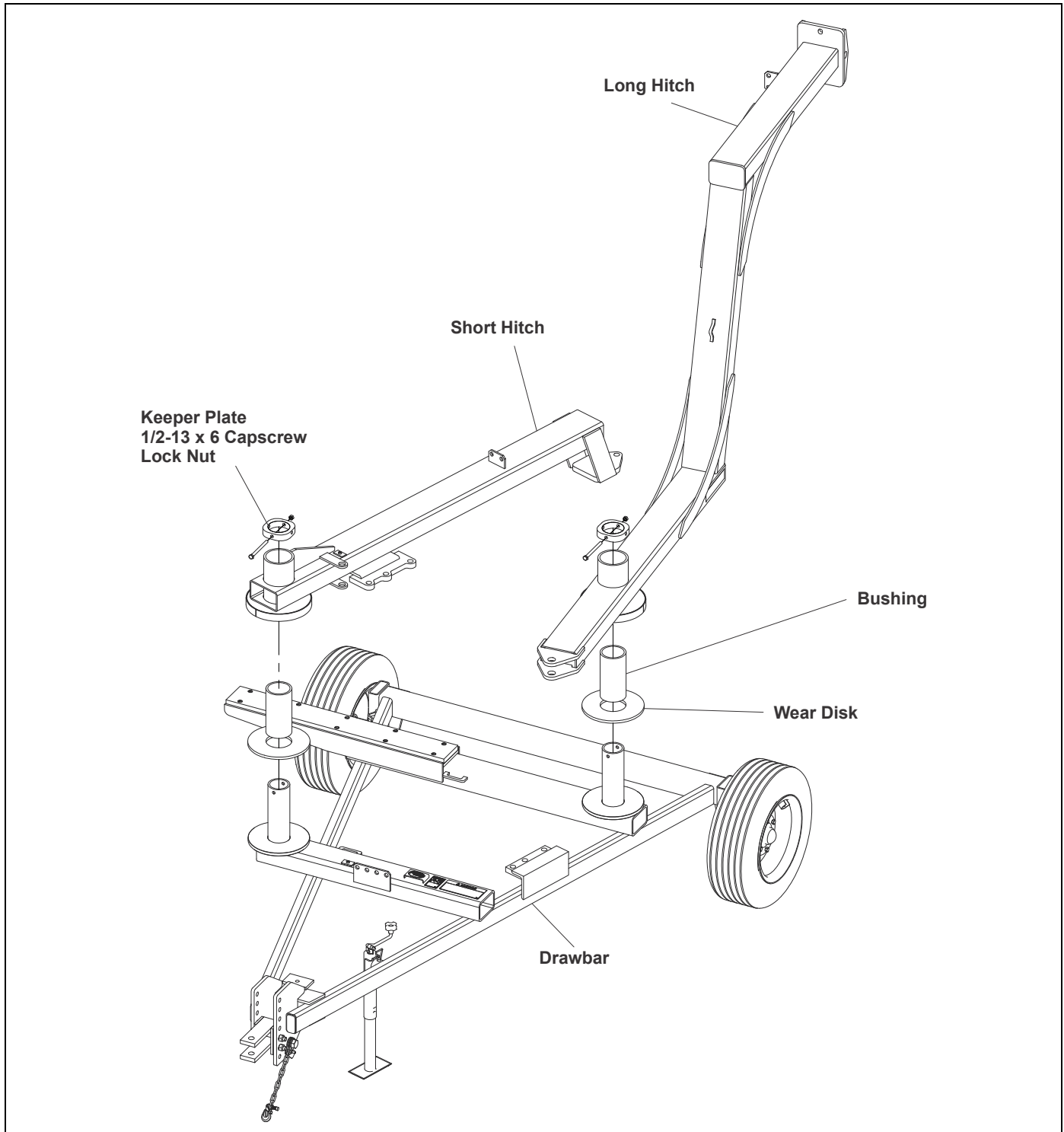

Figure 2-3: Pivoting Hitches

Attaching the Rear Portion of the Long Hitch to the Front Portion

NOTE

The Spring bolts should be installed with the threaded end pointed to the rear to prevent the threads from wearing within the slots.

1. Place the sleeve of the Rear Hitch rear portion between the lugs of the Rear Hitch front portion. Install pin and roll pins.

2. Install cushion by installing two Spring Bolts, six 3/8" Thick Washers, two Inner and Outer Compression Springs and two 3/4-10 Locknuts into the front and rear portions of the rear Hitch as shown.
3. Tighten the bottom Locknut so that 1-1/2" of thread is exposed.
4. Tighten the top Locknut so that 1/4" of thread is exposed.

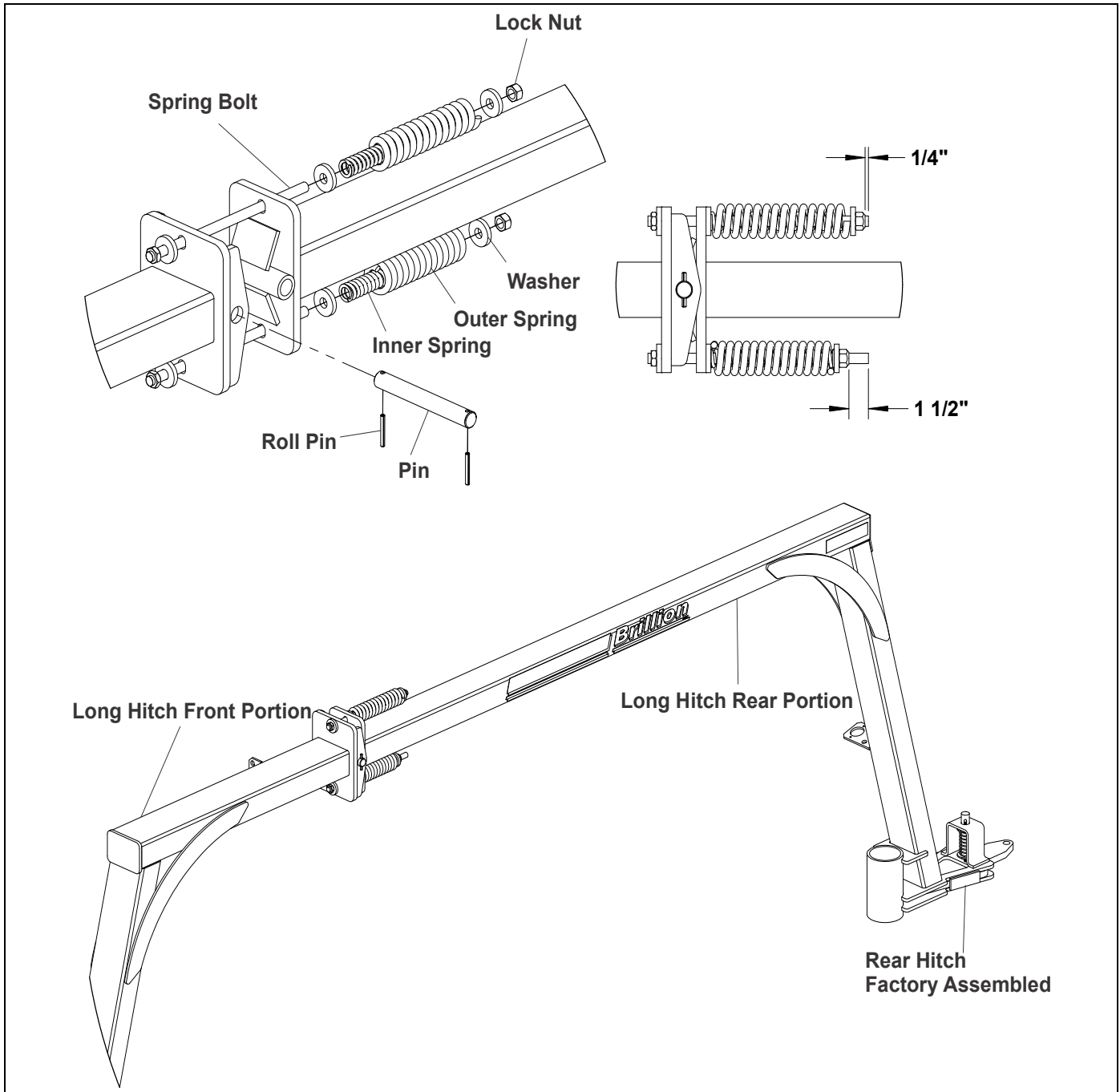

Figure 2-4: Rear to Front Hitch Installation

Caster Wheel Installation

1. Slide the Wear Disk and Bushing onto the Caster Assembly Pipe.
2. Slide the Caster Assembly Pipe onto the Rear Hitch.
3. The Keeper Plate has two sets of holes. Position it so that the smallest gap as possible is between the Keeper Plate and the Rear Hitch Pipe. Line the appropriate hole up with the Caster assembly Pipe and secure in place with a 1/2-13 x 6 Hex Capscrew and Locknut.

4. Remove the Rear Seeder Drawbar Hitch and replace it with 1P885 Hitch which is longer.

NOTE

Locking collars should be tightened in normal direction of rotation.

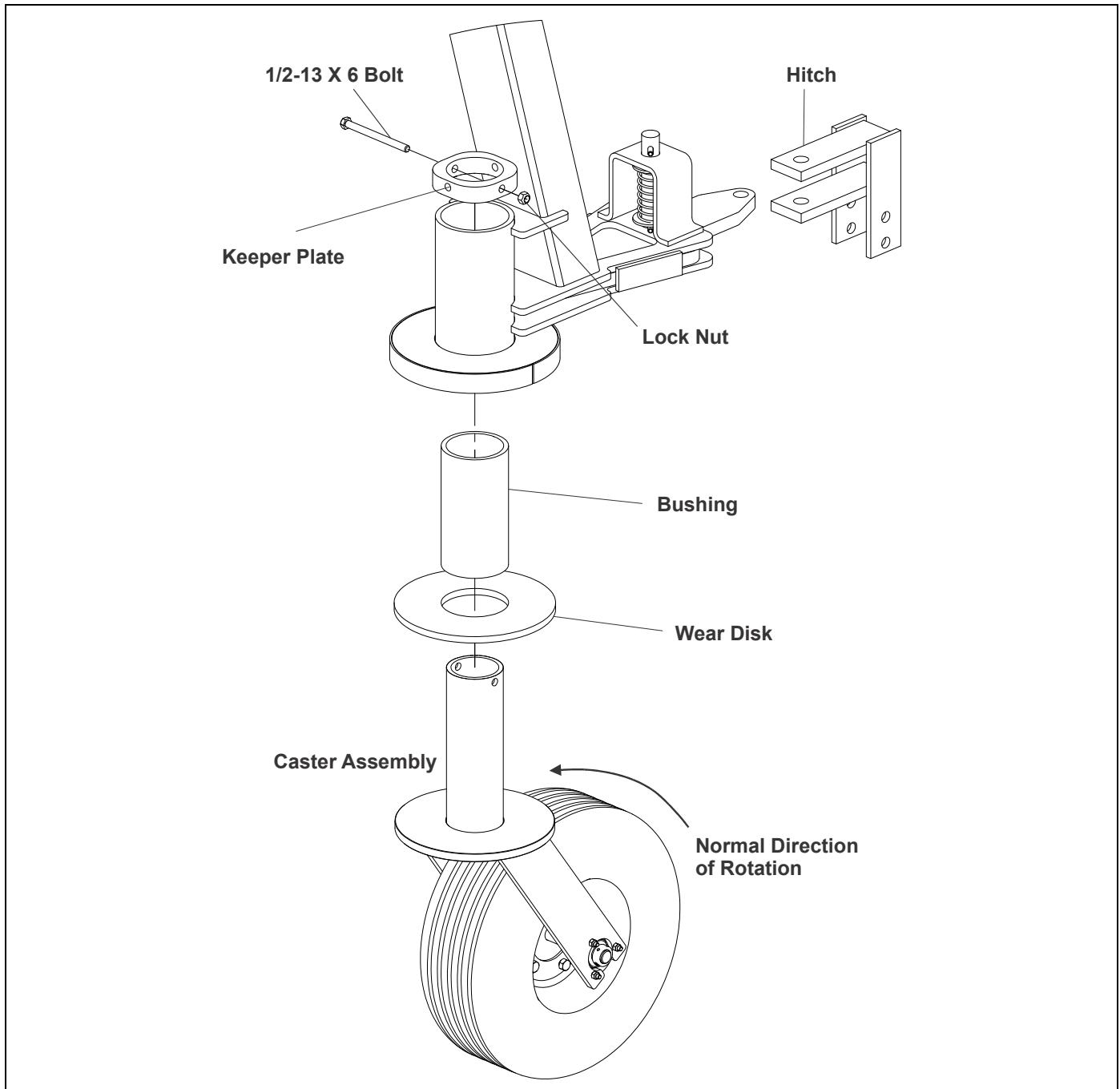

Figure 2-5: Caster Wheel

Turnbuckle Installation

The turnbuckle is used to adjust the overlap of the seeders. The hitch is designed so that the left side of the front seeder will follow exactly on the center line of the tractor.

1. With the Turnbuckle grease fittings facing forward, install the square end of the turnbuckle between the lugs on the Long Hitch. Secure in place with 1 1/4-7 x 5" Hex Capscrew and Locknut.

2. Install bushing end of the Turnbuckle between the lugs on the Short Hitch. Secure in place with 1- 1/4 x 6-1/2 Hex Capscrew and Locknut.

NOTE

When using seeders of different widths, always attach the wider seeder to the front hitch, and adjust the location of the rear seeder by using the turnbuckle.

3. Apply the Brillion decal to the outer tube of the Short Hitch and the Long Hitch.

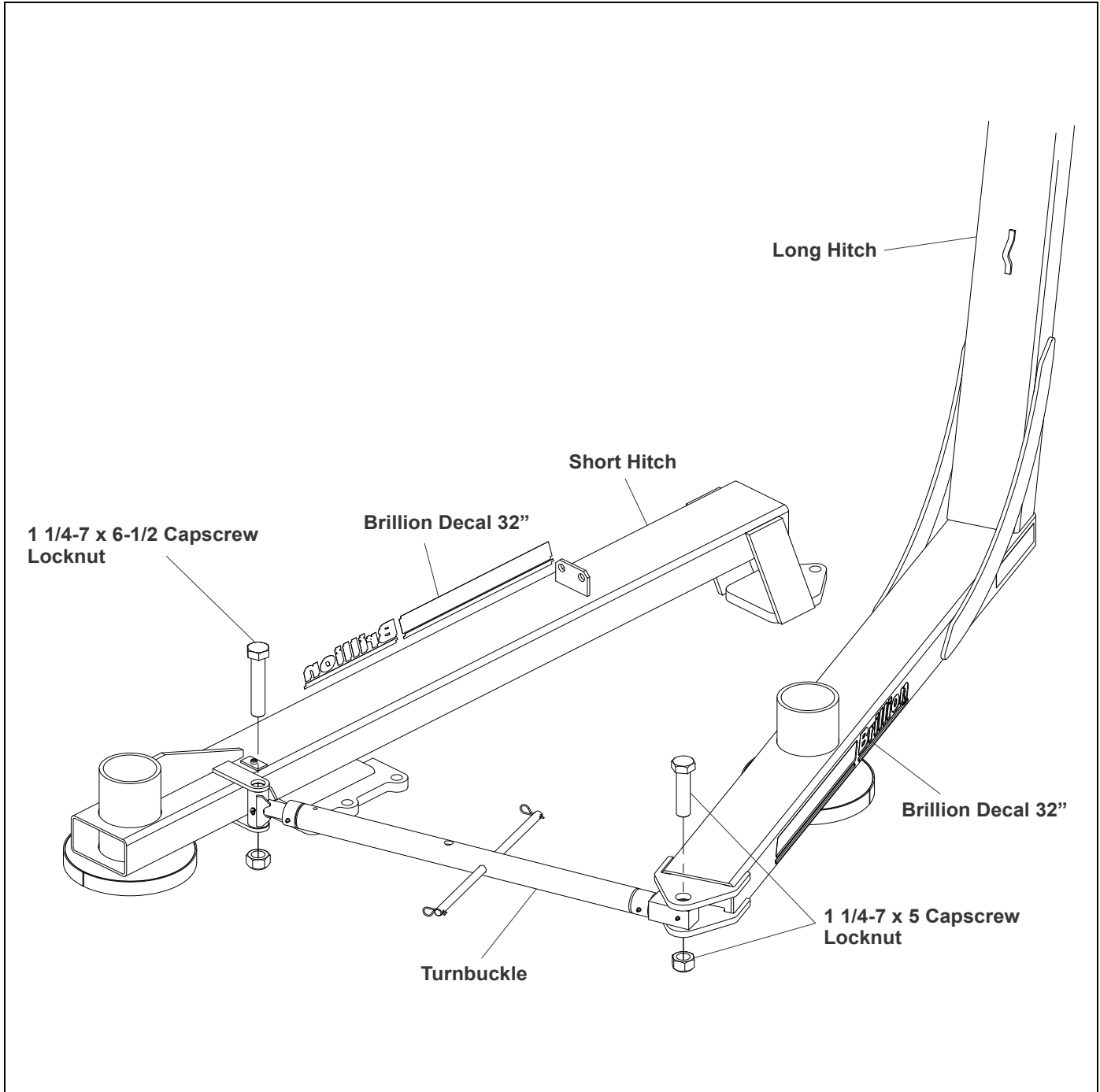

Figure 2-6: Turnbuckle Installation

Hydraulic Cylinder Installation

1. With the Cylinder ports facing forward and using the Pin and Cotter Pins provided with the Cylinder, attach the base end of the Cylinder to the proper hole in the 3 hole plate on the Drawbar Frame based on the seeder width being used. See Figure 2-7.
 2. Attach the rod end of the Cylinder into the appropriate Short Hitch Lug hole, based on the width of the seeders being used, using the Pin and Cotter Pins provided with the cylinder.
- If you are using two 12 foot wide seeders, the front holes are used for mounting the cylinder.

- If you are using the two 10 foot wide seeders, use the middle holes.
- If you are using two 8 foot wide seeders, use the rear holes.

NOTE

If using two seeders of different widths, attach the wider seeder to the front hitch, and use the cylinder attaching holes specified for the wider seeder.

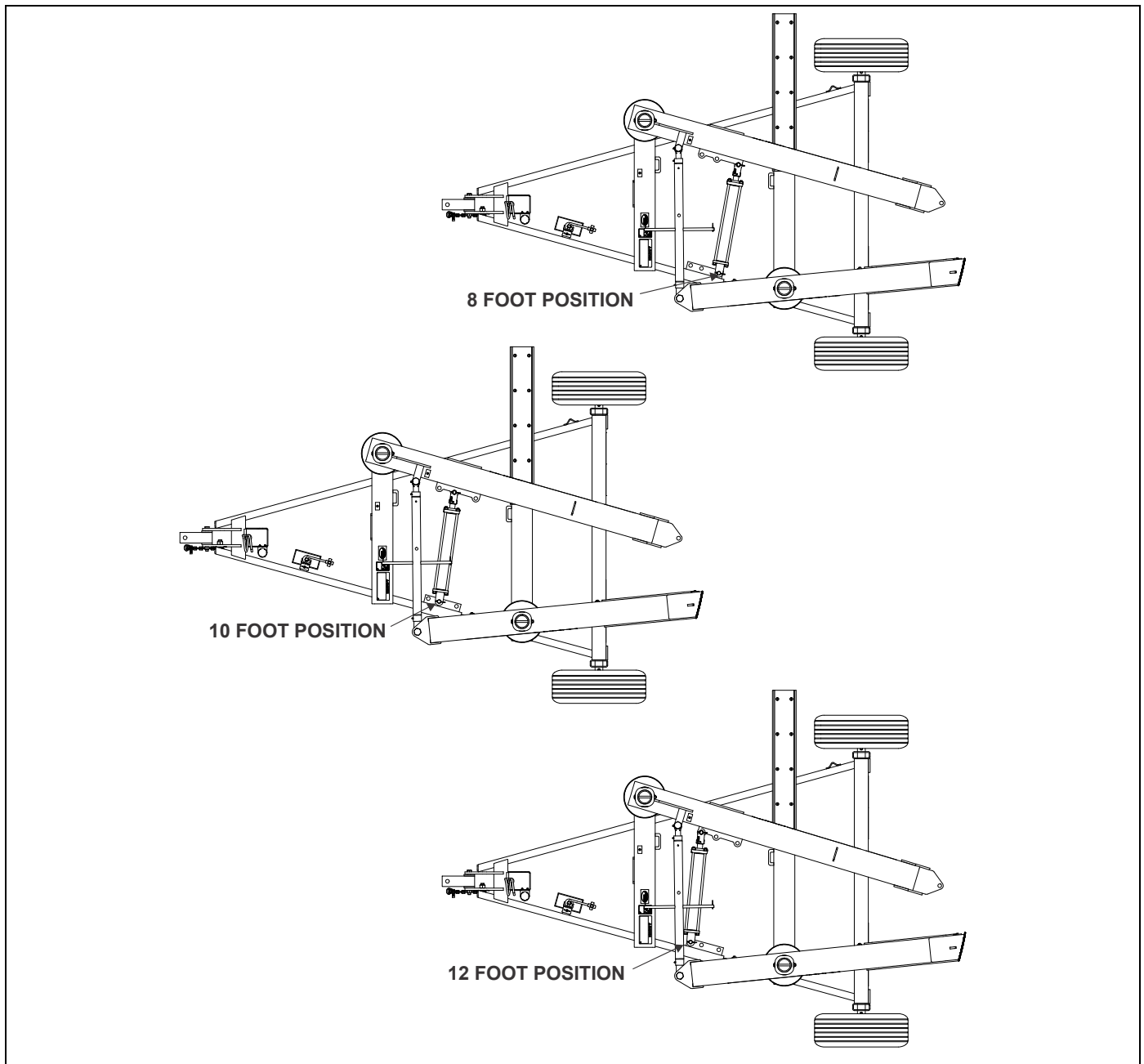

Figure 2-7: Hydraulic Cylinder Installation

Transport Lock Installation

Remove the Flat Washer and Cotter Pin from the Transport Lock and insert it in the proper hole in the 3 hole plate on the Drawbar Frame based on the seeder width being used.

Remove the hair pin from the transport lock and install it in either the slot on the Drawbar Frame (Operating Position) or into the appropriate hole in the Short Hitch 3 hole Lug (Transport Position).

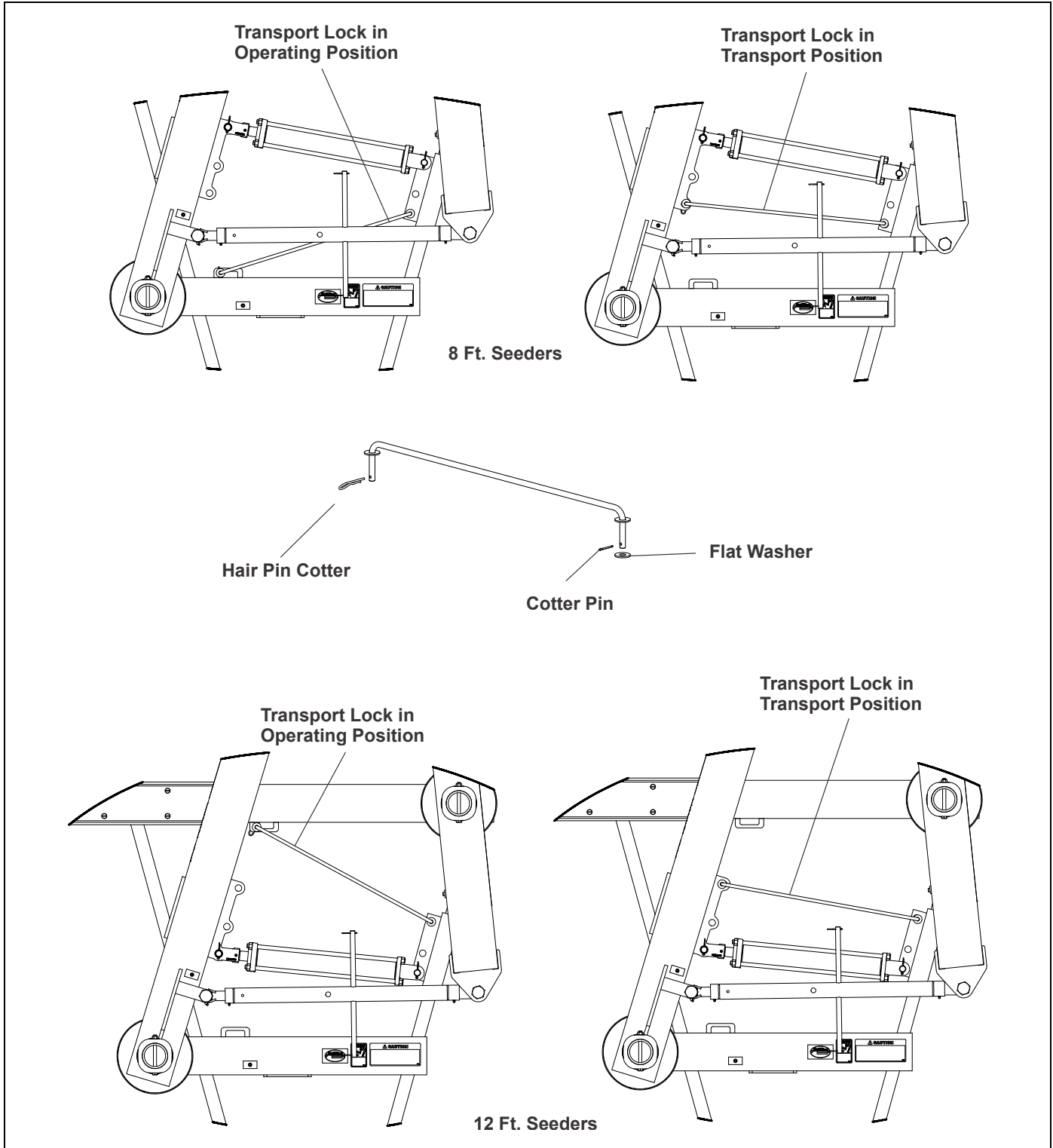

Figure 2-8: Transport Lock Installation

Hydraulic Hose Installation



WARNING

Escaping fluid under pressure can be nearly invisible and have enough force to penetrate the skin causing serious injury. Use a piece of cardboard, rather than your hands, to search for suspected leaks. Wear protective gloves & safety glasses or goggles when working with hydraulic systems.

Avoid the hazard by relieving pressure before disconnecting hydraulic lines.

NOTE

On most tractors this can be done by putting the valve controls in the float position before the engine is stopped.

Tightening Procedure For JIC 37° Swivel Female Nuts

1. Check flare and seat for defects.
2. Lubricate the connection.
3. Install hoses without twists.
4. Hand tighten until connection bottoms.
5. Using 2 wrenches to prevent twisting, rotate the swivel nut 2 wrench flats (1/3 turn).
6. For reassembly, follow the same procedure but tighten only 1 wrench flat (1/6 turn).

Tightening Procedure For Swivel O-ring Fittings

1. Lubricate o-ring and install the fitting until the metal washer that backs up the o-ring contacts the face of the boss.
2. Orient the fitting by turning counterclockwise up to 1 turn.
3. Tighten the lock nut using 50-60 foot pounds torque.

NOTE

As you assemble hoses to fittings leave hose ends loose enough on the fittings so that they can pivot as the hose is being securely clamped to the hitch.

Use the Hydraulic Schematic as a reference: See Figure 2-9.

1. Lube all o-ring connections. Install the hydraulic fittings. See Figures 2-10 and 2-11.
2. Starting at the Rear Hitch bulkhead plate just above the Caster Wheel, Install the Hydraulic Hoses. See Figures 2-10 and 2-11.
3. To prevent excess wear, wrap the two hoses near the spring cushion with Hose Wrap. See Figure 2-10.
4. Secure the hoses in place with Hose Clamps and Cable Ties provided.

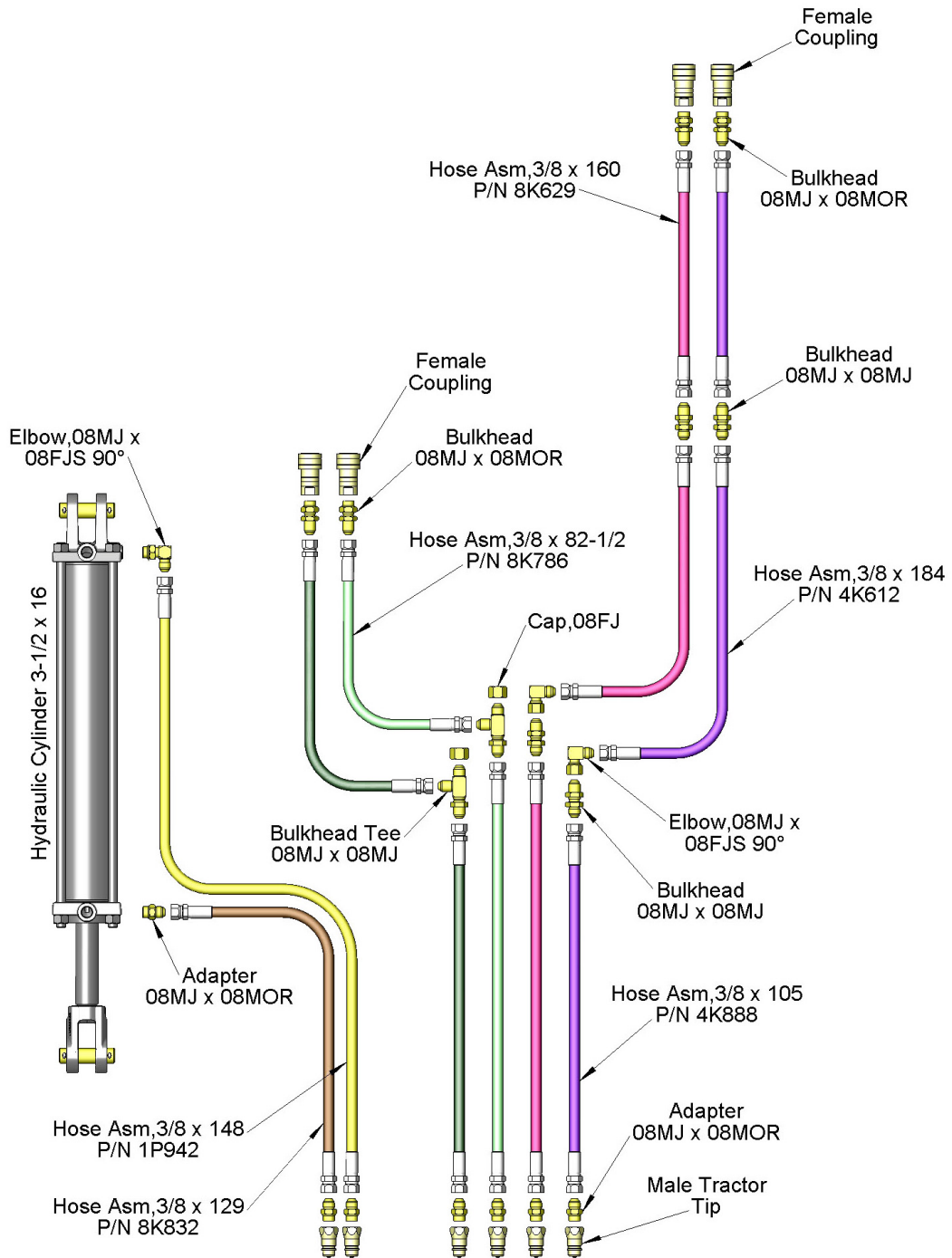

Figure 2-9: Hydraulic Schematic

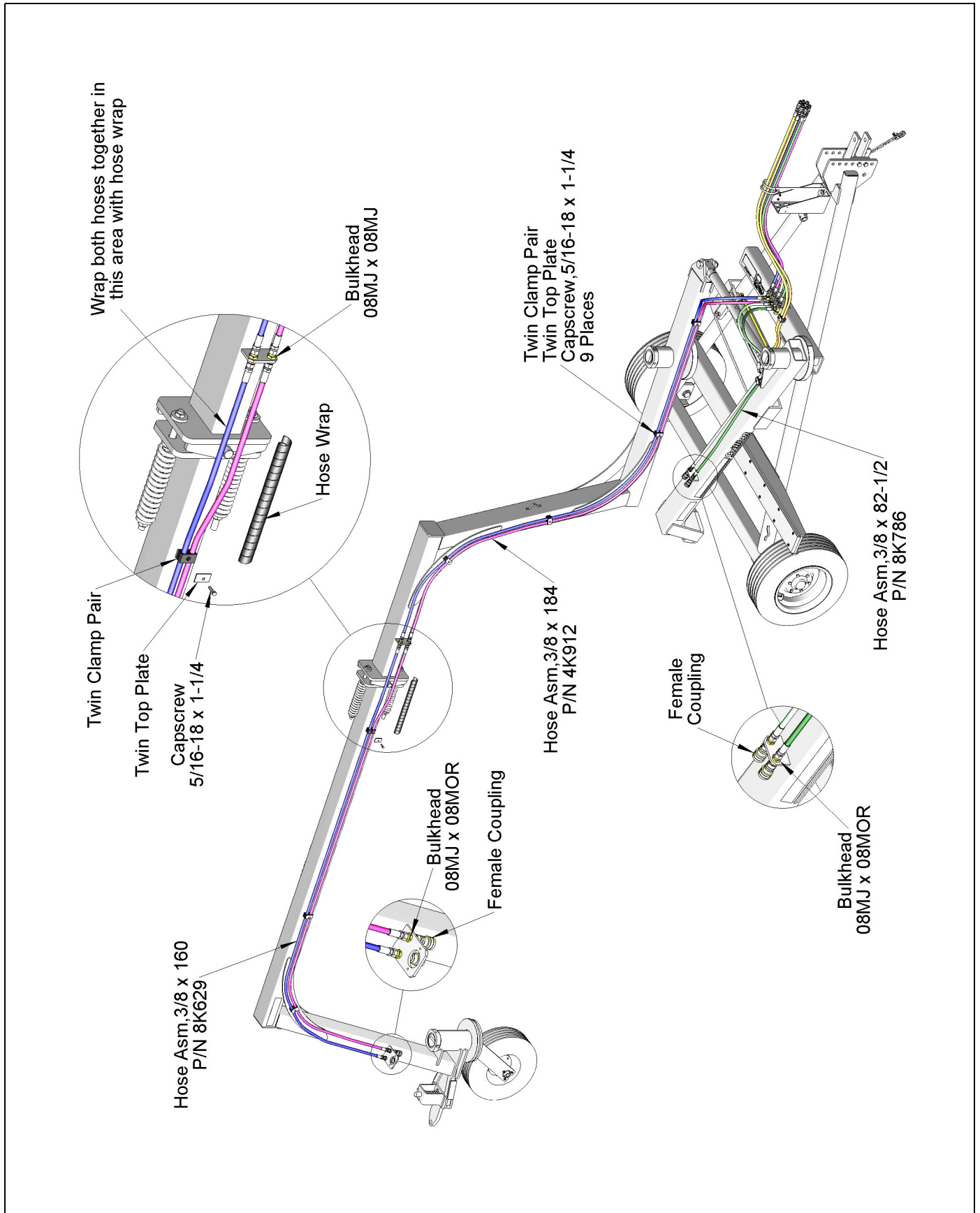

Figure 2-10: Hydraulic Hose Installation - 1 of 2

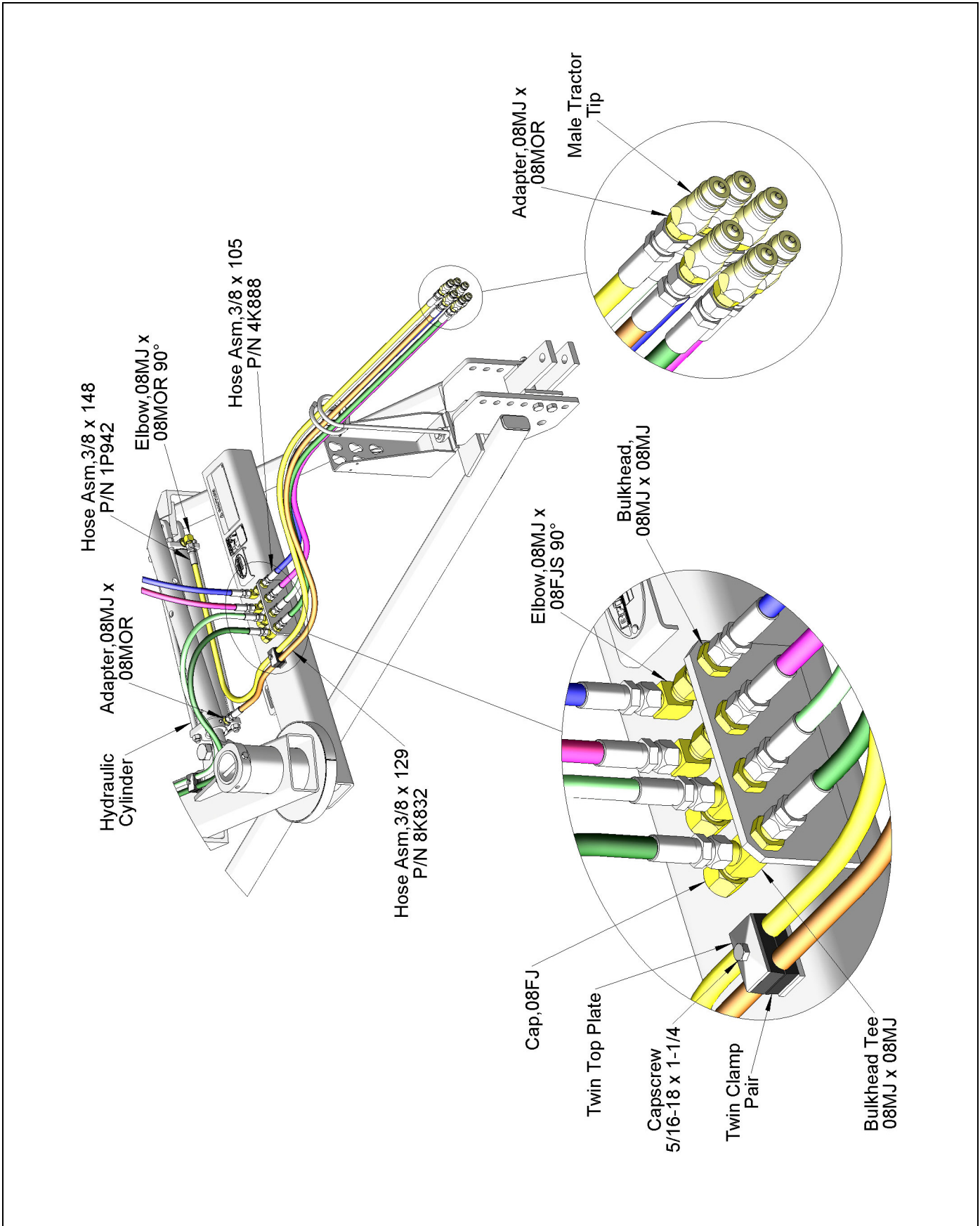

Figure 2-11: Hydraulic Hose Installation - 2 of 2

AG Harness Installation

1. Attach Tandem Hauler Adapter to Rear Hitch Bulkhead just above the Caster Wheel Assembly. Secure with two 1/4-20 x 1" Hex Capscrew and Flange Locknut.
 2. Plug Ag Harness's flat plug into Tandem Hauler Adapter.
 3. Run Ag Harness forward along the hydraulic hoses securing cord to hoses where necessary with provided cable ties.
 4. 7-pin Plug end connects to the tractor or is stored in connector Holder located on the Hose Holder Bracket that is mounted to the Drawbar. Allow enough harness length to reach tractor socket. Roll or fold up excess if necessary with provided cable ties.
- Clutch wiring should follow the same path as the Ag Harness from the tractor to the Rear Seeder

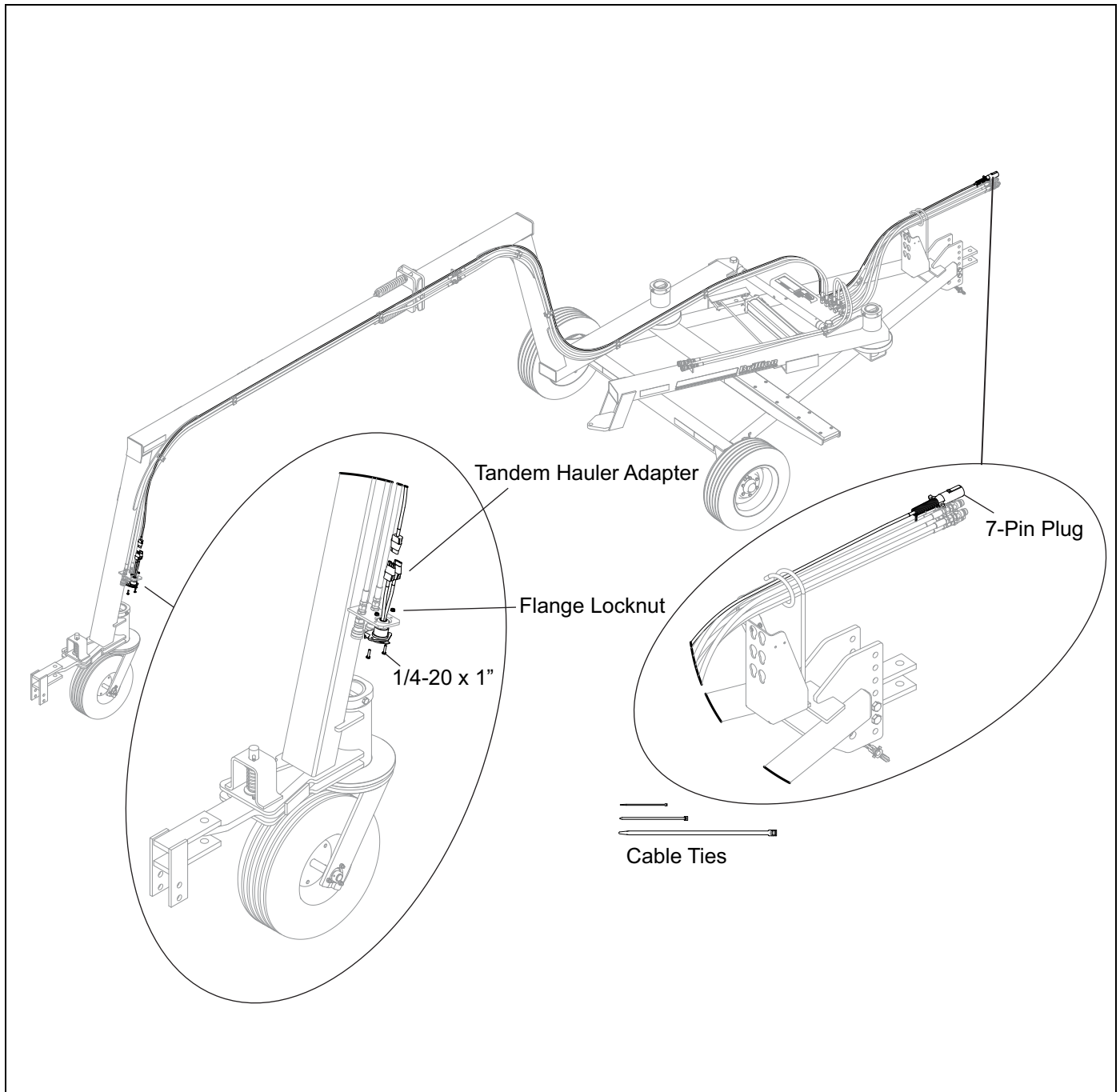

Figure 2-12: AG Harness Installation

S-Tine Tire Track Remover (Optional)

1. Attach brackets to the frame with U-bolts (1/2-13 x 4-1/2" centers x 7-1/2" deep), lock washers, and nuts. Note that the long ends of the brackets are downward. The bracket on the Transmission side should be about 13-1/8" from the frame inner plate and on the opposite side 10-1/4" from the frame inner plate. See Figures 2-14, 2-15.
2. Attach the tube to brackets using straps and bolts (1/2-13" x 6"), lock washers, and nuts. At this time ensure the hydraulic hoses are positioned over the top of the Brackets. See Figures 2-14, 2-15.
3. Locate and install the S-tines to cover the tractor tire tracks. The first tine on the front is 15-3/8" and the first tine on the rear seeder is 18-3/8" from the end of the long tube. The rest of the tines are positioned 7-1/2 inches apart consecutively inwards towards the center of the hitch or tractor. See Figures 2-14, 2-15.

NOTE

Duckfoot points on each end and 6 reversible points in between.

4. If needed, additional tines may be purchased and installed.

The Wheel Track Remover is furnished with 16 S-tines. Additional or fewer tines may be used as required.

NOTE

Tube 9J962 provided with this kit is for 12 foot models, it will need to be cut to size for 8 foot and 10 foot models.

NOTE

S-tines should not be operated any deeper than necessary to remove tractor tire tracks. Otherwise, wet soil is brought up which will stick to the rollers, draft load is increased, and under some conditions, tines may deflect back to rollers and break. See Figure 2-13.

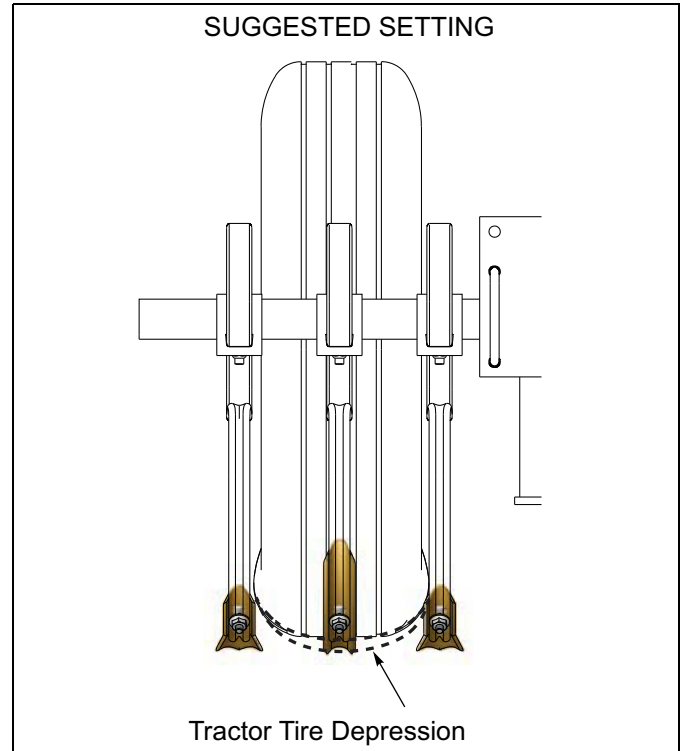

Figure 2-13: Tractor Tire Depression

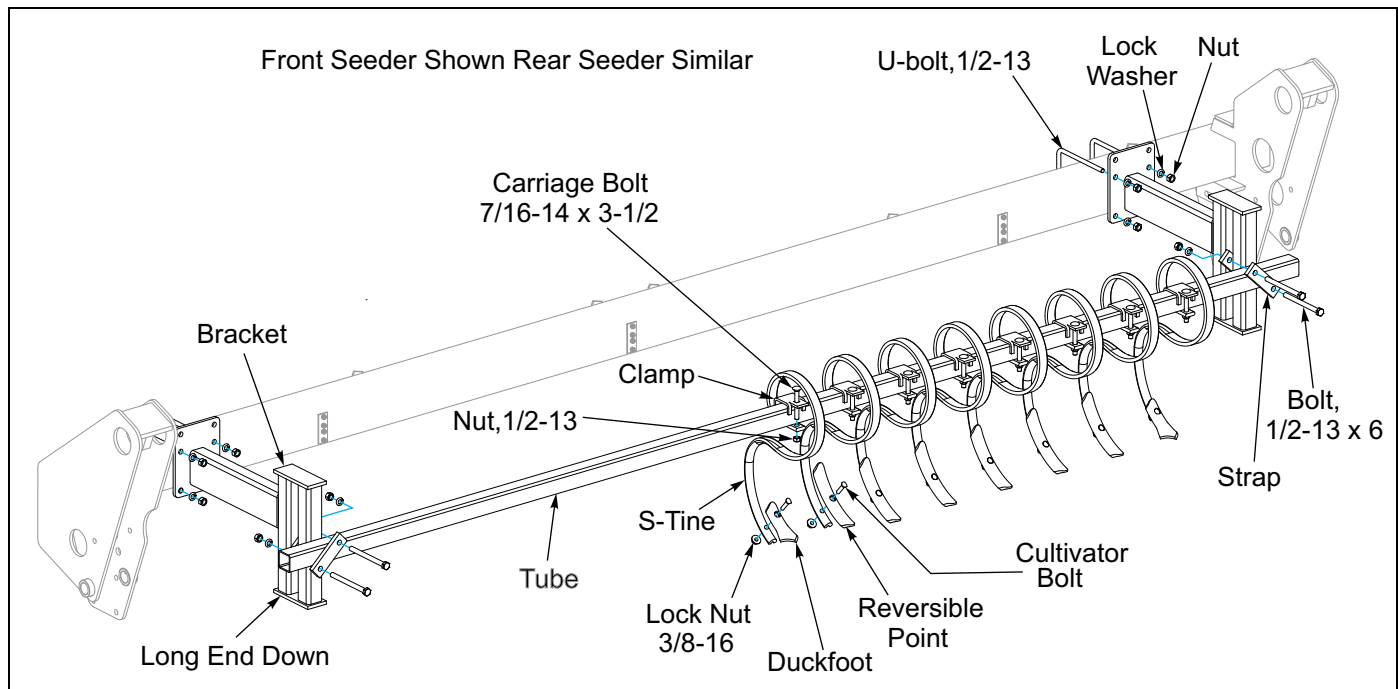

Figure 2-14: S-Tine

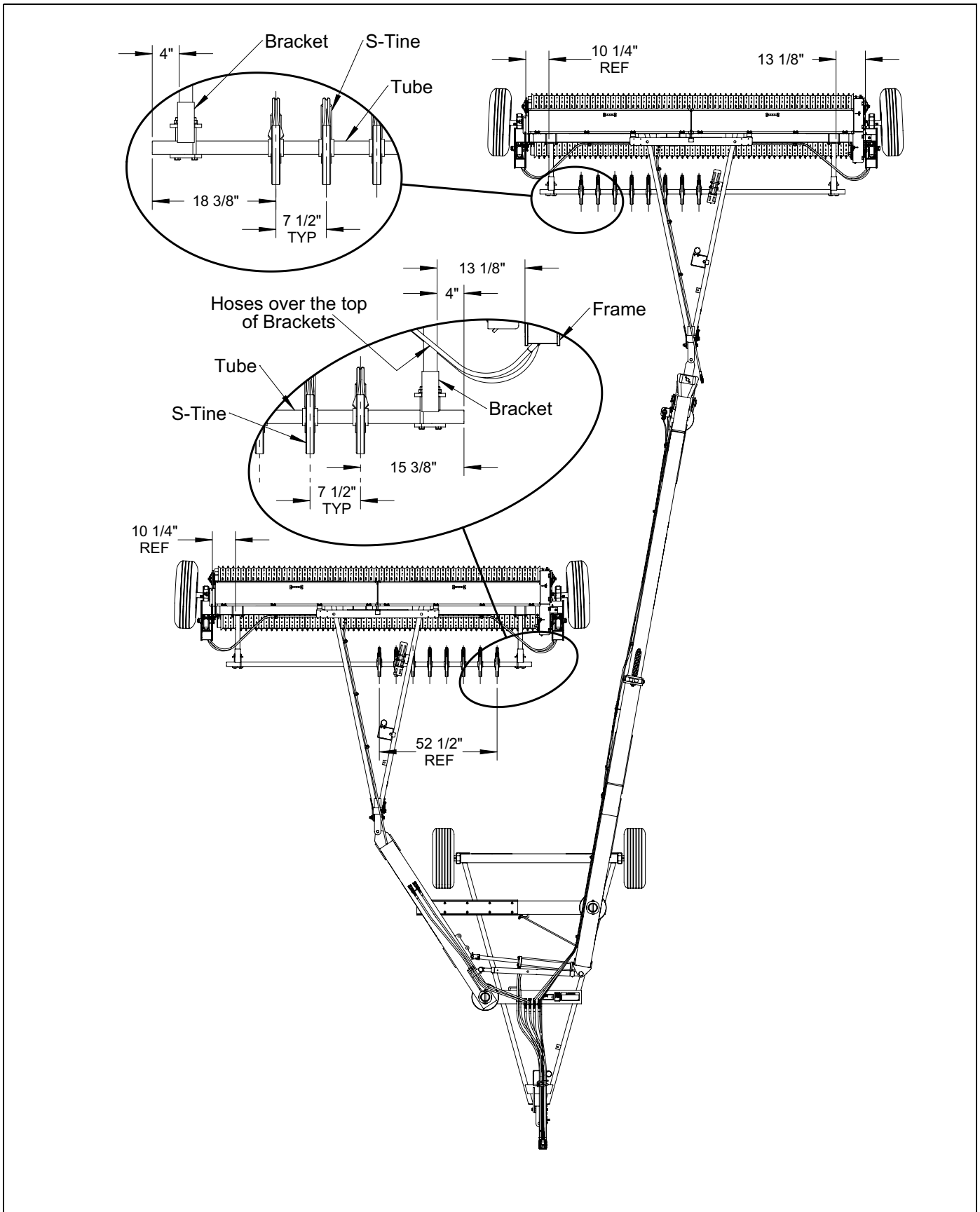

Figure 2-15: Optional - S-Tine Track Remover Kit

IMPORTANT

Before operating your Brillion machine check all hardware for tightness.

After a few hours of initial use, check entire machine and tighten any loose nuts and bolts. Daily or periodic checks should be made thereafter



CAUTION

Escaping fluid under pressure can be nearly invisible and have enough force to penetrate the skin causing serious injury. Use a piece of cardboard, rather than hands, to search for suspected leaks. Wear protective gloves & safety glasses or goggles when working with hydraulic systems.

NOTE

Avoid the hazard by relieving pressure before disconnecting hydraulic lines. On most tractors this can be done by putting the valve controls in the float position before the engine is stopped.

Hose Set Up for Both Seeders on One Hydraulic Circuit

To control both seeders with one hydraulic circuit, remove the caps on the front seeder bulkhead tee.

1. With the hose still connected, remove the 90 degree Elbow fitting from the rear seeder straight bulkhead.
2. Connect the 90 degree elbow to the front seeder Tee bulkhead.
3. Reinstall previously removed caps to the straight bulkheads.
4. Tie up unused hydraulic hoses.

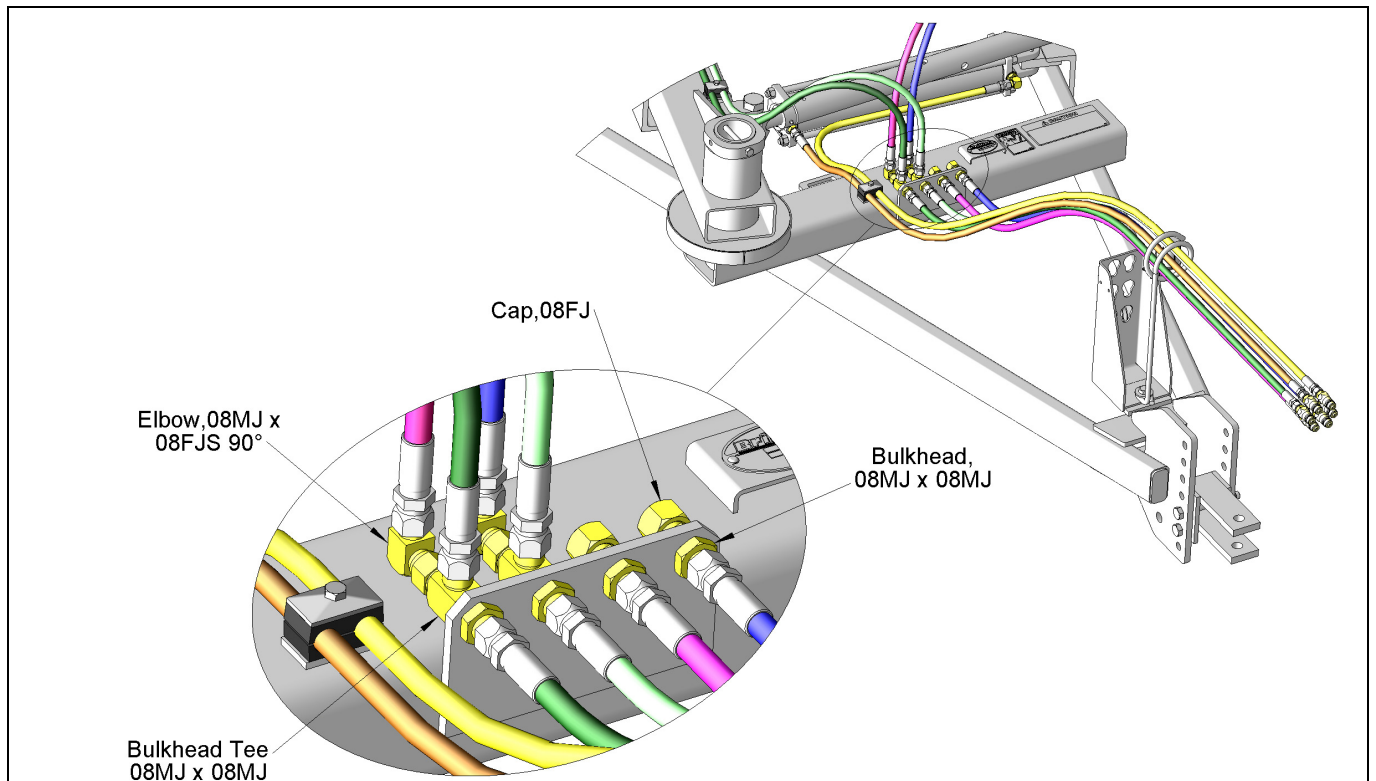

Figure 3-1: Hose Set Up for Both Seeders on One Hydraulic Circuit

Attaching the Seeders

NOTE

When attaching two seeders of different widths, attach the wider seeder always to the front hitch, and use the cylinder attaching holes specified for the wider seeder.

- With the Double Seeder Hitch in the transport position and the second seeder positioned as shown, drive as closely as possible to the hitch point of the second seeder.

- As soon as the front seeder is past the hitch of the second seeder, operate the hitch in the field position and turn the tractor to the right so that the rear hitch gets closer to the rear seeder.
- Disengage the pin from the rear hitch to allow the hitch plate to extend out and swing in either direction. Engage the pin on the rear hitch plate after attaching to the seeder.

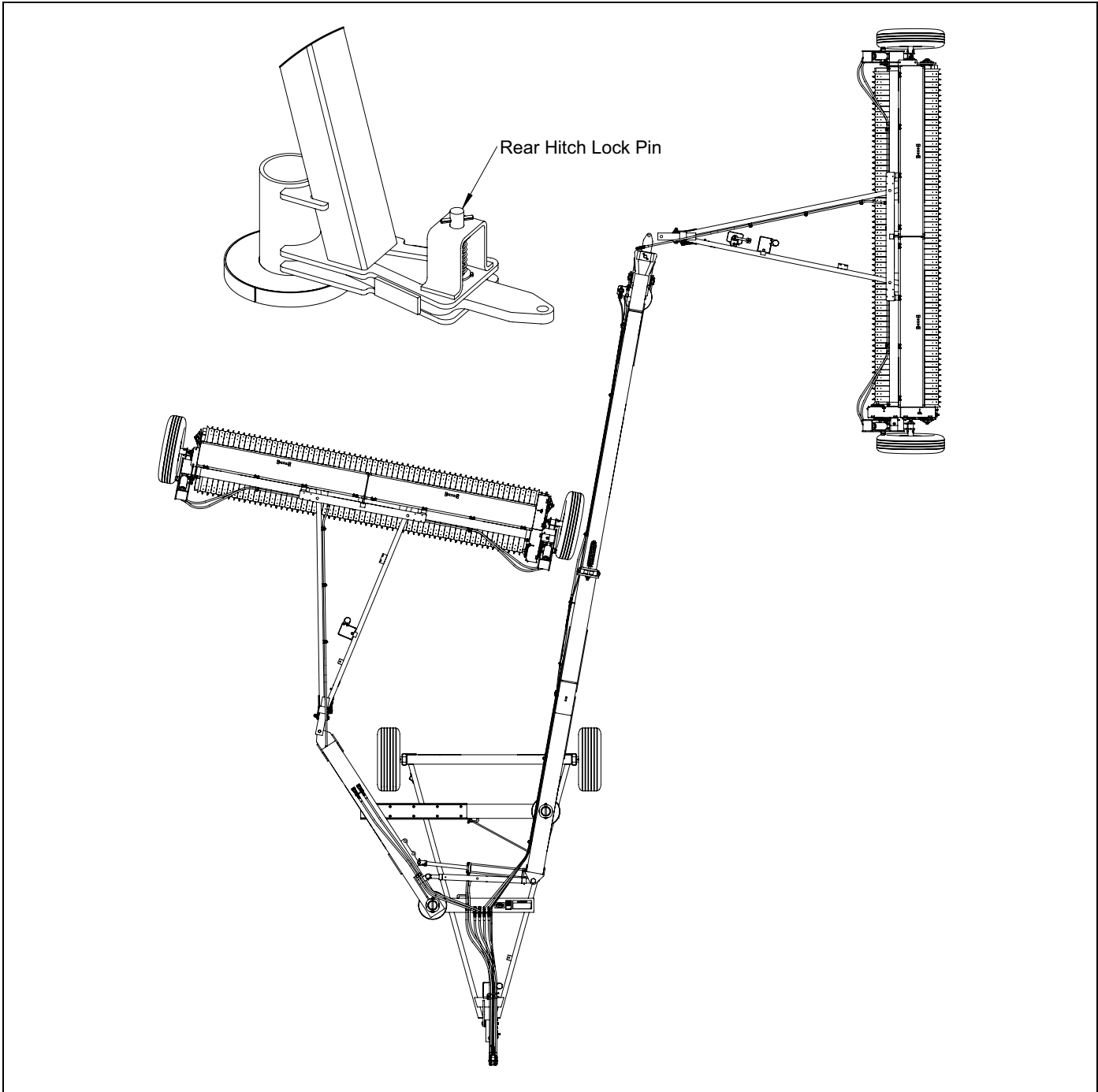

Figure 3-2: Attaching the Seeders

Transport Lock

Depending on the width of the seeders being used, install the Transport Lock as follows:

For Operation, remove the Hair Pin Cotter from the Transport Lock and rotate it and insert it into slot on the

Drawbar frame. Re-insert the Hair Pin Cotter.

For Transporting, retract the hydraulic cylinder. remove the hair Pin Cotter from the Transport Lock and rotate it and insert into the appropriate hole in the Short Hitch 3 hole Lug. Re-insert the Hair Pin Cotter.

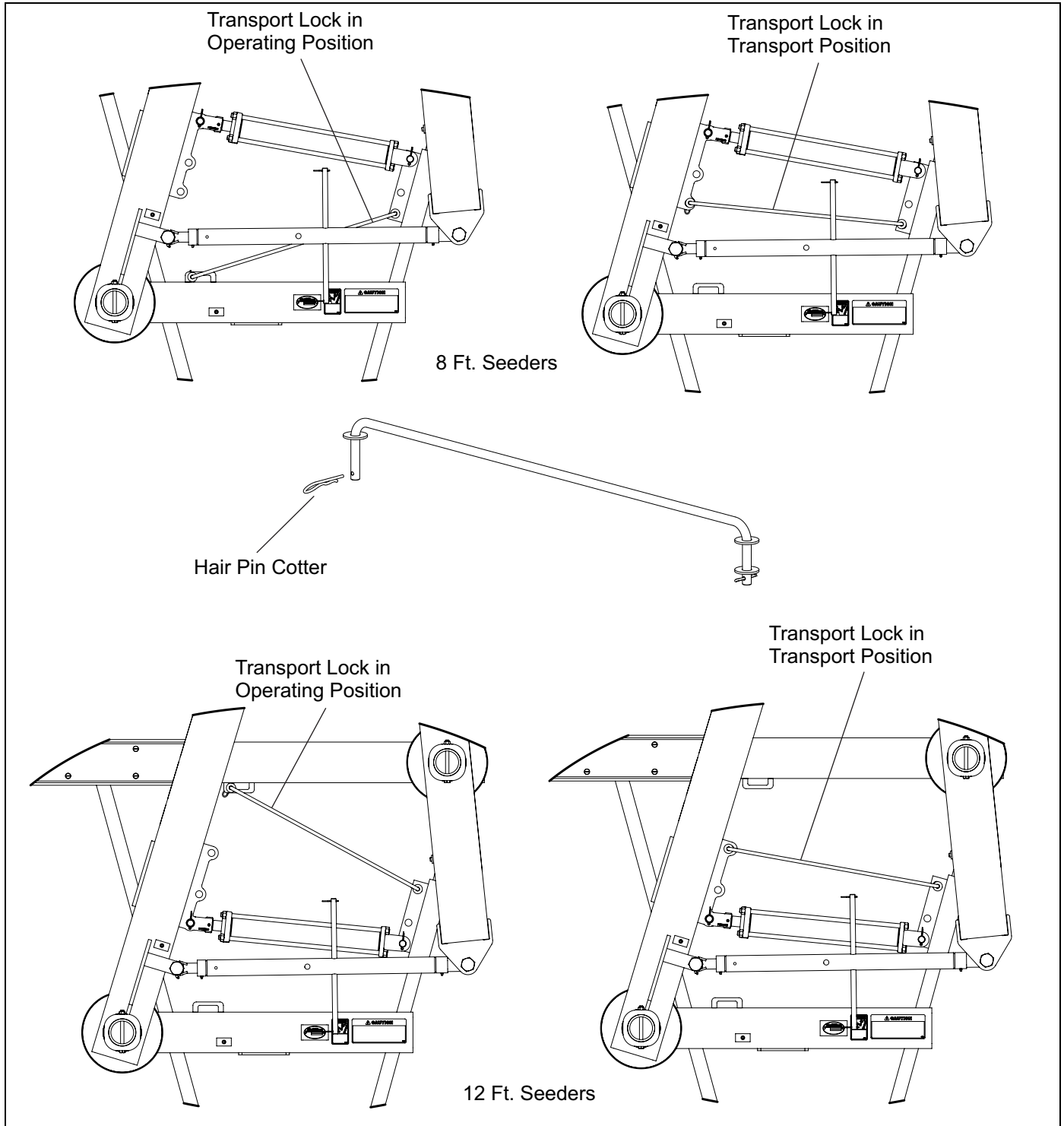

Figure 3-3: Transport Lock

Operating Position

- When making turns at the end of the field, the rear seeder must be raised, or it will cause the caster wheel to skid sideways.
- Use extreme caution when turning corners. When turning left, the seeder swings widely to the right.
- The left edge of the front seeder follows directly along the center of the tractor.

- The overlap of the seeders can be adjusted using the turnbuckle. Extending the turnbuckle increases the overlap.

NOTE

If more downward force is required on the rear hitch, increase the tension on the lower Spring Bolt nut.

When operating in fields with irregular contours, the position of the rear seeder can be adjusted by carefully adjusting the hydraulic cylinder stroke slightly.

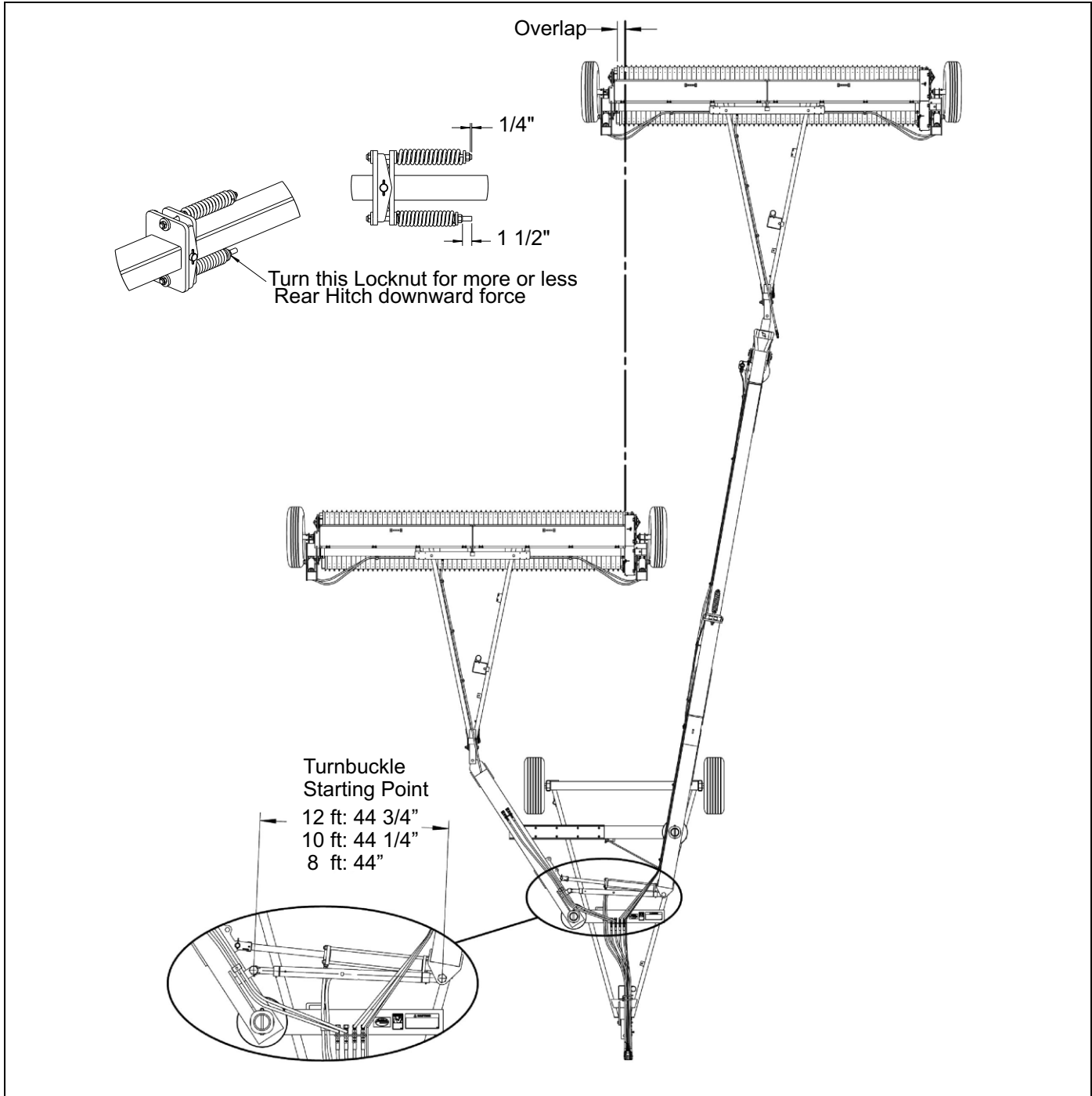

Figure 3-4: Operating Position

Transport Position



CAUTION

Use extreme caution when turning corners. When turning left, the rear seeder swings widely to the right.

- Retract the Hydraulic Cylinder to position the hitch into the Transport Position. Insert the Transport Lock into the correct set of holes prior to transport. See Figure 3-3.

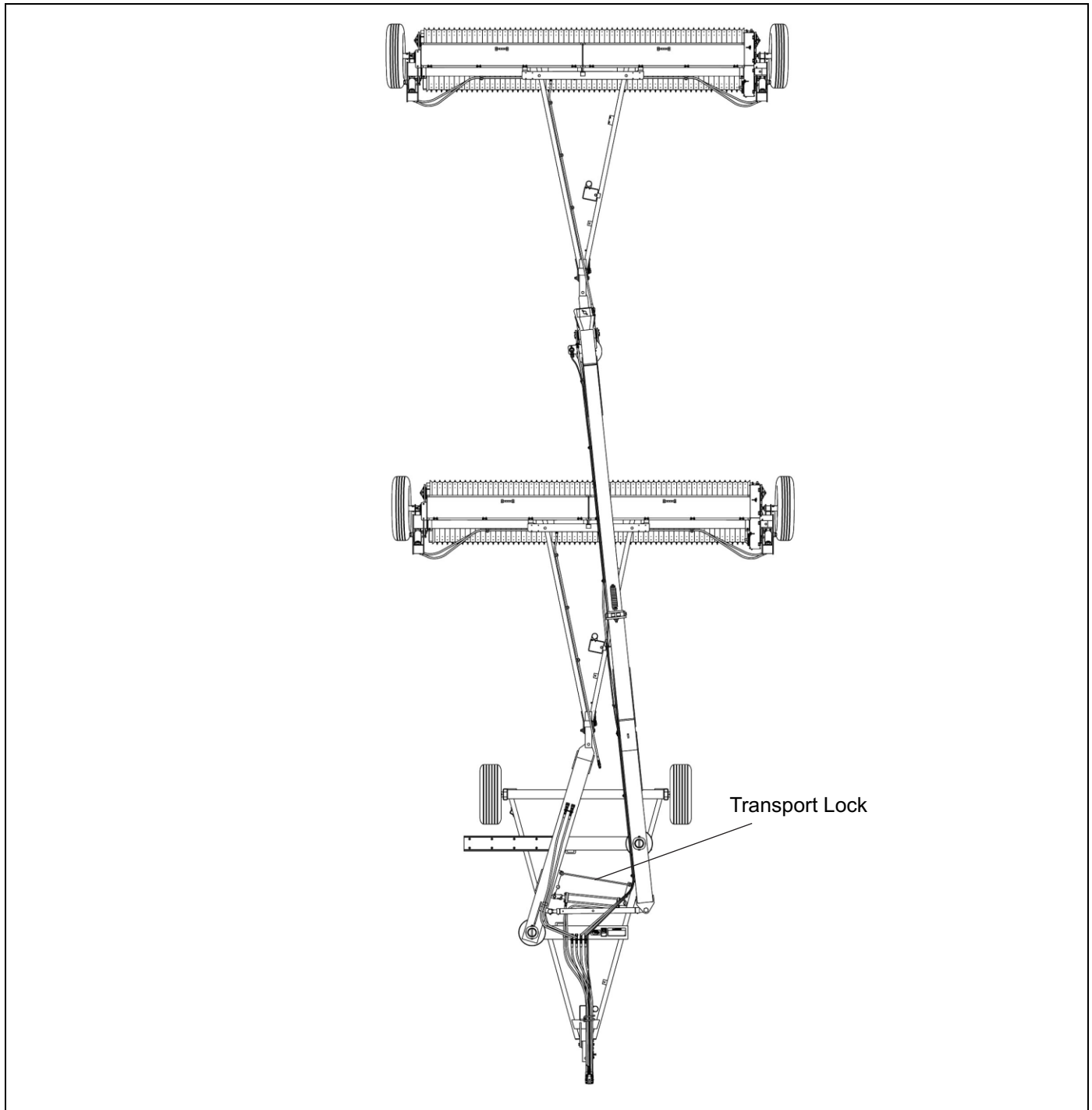

Figure 3-5: Transport Position

Storage

Clean your machine before storing at the end of season. Grease machine after washing to displace any residual water. Repaint areas where paint has worn off. Repair or replace any broken or damaged parts. Store in a dry, protected place.



CAUTION

Avoid spraying high pressure washer directly at bearing seals and electrical connections.

Fasteners

Before operating your Brillion machine, check all hardware for tightness. Use the Tightening Torque Table below as a guide.

After a few hours of use, check entire machine and tighten any loose nuts or bolts. Daily or periodic checks should be made thereafter.

When replacing bolts, be sure to use fasteners of equal grade.

General Torque Specifications (rev. 4/97)

This chart provides tightening torques for general purpose applications when special torques are not specified on process or drawing. Assembly torques apply to plated nuts and capscrews assembled without supplemental lubrication (as received condition). They do not apply if special graphite moly-disulfide or other extreme pressure lubricants are used. When fasteners are dry (solvent cleaned) add 33% to as received condition torque. Bolt head identification marks indicate grade and may vary from manufacturer to manufacturer. Thick nuts must be used on grade 8 capscrews. Use value in [] if using prevailing torque nuts

TORQUE SPECIFIED IN FOOT POUNDS

UNC SIZE	SAE Grade 2	SAE Grade 5	SAE Grade 8	UNF SIZE	SAE Grade 2	SAE Grade 5	SAE Grade 8
1/4-20	4 [5]	6 [7]	9 [11]	1/4-28	5 [6]	7 [9]	10 [12]
5/16-18	8 [10]	13 [13]	18 [22]	5/16-24	9 [11]	14 [17]	20 [25]
3/8-16	15 [19]	23 [29]	35 [42]	3/8-24	17 [21]	25 [31]	35 [44]
7/16-14	24 [30]	35 [43]	55 [62]	7/16-20	27 [34]	40 [50]	60 [75]
1/2-13	35 [43]	55 [62]	80 [100]	1/2-20	40 [50]	65 [81]	90 [112]
9/16-12	55 [62]	80 [100]	110 [137]	9/16-18	60 [75]	90 [112]	130 [162]
5/8-11	75 [94]	110 [137]	170 [212]	5/8-18	85 [106]	130 [162]	180 [225]
3/4-10	130 [162]	200 [250]	280 [350]	3/4-16	150 [188]	220 [275]	320 [400]
7/8-9	125 [156]	320 [400]	460 [575]	7/8-14	140 [175]	360 [450]	500 [625]
1-8	190 [237]	408 [506]	680 [850]	1-14	210 [263]	540 [675]	760 [950]
1-1/8-7	270 [337]	600 [750]	960 [1200]	1-1/8-12	300 [375]	660 [825]	1080 [1350]
1-1/4-7	380 [475]	840 [1050]	1426 [1782]	1-1/4-12	420 [525]	920 [1150]	1500 [1875]
1-3/8-6	490 [612]	1010 [1375]	1780 [2225]	1-3/8-12	560 [700]	1260 [1575]	2010 [2512]
1-1/2-6	650 [812]	1460 [1825]	2360 [2950]	1-1/2-12	730 [912]	1640 [2050]	2660 [3325]

MAINTENANCE

METRIC:

Coarse thread metric class 10.9 fasteners and class 10.0 nuts and through hardened flat washers, phosphate coated, Rockwell "C" 38-45. Use value in [] if using prevailing torque nuts

Nominal thread diameter (mm)	Newton Meters (Standard Torque)	Foot Pounds (Standard Torque)	Nominal Thread Diameter (mm)	Newton Meters (Standard Torque)	Foot Pounds (Standard Torque)
6	10 [14]	7 [10]	20	385 [450]	290 [335]
7	16 [22]	12 [16]	24	670 [775]	500 [625]
8	23 [32]	17 [24]	27	980 [1105]	730 [825]
10	46 [60]	34 [47]	30	1330 [1470]	990 [1090]
12	80 [125]	60 [75]	33	1790 [1950]	1340 [1450]
14	125 [155]	90 [115]	36	2325 [2515]	1730 [1870]
16	200 [240]	150 [180]	39	3010 [3210]	2240 [2380]
18	275 [330]	205 [245]			

Hydraulic Fitting Torque Specifications

37 degree JIC, ORS, &ORB (REV. 10/97)

This chart provides tightening torques for general purpose applications when special torques are not specified on process or drawing. Assembly torques apply to plated nuts and capscrews assembled without supplemental lubrication (as received condition). They do not apply if special graphite moly-disulfide or other extreme pressure lubricants are used. When fasteners are dry (solvent cleaned) add 33% to as received condition torque. Bolt head identification marks indicate grade and may vary from manufacturer to manufacturer. Thick nuts must be used on grade 8 capscrews. Use value in [] if using prevailing torque nuts

TORQUE SPECIFIED IN FOOT POUNDS

PARKER® BRAND FITTINGS

Dash Size	37 Deg. JIC	O-ring (ORS)	O-ring boss
-4	11-13	15-17	13-15
-5	14-16	-----	21-23
-6	20-22	34-36	25-29
-8	43-47	58-62	40-44
-10	55-65	100-110	58-62
-12	80-90	134-146	75-85
-16	115-125	202-218	109-121
-20	160-180	248-272	213-237
-24	185-215	303-327	238-262
-32	250-290	-----	310-340

AEROQUIP® BRAND FITTINGS

Dash Size	37 Deg. JIC	O-ring (ORS)	O-ring boss
-4	11-12	10-12	14-16
-5	15-16	-----	16-20
-6	18-20	18-20	24-26
-8	38-42	32-35	50-60
-10	57-62	46-50	75-80
-12	79-87	65-70	125-135
-14	-----	-----	160-180
-16	108-113	92-100	200-220
-20	127-133	125-140	210-280
-24	158-167	150-165	270-360

GATES® BRAND FITTINGS

Dash Size	37 Deg. JIC	O-ring (ORS)	O-ring boss
-4	10-11	10-12	14-16
-5	13-15	-----	-----
-6	17-19	18-20	24-26
-8	34-38	32-40	37-44
-10	50-56	46-56	50-60
-12	70-78	65-80	75-83
-14	-----	65-80	-----
-16	94-104	92-105	111-125
-20	124-138	125-140	133-152
-24	156-173	150-180	156-184
-32	219-243	-----	-----

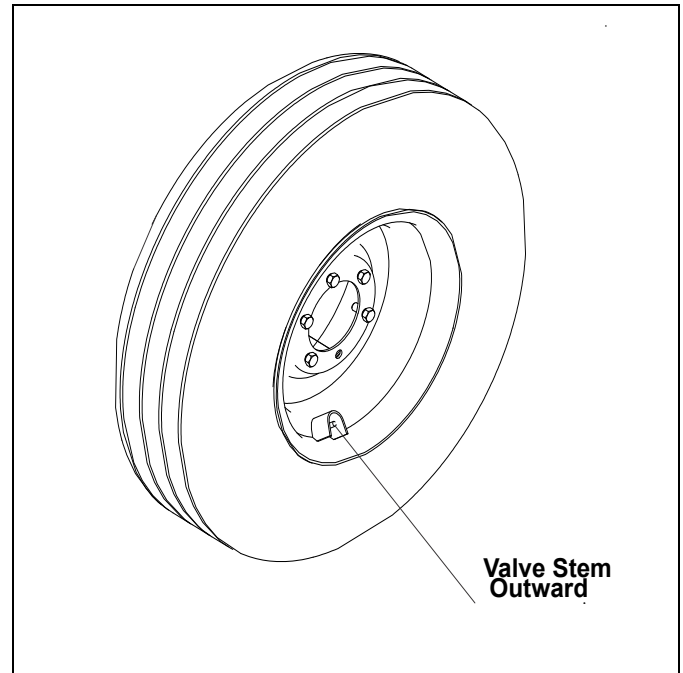

Figure 4-1 Tires

Tires

! WARNING

Use of smaller or lighter tires will cause premature tire failure and may cause an accident.

Recommended inflation pressure is as follows:

27 x 9.50 - 15 NHS-10 Ply Tire: maximum pressure is 65 PSI.

20.5 x 8 - 10 Caster Wheel Tire: maximum pressure is 35 PSI.

After several hours of use re-torque Wheel Bolts to 80-85 Ft-lbs.

Hydraulic System

! WARNING

Escaping fluid under pressure can be nearly invisible and have enough force to penetrate the skin causing serious injury. Use a piece of cardboard, rather than hands to search for suspected leaks. Wear protective gloves and safety glasses or goggles when working with hydraulic system.

Check the hydraulic lines and cylinders for leaks before starting operation each day.

When the machine is not to be used for some time, exposed portions of the cylinder rods should be cleaned and covered with a thin coat of grease. This will prevent corrosion which will damage the cylinder seals.

Lubrication

Lubricate bearings with quality grease per recommended lubrication frequency intervals indicated or if machine is not used for an extended period. Greaseable components are the same on each side.

CAUTION

Over lubrication of these bearings can cause premature bearing failure.

It is good machine maintenance practice to check all bolts for tightness during regular lubrications. Tighten any fasteners that may have loosened during operation.

Lubricating Wheel Hub:

Grease Wheel Hubs every 50 hours of operation or annually.

Repack Wheel Hub bearings annually before each season usage. See Figure 4-2.

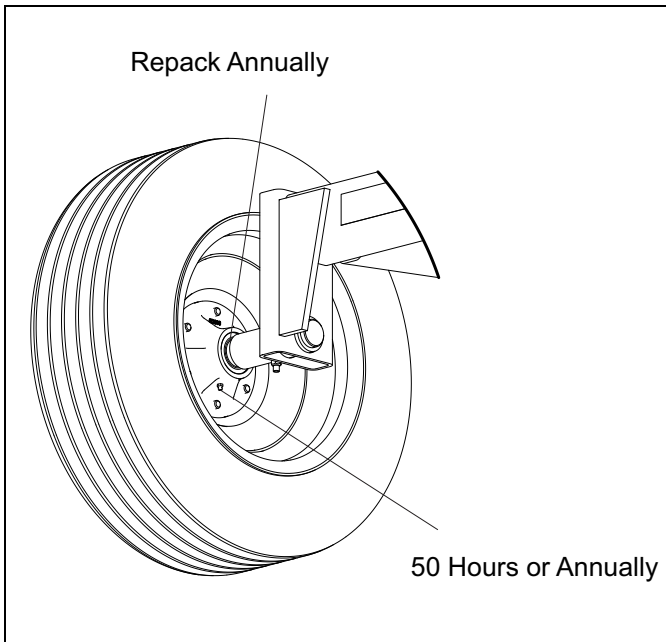

Figure 4-2 Lubricating Wheel Hub

Lubricating Turnbuckle:

Lubricate the four Turnbuckle Grease Fittings every 20 hours of operation. See Figure 4-3.

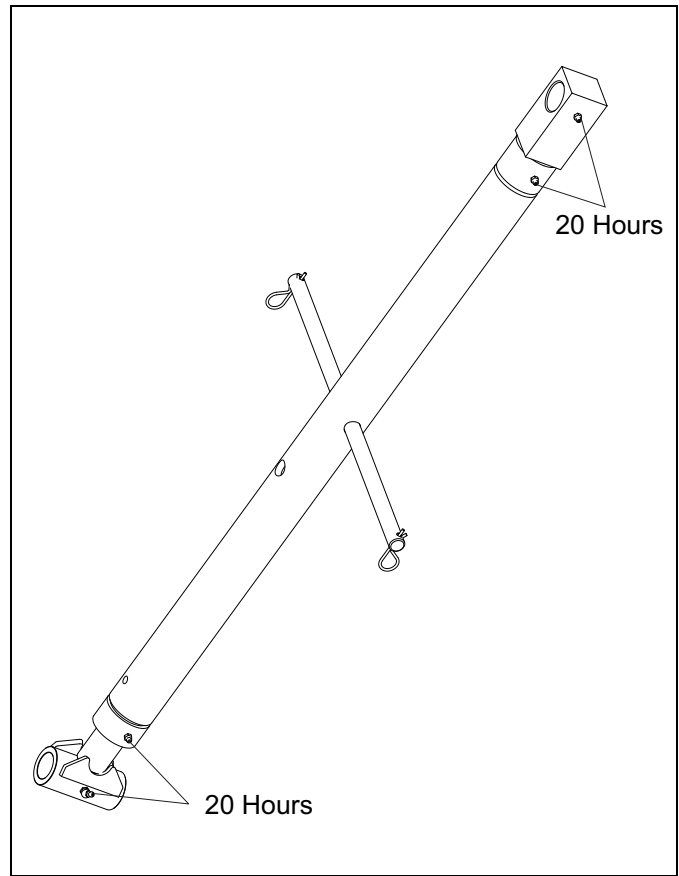

Figure 4-3 Turnbuckle

Document Control Revision Log:

Date	Revision	Improvement(s) Description and Comments
04/2012		Initial Release



Intertek

Equipment from Landoll Corporation is built to exacting standards ensured by ISO 9001 registration at all Landoll manufacturing facilities.

Double Seeder Hitch BDH512 Operator's Manual

Re-Order Part Number F-645-R1

LANDOLL CORPORATION

1900 North Street

Marysville, Kansas 66508

(785) 562-5381

800-428-5655 ~ WWW.LANDOLL.COM



Copyright 2012. Landoll Corporation

"All rights reserved, including the right to reproduce this material or portions thereof in any form."