



# ML RIGID PULVI-MULCHER

Models: 2253

ML, MLS, MCL, MLC, MCC,  
MCLS, MLCS and MCCS

## Parts Manual

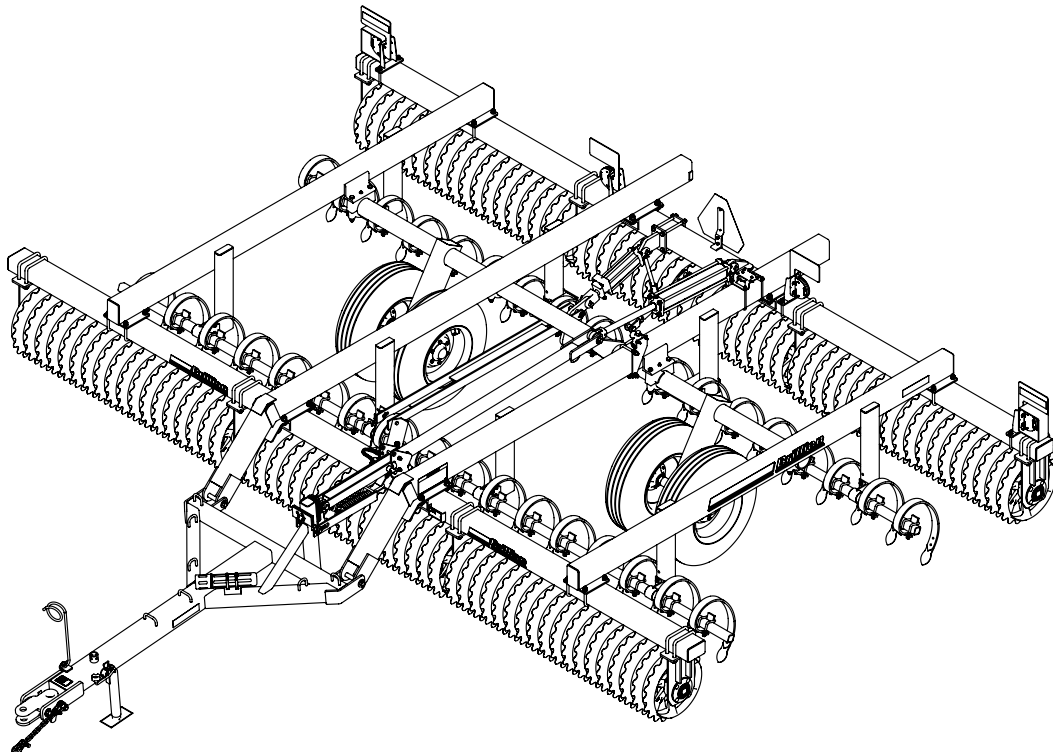

**LANDOLL COMPANY, LLC**

1900 North Street

Marysville, Kansas 66508

(785) 562-5381

800-428-5655 ~ [WWW.LANDOLL.COM](http://WWW.LANDOLL.COM)

---

## Manuals for ML2253 Pulvi-Mulcher

Manual Number	Manual Type
1K965	Operator's Manual
1K975	Parts Manual

# Table of Contents

## 1 Illustrated Parts List

Instructions for Ordering Parts	1-1
Frame	1-2
Drawbar (After 07/2016)	1-4
Drawbar (Before 07/2016)	1-6
Drawbar Assembly	1-8
Rockshaft and Wheels	1-10
Rockshaft Assembly	1-12
Hub and Spindle Assembly	1-13
Wheel Assembly	1-14
Independent Tooth Control, C-Tooth	1-16
Independent Tooth Control, S-Tine	1-18
Tooth Control, C-Tooth	1-20
Tooth Control, S-Tine	1-22
Roller	1-24
Center Bracket Assembly	1-26
End Bracket Assembly	1-27
Wheel and Axle Assemblies, Notched	1-28
Wheel and Axle Assemblies, Notched with Replaceable Stub	1-29
Wheel and Axle Assembly, Crowfoot	1-30
Wheel and Axle Assembly, Crowfoot With Replaceable Stub	1-31
Axle Clamp Assembly	1-32
Pipe Axle Assembly	1-34
Pipe Axle Assembly With Replaceable Stub	1-35
Flange Stub Assembly	1-36
Stub Assembly	1-37
Hydraulic Diagram (Before 03/01/2003)	1-38
Hydraulic Diagram	1-40
Hydraulic Diagram, Tooth Control	1-41
LED Lights Layout (After 01/01/2017)	1-42
Lights (Before 01/01/2017)	1-44
Scrape Kit, Optional Front and Standard on Rear	1-45
Rear Hitch - Optional	1-46
Land Leveler - Optional	1-47
V-Leveler Kit - Optional	1-48
Hydraulic Cylinder, 3-1/2 x 16 (Before 08/01/1997) - Hydraulic Gear	1-49
Hydraulic Cylinder, 3-1/2 x 16 (Before 08/01/1997) - Lion	1-50
Hydraulic Cylinder, 3-1/2 x 16 (Before 08/01/2000)	1-51
Hydraulic Cylinder, 3-1/2 x 16 (Used 08/01/2000 to 01/15/2008)	1-52
Hydraulic Cylinder, 3-1/2 x 16 (After 01/15/2008)	1-53
Hydraulic Cylinder, 3 x 8 - Cross	1-54
Hydraulic Cylinder, 3 x 8 - Prince	1-56
Decals	1-58

## 2 Glossary

## 3 Index



# Illustrated Parts List

## Instructions for Ordering Parts

**\*\* Repair parts must be ordered through an authorized dealer \*\***

### DEALER INSTRUCTIONS FOR ORDERING PARTS FROM LANDOLL PARTS DISTRIBUTION CENTER

PHONE #: 800-423-4320 OR 785-562-5381

FAX #: 888-527-3909

ORDER ONLINE: [Dealer.landoll.com](http://Dealer.landoll.com)

### IDENTIFICATION PLATE

See Figure 1-1 for the Identification Plate, which lists the model and serial number of the equipment. It is located on the left side of the Rigid Pulvi-Mulcher.

### SERIAL NUMBER NOMENCLATURE

The serial number for the Rigid Pulvi-Mulcher is located on the identification plate. The following information will help decode the Landoll serial number.

**PMD20000100=xxmyysss**

<b>xx</b>	= model series (i.e. "PM" for all Pulvi-Mulchers)
<b>m</b>	= month of manufacture (ex. "D" means April. The letter I is not used.)
<b>yy</b>	= last digits of the year manufactured (ex. "20" means 2020)
<b>sss</b>	= Sequential number used to track warranty and service information.

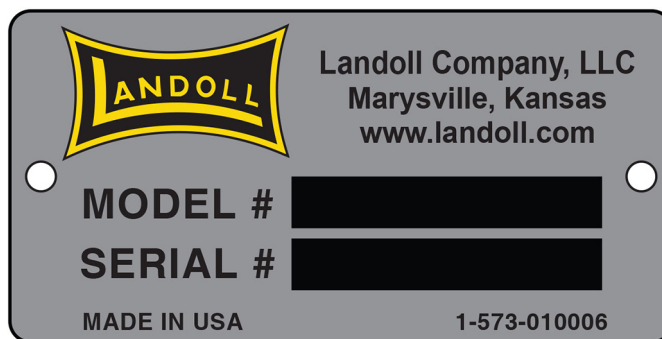

Figure 1-1: Identification Plate

# Frame

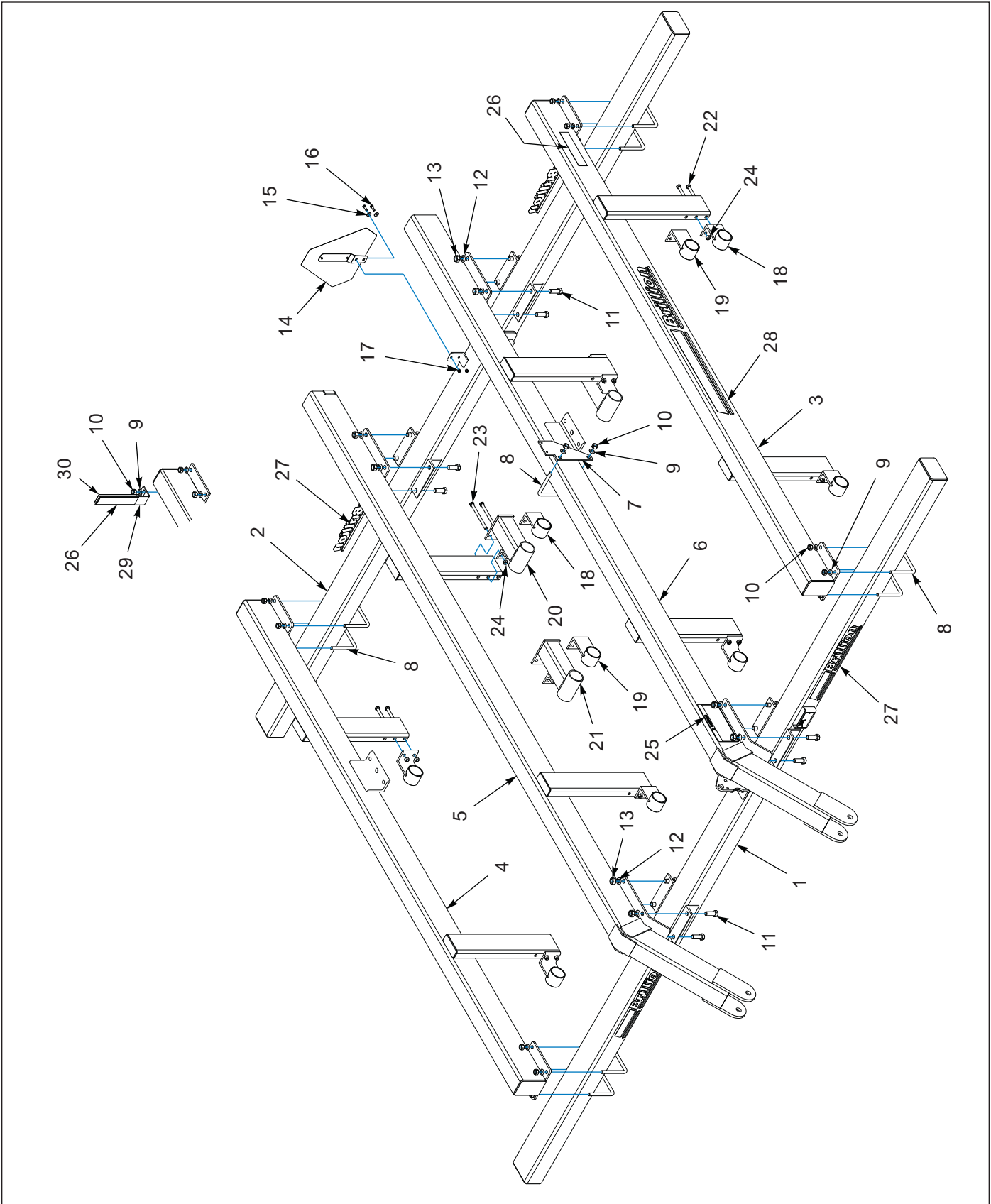

Figure 1-2: Frame

## Frame

ITEM	PART NUMBER	DESCRIPTION	QTY
1	1K951	FRONT TUBE	1
2	1K952	REAR TUBE	1
3	9J103	LH OUTER FRAME TUBE	1
4	9J104	RH OUTER FRAME TUBE	1
5	1K041	R.H. INNER FRAME TUBE	1
6	1K040	L.H. INNER FRAME TUBE	1
7	9J187	BRACKET	1
8	7J990	U-BOLT, 5/8-11 X 5-1/2 X 6-11/16	9
9	1-861-010034-15	WASHER, LKG, HLCL SPR, 5/8	18
10	1-512-010007-11	NUT, HEX 5/8-11, ZP	18
11	1-654-010061-05	SCREW, HEX CAP 3/4-10UNC X 2, GR5, ZP	16
12	1-861-010034-17	WASHER, LKG, HLCL SPR, 3/4	16
13	1-512-010007-12	NUT HEX 3/4-10, ZP	16
14	2P151	SMV W/BRACKET	1
15	1-861-010032-09	WASHER, FL 5/16 STD, ZP	2
16	1-654-010049-05	HHCS, 5/16-18 X 1 GR5, ZP	2
17	104032	NUT NY-LOCK 5/16-18 ZP	2
18	9J090	BRACKET, C-TOOTH	6
19	9J091	BRACKET, S-TINE	6
20	3K074	BRACKET, C-TOOTH	2
21	3K073	BRACKET, S-TINE	2
22	1-654-010055-17	SCREW, HEX CAP 1/2-13UNC X 6, GR5	12
23	1-654-010055-18	SCREW, HX CAP 1/2-13UNC X 6-1/2, G5	4
24	1-512-010005-09	NUT, HEX SLFLKG, 1/2-13 GRB	16
25	8J309	DECAL, CAUTION	1
26	528934	REFLECTOR - YELLOW	4
27	4K036	DECAL, BRILLION (2 3/4 X 20)	4
28	4K039	DECAL, BRILLION (3 1/2 X 40)	2
29	1K089	DECAL BRACKET (BEFORE 01/2017)	2
30	528933	REFLECTOR - RED	2

Drawbar (After 07/2016)

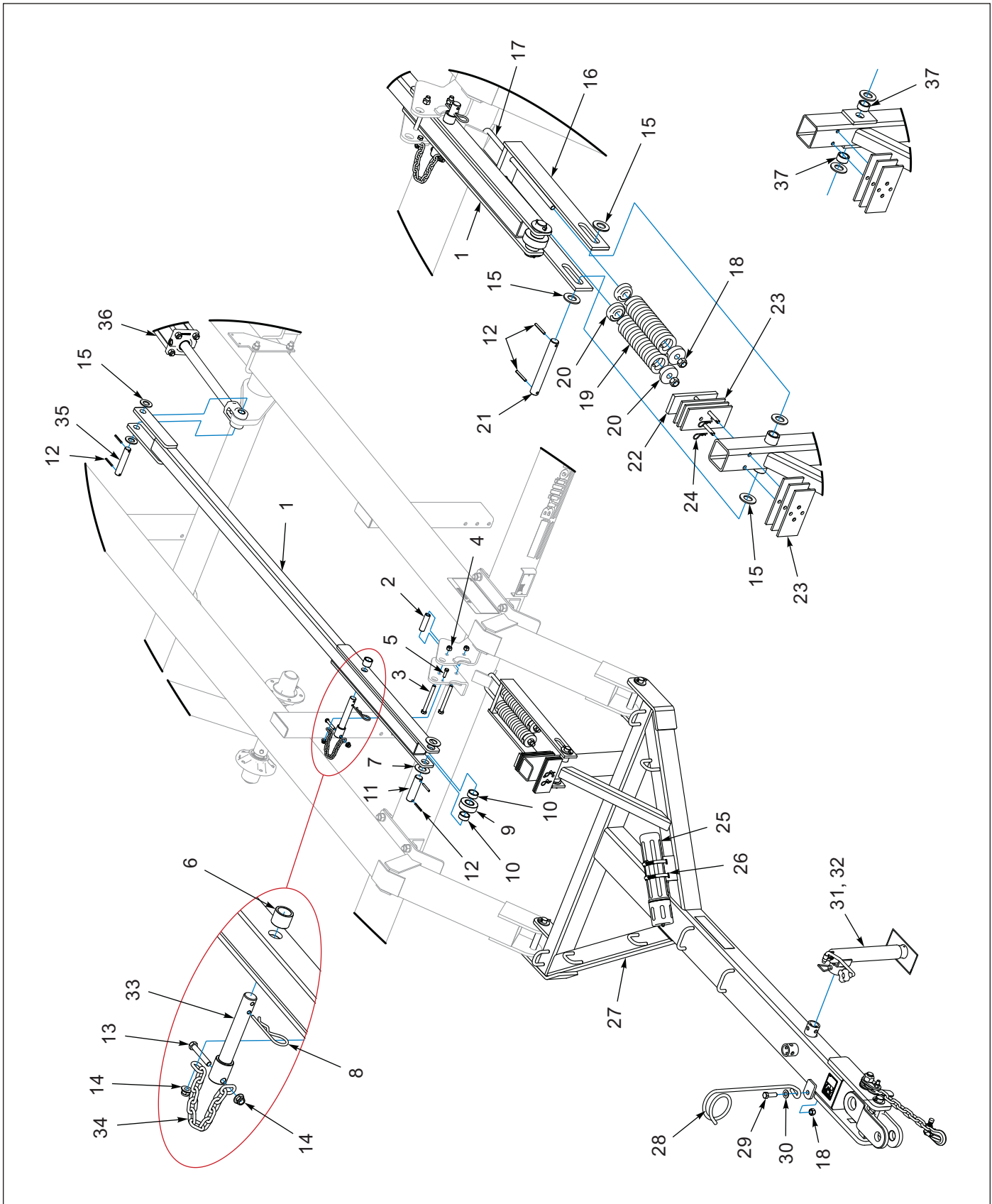

Figure 1-3: Drawbar (After 07/2016)



## Drawbar (After 07/2016)

ITEM	PART NUMBER	DESCRIPTION	QTY
1	201436	LINK, TRANSPORT AXLE	1
2	8J118	SPACER <b>(0.546 X 0.84 X 3.0)</b>	1
3	1-654-010055-15	SCR, HX CP, 1/2-13UNC X 5, GR5	2
4	1-512-010005-09	NUT, HEX SLFLKG, 1/2-13, GRB	2
5	1-654-010051-06	SCREW, HEX CAP 3/8-16UNC X 1-1/4	1
6	9J278	SPACER <b>(1.031 X 1.375 X 1.063)</b>	1
7	196120	WASHER, THRUST SS 1-1/4 12 GA	2
8	1D594	HAIR PIN COTTER .78 X 3-9/16	1
9	3J512	ROLLER ASSEMBLY	1
10	8J085	SPACER <b>(1.375 X 1.66 X 0.688)</b>	2
11	2P071	PIN, 1.25 X 4.5	1
12	1-647-010004221	ROLL PIN 1/4 X 2 PLATED	6
13	1-654-010051-10	SCREW, HX CP 3/8-16 X 2-1/4, GR5	1
14	2P252	NUT, FLANGE LOCK 3/8-16	2
15	1-861-010032-24	WASHER FL 1IN NARROW, ZP	6
16	8J104	SPRING LINKAGE	1
17	8J163	U-BOLT, 5/8-11 X 16 X 2-3/4, ZP	1
18	1-512-010005-13	NUT, LOCK 5/8-11 GRB ZP	3
19	6J460	COMPRESSION SPRING	2
20	6J459	CAP <b>(PAINTED BLACK)</b>	4
21	6J045	CYLINDER PIN <b>(1.0 X 7.5 H2)</b>	1
22	8J113	BUMPER	1
23	8J903	SPACER	6
24	6C400	HAIR PIN COTTER	2
25	1-116-010019	MANUAL STORAGE CANISTER	1
26	105-0093	HOSE CLAMP 4-1/2 IDEAL #5264	2
27	1K188	DRAWBAR ASSEMBLY <b>(SEE FIGURE 1-5)</b>	1
28	6D333	HOSE SUPPORT	1
29	1-654-010059-05	BOLT, 5/8-11 X 2 GR5, ZP	1
30	1-861-010032-18	WASHER FL 5/8 SAE, ZP	1
31	3J880	DRAWBAR JACK	1
32	6K458	9/16 JACK PIN W/CHAIN & SCREW	1
33	201439	PIN, TRANSPORT LINK	1
34	201440	CHAIN, 3/16 PROOF 12 LINKS	1
35	5J571	PIN <b>(1 X 5-1/16)</b>	1
36	6K843	HYD CYLINDER - 3 1/2 X 16 <b>(SEE FIGURE 1-38)</b>	2
37	8J212	SPACER <b>(1.031 X 1.375 X 0.688) (BEFORE 01/2017)</b>	2

Drawbar (Before 07/2016)

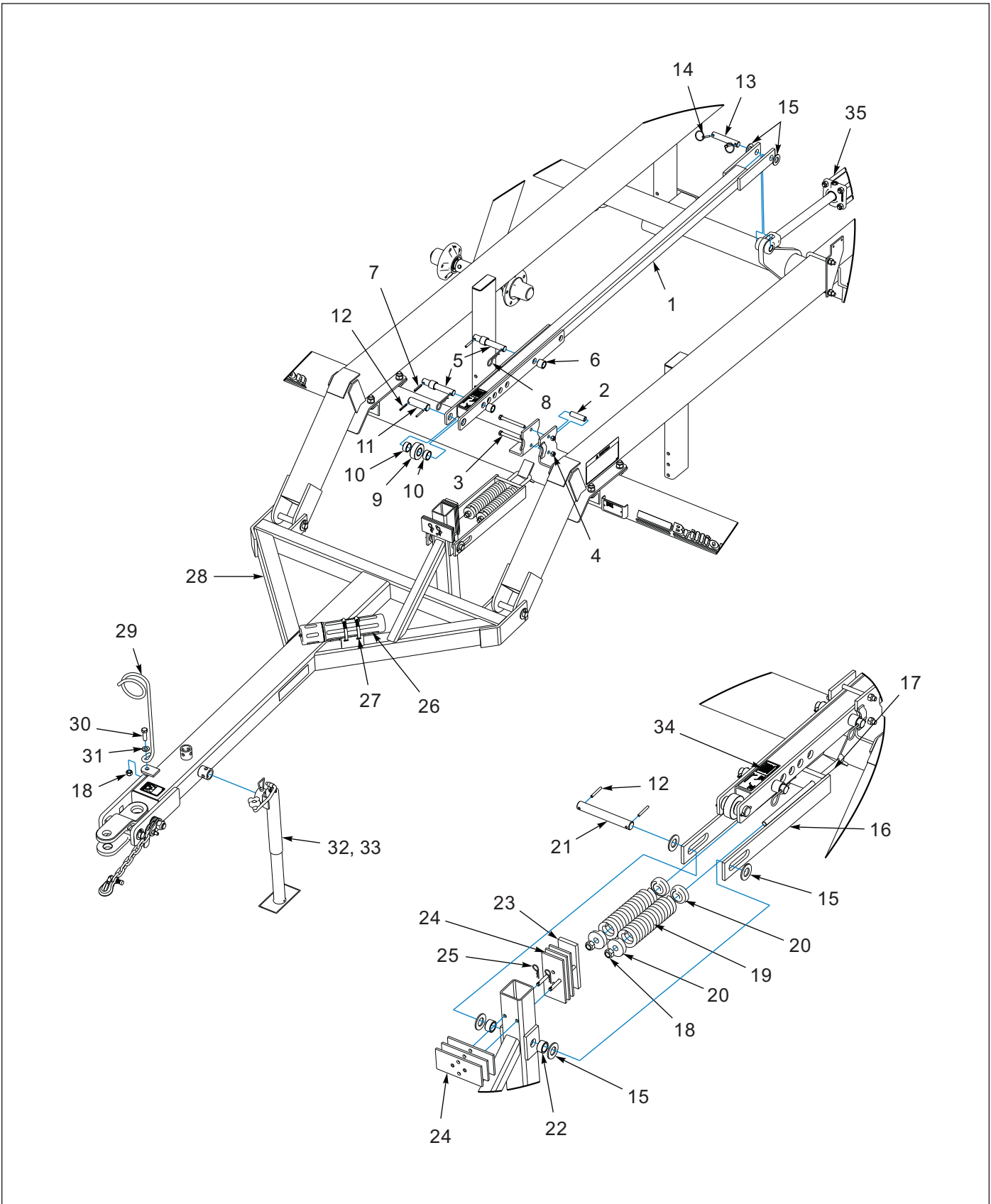

Figure 1-4: Drawbar (Before 07/2016)

## Drawbar (Before 07/2016)

ITEM	PART NUMBER	DESCRIPTION	QTY
1	8J083	LINK	1
2	8J118	SPACER (0.546 X 0.84 X 3.0)	1
3	1-654-010055-15	SCR, HX CP, 1/2-13UNC X 5, GR5	2
4	1-512-010005-09	NUT, HEX SLFLKG, 1/2-13 GRB	2
5	6J580	PIN (1.0 X 6.5 H2)	2
6	9J278	SPACER (1.031 X 1.375 X 1.063)	4
7	147072	ROLL PIN 5/16 X 2"	2
8	1D594	HAIR PIN COTTER .78 X 3-9/16	2
9	3J512	ROLLER ASSEMBLY	1
10	8J085	SPACER (1.375 X 1.66 X 0.688)	2
11	4J549	HINGE PIN (1.25 X 4.0 H2)	1
12	1-647-010004221	ROLL PIN 1/4 X 2 PLATED	4
13	5J768	PIN (1.0 X 5.50 H2)	1
14	1-557-010327	KLIK PIN 1/4 X 1-1/4	2
15	1-861-010032-24	WASHER FL 1IN NARROW, ZP	6
16	8J104	SPRING LINKAGE	1
17	8J163	U-BOLT 5/8-11 X 16 X 2-3/4, ZP	1
18	1-512-010005-13	NUT LOCK 5/8-11 GRB ZP	3
19	6J460	COMPRESSION SPRING	2
20	6J459	CAP (PAINTED BLACK)	4
21	6J045	CYLINDER PIN (1.0 X 7.5 H2)	1
22	8J212	SPACER (1.031 X 1.375 X 0.688)	2
23	8J113	BUMPER	1
24	8J903	SPACER	6
25	6C400	HAIR PIN COTTER	2
26	1-116-010019	MANUAL STORAGE CANISTER	1
27	105-0093	HOSE CLAMP 4-1/2 IDEAL #5264	2
28	1K188	DRAWBAR ASSEMBLY (SEE FIGURE 1-4)	1
29	6D333	HOSE SUPPORT	1
30	1-654-010059-05	BOLT, 5/8-11 X 2 GR5, ZP	1
31	1-861-010032-18	WASHER, FL 5/8 SAE, ZP	1
32	3J880	DRAWBAR JACK	1
33	6K458	9/16 JACK PIN W/CHAIN & SCREW	1
34	9J257	"IMPORTANT" DECAL	1
35	6K843	HYD CYLINDER - 3 1/2 X 16 (SEE FIGURE 1-38)	2

# Drawbar Assembly

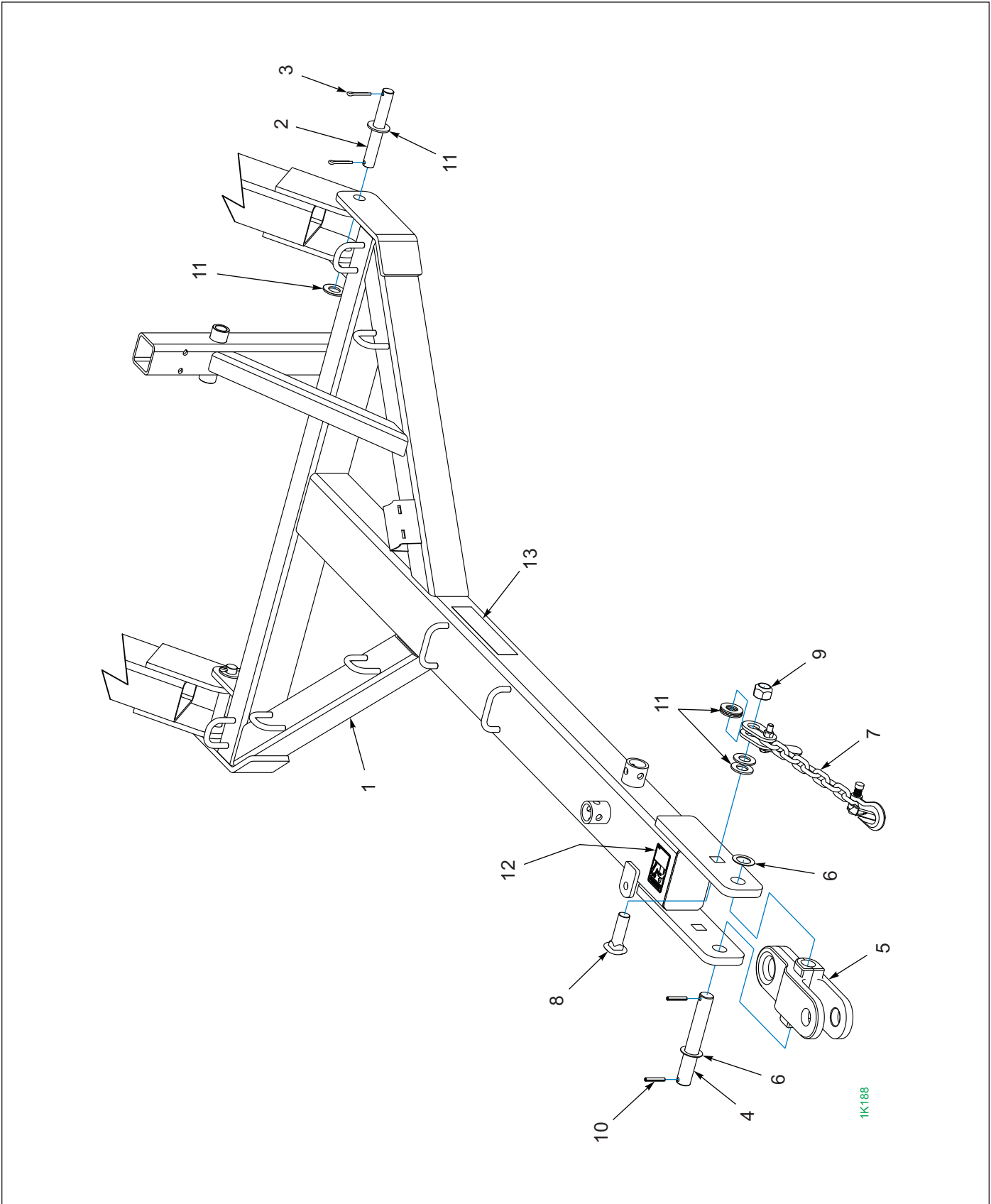

Figure 1-5: Drawbar Assembly

## Drawbar Assembly

ITEM	PART NUMBER	DESCRIPTION	QTY
	1K188	DRAWBAR ASSEMBLY	1
1	1K181	DRAWBAR	1
2	4D100	DRAWBAR MOUNTING PIN (1.0 X 7.438 H2)	2
3	4C446	COTTER PIN (1/4 X 1-1/2, ZP)	4
4	3J496	PIN (1.25 X 8.75 H2)	1
5	2J858	HITCH	1
6	8D857	WASHER SPECIAL (1.281 X 2.0 X 16GA)	2
7	141434	SAFETY CHAIN 21,000LB	1
8	151508	SCREW, HX CP 1-8UNC X 3-1/2, GR5 (BEFORE 07/15/2011)	1
8	169561	SCREW, RD HD, SQ NCK1-8 X 3-1/4, GR5 (AFTER 07/15/2011)	1
9	1-512-010005-19	NUT 1-8 HEX SLF-LOCKING GRB	1
10	147072	ROLL PIN 5/16 X 2	2
11	1-861-010032-24	WASHER, FL 1 IN NARROW, ZP	9
12	3K706	DECAL-WARNING HYDRAULIC LEAKS	1
13	528934	REFLECTOR - YELLOW	2

# Rockshaft and Wheels

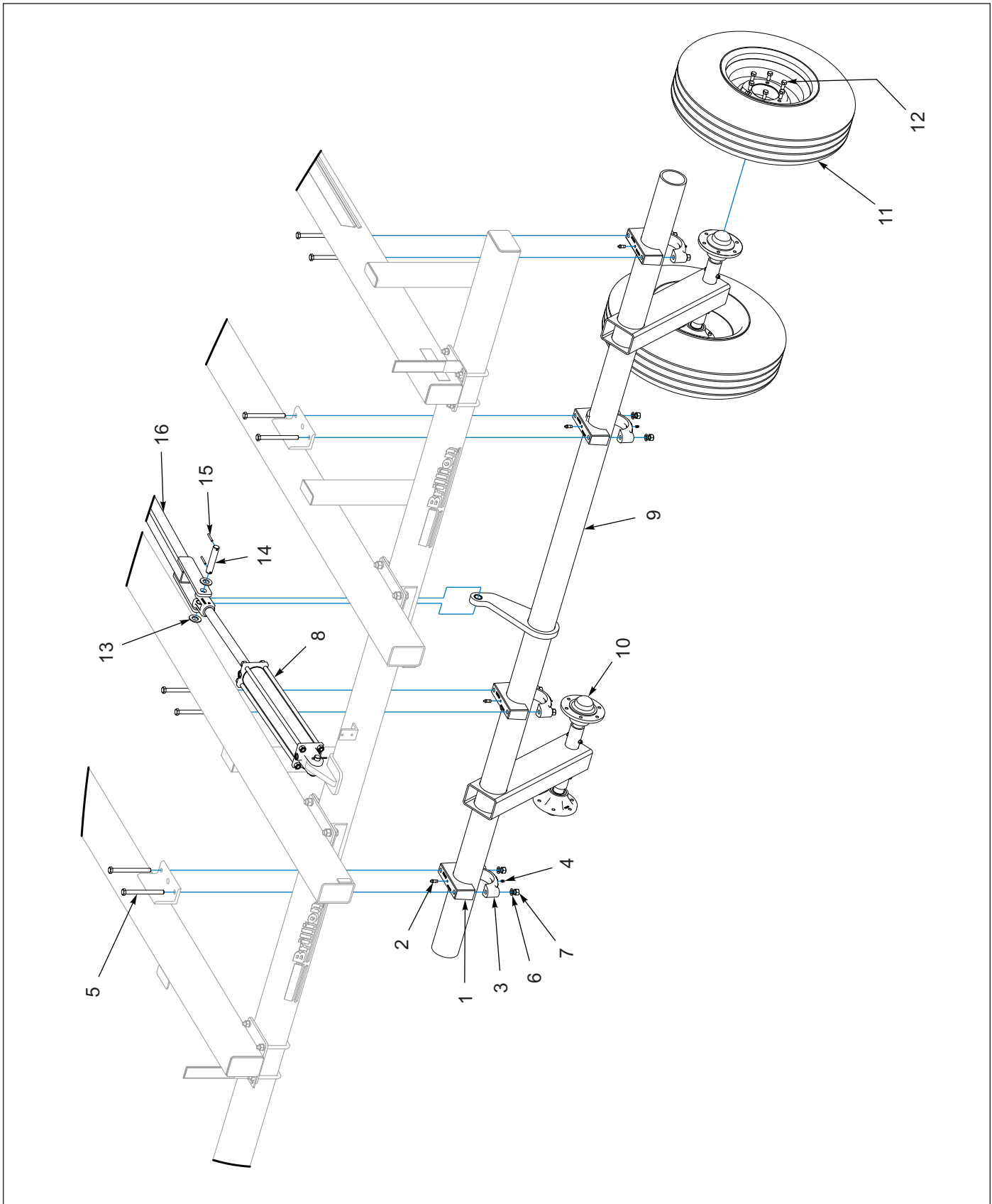

Figure 1-6: Rockshaft and Wheels

## Rockshaft and Wheels

ITEM	PART NUMBER	DESCRIPTION	QTY
1	9D653	AXLE BEARING ASSEMBLY (809D654) <b>(INCLUDES ITEM 2)</b>	4
2	2C643	GREASE FITTING <b>(1/8PTF X 1.25)</b>	1
3	6D309	AXLE TOP BEARING ASSEMBLY <b>(INCLUDES ITEM 4)</b>	4
4	1C023	FITTING, GREASE <b>(3/8 DRIVE)</b>	1
4	1-298-010001-1	ZERK FITTING 1/4 SAE	1
5	113064	SCREW, HX CP, 5/8-11UNC X 7, GR5	8
6	1-861-010034-15	WASHER, LKG, HLCL SPR, 5/8	8
7	1-512-010007-11	NUT, HEX 5/8-11, ZP	8
8	6K843	HYD CYLINDER - 3 1/2 X 16 <b>(SEE FIGURE 1-38)</b>	2
9	1K953	ROCK SHAFT <b>(SEE FIGURE 1-7)</b>	1
10	1J398	HUB & SPINDLE ASSEMBLY <b>(SEE FIGURE 1-8)</b>	4
11	6K926	WHEEL 8J790/NO TUBE/6J189 <b>(SEE FIGURE 1-9)</b>	4
12	5C100	WHEEL BOLT 1/2-20 X 1 GR5, ZP	20
13	1-861-010032-24	WASHER FL 1IN NARROW, ZP	2
14	5J571	PIN <b>(1 X 5-1/16)</b>	1
15	1-647-010004221	ROLL PIN 1/4 X 2 PLATED	2
16	201436	LINK, TRANSPORT AXLE	1

# Rockshaft Assembly

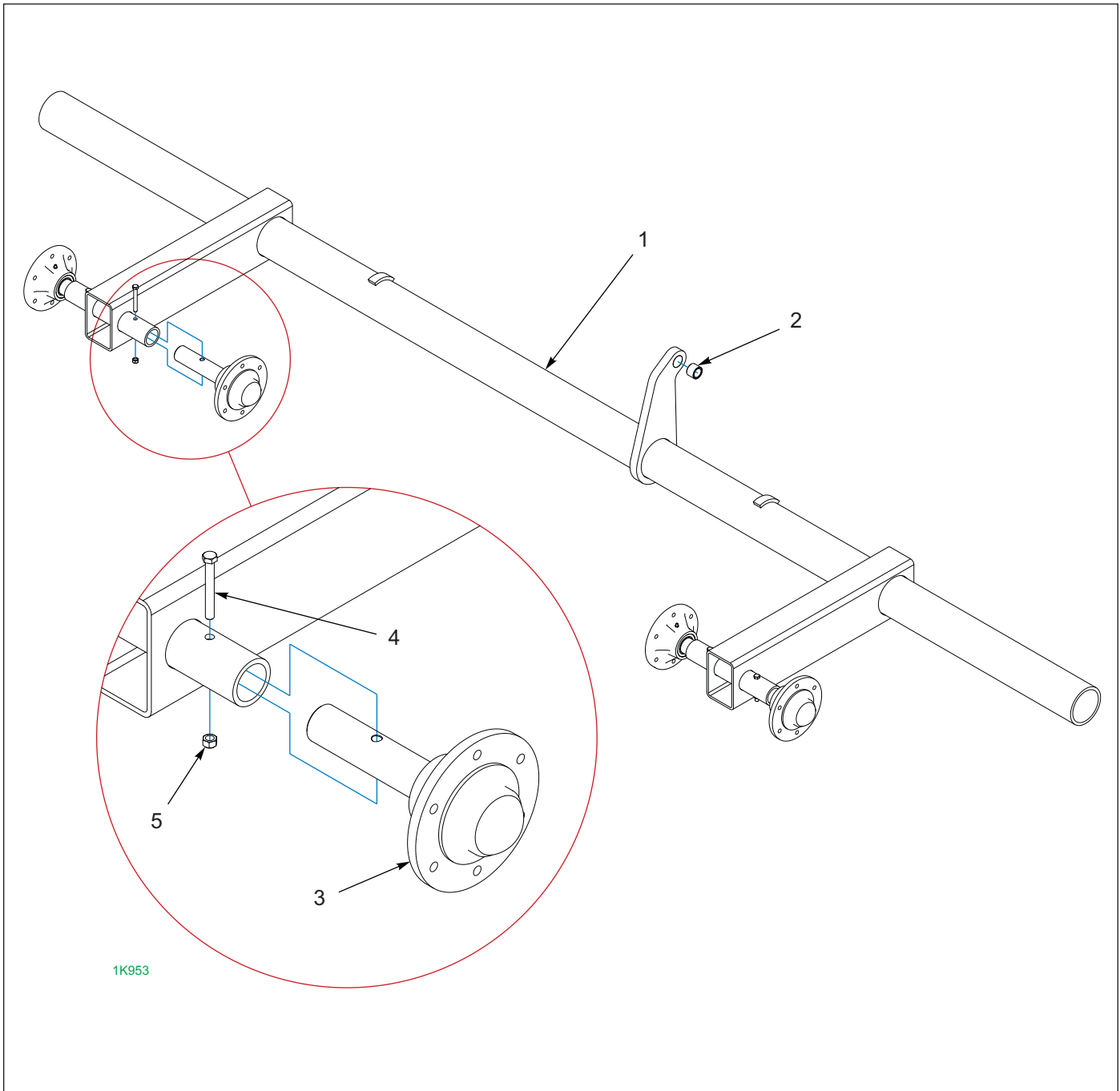

Figure 1-7: Rockshaft Assembly

## Rockshaft Assembly

ITEM	PART NUMBER	DESCRIPTION	QTY
	1K953	ROCK SHAFT	1
1	2K085	ROCKSHAFT WELDMENT (INCLUDES ITEM 2)	1
2	1K892	BUSHING	1
3	6J766	HUB & SPINDLE ASM (PAGE 1-13)	4
4	1-654-010051-13	SCREW, HX CP 3/8-16UNC X 3, GR5	4
5	1-512-010005-05	NUT, HEX SLFLKG GR8 3/8-16	4



# Hub and Spindle Assembly

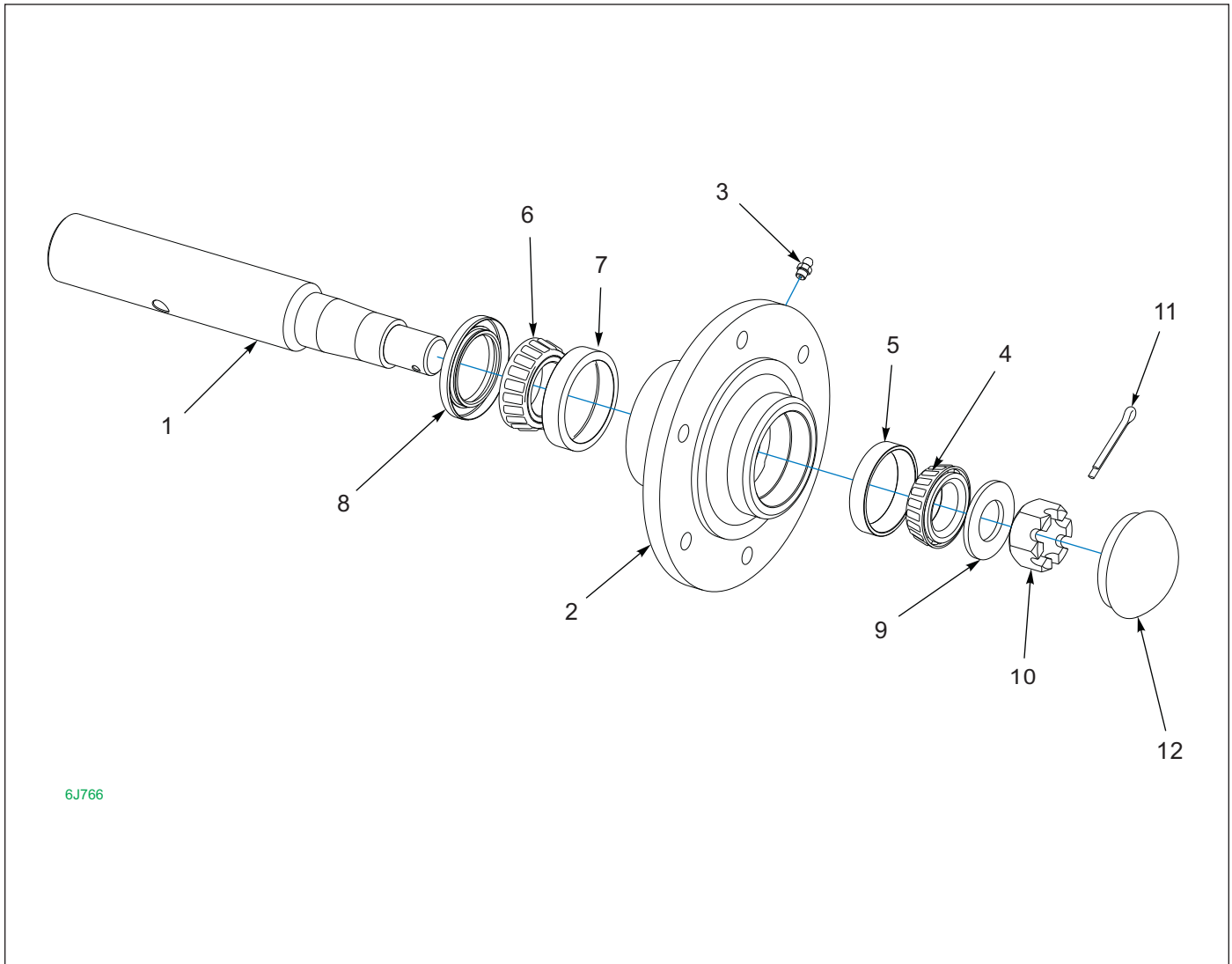

Figure 1-8: Hub and Spindle Assembly

## Hub and Spindle Assembly

ITEM	PART NUMBER	DESCRIPTION	QTY
	6J766	HUB & SPINDLE ASM	1
1	6J765	SPINDLE	1
2	6D336	WHEEL HUB - 6 BOLT (7002537)	1
3	9D923	GREASE FITTING (1/8NPT) (BEFORE 11/15/2011)	1
3	1-298-010001-1	ZERK FITTING 1/4 SAE (AFTER 11/15/2011)	1
4	5C913	BEARING CONE, TIMKEN (LM67048)	1
5	5C914	BEARING CUP, TIMKEN (LM67010)	1
6	5C480	CONE, BEARING (TIMKEN LM48548)	1
7	5C479	CUP, BEARING (TIMKEN LM48510)	1
8	6D338	SEAL (DOUBLE LIP 1-3/4 X 2.625)	1
9	1-861-010032-24	1" NARROW, FLAT WASHER ZP	1
10	1-516-010001-20	NUT, HX SLOT 1-14	1
11	1-557-010362-51	PIN COTTER 3/16 X 1-1/2	1
12	6D337	HUB CAP	1

# Wheel Assembly

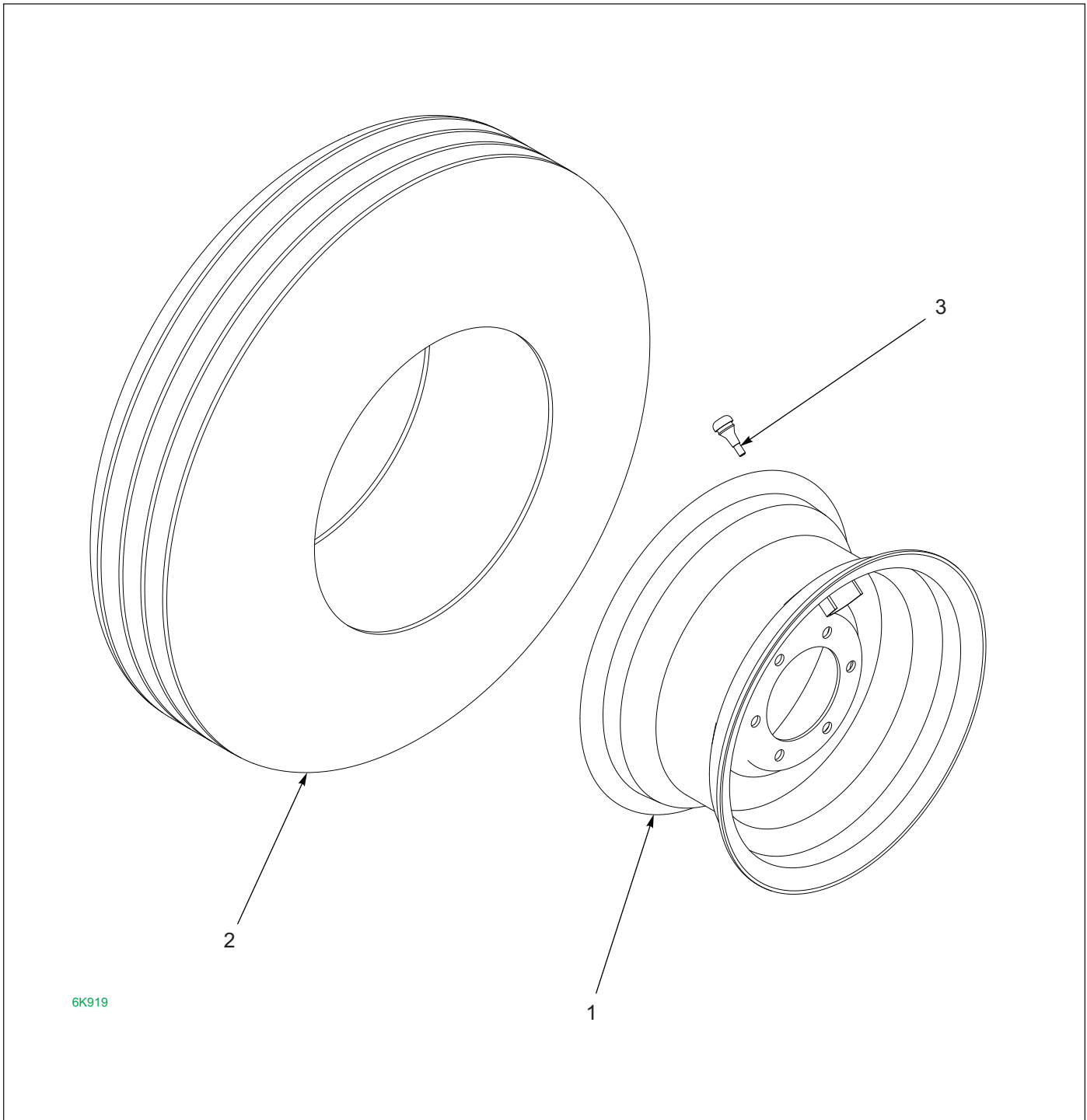

Figure 1-9: Wheel Assembly

# Wheel Assembly

ITEM	PART NUMBER	DESCRIPTION	QTY
	6K919	WHEEL 8J790/NO TUBE/6D312	1
1	6D312	WHEEL - 15 X 8LB - 6 BOLT	1
2	8J790	TIRE - 9.5L X 15 - 6 PLY	1
3	415	VALVE STEM	1



# Independent Tooth Control, C-Tooth

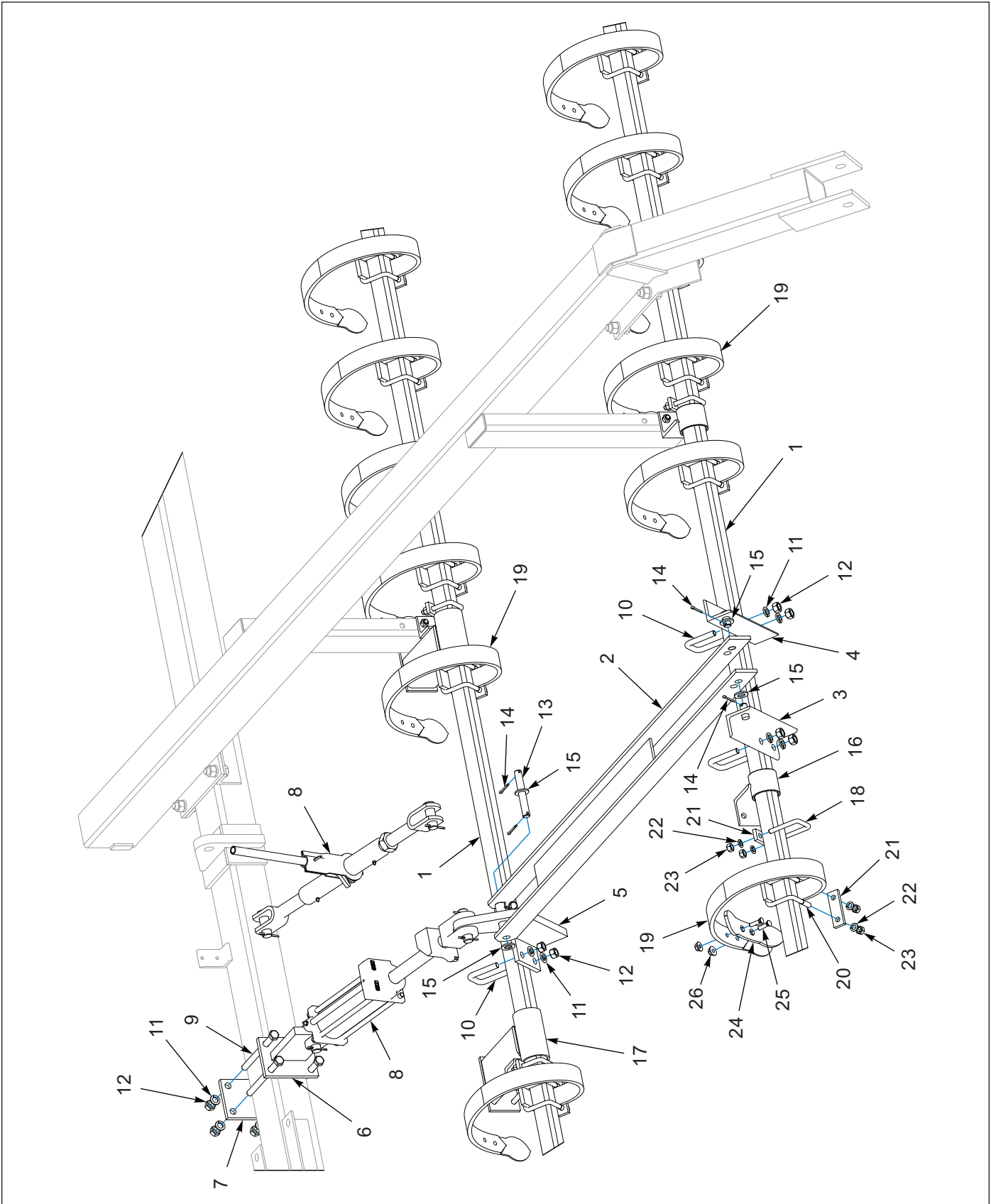

Figure 1-10: Independent Tooth Control, C-Tooth

## Independent Tooth Control, C-Tooth

ITEM	PART NUMBER	DESCRIPTION	QTY
1	1K958	TOOTH TUBE (2 X 210)	2
2	2K672	LINKAGE	1
3	9J096	BRACKET, C-TOOTH FRONT (USED ON RIGHT SIDE)	1
4	9J120	BRACKET, C-TOOTH FRONT (USED ON LEFT SIDE)	1
5	9J218	TOOTH CONTROL BRACKET	1
6	9J216	BRACKET	1
7	9J214	PLATE PAINT RED	1
8	7J237	RATCHET JACK (WITH HANDLE)	1
8	3J603	HYDRAULIC CYLINDER (3 X 8) (SEE PAGES 1-54 AND 1-56)	1
9	1-654-010059-21	SCREW, HEX CAP, 5/8-11UNC X 8, GR5	4
10	2J094	U-BOLT, 5/8-11 X 3-3/8 X 2-5/8	4
11	1-861-010034-15	WASHER 5/8 SLW	12
12	1-512-010007-11	NUT, HEX 5/8-11, ZP	12
13	9J111	PIN (0.75 X 5.313 H2)	1
14	1-557-010362-51	PIN COTTER 3/16 X 1-1/2	4
15	1-861-010032-20	WASHER FL 3/4 SAE, ZP	4
16	9J090	BRACKET, C-TOOTH	6
17	3K074	BRACKET, C-TOOTH	2
18	5D921	U-BOLT 1/2-13 X 3-1/4 X 2-5/8	4
19	9D662	SPRING TOOTH - REPLACES 5C004	35
20	8J172	TOOTH CLAMP	35
21	5C078	CLAMP STRAP	39
22	1-861-010034-13	WASHER, LOCK 1/2, ZP	78
23	1-512-010007-09	NUT HEX 1/2-13, ZP	78
24	4D386	REVERSIBLE POINT	1
25	2C628	PLOW BOLT 3/8-16 X 1-1/2 SQ NK	2
26	5J616	FLANGE LOCK NUT 3/8-16	2

# Independent Tooth Control, S-Tine

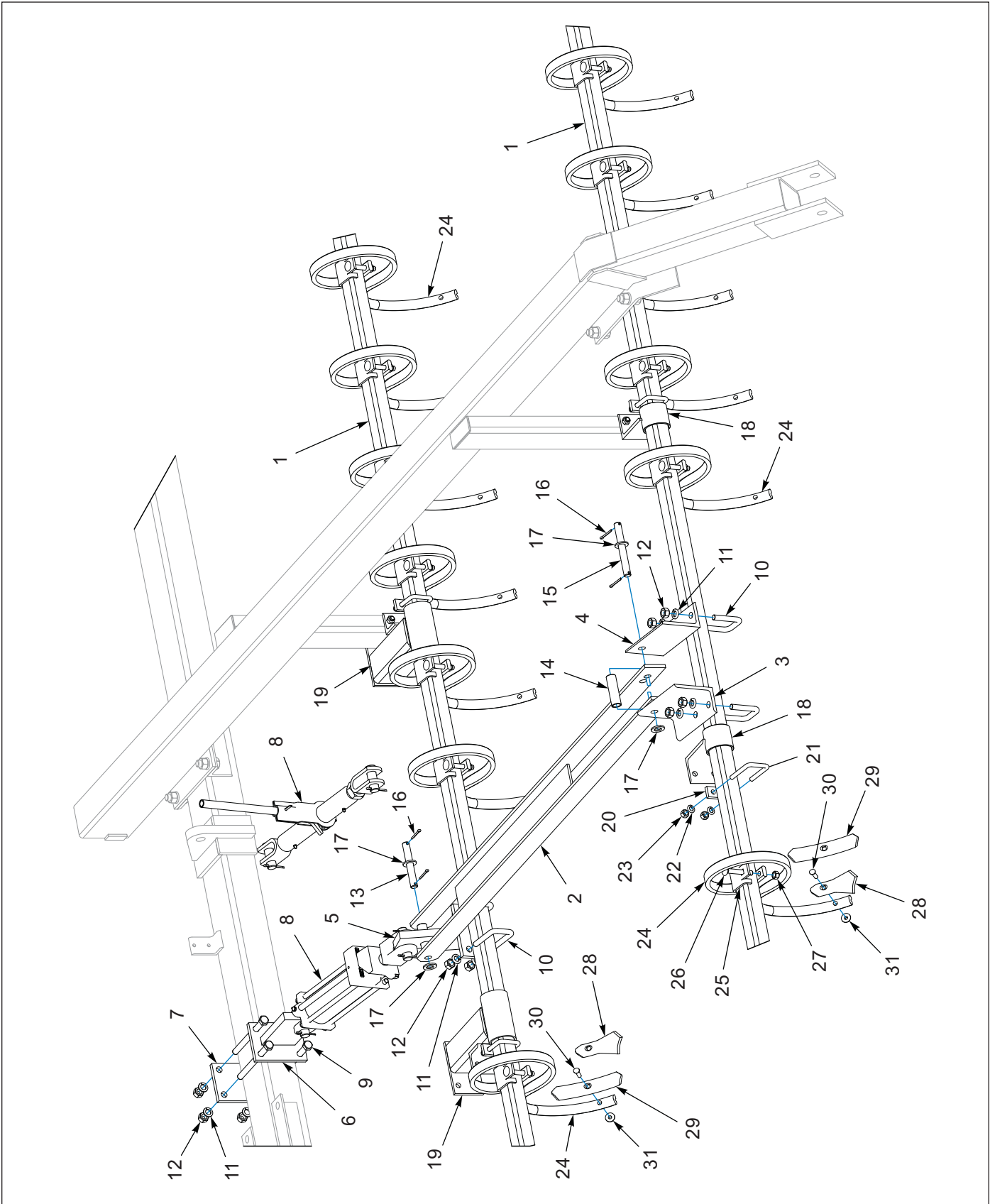

Figure 1-11: Independent Tooth Control, S-Tine

## Independent Tooth Control, S-Tine

ITEM	PART NUMBER	DESCRIPTION	QTY
1	1K958	TOOTH TUBE (2 X 210)	2
2	2K672	LINKAGE	1
3	9J109	ANGLE, S-TINE RH	1
4	9J108	ANGLE, S-TINE LH	1
5	9J220	TOOTH CONTROL BRACKET	1
6	9J216	BRACKET	1
7	9J214	PLATE PAINT RED	1
8	7J237	RATCHET JACK (WITH HANDLE)	1
8	3J603	HYDRAULIC CYLINDER (3 X 8) (SEE PAGES 1-54 AND 1-56)	1
9	1-654-010059-21	SCREW, HEX CAP, 5/8-11UNC X 8, GR5	4
10	2J094	U-BOLT, 5/8-11 X 3-3/8 X 2-5/8	4
11	1-861-010034-15	WASHER, 5/8 SLW	12
12	1-512-010007-11	NUT, HEX 5/8-11, ZP	12
13	9J111	PIN (0.75 X 5.313 H2)	1
14	9J112	SPACER (0.824 X 1.05 X 3.5)	1
15	9J110	PIN (0.75 X 6.313 H2)	1
16	1-557-010362-51	PIN, COTTER 3/16 X 1-1/2	4
17	1-861-010032-20	WASHER, FL 3/4 SAE, ZP	4
18	9J091	BRACKET, S-TINE	6
19	3K073	BRACKET, S-TINE	2
20	5C078	CLAMP STRAP	4
21	5D921	U-BOLT, 1/2-13 X 3-1/4 X 2-5/8	4
22	1-861-010034-13	WASHER, LOCK 1/2 ZP	8
23	1-512-010007-09	NUT HEX 1/2-13, ZP	8
24	1J887	S-TINE, 10mm X 32mm (BEFORE 01/01/1993)	35
24	5J609	S-TINE, 12mm X 32mm (AFTER 01/01/1993)	35
25	1J834	CLAMP (BEFORE 01/01/1993)	35
25	5J080	CLAMP (AFTER 01/01/1993)	35
26	2J241	SCREW 7/16-14NC X 3-1/2 RDHD SQNK (BEFORE 01/01/1993)	35
26	1-654-010070-11	SCREW, RDHD, SQNK 1/2-13 X 3-1/2 (AFTER 01/01/1993)	35
27	101988	NUT, HEX SLF-LKG 7/16-14 GRB (BEFORE 01/01/1993)	35
27	1-512-010005-09	NUT, HEX SLFLKG, 1/2-13 GRB (AFTER 01/01/1993)	35
28	7D014	DUCKFOOT POINT	35
29	2J155	HEAVY DUTY REVERSIBLE POINT	35
30	7D728	CULTIVATOR BOLT (3/8-16 X 1-3/4 GR5, #8 HEAD)	35
31	5J616	FLANGE LOCK NUT 3/8-16	35

Tooth Control, C-Tooth

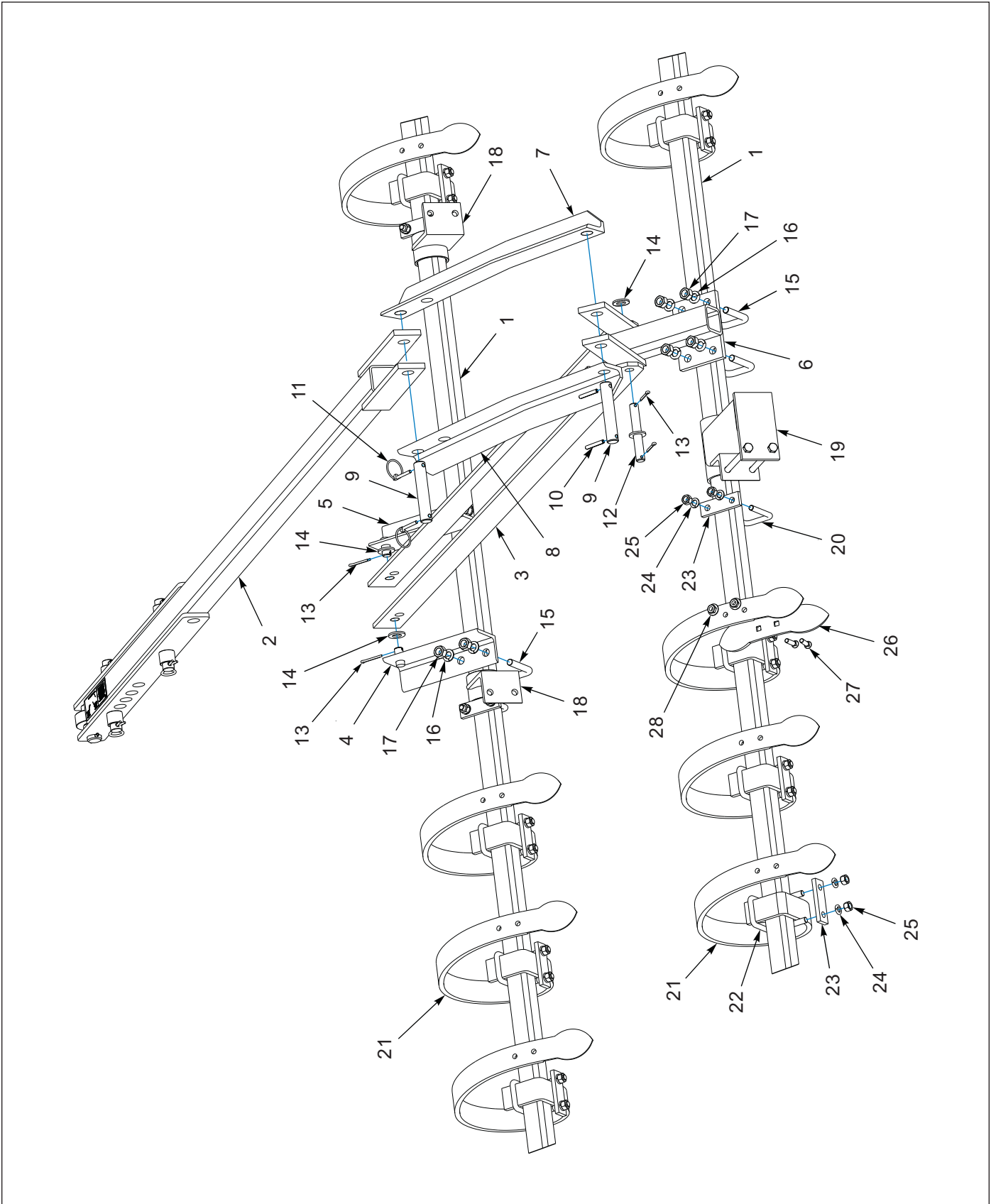

Figure 1-12: Tooth Control, C-Tooth



## Tooth Control, C-Tooth

ITEM	PART NUMBER	DESCRIPTION	QTY
1	1K958	TOOTH TUBE (2 X 210)	2
2	8J083	LINK	1
3	2K672	LINKAGE	1
4	9J096	BRACKET, C-TOOTH FRONT (USED ON LEFT SIDE)	1
5	9J120	BRACKET, C-TOOTH FRONT (USED ON RIGHT SIDE)	1
6	9J107	REAR BRACKET	1
7	9J146	LINK, C-TOOTH (RH)	1
8	9J145	LINK, C-TOOTH (LH)	1
9	5J768	PIN (1.0 X 5.50 H2)	2
10	147072	ROLL PIN 5/16 X 2	2
11	5D110	KLIK PIN 1/4 X 1-1/4	2
12	9J111	PIN (0.75 X 5.313 H2)	1
13	1-557-010362-51	PIN COTTER 3/16 X 1-1/2	4
14	1-861-010032-20	WASHER, FL 3/4 SAE, ZP	4
15	2J094	U-BOLT, 5/8-11 X 3-3/8 X 2-5/8	4
16	1-861-010034-15	WASHER, 5/8 SLW	8
17	1-512-010007-11	NUT, HEX 5/8-11, ZP	8
18	9J090	BRACKET, C-TOOTH	6
19	3K074	BRACKET, C-TOOTH	2
20	5D921	U-BOLT, 1/2-13 X 3-1/4 X 2-5/8	4
21	9D662	SPRING TOOTH - REPLACES 5C004	35
22	8J172	TOOTH CLAMP	35
23	5C078	CLAMP STRAP	39
24	1-861-010034-13	WASHER, LOCK 1/2, ZP	78
25	1-512-010007-09	NUT HEX 1/2-13, ZP	78
26	4D386	REVERSIBLE POINT	1
27	2C628	PLOW BOLT 3/8 X 1-1/2 SQ NK	2
28	5J616	FLANGE LOCK NUT 3/8-16	2

Tooth Control, S-Tine

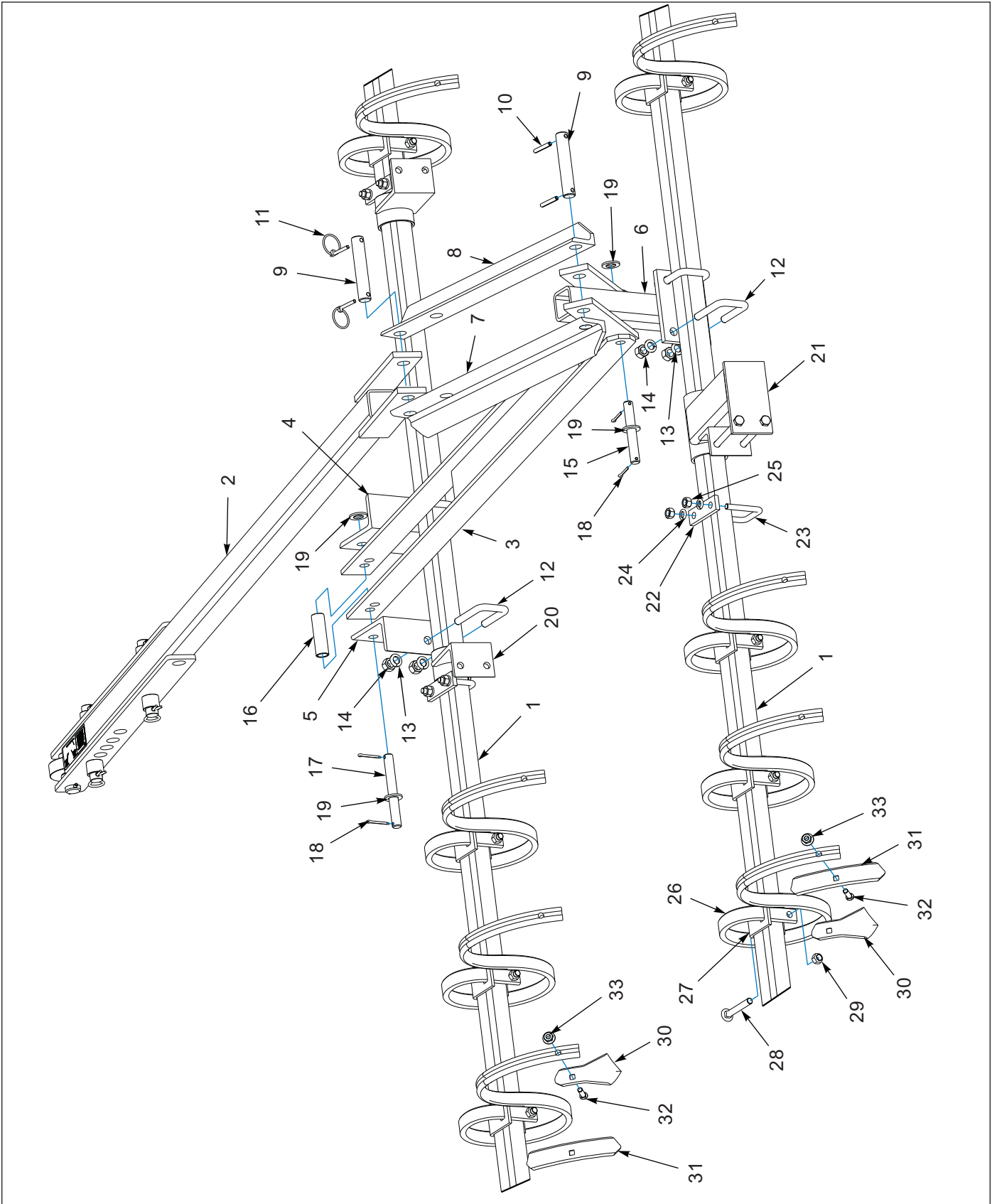

Figure 1-13: Tooth Control, S-Tine

## Tooth Control, S-Tine

ITEM	PART NUMBER	DESCRIPTION	QTY
1	1K958	TUBE (2 X 210)	2
2	8J083	LINK	1
3	2K672	LINKAGE	1
4	9J109	ANGLE, S-TINE RH	1
5	9J108	ANGLE, S-TINE LH	1
6	9J114	REAR BRACKET	1
7	9J143	LINK, S-TINE LH	1
8	9J144	LINK, S-TINE RH	1
9	5J768	PIN (1.0 X 5.50 H2)	2
10	147072	ROLL PIN 5/16 X 2"	2
11	5D110	KLIK PIN 1/4 X 1-3/4	2
12	2J094	U-BOLT, 5/8-11 X 3-3/8 X 2-5/8	4
13	1-861-010034-15	WASHER, 5/8 SLW	8
14	1-512-010007-11	NUT, HEX 5/8-1,1 ZP	8
15	9J111	PIN (0.75 X 5.313 H2)	1
16	9J112	SPACER (0.824 X 1.05 X 3.5)	1
17	9J110	PIN (0.75 X 6.313 H2)	1
18	1-557-010362-51	PIN, COTTER 3/16 X 1-1/2	4
19	1-861-010032-20	WASHER FL 3/4 SAE, ZP	4
20	9J091	BRACKET, S-TINE	6
21	3K073	BRACKET, S-TINE	2
22	5C078	CLAMP STRAP	4
23	5D921	U-BOLT, 1/2-13 X 3-1/4 X 2-5/8	4
24	1-861-010034-13	WASHER LOCK 1/2, ZP	8
25	1-512-010007-09	NUT HEX 1/2-13 ZP	8
26	1J887	S-TINE, 10mm X 32mm (BEFORE 01/01/1993)	35
26	5J609	S-TINE, 12mm X 32mm (AFTER 01/01/1993)	35
27	1J834	CLAMP (BEFORE 01/01/1993)	35
27	5J080	CLAMP (AFTER 01/01/1993)	35
28	2J241	SCREW, 7/16-14NC X 3-1/2 RDHD SQNK (BEFORE 01/01/1993)	35
28	1-654-010070-11	SCREW, RDHD, SQNK 1/2-13 X 3-1/2 (AFTER 01/01/1993)	35
29	101988	NUT, HEX SLF-LKG 7/16-14 GRB (BEFORE 01/01/1993)	35
29	1-512-010005-09	NUT, HEX SLFLKG, 1/2-13 GRB (AFTER 01/01/1993)	35
30	7D014	DUCKFOOT POINT	35
31	2J155	HEAVY DUTY REVERSIBLE POINT	35
32	7D728	CULTIVATOR BOLT (3/8-16 X 1-3/4 GR5, #8 HEAD)	35
33	5J616	FLANGE LOCK NUT 3/8-16	35

Roller

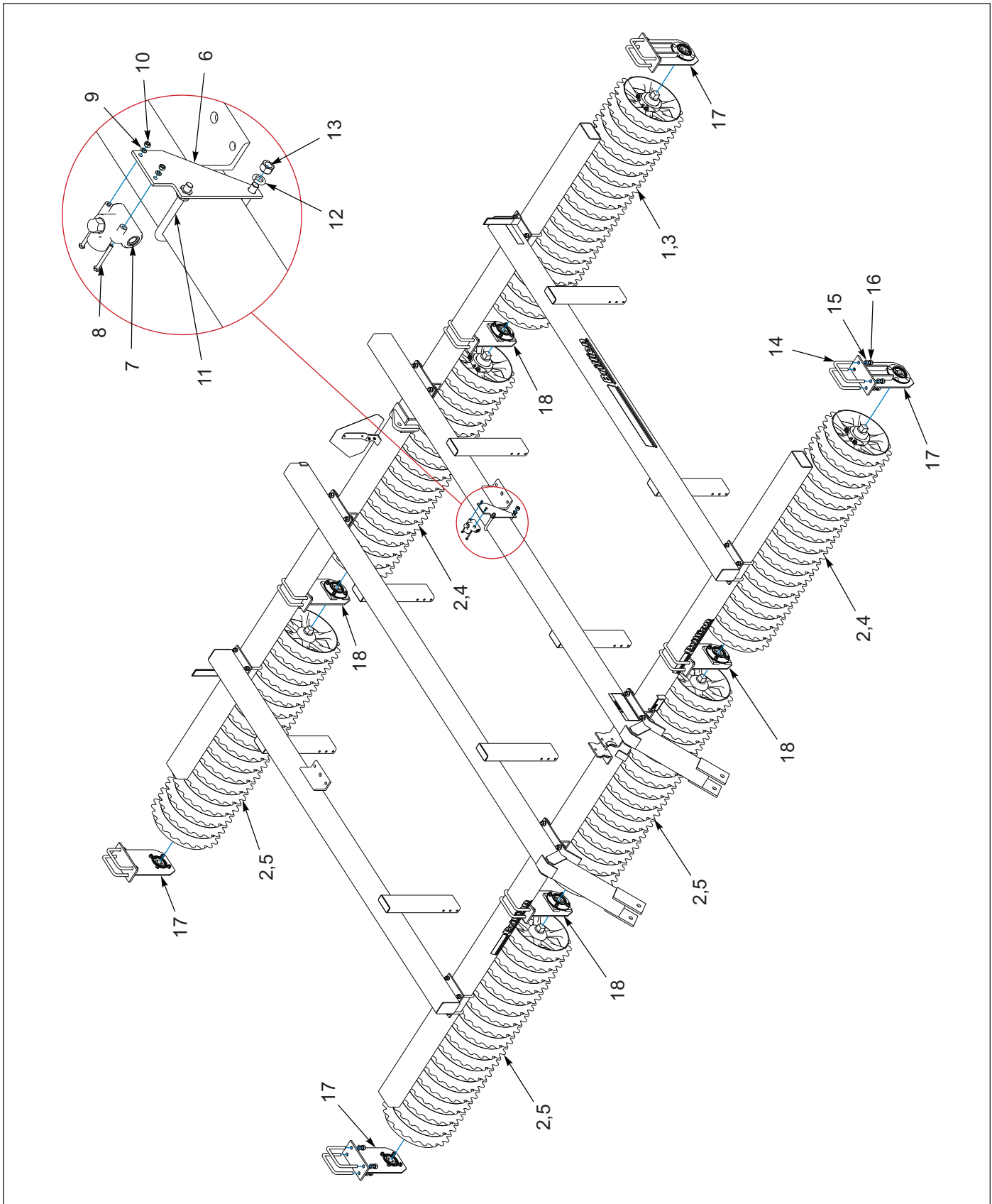

Figure 1-14: Roller

## Roller

ITEM	PART NUMBER	DESCRIPTION	QTY
1	9J522	WHL&AXLE,76" NOTCHED	1
1	168371	WHL&AXLE REPL STUB, 76" NOTCH <b>(ALLOWS FOR STUB REPLACEMENT)</b>	1
2	9J523	WHL&AXLE,72" NOTCHED	5
2	168372	WHL&AXLE REPL STUB, 72" NOTCH <b>(ALLOWS FOR STUB REPLACEMENT)</b>	5
3	9J830	WHL&AXLE, 76" LH CROWFT <b>(CROWFOOT)</b>	1
3	168367	WHL&AXLE REPLSTUB,76" LH CRWFT <b>(ALLOWS FOR STUB REPLACEMENT)</b>	1
4	9J832	WHL&AXLE,72" LH CROWFT <b>(CROWFOOT)</b>	2
4	168365	WHL&AXLE, REPLSTUB,72" LH CRWFT <b>(ALLOWS FOR STUB REPLACEMENT)</b>	2
5	9J833	WHL&AXLE,72" RH CROWFT	3
5	168366	WHL&AXLE REPLSTUB,72" RH CRWFT <b>(ALLOWS FOR STUB REPLACEMENT)</b>	3
6	9J187	BRACKET	1
7	8J650	RELIEF VALVE	1
8	1-654-010047-12	SCREW, HEX CAP 1/4-20UNC X 2-1/2 <b>(GR5, ZP)</b>	2
9	1-861-010034-09	WASHER, LOCK 1/4, ZP	2
10	1-512-010007-05	NUT, HEX 1/4-20, ZP	2
11	7J990	U-BOLT, 5/8-11 X 5-1/2 X 6-11/16	1
12	1-861-010034-15	WASHER 5/8 SLW	1
13	1-512-010007-11	NUT, HEX 5/8-11, ZP	1
14	3J450	U-BOLT, 3/4-10 X 6-13/16 X 5-3/4	16
15	1-861-010034-17	WASHER, LKG, HLCL SPR, 3/4	32
16	1-512-010007-12	NUT HEX 3/4-10, ZP	32
17	9J560	END BRACKET ASSEM	4
18	9J883	CENTER BRACKET ASSEM	4

# Center Bracket Assembly

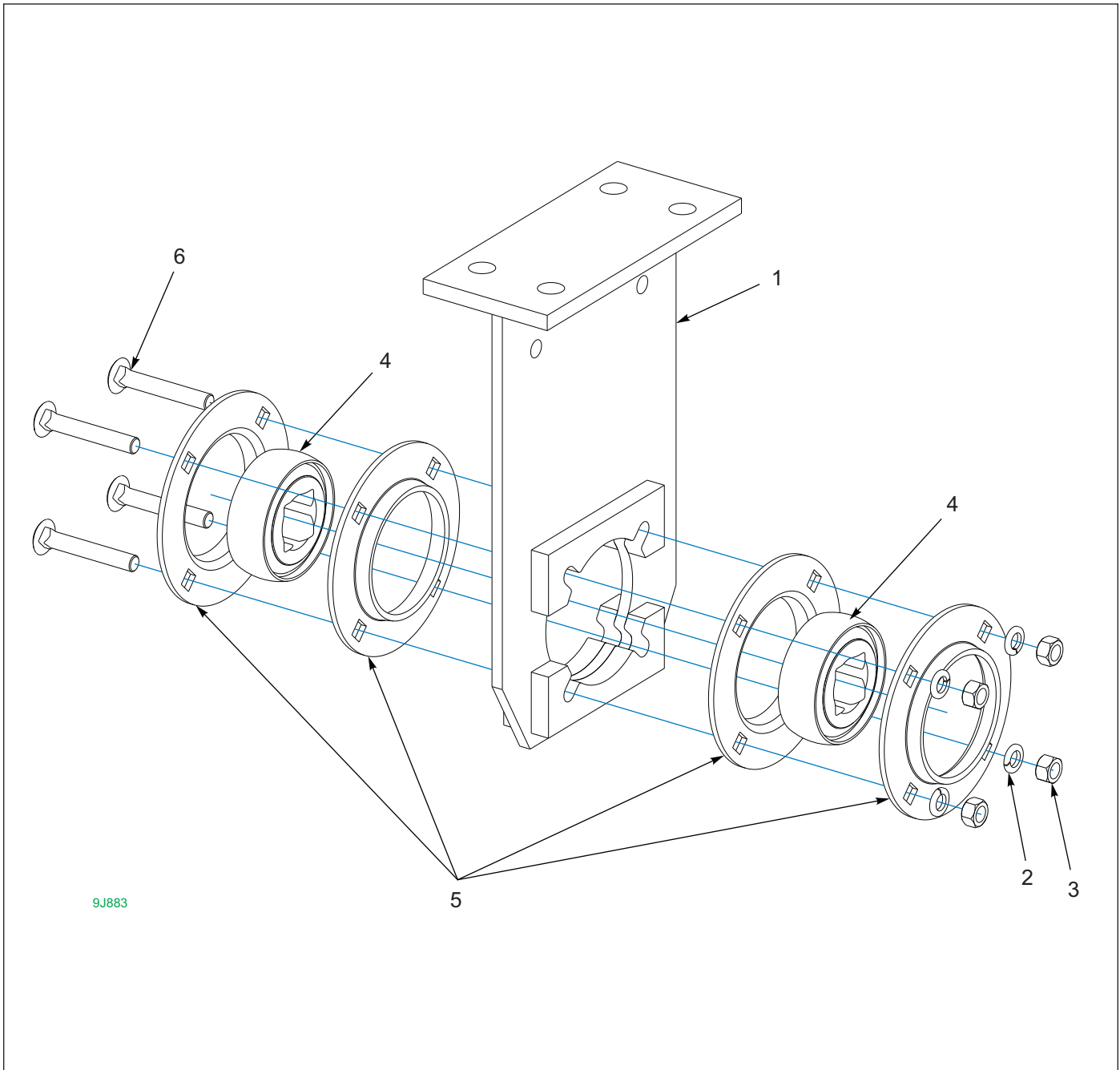
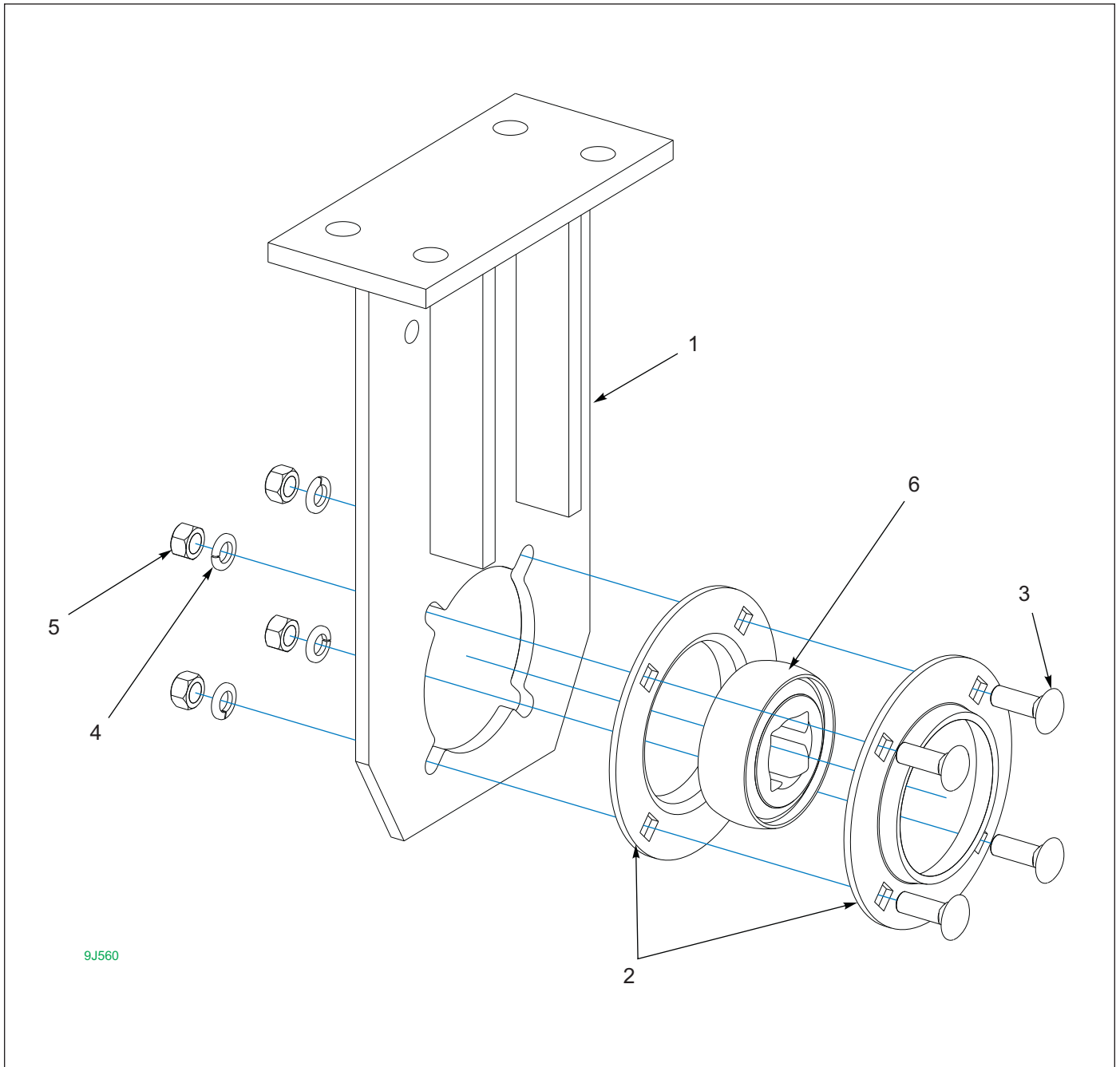

Figure 1-15: Center Bracket Assembly

## Center Bracket Assembly

ITEM	PART NUMBER	DESCRIPTION	QTY
	9J883	CENTER BRACKET ASSEM	1
1	9J882	CENTER BRACKET	1
2	1-861-010034-13	WASHER, LOCK 1/2, ZP	4
3	1-512-010007-09	NUT, HEX 1/2-13, ZP	4
4	3J131	BEARING (1-1/2" SQUARE)	2
5	3K045	BEARING FLANGE ZINC PLATED	4
6	9J570	CARRIAGE BOLT (1/2-13 X 3-1/4 GR5, ZP)	4

# End Bracket Assembly



**Figure 1-16: End Bracket Assembly**

## End Bracket Assembly

ITEM	PART NUMBER	DESCRIPTION	QTY
	9J560	END BRACKET ASSEM	1
1	9J561	END BRACKET	1
2	3K045	BEARING FLANGE ZINC PLATED	2
3	1-654-010070-03	SCREW, RDHD SQNK 1/2-13 X 1-1/2	4
4	1-861-010034-13	WASHER, LOCK 1/2, ZP	4
5	1-512-010007-09	NUT, HEX 1/2-13, ZP	4
6	3J131	BEARING (1-1/2 SQUARE)	1

### Wheel and Axle Assemblies, Notched

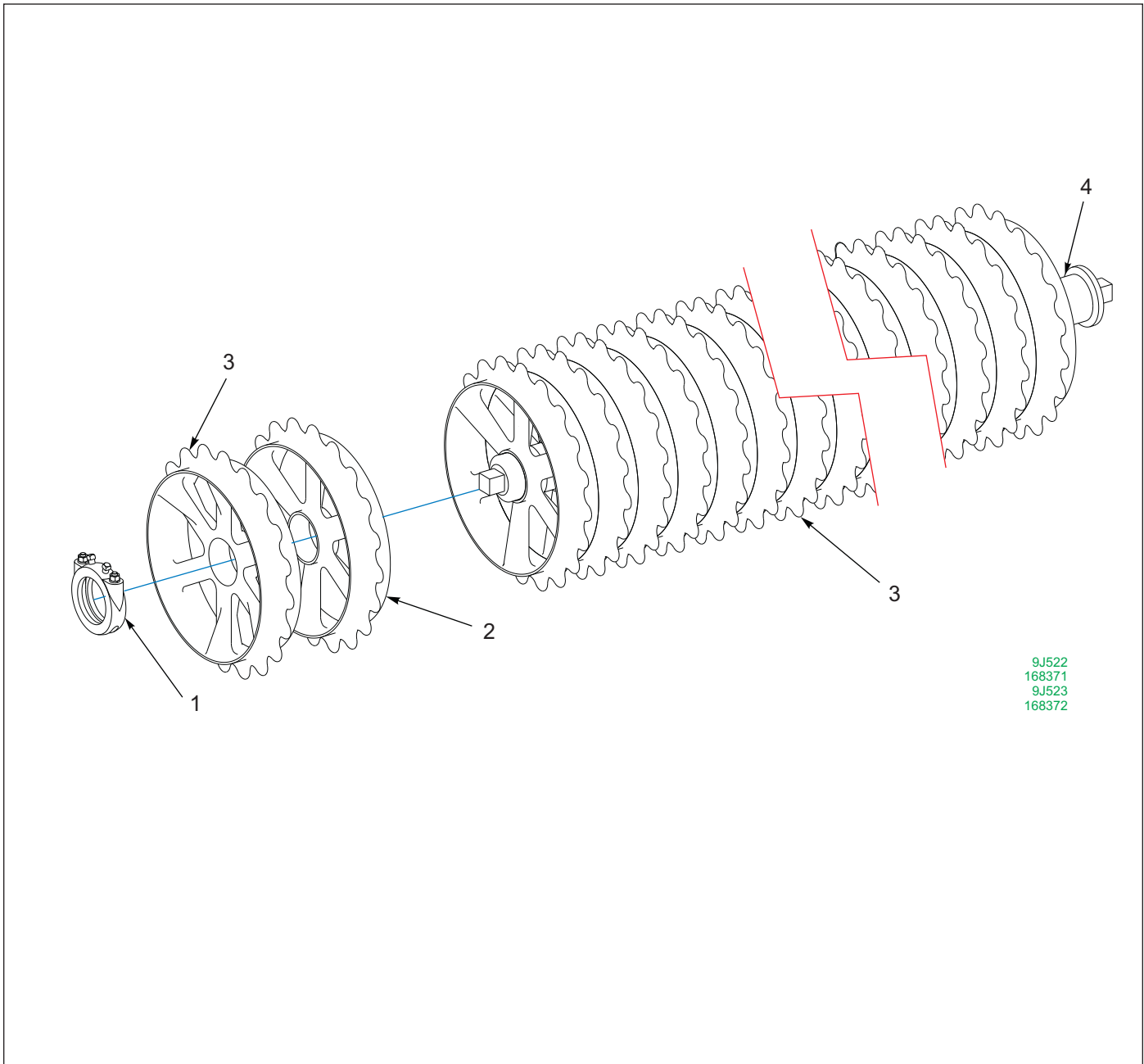

Figure 1-17: Wheel and Axle Assemblies, Notched

### Wheel and Axle Assemblies, Notched

ITEM	PART NUMBER	DESCRIPTION	QTY	
			72"	76"
	9J523	WHL&AXLE,72" NOTCHED	1	--
	9J522	WHL&AXLE,76" NOTCHED	--	1
1	5J375	AXLE CLAMP ASSEM (PAGE 1-32)	1	1
2	8J001	20" DUCTILE NOTCHED 7004107	16	17
3	9J500	20" DUCTILE END WHEEL 700458	2	2
4	9J516	PIPE AXLE,72" (PAGE 1-34)	1	--
4	9J515	PIPE AXLE,76" (PAGE 1-34)	--	1



## Wheel and Axle Assemblies, Notched with Replaceable Stub

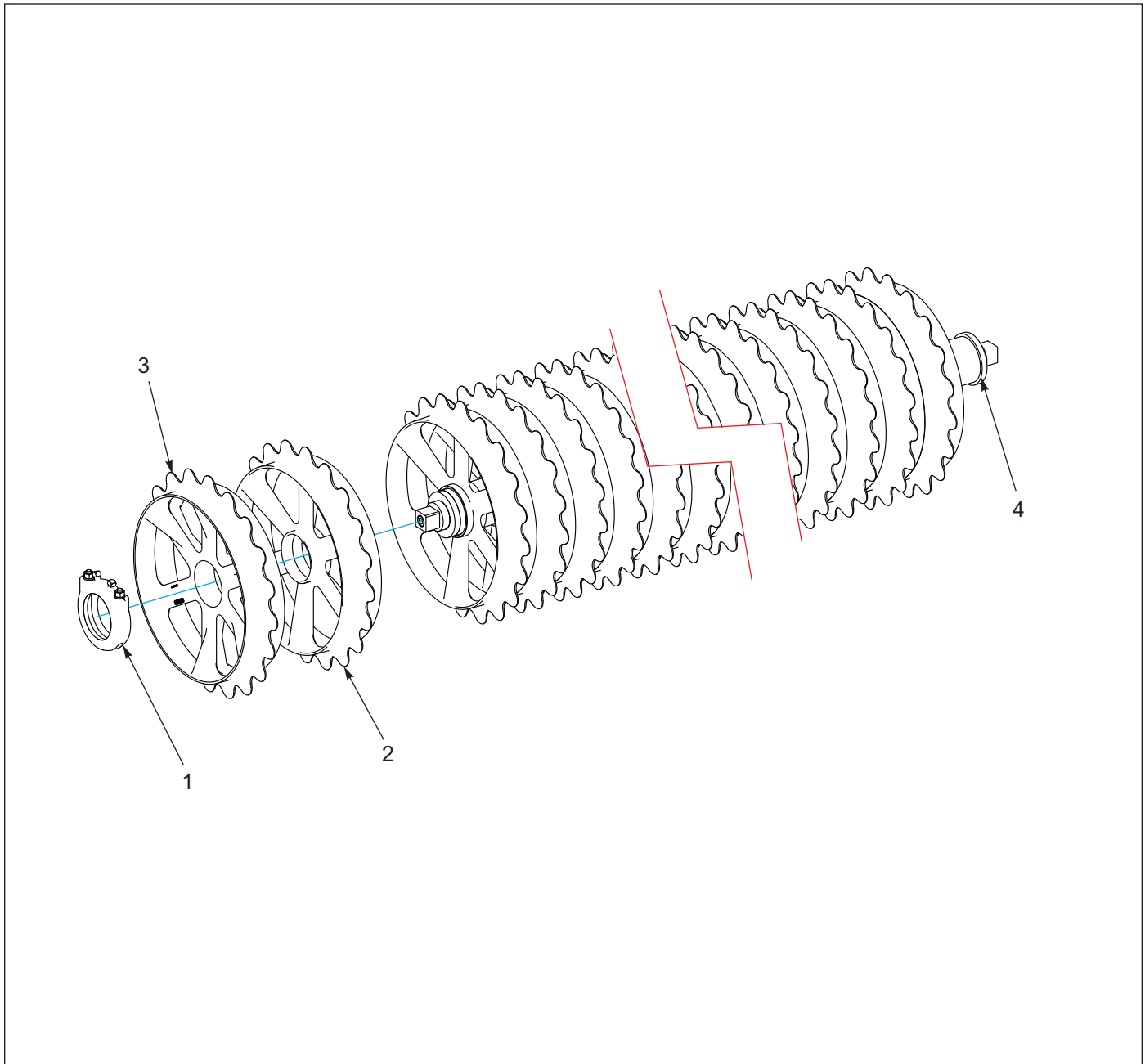

**Figure 1-18: Wheel and Axle Assemblies, Notched with Replaceable Stub**

## Wheel and Axle Assemblies, Notched with Replaceable Stub

ITEM	PART NUMBER	DESCRIPTION	QTY	
			72"	76"
	168372	WHL&AXLE REPL STUB,72" NOTCH	1	--
	168371	WHL&AXLE REPL STUB,76" NOTCH	--	1
1	5J375	AXLE CLAMP ASSEM ( <b>PAGE 1-32</b> )	1	1
2	8J001	20" DUCTILE NOTCHED 7004107	16	17
3	9J500	20" DUCTILE END WHEEL 700458	2	2
4	6K170	PIPE AXLE REPL STUB,72" ( <b>PAGE 1-35</b> )	1	--
4	6K169	PIPE AXLE REPL STUB,76" ( <b>PAGE 1-35</b> )	--	1

# Wheel and Axle Assembly, Crowfoot

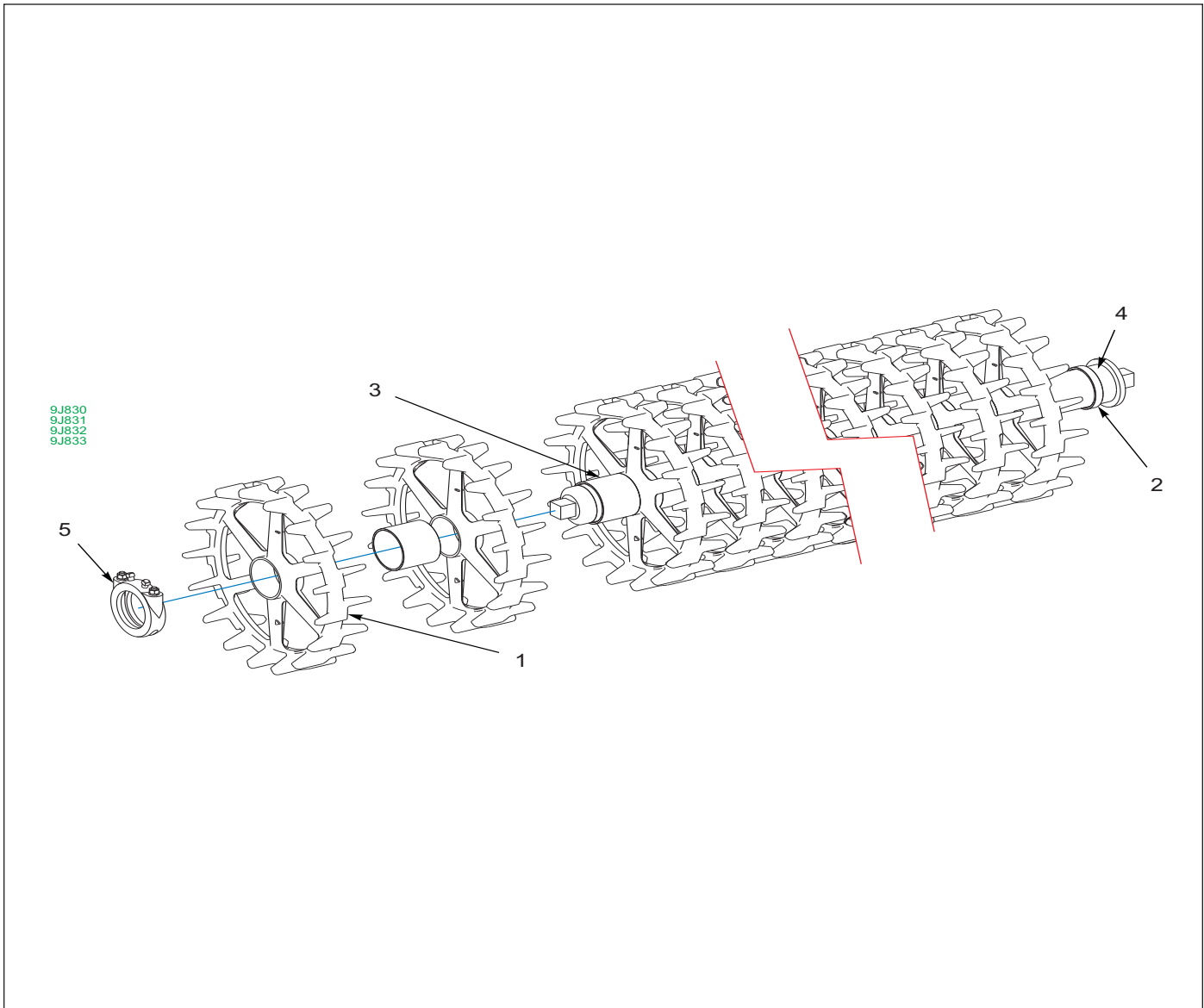

Figure 1-19: Wheel and Axle Assembly, Crowfoot

## Wheel and Axle Assembly, Crowfoot

ITEM	PART NUMBER	DESCRIPTION	QTY	
			72"	76"
	9J832	WHL&AXLE,72" LH CROWFT	1	--
	9J833	WHL&AXLE,72" RH CROWFT	1	--
	9J830	WHL&AXLE,76" LH CROWFT	--	1
1	9J811	20" DUCTILE CROWFOOT 704582	12	13
2	9J818	SPACER (3/4" LONG)	1	--
2	9J277	SPACER RING (11 GAUGE THICK)	--	1
3	9J820	SPACER (3-11/16" LONG)	11	--
3	9J819	SPACER (3-9/16" LONG)	--	12
4	9J516	PIPE AXLE,72" (PAGE 1-34)	1	--
4	9J515	PIPE AXLE,76" (PAGE 1-34)	--	1
5	5J375	AXLE CLAMP ASSEM (PAGE 1-32)	1	1

## Wheel and Axle Assembly, Crowfoot With Replaceable Stub

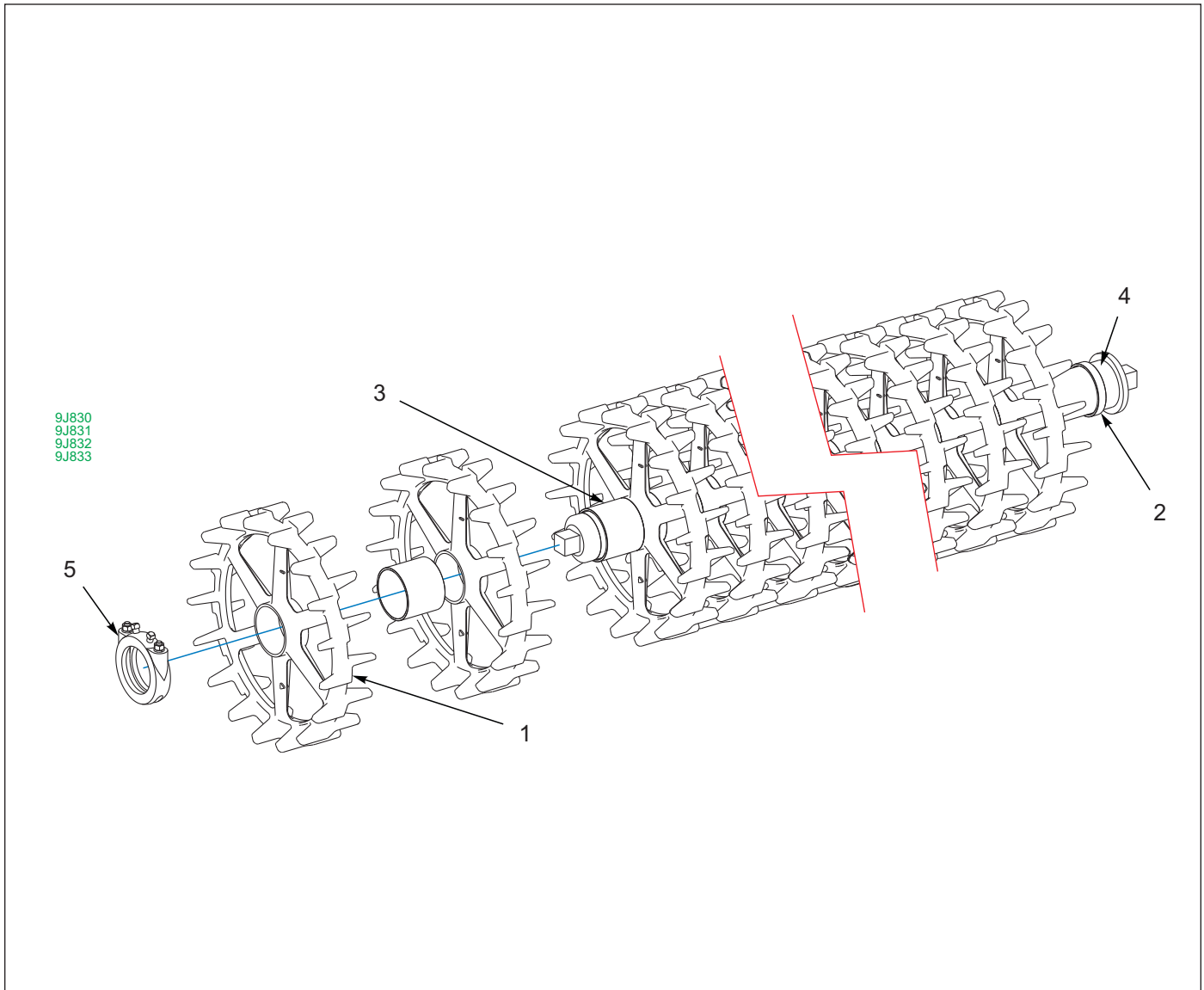

Figure 1-20: Wheel and Axle Assembly, Crowfoot With Replaceable Stub

## Wheel and Axle Assembly, Crowfoot With Replaceable Stub

ITEM	PART NUMBER	DESCRIPTION	QTY	
			72"	76"
	168365	WHL&AXLE REPLSTUB,72" LH CRWFT	1	--
	168366	WHL&AXLE REPLSTUB,72" RH CRWFT	1	--
	168367	WHL&AXLE REPLSTUB,76" LH CRWFT	--	1
1	9J811	20" DUCTILE CROWFOOT 7004582	12	13
2	9J818	SPACER (3/4" LONG)	1	--
2	9J277	SPACER RING (11 GAUGE THICK)	--	1
3	9J820	SPACER (3-11/16" LONG)	11	--
3	9J819	SPACER (3-9/16" LONG)	--	12
4	6K170	PIPE AXLE REPL STUB,72" (PAGE 1-35)	1	--
4	6K169	PIPE AXLE REPL STUB,76" (PAGE 1-35)	--	1
5	5J375	AXLE CLAMP ASSEM (PAGE 1-32)	1	1

## Axle Clamp Assembly

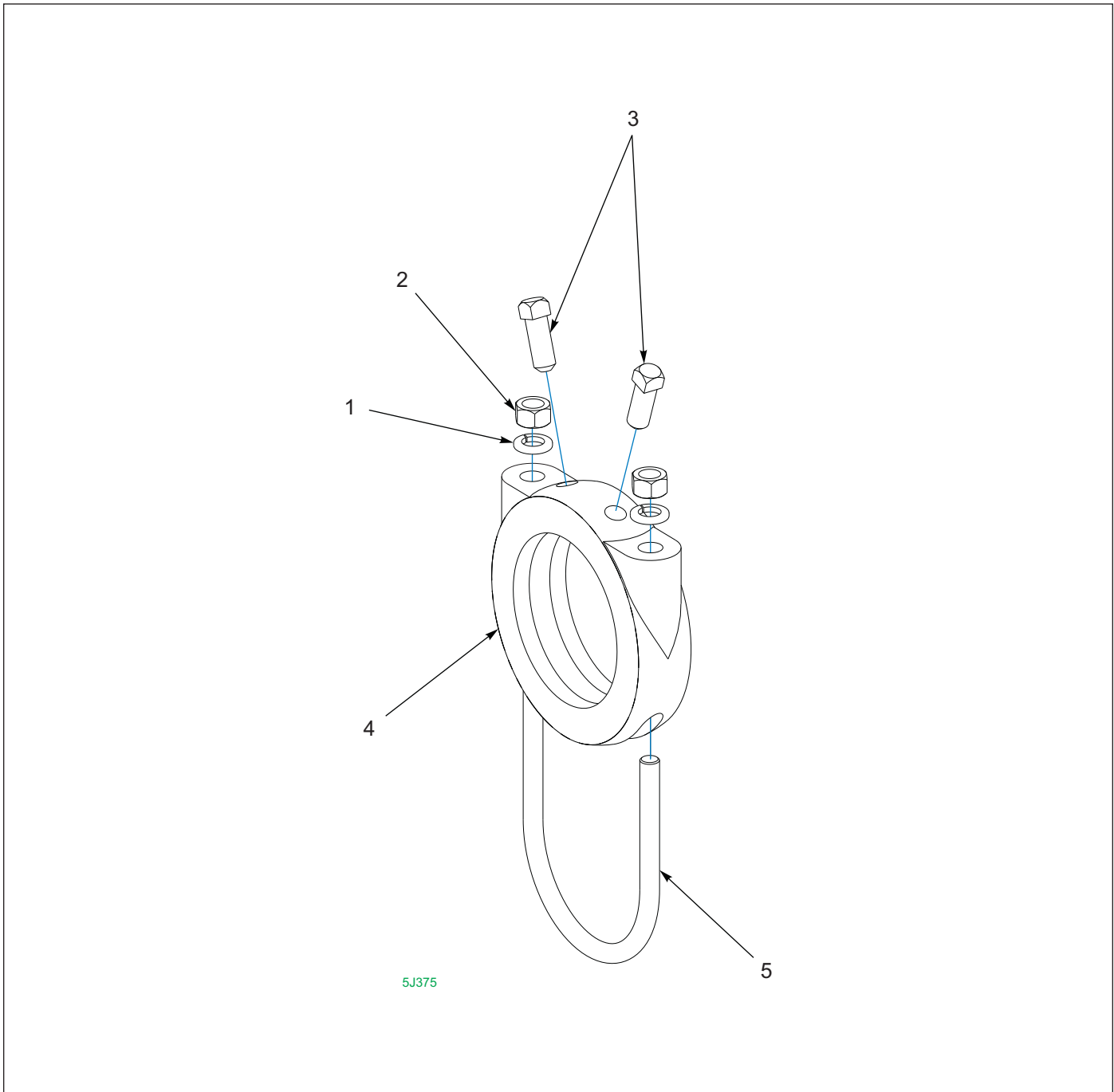

Figure 1-21: Axle Clamp Assembly

## Axle Clamp Assembly

ITEM	PART NUMBER	DESCRIPTION	QTY
	5J375	AXLE CLAMP ASSEM	1
1	1-861-010034-13	WASHER, LOCK 1/2, ZP	2
2	1-512-010007-09	NUT HEX 1/2-13, ZP	2
3	1-654-010080-2	SCREW SET SQHD CPPT 1/2 X 1-1/4	2
4	9C031	AXLE CLAMP 7000747	1
5	9D673	U-BOLT, 1/2-13 X 3-1/4 X 4-9/16	1



# Pipe Axle Assembly

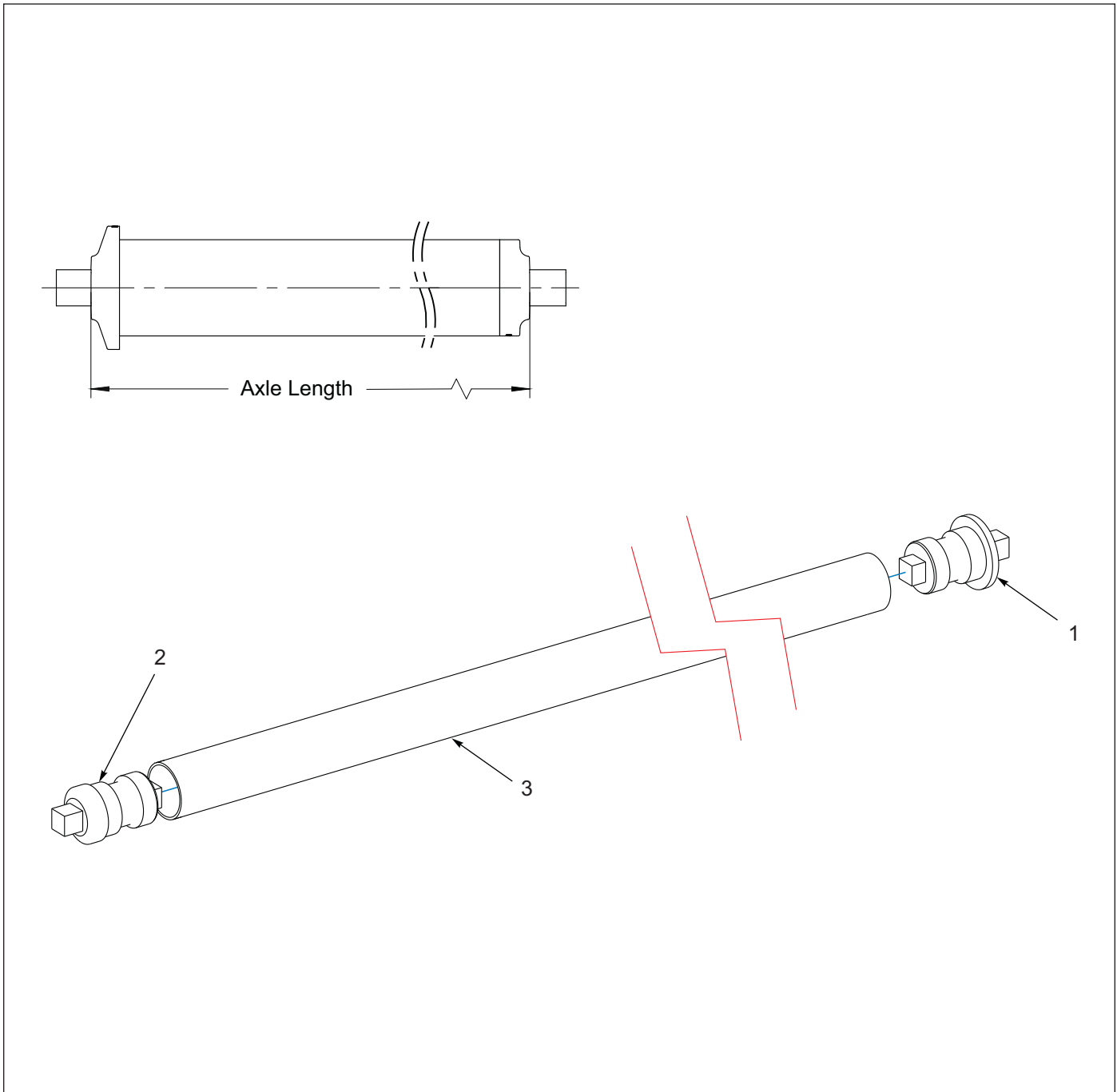

Figure 1-22: Pipe Axle Assembly

## Pipe Axle Assembly

ITEM	PART NUMBER	DESCRIPTION	QUANTITY	
			72"	76"
	9J516	PIPE AXLE,72"	1	--
	9J515	PIPE AXLE,76"	--	1
1	9J502	STUB SHAFT MOUNTING	1	1
2	9J503	STUB SHAFT MOUNTING	1	1
3	-----	NOT SOLD SEPERATELY, ORDER ASSEMBLY TO REPLACE	1	1

### Pipe Axle Assembly With Replaceable Stub

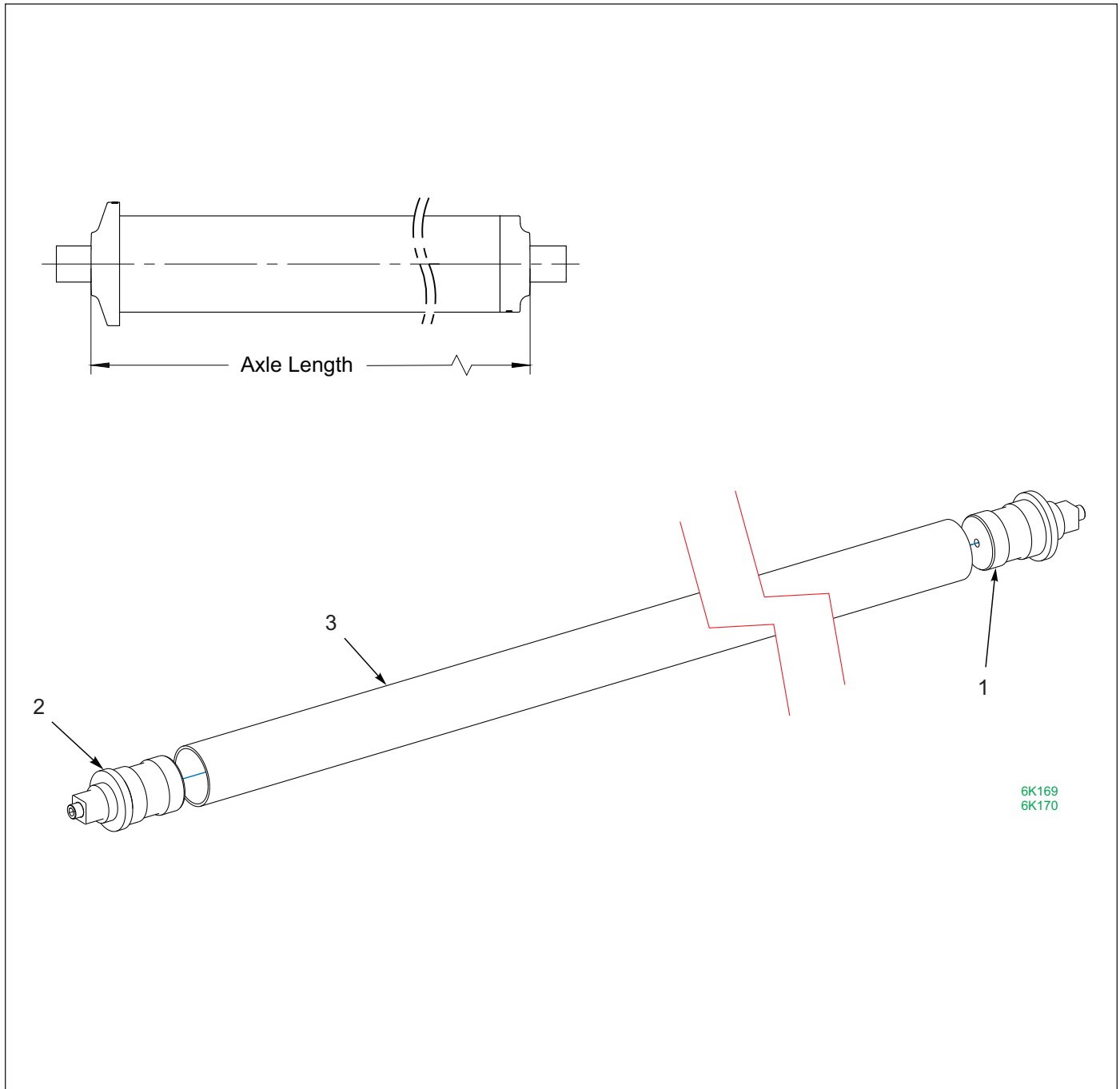

Figure 1-23: Pipe Axle Assembly With Replaceable Stub

### Pipe Axle Assembly With Replaceable Stub

ITEM	PART NUMBER	DESCRIPTION	QUANTITY	
			72"	76"
	6K170	PIPE AXLE REPL STUB,72"	1	--
	6K169	PIPE AXLE REPL STUB,76"	--	1
1	6K190	FLANGED STUB ASSEMBLY (PAGE 1-36)	1	1
2	6K191	STUB ASSEMBLY (PAGE 1-37)	1	1
3	-----	NOT SOLD SEPERATELY, ORDER ASSEMBLY TO REPLACE	1	1

# Flange Stub Assembly

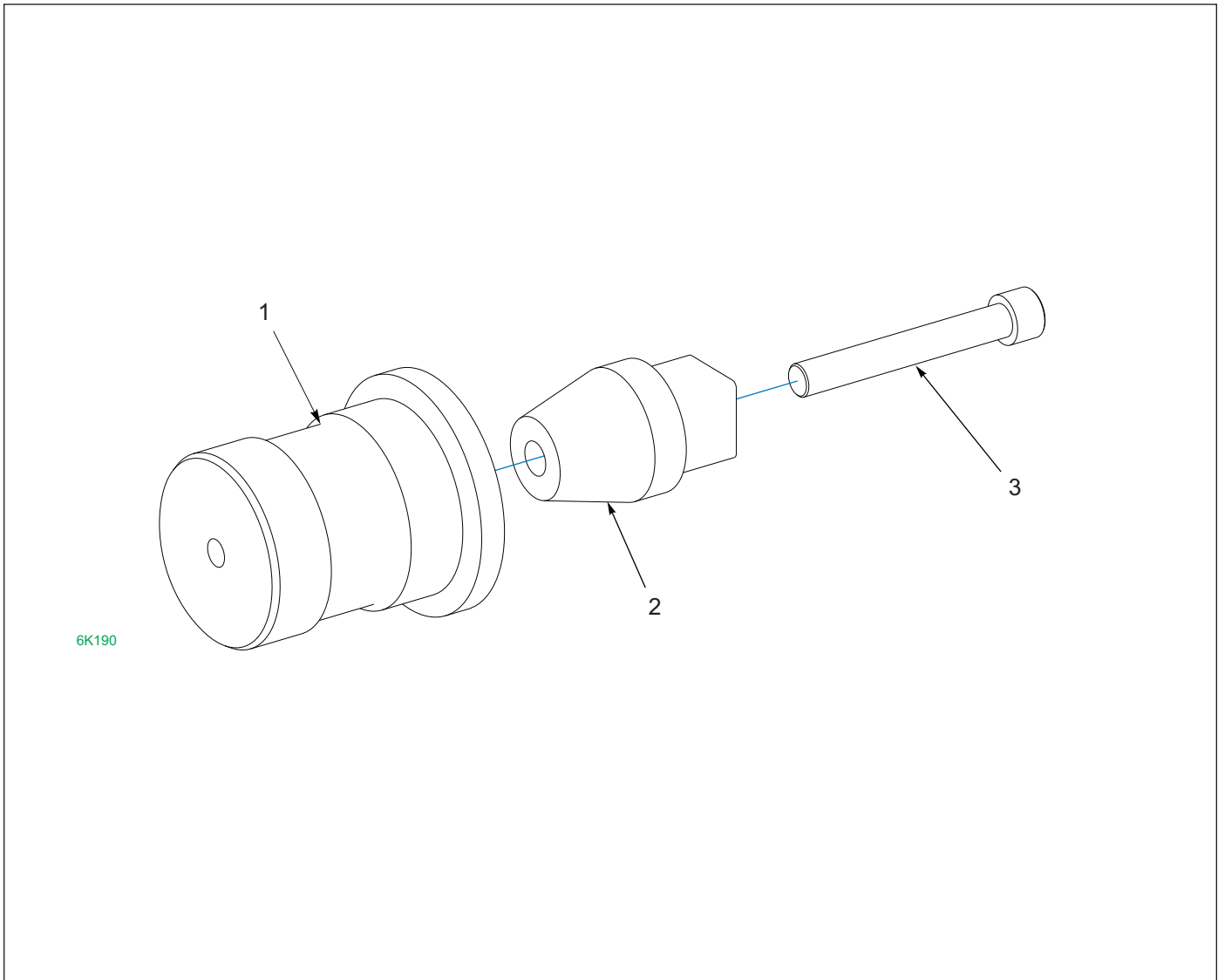

Figure 1-24: Flanged Stub Assembly

## Flanged Stub Assembly

ITEM	PART NUMBER	DESCRIPTION	QTY
	6K190	FLANGED STUB ASSEMBLY	1
1	6K104	FLANGED AXLE STUB	1
2	6K105	SQUARE PLUG	1
3	6K132	HEX SOCKET HEAD CAPSCREW	1



## Stub Assembly

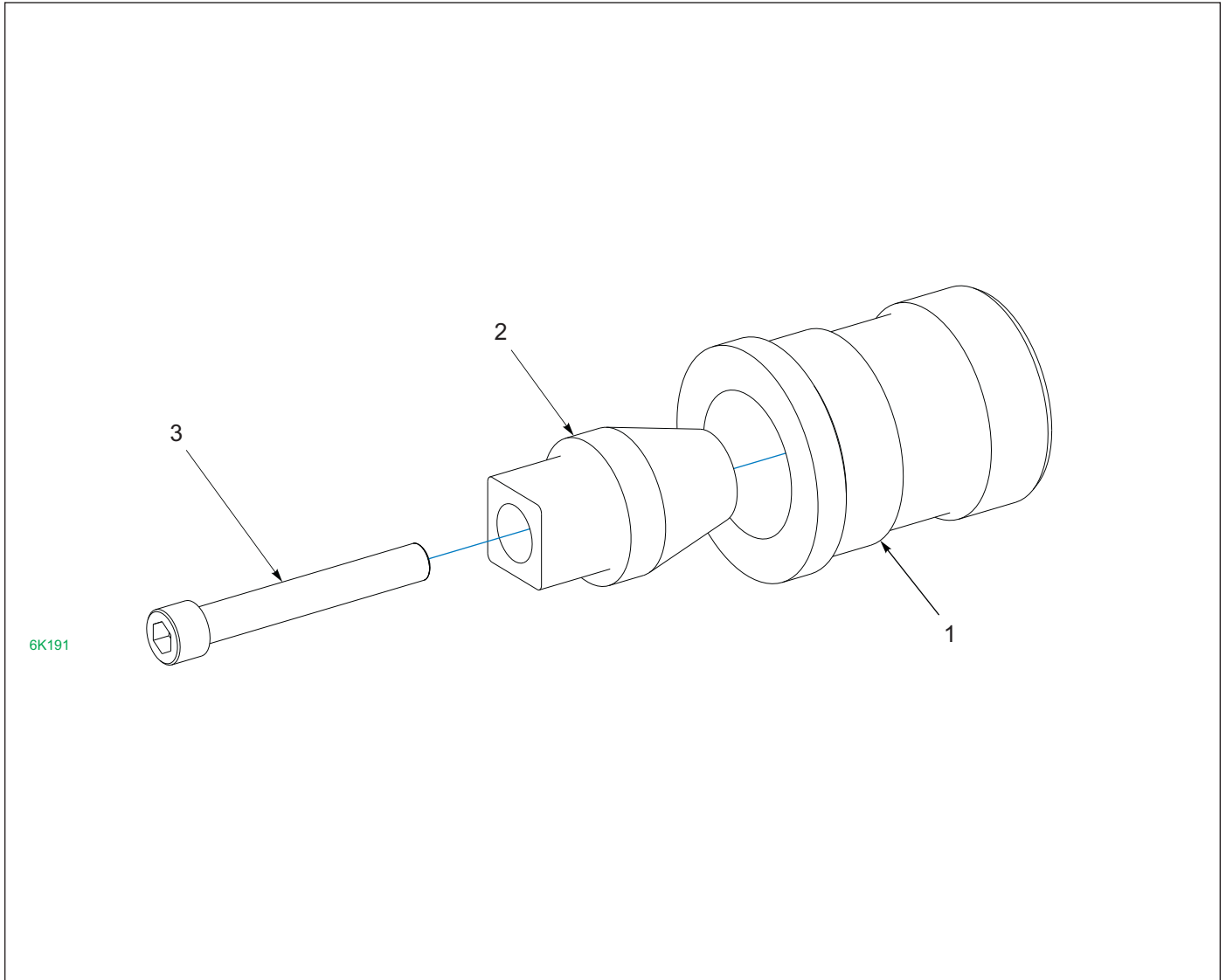

Figure 1-25: Stub Assembly

## Stub Assembly

ITEM	PART NUMBER	DESCRIPTION	QTY
	6K191	STUB ASSEMBLY	1
1	6K103	AXLE STUB	1
2	6K105	SQUARE PLUG	1
3	6K132	HEX SOCKET HEAD CAPSCREW	1

# Hydraulic Diagram (Before 03/01/2003)

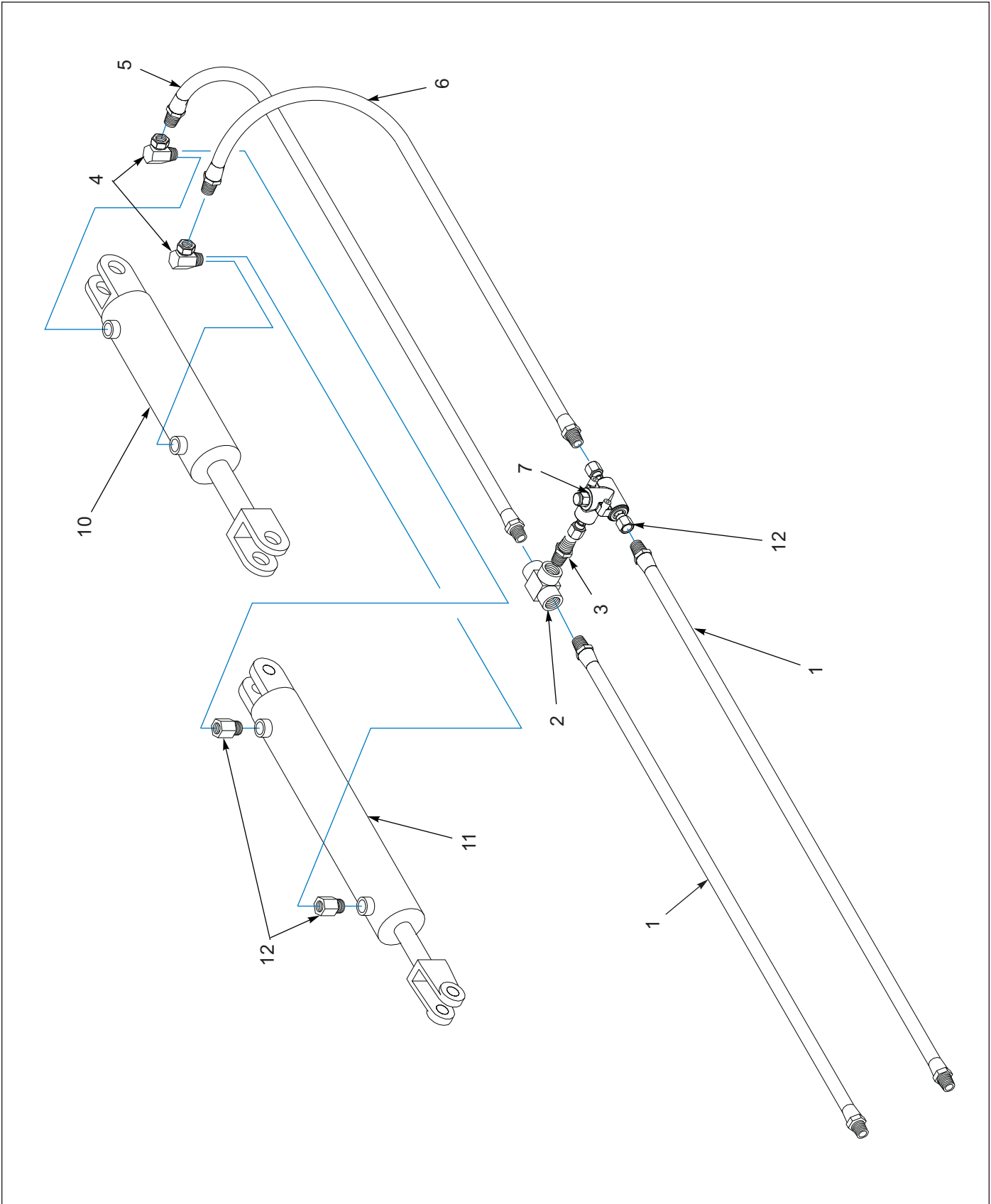

Figure 1-26: Hydraulic Diagram (Before 03/01/2003)

## Hydraulic Diagram (Before 03/01/2003)

ITEM	PART NUMBER	DESCRIPTION	QTY
1	-----	HYDRAULIC HOSE, 251"	2
2	4D982	TEE FITTING	1
3	6D148	HYDRAULIC PIPE NIPPLE	1
4	1J131	90 DEGREE SWIVEL FITTING (OBS)	1
5	-----	HYDRAULIC HOSE, 38"	1
6	-----	HYDRAULIC HOSE, 26"	1
7	8J650	RELIEF VALVE ( <b>APPEARANCE MAY VARY</b> )	1
8	1-861-010034-09	WASHER LOCK 1/4 ZP ( <b>NOT SHOWN</b> )	2
9	1-512-010007-05	NUT, HEX 1/4-20, ZP ( <b>NOT SHOWN</b> )	2
10	9D524	HYD CYLINDER - 3 1/2 X 16 ( <b>PAGE 1-49 AND 1-50</b> )	1
11	4K777	HYD CYL(DEAD)**USE 6K843** ( <b>BEFORE 08/01/2000</b> ) ( <b>PAGE 1-51</b> )	1
11	6K843	HYD CYLINDER - 3 1/2 X 16 ( <b>AFTER 08/01/2000</b> ) ( <b>PAGE 1-53</b> )	1
12	7J026	ADAPTOR *OBS*	5
13	9D851	CABLE TIE - 20" ( <b>NOT SHOWN</b> )	1
14	3J615	CABLE TIE - 28" ( <b>NOT SHOWN</b> )	4

# Hydraulic Diagram

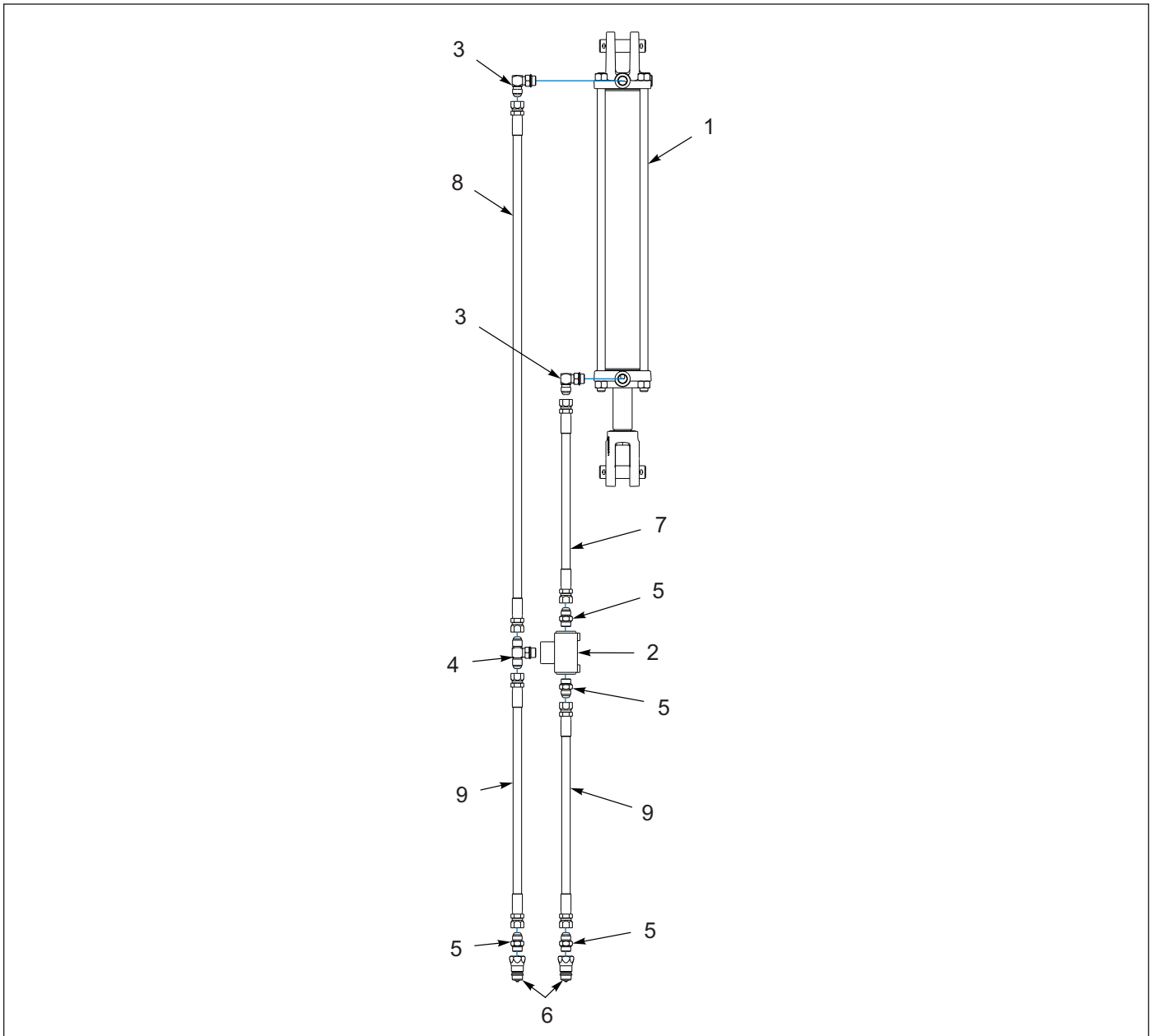

Figure 1-27: Hydraulic Diagram

# Hydraulic Diagram

ITEM	PART NUMBER	DESCRIPTION	QTY
1	6K843	HYD CYLINDER - 3 1/2 X 16 (PAGE 1-56)	1
2	8J650	RELIEF VALVE	1
3	4K603	90 DEGREE APADTER (08MJ X 08MOR X 90°)	2
4	4K861	HYDRAULIC ADAPTER TEE (08MJ X 08MJ X 08MOR BRANCH)	1
5	4K602	STRAIGHT ADAPTER (08MJ X 08MOR)	4
6	4K912	MALE TRACTOR TIP (COUPLING X 08FOR)	2
7	4K881	HYDRAULIC HOSE - 3/8 X 29"	1
8	6K302	HYDRAULIC HOSE - 3/8 X 42"	1
9	5K597	HYDRAULIC HOSE 3/8 X 252	2

### Hydraulic Diagram, Tooth Control

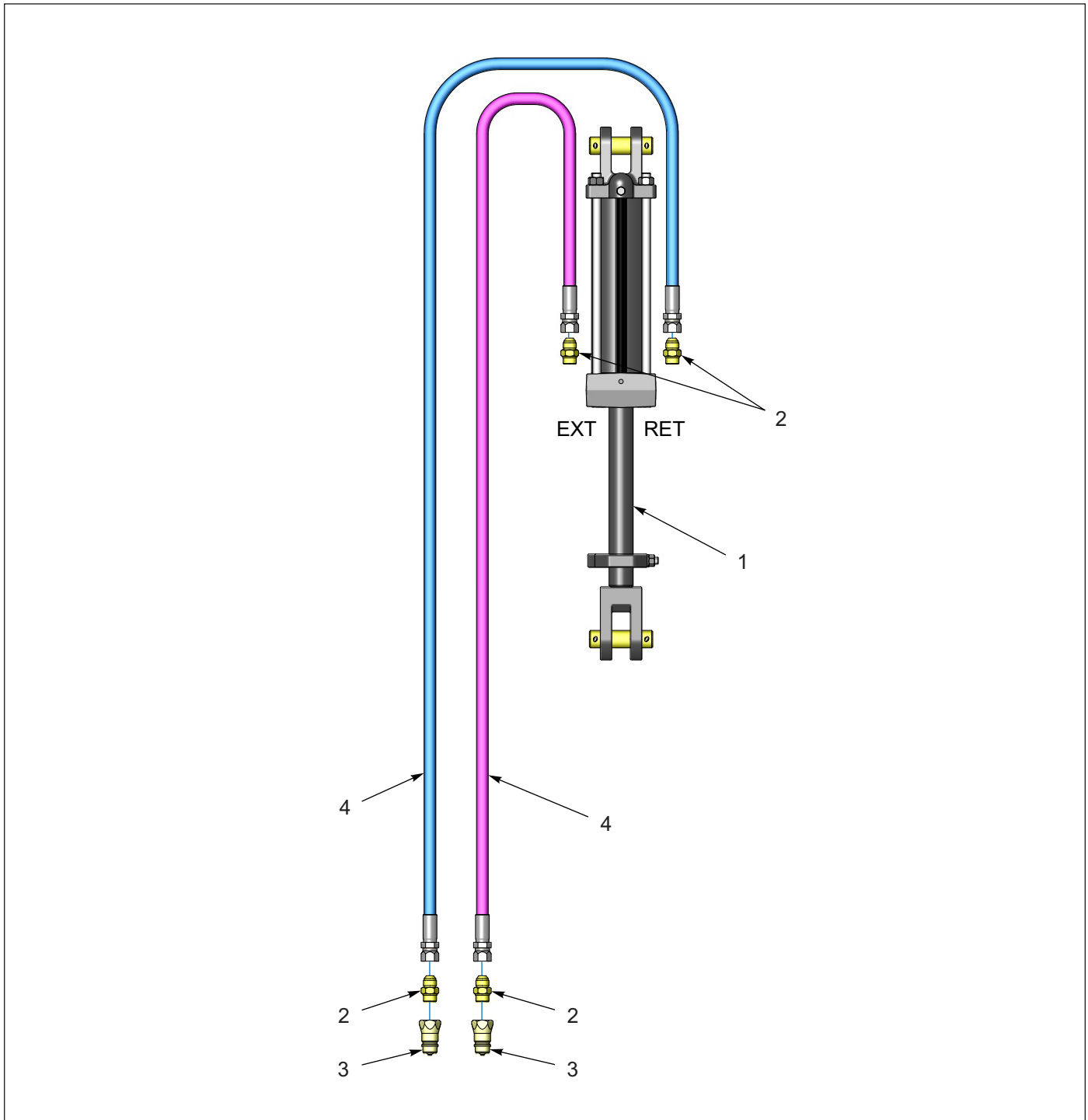

Figure 1-28: Hydraulic Diagram, Tooth Control

### Hydraulic Diagram, Tooth Control

ITEM	PART NUMBER	DESCRIPTION	QTY
1	3J603	HYDRAULIC CYLINDER (3 X 8) (PAGE 1-56)	1
2	4K602	STRAIGHT ADAPTOR (08MJ X 08MOR)	4
3	4K912	MALE TRACTOR TIP	2
4	4K919	HYDRAULIC HOSE - 285"	2

# LED Lights Layout (After 01/01/2017)

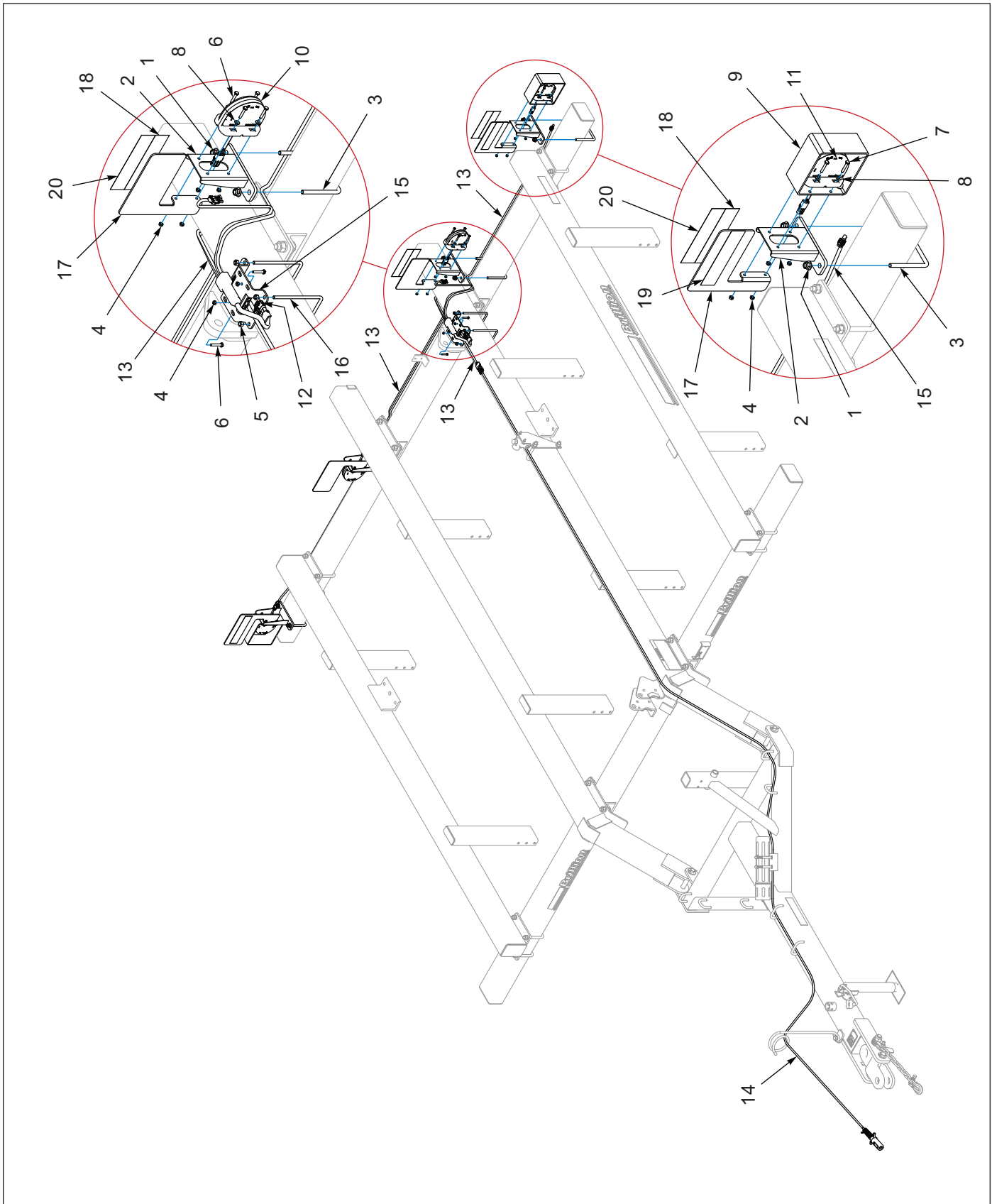

Figure 1-29: LED Lights Layout (After 01/01/2017)

## LED Lights Layout (After 01/01/2017)

ITEM	PART NUMBER	DESCRIPTION	QTY
1	2P253	NUT, FLANGE NY-LOK 1/2-13	8
2	205353	BRACKET WLDMT SINGLE LAMP	4
3	4J918	U-BOLT 1/2-13 X 5-1/4 X 6-1/16	4
4	1-512-010005-01	NUT, HEX SLFLKG GRB 1/4-20	18
5	1-512-010005-05	NUT, HEX SLFLKG GRB 3/8-16	4
6	1-654-010047-08	SCREW, HX CP, 1/4-20UNC X 1-1/2, G5	10
7	1-654-010047-09	SCREW, HX CP, 1/4-20UNC X 1-3/4, G5	8
8	1-861-010032-06	WASHER, FLAT 1/4 N ZP/CD	16
9	164700	TUBE LIGHT SHIELD	2
10	174435	LAMP, AG RED SINGLE LED	2
11	174436	LAMP, AG AMBER SINGLE LED	2
12	174437	MODULE, AG FLASHER CONTROL	1
13	175151	HARNESS, LED WARNING LIGHTS	1
14	175152	HARNESS 7 PIN/4 PIN WP	1
15	178506	BRACKET, MODULE MOUNT	1
16	178529	U-BLT, 3/8-16 X 4-7/16 X 6-7/8, ZP	2
17	199588	BRACKET, REFLECTIVE DECAL	4
18	528933	REFLECTOR - RED	4
19	528934	REFLECTOR - YELLOW	2
20	528938	STRIPE, ORANGE	4
21	105-0228	TY-WRAP 8IN LG TY-52772MX (NOT SHOWN)	24
22	105874	TIE, STRAP PLSTC 21.5-24 X .301(NOT SHOWN)	4

# Lights (Before 01/01/2017)

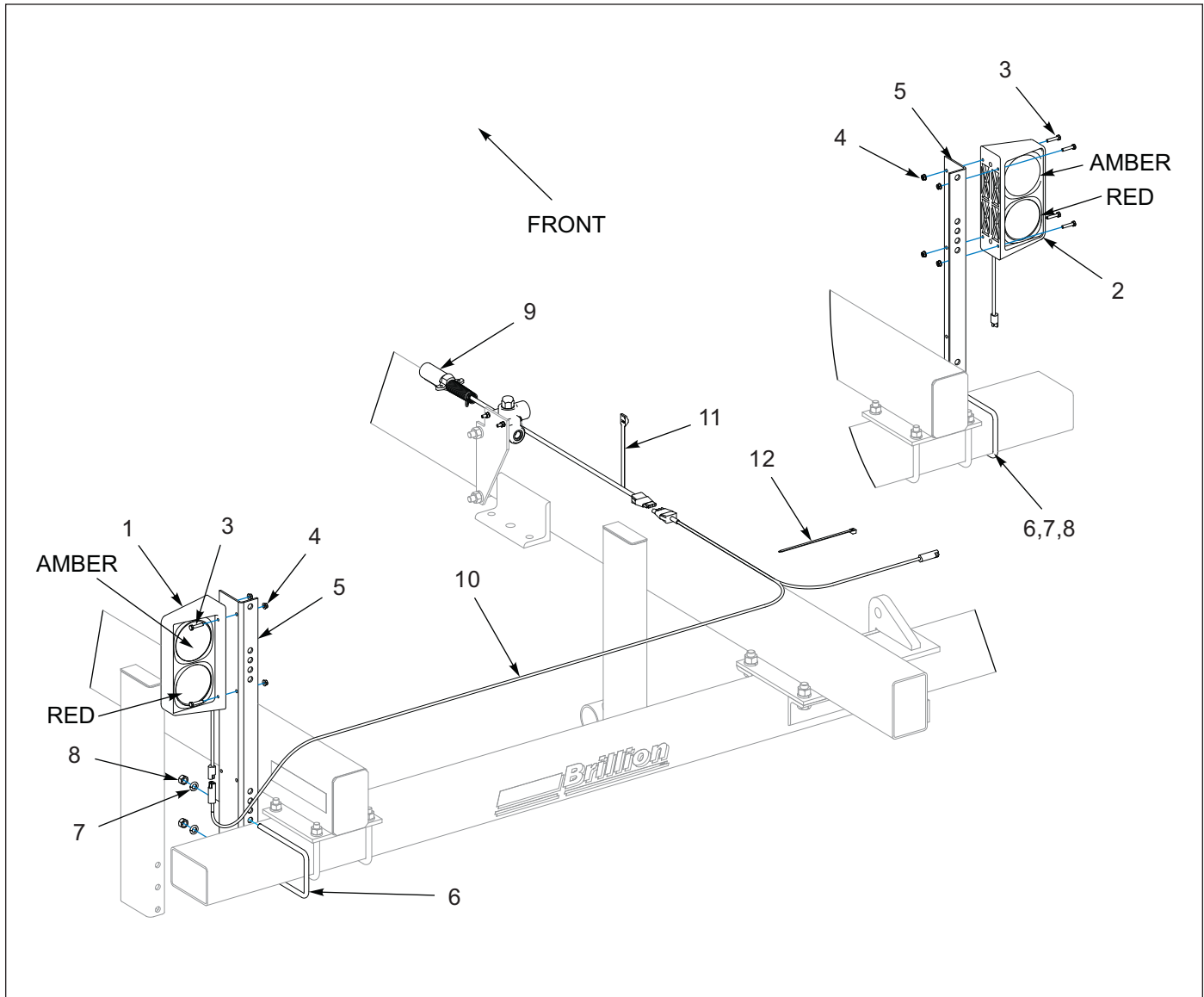

Figure 1-30: Lights (Before 01/01/2017)

# Lights (Before 01/01/2017)

ITEM	PART NUMBER	DESCRIPTION	QTY
1	4K773	RH DUAL LAMP (002601) (INSTALLED ON L.H. SIDE OF MACHINE)	1
2	4K772	LH DUAL LAMP (002600) (INSTALLED ON R.H. SIDE OF MACHINE)	1
3	1-654-010047-07	SCREW, HX CP 1/4-20UNC X 1-1/4, G5	8
4	108417	NUT, SPIRAL LOCK 1/4-20 GRF ZP	8
5	4K774	ANGLE (BRACKET WELDMENT)	2
6	3J561	U-BOLT, 1/2-13 X 7-1/2 X 4-1/2	4
7	1-861-010034-13	WASHER, LOCK 1/2, ZP	8
8	1-512-010007-09	NUT, HEX 1/2-13, ZP	8
9	4K800	AG HARNESS - 30' (002430)	1
10	4K780	10' WISHBONE AG HARNESS (2510)	1
11	9D674	HOSE TIE - 8"	10
12	9D851	CABLE TIE - 20"	4



### Scrape Kit, Optional Front and Standard on Rear

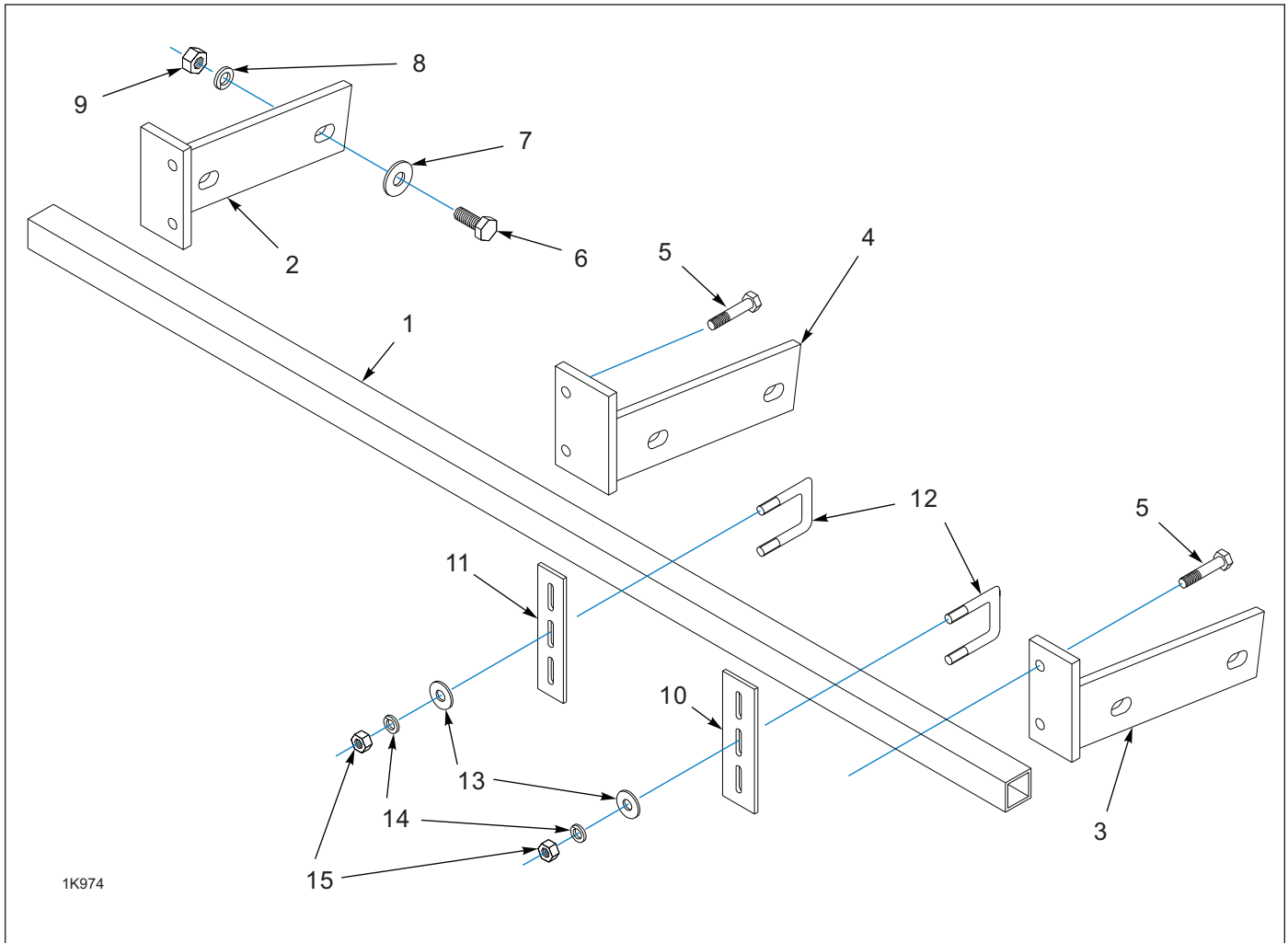

Figure 1-31: Scrape Kit, Optional Front and Standard on Rear

### Scrape Kit, Optional Front and Standard on Rear

ITEM	PART NUMBER	DESCRIPTION	QTY
	1K974	FRONT SCRAPER	1
1	1K959	SCRAPER TUBE (231" LONG)	1
2	9J581	L.H. SCRAPER BRKT.	1
3	9J582	R.H. SCRAPER BRKT.	1
4	9J584	SCRAPER BRKT	2
5	1-654-010051-15	SCREW, HXCP 3/8-16UNC X 3-1/2, G5	8
6	1-654-010055-04	SCREW, HEX CAP 1/2-13UNC X 1-3/4	8
7	1-861-010032-15	WASHER, FLAT 1/2 W ZP/CD	8
8	1-861-010034-13	WASHER, LOCK 1/2 ZP	8
9	1-512-010007-09	NUT, HEX 1/2-13, ZP	8
10	8J014	SCRAPER, 2-1/2" WIDE	52
11	9J588	SCRAPER, 2" WIDE	6
12	8J015	U-BOLT, 3/8-16 X 3-1/4 X 2-7/16	54
13	1-861-010032-11	WASHER, FL 3/8 ST,D ZP	116
14	1-861-010034-11	WASHER, LOCK 3/8, ZP	116
15	1-512-010007-07	NUT HEX 3/8-16, ZP	116

## Rear Hitch - Optional

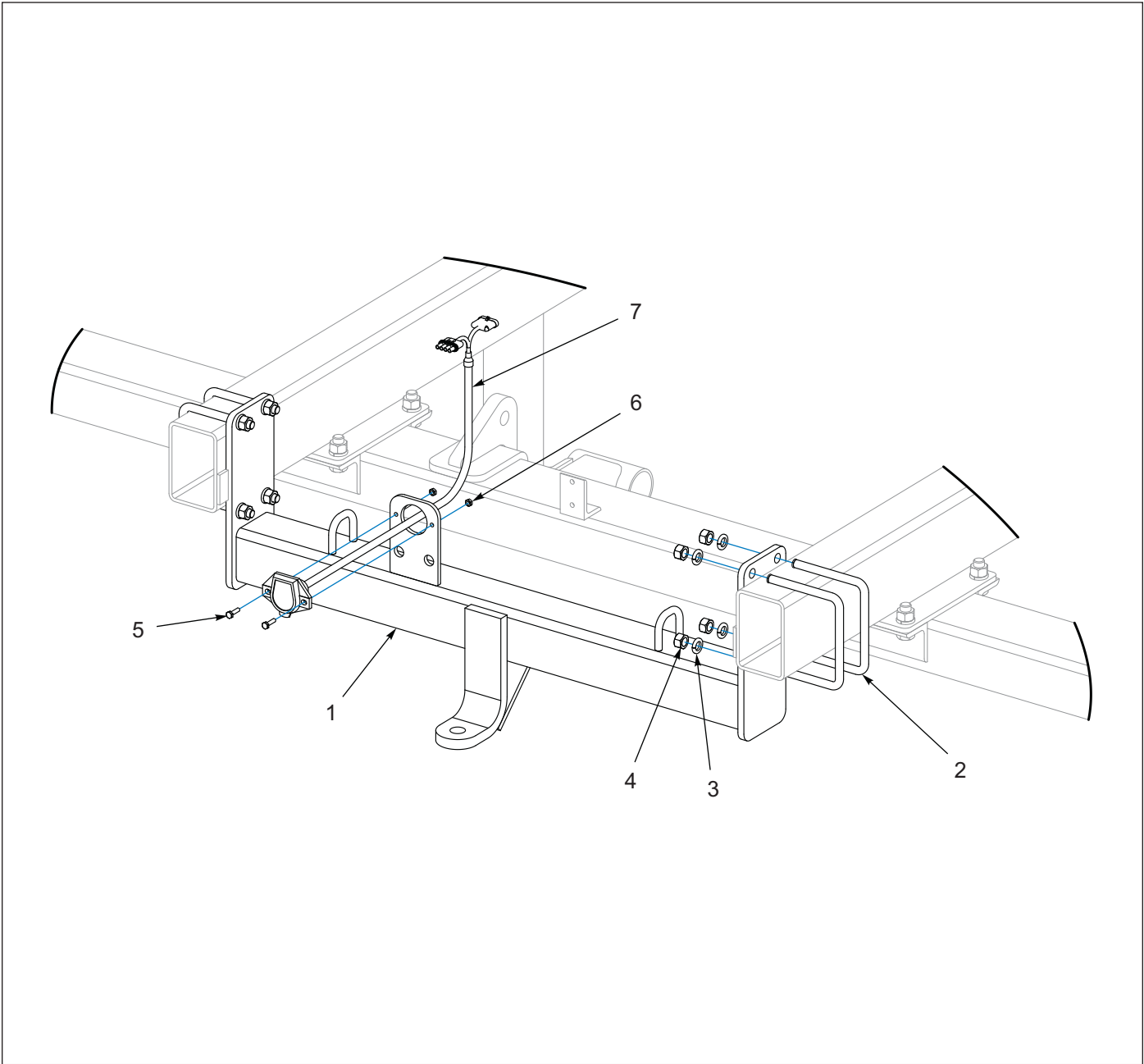

Figure 1-32: Rear Hitch - Optional

## Rear Hitch - Optional

ITEM	PART NUMBER	DESCRIPTION	QTY
	8J127	ML REAR HITCH KIT	1
1	8J051	REAR HITCH	1
2	7J990	U-BOLT, 5/8-11 X 5-1/2 X 6-11/16	4
3	1-861-010034-15	WASHER, 5/8 SLW	8
4	1-512-010007-11	NUT, HEX 5/8-11, ZP	8
5	1-654-010047-06	HHCS, 1/4-20 X 1	2
6	1-512-010005-01	NUT, LOCK 1/4-20	2
7	143871	HARNESS, TANDEM ADAPTER	1

# Land Leveler Kit - Optional

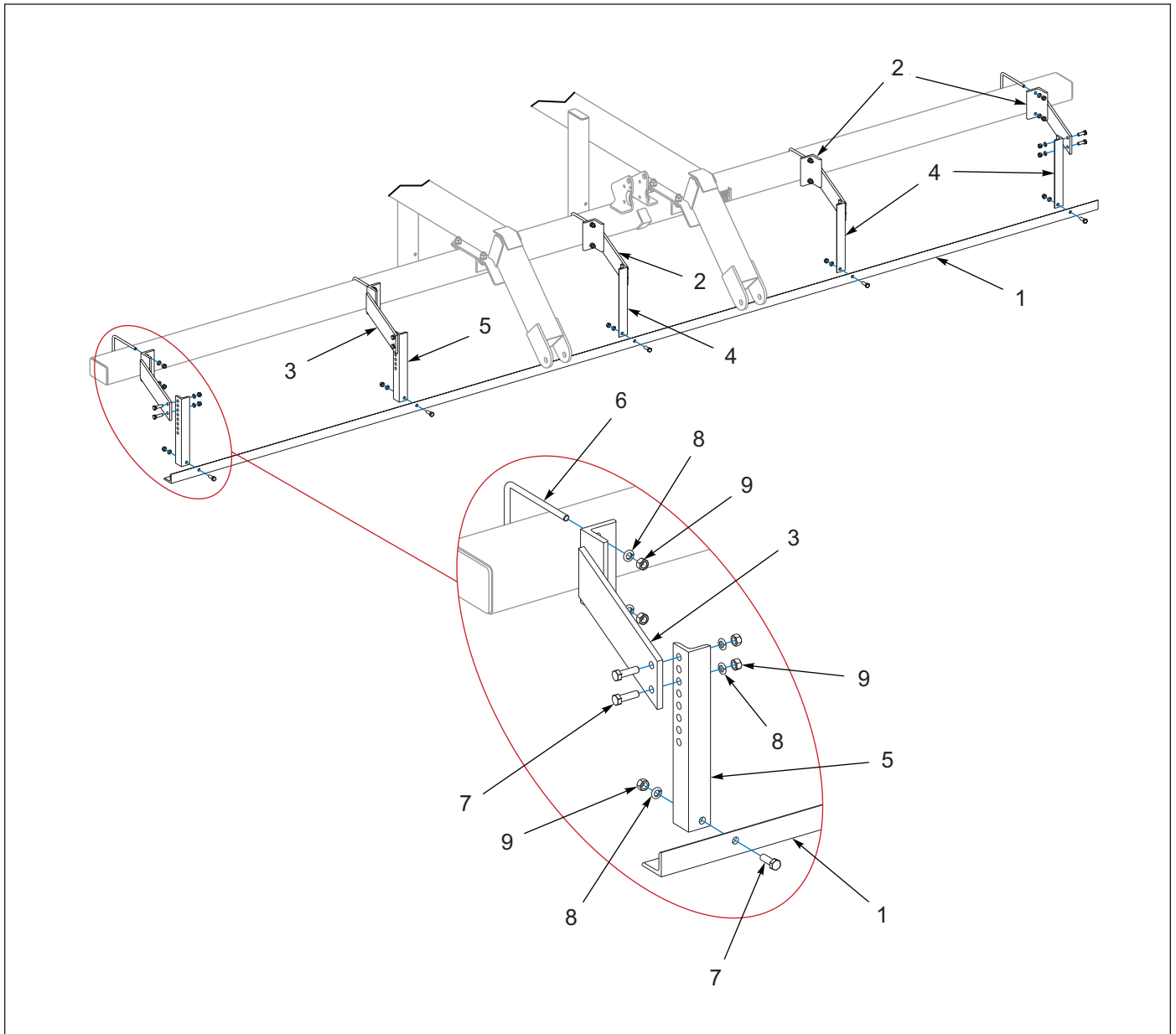

Figure 1-33: Land Leveler Kit - Optional

## Land Leveler Kit - Optional

ITEM	PART NUMBER	DESCRIPTION	QTY
	1K973	LAND LEVELER	1
1	1K972	LEVELER ANGLE (225")	1
2	3J552	BRACKET-L.H.	3
3	3J551	BRACKET-R.H.	2
4	3J557	ADJ. ANGLE-L.H.	3
5	3J556	ADJ. ANGLE-R.H.	2
6	3J561	U-BOLT, 1/2-13 X 7-1/2 X 4-1/2	5
7	1-654-010055-03	SCREW, HEX CAP, 1/2-13UNC X 1-1/2	15
8	1-861-010034-13	WASHER, LOCK 1/2, ZP	25
9	1-512-010007-09	NUT, HEX 1/2-13, ZP	25

## V-Leveler Kit - Optional

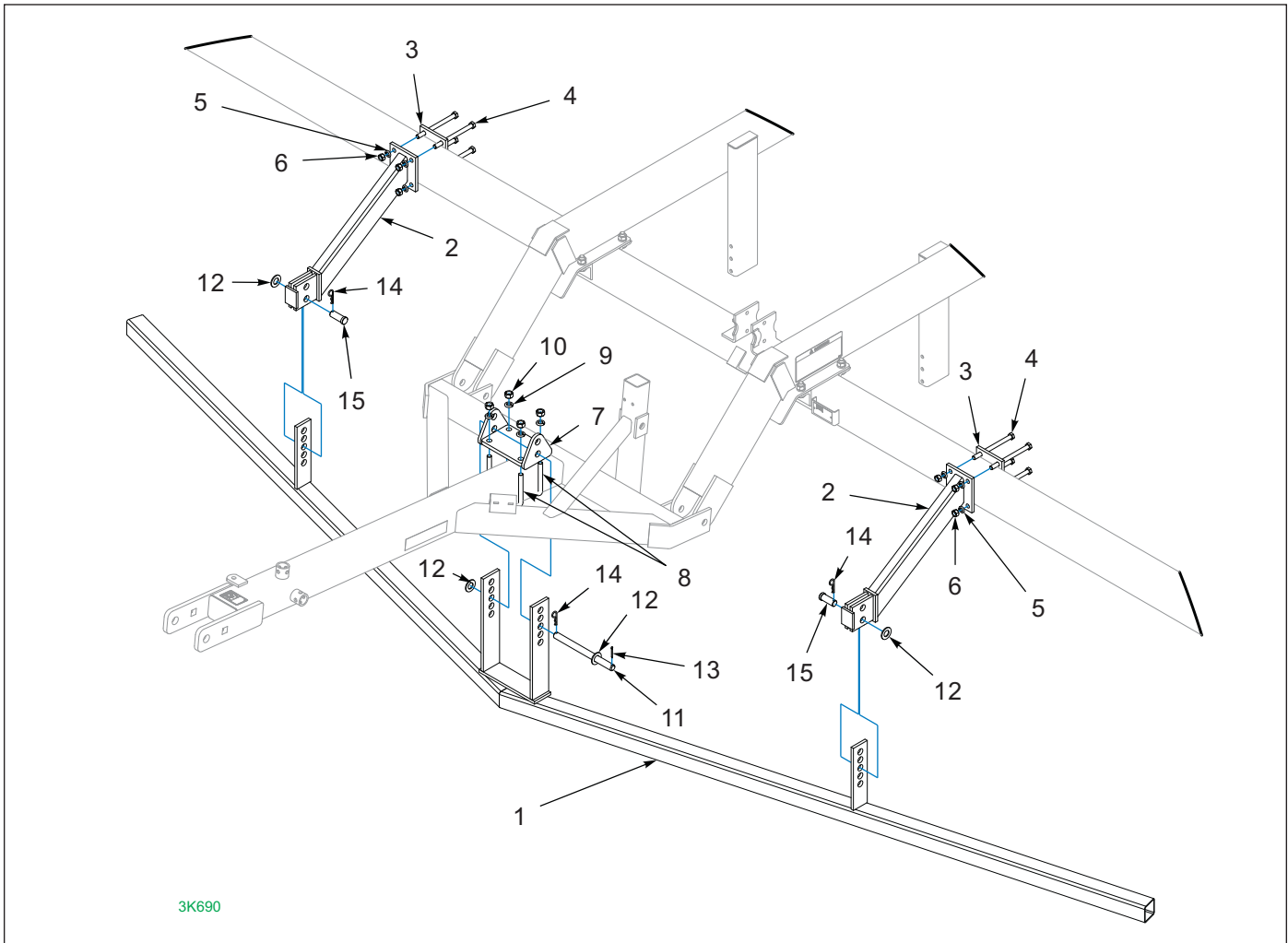

Figure 1-34: V-Leveler Kit - Optional

## V-Leveler Kit - Optional

ITEM	PART NUMBER	DESCRIPTION	QTY
	3K690	V-LEVELER KIT - ML225	1
1	3K684	LEVELER - ML225	1
2	3K678	ARM WELDMENT	2
3	3K693	PLATE	2
4	1-654-010059-21	SCREW, HEX CAP, 5/8-11UNC X 8, GR5	8
5	1-861-010034-15	WASHER, 5/8 SLW	8
6	1-512-010007-11	NUT, HEX 5/8-11, ZP	8
7	3K683	BRACKET	1
8	3J450	U-BOLT, 3/4-10 X 6 X 4	2
9	1-861-010034-17	WASHER, LKG, HLCL SPR, 3/4	4
10	1-512-010007-12	NUT HEX 3/4-10, ZP	4
11	3K694	PIN (1 X 12.5)	1
12	1-861-010032-24	1" SAE FLAT WASHER	4
13	1C205	COTTER PIN 5/32 X 1-1/2	1
14	4C856	HAIR PIN COTTER	3
15	5D012	CLEVIS PIN	2

# Hydraulic Cylinder, 3-1/2 x 16 (Before 08/01/1997) - Hydraulic Gear

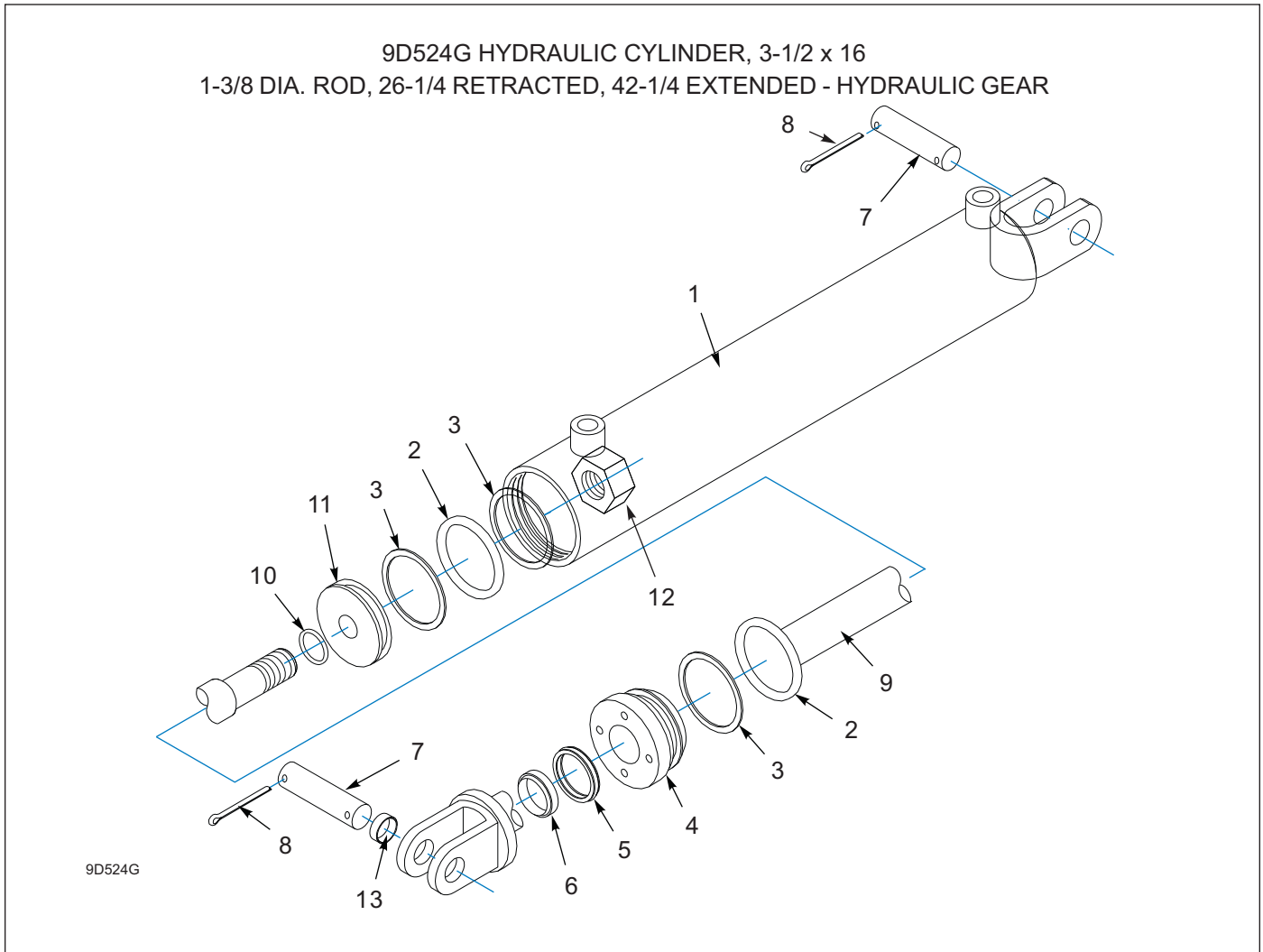

Figure 1-35: Hydraulic Cylinder, 3-1/2 x 16 (Before 08/01/1997) - Hydraulic Gear

# Hydraulic Cylinder, 3-1/2 x 16 (Before 08/01/1997) - Hydraulic Gear

ITEM	PART NUMBER	DESCRIPTION	QTY
	9D524	HYD CYLINDER - 3 1/2 X 16	1
1	-----	TUBE ASSEMBLY	1
2	-----	O-RING	2
3	-----	BACK-UP RING	3
4	-----	GLAND	1
5	-----	ROD SEAL AND BACK UP RINGS	1
6	-----	WIPER	1
7	5J650	CLEVIS PIN	2
8	110-4224	PIN, COTTER 3/16 X 2 IN LG	4
9	-----	ROD ASSEMBLY	1
10	-----	O RING	1
11	-----	PISTON	1
12	-----	HEX NUT 7/8-14 NF LOCK	1
13	8J918	TENSION BUSHING	2
14	1J961	SEAL KIT (INCLUDES ITEMS 2,3,5,6, AND 10)	REF

### Hydraulic Cylinder, 3-1/2 x 16 (Before 08/01/1997) - Lion

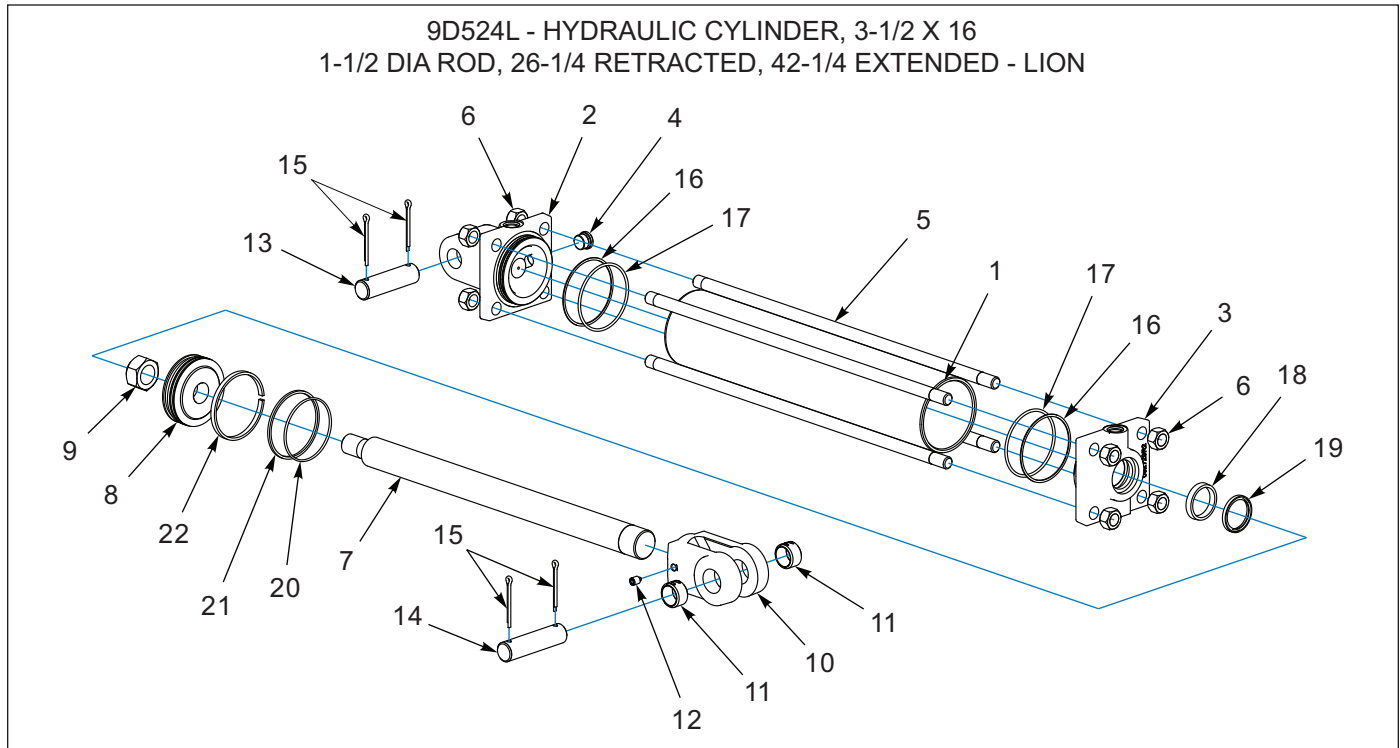

Figure 1-36: Hydraulic Cylinder, 3-1/2 x 16 (Before 08/01/1997) - Lion

### Hydraulic Cylinder, 3-1/2 x 16 (Before 08/01/1997) - Lion

ITEM	PART NUMBER	DESCRIPTION	QTY
	9D524	HYD CYLINDER - 3 1/2 X 16	1
1	-----	TUBE	1
2	-----	CLEVIS CAP	1
3	-----	ROD CAP	1
4	-----	PLUG, SOCKET HEAD 3/4-16	4
5	-----	TIE ROD	1
6	-----	NUT, HEX 5/8-18, ZP	8
7	-----	ROD	1
8	-----	PISTON	1
9	-----	NUT, LOCK 1-14, GRB, ZP	1
10	2P740	CLEVIS, ROD END FOR 1 1/2" RO (INCLUDES ITEMS 11 AND 12)	1
11	3P079	SPRING BUSHING,1.0 X 1.25 X 0.75	2
12	1P443	SET SCREW, 3/8-16 X 1/2 NYL	1
13	5J650	CLEVIS PIN (1.0 X 3.625 H2)	1
14	7J067	CLEVIS PIN (1.0 X 4.0 H2)	1
15	110-4224	PIN, COTTER 3/16 X 2 IN LG	4
16	-----	SEAL,BU#236 19PI-236	2
17	-----	O-RING, 236 (3.25 X 3.5) D90	2
18	-----	SEAL, HALLITE 605 ROD 1-1/2 D	1
19	-----	SEAL, NOK-AR2263-EO 1-1/2"BO	1
20	-----	O-RING, 151 (3.0X3.188) DUR90	1
21	-----	SEAL, PTFE PISTON RING 3-1/2D	1
22	-----	WEAR RING,3.50-3.25-.25-GFN	1
23	1P744	LION CYLINDER SEAL KIT (3.5") (INCLUDES ITEMS 16-22)	REF

### Hydraulic Cylinder, 3-1/2 x 16 (Before 08/01/2000)

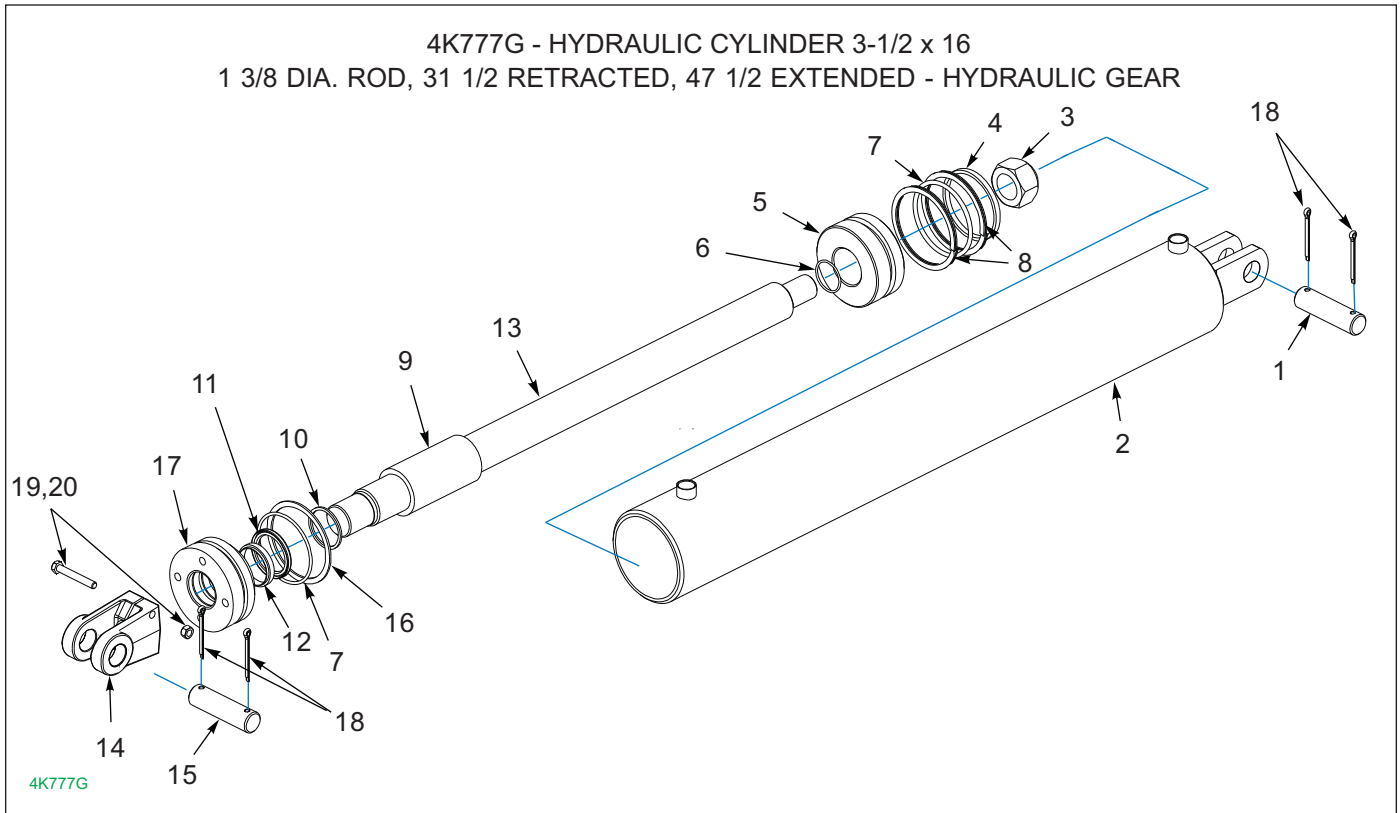

Figure 1-37: Hydraulic Cylinder, 3-1/2 x 16 (Before 08/01/2000)

### Hydraulic Cylinder, 3-1/2 x 16 (Before 08/01/2000)

ITEM	PART NUMBER	DESCRIPTION	QTY
	4K777	HYD CYL - 3 1/2 X 16	1
1	5J650	CLEVIS PIN	1
2	-----	TUBE ASSY FOR 4K777G CYL	1
3	-----	LOCK NUT, 1-14	1
4	-----	WEAR RING	1
5	-----	PISTON FOR 4K777G CYL	1
6	-----	O-RING	1
7	-----	O-RING	2
8	-----	SPRING BACKUP	2
9	-----	SPACER FOR 4K777G CYL	1
10	-----	WEAR RING	1
11	-----	O-RING	1
12	-----	WIPER	1
13	-----	ROD FOR 4K777G CYL	1
14	5J195	CLEVIS (7000215)	1
15	-----	CLEVIS	1
16	-----	BACKUP RING	1
17	-----	PACKING GLAND	1
18	110-4224	PIN, COTTER 3/16 X 2 IN LG	4
19	1-654-010049-11	SCREW HX CAP 5/16-18UNC X 2 1/2 GR5	1
20	104032	NUT NY-LOCK 5/16-18 ZP	1
21	5K793	SEAL KIT FOR 4K777G CYL (INCLUDES ITEMS 4,6-8,10-12, AND 16)	REF

### Hydraulic Cylinder, 3-1/2 x 16 (Used 08/01/2000 to 01/15/2008)

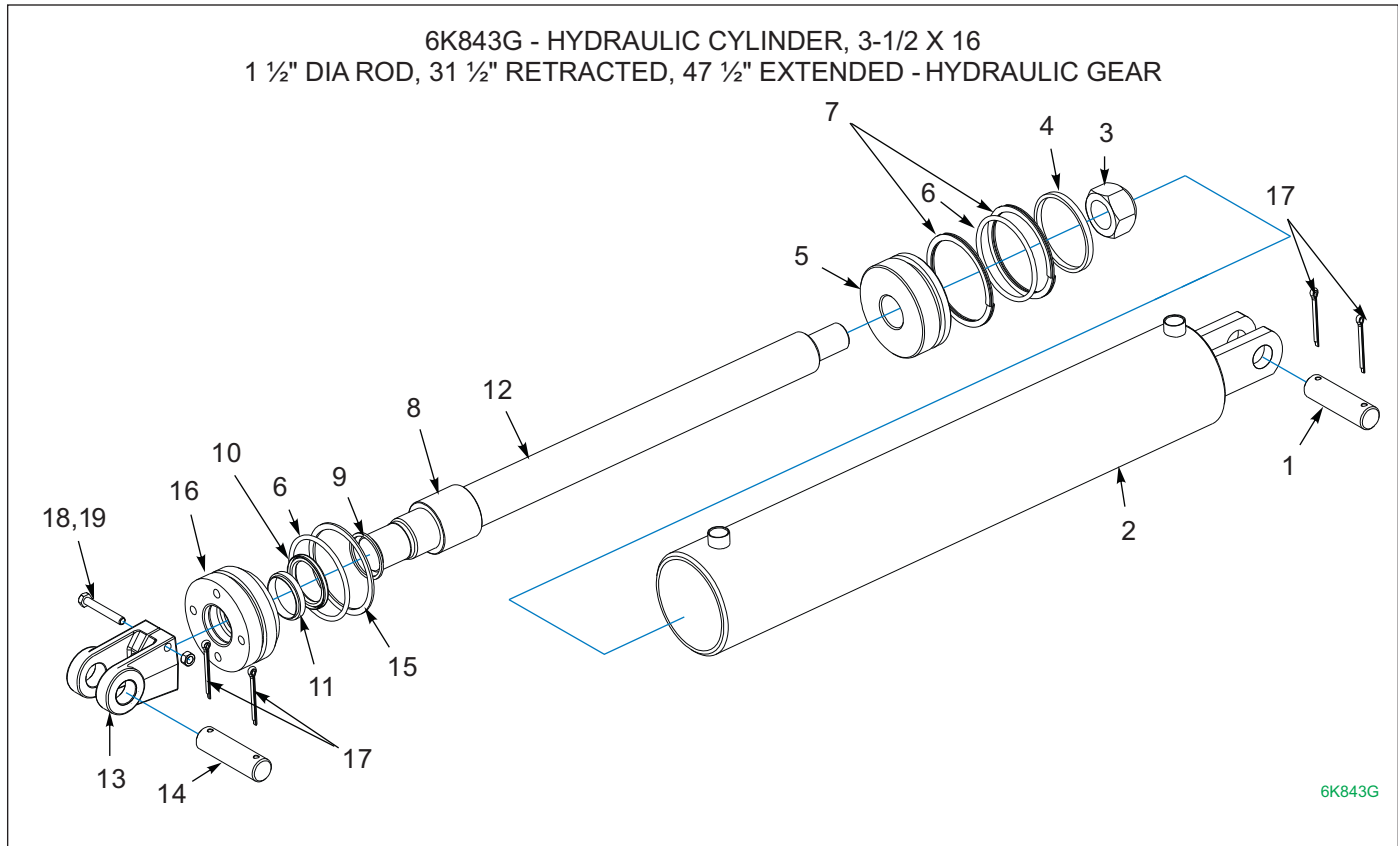

Figure 1-38: Hydraulic Cylinder, 3-1/2 x 16 (Used 08/01/2000 to 01/15/2008)

### Hydraulic Cylinder, 3-1/2 x 16 (Used 08/01/2000 to 01/15/2008)

ITEM	PART NUMBER	DESCRIPTION	QTY
	6K843	HYD CYLINDER - 3 1/2 X 16	1
1	5J650	CLEVIS PIN	1
2	-----	TUBE ASSEMBLY	1
3	-----	LOCK NUT, 1-14	1
4	-----	WEAR RING	1
5	-----	PISTON	1
6	-----	O-RING	1
7	-----	SPIRAL TEFLON BACKUP	2
8	-----	SPACER FOR 6K843G CYLINDER	1
9	-----	WEAR RING	1
10	-----	POLYSEAL	1
11	-----	WIPER	1
12	-----	ROD	1
13	5J195	CLEVIS (7000215)	1
14	-----	PIN	1
15	-----	BACKUP RING	1
16	-----	PACKING GLAND FOR 6K843G *OBS*	1
17	110-4224	PIN,COTTER 3/16 X 2 IN LG	4
18	1-654-010049-11	SCREW, HX CP 5/16-18UNC X 2 1/2	1
19	104032	NUT NY-LOCK 5/16-18 ZP	1
20	7K260	SEAL KIT FOR 6K834G CYLINDER (INCLUDES ITEMS 4,6,7,9-11, AND 15)	REF



### Hydraulic Cylinder, 3-1/2 x 16 (After 01/15/2008)

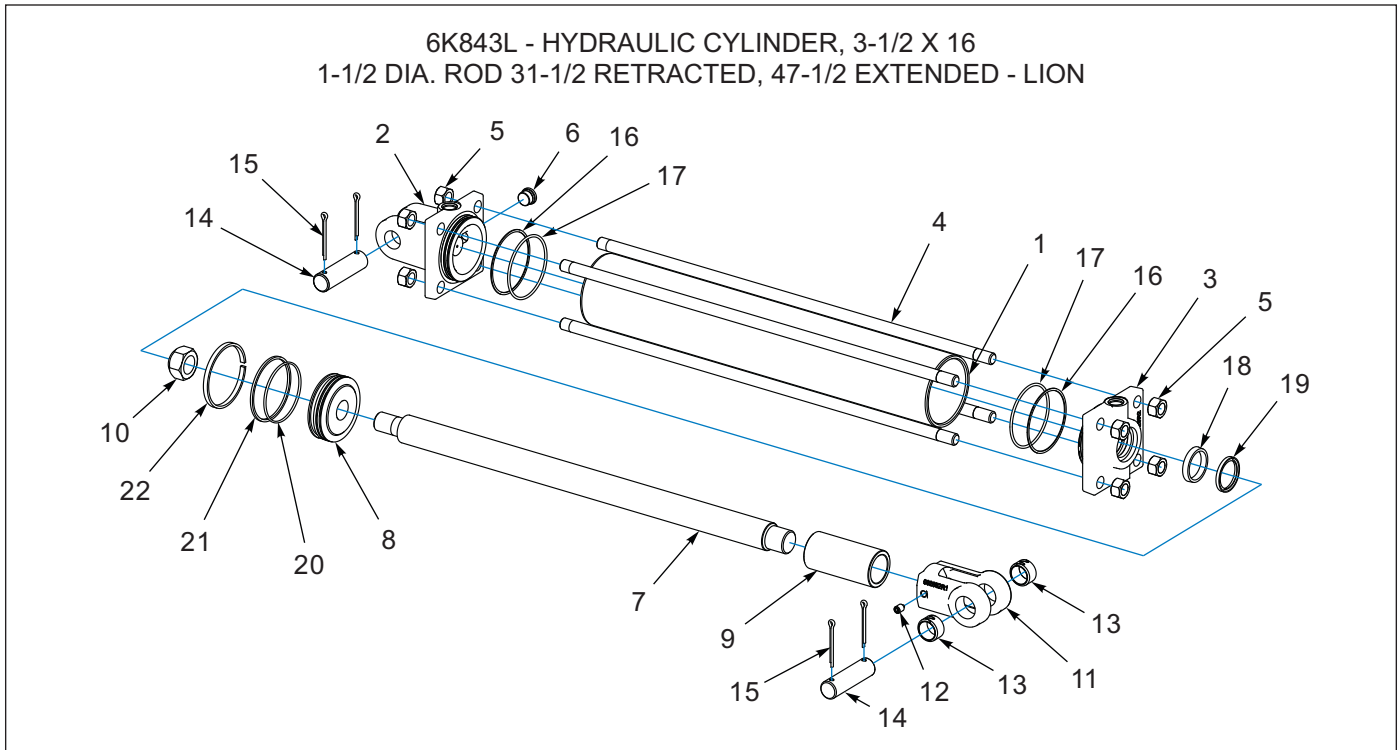

Figure 1-39: Hydraulic Cylinder, 3-1/2 x 16 (After 01/15/2008)

### Hydraulic Cylinder, 3-1/2 x 16 (After 01/15/2008)

ITEM	PART NUMBER	DESCRIPTION	QTY
	6K843	HYD CYLINDER - 3 1/2 X 16	1
1	-----	TUBE	1
2	-----	CLEVIS CAP	1
3	-----	ROD CAP	1
4	-----	TIE ROD	4
5	-----	NUT, HEX 5/8-18, ZP	8
6	-----	PLUG, SOCKET HEAD 3/4-16	1
7	-----	ROD	1
8	-----	PISTON	1
9	-----	STOP TUBE	1
10	-----	NUT, LOCK 1-14, GRB, ZP	1
11	2P111	CLEVIS, ROD END FOR 1 1/2" RO (INCLUDES ITEMS 12,13)	1
12	1P443	SET SCREW, 3/8-16 X 1/2 NYL (NOT SHOWN)	1
13	3P079	SPRING BUSHING, 1.0X1.25X0.75	2
14	5J650	CLEVIS PIN (1.0 X 3.625 H2)	2
15	110-4224	PIN, COTTER-3/16 X 2IN LG	4
16	-----	SEAL, BU#236 19PI-236	2
17	-----	O-RING, 236 (3.25X3.5) D90	2
18	-----	SEAL, HALLITE 605 ROD 1/12 D	2
19	-----	SEAL, NOK-AR2263-EO 1-1/2" BO	1
20	-----	O-RING, 151 (3.0X3.188) DUR90	1
21	-----	SEAL, PTFE PISTON RING 3-1/2D	1
22	-----	WEAR RING, 3.50-3.25-.25-GFN	1
23	1P744	LION CYLINDER SEAL KIT (3.5") (INCLUDES ITEMS 16-22)	REF

# Hydraulic Cylinder, 3 x 8 - Cross

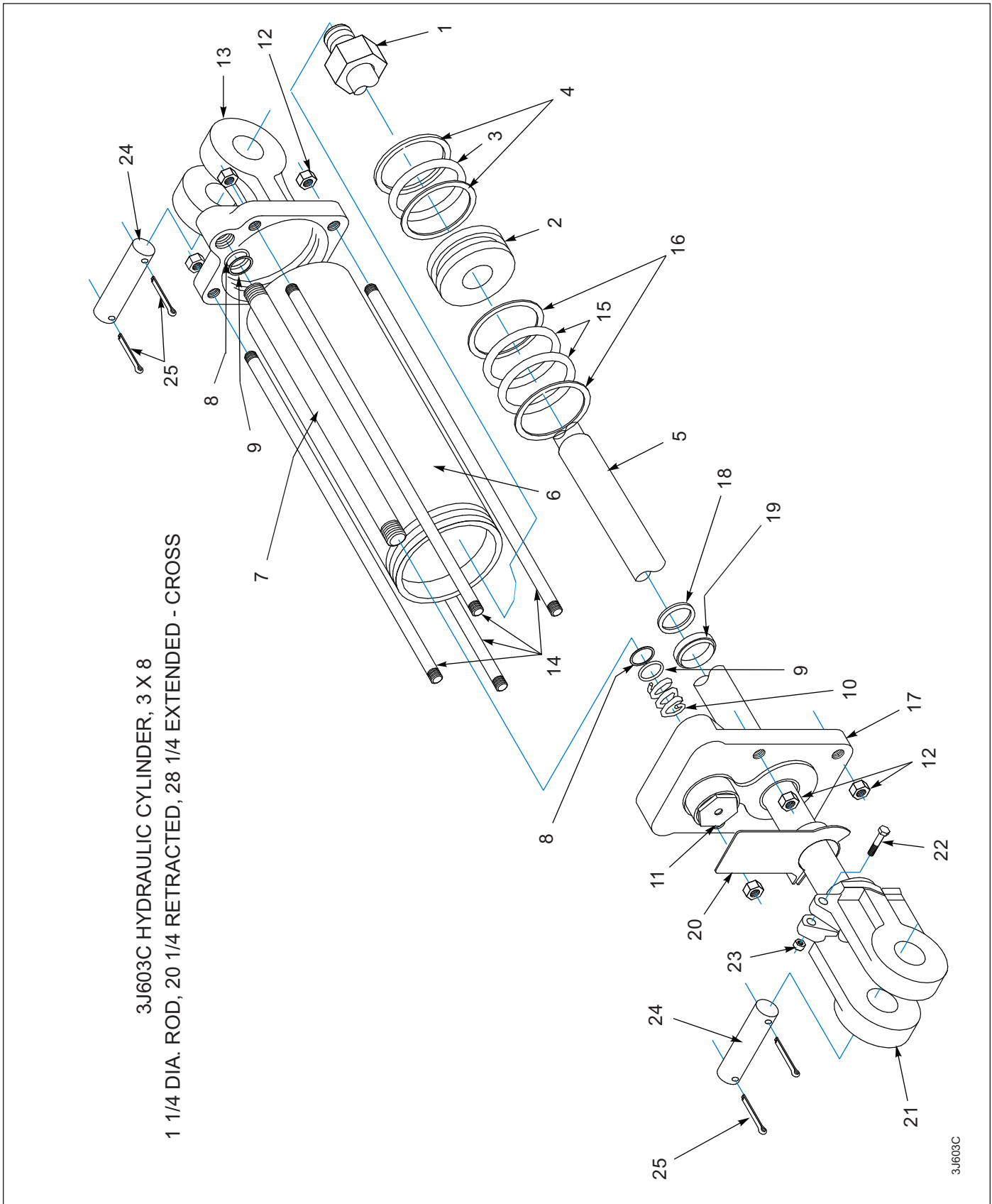

Figure 1-40: Hydraulic Cylinder, 3 x 8 - Cross

## Hydraulic Cylinder, 3 x 8 - Cross

ITEM	PART NUMBER	DESCRIPTION	QTY
	3J603	HYDRAULIC CYLINDER - 3 X 8 (CHECK CYLINDER, C = CROSS)	1
1	5K684	NUT	1
2	5K685	PISTON FOR 3J603C	1
3	-----	O-RING	1
4	-----	BACK-UP RING	2
5	5K686	ROD FOR 3J603C	1
6	5K687	TUBE	1
7	5K688	FEED TUBE	1
8	-----	BACK-UP RING	2
9	-----	O-RING	2
10	5K689	SPRING	1
11	5K690	CART. ASSEMBLY (OBS)	1
12	5K691	NUT	8
13	5K692	BASE CLEVIS	1
14	5K693	TIE ROD	4
15	-----	O-RING	2
16	-----	BACK-UP RING	2
17	5K694	HEAD	1
18	-----	U-CUP	1
19	-----	WIPER	1
20	5K695	ACT. ASSEMBLY	1
21	5K696	ROD CLEVIS	1
22	5K697	CAPSCREW	1
23	5K698	NUT	1
24	7J067	CLEVIS PIN (1 X 4)	2
25	110-4224	PIN,COTTER 3/16 X 2 IN LG	4
26	5K699	SEAL KIT (INCLUDES ITEMS 3,4,8,9,15,16,18, AND 19)	REF

# Hydraulic Cylinder, 3 x 8 - Prince

3J603P - HYDRAULIC CYLINDER, 3 X 8

1 1/4 DIA. ROD, 20 1/4 RETRACTED, 28 1/4 EXTENDED - PRINCE

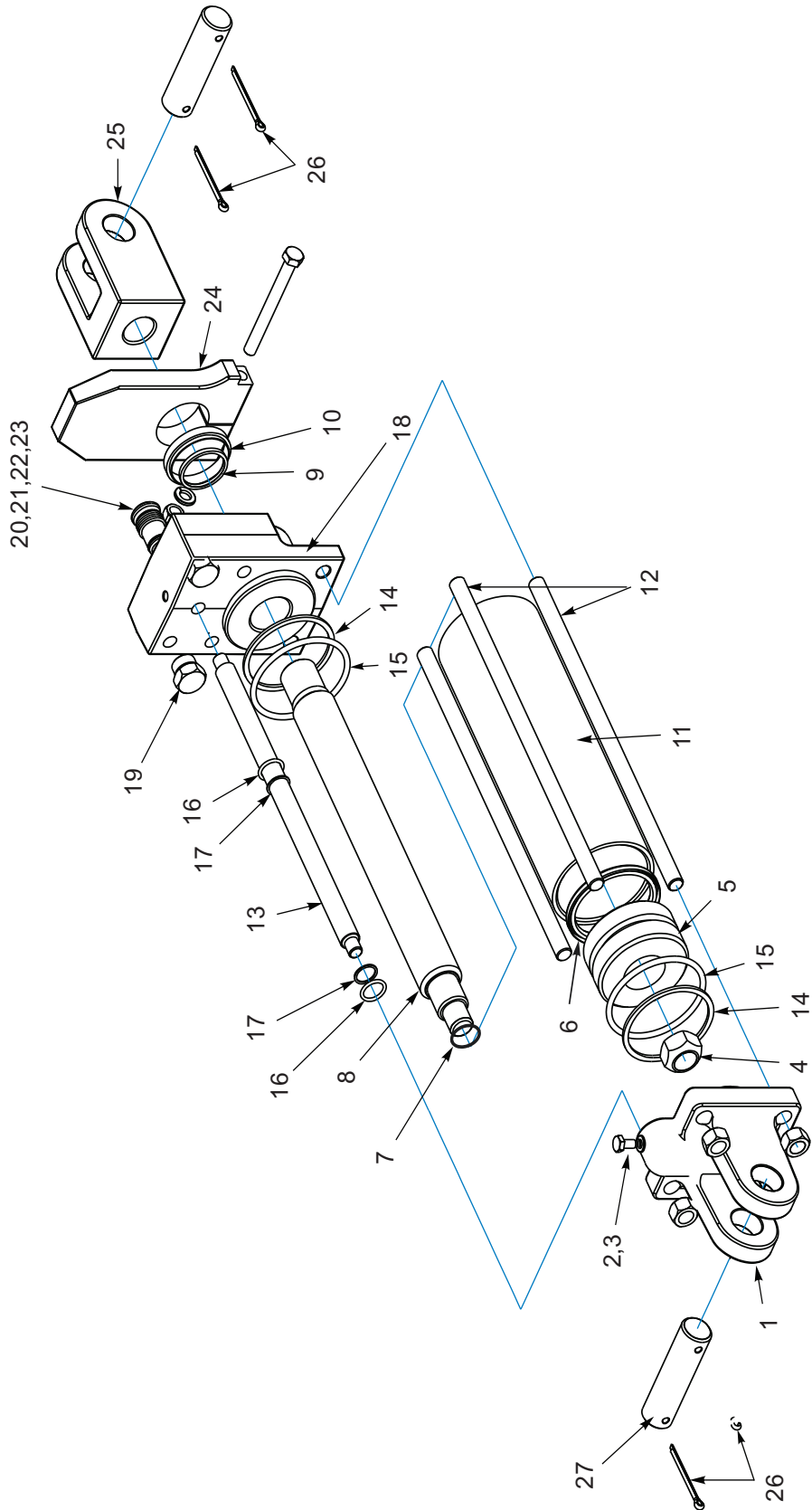

3J603

Figure 1-41: Hydraulic Cylinder, 3 x 8 - Prince

## Hydraulic Cylinder, 3 x 8 - Prince

ITEM	PART NUMBER	DESCRIPTION	QTY
	3J603	HYDRAULIC CYLINDER (CHECK CYLINDER, P = PRINCE)	1
1	-----	BUTT (BASE)	1
2	-----	NYLTITE SEAL	1
3	3J730	CAPSCREW	1
4	6D918	LOCK NUT (3/4-16)	1
5	-----	PISTON	1
6	-----	URETHANE SEAL	1
7	-----	O-RING	1
8	-----	PISTON ROD	1
9	-----	U-CUP	1
10	-----	WIPER	1
11	3J719	TUBE, CYL	1
12	3J721	TIE ROD	4
13	3J720	MANIFOLD TUBE	1
14	-----	BACK-UP WASHER	2
15	-----	O-RING	2
16	-----	O-RING	2
17	-----	BACK-UP WASHER	2
18	7J050	GLAND (WITH PORTS REQUIRING O-RINGS)	1
18	3J726	GLAND (WITH PIPE THREADS)	1
19	7J025	O-RING PLUG	1
20	9J638	VALVE ASSEMBLY	1
21	-----	O-RING	1
22	-----	O-RING	1
23	-----	BACK-UP WASHER	1
24	9J804	STRIKER PLATE ASM-5K695 - DEA	1
25	-----	CLEVIS ASSEMBLY	1
26	110-4224	PIN,COTTER 3/16 X 2 IN LG	4
27	5J650	CLEVIS PIN	2

Decals

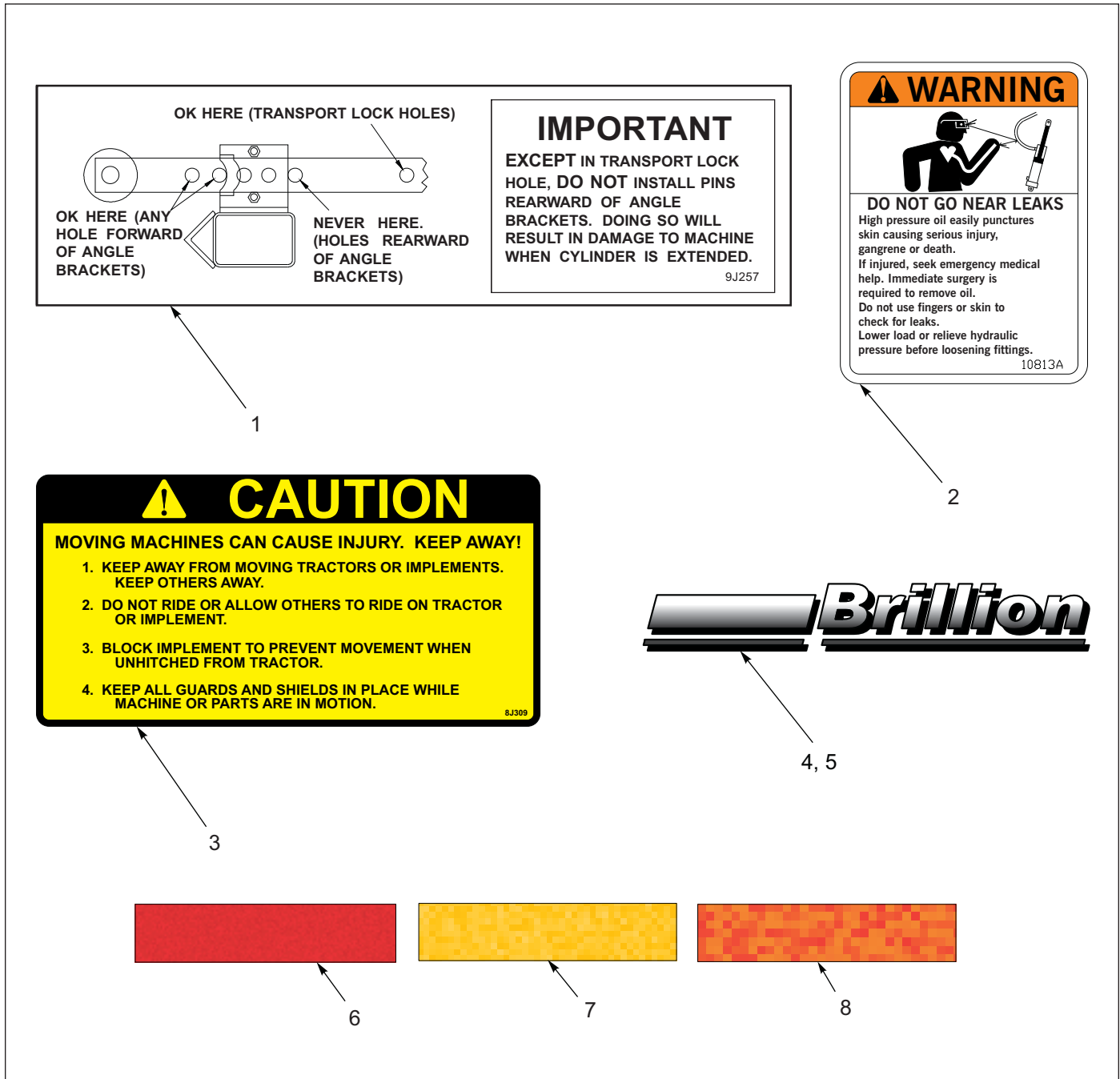

Figure 1-42: Decals

Decals

ITEM	PART NUMBER	DESCRIPTION	QTY
1	9J257	"IMPORTANT" DECAL (BEFORE 07/2016)	1
2	3K706	DECAL-WARNING HYDRAULIC LEAKS	1
3	8J309	DECAL - 'CAUTION'	1
4	4K036	DECAL-BRILLION (2 3/4 X 20)	4
5	4K039	DECAL-BRILLION (3 1/2 X 40)	2
6	528933	REFLECTOR - RED	2
7	528934	REFLECTOR - YELLOW	2

## Glossary

For clarity this glossary of industry standard abbreviations and their definitions are provided. For additional information, see instruction on the inside front cover or the last page of this manual.

**A**

**ASM** ..... Assembly

**B**

**BATT** ..... Battery  
**BHSC** ..... Button Head Socket Cap  
**BLK** ..... Black

**C**

**CB** ..... Carriage Bolt  
**CONN** ..... Connector  
**CRG** ..... Carriage  
**CTSK** ..... Countersunk  
**CTWT** ..... Counterweight  
**CVR** ..... Cover  
**CYD** ..... Cylinder

**D**

**DBL** ..... Double  
**DIA** ..... Diameter

**E**

**ENCLSD** ..... Enclosed

**F**

**FHCS** ..... Flanged Head Cap Screw  
**FHHCS** ..... Flanged Hex Head Cap Screw  
**FL OR FLG** ..... Flange  
**FLT** ..... Flat

**G**

**GA** ..... Gauge

**H**

**HHCS** ..... Hex Head Cap Screw  
**HCS** ..... High Carbon Steel  
**HD** ..... Head  
**HLCL** ..... Helical  
**HCSKT** ..... Hex Socket  
**HSFC** ..... Hex Socket Flat Countersunk  
**HYD** ..... Hydraulic

**I**

**ID** ..... Inside Diameter

**L**

**LH** ..... Lefthand  
**LKG OR LOCK** ..... Locking  
**LWR** ..... Lower

**M**

**MANF** ..... Manifold  
**MNT** ..... Mount

**N**

**NRW** ..... Narrow  
 ----- ..... Not Serviced Separately

**O**

**OD** ..... Outside Diameter  
**OHG** ..... Overhead Guard  
**ORFS OR ORS** ..... O-Ring Seal  
**ORP OR ORB** ..... O-Ring Boss

**P**

**P-STEER** ..... Power Steering  
**PTFE** ..... Polytetrafluoroethylene (Teflon)

---

**R**

RH ..... Righthand  
RND ..... Round

---

**S**

SER ..... Series  
SHCS ..... Socket Head Cap Screw  
SHLD ..... Shield  
SKT ..... Socket  
SLFLKG ..... Selflocking  
SOC ..... Socket  
SPDT ..... Single Pole Double Throw  
SPR ..... Spring  
SQ ..... Square  
SRTD ..... Serrated  
SSCR ..... Setscrew  
SST ..... Stainless Steel  
STD ..... Standard

---

**U**

UPR ..... Upper

---

**W**

WHL ..... Wheel  
WLD OR WLDMT ..... Weldment



**Numerics**

101988 .....	1-19, 1-23	1-654-010047-09 .....	1-43
104032 .....	1-51, 1-52	1-654-010047-12 .....	1-25
105-0093 .....	1-5, 1-7	1-654-010049-11 .....	1-51, 1-52
105-0228 .....	1-43	1-654-010051-06 .....	1-5
105874 .....	1-43	1-654-010051-10 .....	1-5
108417 .....	1-44	1-654-010051-13 .....	1-12
110-4224 ..	1-49, 1-50, 1-51, 1-52, 1-53, 1-55, 1-57	1-654-010051-15 .....	1-45
1-116-010019 .....	1-5, 1-7	1-654-010055-03 .....	1-47
113064 .....	1-11	1-654-010055-04 .....	1-45
1-298-010001-1 .....	1-11, 1-13	1-654-010055-15 .....	1-5, 1-7
141434 .....	1-9	1-654-010059-05 .....	1-5, 1-7
143871 .....	1-46	1-654-010059-21 .....	1-17, 1-19, 1-48
147072 .....	1-7, 1-9, 1-21, 1-23	1-654-010070-03 .....	1-27
1-512-010005-01 .....	1-43, 1-46	1-654-010070-11 .....	1-19, 1-23
1-512-010005-05 .....	1-12, 1-43	1-654-010080-2 .....	1-32
1-512-010005-09 .....	1-5, 1-7, 1-19, 1-23	168365 .....	1-25, 1-31
1-512-010005-13 .....	1-5, 1-7	168366 .....	1-25, 1-31
1-512-010005-19 .....	1-9	168367 .....	1-25, 1-31
1-512-010007-05 .....	1-25, 1-39	168371 .....	1-25, 1-29
1-512-010007-07 .....	1-45	168372 .....	1-25, 1-29
1-512-010007-09 .....	1-17, 1-19, 1-21, 1-23, 1-26, 1-27, 1-32, 1-44, 1-45, 1-47	169561 .....	1-9
1-512-010007-11 .....	1-11, 1-17, 1-19, 1-21, 1-23, 1-25, 1-46, 1-48	174435 .....	1-43
1-512-010007-12 .....	1-25, 1-48	174436 .....	1-43
151508 .....	1-9	174437 .....	1-43
1-516-010001-20 .....	1-13	175151 .....	1-43
1-557-010327 .....	1-7	175152 .....	1-43
1-557-010362-51 .....	1-13, 1-17, 1-19, 1-21, 1-23	178506 .....	1-43
164700 .....	1-43	178529 .....	1-43
1-647-010004221 .....	1-5, 1-7, 1-11	1-861-010032-06 .....	1-43
1-654-010047-06 .....	1-46	1-861-010032-11 .....	1-45
1-654-010047-07 .....	1-44	1-861-010032-15 .....	1-45
1-654-010047-08 .....	1-43	1-861-010032-18 .....	1-5, 1-7
		1-861-010032-20 .....	1-17, 1-19, 1-21, 1-23
		1-861-010032-24 .....	1-5, 1-7, 1-9, 1-11, 1-13, 1-48
		1-861-010034-09 .....	1-25, 1-39

1-861-010034-11	1-45	2J094	1-17, 1-19, 1-21, 1-23
1-861-010034-13	1-17, 1-19, 1-21, 1-23, 1-26, 1-27, 1-32, 1-44, 1-45, 1-47	2J155	1-19, 1-23
1-861-010034-15	1-3, 1-11, 1-17, 1-19, 1-21, 1-23, 1-25, 1-46, 1-48	2J241	1-19, 1-23
1-861-010034-17	1-25, 1-48	2J858	1-9
196120	1-5	2K085	1-12
199588	1-43	2K672	1-17, 1-19, 1-21, 1-23
1C023	1-11	2P071	1-5
1C205	1-48	2P111	1-53
1D594	1-5, 1-7	2P151	1-3
1J131	1-39	2P252	1-5
1J398	1-11	2P253	1-43
1J834	1-19, 1-23	2P740	1-50
1J887	1-19, 1-23	3J131	1-26, 1-27
1J961	1-49	3J450	1-25, 1-48
1K040	1-3	3J496	1-9
1K041	1-3	3J512	1-5, 1-7
1K089	1-3	3J551	1-47
1K181	1-9	3J552	1-47
1K188	1-5, 1-7, 1-9	3J556	1-47
1K892	1-12	3J557	1-47
1K951	1-3	3J561	1-44, 1-47
1K952	1-3	3J603	1-17, 1-19, 1-41, 1-55, 1-57
1K953	1-11, 1-12	3J615	1-39
1K958	1-17, 1-19, 1-21, 1-23	3J719	1-57
1K959	1-45	3J720	1-57
1K972	1-47	3J721	1-57
1K973	1-47	3J726	1-57
1K974	1-45	3J730	1-57
1P443	1-50, 1-53	3J880	1-5, 1-7
1P744	1-50, 1-53	3K045	1-26, 1-27
201436	1-5, 1-11	3K073	1-3, 1-19, 1-23
201439	1-5	3K074	1-3, 1-17, 1-21
201440	1-5	3K678	1-48
205353	1-43	3K683	1-48
2C628	1-17, 1-21	3K684	1-48
2C643	1-11	3K690	1-48
		3K693	1-48
		3K694	1-48

---

3K706 .....	1-9, 1-58	5J375 .....	1-28, 1-29, 1-30, 1-31, 1-32
3P079 .....	1-50, 1-53	5J571 .....	1-5, 1-11
415 .....	1-14	5J609 .....	1-19, 1-23
4C446 .....	1-9	5J616 .....	1-17, 1-19, 1-21, 1-23
4C856 .....	1-48	5J650 .....	1-49, 1-50, 1-51, 1-52, 1-53, 1-57
4D100 .....	1-9	5J768 .....	1-7, 1-21, 1-23
4D386 .....	1-17, 1-21	5K597 .....	1-40
4D982 .....	1-39	5K684 .....	1-55
4J549 .....	1-7	5K685 .....	1-55
4J918 .....	1-43	5K686 .....	1-55
4K036 .....	1-3, 1-58	5K687 .....	1-55
4K039 .....	1-3, 1-58	5K688 .....	1-55
4K602 .....	1-40, 1-41	5K689 .....	1-55
4K603 .....	1-40	5K690 .....	1-55
4K772 .....	1-44	5K691 .....	1-55
4K773 .....	1-44	5K692 .....	1-55
4K774 .....	1-44	5K693 .....	1-55
4K777 .....	1-39, 1-51	5K694 .....	1-55
4K780 .....	1-44	5K695 .....	1-55
4K800 .....	1-44	5K696 .....	1-55
4K861 .....	1-40	5K697 .....	1-55
4K881 .....	1-40	5K698 .....	1-55
4K912 .....	1-40, 1-41	5K699 .....	1-55
4K919 .....	1-41	5K793 .....	1-51
528933 .....	1-3, 1-43, 1-58	6C400 .....	1-5, 1-7
528934 .....	1-3, 1-9, 1-43, 1-58	6D148 .....	1-39
528938 .....	1-43	6D309 .....	1-11
5C078 .....	1-17, 1-19, 1-21, 1-23	6D312 .....	1-14
5C100 .....	1-11	6D333 .....	1-5, 1-7
5C479 .....	1-13	6D336 .....	1-13
5C480 .....	1-13	6D337 .....	1-13
5C913 .....	1-13	6D338 .....	1-13
5C914 .....	1-13	6D918 .....	1-57
5D012 .....	1-48	6J045 .....	1-5, 1-7
5D110 .....	1-21, 1-23	6J459 .....	1-5, 1-7
5D921 .....	1-17, 1-19, 1-21, 1-23	6J460 .....	1-5, 1-7
5J080 .....	1-19, 1-23	6J580 .....	1-7
5J195 .....	1-51, 1-52	6J765 .....	1-13

---

6J766 .....	1-12, 1-13	8J650 .....	1-25, 1-39, 1-40
6K103 .....	1-37	8J790 .....	1-14
6K104 .....	1-36	8J903 .....	1-5, 1-7
6K105 .....	1-36, 1-37	8J918 .....	1-49
6K132 .....	1-36, 1-37	9C031 .....	1-32
6K169 .....	1-29, 1-31, 1-35	9D524 .....	1-39, 1-49, 1-50
6K170 .....	1-35	9D653 .....	1-11
6K190 .....	1-35, 1-36	9D662 .....	1-17, 1-21
6K191 .....	1-35, 1-37	9D673 .....	1-32
6K302 .....	1-40	9D674 .....	1-44
6K458 .....	1-5, 1-7	9D851 .....	1-39, 1-44
6K843 .....	1-5, 1-7, 1-11, 1-39, 1-40, 1-52, 1-53	9D923 .....	1-13
6K919 .....	1-14	9J090 .....	1-3, 1-17, 1-21
6K926 .....	1-11	9J091 .....	1-3, 1-19, 1-23
7D014 .....	1-19, 1-23	9J096 .....	1-17, 1-21
7D728 .....	1-19, 1-23	9J103 .....	1-3
7J025 .....	1-57	9J104 .....	1-3
7J026 .....	1-39	9J107 .....	1-21
7J050 .....	1-57	9J108 .....	1-19, 1-23
7J067 .....	1-50, 1-55	9J109 .....	1-19, 1-23
7J237 .....	1-17, 1-19	9J110 .....	1-19, 1-23
7J990 .....	1-3, 1-25, 1-46	9J111 .....	1-17, 1-19, 1-21, 1-23
7K260 .....	1-52	9J112 .....	1-19, 1-23
8D857 .....	1-9	9J114 .....	1-23
8J001 .....	1-28, 1-29	9J120 .....	1-17, 1-21
8J014 .....	1-45	9J143 .....	1-23
8J015 .....	1-45	9J144 .....	1-23
8J051 .....	1-46	9J145 .....	1-21
8J083 .....	1-7, 1-21, 1-23	9J146 .....	1-21
8J085 .....	1-5, 1-7	9J187 .....	1-3, 1-25
8J104 .....	1-5, 1-7	9J214 .....	1-17, 1-19
8J113 .....	1-5, 1-7	9J216 .....	1-17, 1-19
8J118 .....	1-5, 1-7	9J218 .....	1-17
8J127 .....	1-46	9J220 .....	1-19
8J163 .....	1-5, 1-7	9J257 .....	1-7, 1-58
8J172 .....	1-17, 1-21	9J277 .....	1-30, 1-31
8J212 .....	1-5, 1-7	9J278 .....	1-5, 1-7
8J309 .....	1-3, 1-58	9J500 .....	1-28, 1-29

9J502 .....	1-34
9J503 .....	1-34
9J515 .....	1-30, 1-34
9J516 .....	1-28
9J522 .....	1-25, 1-28
9J523 .....	1-25
9J560 .....	1-25, 1-27
9J561 .....	1-27
9J570 .....	1-26
9J581 .....	1-45
9J582 .....	1-45
9J584 .....	1-45
9J588 .....	1-45
9J638 .....	1-57
9J804 .....	1-57
9J811 .....	1-30, 1-31
9J818 .....	1-31
9J819 .....	1-30, 1-31
9J830 .....	1-25, 1-30
9J832 .....	1-25, 1-30
9J833 .....	1-25, 1-30
9J882 .....	1-26
9J883 .....	1-25, 1-26



## Document Control Revision Log:

Date	Form #	Improvement(s): Description and Comments
11/08/2007	997rev1105	Initial Release
09/2012	997rev0912	Improved Pictures, Translated to Landoll Format, Incorporated Engineering Changes
01/2017	997rev0117	Added LED Warning Lights *23/03 Land Leveler Kit - Enhanced Drawing, No Part Changes



---

# Intertek

Equipment from Landoll Company, LLC is built to exacting standards ensured by ISO 9001 registration at all Landoll manufacturing facilities.

## **ML RIGID PULVI-MULCHER**

**Models: 2253**

**ML, MLS, MCL, MCLS, MLC,  
MLCS, MCC, and MCCS**

## **Parts Manual**

**Re-Order Part Number 1K975**

**LANDOLL COMPANY, LLC**

1900 North Street

Marysville, Kansas 66508

(785) 562-5381

**800-428-5655 ~ WWW.LANDOLL.COM**



Copyright 2023. Landoll Company, LLC

“All rights reserved, including the right to reproduce this material or portions thereof in any form.”