

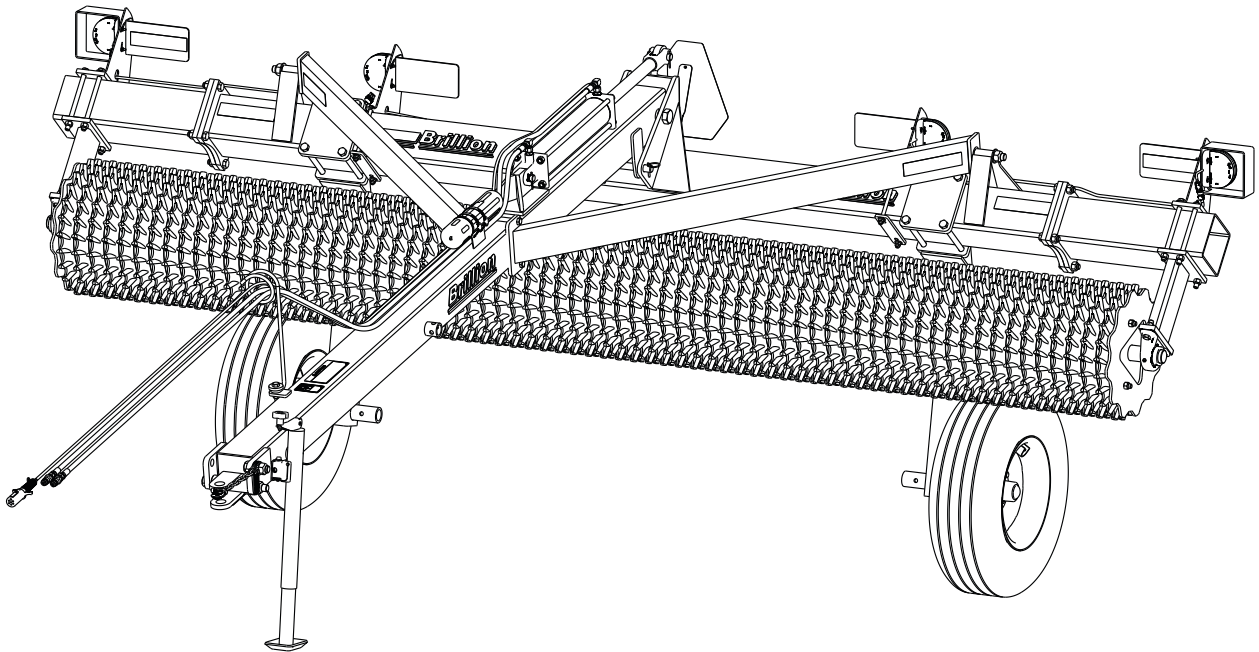

Floating Ring Pulverizer PFT 10' through 18' Models Operator's Manual



LANDOLL COMPANY, LLC

1900 North Street
Marysville, Kansas 66508
(785) 562-5381

800-428-5655 ~ WWW.LANDOLL.COM

Table of Contents

1 Introduction and Safety Information

Introduction	1-1
Description of Unit	1-1
Owner Assistance	1-1
Warranty Registration	1-1
Safety	1-2
Transporting Safety	1-3
Safety Instructions for Towing Vehicles	1-3
Attaching, Detaching and Storage	1-3
Maintenance Safety	1-3
Protective Equipment	1-3
High Pressure Fluid Safety	1-3
Prepare for Emergencies	1-3
Tire Safety	1-4
Safety Chain	1-4
Decals	1-5

2 Assembly

Roller and Frame	2-1
Drawbar Installation	2-2
Wheel Arm Assembly	2-4
Hydraulic Circuit Installation	2-6
LED Lights Installation	2-8
Single and Dual Wheel Kits - Optional	2-10

3 Operation

Parking	3-4
Attaching to Equipment	3-4
Transport Lock	3-4
Field Operations	3-5
Roller Orientation	3-5
Reflectors and SMV Sign	3-6
LED 7-Pin Connector	3-6

4 Maintenance

General Torque Specifications	4-1
Hydraulic Fitting Torque Specifications	4-2
Fasteners	4-3
Lubrication	4-3
Tires	4-4
Hydraulic System	4-4
Replacing or Adding Roller Wheels	4-4

5 General Reference and Specifications

Introduction and Safety Information

Introduction

The implement described in this manual has been designed with care and built by skilled workers using quality materials and processes. Proper assembly and maintenance will provide you with satisfactory use for seasons to come.



DANGER

Read this entire manual before attempting to assemble, adjust or operate this implement. Failure to comply with this warning can result in personal injury or death, damage to the implement or its components and inferior operation.

Description of Unit

The Brillion Floating Ring Series was designed as a companion tool for use behind a primary tillage machine to firm and level the soil into a plantable medium. The ability of the Pulverizer rings to move on the drum provides a self-cleaning feature that lends itself to efficient operation even in moist conditions. The floating rings follow the rugged soil contours found after using a primary tillage machine.

Using this Manual

This manual will familiarize you with safety, assembly, operation, adjustment, and maintenance. Read this manual and follow the recommendations to help ensure safe and efficient operation.

- The information in this manual is current at time of printing. Some parts may have changed to assure top performance.
- Location reference: Right and Left designations in this manual are determined by facing the direction the implement will travel during field operation, unless otherwise stated.

Owner Assistance

If customer service or repairs are needed, contact your Brillion dealer. They have trained personnel, parts and service equipment specially designed for Brillion products. Your implement's parts should only be replaced with Brillion parts. If items covered in this manual are not understood, contact your local Brillion Dealer.

Warranty Registration

Brillion Farm Equipment, by Landoll, shall have no warranty obligation unless each product is registered within 10 days of retail purchase, using the Landoll Company, LLC Ag Products on-line registration process. Please refer to the Ag Products Policy and Procedures Manual, accessible at www.landoll.com for step by step instructions regarding product registration.

Enter your product information below for quick reference.

MODEL NUMBER _____

SERIAL NUMBER _____

DATE OF PURCHASE _____

Refer to the ID plate as shown. See Figure 1-1.



Figure 1-1: ID Plate

Safety

NOTE

Investigation has shown that nearly 1/3 of all farm accidents are caused by careless use of machinery. Insist that all people working with you or for you abide by all safety instructions.

You will find various types of safety information on the following pages and on the implement decals (signs) attached to the implement. This section explains their meaning.

NOTICE

Special notice - read and thoroughly understand.



CAUTION

Proceed with caution. Failure to heed caution may cause injury to person or damage product.



WARNING

Proceed with caution. Failure to heed warning will cause injury to person or damage product.



DANGER

Proceed with extreme caution. Failure to heed notice will cause injury or death to person and/or damage product.

NOTE

You should read and understand the information contained in this manual and on the implement decals before you attempt to operate or maintain this equipment.

Examine safety decals and be sure you have the correct safety decals for the implement. **See Figure 1-3.**

Order replacement decals through your Brillion dealer.

Keep these signs clean so they can be observed readily. It is important to keep these decals cleaned more frequently than the implement. Wash with soap and water or a cleaning solution as required.

Replace decals that become damaged or lost. Also, be sure that any new implement components installed during repair include decals which are assigned to them by the manufacturer.

When applying decals to the implement, be sure to clean the surface to remove any dirt or residue. Where possible, sign placement should protect the sign from abrasion, damage, or obstruction from mud, dirt, oil etc.



DANGER

- Do not allow anyone to ride on the tractor or implement. Riders could be struck by foreign objects or thrown from the implement.
- Never allow children to operate equipment.
- Keep bystanders away from implement during operation.

Transporting Safety

IMPORTANT

It is the responsibility of the owner/operator to comply with all state and local laws.

When transporting the implement on a road or highway, use adequate warning symbols, reflectors, lights and slow moving vehicle sign as required. Slow moving tractors and towed implements can create a hazard when driven on public roads. They are difficult to see, especially at night.

Do not tow an implement that, when fully loaded, weighs more than 1.5 times the weight of the towing vehicle.

Carry reflectors or flags to mark the tractor and implement in case of breakdown on the road.

Do not transport at speeds over 20 MPH under good conditions. Never travel at a speed which does not allow adequate control of steering and stopping. Reduce speed if towed load is not equipped with brakes

Avoid sudden stops or turns because the weight of the implement may cause the operator to lose control of the tractor. Use a tractor heavier than the implement.

Use caution when towing behind articulated steering tractors; fast or sharp turns may cause the implement to shift sideways.

Keep clear of overhead power lines and other obstructions when transporting. Know the transport height and width of your implement.

Safety Instructions for Towing Vehicles

The maximum travel speed is the lesser of

- The limit of the road conditions;
- The maximum specified ground speed;
 - for towing operations as indicated in this manual or SIS;
 - of the towed vehicle as indicated in its operator's manual, SIS, or information sign;

- The maximum ground speed of the towed equipment combination shall be limited to the lowest specified ground speed of any of the towed machines. This speed is the ground speed limitation.

EXAMPLE: If the tractor is capable of 40 km/h, the first implement has a SIS for 30 km/h, and the last implement's operator's manual states its specified ground speed is 25 km/h, the towed equipment combination ground speed limitation is 25 km/h.

Attaching, Detaching and Storage

- Do not stand between the tractor and implement when attaching or detaching implement unless both are blocked from moving.
- Block implement so it will not roll when unhitched from the tractor.

Maintenance Safety

- Block the implement so it will not roll when working on or under it to prevent injury.
- Do not make adjustments or lubricate the machine while it is in motion.
- Make sure all moving parts have stopped.
- Understand the procedure before doing the work. Use proper tools and equipment.

Protective Equipment

- Wear protective clothing & equipment appropriate for the job. Avoid loose fitting clothing.
- Because prolonged exposure to loud noise can cause hearing impairment or hearing loss, wear suitable hearing protection, such as earmuffs or earplugs.

High Pressure Fluid Safety

Escaping fluid under pressure can be nearly invisible and have enough force to penetrate the skin causing serious injury. Use a piece of cardboard, rather than hands, to search for suspected leaks.

Any fluid injected into the skin must be surgically removed within a few hours or gangrene may result.

Avoid the hazard by relieving pressure before disconnecting hydraulic lines.

Prepare for Emergencies

- Keep a First Aid Kit and Fire Extinguisher handy.
- Keep emergency numbers for the doctor, ambulance, hospital and fire department near the phone.

Tire Safety

Tire changing can be dangerous and should be performed by trained personnel using correct tools and equipment.

When inflating tires, use a clip-on chuck and extension hose long enough to allow you to stand to one side, not in front of or over the tire assembly. Use a safety cage if available.

When removing and installing wheels use wheel-handling equipment adequate for the weight involved.

Safety Chain

Use the safety chain to help control drawn machinery should it separate.

Use a chain with a strength rating equal to or greater than the gross weight of towed machinery, which is 21,000 pounds minimum in accordance with ASAE S338.2 specifications. If two or more implements are pulled in tandem, a larger chain may be required. Chain capacity must be greater than the TOTAL weight of all towed implements.

A second chain should be used between each implement.

Attach the chain to the specified location. Allow only enough slack in the chain to permit turning. **See Figure 1-2.**

Replace the chain if any links or end fittings are broken, stretched or damaged.

Do not use a safety chain for towing.

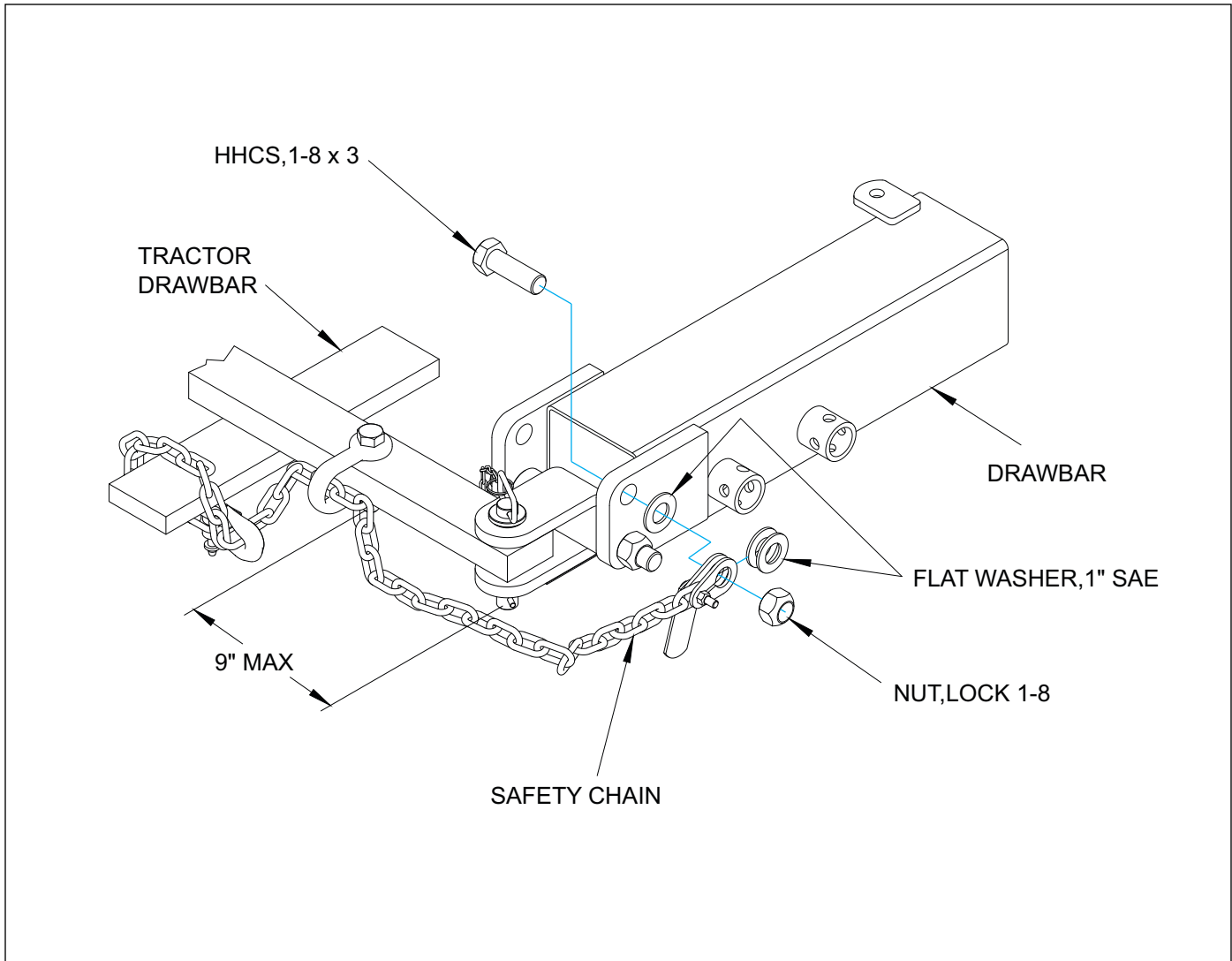
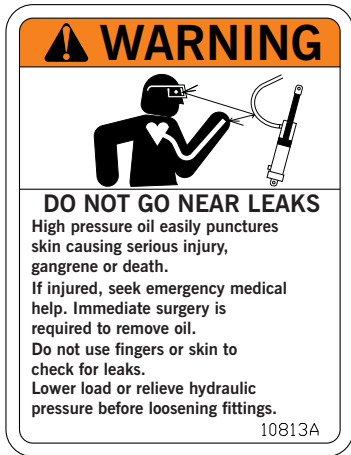

Figure 1-2: Safety Chain

Decals



3K706



4K103



4K036



528933



528934



528938

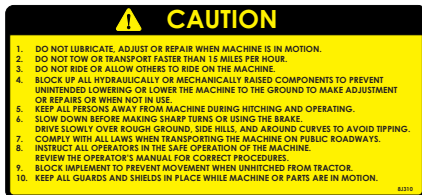

8J310

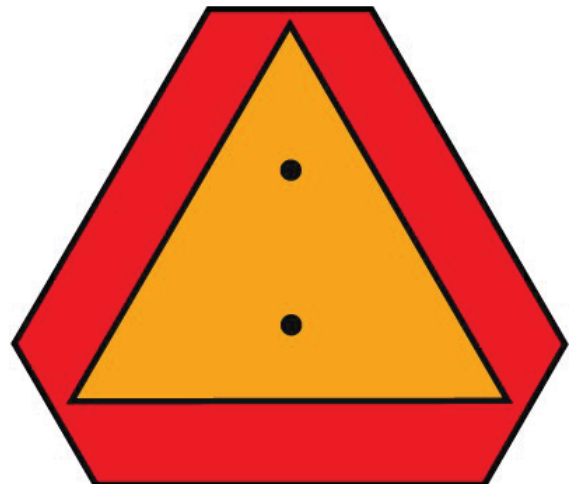

2P151

Figure 1-3: Decals

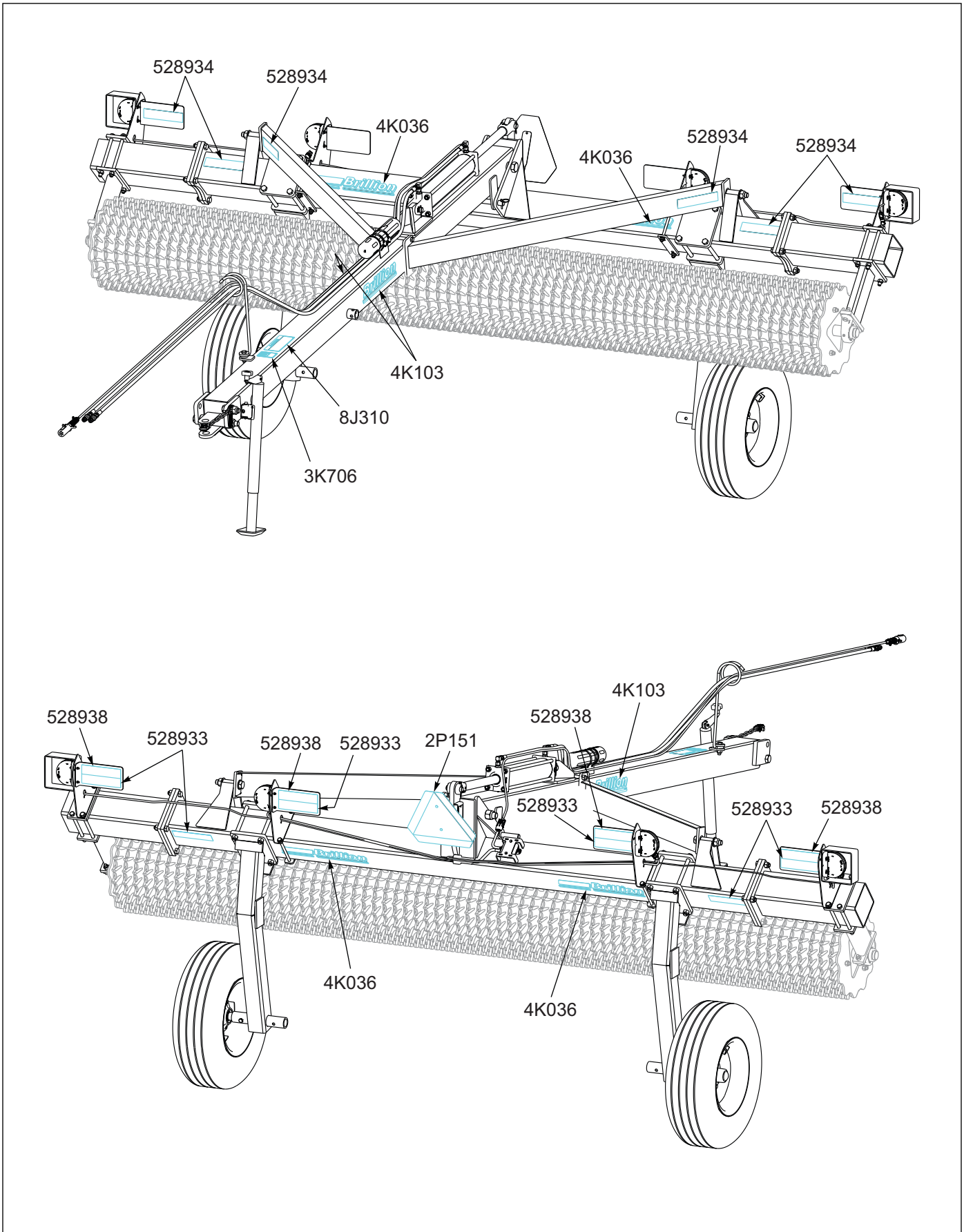

Figure 1-4: Decal Locations

This chapter covers proper assembly of your Floating Ring Pulverizer. Refer to the Floating Ring Pulverizer Parts Manual 5K088 for complete part breakdowns and proper location of any parts not shown in the following illustrations.

NOTE

The machine shown in the following illustrations may not agree with the size of your unit. Assembly of machines, however, is similar on all models. Additional parts identification and location can be obtained by reviewing the parts manual.



WARNING

Do not work on or under this machine unless securely blocked and supported by a hoist or tractor or by other sufficient means.

IMPORTANT

- If pre-assembled parts or fasteners are temporarily removed, remember where they go. It is best to keep the parts separated.

- Check that all working parts move freely, bolts are tight and cotter pins are spread.
- Refer to the Torque Table for proper bolt torque values. Note the different torque requirement for bolts with lock nuts. **See Page 4-1.**

“Left” and “Right” refer to directions seen as if standing behind the machine and facing in the direction of forward travel.

Roller and Frame

The Roller and Frame are pre-assembled at the factory. Select a smooth, level area that can be reached by a hoist or lift truck. Place blocks both behind and in front of the roller wheels. Using an overhead hoist, raise the frame so that it is about 16 inches off the ground. Use at least three blocks to secure the frame in this position.

See Figure 2-1.

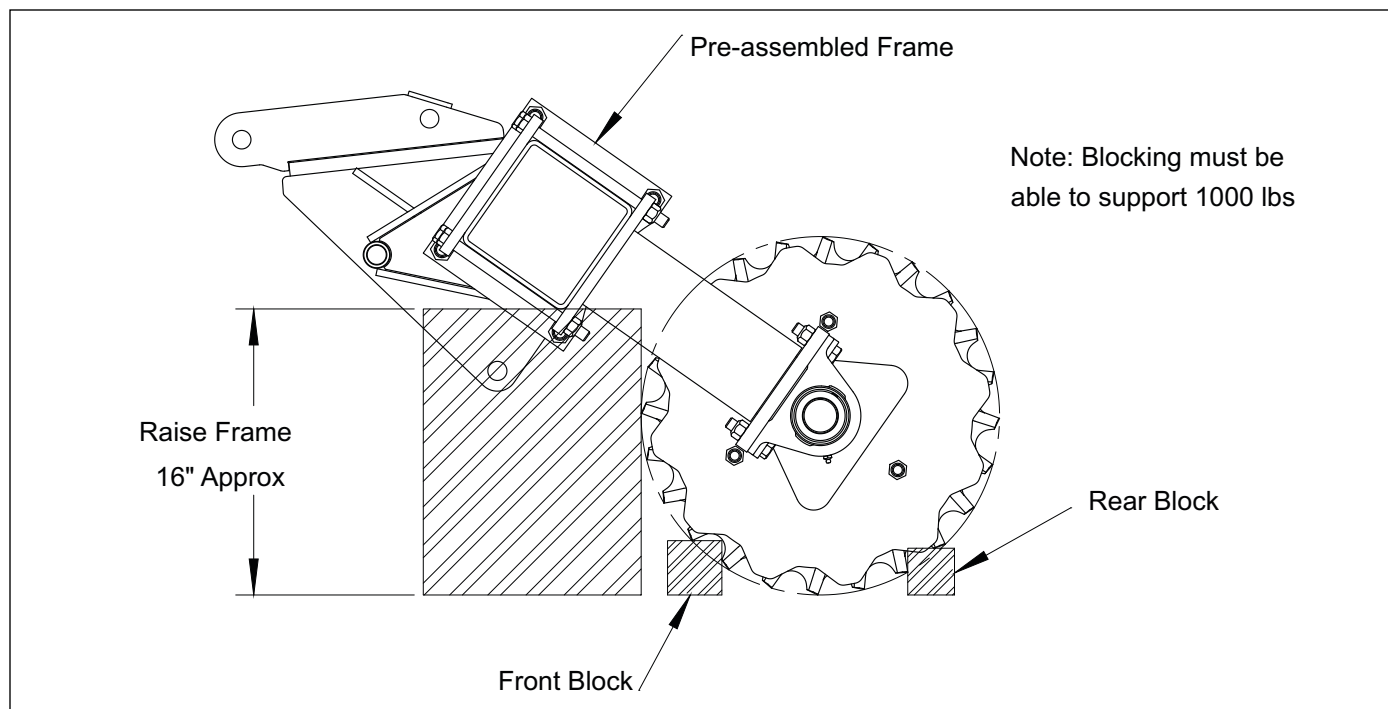

Figure 2-1: Roller and Frame Assembly

Drawbar Installation

Bring the rear of the Drawbar into position between the Frame Hitch Plates at the center of the Frame. Place two 1-1/4 x 1-7/8 x 14 ga Machinery Bushings on each side between the Drawbar and the Frame Hitch Plates. Attach the Drawbar to the Frame with 1-1/4-7 x 10-1/2 Bolt and Locknut. *The locknut should be tightened so that the frame is free to pivot on the drawbar.* See Figures 2-2 and 2-4.

Attach the Brace to the inside of the Frame Brace Lug. Slide Flat Washer onto 1-8 X 5-1/2 Bolt and insert bolt through Brace. Add another Flat Washer and slide Bolt through Frame Brace Lug. Add Flat Washers and Locknut, tighten so that the Frame is free to pivot on the Drawbar. Repeat for the opposite side. See Figures 2-3 and 2-4.

Rotate the braces so they are against the Drawbar, with one hole above and one hole below. Insert 5/8-11 x 8 Bolts through the holes and secure with Locknuts. *These locknuts should be tightened securely (110 Ft-Lbs).*

Mount the Hose Support to the Drawbar using 5/8-11 x 2 Bolt, Washer and Locknut.

Attach the Jack using the pin provided.

Attach the Manual Storage Canister using two 4-1/2 Hose Clamps.

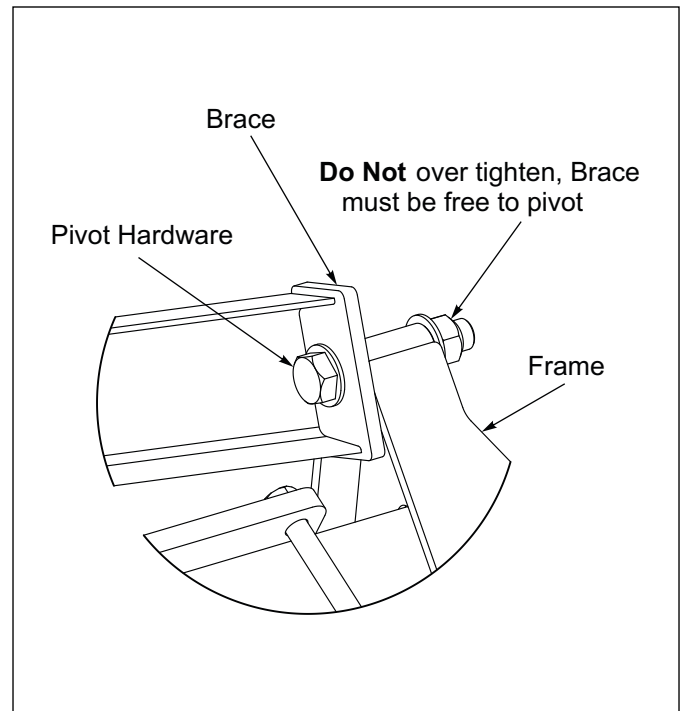

Figure 2-3: Frame Brace Lugs

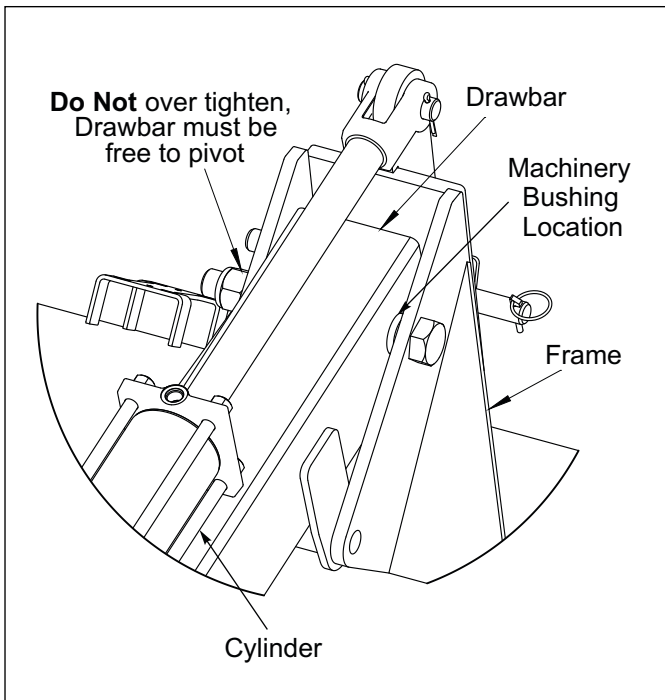

Figure 2-2: Drawbar to Hitch Plates

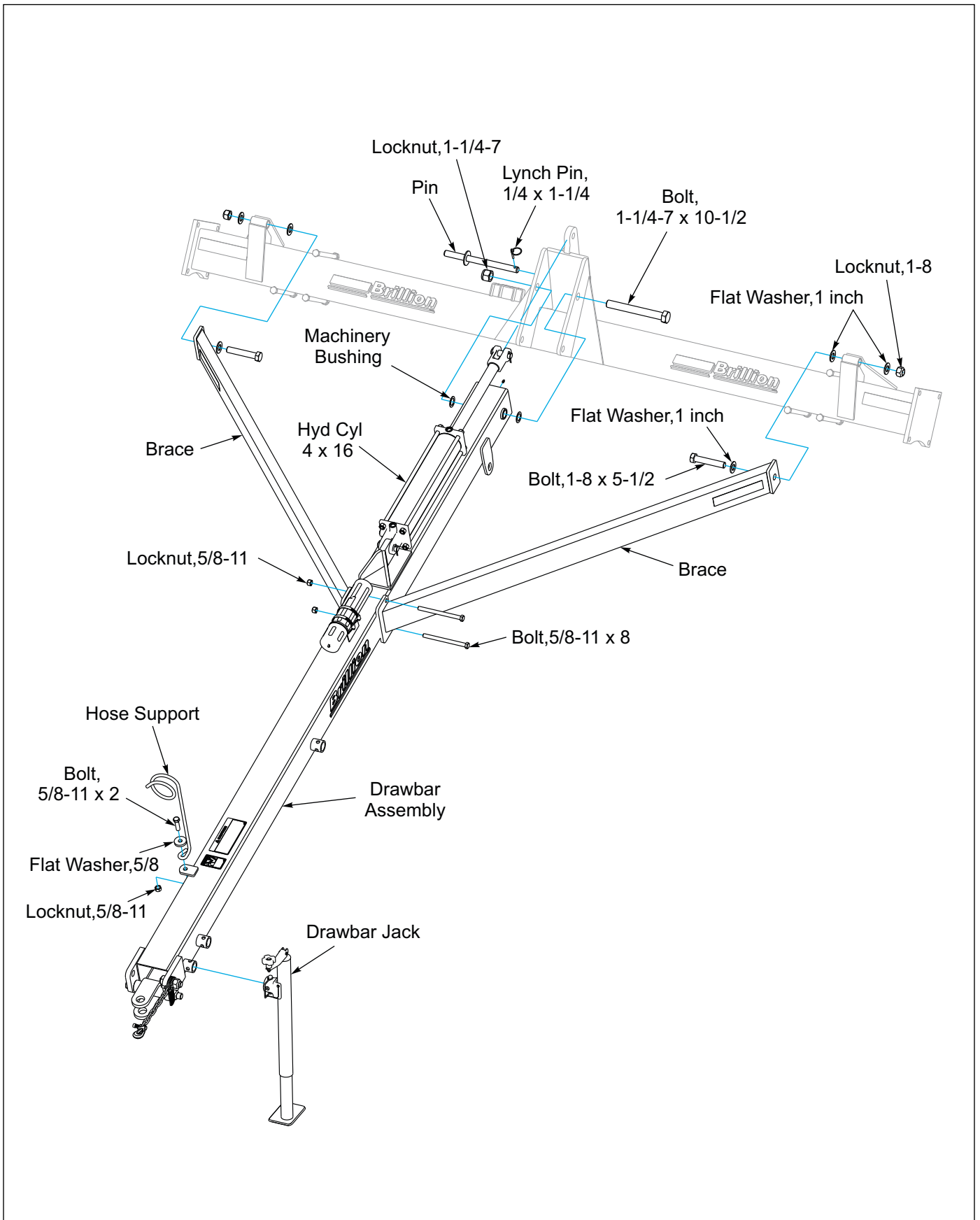

Figure 2-4: Drawbar

Wheel Arm Assembly

Attach the Wheel Arms to the Frame. The Wheel Arms should be equally spaced from the center of the machine.

See Figure 2-5. Fasten the Wheel Arms to the Frame with 4 Hole Plates and eight 3/4-10 x 9-1/2 Bolts and Locknuts. Insert the Hub and Spindle Assembly into the Wheel Arms, using the hole in the spindle which is closest to the hub. Lock spindle in place with the 1/2-13 x 3 Bolt, secure with Locknut. Attach Tire and Wheel to the Hub and Spindle with the 1/2-20 x 1 Wheel Bolts. **See Figure 2-6.**

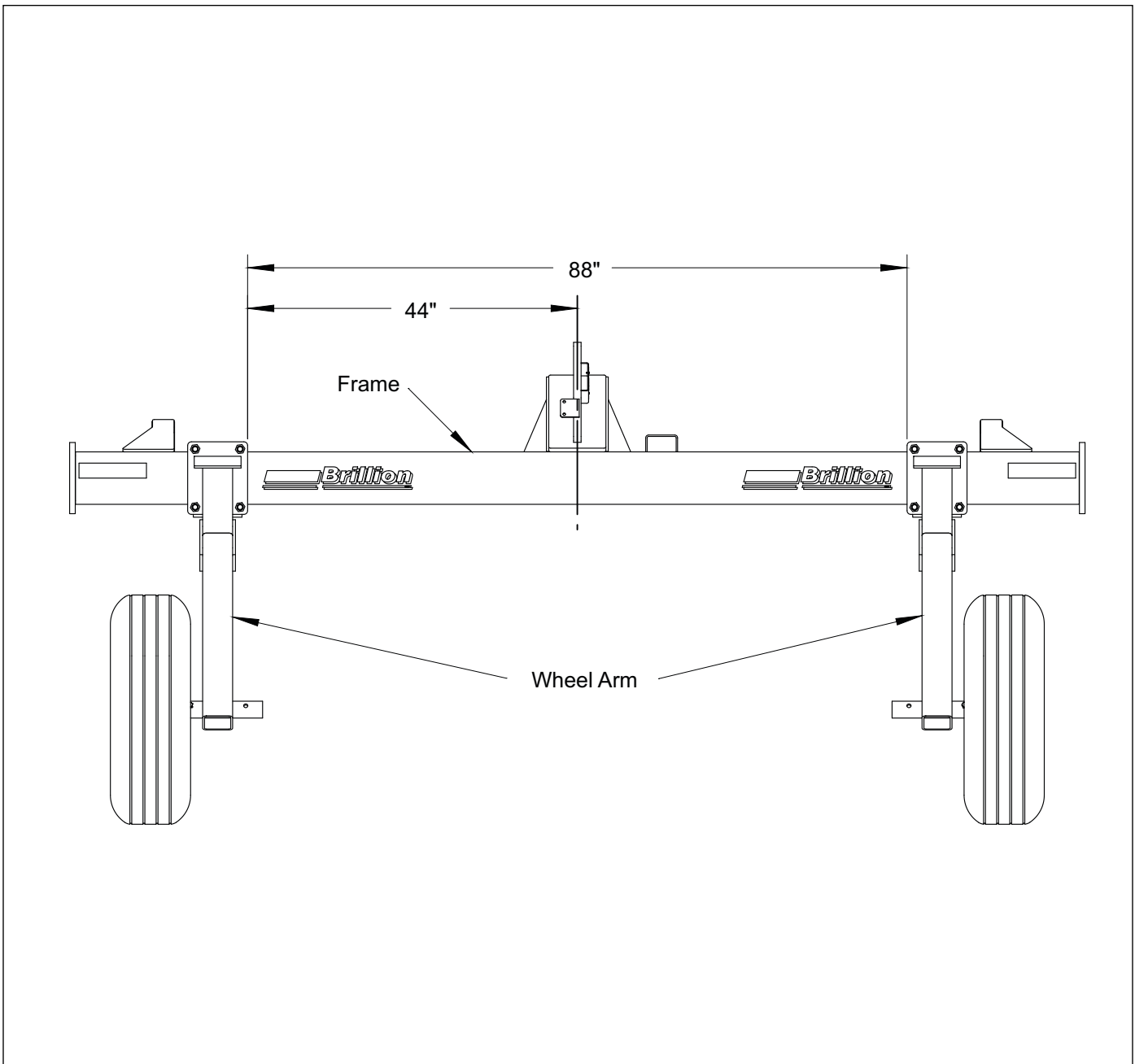

Figure 2-5: Wheel Arm Mounting Dimensions

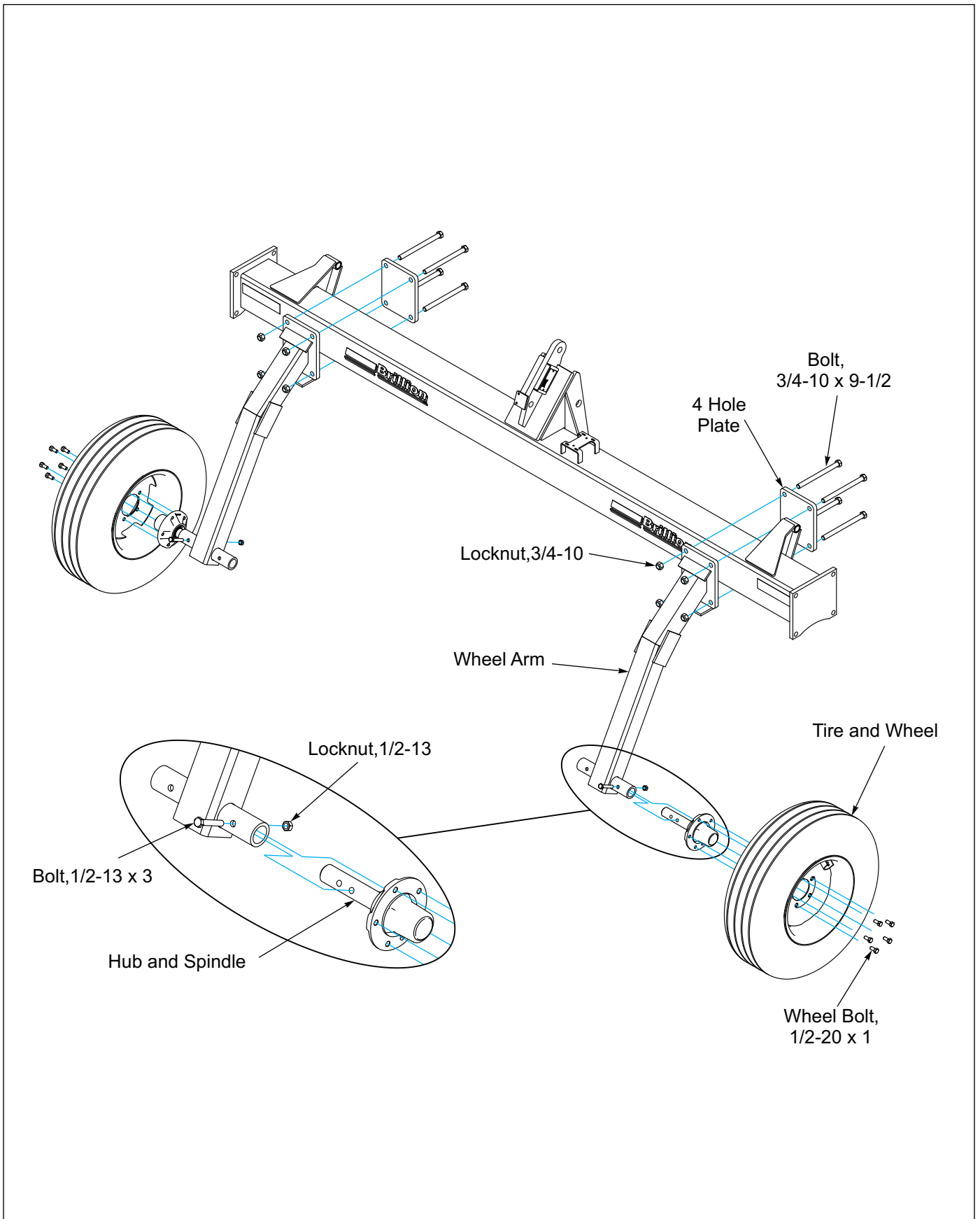

Figure 2-6: Wheel Arm Assembly

Hydraulic Circuit Installation



WARNING

Escaping fluid under pressure can be nearly invisible and have enough force to penetrate the skin causing serious injury. Use a piece of cardboard, rather than hands, to search for suspected leaks. Wear protective gloves & safety glasses or goggles when working with hydraulic systems.

Screw a Restrictor into each cylinder port and turn a 90 degree Male JIC x Female Swivel JIC Elbow Fitting onto the Restrictor. Connect 3/8 x 185 Hose Assembly to the Cylinder rod end Elbow Fitting and 3/8 x 161 Hose Assembly to the Cylinder base end. Route the two Hose Assemblies along the Drawbar and under the manual canister bracket through the Hose Support. Assemble Male ORB X Male JIC Adapter Fittings into Male Couplers and turn them into the end of the Hoses. **See Figure 2-7.**

Tightening Procedure For JIC 37° Swivel Female Nuts

1. Check flare and seat for defects.
2. Lubricate the connection.
3. Install hoses without twists.
4. Hand tighten until connection bottoms.
5. Using 2 wrenches to prevent twisting, rotate the swivel nut 2 wrench flats (1/3 turn).
6. For reassembly, follow the same procedure but tighten only 1 wrench flat (1/6 turn).

Tightening Procedure For Swivel O-Ring Fittings

1. Lubricate O-Ring and install the fitting until the metal washer which backs up the o-ring contacts the face of the boss.
2. Orient the fitting by turning counterclockwise up to 1 turn.
3. Tighten the lock nut using 50-60 foot pounds torque.

(See “Hydraulic Fitting Torque Specifications” on page 4-2.)



CAUTION

Do not raise the machine without the use of hydraulics. This would introduce air into the hydraulic cylinder. When the transport pin is removed the frame would lower rapidly possibly causing injury.

Remove Fitting Caps prior to installing Fittings.

Attach the hydraulic cylinder base end to the drawbar lug and the rod end to the frame lug. It may be necessary to extend the cylinder rod or raise the frame slightly to make this connection. Use the cylinder pins packaged with the cylinder to attach the cylinder to the machine. Be sure to bend the cotter pins so that the cylinder mounting pins cannot disengage.

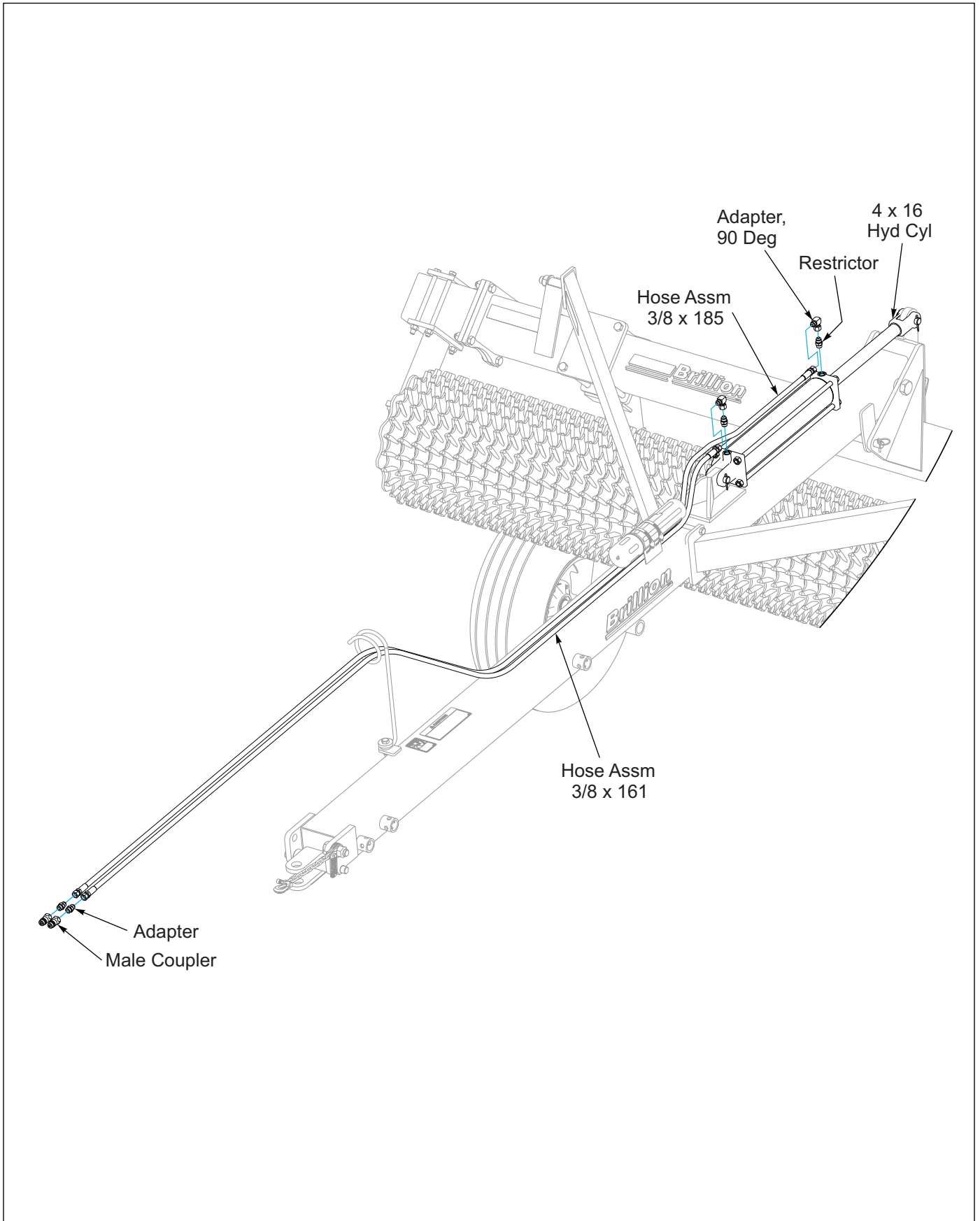

Figure 2-7: Hydraulic Circuit Installation

LED Lights Installation

NOTE

10' through 18' models similar.

See Figure 2-9.

1. Remove the two inner Bearing Support 5/8-11 x 9-1/2 Bolts and Locknuts. Set the outer Light Mount Brackets against 4 hole plate. Add Flat Washer under bolt head and re-install
2. Attach the inner Light Mount Brackets to the frame approximately 42 inches from centerline, placing the strap under the frame and secure using 1/2-13 x 8-1/2 Bolts, Flat Washers and Flange Locknuts.
3. Install the Amber LED inside the Tube Light Shield, attach to the outer Light Bracket using four 1/4-20 x 1-3/4 Bolts. Attach Decal Plate and secure with Locknuts.
4. Install the Red LED to the inside Light Mount Brackets using four 1/4-20 x 1-1/2 Bolts. Attach Decal Plate and secure with Locknuts.
5. Attach the Flasher Control Module to the Module Bracket located near the center of the frame using two 1/4-20 x 1-1/2 Bolts and Locknuts.
6. Lay out the Lamp Harness, noting that the connectors marked with Green Tape is Right Side and Yellow Tape is Left Side.
7. Plug the Lamp Harness into the Flasher Control Module, route both cord plugs with Green Tape along the top of rear frame. Route the plugs up through the Light Bracket and plug the 3 prong cord into the Red LED. Plug the 2 prong cord into the Amber LED.
8. Repeat for the Left Side (Yellow Tape).
9. Plug the 7 Pin Harness into the Flasher Control Module, then route the harness along the Drawbar with hoses and secure with Tie Straps.

NOTE

All wires must be firmly attached to machine frame members so they do not sag or become torn loose by field debris.

10. Adjust the LED lamp angles so LED's are vertical with the drawbar height adjusted to the transport height. Adjustment is provided to compensate for high drawbar heights if used as a companion tool or lower heights if towed directly behind a tractor. See Figure 2-8.
11. Tighten all hardware.
12. Bundle and secure any excess cord with tie straps.
13. Attach the SMV Sign to the center frame weldment using two 5/16-18 x 1 Bolts, Flat Washers and Locknuts.

14. Apply the reflector decals to Decal Plate Mounts. The amber reflector decals should be front facing on the outer Decal Plate Mounts. The red reflector decals and orange decals should be rear facing on both the inner and outer decal plate mounts.

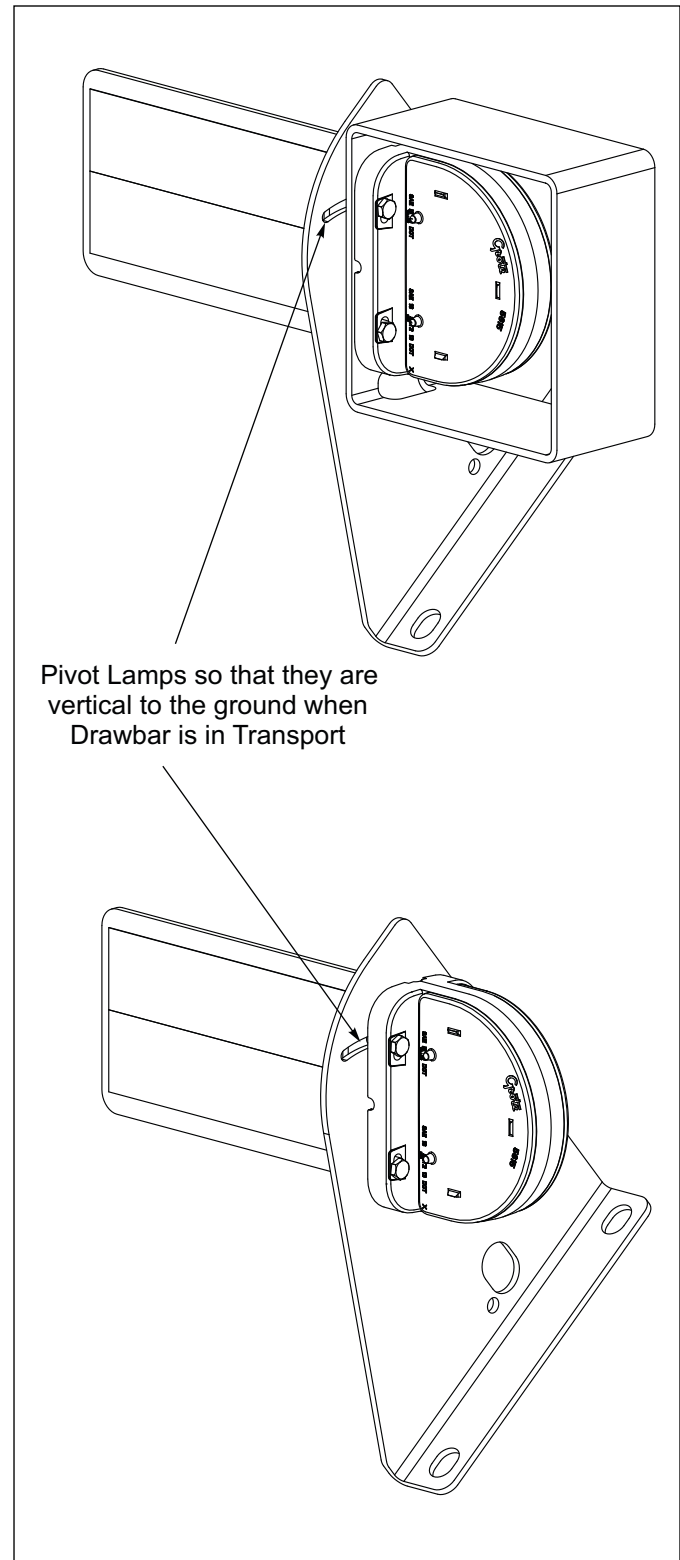

Figure 2-8: LED Lamp Adjustment

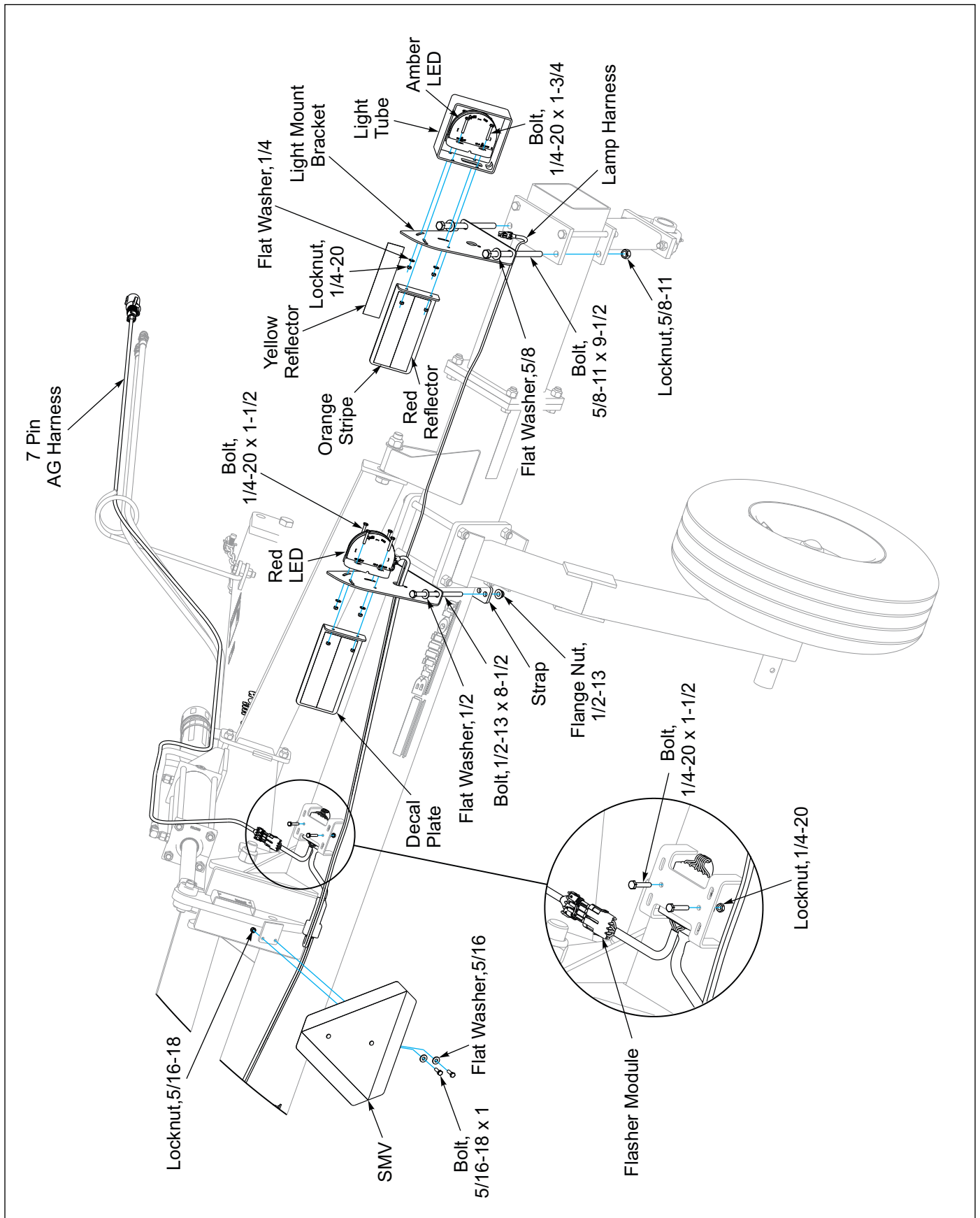

Figure 2-9: LED Light Installation

Single and Dual Wheel Kits - Optional

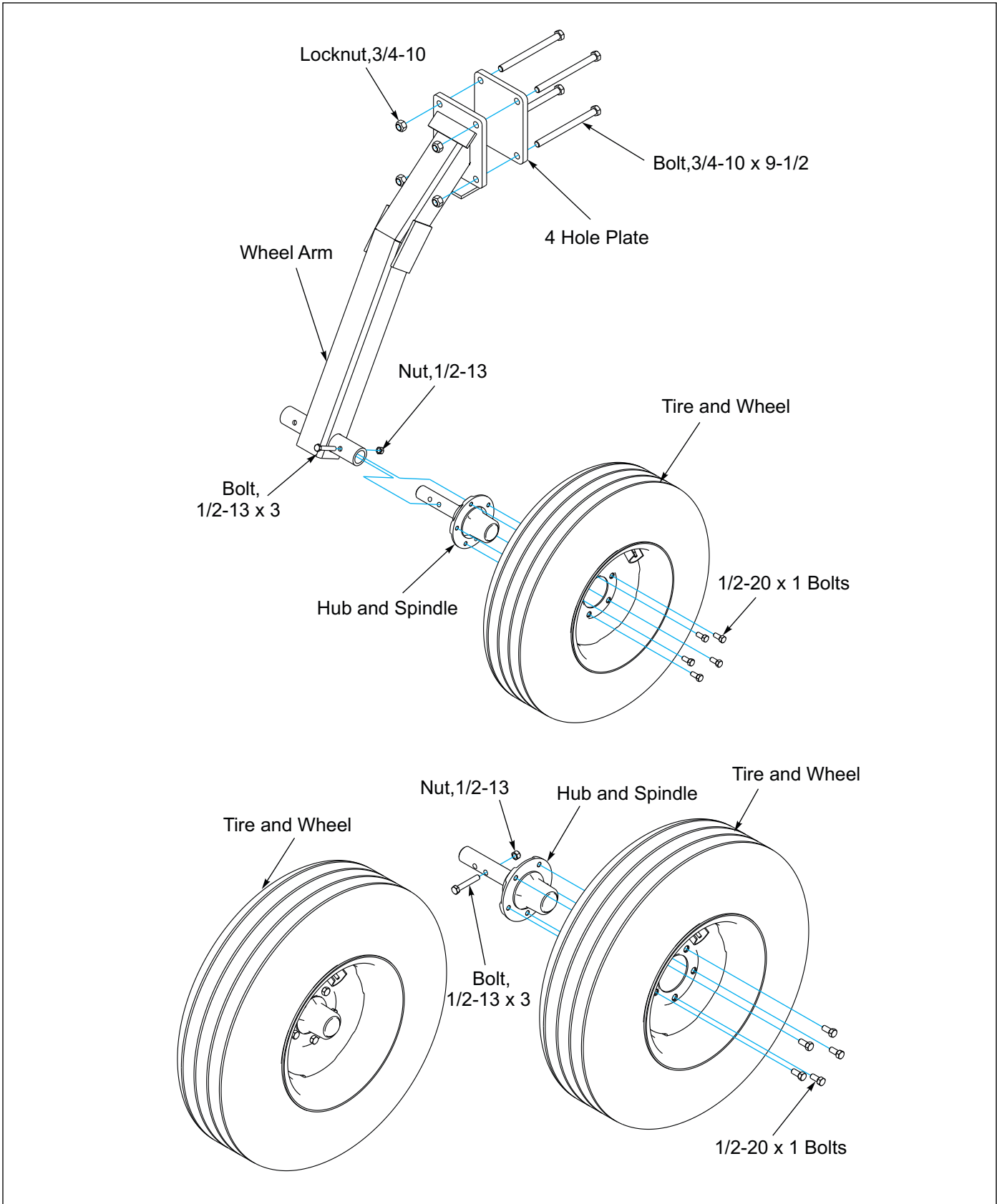

Figure 2-10: Wheel Kits

Chapter 3

Operation

NOTE

This chapter will cover the basic operation and procedures for the Brillion Floating Ring Pulverizer. Be sure to read and understand the Safety Procedures and Cautions starting on page 1-2.

Before operating your Brillion machine check all hardware for tightness. Use the Torque Tightening Chart as a guide. **See page 4-1.**



WARNING

Escaping hydraulic fluid can cause serious personal injury. Relieve system pressure before repairing, adjusting, or disconnecting. Wear proper hand and eye protection when searching for leaks. Use cardboard instead of hands. Keep all components (cylinders, hoses, fittings, etc.) in good repair

NOTE

Prevent wheel breakage by reducing speed when operating in rocky conditions.



WARNING

Maximum road speed is 20 MPH under good conditions. Do not tow the machine at a speed which makes vehicle control difficult.

If the weight of the towing vehicle is:

*equal to or greater than the equipment being towed, **MAXIMUM** road speed is 20 MPH.*

*less than the weight of the equipment but greater than half the weight of the equipment being towed, **MAXIMUM** road speed is 10 MPH.*

*less than half the weight of the equipment to be towed, **DO NOT TOW.***



CAUTION

Do not stand between the two pieces of equipment when attaching to the drawbar unless they are not moving.

NOTE

During field operations, it is not necessary to raise the machine for turns, but turns should be made as wide as possible.

The PFT Pulverizer is designed to be pulled behind tractors, seeders, or tillage tools. The long drawbar allows for easy turns when pulled behind other equipment.

When attaching the pulverizer to a tractor or implement whose drawbar height is less than 30 inches, locate the drawbar jack on the 1st or 2nd jack swivel mount closest to the front of the drawbar. **See Figure 3-1.**

If you need to attach your pulverizer to a drawbar which is higher than 30" such as a Brillion Land Commander, use the 3rd jack swivel mount near the center of the drawbar. **See Figure 3-2.**

DRAWBAR JACK POSITION

DRAWBAR JACK MOUNTED ON 1ST JACK SWIVEL

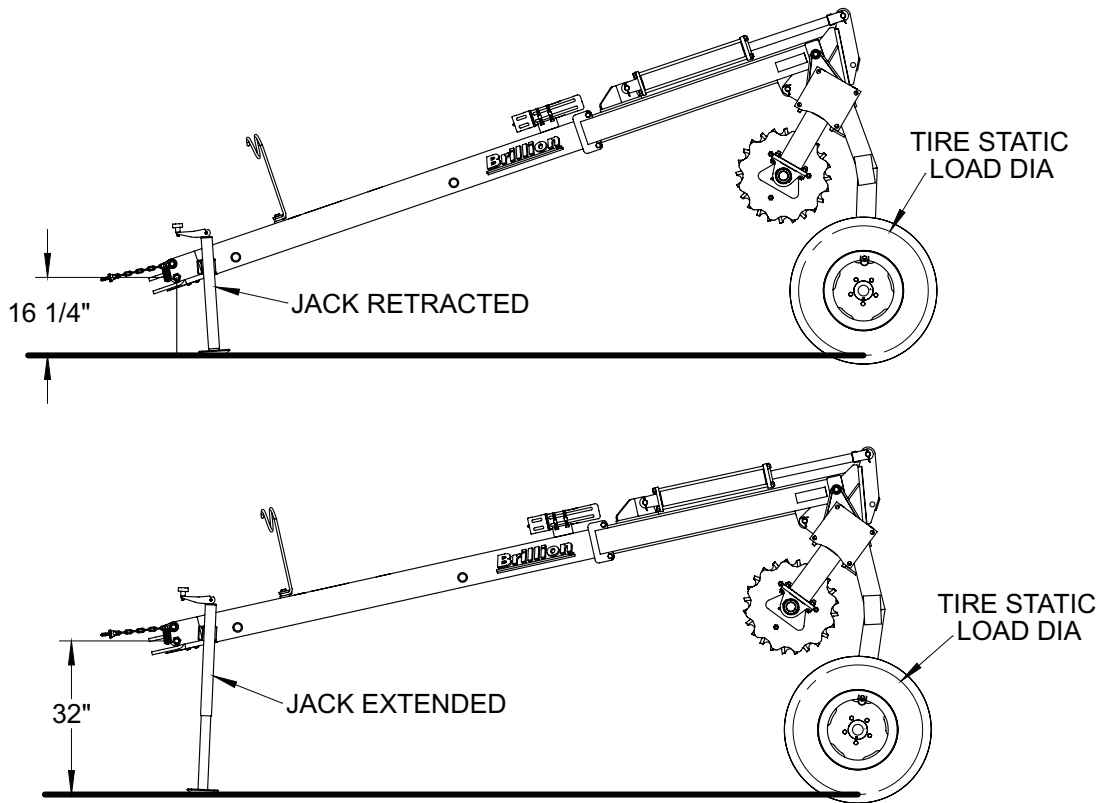
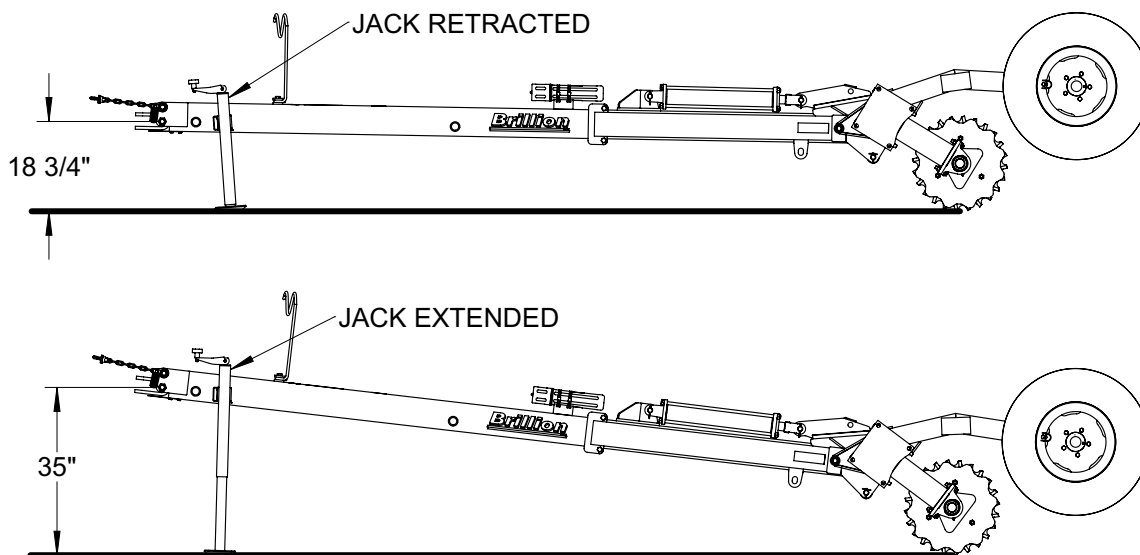

Figure 3-1: 1st Jack Swivel Position

DRAWBAR JACK POSITION

DRAWBAR JACK MOUNTED ON 2ND JACK SWIVEL



DRAWBAR JACK MOUNTED ON 3RD JACK SWIVEL

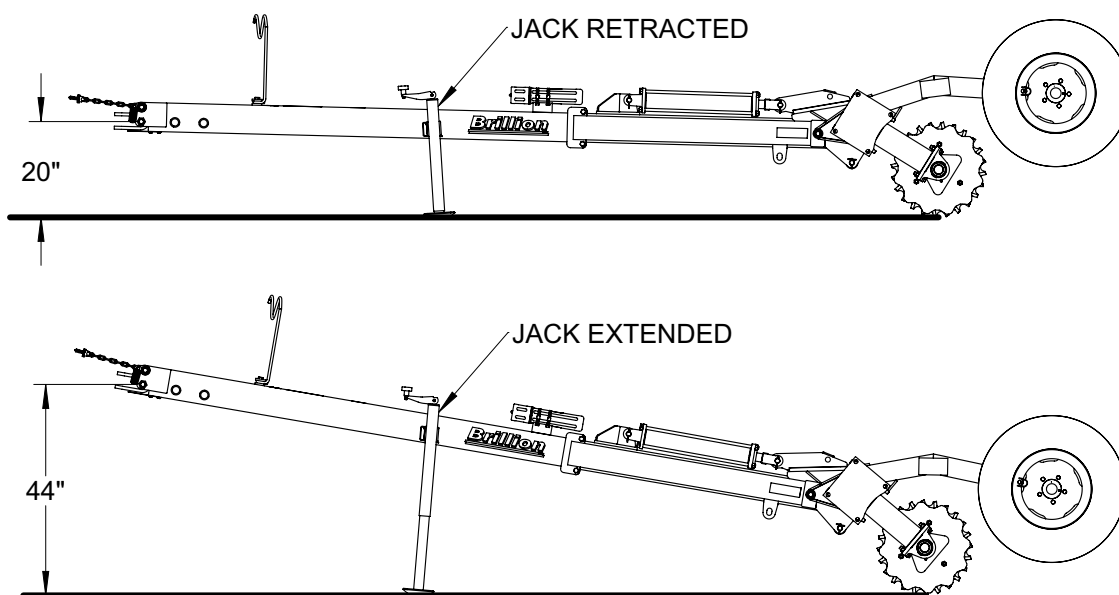

Figure 3-2: 2nd and 3rd Jack Swivel Positions

Parking

The safest way to park your pulverizer is to lower it into the operating position, place blocks behind and in front of the pulverizer wheels, then use the jack to take the weight off the towing implement and unhitch the machine

Attaching to Equipment

To attach it to equipment, reverse the above procedure. When attaching to a piece of equipment with a high drawbar, back the equipment near the pulverizer with the hitches in line, then lower the towing implement as much as you can while still being able to move it, raise the pulverizer drawbar to the desired height, bring the towing equipment into the final location, attach the pulverizer to the other machine. Then return both pieces of equipment to their transport position and install Transport Lock Pin. **See Figure 3-3.**

Transport Lock



CAUTION

Be sure to install the transport lock pin any time the pulverizer is being pulled or stored in the transport position.

If you must store the pulverizer in the transport position, block the transport wheels, use the jack to relieve weight from the towing equipment, unhitch the pulverizer, and lower the jack to make it more stable. **Figure 3-3.** shows how and where to install the transport lock pin, and also shows the storage location for the pin when it is not being used.

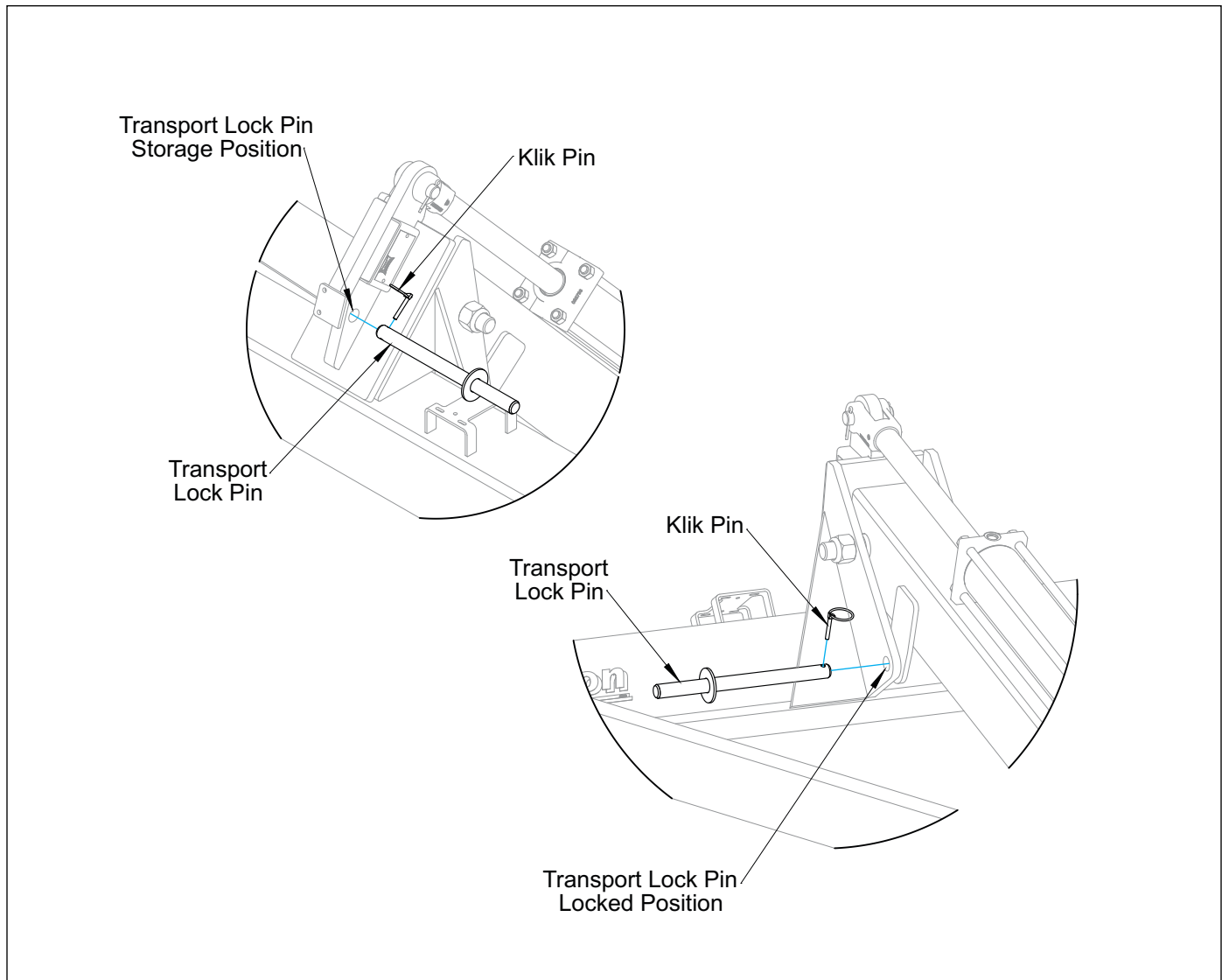

Figure 3-3: Transport Lock

Field Operations

The floating ring pulverizer is designed with rings whose inside diameter is greater than the drum which supports them. This allows the roller wheels to follow the irregular contours in your fields.

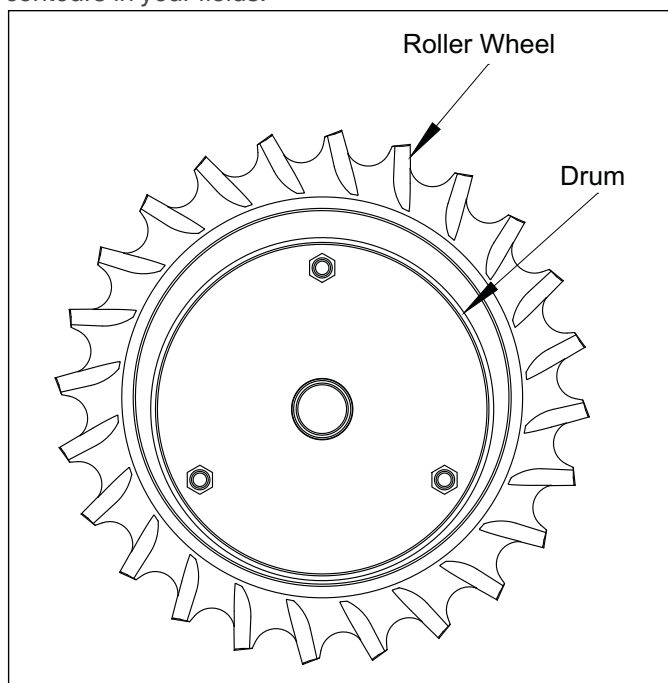

Figure 3-4: Floating Rings

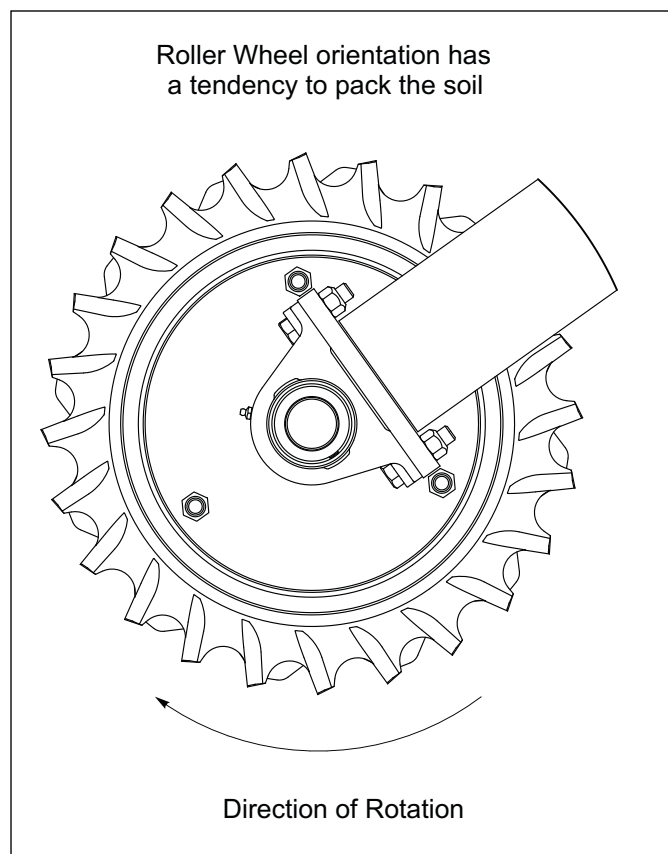

Figure 3-5: Pack Soil

Roller Orientation

The drum assembly can be mounted to the frame in two ways. When mounted as shown the wheels will have a tendency to pack the soil. **See Figure 3-5.** When the wheels are reversed they will act more like a rotary hoe and will have a tendency to loosen the soil. **See Figure 3-6.** To change the mounting of the wheel and drum assembly to the frame, follow these steps:

1. Lower the wheels to the ground.
2. Support the frame with an overhead hoist.
3. Remove the bolts which hold the Pillow Block Bearing.
4. Raise the frame above the roller assembly.
5. Pivot the roller assembly 180 degrees
6. Re-attach the Pillow Block Bearing to the bearing supports.

See "Replacing or Adding Roller Wheels" on page 4-4.

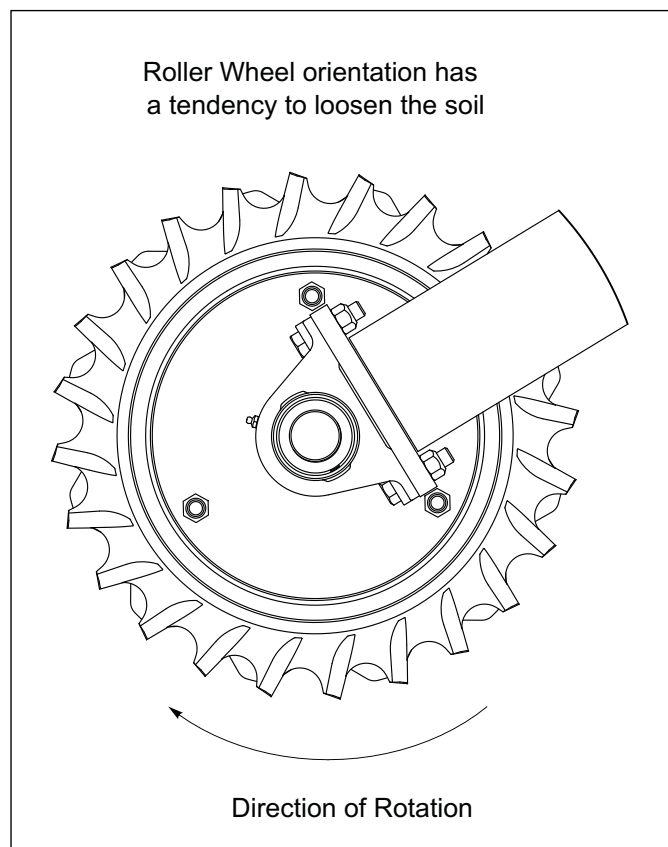

Figure 3-6: Loosen Soil

Reflectors and SMV Sign

Reflectors and a slow moving vehicle sign (SMV) are required if the Floating Ring Pulverizer is transported on a public road. Check with local laws/ordinances.

NOTICE

When Transporting on Roadways, Obey all Applicable Laws and Regulations.

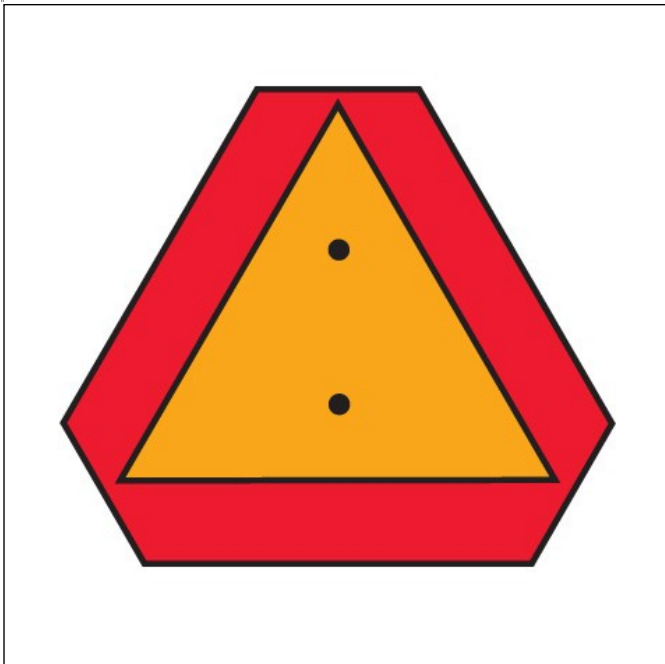

Figure 3-7: SMV Sign

LED 7-Pin Connector

- Make sure the tractor has a good clean receptacle, free of dirt and corrosion.
- Make sure the 7-pin connector is inserted ALL the way in. With tighter fitting pins, operator may think the connector is all the way in, but really isn't.
- Make sure the tractor receptacle cover latches over the keyway on the 7-pin connector to hold the connector in place.

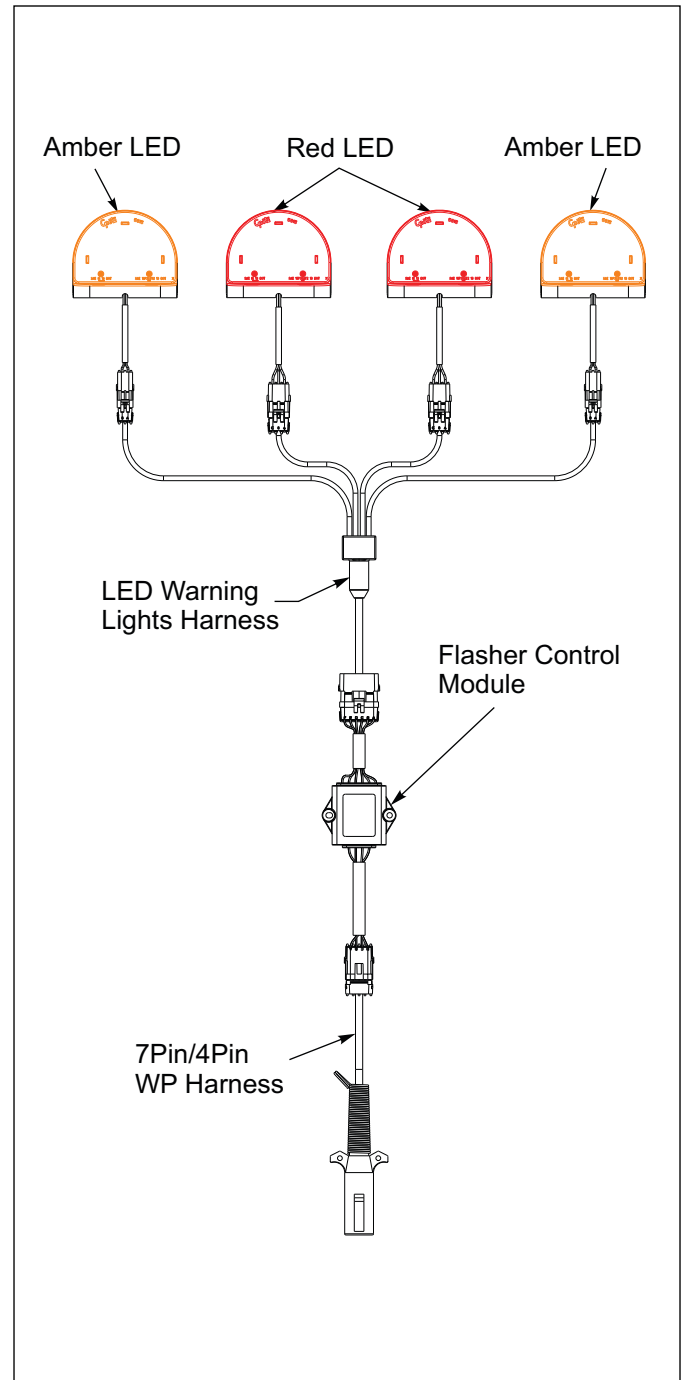

Figure 3-8: AG Harness

Maintenance

General Torque Specifications

(rev. 4/97)

This chart provides tightening torques for general purpose applications when special torques are not specified on process or drawing. Assembly torques apply to plated nuts and capscrews assembled without supplemental lubrication (as received condition). They do not apply if special graphite moly-disulfide or other extreme pressure lubricants are used. When fasteners are dry (solvent cleaned) add 33% to as received condition torque. Bolt head identification marks indicate grade and may vary from manufacturer to manufacturer. Thick nuts must be used on grade 8 capscrews. Use value in [] if using prevailing torque nuts

TORQUE SPECIFIED IN FOOT POUNDS

UNC SIZE	SAE Grade 2	SAE Grade 5	SAE Grade 8	UNF SIZE	SAE Grade 2	SAE Grade 5	SAE Grade 8
1/4-20	4 [5]	6 [7]	9 [11]	1/4-28	5 [6]	7 [9]	10 [12]
5/16-18	8 [10]	13 [13]	18 [22]	5/16-24	9 [11]	14 [17]	20 [25]
3/8-16	15 [19]	23 [29]	35 [42]	3/8-24	17 [21]	25 [31]	35 [44]
7/16-14	24 [30]	35 [43]	55 [62]	7/16-20	27 [34]	40 [50]	60 [75]
1/2-13	35 [43]	55 [62]	80 [100]	1/2-20	40 [50]	65 [81]	90 [112]
9/16-12	55 [62]	80 [100]	110 [137]	9/16-18	60 [75]	90 [112]	130 [162]
5/8-11	75 [94]	110 [137]	170 [212]	5/8-18	85 [106]	130 [162]	180 [225]
3/4-10	130 [162]	200 [250]	280 [350]	3/4-16	150 [188]	220 [275]	320 [400]
7/8-9	125 [156]	320 [400]	460 [575]	7/8-14	140 [175]	360 [450]	500 [625]
1-8	190 [237]	408 [506]	680 [850]	1-14	210 [263]	540 [675]	760 [950]
1-1/8-7	270 [337]	600 [750]	960 [1200]	1-1/8-12	300 [375]	660 [825]	1080 [1350]
1-1/4-7	380 [475]	840 [1050]	1426 [1782]	1-1/4-12	420 [525]	920 [1150]	1500 [1875]
1-3/8-6	490 [612]	1010 [1375]	1780 [2225]	1-3/8-12	560 [700]	1260 [1575]	2010 [2512]
1-1/2-6	650 [812]	1460 [1825]	2360 [2950]	1-1/2-12	730 [912]	1640 [2050]	2660 [3325]

METRIC:

Coarse thread metric class 10.9 fasteners and class 10.0 nuts and through hardened flat washers, phosphate coated, Rockwell "C" 38-45. Use value in [] if using prevailing torque nuts

Nominal thread diameter (mm)	Newton Meters (Standard Torque)	Foot Pounds (Standard Torque)	Nominal Thread Diameter (mm)	Newton Meters (Standard Torque)	Foot Pounds (Standard Torque)
6	10 [14]	7 [10]	20	385 [450]	290 [335]
7	16 [22]	12 [16]	24	670 [775]	500 [625]
8	23 [32]	17 [24]	27	980 [1105]	730 [825]
10	46 [60]	34 [47]	30	1330 [1470]	990 [1090]
12	80 [125]	60 [75]	33	1790 [1950]	1340 [1450]
14	125 [155]	90 [115]	36	2325 [2515]	1730 [1870]
16	200 [240]	150 [180]	39	3010 [3210]	2240 [2380]
18	275 [330]	205 [245]			

Hydraulic Fitting Torque Specifications

37 degree JIC, ORS, &ORB (REV. 10/97)

This chart provides tightening torques for general purpose applications when special torques are not specified on process or drawing. Assembly torques apply to plated nuts and capscrews assembled without supplemental lubrication (as received condition). They do not apply if special graphite moly-disulfide or other extreme pressure lubricants are used. When fasteners are dry (solvent cleaned) add 33% to as received condition torque. Bolt head identification marks indicate grade and may vary from manufacturer to manufacturer. Thick nuts must be used on grade 8 capscrews. Use value in [] if using prevailing torque nuts

TORQUE SPECIFIED IN FOOT POUNDS

PARKER® BRAND FITTINGS

Dash Size	37 Deg. JIC	O-ring (ORS)	O-ring Boss
-4	11-13	15-17	13-15
-5	14-16	-----	21-23
-6	20-22	34-36	25-29
-8	43-47	58-62	40-44
-10	55-65	100-110	58-62
-12	80-90	134-146	75-85
-16	115-125	202-218	109-121
-20	160-180	248-272	213-237
-24	185-215	303-327	238-262
-32	250-290	-----	310-340

GATES® BRAND FITTINGS

Dash Size	37 Deg. JIC	O-ring (ORS)	O-ring Boss
-4	10-11	10-12	14-16
-5	13-15	-----	-----
-6	17-19	18-20	24-26
-8	34-38	32-40	37-44
-10	50-56	46-56	50-60
-12	70-78	65-80	75-83
-14	-----	65-80	-----
-16	94-104	92-105	111-125
-20	124-138	125-140	133-152
-24	156-173	150-180	156-184
-32	219-243	-----	-----

AEROQUIP® BRAND FITTINGS

Dash Size	37 Deg. JIC	O-ring (ORS)	O-ring Boss
-4	11-12	10-12	14-16
-5	15-16	-----	16-20
-6	18-20	18-20	24-26
-8	38-42	32-35	50-60
-10	57-62	46-50	75-80
-12	79-87	65-70	125-135
-14	-----	-----	160-180
-16	108-113	92-100	200-220
-20	127-133	125-140	210-280
-24	158-167	150-165	270-360

Fasteners

Before operating your Brillion machine, check all hardware for tightness. (See “General Torque Specifications” on page 4-1.)

After a few hours of use, check entire machine and tighten any loose nuts or bolts. Daily or periodic checks should be made thereafter.

When replacing bolts, be sure to use fasteners of equal grade.

IMPORTANT

- If pre-assembled parts or fasteners are temporarily removed, remember where they go. It is best to keep the parts separated.
- Check that all working parts move freely, bolts are tight and cotter pins are spread.

Lubrication

Lubricate bearings with quality grease per recommended lubrication frequency intervals indicated or if machine is not used for an extended period. Greasable components are the same on each side.

Lubricating Wheel Hub: Grease Wheel Hubs every 50 hours.

Repack Wheel Hub bearings annually before each season usage. See Figure 4-1.



CAUTION

Over lubrication of these bearings can cause premature bearing failure.

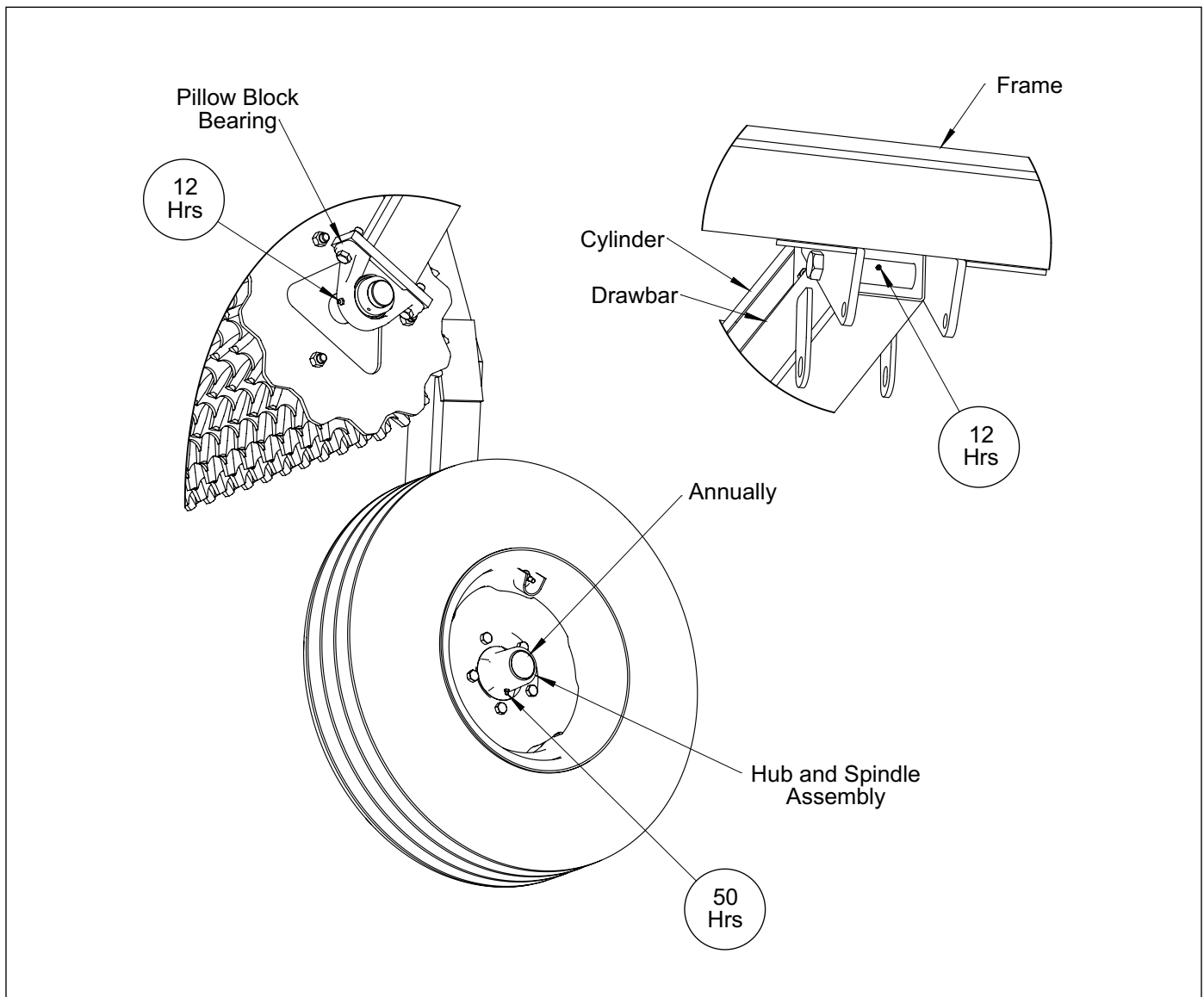

Figure 4-1: Tire and Hub Lubrication

Tires



CAUTION

Use of smaller or lighter tires will cause premature tire failure and may cause an accident.

All machines are shipped with 15 x 8LB, 6 Bolt Wheels which require 11L - 15 - 8 Ply Tires. Inflate to 36 PSI. After several hours of use re-torque Wheel Bolts 90-100 Ft-Lbs. For tightening sequence, **See Figure 4-2.**

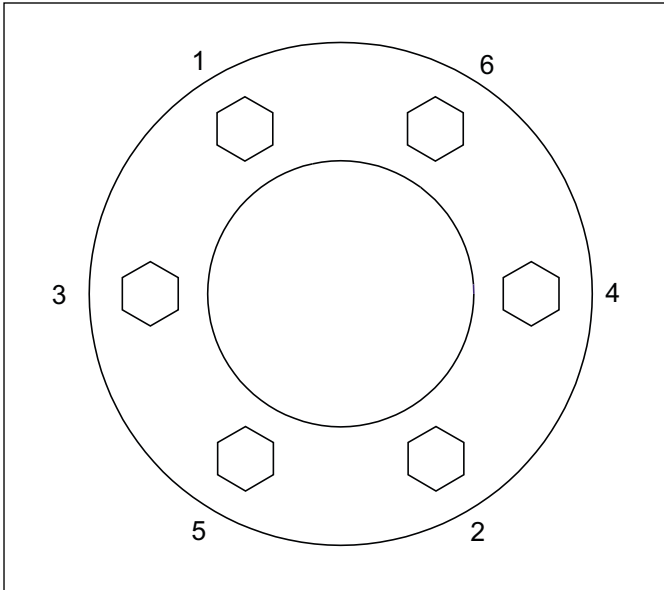

Figure 4-2: Wheel Bolt Tightening Sequence



CAUTION

Escaping fluid under pressure can be nearly invisible and have enough force to penetrate the skin causing serious injury. Use a piece of cardboard, rather than hands to search for suspected leaks. Wear protective gloves and safety glasses or goggles when working with the hydraulic system.

Hydraulic System

The first time the machine is connected to the tractor, or any time the hydraulic circuit is opened, air must be bled from the system

Check the hydraulic lines and cylinders for leaks before starting operation each day.

When the machine is not to be used for some time, exposed portions of the cylinder rods should be cleaned and covered with a thin coat of grease. This will prevent corrosion which will damage cylinder seals.

Replacing or Adding Roller Wheels

Although the roller wheels are manufactured from high grade ductile iron, wear or breakage may require that some wheels be periodically replaced. Follow these steps when replacing wheels.

1. Attach a tractor to the Pulverizer, put the tractor transmission into PARK or lock the brakes preventing tractor from moving. Hydraulically raise the Pulverizer to the transport position and insert the transport pin. With the pulverizer in the transport position, slide all the wheels toward one end of the drum. Remove the transport pin and lower the machine so that the roller wheels rest on blocks approximately two inches off the ground. **See Figure 4-3.** Continue to lower the machine until the outside of the roller drum contacts the bottom ring of the roller wheels.
2. Remove the Pillow Block Bearing and the Bearing Support from the end of the Drum to which you will be replacing or adding Wheels. The Pillow Block Bearing is secured to the Drum Shaft by means of an Eccentric Locking Collar. Loosen the set screws which tighten the Eccentric Locking Collar to the shaft. Then with a punch, rotate the Eccentric Locking Collar in the direction opposite which the shaft turns in normal operation. Next remove the Locknuts from the 5/8-11 x 9-1/2 Bolts which mount the Bearing Supports to the Frame and slide the bearing and the support off the shaft. Remove the three 5/8-11 Locknuts which attach the retainer plate to the drum and remove.
3. Remove damaged wheels. Slide the replacement wheels onto the drum, ensuring that they are oriented in the same direction as the others. Re-attach the Retainer Wheel using the three 5/8-11 Locknuts. Tighten.
4. Slide the Pillow Block Bearing and Bearing Support onto the Drum Shaft until the bearing bottoms against shaft shoulder. Re-attach Roller Assembly to the Frame by installing 5/8-11 x 9-1/2 Bolts and Locknuts. Tighten. Now take a punch and rotate the Eccentric Locking Collar of the bearing in the direction which the bearing will rotate and tighten the set screw against the shaft.
5. Hydraulically raise the Pulverizer to the transport position and insert the transport pin.

Refer to “**General Torque Specifications**” on **page 4-1.** for proper bolt torque values. Note the different torque requirement for bolts with lock nuts.

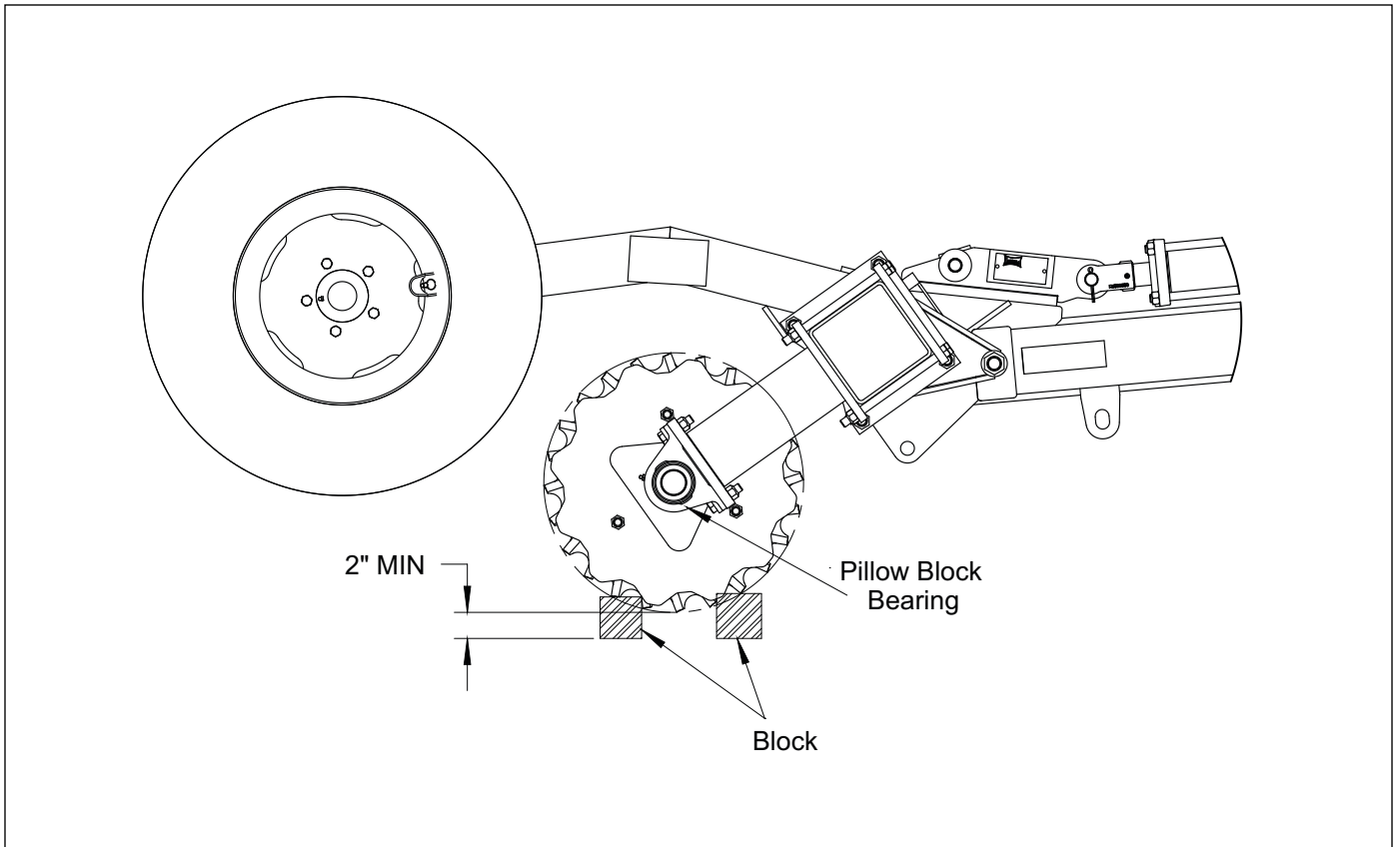

Figure 4-3: Pillow Block Bearing

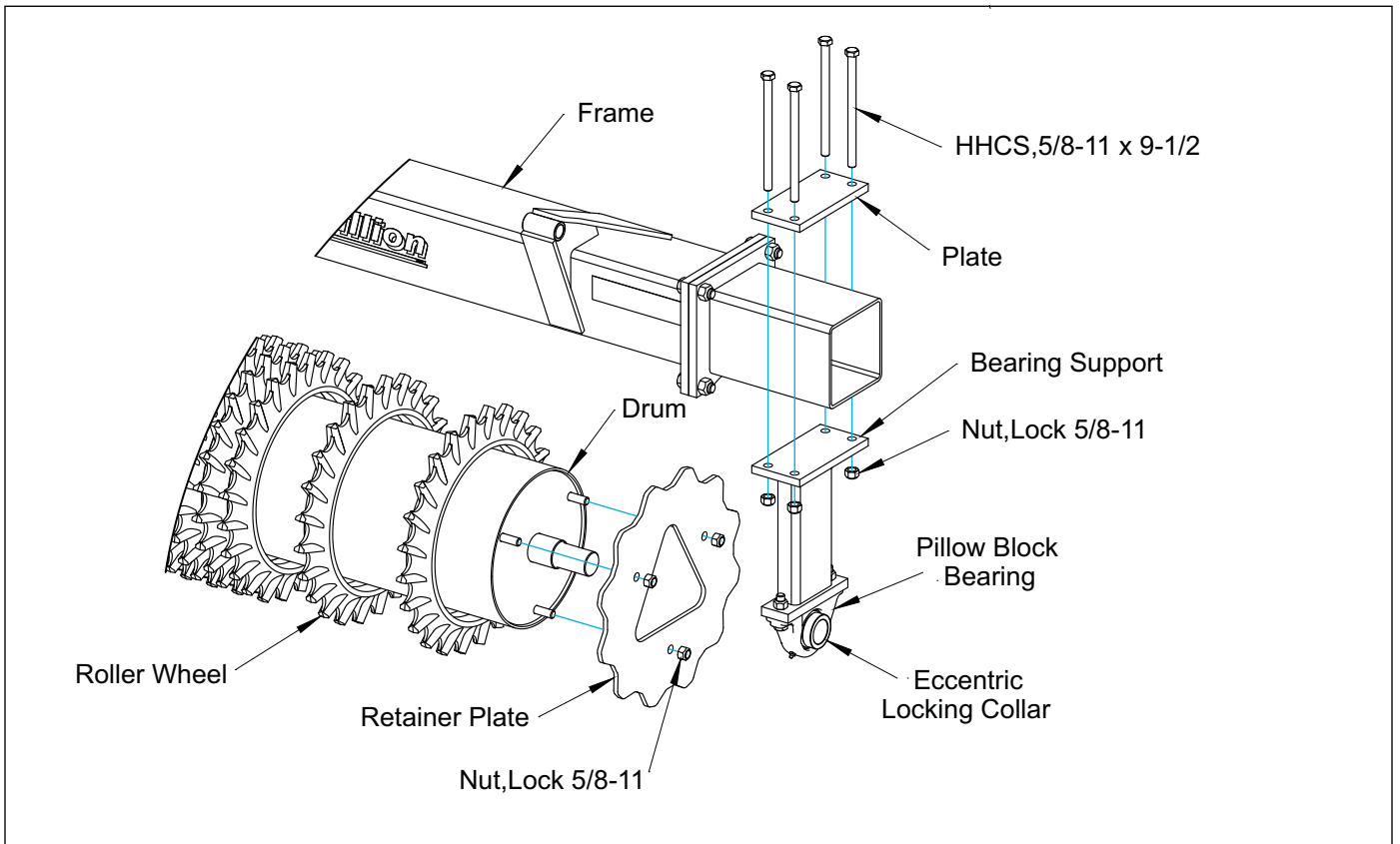

Figure 4-4: Roller Wheels Removal

General Reference and Specifications

Table 5-1: Specifications

Standard Machine Specifications		
7" x 7" Main Frame	Cat. II, III Three-Point Hitch	11L x 15-8 Ply Tire on Pull-Type Models
1 15/16 Pillow Block bearings	Overall Length (Transport) 12' 6"	Overall Length (Operation) 15' 4"
Safety Warning Lights & SMV Emblem	Safety Chain	Powder Coat Paint

Accessories & Optional Equipment	
Part Number	Description
5K168	Dual Wheel Kit for Pull-Type Models (Includes 2 - 11L x 15 8 Ply Tires)
5K167	Single Wheel Kit for Pull-Type Models (Includes 1 - 11L x 15 8 Ply Tires)

Document Control Revision Log:

Date	Revision	Improvement(s) Description and Comments	Team Member
02/2015	0215	Updated Drawings	WML



Intertek

Equipment from Landoll Company, LLC is built to exacting standards ensured by ISO 9001 registration at all Landoll manufacturing facilities.

Floating Ring Pulverizer PF-PFT 10' through 18' Models Operator's Manual

Re-Order Part Number 5K089rev0215

LANDOLL COMPANY, LLC

1900 North Street

Marysville, Kansas 66508

(785) 562-5381

800-428-5655 ~ WWW.LANDOLL.COM



Copyright 2020. Landoll Company, LLC

"All rights reserved, including the right to reproduce this material or portions thereof in any form"