

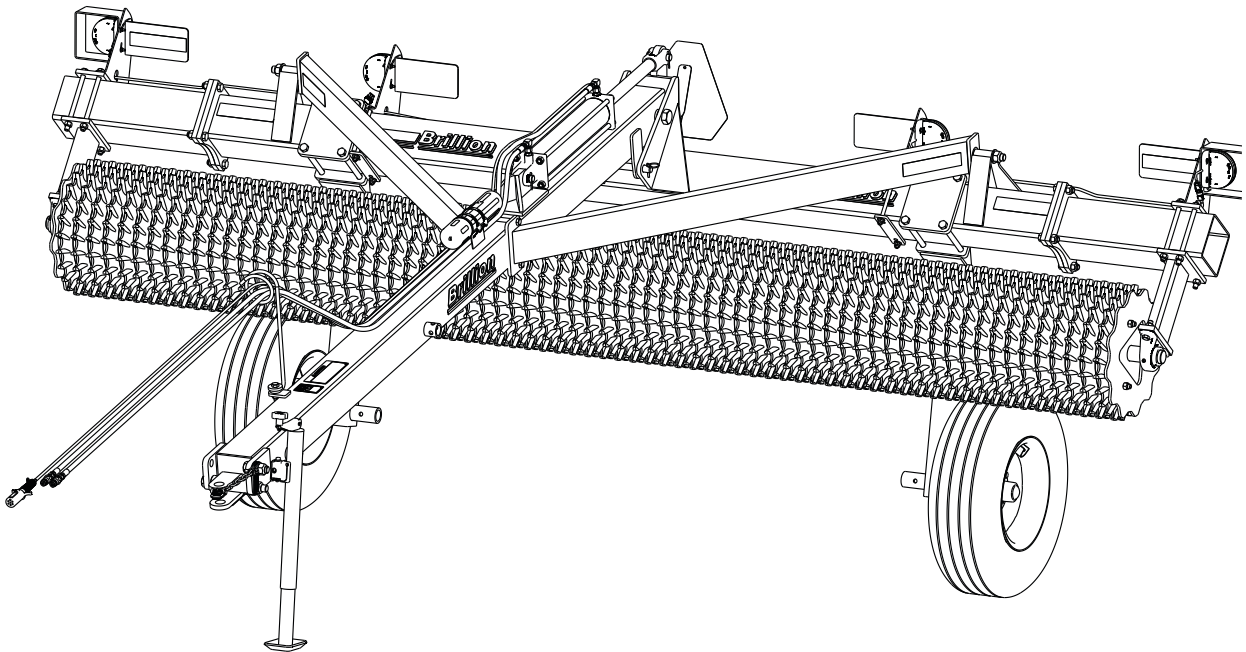

# Floating Ring Pulverizer PFT 10' through 18' Models Parts Manual



## **LANDOLL COMPANY, LLC**

1900 North Street  
Marysville, Kansas 66508  
(785) 562-5381

800-428-5655 ~ [WWW.LANDOLL.COM](http://WWW.LANDOLL.COM)



# Table of Contents

---

## 1 Illustrated Parts List

<b>Instructions for Ordering Parts</b> .....	<b>1-1</b>
ID Plate .....	1-1
Frame and Wheel Arms .....	1-2
Hub and Spindle .....	1-4
Wheel Assembly .....	1-5
Dual Wheel Kit - Optional .....	1-6
Drawbar .....	1-7
Roller Bearing Hanger .....	1-9
Roller Assembly - 10' - 18' .....	1-10
Hydraulics .....	1-12
Electrical .....	1-14
Hydraulic Cylinder, 4 x 16 .....	1-16
Decals .....	1-18

## 2 Numerical Index

## 3 Glossary



## Illustrated Parts List

### Instructions for Ordering Parts

**\*\* Repair parts must be ordered through an authorized dealer \*\***

#### DEALER INSTRUCTIONS FOR ORDERING PARTS FROM LANDOLL PARTS DISTRIBUTION CENTER

PHONE #: 800-423-4320 OR 785-562-5381

FAX #: 888-527-3909

ORDER ONLINE: [Dealer.landoll.com](http://Dealer.landoll.com)

#### IDENTIFICATION PLATE

See Figure 1-1. for the Identification Plate, which lists the model and serial number of the equipment. It is located on the rear of the frame right of center of the Floating Ring Pulverizer.

#### SERIAL NUMBER NOMENCLATURE

The serial number for the Floating Ring Pulverizer is located on the identification plate. The following information will help decode the Landoll serial number.

**PXB2000101 = XXMYSSSSS**

XX	= Model Series (i.e. "PX" for all Pulverizers)
M	= Month of Manufacture (ex. "B" means February. The letter I is not used.)
YY	= Year Manufactured (ex. "20" means 2020)
SSSS	= Sequential number used to track warranty and service information.



Figure 1-1: ID Plate

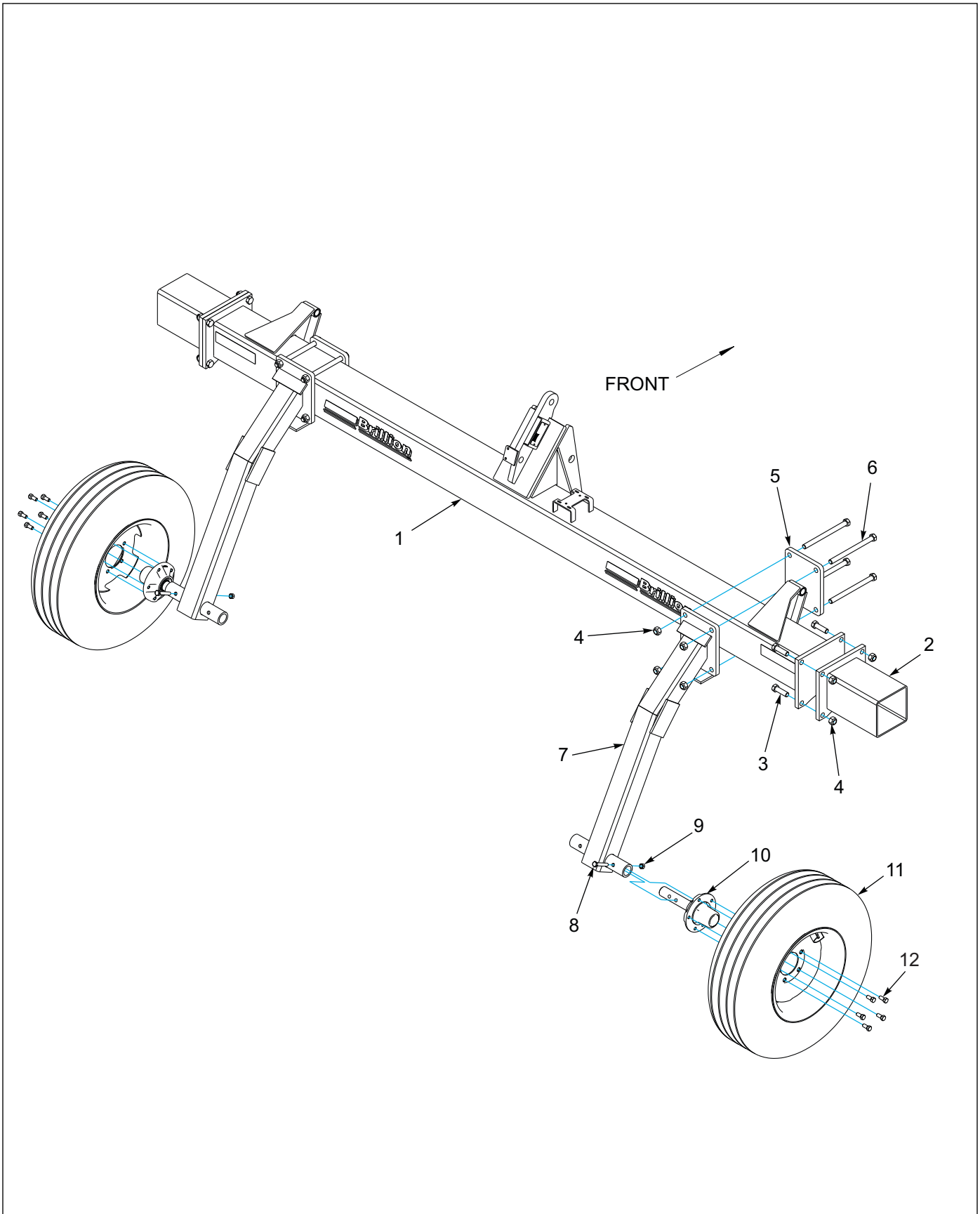

Figure 1-2: Frame and Wheel Arms

## Frame and Wheel Arms

ITEM	PART NUMBER	DESCRIPTION	QTY.
1	4K941	FRAME	1
2	4K989	EXTENSION 1 FT (12' MODELS)	2
2	4K990	EXTENSION - 2 FT (14' MODELS)	2
2	4K991	EXTENSION - 3 FT (15' AND 16' MODELS)	2
2	6K309	EXTENSION - 4 FT (17' AND 18' MODELS)	2
3	1-654-010061-07	SCREW, HX CP 3/4-10UNC X 2-1/2 G5	8
4	1-512-010005-15	NUT, HEX, SLFLKG GRB 3/4-10	16
5	5K195	PLATE	2
6	104436	SCREW, HX CP, 3/4-10UNC X 9-1/2 GR5	8
7	4K965	WHEEL ARM	2
8	1-654-010055-09	SCREW, HX CP, 1/2-13UNC X 3 GR5	2
9	1-512-010005-09	NUT, HEX SLFLKG, 1/2-13 GRB	2
10	9J331	HUB & SPINDLE ASSM (SEE FIGURE 1-3)	2
11	6K924	WHEEL 8J791/NO TUBE/6J189 (SEE FIGURE 1-4)	2
12	5C100	WHEEL BOLT 1/2-20 X 1 GR5 ZP	10
13	5K167	SINGLE WHEEL ARM KIT-PFT PULV (NOT SHOWN) (INCLUDES ITEMS 4 - 12)	

## ILLUSTRATED PARTS LIST

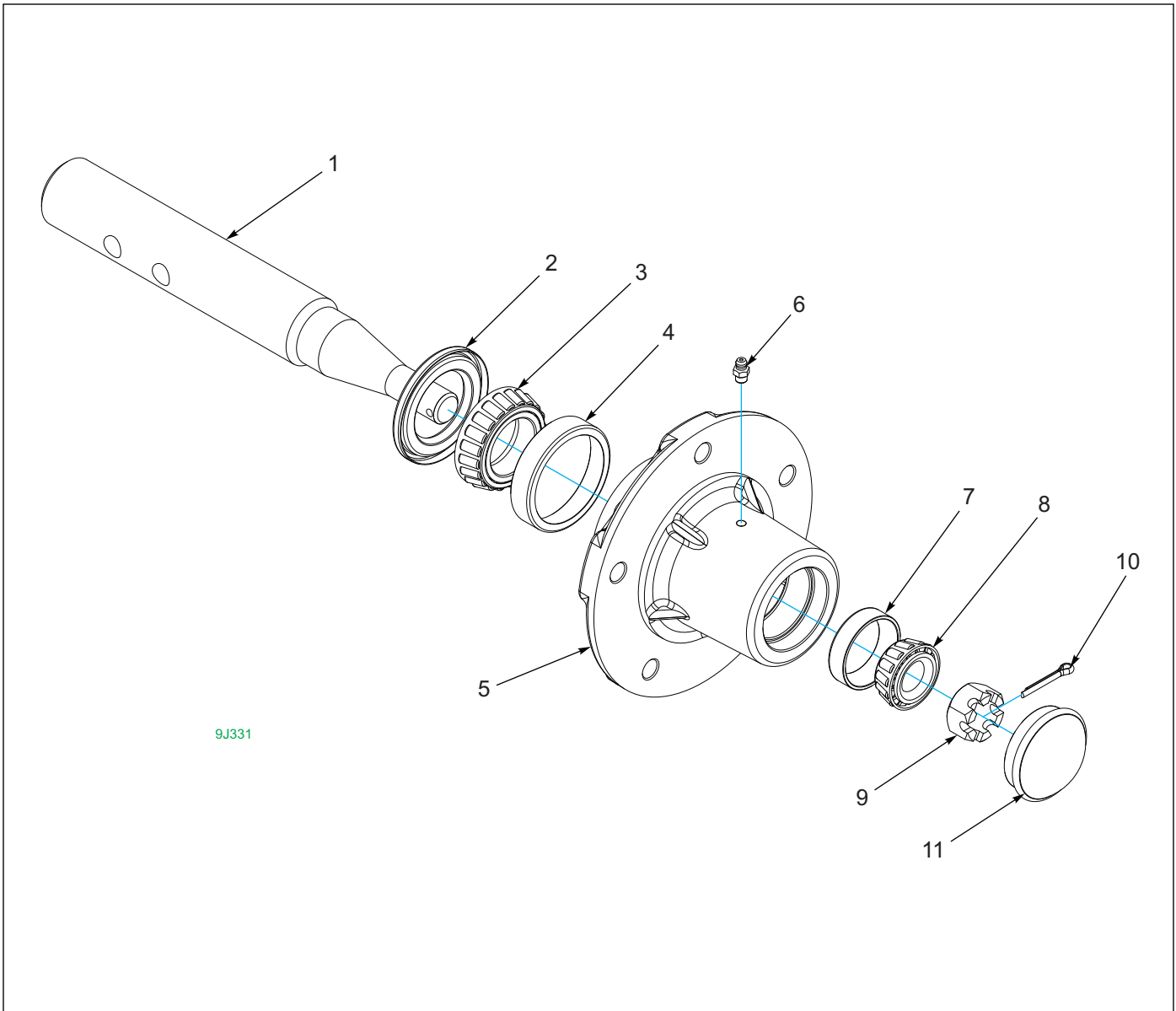

Figure 1-3: Hub and Spindle

### Hub and Spindle

ITEM	PART NUMBER	DESCRIPTION	QTY.
	9J331	HUB & SPINDLE ASSEMBLY	
1	9J330	SPINDLE	1
2	1D273	SEAL	1
3	5C480	CONE, BEARING	1
4	5C479	CUP, BEARING	1
5	1J390	WHEEL HUB - 5 BOLT (INCLUDES ITEM 6)	1
6	1-298-010001-1	ZERK FITTING 1/4 SAE	1
7	5C912	CUP, BEARING	1
8	1-076-010008	OUTER CONE 4-BOLT HUB	1
9	3/4-16HSN	HEX SLOTTED NUT	1
10	110-0344	5/32 X 1 COTTER PIN	1
11	1J463	HUB CAP	1



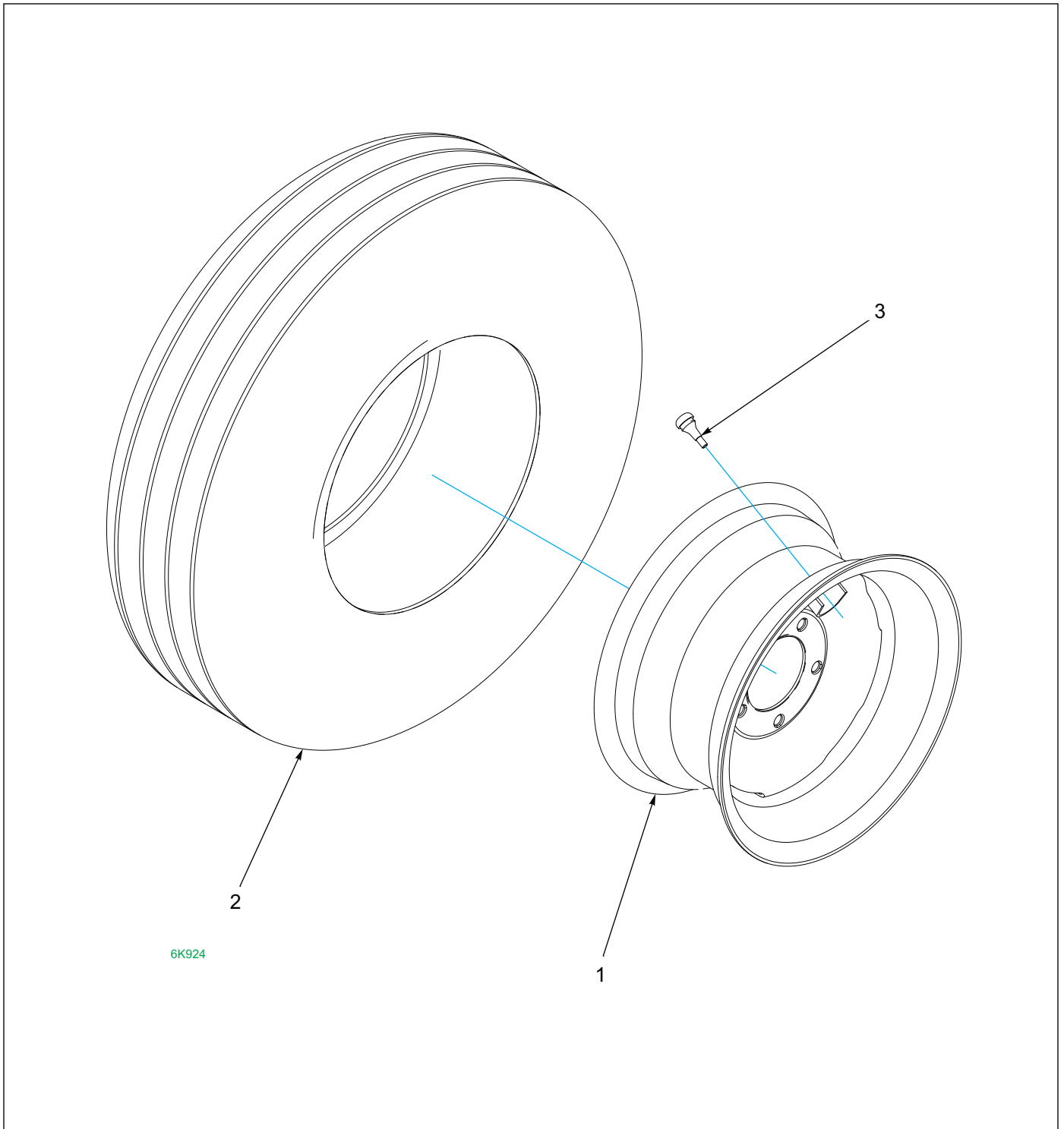

Figure 1-4: Wheel Assembly

### Wheel Assembly

ITEM	PART NUMBER	DESCRIPTION	QTY.
	6K924	WHEEL 8J791/NO TUBE/6J189	
1	6J189	WHEEL - 15 X 8LB - 5BOLT	1
2	8J791	TIRE - 11L X 15 - 8 PLY	1
3	8J792	VALVE STEM-TUBELESS	1

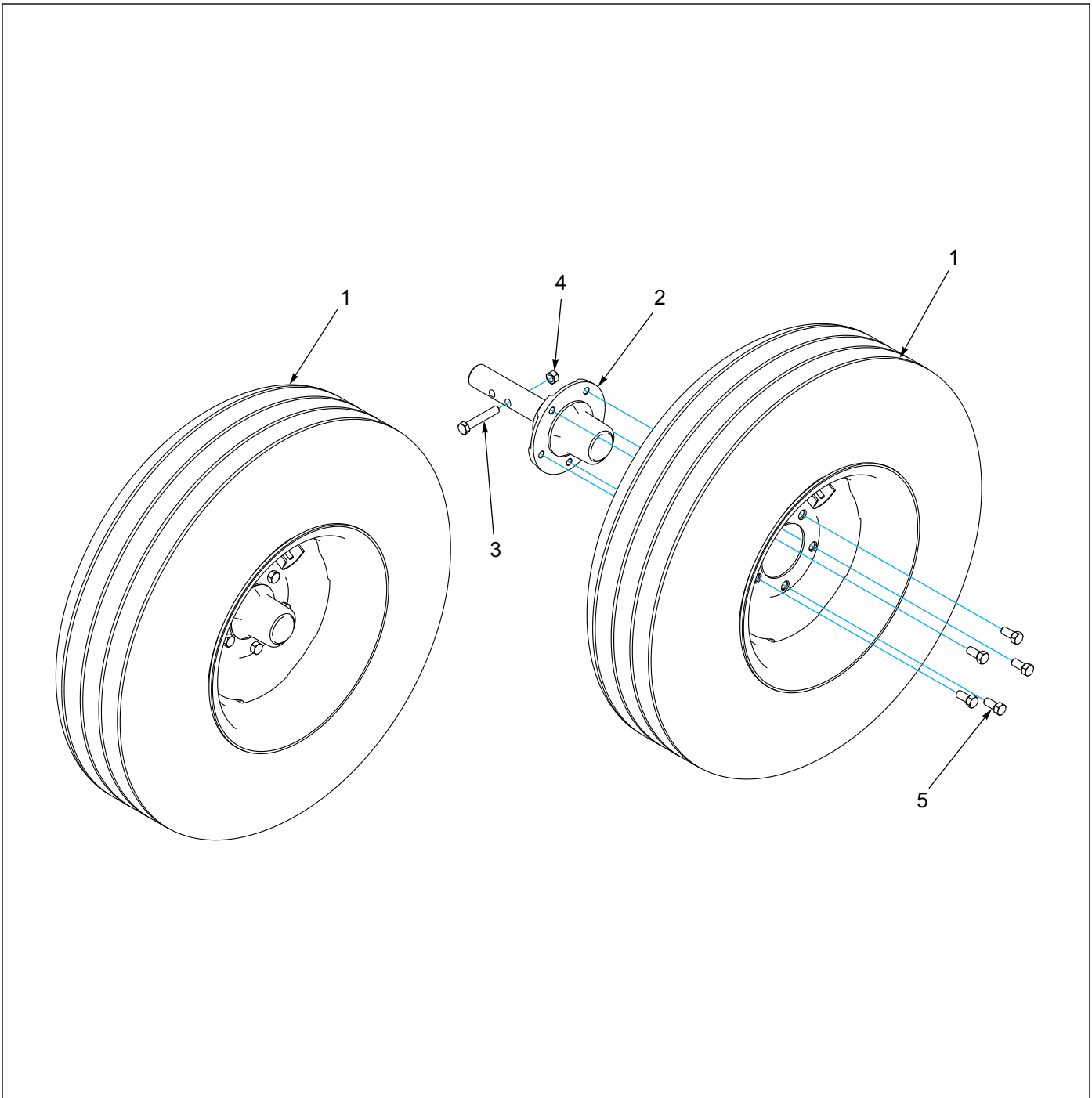

Figure 1-5: Dual Wheel Kit - Optional

**Dual Wheel Kit - Optional**

ITEM	PART NUMBER	DESCRIPTION	QTY.
	5K168	DUAL WHEEL KIT - PFT PULV	
1	6K924	WHEEL 8J791/NO TUBE/6J189 (SEE FIGURE 1-4)	2
2	9J331	HUB & SPINDLE ASSM (SEE FIGURE 1-3)	2
3	1-654-010055-09	SCREW, HX CP, 1/2-13UNC X 3 GR5	2
4	1-512-010005-09	NUT, HEX,SLFLKG, 1/2-13 GRB	2
5	5C100	WHEEL BOLT 1/2-20 X 1 GR5 ZP	10

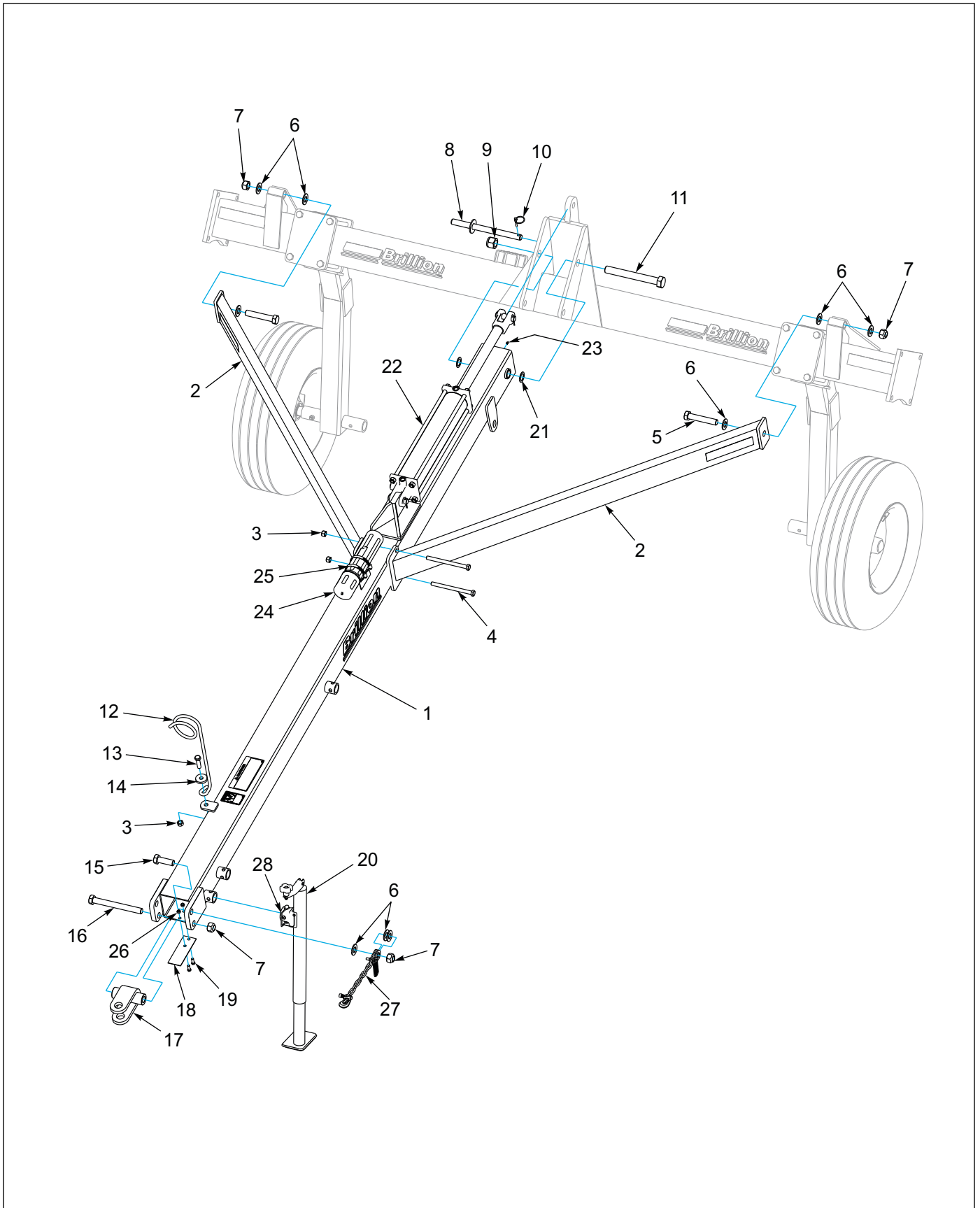

Figure 1-6: Drawbar

## ILLUSTRATED PARTS LIST

### Drawbar

ITEM	PART NUMBER	DESCRIPTION	QTY.
1	4K955	DRAWBAR ASSY	1
2	4K971	BRACE	2
3	1-512-010005-13	NUT,HEX SLFLKG GRB 5/8-11	3
4	1-654-010059-21	SCREW, HEX CAP, 5/8-11UNC X 8 GR5	2
5	102271	SCREW HX CP 1-8UNC X 5-1/2 GR5	2
6	1-861-010032-24	WASHER FL 1IN NARROW ZP	9
7	1-512-010005-19	NUT 1-8 HEX SLF-LOCKING GRB	4
8	9J015	PIN	1
9	101385	NUT,HEX SLFLKG, 1-1/4-7 GRB	1
10	1-557-010327	PIN LYNCH 1/4 X 1-1/4	1
11	7K664	BOLT, 1.25-7 X 10-1/2, GR5, ZP	1
12	6D333	HOSE SUPPORT	1
13	1-654-010059-05	SCREW, HEX CAP 5/8-11 X 2 G5	1
14	1-861-010032-18	WASHER, FLAT 5/8 SAE	1
15	3J608	HHCS, 1-8 X 3, GR5 ZP	1
16	1K557	BOLT, 1-8 X 9-1/2, GR5	1
17	9D227	CLEVIS ASSEMBLY	1
18	6D865	STRAP	1
19	1-654-010051-05	SCREW,HEX CAP 3/8-16UNC X 1 GR5	2
20	4K867	DRAWBAR JACK	1
21	4J548	MACH BUSH, 1.25 X 1.875 X 14GA	2
22	4K992	HYD CYLINDER - 4 X 16 (SEE FIGURE 1-11)	1
23	1-298-010001-1	ZERK FITTING 1/4 SAE	1
24	1-116-010019	BOX, MANUAL STORAGE	1
25	105-0093	HOSE CLAMP 4-1/2 IDEAL #5264	2
26	1-512-010005-05	NUT, HEX, SLFLKG GRB 3/8-16	2
27	141433	SAFETY CHAIN	1
28	6K458	9/16 JACK PIN W/CHAIN & SCREW	1

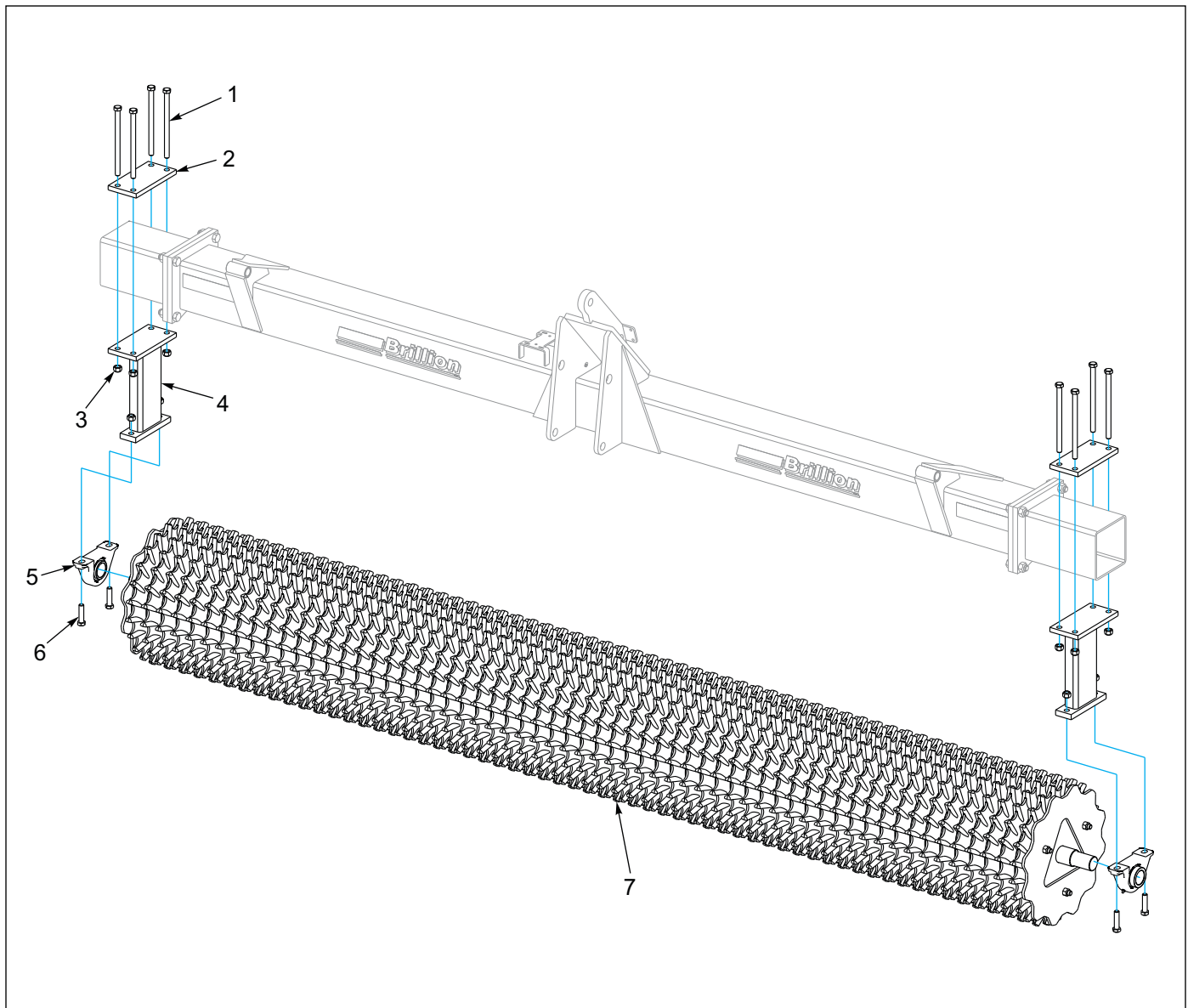

Figure 1-7: Roller Bearing Hanger

## Roller Bearing Hanger

ITEM	PART NUMBER	DESCRIPTION	QTY.
1	1-654-010059-24	SCREW HX CP 5/8-11UNC X 9-1/2	8
2	5K196	PLATE	2
3	1-512-010005-13	NUT, HEX SLFLKG GRB 5/8-11	12
4	4K959	BEARING SUPPORT	2
5	4K993	PILLOW BLOCK BEARING	2
6	1-654-010059-07	SCREW HX CP 5/8-11UNC X 2-1/2 G5	4
7	5K066	ROLLER ASSY 10-20-12 (SEE FIGURE 1-8)	1
7	5K067	ROLLER ASSY 12-20-12 (SEE FIGURE 1-8)	1
7	5K068	ROLLER ASSY 14-20-12 (SEE FIGURE 1-8)	1
7	5K069	ROLLER ASSY 15-20-12 (SEE FIGURE 1-8)	1
7	5K070	ROLLER ASSY 16-20-12 (SEE FIGURE 1-8)	1
7	1P828	ROLLER ASSY 17-20-12 (SEE FIGURE 1-8)	1
7	6K310	ROLLER ASSY 18-20-12 (SEE FIGURE 1-8)	1

## ILLUSTRATED PARTS LIST

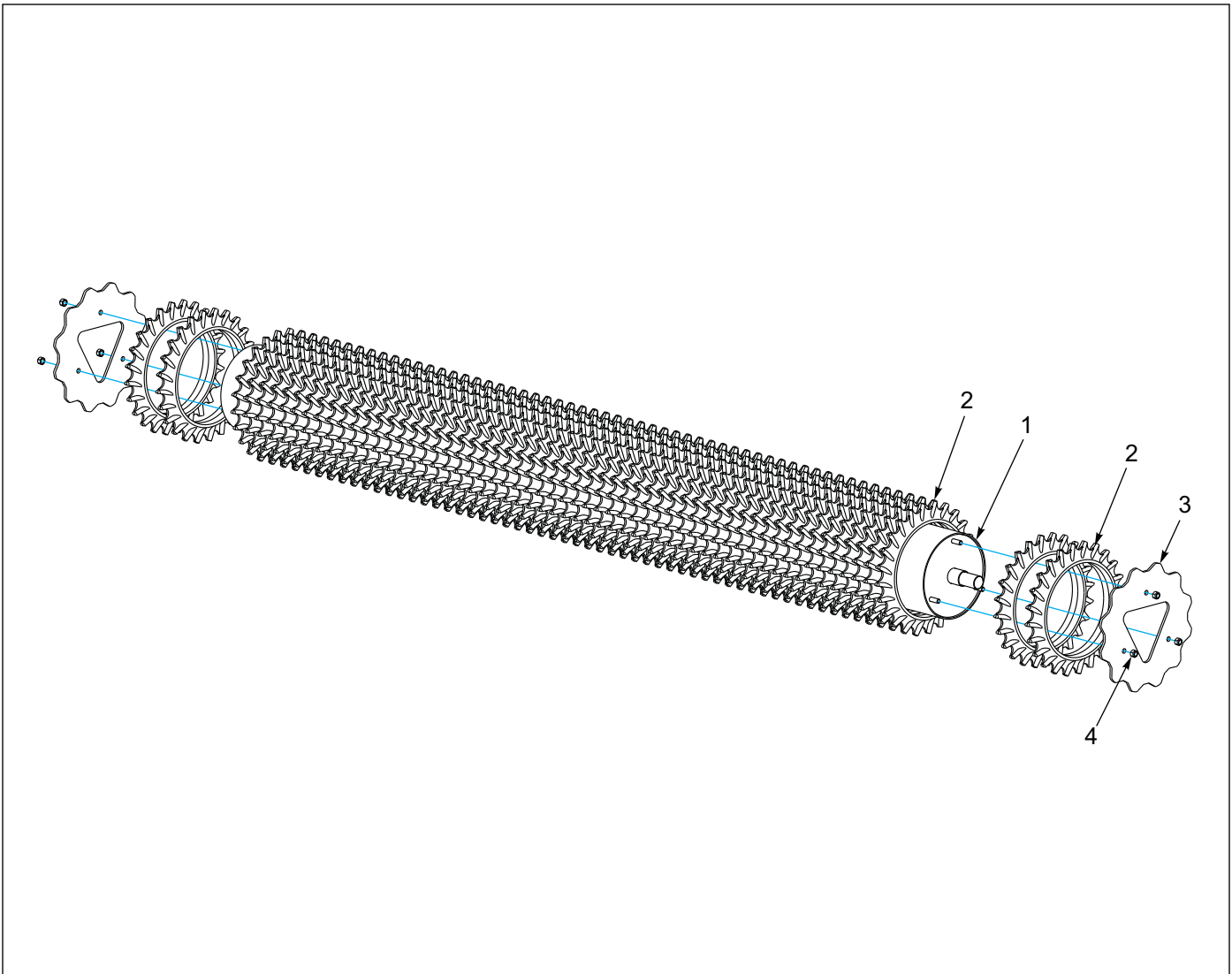

Figure 1-8: Roller Assembly - 10' - 18'

### Roller Assembly - 10'

ITEM	PART NUMBER	DESCRIPTION	QTY.
	5K066	ROLLER ASSY 10-20-12	
1	5K031	12" X 10' DRUM	1
2	4K392	20" FLOATING RING WHEEL	50
3	4K988	RETAINER - 19" DIA.	2
4	1-512-010005-13	NUT, HEX SLFLKG GRB 5/8-11	6

### Roller Assembly - 12'

ITEM	PART NUMBER	DESCRIPTION	QTY.
	5K067	ROLLER ASSY 12-20-12	
1	5K032	12" X 12' DRUM	1
2	4K392	20" FLOATING RING WHEEL	60
3	4K988	RETAINER - 19" DIA.	2
4	1-512-010005-13	NUT, HEX SLFLKG GRB 5/8-11	6

**Roller Assembly - 14'**

ITEM	PART NUMBER	DESCRIPTION	QTY.
	5K068	ROLLER ASSY 14-20-12	
1	5K033	12" X 14' DRUM	1
2	4K392	20" FLOATING RING WHEEL	70
3	4K988	RETAINER - 19" DIA.	2
4	1-512-010005-13	NUT, HEX SLFLKG GRB 5/8-11	6

**Roller Assembly - 15'**

ITEM	PART NUMBER	DESCRIPTION	QTY.
	5K069	ROLLER ASSY 15-20-12	
1	5K034	12" X 15' DRUM	1
2	4K392	20" FLOATING RING WHEEL	75
3	4K988	RETAINER - 19" DIA.	2
4	1-512-010005-13	NUT, HEX SLFLKG GRB 5/8-11	6

**Roller Assembly - 16'**

ITEM	PART NUMBER	DESCRIPTION	QTY.
	5K070	ROLLER ASSY 16-20-12	
1	5K035	12" X 16' DRUM	1
2	4K392	20" FLOATING RING WHEEL	80
3	4K988	RETAINER - 19" DIA.	2
4	1-512-010005-13	NUT, HEX SLFLKG GRB 5/8-11	6

**Roller Assembly - 17'**

ITEM	PART NUMBER	DESCRIPTION	QTY.
	1P828	ROLLER ASSEMBLY 17-20-12	
1	1P827	DRUM 12" X 17'	1
2	4K392	20" FLOATING RING WHEEL	85
3	4K988	RETAINER - 19" DIA.	2
4	1-512-010005-13	NUT, HEX SLFLKG GRB 5/8-11	6

**Roller Assembly - 18'**

ITEM	PART NUMBER	DESCRIPTION	QTY.
	6K310	ROLLER ASSEMBLY 18-20-12	
1	6K313	DRUM 12" X 18'	1
2	4K392	20" FLOATING RING WHEEL	90
3	4K988	RETAINER - 19" DIA.	2
4	1-512-010005-13	NUT, HEX SLFLKG GRB 5/8-11	6

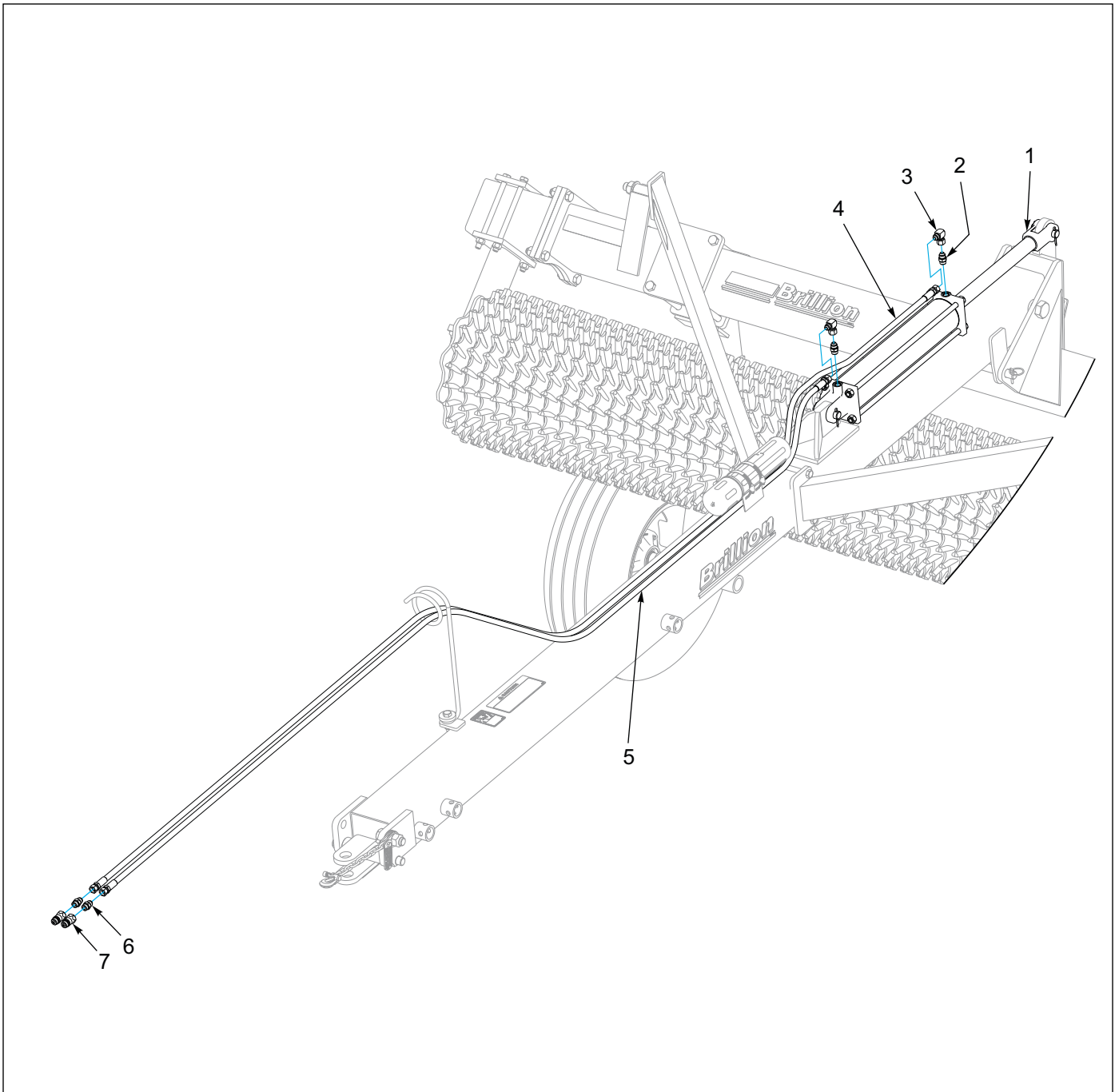

Figure 1-9: Hydraulics

## Hydraulics

ITEM	PART NUMBER	DESCRIPTION	QTY.
1	4K992	HYD CYLINDER - 4 X 16 (SEE FIGURE 1-11)	1
2	4K607	RESTRICTOR	2
3	2071-8-8S	ADAPTER 90 #8 FLR SWVL #8 JIC	2
4	150273	HOSE ASSY 3/8 X 185 #8 JIC SWVL	1
5	159569	HOSE ASSY 3/8 X 161,#8 JIC SWVL	1
6	202702-8-8S	ADAPTER #8 O-RING TO #8 TUBE	2
7	141828	COUPLER MALE 3/4-16 O-RING	2





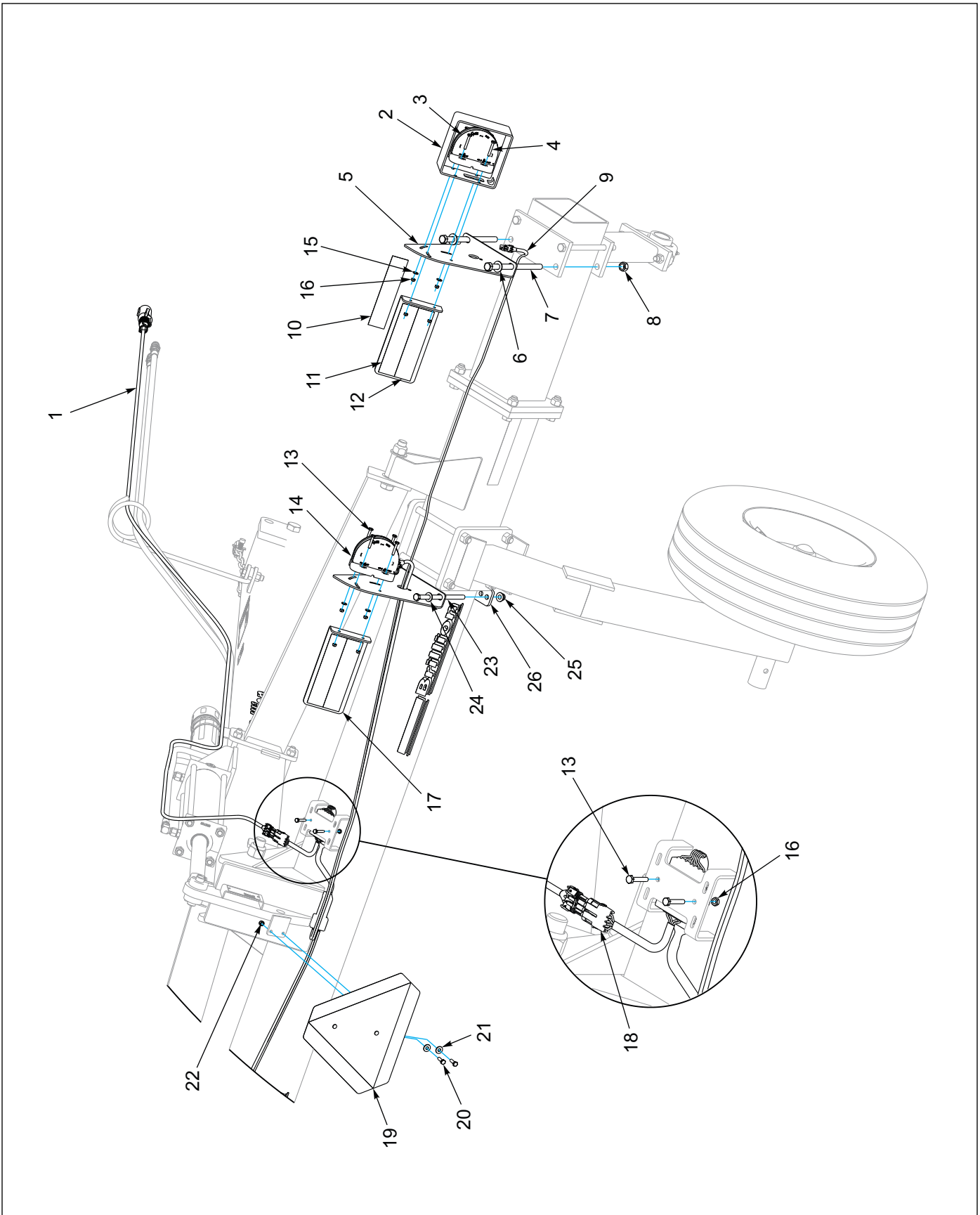

Figure 1-10: Electrical

## Electrical

ITEM	PART NUMBER	DESCRIPTION	QTY.
1	178516	HARNESS, 7 PIN/4 PIN WP, 20'	1
2	164700	TUBE LIGHT SHIELD	2
3	174436	LAMP, AG AMBER SINGLE LED	2
4	1-654-010047-09	SCREW, HX CP, 1/4-20UNC X 1-3/4 G5	8
5	188040	BRACKET, LIGHTMOUNT	4
6	1-861-010032-18	WASHER, FLAT 5/8 N ZP/CD	4
7	1-654-010059-24	SCREW HX CP 5/8-11UNC X 9 1/2	8
8	1-512-010005-13	NUT,HEX SLFLKG GRB 5/8-11	12
9	178513	HARNESS, LAMP 66 X 138	1
10	528934	REFLECTOR - YELLOW	2
11	528938	STRIPE, ORANGE	4
12	528933	REFLECTOR - RED	4
13	1-654-010047-08	SCREW,HX CP, 1/4-20UNC X 1-1/2 G5	10
14	174435	LAMP, AG RED SINGLE LED	2
15	1-861-010032-06	WASHER, FLAT 1/4 N ZP/CD	8
16	1-512-010005-01	NUT,HEX SLFLKG GRB 1/4-20	18
17	164697	PLATE CONSPICUITY DECAL MOUNT	4
18	174437	MODULE, AG FLASHER CONTROL	1
19	2P151	SMV W/BRACKET	1
20	1-654-010049-05	SCREW HX CP 5/16-18UNC X 1 GR5	2
21	1-861-010032-09	WASHER, FLAT 5/16 W ZP/CD	2
22	104032	NUT,HX SLF-LKG W/MYL 5/16-18	2
23	1-654-010055-22	HHCS, 1/2-13 X 8-1/2	4
24	1-861-010032-14	WASHER, FLAT 1/2 SAE	4
25	2P253	NUT, FLANGE LOCK 1/2-13	4
26	4K970	STRAP	2
27	105-0228	TY-WRAP ( <b>NOT SHOWN</b> )	12
28	7K678	CABLE TIE ( <b>NOT SHOWN</b> )	12

## ILLUSTRATED PARTS LIST

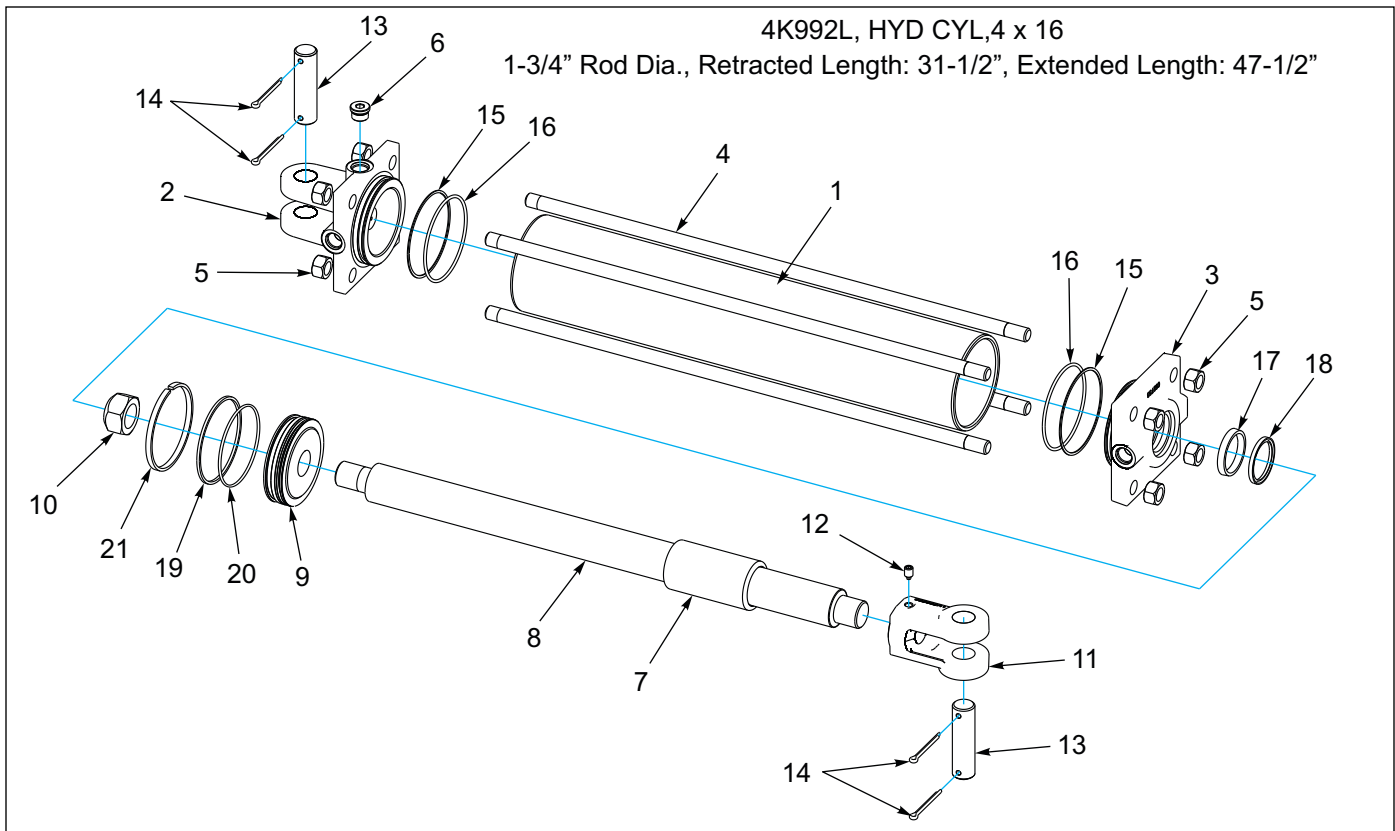

Figure 1-11: Hydraulic Cylinder, 4 x 16

### Hydraulic Cylinder, 4 x 16

ITEM	PART NUMBER	DESCRIPTION	QTY.
	4K992	CYLINDER, HYD 4X16 (LION)	
1	NSS	TUBE	1
2	NSS	CLEVIS CAP	1
3	NSS	ROD CAP	1
4	NSS	TIE ROD	4
5	NSS	NUT, HEX 5/8-18, ZP	8
6	NSS	PLUG, SOCKET HEAD 3/4-16	1
7	NSS	STOP TUBE	1
8	NSS	ROD	1
9	NSS	PISTON	1
10	8J852	NUT, LOCK 1-1/8-12,GRB, ZP	1
11	2P741	ROD CLEVIS	1
12	1P443	SET SCREW, 3/8-16 X 1/2 NYLON TIP	1
13	5J650	PIN, 1.0 X 3.625	2
14	110-4224	PIN,COTTER 3/16 X 2IN LG	4
15	NSS	SEAL,BU#240 19PI-240	2
16	NSS	O-RING,240 (3.75 X 4.0) DURO 90	2
17	NSS	SEAL,HALLITE 605 ROD 1.75D	1
18	NSS	SEAL,NOK-AR2573-EO 1.75BO	1
19	NSS	SEAL,PTFE PISTON RING 4DIA	1
20	NSS	O-RING,153 (3.5 X 3.688) DUR	1
21	NSS	WEAR RING, 4.00-3.75-.25-GFN	1
22	1P745	LION CYLINDER SEAL KIT (4.0") (INCLUDES ITEMS 15-21)	REF



# ILLUSTRATED PARTS LIST

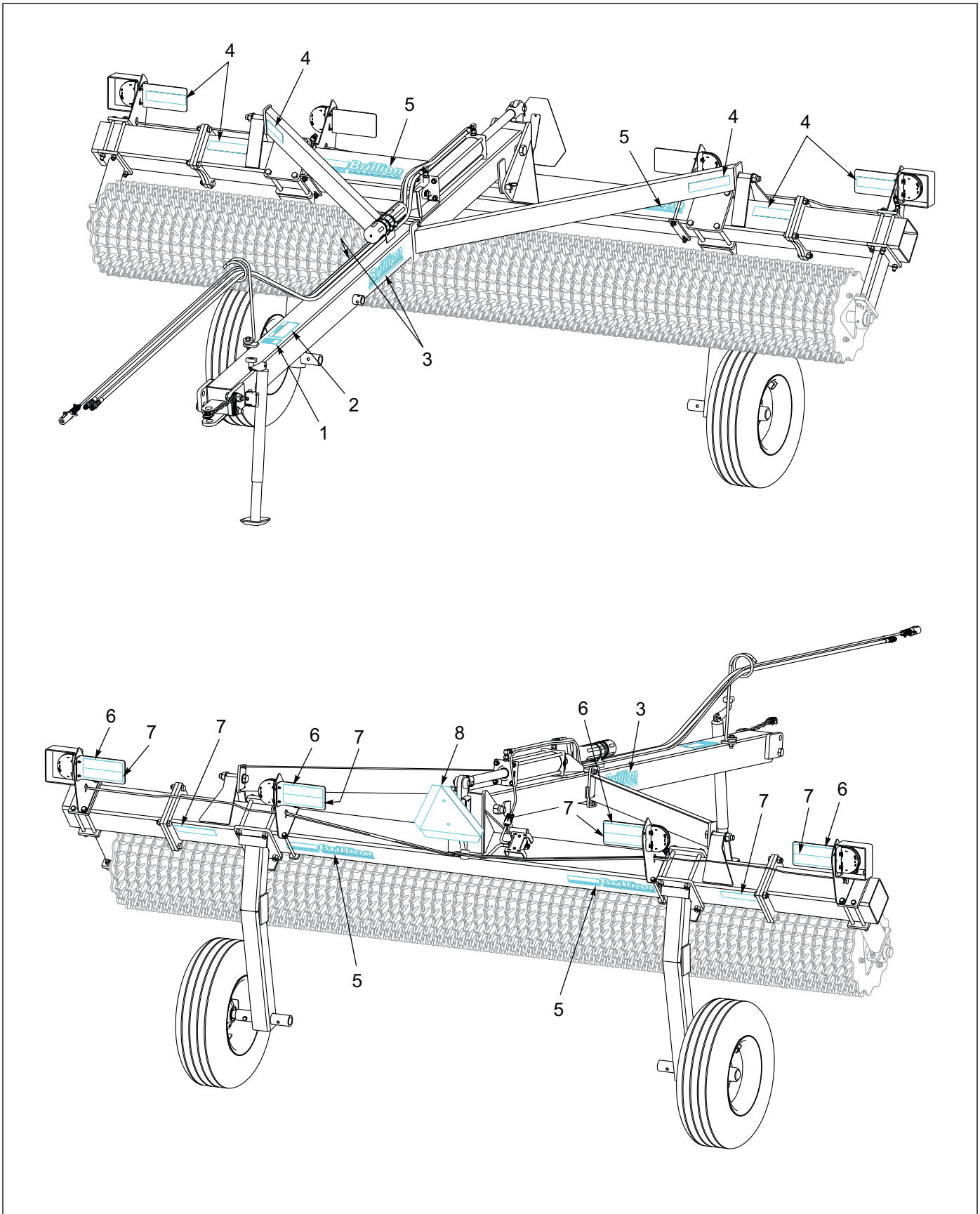

Figure 1-12: Decals

**Decals**

ITEM	PART NUMBER	DESCRIPTION	QTY.
1	3K706	DECAL-WARNING HYDRAULIC LEAKS	1
2	8J310	DECAL - CAUTION	1
3	4K103	DECAL-BRILLION (3 3/4 X 16 3/4)	2
4	528934	REFLECTOR - YELLOW	6
5	4K036	DECAL-BRILLION (2 3/4 X 20)	4
6	528938	STRIPE, ORANGE	4
7	528933	REFLECTOR - RED	4
8	2P151	SMV W/BRACKET	1





## Numerical Index

### Numerics

101385	1-8	1D273	1-4
102271	1-8	1J390	1-4
104436	1-3	1J463	1-4
105-0093	1-8	1K557	1-8
105-0228	1-15	1P827	1-11
1-076-010008	1-4	1P828	1-11
110-0344	1-4	202702-8-8S	1-12
1-116-010019	1-8	2071-8-8S	1-12
1-298-010001-1	1-4, 1-8	2P151	1-19
141433	1-8	2P253	1-15
141828	1-12	3/4-16HSN	1-4
150273	1-12	3J608	1-8
1-512-010005-05	1-8	3J880	1-8
1-512-010005-09	1-3, 1-6	3K706	1-19
1-512-010005-13	1-8, 1-10, 1-11	4J548	1-8
1-512-010005-15	1-3	4K036	1-19
1-512-010005-19	1-8	4K392	1-10, 1-11
1-557-010327	1-8	4K607	1-12
159569	1-12	4K941	1-3
1-654-010051-05	1-8	4K965	1-3
1-654-010055-09	1-3, 1-6	4K970	1-15
1-654-010055-22	1-15	4K971	1-8
1-654-010059-05	1-8	4K988	1-10, 1-11
1-654-010059-21	1-8	4K989	1-3
1-654-010061-07	1-3	4K990	1-3
1-861-010032-14	1-15	4K991	1-3
1-861-010032-18	1-8	4K992	1-8, 1-12
1-861-010032-24	1-8	4K995	1-8
		528933	1-19

## NUMERICAL INDEX

---

528934	1-19
528938	1-19
5C100	1-3, 1-6
5C479	1-4
5C480	1-4
5C912	1-4
5K031	1-10
5K032	1-10
5K033	1-11
5K034	1-11
5K035	1-11
5K066	1-10
5K067	1-10
5K068	1-11
5K069	1-11
5K070	1-11
5K168	1-6
5K195	1-3
6D333	1-8
6D865	1-8
6J189	1-5
6K309	1-3
6K310	1-11
6K313	1-11
6K458	1-8
6K924	1-3, 1-5, 1-6
7K664	1-8
7K678	1-15
8J791	1-5
8J792	1-5
9D227	1-8
9J015	1-8
9J330	1-4
9J331	1-3, 1-4, 1-6

# Chapter 3

## Glossary

---

For clarity this glossary of industry standard abbreviations and their definitions are provided.

For additional information, See "Instructions for Ordering Parts" on page 1-1.

### A

---

**ASSY** ..... Assembly  
**ASM** ..... Assembly

### B

---

**BHSC** ..... Button Head Socket Cap  
**BLK** ..... Black  
**BRG** ..... Bearing

### C

---

**CB** ..... Carriage Bolt  
**CONN** ..... Connector  
**CRG** ..... Carriage  
**CVR** ..... Cover  
**CYL** ..... Cylinder

### D

---

**DBL** ..... Double  
**DIA** ..... Diameter

### E

---

**ENCLSD** ..... Enclosed

### F

---

**FHCS** ..... Flanged Head Cap Screw

**FHHCS** ..... Flanged Hex Head Cap Screw  
**FL OR FLG** ..... Flange  
**FLT** ..... Flat  
**FTG** ..... Fitting

### G

---

**GA** ..... Gauge  
**Gr** ..... Grade

### H

---

**HHCS** ..... Hex Head Cap Screw  
**HD** ..... Head  
**HLCL** ..... Helical  
**HCSKT** ..... Hex Socket  
**HYD** ..... Hydraulic

### I

---

**ID** ..... Inside Diameter

### L

---

**LH** ..... Lefthand  
**LKG OR LOCK** ..... Locking  
**LWR** ..... Lower

### M

---

**MANF** ..... Manifold  
**MNT** ..... Mount

### N

---

**NRW** ..... Narrow

## GLOSSARY

---

NSS ..... Not Serviced Separately

### O

---

OD ..... Outside Diameter

ORFS OR ORS ..... O-Ring Seal

ORP OR ORB ..... O-Ring Boss

### R

---

RH ..... Righthand

RND ..... Round

### S

---

SER ..... Series

SHCS ..... Socket Head Cap Screw

SKT ..... Socket

SLFLKG ..... Selflocking

SOC ..... Socket

SPR ..... Spring

SQ ..... Square

SRTD ..... Serrated

SSCR ..... Setscrew

SST ..... Stainless Steel

STD ..... Standard

### U

---

UPR ..... Upper

### W

---

WHL ..... Wheel

WLD OR WLDMT ..... Weldment

### Z

---

ZP ..... Zinc Plated

---

**Document Control Revision Log:**

Date	Revision	Improvement(s) Description and Comments	Team Member
02/2015	0215	Improved Drawings, Updated Parts Listings	WML

---



**Intertek**

Equipment from Landoll Company, LLC is built to exacting standards ensured by ISO 9001 registration at all Landoll manufacturing facilities.

# **Floating Ring Pulverizer PFT 10' through 18' Models Parts Manual**

Re-Order Part Number 5K088rev0215

**LANDOLL COMPANY, LLC**

1900 North Street

Marysville, Kansas 66508

(785) 562-5381

**800-428-5655 ~ WWW.LANDOLL.COM**



Copyright 2020. Landoll Company, LLC

“All rights reserved, including the right to reproduce this material or portions thereof in any form.”