

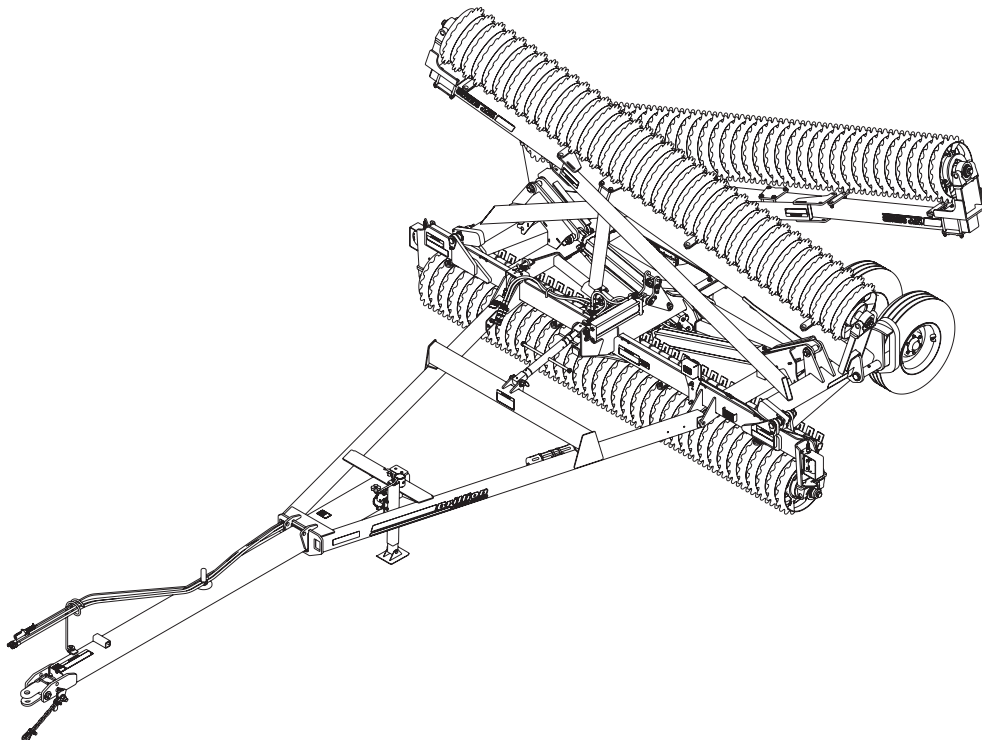

Wing Float Pulverizer
Models: WFPD23-37, WFPO23-37 & WFPC23-37
With Scrapers: WFPDS23-37
Operator's Manual



LANDOLL COMPANY, LLC

1900 North Street

Marysville, Kansas 66508

(785) 562-5381

800-428-5655 ~ WWW.LANDOLL.COM

Manuals for Wing Float Pulverizers 23-37

Manual Number	Manual Type
F-1108	Operator's Manual
F-1109	Parts Manual

Table of Contents

1 Safety Information

Introduction	1-1
Description of Unit	1-1
Owner Assistance	1-1
Warranty Registration	1-1
Safety	1-2
Understanding Safety Statements	1-2
Transporting Safety	1-2
Safety Instructions for Towing Vehicles	1-3
Attaching, Detaching and Storage	1-3
Maintenance Safety	1-3
Protective Equipment	1-3
Tire Safety	1-3
Chemical Safety	1-3
Prepare for Emergencies	1-3
High Pressure Fluid Safety	1-3
Safety Chain	1-4
Decals	1-5

2 Assembly

Transport Axle Installation	2-2
Transport Axle Linkage Installation	2-4
Tire and Wheel Installation	2-6
Center Frame Roller Assembly Installation	2-7
Drawbar Installation	2-10
Drawbar Jack, Hose Support and Manual Storage Canister Installation	2-11
Wing Fold Cylinder Installation	2-13
Hydraulic Installation	2-14
Purging the Hydraulic System	2-18
Wing Installation	2-20
Wing Frame Roller Assembly Installation	2-22
Wing Rest Installation, WFP 23-29	2-24
Wing Rest Installation, WFP 31-37	2-25
Warning Lamp Installation	2-26
SMV Sign Installation	2-26
Center Roller Scrapers - Optional	2-28
Wing Roller Scrapers - Optional	2-29
Acre Meter Installation - Optional	2-30
Float Lock Kit - Optional	2-32
Hydraulic Top Link Kit – Optional	2-33

3 Operation

Tractor Preparation	3-2
Pulverizer Preparation	3-2
Attaching to the Tractor	3-2
Hitch Lock	3-3
Telescoping Drawbar	3-4
Hydraulic System	3-5
General Operation	3-6
Transport Lock	3-7
Scraper Adjustment	3-8
Electronic Acre Meter Kit	3-9
Transporting on a Trailer	3-11
Transport	3-12

4 Maintenance

General Torque Specifications	4-1
Hydraulic Fitting Torque Specifications	4-2
Fasteners	4-2
Tires	4-3
Lubrication Maintenance	4-4
Hydraulic System	4-5
Purging Hydraulic System	4-6
Roller Bearing Maintenance	4-6
Roller Axle Assembly	4-8
Clamp Tightening	4-8
LED Warning Lamps	4-11
Acre Meter Troubleshooting	4-12
Storage	4-12
Maintenance Chart	4-13
Troubleshooting	4-14

5 General Reference and Specifications

Safety Information

Introduction

The implement described in this manual has been designed with care and built by skilled workers using quality materials and processes. Proper assembly and maintenance will provide you with satisfactory use for seasons to come.

DANGER

Read this entire manual before attempting to assemble, adjust or operate this implement. Failure to comply with this warning can result in personal injury or death, damage to the implement or its components and inferior operation.

Description of Unit

The Brillion Wing Float Pulverizer is designed with a rigid or telescoping drawbar (Size Dependent) making it versatile to use directly behind a tractor or a companion tool in both pre-plant and post-plant situations. By its patented design, the wings and the center section operate independently during field operation. The wings are capable of floating in two planes vertically and horizontally without altering the position of the center section. The Wing Float Pulverizer uses a single hydraulic circuit that lifts and folds the machine. Trunnions Bearings mount the 8" Rollers Axles with a choice of 20" Notched Ductile, 20" Optimizer and 20" Crowfoot Wheels.

Using this Manual

This manual will familiarize you with safety, assembly, operation, adjustment, and maintenance. Read this manual and follow the recommendations to help ensure safe and efficient operation.

- The information in this manual is current at time of printing. Some parts may have changed to assure top performance.
- Location reference: Right and Left designations in this manual are determined by facing the direction the implement will travel during field operation, unless otherwise stated.

Owner Assistance

If customer service or repairs are needed, contact your Brillion dealer. They have trained personnel, parts and service equipment specially designed for Brillion products. Your implement's parts should only be replaced with Brillion parts. If items covered in this manual are not understood, contact your local Brillion dealer.

Warranty Registration

Brillion Farm Equipment, by Landoll, shall have no warranty obligation unless each product is registered within 10 days of retail purchase, using the Landoll Company, LLC Ag Products on-line registration process. Please refer to the Ag Products Policy and Procedures Manual, accessible at www.landoll.com for step by step instructions regarding product registration.

Enter your product information below for quick reference.

MODEL NUMBER

SERIAL NUMBER

DATE OF PURCHASE

Refer to the ID plate as shown. **See Figure 1-1.**

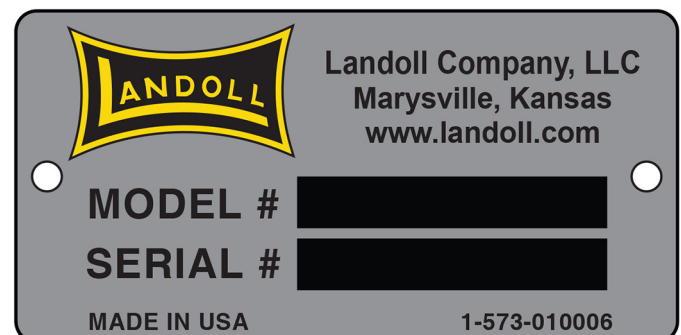

Figure 1-1: ID Plate

Safety

NOTE

Investigation has shown that nearly 1/3 of all farm accidents are caused by careless use of machinery. Insist that all people working with you or for you abide by all safety instructions.

Understanding Safety Statements

You will find various types of safety information on the following pages and on the implement decals (signs) attached to the implement. This section explains their meaning.

NOTICE

Special notice - read and thoroughly understand.



CAUTION

Proceed with caution. Failure to heed caution may cause injury to person or damage product.



WARNING

Proceed with caution. Failure to heed warning will cause injury to person or damage product.



DANGER

Proceed with extreme caution. Failure to heed notice will cause injury or death to person and/or damage product.

NOTE

You should read and understand the information contained in this manual and on this implement decals before you attempt to operate or maintain this equipment.

- Examine safety decals and be sure you have the correct safety decals for the implement. **See Figure 1-3.**
- Order replacement decals through your Brillion dealer.
- Keep these signs clean so they can be observed readily. It is important to keep these decals cleaned more frequently than the implement. Wash with soap and water or a cleaning solution as required.
- Replace decals that become damaged or lost. Also, be sure that any new implement components installed during repair include decals which are assigned to them by the manufacturer.

- When applying decals to the implement, be sure to clean the surface to remove any dirt or residue. Where possible, sign placement should protect the sign from abrasion, damage, or obstruction from mud, dirt, oil etc.



DANGER

- **Do not allow anyone to ride on the tractor or implement. Riders could be struck by foreign objects or thrown from the implement.**
- **Never allow children to operate equipment.**
- **Keep bystanders away from implement during operation.**

Transporting Safety

IMPORTANT

It is the responsibility of the owner/operator to comply with all state and local laws.

- When transporting the implement on a road or highway, use adequate warning symbols, reflectors, lights and slow moving vehicle sign as required. Slow moving tractors and towed implements can create a hazard when driven on public roads. They are difficult to see, especially at night.
- Do not tow an implement that, when fully loaded, weighs more than 1.5 times the weight of the towing vehicle.
- Carry reflectors or flags to mark the tractor and implement in case of breakdown on the road.
- Do not transport at speeds over 20 MPH under good conditions. Never travel at a speed which does not allow adequate control of steering and stopping. Reduce speed if towed load is not equipped with brakes
- Avoid sudden stops or turns because the weight of the implement may cause the operator to lose control of the tractor. Use a tractor heavier than the implement.
- Use caution when towing behind articulated steering tractors; fast or sharp turns may cause the implement to shift sideways.
- Keep clear of overhead power lines and other obstructions when transporting. Know the transport height and width of your implement. **See Figures 5-1 and 5-2.**

Safety Instructions for Towing Vehicles

The maximum travel speed is the lesser of

- The limit of the road conditions;
- The maximum specified ground speed;
 - for towing operations as indicated in this manual or SIS;
 - of the towed vehicle as indicated in its operator's manual, SIS, or information sign;
- The maximum ground speed of the towed equipment combination shall be limited to the lowest specified ground speed of any of the towed machines. This speed is the ground speed limitation.

EXAMPLE: If the tractor is capable of 25 mph, the first implement has a SIS for 19 mph, and the last implement's operator's manual states its specified ground speed is 15 mph, the towed equipment combination ground speed limitation is 15 mph.

Attaching, Detaching and Storage

- Do not stand between the tractor and implement when attaching or detaching implement unless both are blocked from moving.
- Before applying pressure to the hydraulic system, be sure all connections are tight and that hydraulic hoses are not damaged.
- Block implement so it will not roll when unhitched from the tractor.
- Relieve pressure in hydraulic circuit before uncoupling hydraulic hoses from tractor.

NOTE

To relieve hydraulic pressure: Depending on tractor hydraulic system, some can be relieved by actuating control lever after engine is stopped. If tractor has electric over hydraulic controls, it may be necessary to move the control lever to the float position. Refer to tractor's operator's manual.

Wear protective gloves and safety glasses or goggles when working with hydraulic systems.

Maintenance Safety

- Block the implement so it will not roll when working on or under it to prevent injury.
- Do not make adjustments or lubricate the machine while it is in motion.
- Make sure all moving parts have stopped.
- Understand the procedure before doing the work. Use proper tools and equipment.

Protective Equipment

- Wear protective clothing & equipment appropriate for the job. Avoid loose fitting clothing.
- Because prolonged exposure to loud noise can cause hearing impairment or hearing loss, wear suitable hearing protection, such as earmuffs or earplugs.

Tire Safety

Tire changing can be dangerous and should be performed by trained personnel using correct tools and equipment.

- When inflating tires, use a clip-on chuck and extension hose long enough to allow you to stand to one side, not in front of or over the tire assembly. Use a safety cage if available.
- When removing and installing wheels use wheel-handling equipment adequate for the weight involved.

Chemical Safety

Agricultural chemicals can be dangerous. Improper use can seriously injure persons, animals, plants, soil & property.

- Read chemical manufactures instructions and store or dispose of unused chemicals as specified. Handle chemicals with care & avoid inhaling smoke from any type of chemical fire.
- Store or dispose of unused chemicals as specified by the chemical manufacturer.

Prepare for Emergencies

- Keep a First Aid Kit and Fire Extinguisher handy.
- Keep emergency numbers for the doctor, ambulance, hospital and fire department near the phone.

High Pressure Fluid Safety

Escaping fluid under pressure can be nearly invisible and have enough force to penetrate the skin causing serious injury. Use a piece of cardboard, rather than hands, to search for suspected leaks.

Any fluid injected into the skin must be surgically removed within a few hours or gangrene may result.

Avoid the hazard by relieving pressure before disconnecting hydraulic lines.

NOTE

Relieve hydraulic pressure by shifting the control valve lever to float.

Wear protective gloves and safety glasses or goggles when working with hydraulic systems.

Safety Chain

Use the safety chain to help control drawn machinery should it separate from the tractor drawbar.

- Use a chain with a strength rating equal to or greater than the gross weight of towed machinery, which is 21,100 pounds minimum in accordance with ASAE S338.2 specifications. If two or more implements are pulled in tandem, a larger chain may be required. Chain capacity must be greater than the TOTAL weight of all towed implements.
- A second chain should be used between each implement.

- Attach the chain to the tractor drawbar support or specified anchor location. Allow only enough slack in the chain to permit turning. The distance from hitch pin to attachment point or intermediate support point should not exceed 9 inches. **See Figure 1-2.**
- Replace the chain if any links or end fittings are broken, stretched or damaged.
- Do not use a safety chain for towing.

See Page 3-3. for Hitch Lock functionality.

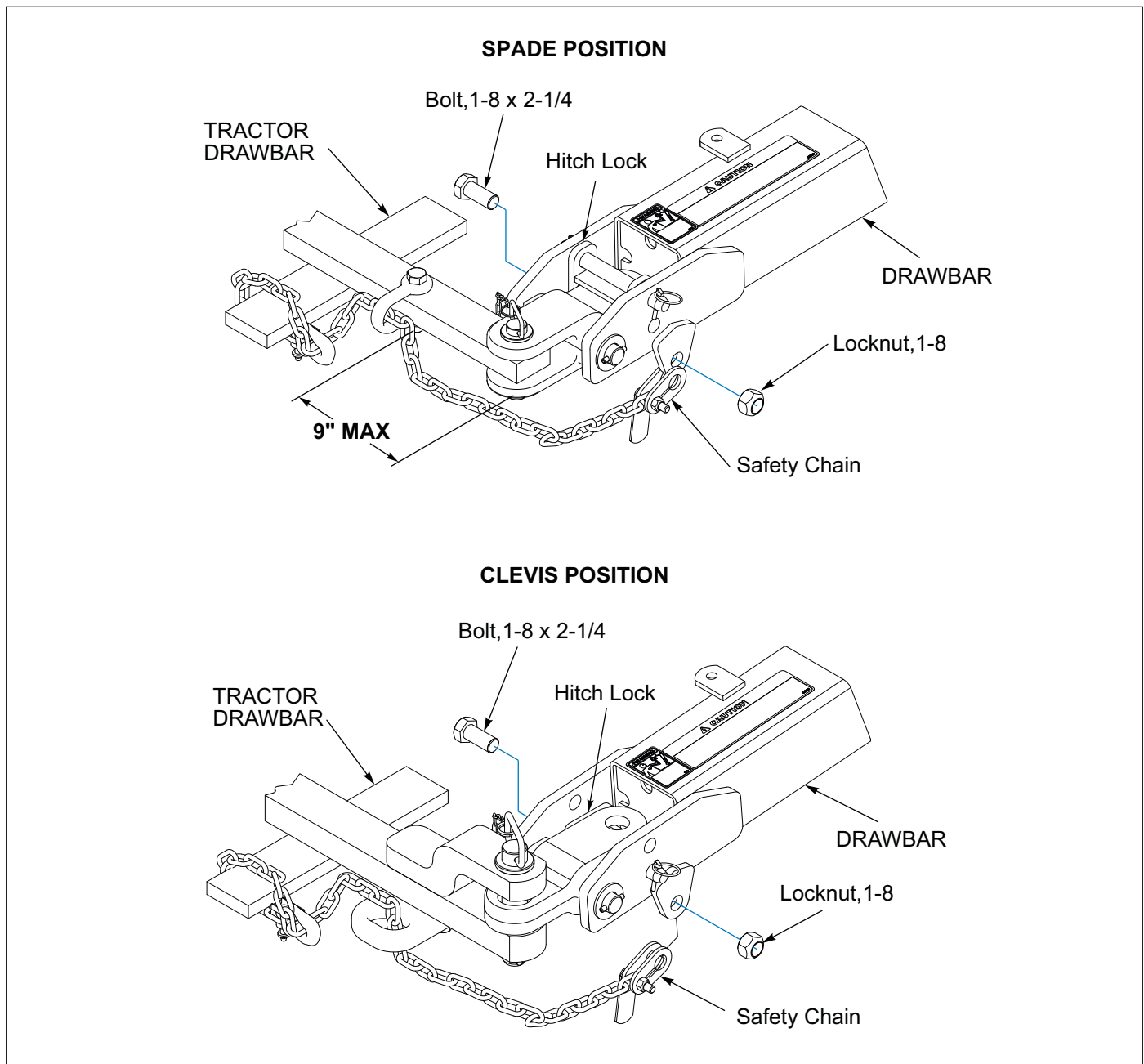
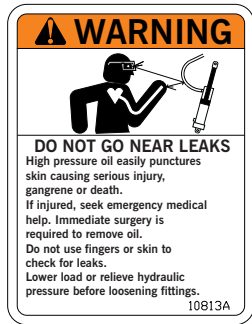
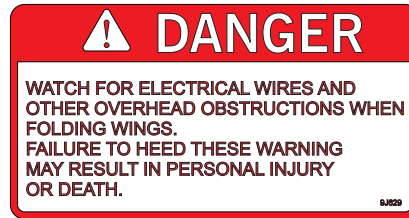

Figure 1-2: Safety Chain

Decals



ITEM 1
3K706



ITEM 2
9J629

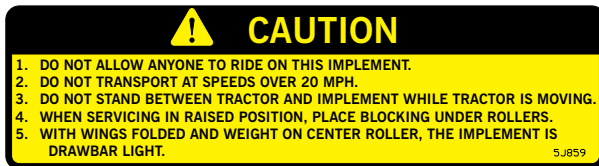

ITEM 3
5J859



ITEM 4
170505



ITEM 5
3J678



ITEM 6
3J675



ITEM 7
528933



ITEM 8
528938



ITEM 9
528934



ITEM 10
170510



ITEM 11
170509



ITEM 12
2P808

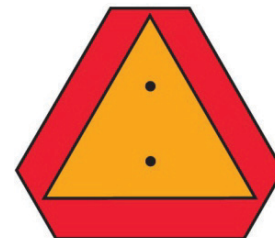

ITEM 13
2P151

Figure 1-3: Decals

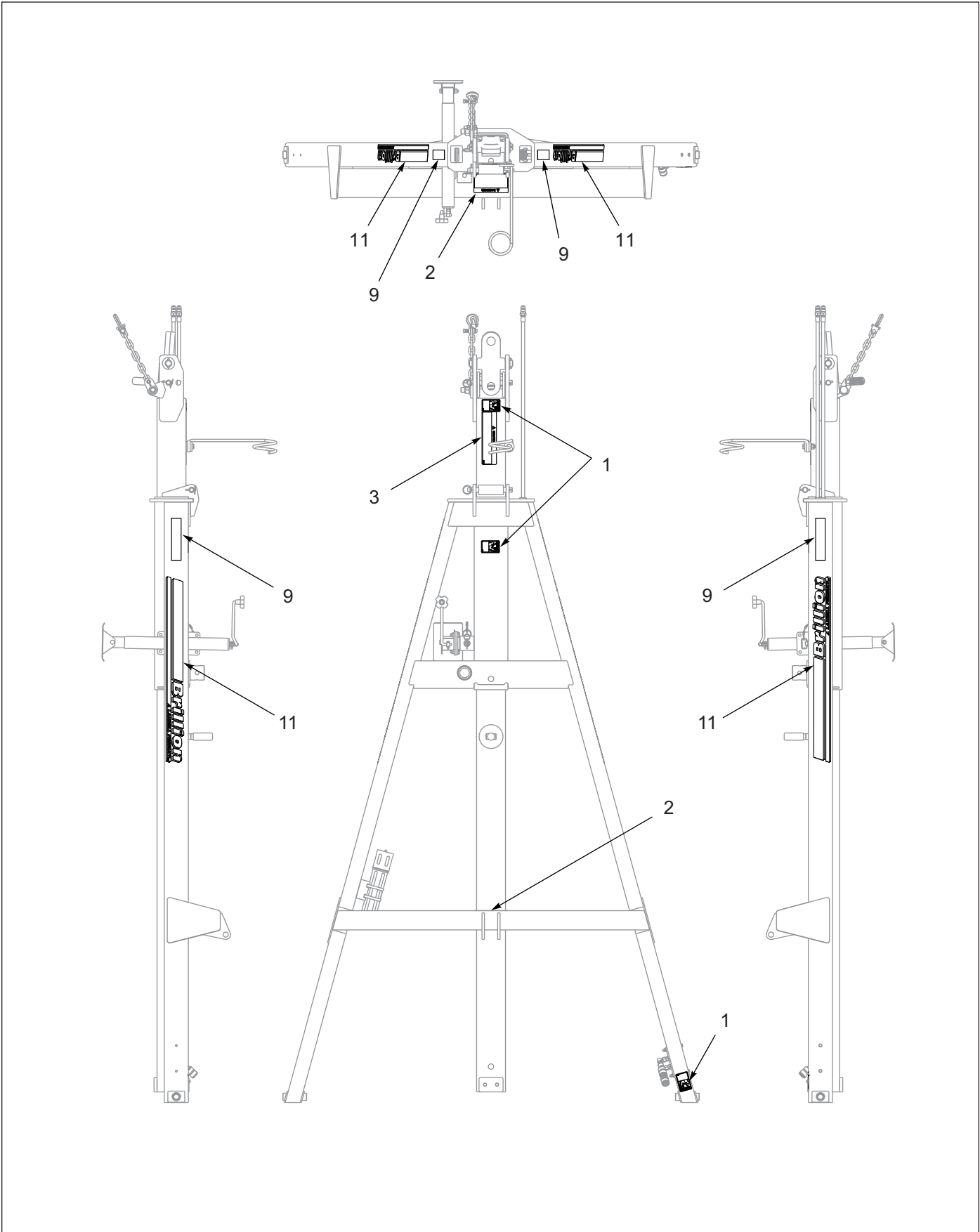
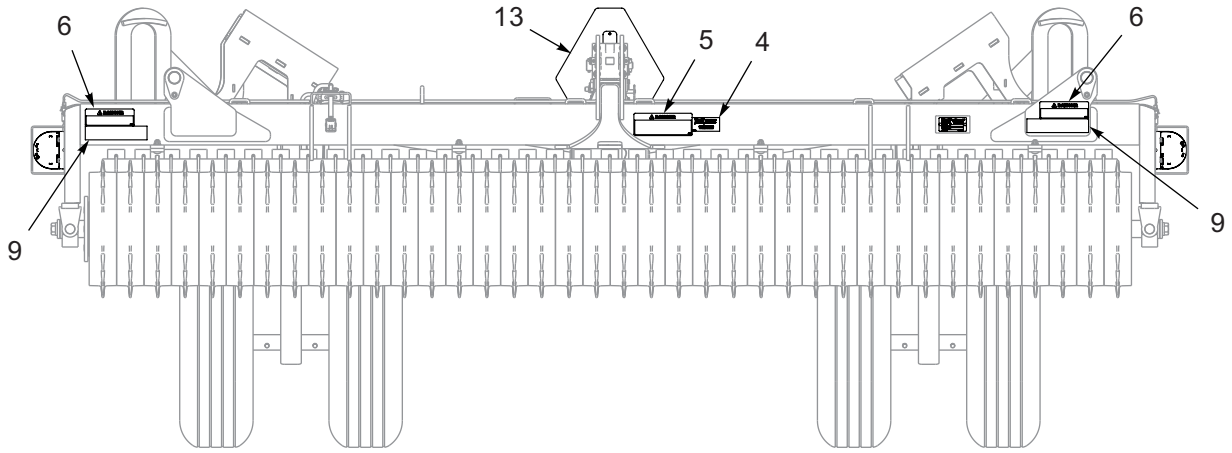
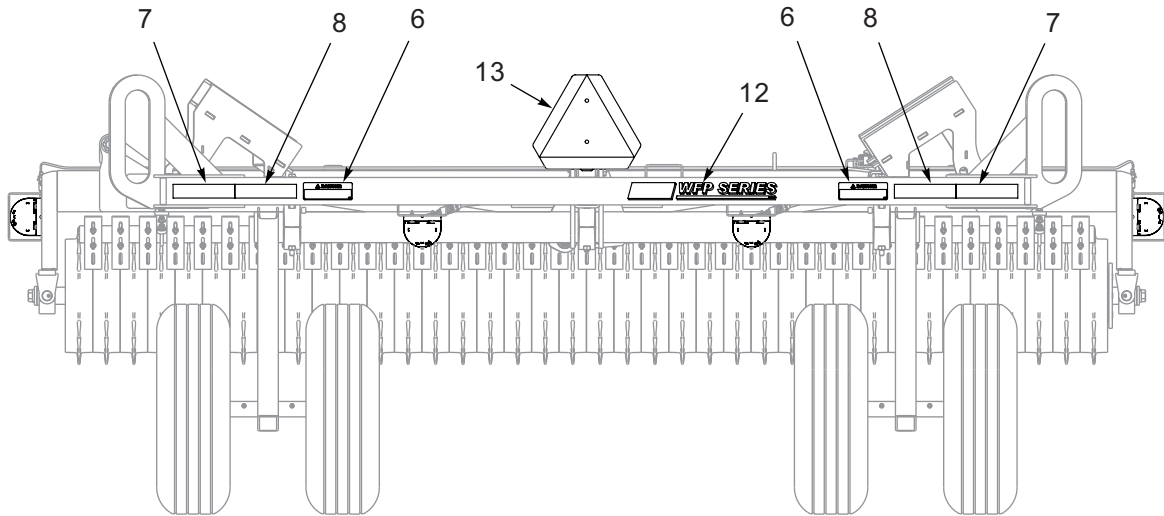

Figure 1-4: Decal Placement (1 of 4)



Center Frame Front View



Center Frame Back View

Figure 1-5: Decal Placement (2 of 4)

Wing - Left Hand

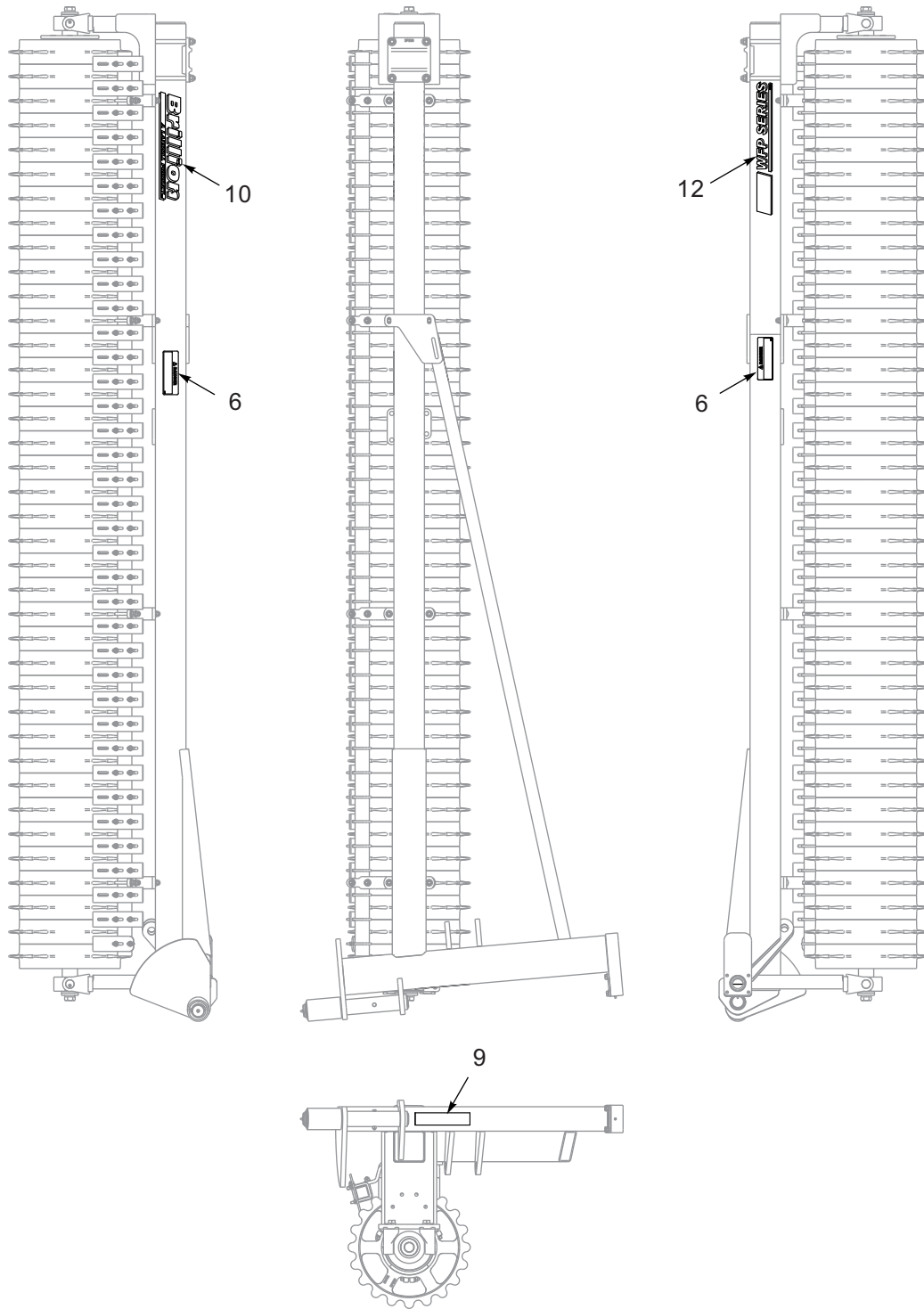

Figure 1-6: Decal Placement (2 of 4)

Wing - Right Hand

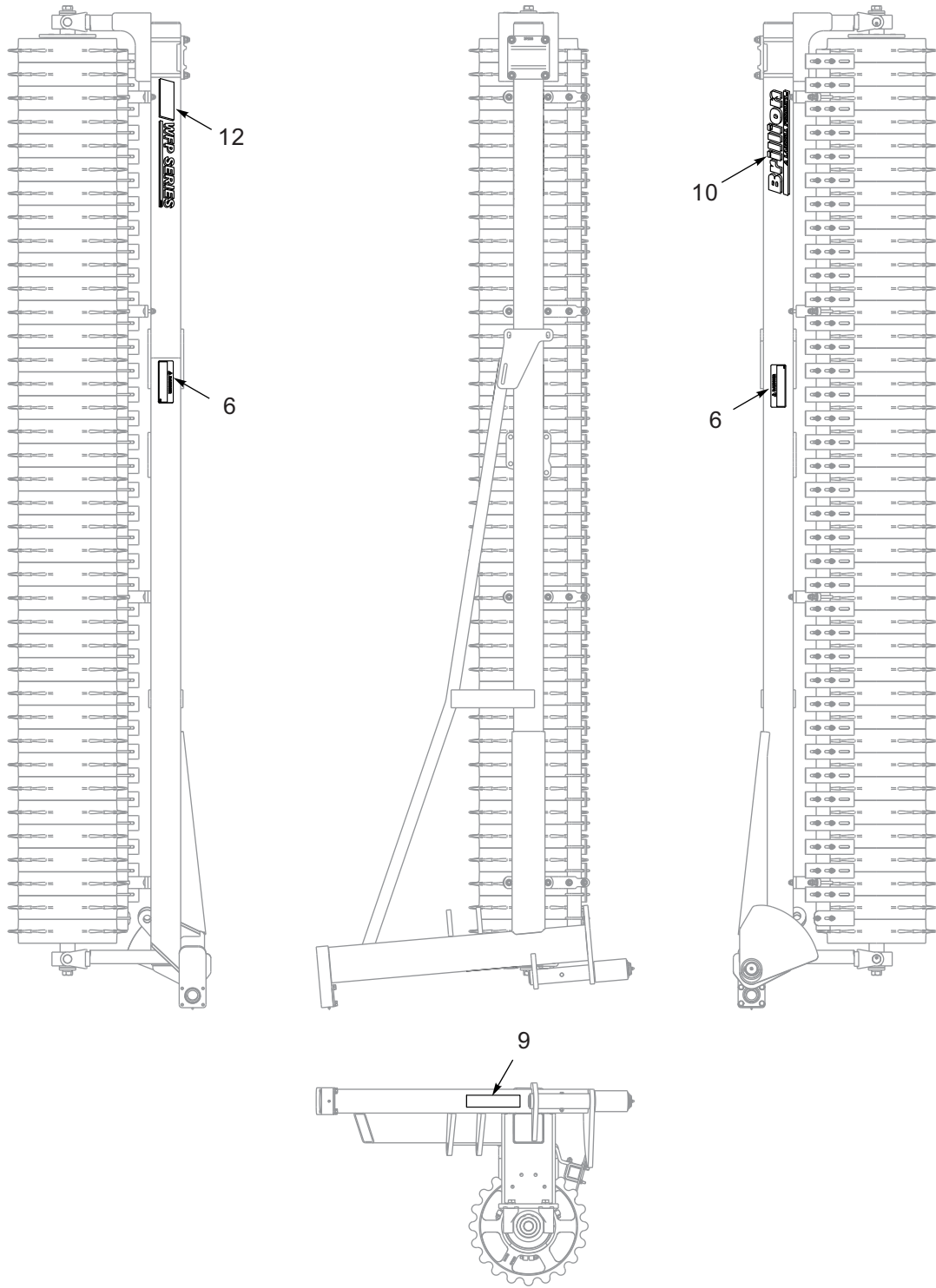

Figure 1-7: Decal Placement (3 of 4)

**CAUTION**

Do not work on or under this machine unless securely blocked and supported by a hoist or tractor or by other sufficient means.

**WARNING**

Do not attempt to lift heavy parts (such as the Frame, Rockshaft, and Pull Hitch) manually. Use a hoist or a fork lift to move these parts into position.

NOTE

Refer to the repair parts manual F-1109 for identification of parts and for the approximate relationship of the parts in assembly.

To ensure alignment of assemblies, leave the nuts loose until completion of final assembly. Use lock washers or flat washers as specified. Spread all cotter pins.

After completion of final assembly, tighten all nuts evenly to prevent misalignment, distortion or binding. Tighten all screws and nuts to the recommended torques.

IMPORTANT

- If pre-assembled parts or fasteners are temporarily removed, remember where they go. It is best to keep parts separated.
- Check that all working parts move freely, bolts are tight and cotter pins spread.
- Refer to the Torque Table for proper torque values. Note the different torque requirements for Bolts with Locknuts. **See Page 4-1.**

“Left” and “Right” refer to directions seen as if standing behind the machine and facing in the direction of forward travel.

Transport Axle Installation

NOTE

The Bearing Inserts are maintenance free and require no grease.

1. Select a smooth, level area that can be reached by a hoist or lift truck.
2. Place the Center Frame on supports, approximately 36 inches high and rated for 2,000 lbs. or higher.
3. Place a Bearing Insert into each Bearing half and attach Transport Axle to Center Frame, using 5/8-11 x 11 1/2" Bolts, Flat Washers, and Locknuts.

4. Install the base end of the 4 X 16 Hydraulic Cylinder using one of the pins provided with the Cylinder. The rod end of the Cylinder will be attached to the Lift Linkage at the same time as the Transport Axle Linkage. **See Figure 2-2.**
5. Tighten all hardware to the recommended torques. **See Page 4-1.**

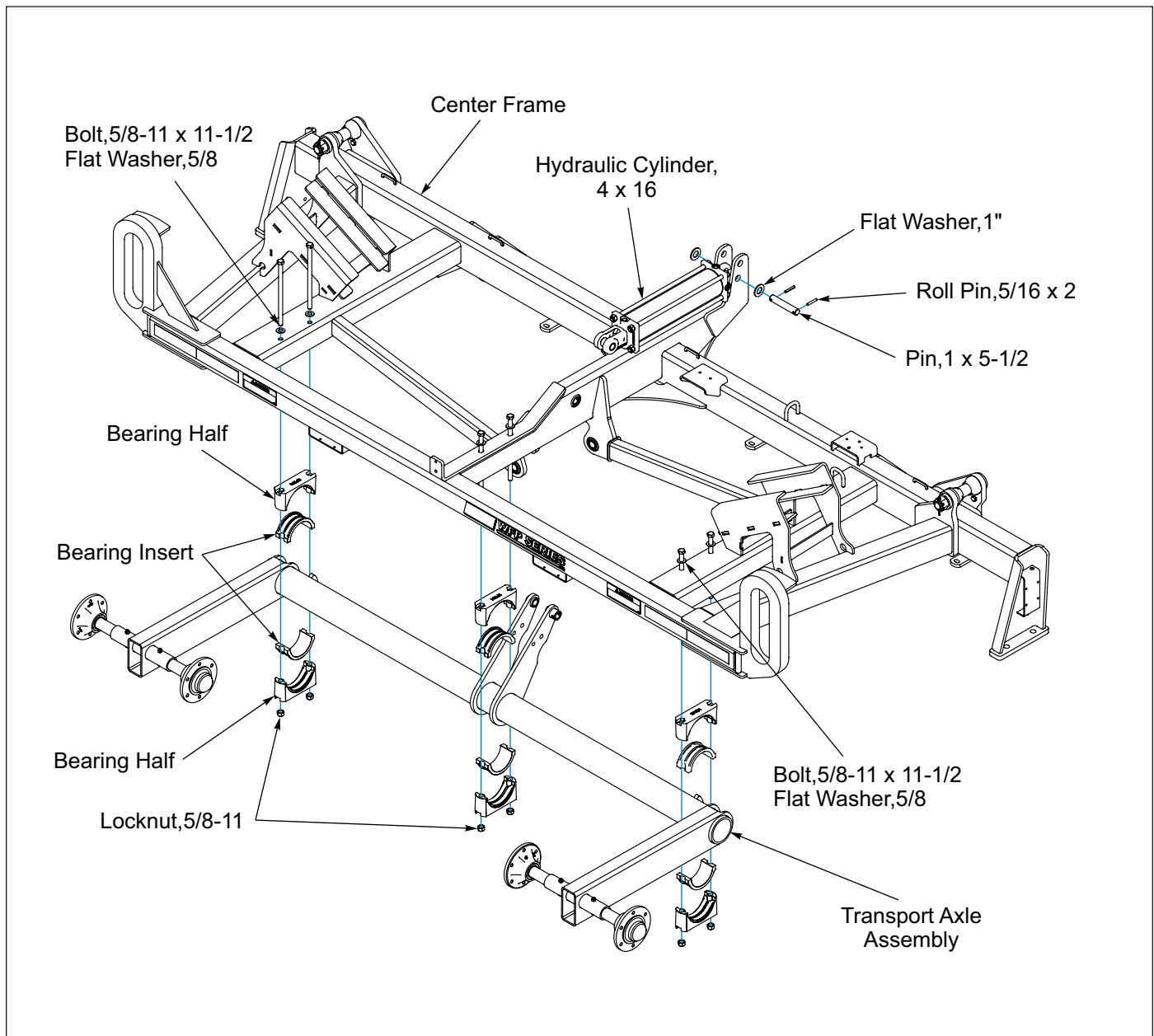

Figure 2-1: Transport Axle Installation

Transport Axle Linkage Installation

NOTE

Linkage must be free to rotate after assembly

IMPORTANT

Clevis Pin Transport Lock must be removed when lowering machine.

1. Assemble the Toggle Link Weldment to the Transport Axle Assembly with 1 x 6-3/4 Pin. Secure with 3/8 x 2 Roll Pins. **See Figure 2-2.**
2. Place 1-1/16 x 3-1/2 Spacer between Transport Axle Assembly Lugs. Secure with 5/8-11 x 6 Bolt and Flange Locknut.
3. Place the Toggle Link w/Tap on the left side and the Toggle Link on the right side of the Frame Center Tube. Align the Toggle Links with the Frame Center Tube Hole with spring bushing and insert 1" Pin w/Keeper from left to right. Place 1" Flat Washer on the end of the Pin. Secure with 3/8 x 2 Roll Pin.
4. Place the 1-3/8 x 1-1/16 Spacer between the Hydraulic Cylinder Rod Clevis ears. Place a 1 x 2 x 1/4 Washer on each side of the Cylinder Rod Clevis. Align Toggle Links with Cylinder Clevis and insert 1" Pin W/Keeper from left to right. Place 1" Flat Washer on the end of the Pin. Secure with 3/8 x 2 Roll Pin.
5. Place a 1 x 2 x 1/4 Washer on each side of the Toggle Link Weldment. Align Toggle Links with the Toggle Link Weldment and insert 1" Pin w/Keeper from left to right. Place 1" Flat Washer on the end of the Pin. Secure with 3/8 x 2 Roll Pin.
6. To prevent 1" Pins w/Keeper from rotating, secure with 5/16-18 x 3/4 Bolts.
7. Insert 1/2 x 6 Clevis Pin into the Toggle Link, under the Toggle Link Weldment and through the Toggle Link w/Tap. Secure with Hair Pin Cotter. *Clevis Pin is the Transport Lock.*

TABLE OF CONTENTS

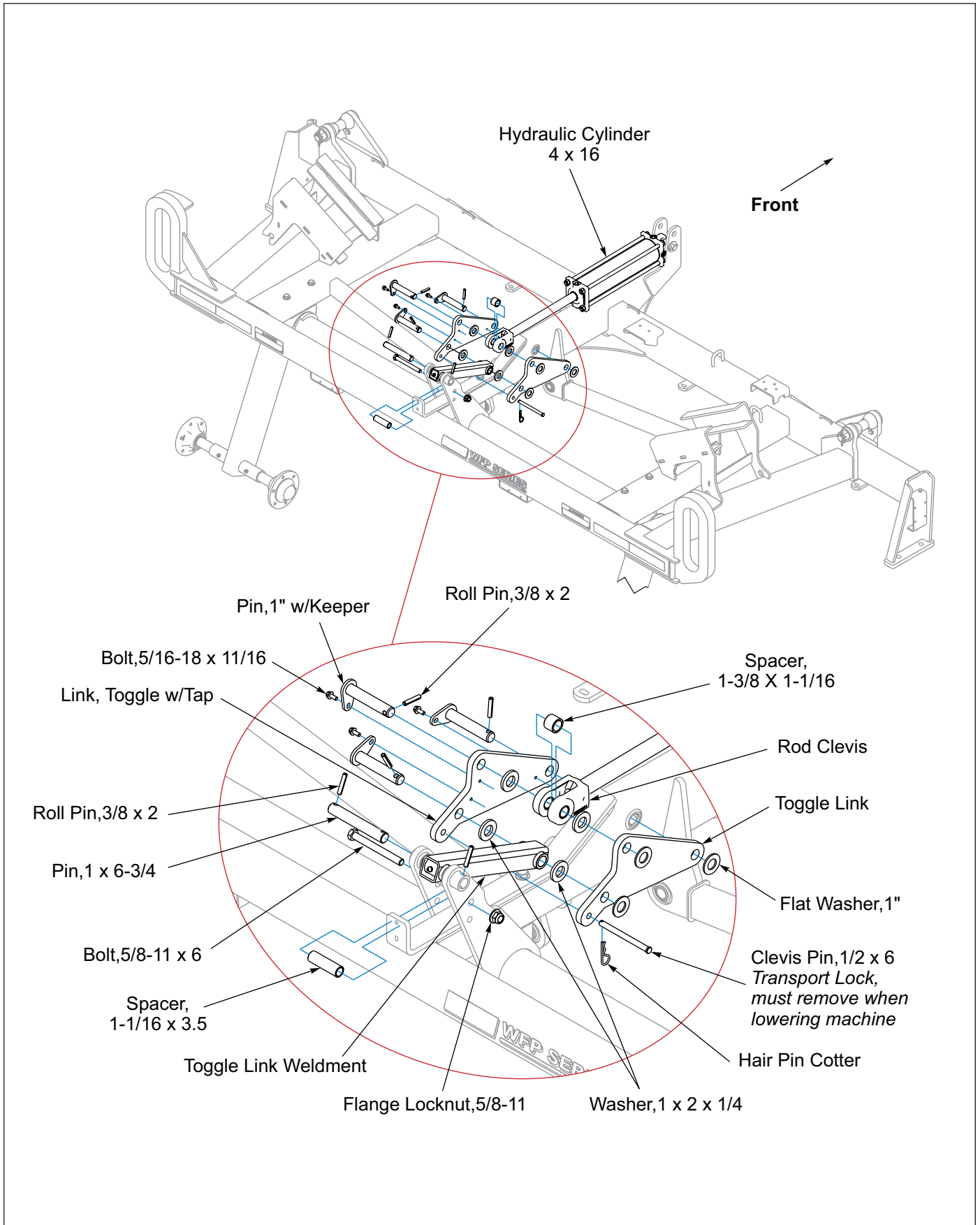

Figure 2-2: Transport Axle Linkage Installation

Tire and Wheel Installation



WARNING

Use a torque wrench to assure proper torque. Insufficient torque can cause stud breakage and damage the wheel pilots. Over torque can stress the Wheel Bolts.

NOTE

All tire/wheel assemblies are mounted with the valve stem facing outward from Hub and Spindle.

The Pulverizer uses 11L-15 12PLY rating tires and should be inflated to 52 PSI.

Install Tire and Wheel Assemblies onto Hub and Spindles with 1/2-20 x 1 Wheel Bolts. See Figure 2-4. Tighten 1/2-20 x 1 Wheel Bolts to 50 Ft-Lbs using the sequence in Figure 2-3. Tighten to a full torque of 85-90 Ft-Lbs.

Leave supports under the frame to support the machine in case of weight shift while adding components.

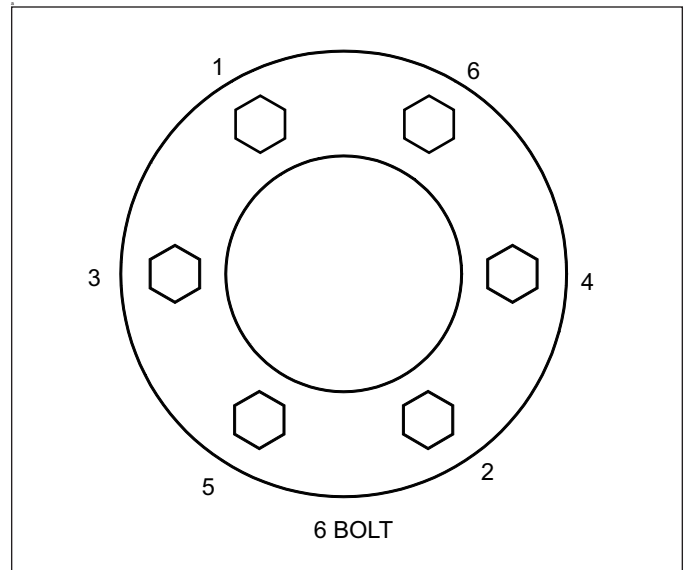

Figure 2-3: Stud Tightening Sequence

NOTE

Torque will drop after the first 10 hours of operation. Check the nuts for proper torque after this interval and re-tighten them.

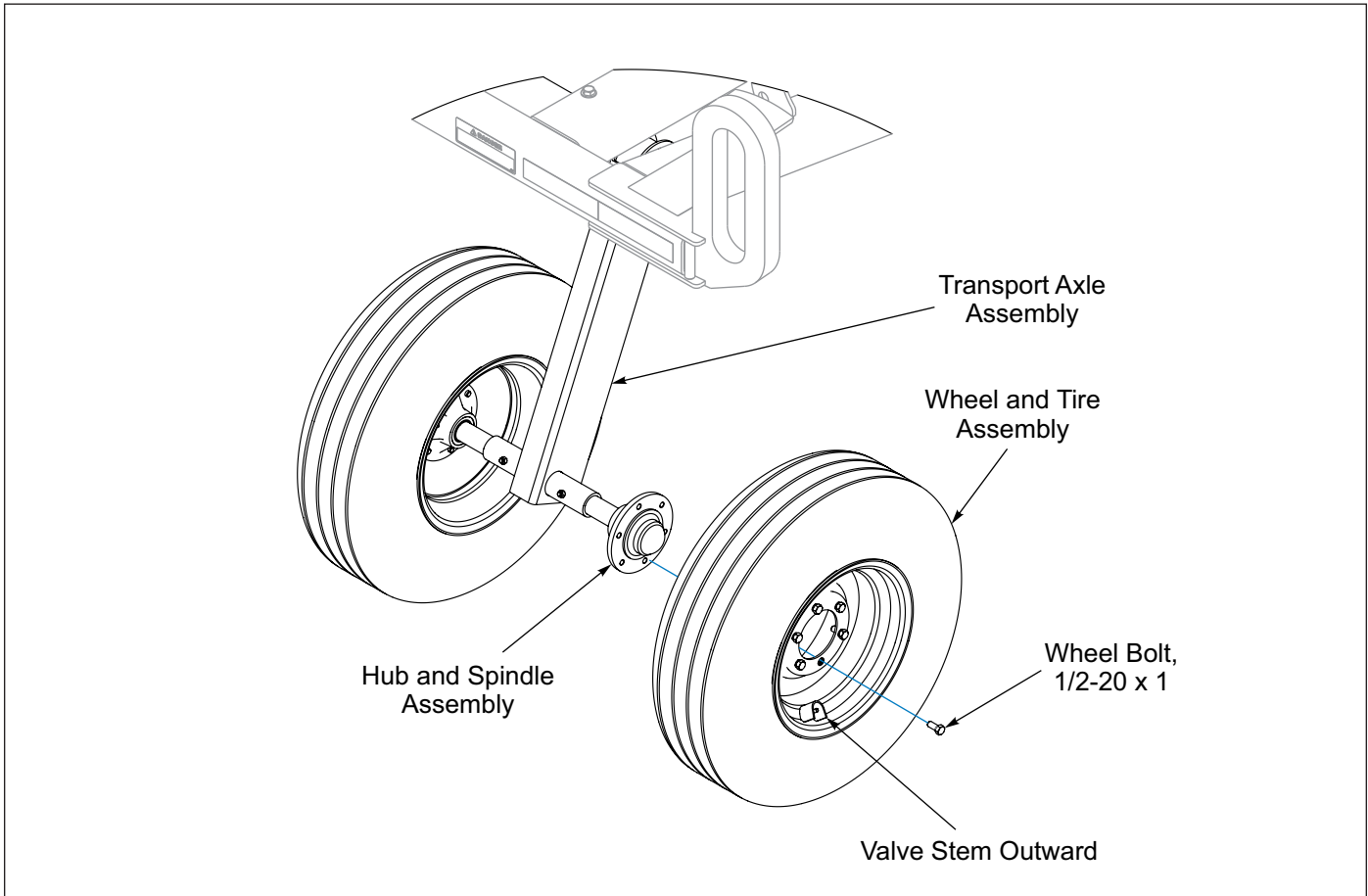

Figure 2-4: Tire and Wheel Assembly

Center Frame Roller Installation

NOTE

Wheel Stop is on the Clamp side of the Roller Assembly

NOTE

Crowfoot Wheel Rotation Arrow must follow the direction of travel. See Figure 2-5.

Roller Assemblies are pre-assembled from the factory with trunnion bearings, shims, and retaining washers. Crowfoot Wheel Rotation Arrow must follow the direction of Travel. See Figure 2-5.

1. Loosen the 1-8 Bolt on each end of the Roller Assembly approximately 4 turns.
2. With the Bearing Grease Fitting facing towards the rear of the machine, slide the Trunnion Bearing Mounts onto the Trunnion Bearings and lift the Roller Assembly up to the Center Frame Bearing Hangers. Hand tighten 3/4-10 hardware to hold Trunnion Bearing Mounts in place. See Figure 2-7.
3. Look at each Trunnion Bearing Mount to make sure that it is sitting perpendicular to the Center Frame Bearing Hanger. See Figure 2-6. If not adjust the Shim Washers accordingly, for each side there are two 11ga and one 14ga Shim Washers. Shim Washers can be all three on the inside between the Stub Shaft shoulder and the Trunnion Bearing, all three can be on the outside between the Trunnion Bearing and Flat Top Washer, or a combination on either side, but all three must be used to minimize the gap. If gap cannot be properly minimized with bearing snap rings to outside, turn bearing around to have snap ring to inside. The bearing inner race is offset with respect to the trunnion bosses by 1/32". By installing bearings with snap rings in versus out, 1/16" difference can be made up at assembly if needed.
4. Tighten 3/4-10 and 1-8 hardware to specification per torque chart. See Page 4-1.

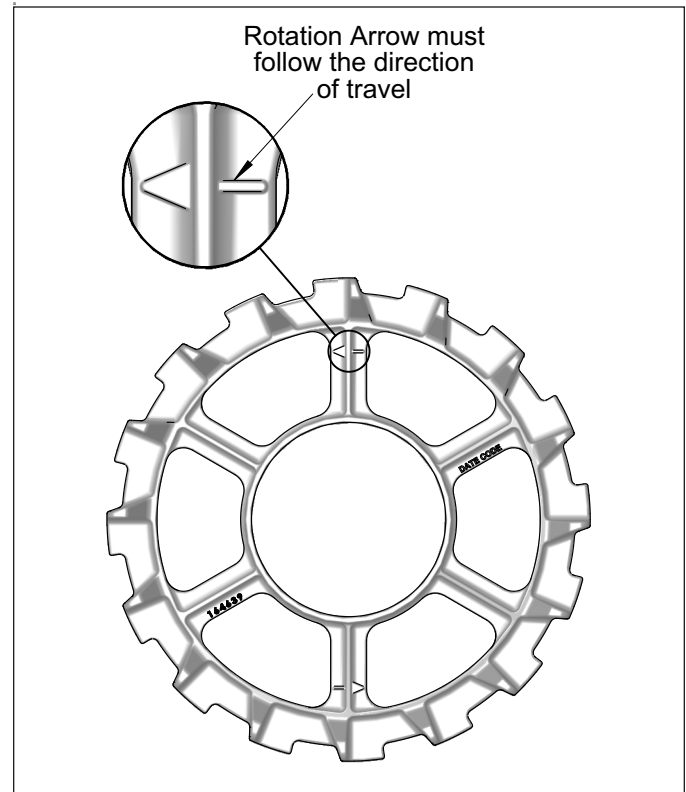

Figure 2-5: Crowfoot Wheel Rotation

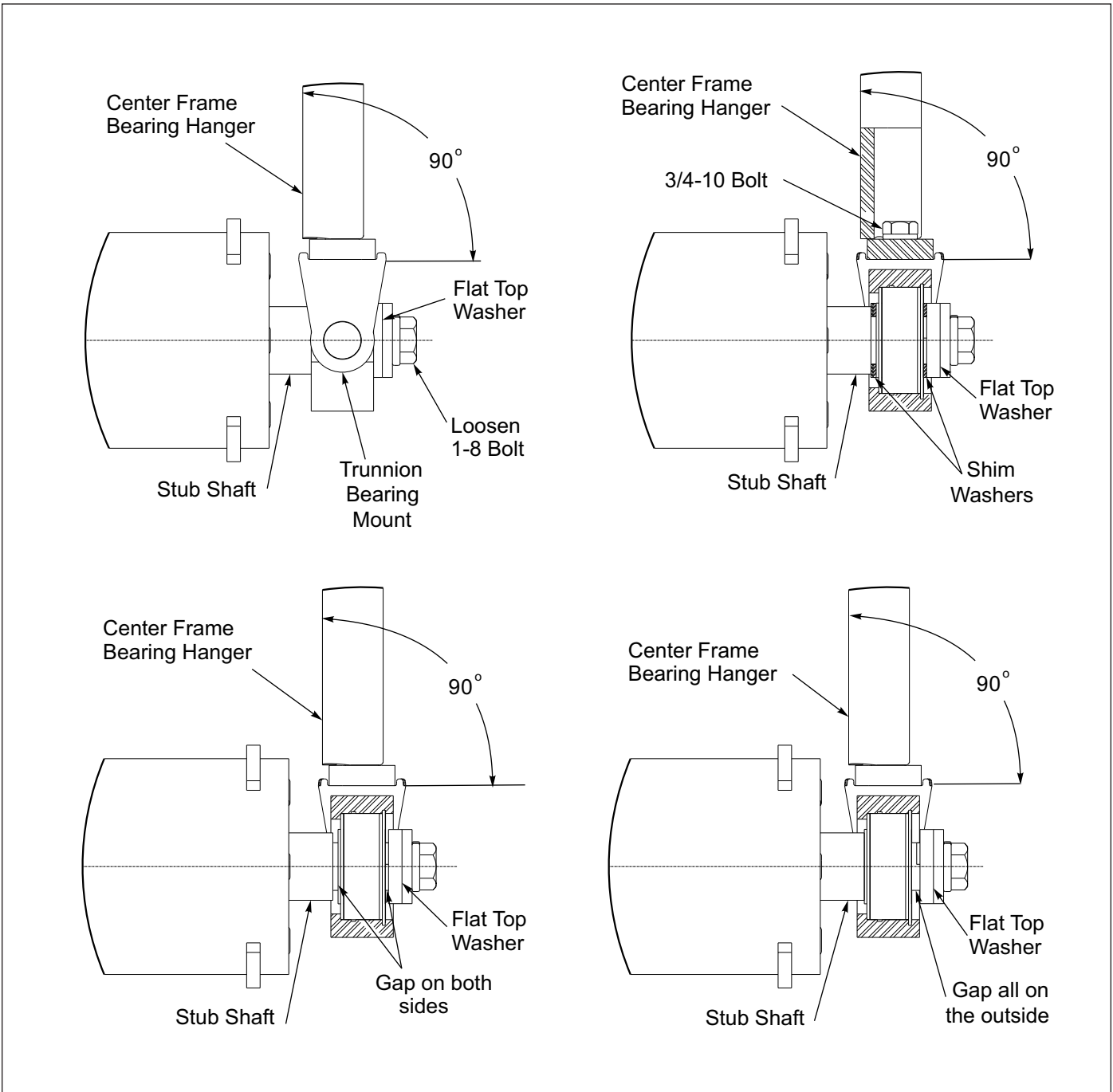

Figure 2-6: Trunnion Spacing

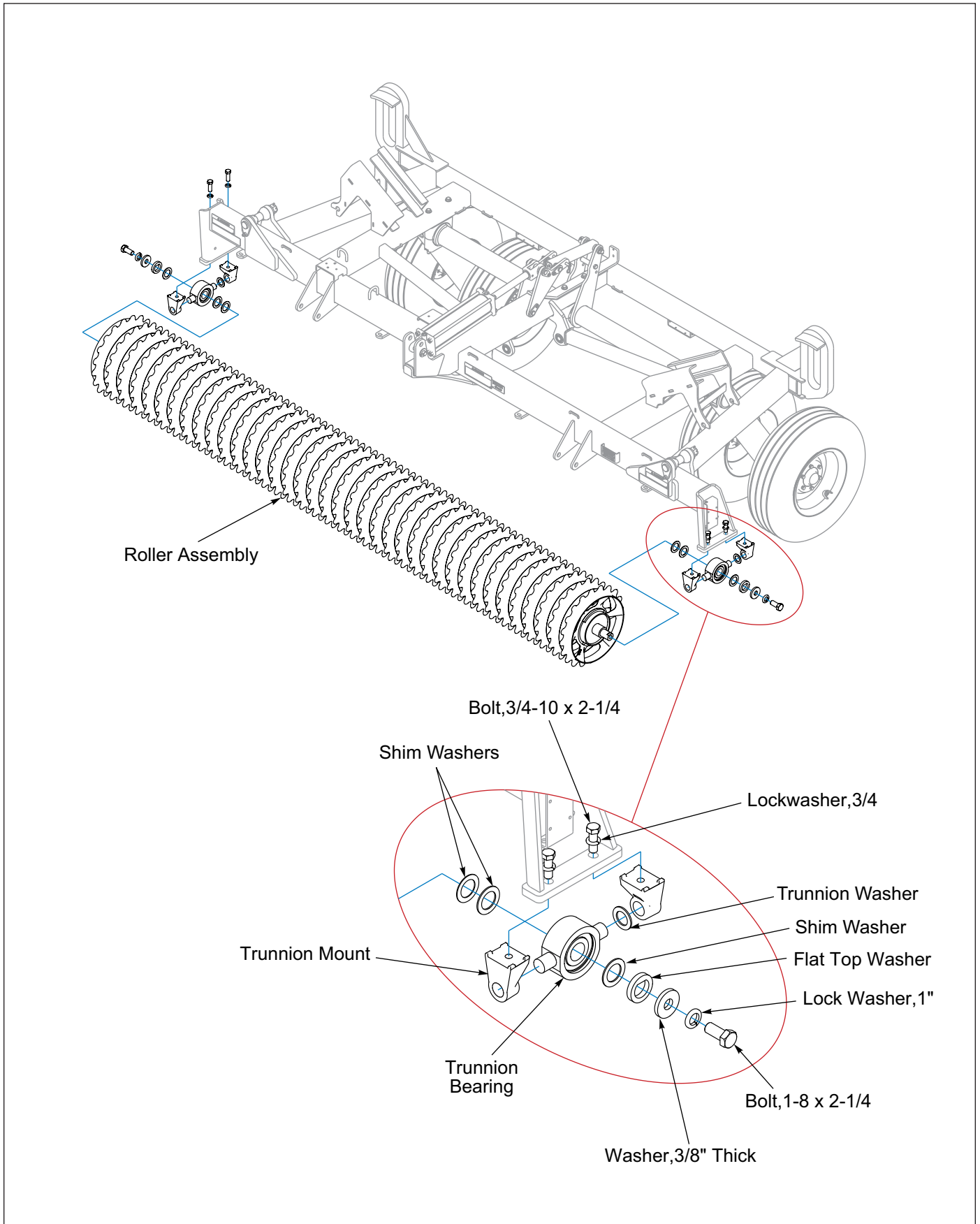

Figure 2-7: Center Frame Roller Installation

Drawbar Installation

1. Attach Drawbar to Center Frame with 1 x 8 Pin. Place a 1" Flat Washers on each side of pin. Secure with 5/16 x 2 Roll Pin and Klik Pin.
2. Attach Turnbuckle to Center Frame and Drawbar with 1 x 5-1/2 Pin. Place a 1" Flat Washer on each side of Pin. Secure with 5/16 x 2 Roll Pin and Klik Pin.

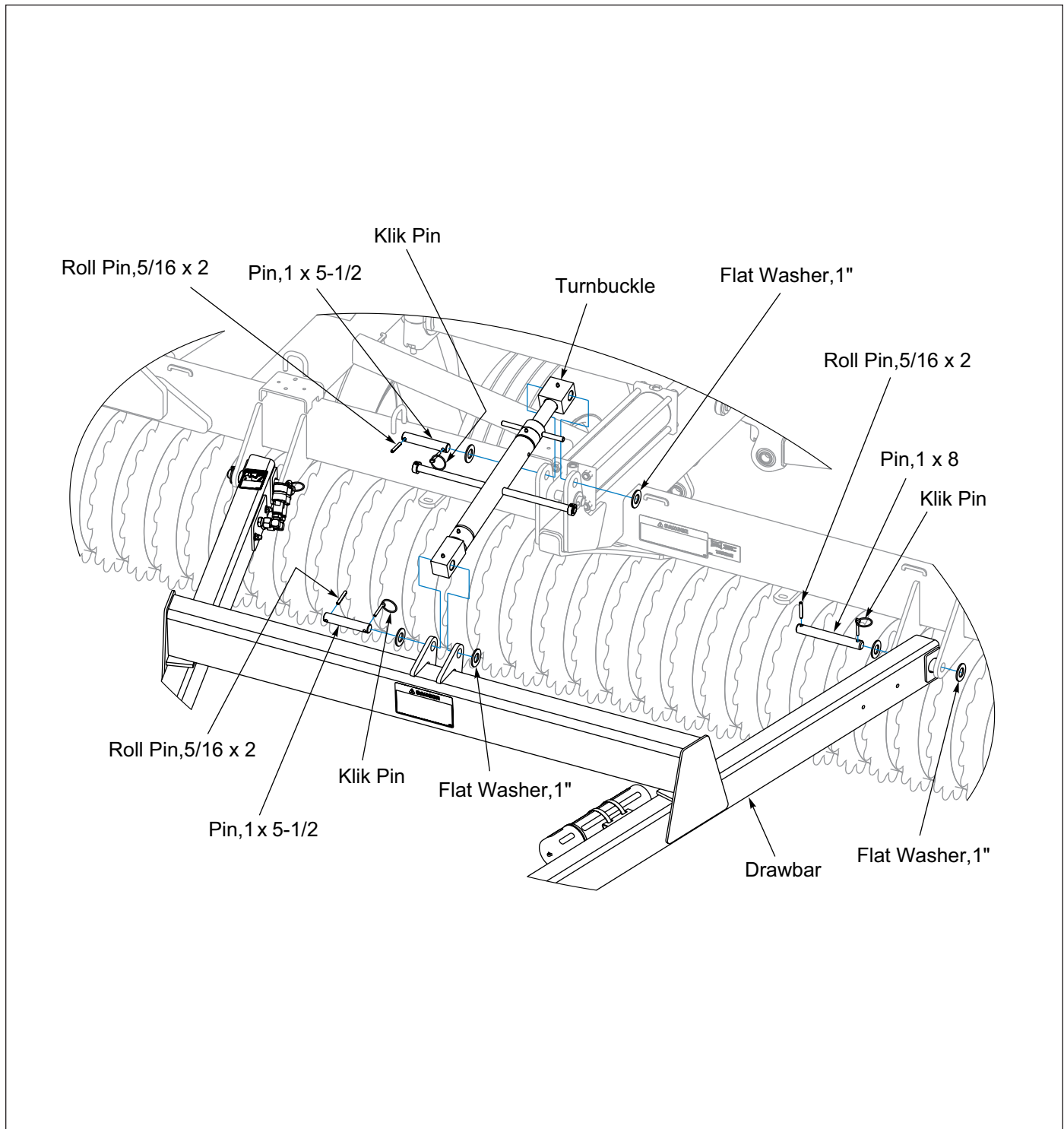

Figure 2-8: Drawbar Installation

Drawbar Jack, Hose Support and Manual Storage Canister Installation

1. Assemble the Jack Mount to the Jack with 1/2-13 x 1-1/2 Bolts and Locknuts in the four upper holes. Attach the Jack to the drawbar by slipping the Jack sleeve into the Drawbar sleeve and inserting the Jack 3/4 Pin with Chain.

2. Attach the Hose Support to the Drawbar with 5/8-11 x 2 1/4 Bolt, 5/8 x 2 x 3/8 Washer and Flange Locknut.
3. Install the Manual Storage Canister to the Drawbar Mount with Hose Clamp.

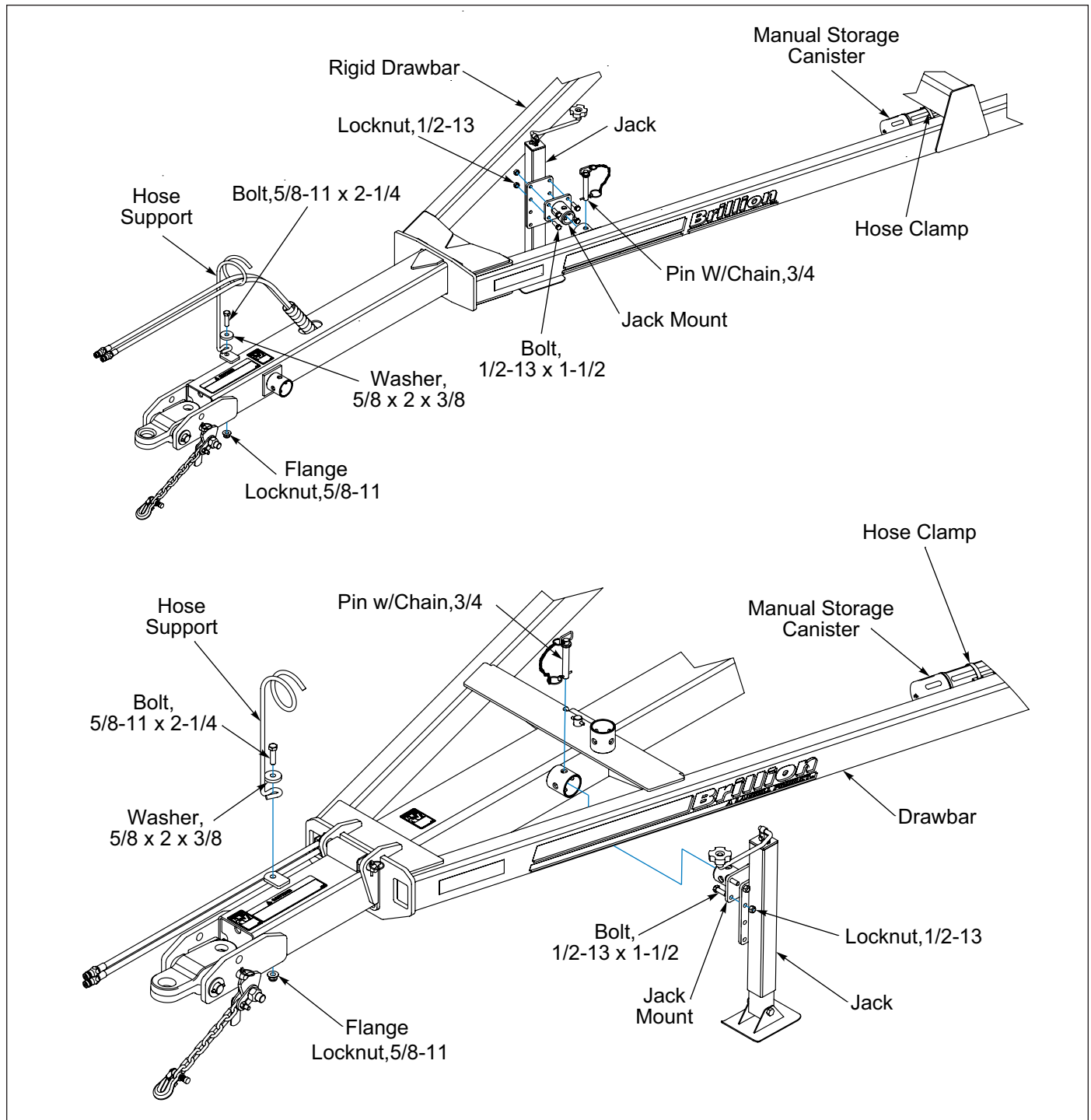

Figure 2-9: Drawbar Accessories Installation

Wing Fold Cylinder Installation

NOTE

Be sure the Hydraulic Cylinder ports are positioned properly.

1. Check to make sure that the Center Frame Ball Joints are free to rotate.
2. Apply anti-seize to Frame Ball Joints.
3. RH Cylinder ports are front facing and LH Cylinder ports are rear facing. **See Figure 2-10.** Attach base end of the 4 x 36 Hydraulic Cylinder (**WFP23-29**) or 4-1/2 x 36 Hydraulic Cylinder (**WFP31-37**) to the Center Frame Ball Joints with the vendor supplied hardware.
4. Block Cylinder Rod ends up from the frame to allow for rod movement when purging the Hydraulic Circuit.

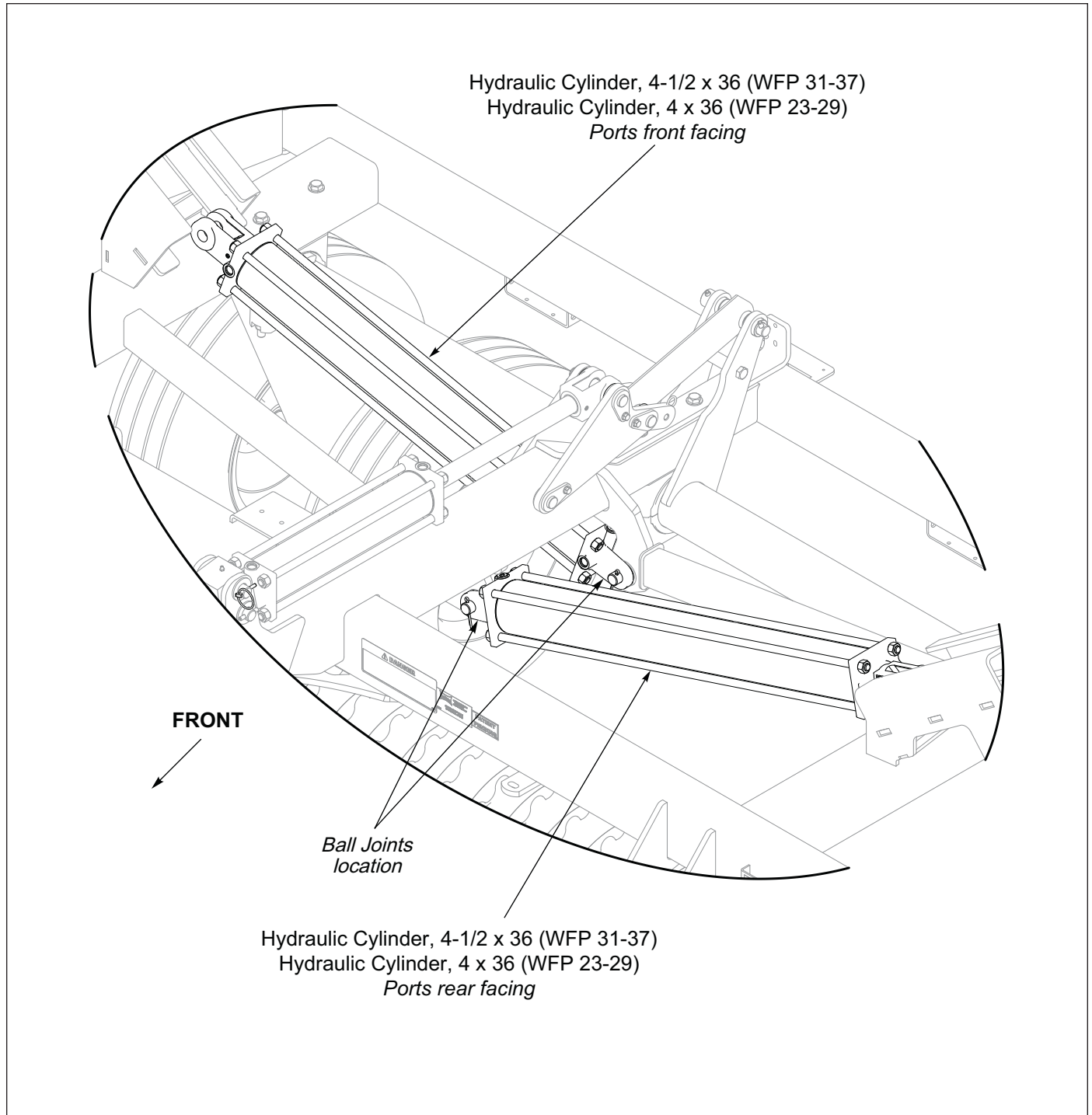

Figure 2-10: Wing Fold Cylinder Installation

Hydraulic Installation

IMPORTANT

Unfold and lower the unit to the ground and relieve system pressure before attempting to repair, adjust, or disconnect components.



WARNING

Escaping fluid under pressure can be nearly invisible and have enough force to penetrate the skin causing serious injury. Use a piece of cardboard, rather than your hands, to search for suspected leaks. Wear protective gloves & safety glasses or goggles when working with hydraulic systems. Keep all components (cylinders, hoses, fittings etc.) in good repair.

The Wing Float Pulverizer consists of a single circuit that folds and lifts the machine. The Hydraulic Circuit requires approximately 4-1/2 to 6 gallons of hydraulic oil depending on the Model.

Tightening Procedure For JIC 37° Swivel Female Nuts

1. Check flare and seat for defects.
2. Lubricate the connection.
3. Install hoses without twists.
4. Hand tighten until connection bottoms.
5. Using 2 wrenches to prevent twisting, rotate the swivel nut 2 wrench flats (1/3 turn).
6. For reassembly, follow the same procedure but tighten only 1 wrench flat (1/6 turn).

Tightening Procedure For Swivel O-Ring Fittings

1. Lubricate O-Ring and install the fitting until the metal washer which backs up the O-Ring contacts the face of the boss.
2. Orient the fitting by turning counterclockwise up to 1 turn.
3. Tighten the lock nut using 50-60 foot pounds torque. (See "Hydraulic Fitting Torque Specifications" on page 4-2.)

Plumb the Hydraulic Circuit



CAUTION

Restrictors are installed in both the rod and base end of wing fold cylinders to prevent uncontrolled dropping of wings. Removal of these restrictors, or improper installation can result in serious damage to the implement.

Refer to **Figure 2-14** and **2-15**.

1. Install a Female Swivel x Male O-Ring Elbow Fitting onto each Drawbar Bulkhead. See **Figure 2-11**.
2. Install Female Coupler onto each Elbow Fitting
3. Attach Manifold to the Frame Bracket with 5/16-18 x 3 Bolts and Locknuts.

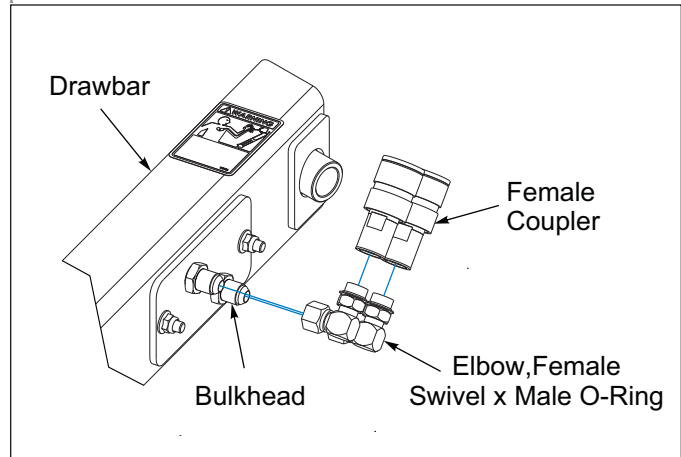

Figure 2-11: Female Coupler Installation

4. Lubricate Relief Valve Cartridge and Shut-off Valve Cartridge O-Rings. Install the cartridges into the Manifold torquing the Relief Valve Cartridge to 24-26 Ft-Lbs and the Shut-off Valve Cartridge to 19-21 Ft-Lbs. See **Figure 2-12**.

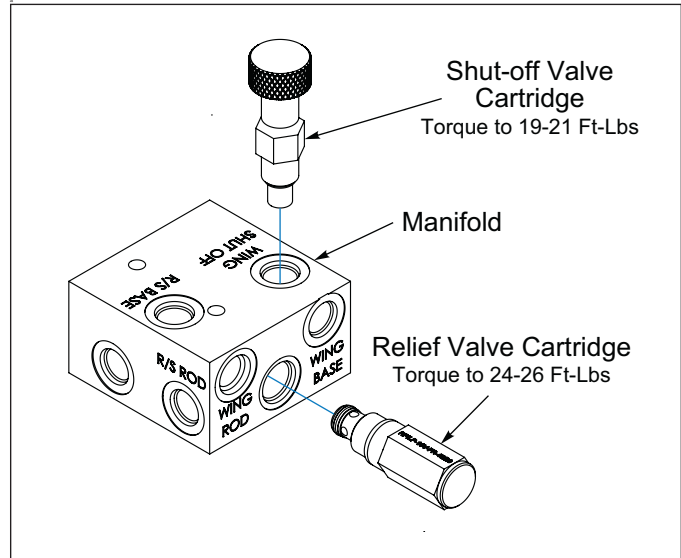

Figure 2-12: Manifold Valve Assembly

5. Install all the other Hydraulic Fittings into the Manifold. See **Figure 2-15**.
6. Install Restrictors into the fold Cylinder ports and install an Elbow Fittings onto the Restrictors.
7. Install the Elbow Fittings into the Lift Cylinder ports.
8. Attach Hoses to the Cylinders and Manifold.
9. Install Male Couplers on the ends of the Male O-Ring Hose Ends and insert them into the Female Coupler.

NOTE

The Magnet Hose Holder is used to prevent hoses from dragging with the extended Drawbar.

10. Telescoping Drawbars: Assemble the Magnet, Hose Clamp, Handle and Hardware to the Drawbar Hoses halfway between the Drawbar A-Frame and Hose Support. **See Figure 2-13.**

11. Secure all hoses with tie wraps.

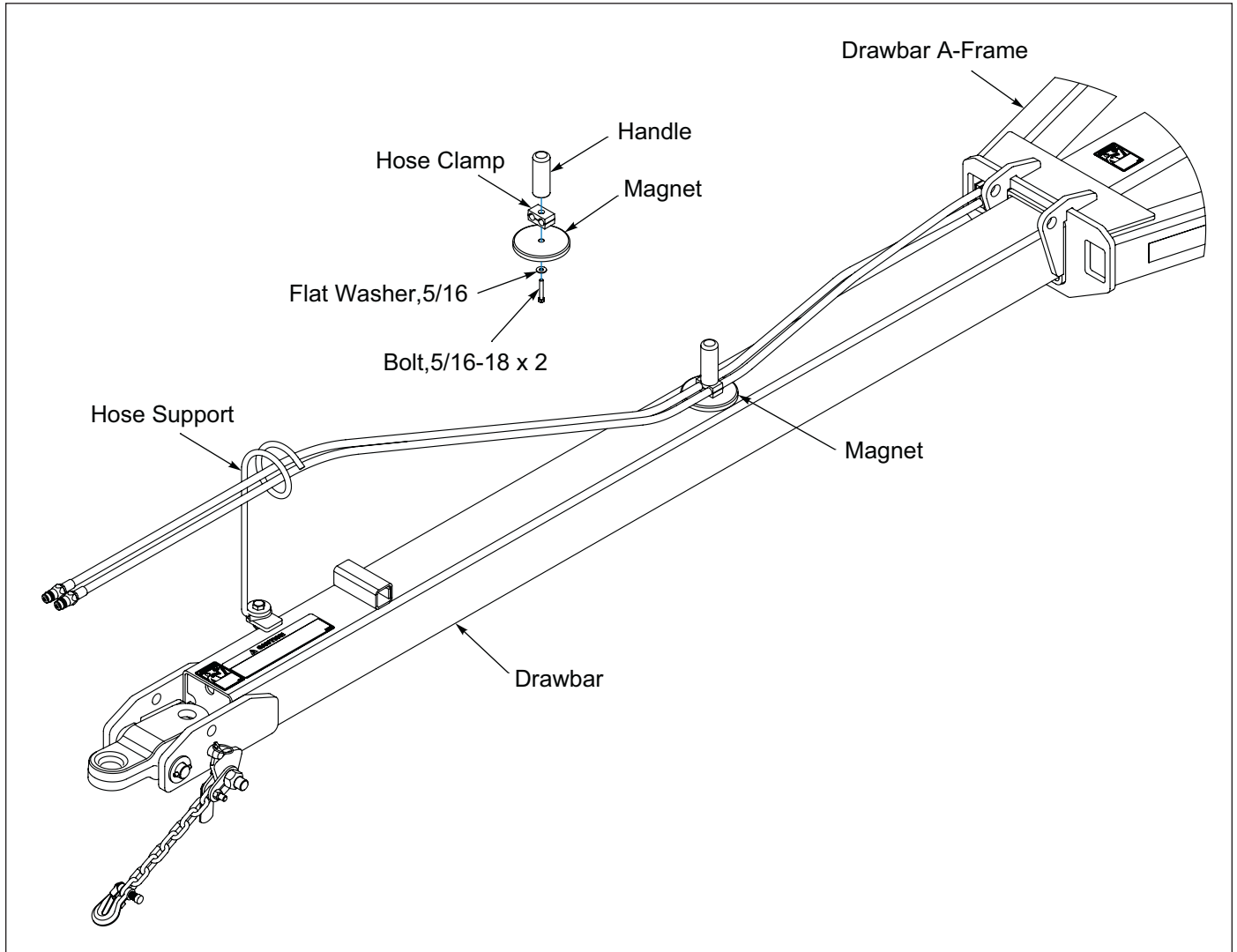

Figure 2-13: Telescoping Drawbar Magnet Hose Holder

Purging the Hydraulic System

IMPORTANT

Unfold and lower the unit to the ground and relieve system pressure before attempting to repair, adjust, or disconnect components.



WARNING

Escaping fluid under pressure can be nearly invisible and have enough force to penetrate the skin causing serious injury. Use a piece of cardboard, rather than your hands, to search for suspected leaks. (See Figure 2-16.) Wear protective gloves & safety glasses or goggles when working with hydraulic systems. Keep all components (cylinders, hoses, fittings etc.) in good repair.

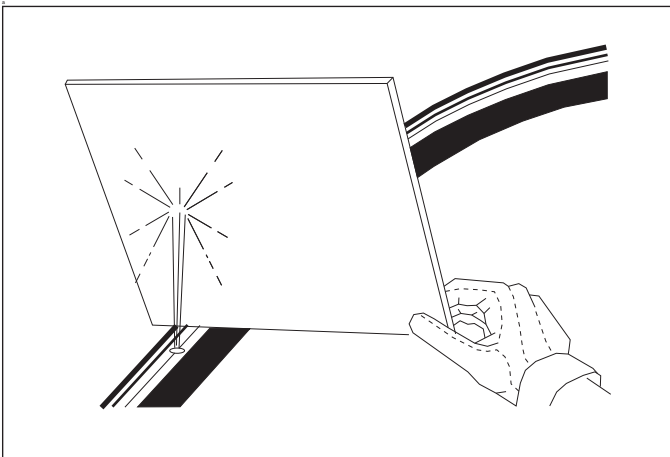

Figure 2-16: Hydraulic Leak Detection

The hydraulic system is not filled with oil and should be purged of air before transporting and field operations. Carefully hitch the Pulverizer to the tractor and connect the Hydraulic Hoses. Check to make sure the tractor hydraulic reservoir is full of the manufacturer's recommended oil.

Block each Fold Cylinder Rod End up to allow for rod movement. Completely extend and retract Fold and Lift Cylinders. Recheck tractor oil reservoir. Extend and retract the Cylinders completely 5-6 times to purge air from the Hydraulic Circuit. Do not loosen hoses/fittings. Recheck tractor reservoir oil level. Hydraulic Circuit requires approximately 4-1/2 to 6 gallons of hydraulic oil depending on the Model. After the Hydraulic Circuit has been purged, leave the Wing Cylinders extended for Wing Installation.

Wing Installation

1. Assemble the Wings onto the Center Frame. **See Figure 2-17.** At the rear of the Center Frame, slide the RH or LH Wing Guide Roller into the Center Frame Yoke/Guide. At the front of the Center Frame, place a Spacer on each side of the Spherical Bearing, positioning it between the Center Frame Lugs.
2. Insert 1-3/4 Threaded Pin, place Thick Washer and hand tighten Slotted Nut. Secure 1-3/4 Threaded Pin by inserting 1/2-13 x 2-1/4 Bolt from the inside out with the Locknut on the front.
3. Torque Slotted Nut initially to 350 Ft-Lbs. If nut slot is not aligned with slotted pin hole in Threaded Pin, tighten nut up to 400 Ft-Lbs to align next slot. Install 1/4 x 2-1/2 Cotter Pin.
4. Install a 1/8 NPT Zerk Fitting into each Wing Guide Roller Pin.
5. Attach the Wing Fold Links, with the straight edge away from the Wing Hinge Tube, to the Wing Frame by placing the Links between the two Wing Frame Hinge Lugs. Place a 1.66 x 2-3/4 Bushing between the Links. Align and insert 1-1/4 x 7-5/16 Pin. Place a Flat washer on each side of the Pin. Secure with 5/16 x 2 Roll Pins.
6. On each side, attach the Fold Hydraulic Cylinder to the Wing Fold Links by placing one Link on each side of the Hydraulic Cylinder Rod End Clevis and insert 1 x 10-1/8 Pin.
7. Note the different Bushing lengths between the Wing Fold Links and Roller Assemblies. On the rear, place a 1-1/2 x 11/16 Bushing against the Link followed by a Roller Assembly and a 1 x 2 x 11ga SS Flat Washer. On the front, place a 1-1/2 x 1-3/4 Bushing against the Link followed by a Roller Assembly and a 1 x 2 x 11ga SS Flat Washer. Secure with 5/16 x 2 Roll Pins.

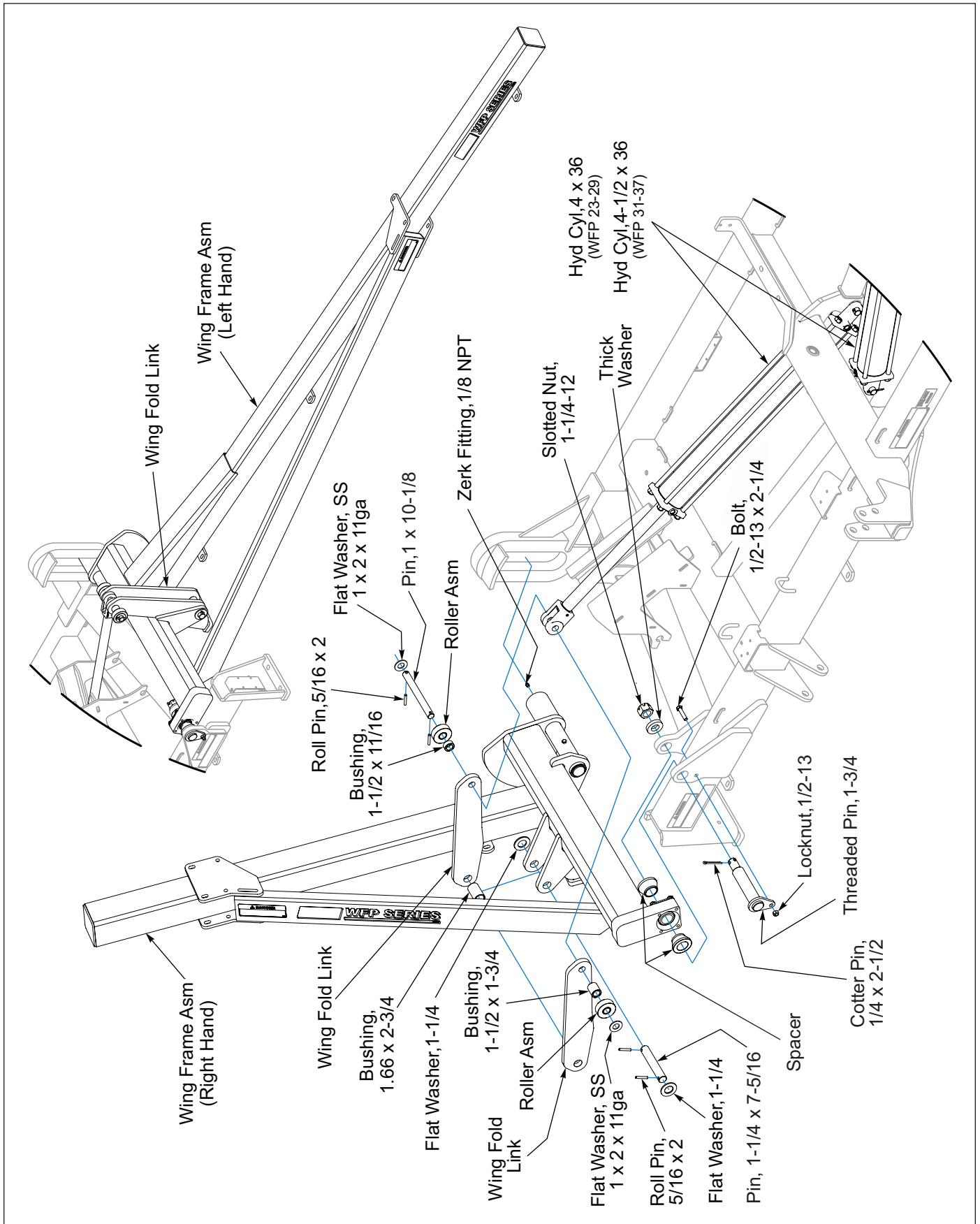

Figure 2-17: Wing Installation

Wing Frame Roller Installation

NOTE

Wheel Stop is on the Clamp side of the Roller Assembly

NOTE

Roller Axle Assembly clamped end must be on the outer extremity of the Wing.

NOTE

Crowfoot Wheel Rotation Arrow must follow the direction of travel. See Figure 2-18.

Roller Assemblies are pre-assembled from the factory with trunnion bearings, shims, and retaining washers. Crowfoot Wheel Rotation Arrow must follow the direction of travel. **See Figure 2-18.**

1. Support Wing Frame outer end from above the Frame.
2. Place Bearing Hanger Clamp on the top of the Wing Frame Tube and assemble the bolt on Bearing Hanger on the end of the Wing Frame with .5/8-11 x 7 Bolts and Flange Locknuts. Do not tighten. **See Figure 2-19.**
3. Position the Trunnion Bearings so the Grease Fitting faces the rear of the machine.
4. Place a Trunnion Washer on the Trunnion Bearing's rear facing boss with the grease fitting. Slide the Trunnion Bearing Mounts onto Trunnion Bearings
5. Lift the Roller Assembly up to the Wing Frame Bearing Hangers and attach Trunnion Mounts with 3/4-10 x 2-1/4 Bolts and Lock Washers. Tighten Inner Trunnion Mounts first, then outer Trunnion Mounts.
6. Tighten outer bolt on Bearing Hanger making sure it pulls up evenly, adjust as needed to minimize end loading the Trunnion Bearings.

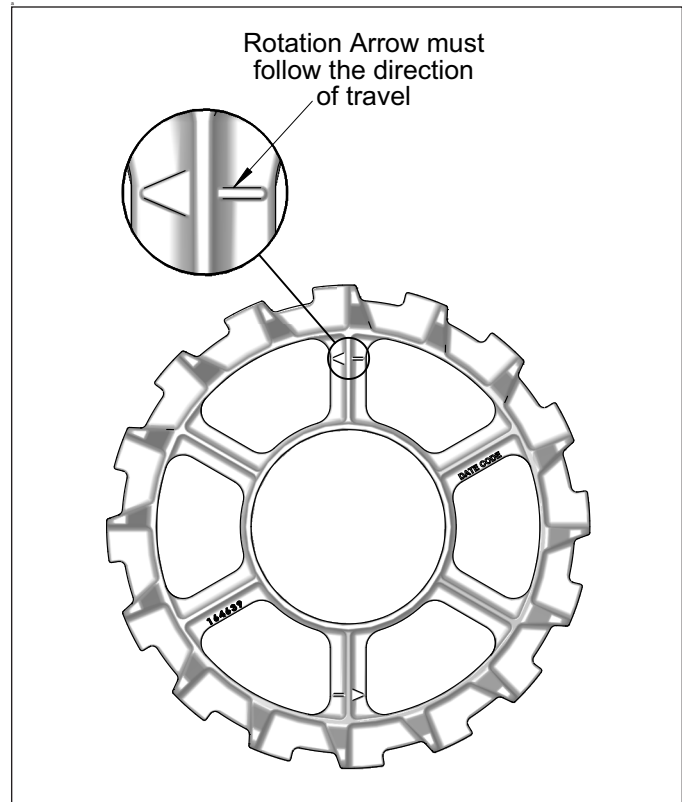

Figure 2-18: Wheel Rotation

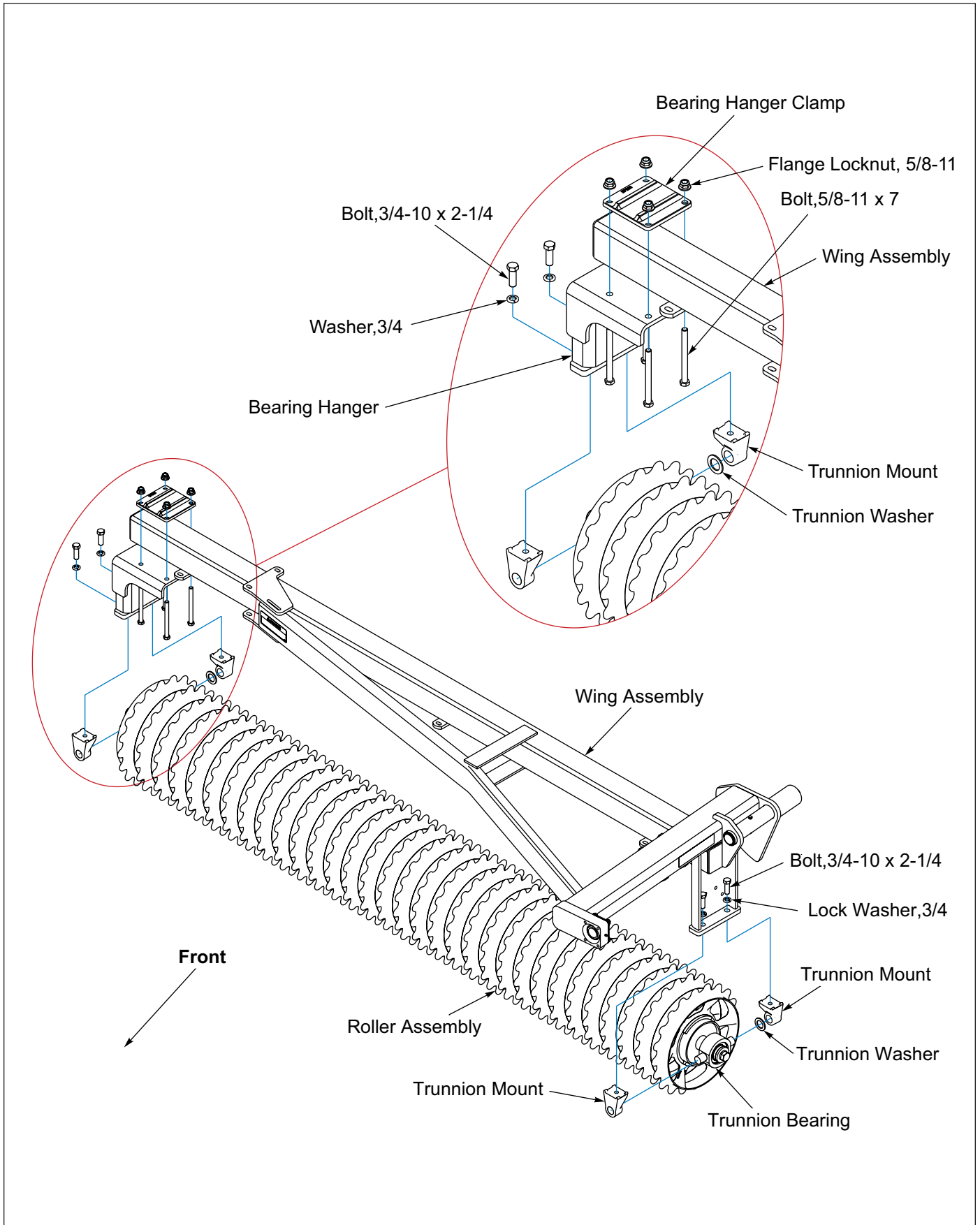

Figure 2-19: Wing Frame Roller Installation

Wing Rest Installation, WFP 23-29

1. Install the RH Wing Rest to the RH Wing Frame 4-Hole Plate located on the top of the Wing Frame Tube. Secure with 1/2-13 x 2 Bolts, Flat Washers and Flange Locknuts. **See Figure 2-20.**
2. Install the LH Wing Rest LH to the LH Wing Frame 4-bolt Plate located on the side of the Wing Frame.

Secure with 1/2-13 x 2 Bolts, Flat Washers and Flange Locknuts.

3. Attach the Wing Rest Bumper Pads onto the top of the RH and LH Wing Rest with 3/8-16 x 1-1/2 Flat Head Screws and Locknuts.

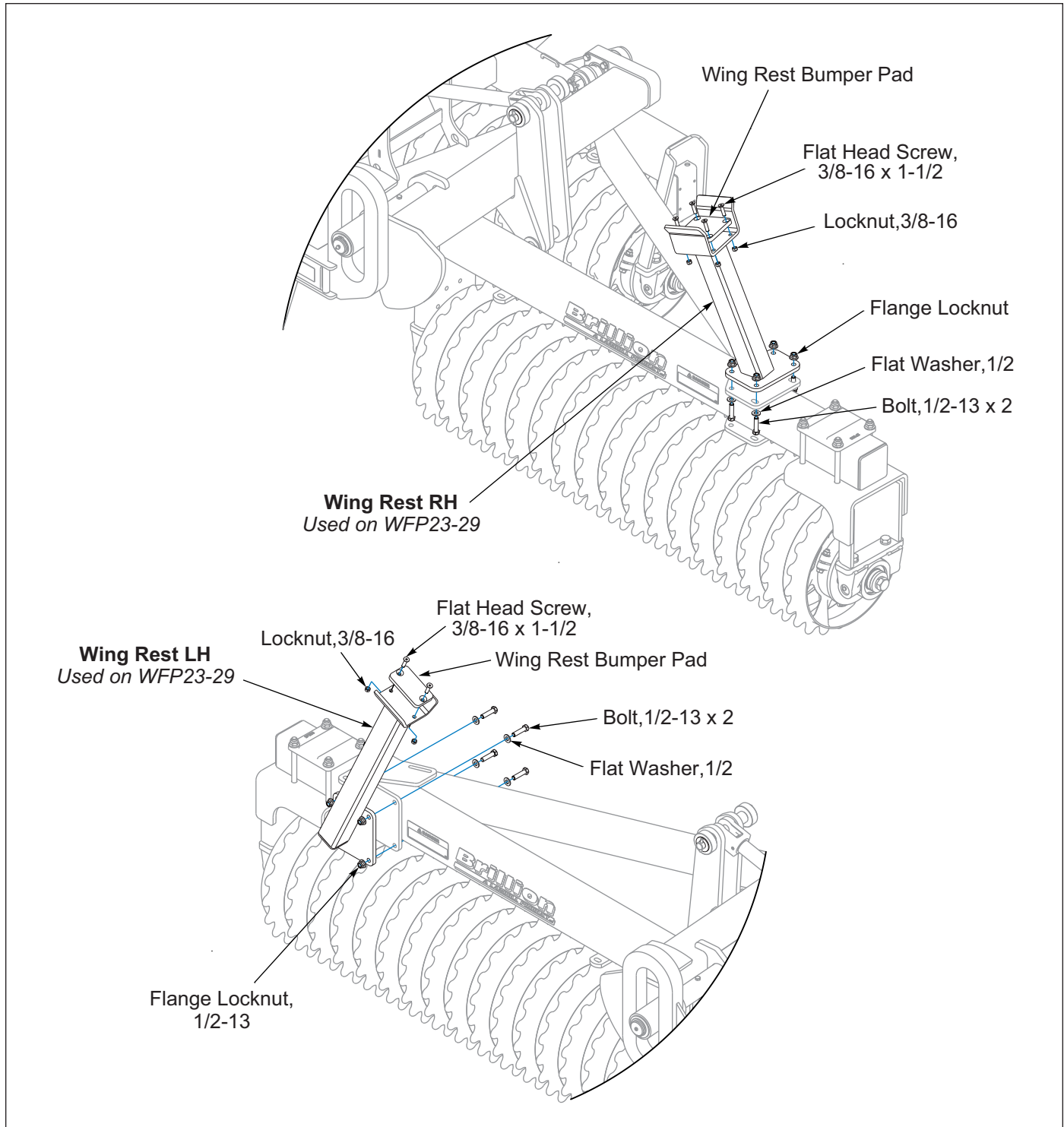

Figure 2-20: Wing Rest Installation, WFP 23-29

Wing Rest Installation, WFP 31-37

1. Install the RH and LH Wing Rest to the RH and LH Wing Frame 4-Hole Plate located under the Wing Frame Tube. Secure with 5/8-11 x 7 Bolts, Flat Washers and Flange Locknuts. **See Figure 2-21.**
2. Attach the Wing Rest Bumper Pads onto the top of the RH and LH Wing Rest with 3/8-16 x 1-1/2 Flat Head Screws and Locknuts.

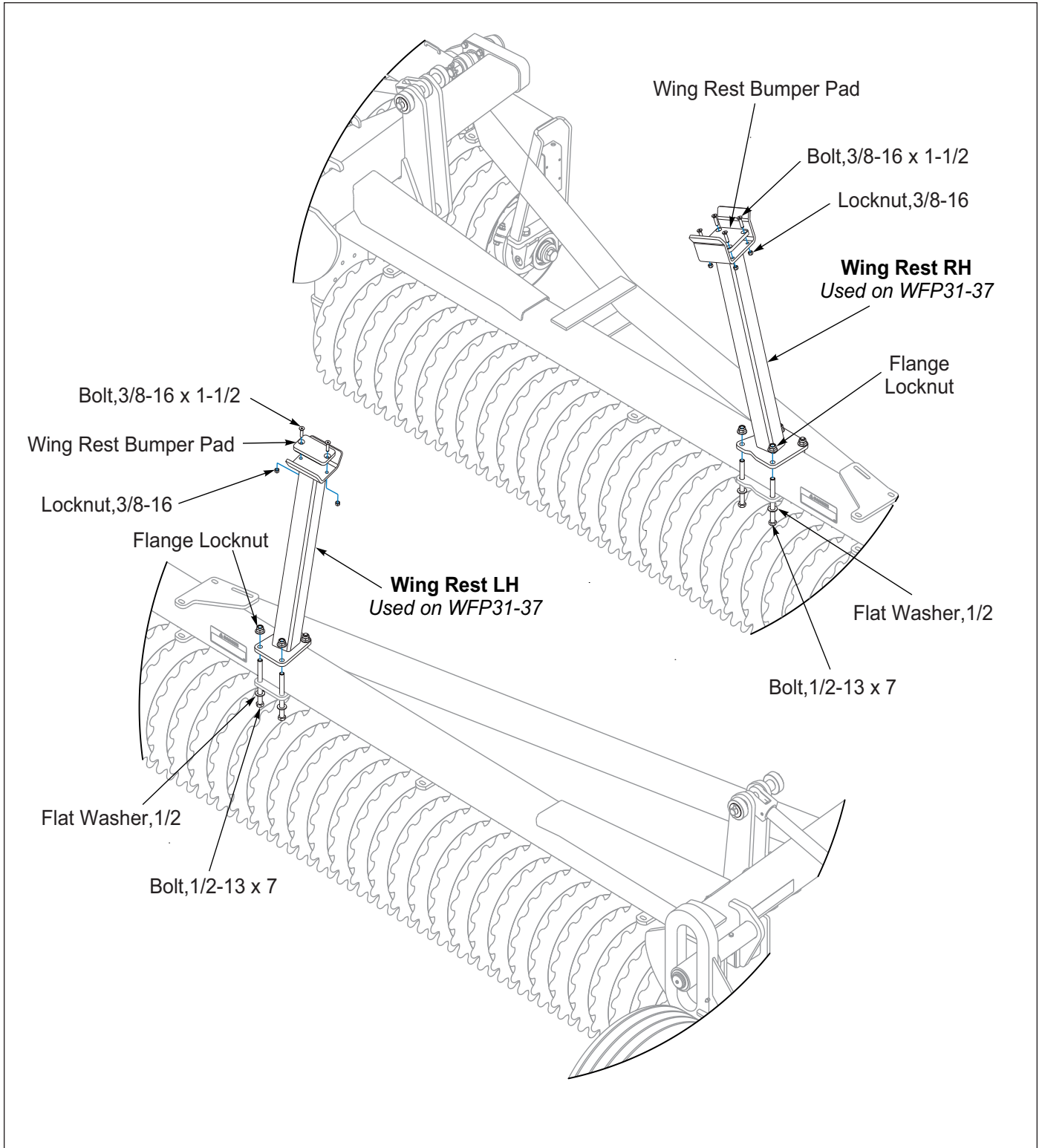

Figure 2-21: Wing Rest Installation, WFP 31-37

Warning Lamp Installation

NOTE

Be sure when assembling Lamps onto Brackets that the wires are not pinched when tightening hardware.

1. Attach Red Lamps to Frame Light Brackets located under the Rear Center Frame Tube, using 1/4-20 x 1-1/2 Bolts and Locknuts. Ensure the Red Lens is rear facing. **See Figure 2-22.**
2. Place the Amber Lamps inside the Light Shields, ensure 2 prong plug sticks out the light shield slot opening. Attach an Amber Lamp and Shield to Frame Light Brackets located on Center Frame Bearing Hangers with 1/4-20 x 1-1/2 Bolts and Locknuts.
3. Attach the Light Module under the Frame Light Module Mount located on top of the Front Center Frame Tube with 1/4-20 x 1-1/2 Bolts and Locknuts.
4. Route the flat end of the 7-Pin Harness inside and through the right side of the Drawbar Frame. Connect Harness to the Light Module. Route the Harness 7-Pin Plug end with the Hydraulic Hoses down the Drawbar and through the Hose Support.

IMPORTANT

Cords are marked Left (Yellow Tape) and Right (Green Tape).

5. Lay out the Lamp Harness, noting that the connectors marked with Green Tape is Right Side and Yellow Tape is Left Side. Plug the Lamp Harness into the Flasher Control Module.
6. Route the 2 prong plug Green Tape cord along the right side of the Front Frame Tube and the 2 prong plug Yellow Tape cord along the left side of the Front Frame Tube. Plug the cords into the Amber Lamps.
7. Route the 3 prong plugs, Green and Yellow cords, down the Frame Cross Tube and the Rear Frame tube to the first Red Lamp. Connect Green cord to RH Red Lamp. Continue running the Yellow cord along the Rear Frame Tube to LH Red Lamp and connect.
8. Bundle and secure excess cord to the Light Brackets with Tie Wraps. Secure both Harnesses with Tie Wraps along the frame and Hydraulic Hoses making sure to leave enough slack where the Drawbar meets the Frame for the machine to raise and lower.
9. Raise, lower, fold and unfold machine to check for proper clearance, adjust accordingly.

NOTE

All Harnesses must be firmly attached to machine frame members or Hydraulic Hoses so they do not sag or become torn loose by field debris. Use the tie wraps provided. Check to be sure the Harnesses is slack enough so as to not be stretched or interfered with while raising and lowering of the machine.

SMV Sign Installation

Attach the SMV sign to Bracket located on the Rear Frame Tube with 5/16-18 x 1 Bolts, Flat Washers and Locknuts.

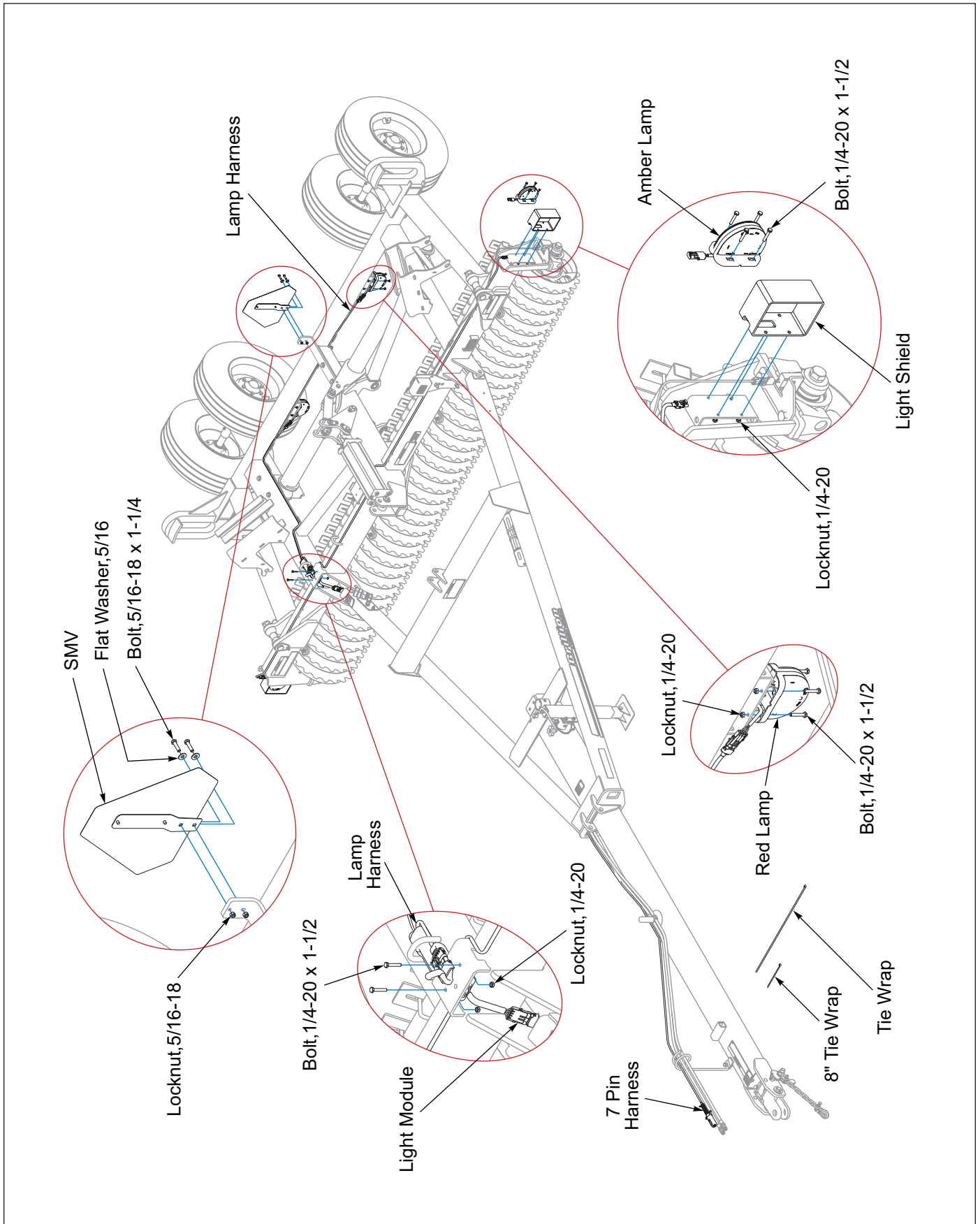

Figure 2-22: Warning Lamp Installation

Center Roller Scrapers - Optional

NOTE

A scraper can be used as a guide to achieve the 1/4" gap.

1. With Rollers on level ground. Install center Scraper Mounts to Center Frame Mounts with 1/2-13 x 1-3/4 Carriage Bolts and Flanged Locknuts. Do not tighten. **See Figure 2-23.**
2. Center Scraper Tube on the Roller Assembly and attach to the Center Scraper Mounts with 1/2-13 U-Bolts and Flange Locknuts.

3. Attach a Scrapers at each end and the center of the Scraper Tube with 3/8-16 U-Bolts and Flange Locknuts, adjust the scrapers so that they are centered between the Notched Wheels along with a 1/4" gap between the Scraper and Notched Wheels. Tighten all the Scraper Mount Hardware.
4. Install the rest of the Scrapers onto the Scraper Tube with 3/8-16 U-Bolts and Flange Locknuts. The Scrapers should be centered between the Notched Wheels and have a 1/4" gap between the Scraper and Notched Wheels.

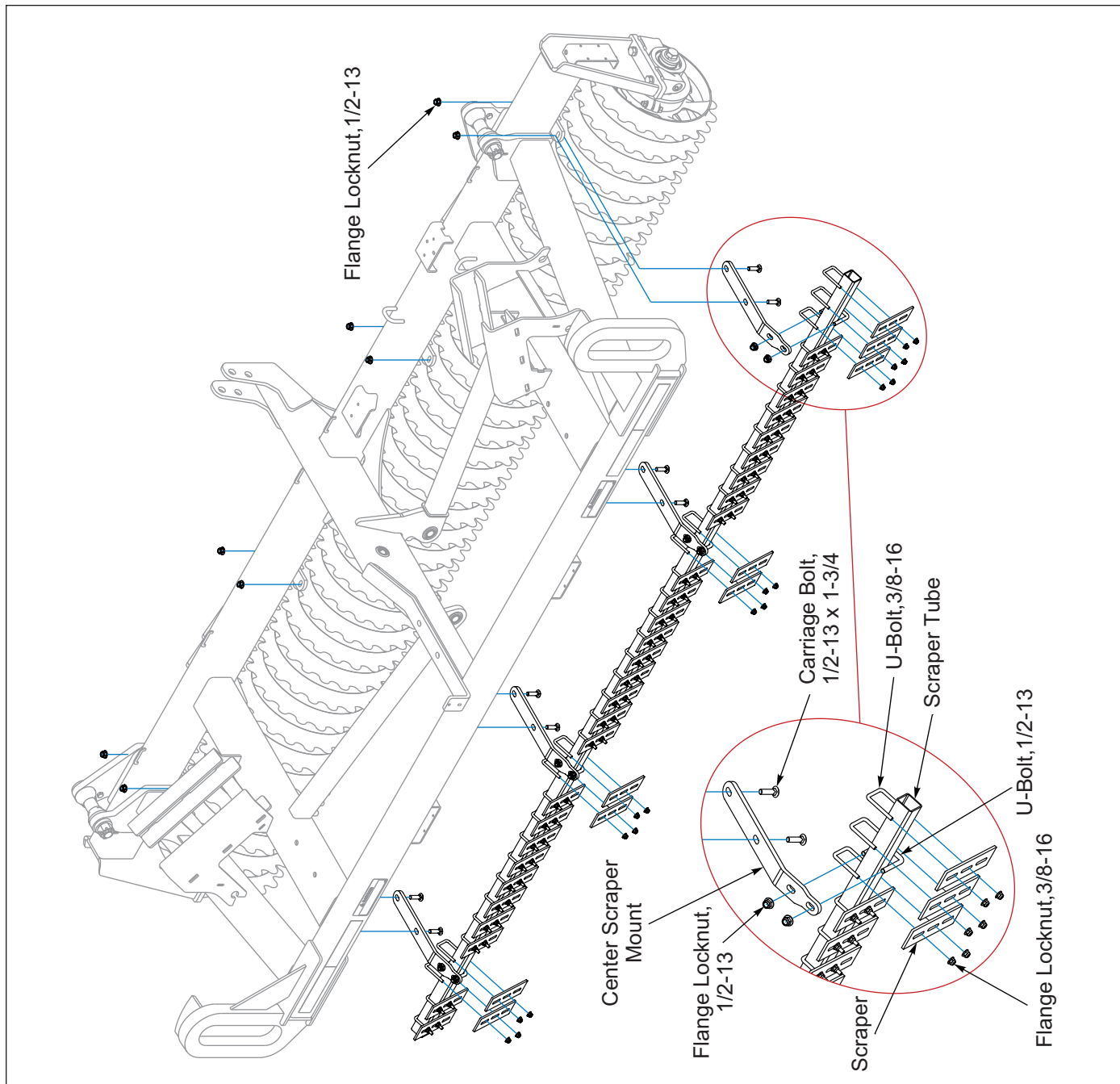

Figure 2-23: Center Roller Scrapers - Optional

Wing Roller Scrapers - Optional

With the Wing Rollers on level ground, install the Scrapers in the same manner that the Center Roller Scrapers were installed. **See Page 2-28 and Figure 2-24.** The Scrapers should be centered between the Notched Wheels and have a 1/4" gap between the Scraper and Notched Wheels.

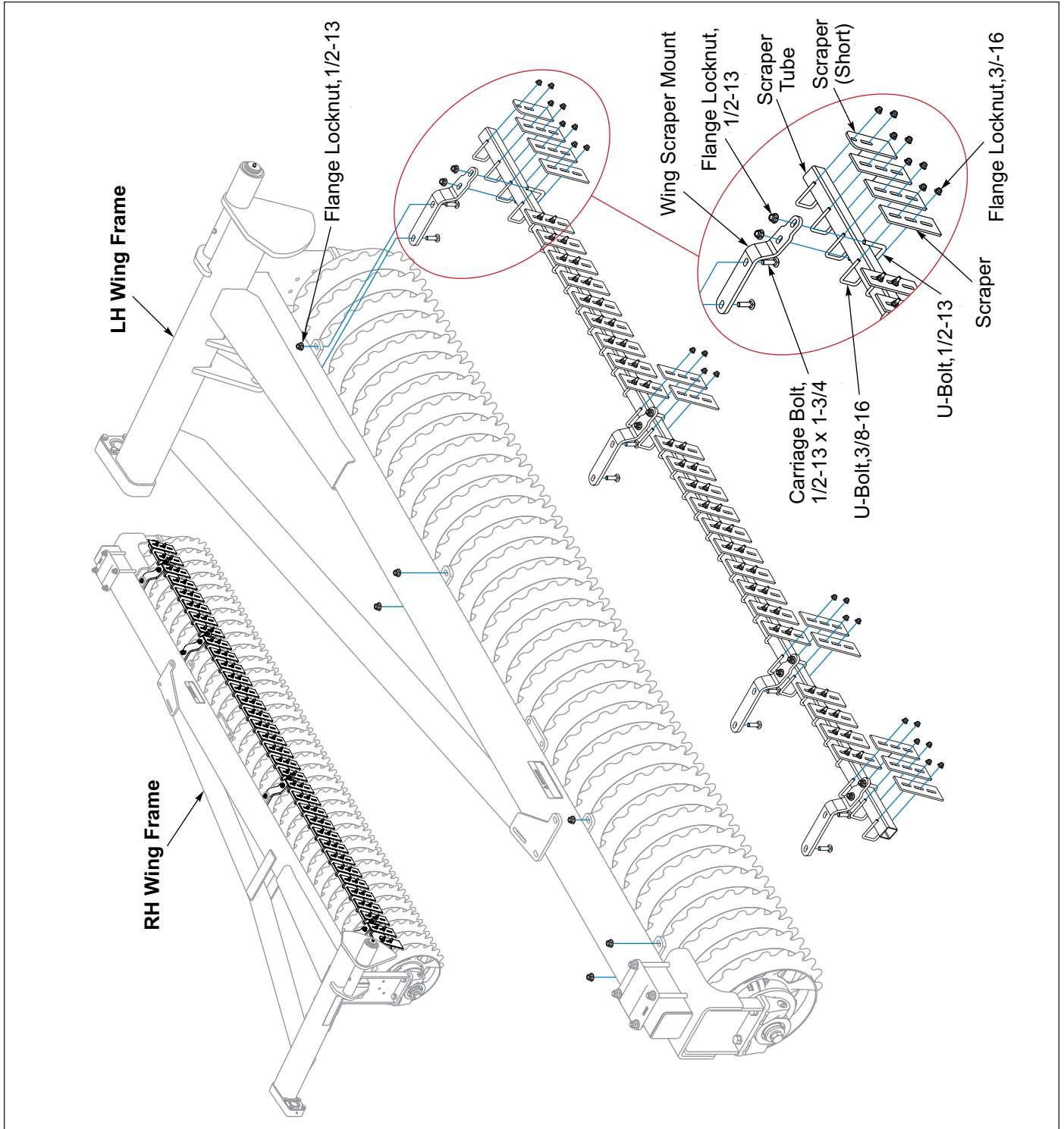

Figure 2-24: Wing Roller Scrapers - Optional

Acre Meter Installation - Optional

IMPORTANT

Unfold and lower machine prior to performing any steps.

1. Attach the Acre Meter Assembly to the front frame tube using 5/8-11 U-Bolt and Locknuts. **See Figure 2-26.** Attach the Acre Meter Switch to the Acre Meter Bracket using #8-32 x 1-1/4" Screws, Flat Washers, Lock Washers, and Locknuts. Attach the short pickup switch ground wire under one of the screw heads, removing paint under the wire connector to assure a good electrical ground connection. **Do not tighten at this time.** Set aside.
2. Remove the existing 1- 8 x 2-1/4 bolt, 1" Lock Washer and 3/8" Thick Washer from the roller end. Slide existing Lock Washer, a 3/8" Thick Washer, Magnet Wheel and existing 3/8" Thick Washer onto 1-8 x 3 bolt. Insert into end of roller and fully tighten.
3. Remove the existing Trunnion Bearing Bolts and Lock Washers from bearing hanger. Place the Acre Meter Bracket onto the bearing hanger and re-install existing Trunnion Bearing Bolts and Lock Washers. Fully tighten.

4. Adjust the Acre Meter Switch so the center line of magnet wheel and pickup switch are horizontally and vertically aligned with a maximum 1/8" between magnet wheel and pickup switch. Now firmly tighten all screws. **See Figure 2-25.**

NOTE

Alignment of pickup switch and magnet wheel is critical. Improper alignment will cause the acre counter to record acres erratically or not at all.

5. Route the wire from the acre meter across the front frame to the Acre Meter Switch and connect the mating plugs.
6. Secure harness to existing light harness with tie straps to prevent harness from rubbing or becoming entangled. Install hose clamp into 1/2" hole in the trunnion bearing plate with 3/8-16 x 1-1/4 bolt, flat washer and locknut and nut.

See Page 3-9 for Programming the Acre Meter.

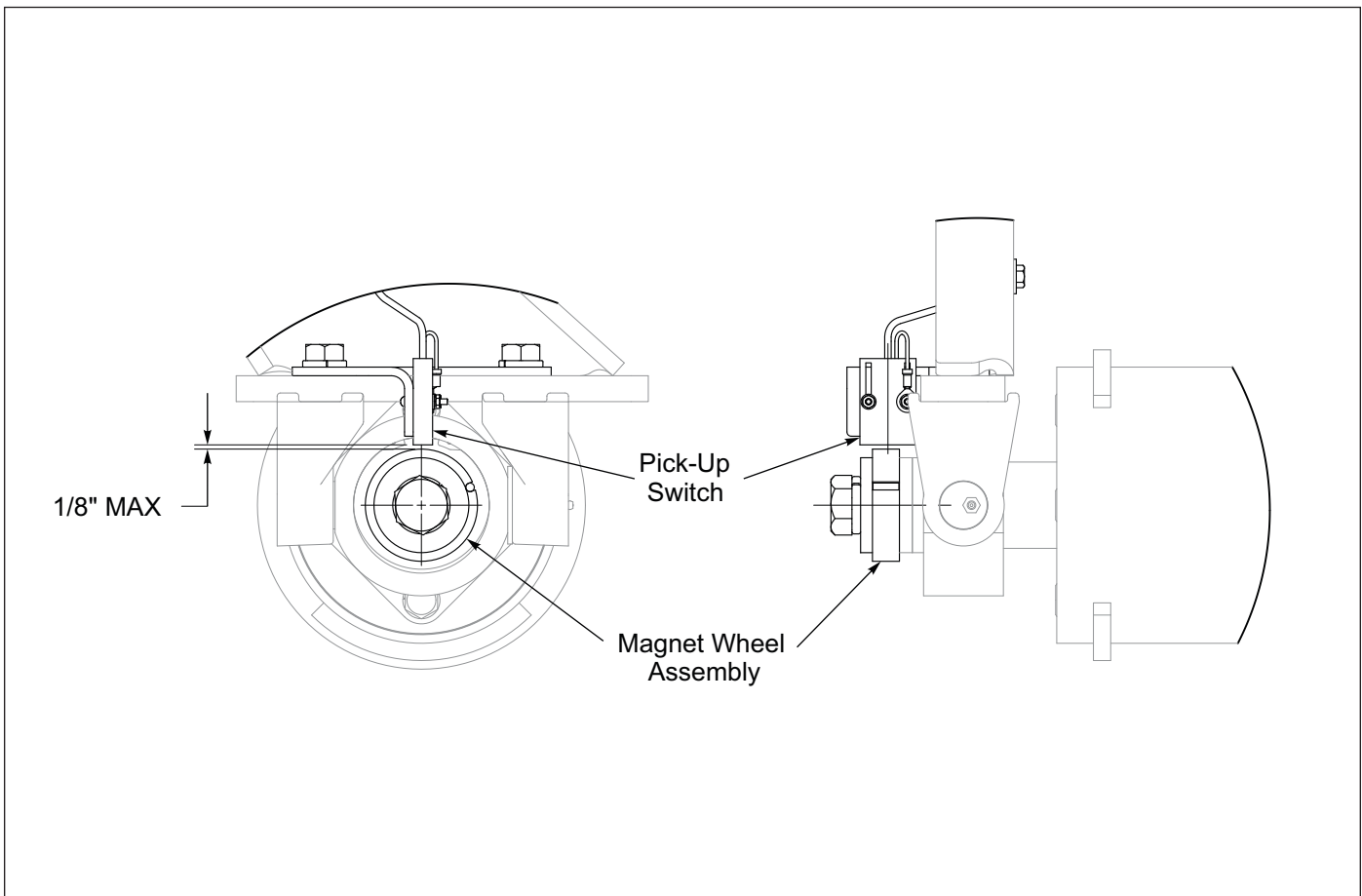

Figure 2-25: Acre Meter Switch Side View

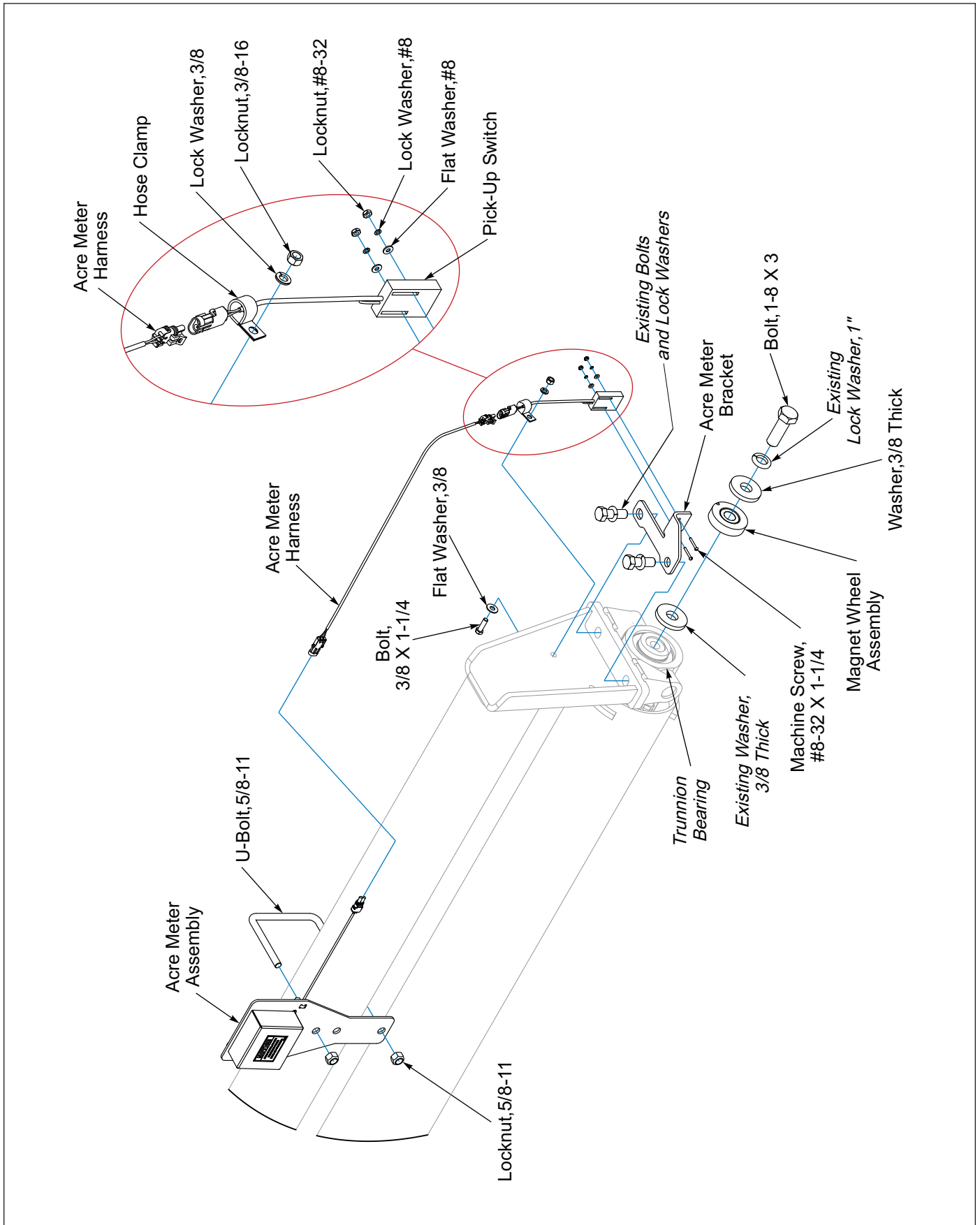

Figure 2-26: Acre Meter Installation - Optional

Float Lock Kit - Optional

Float Lock Kits prevents the Wings from floating which allows for the weight to transfer in softer field conditions.

1. Place Wing Float Stops into the Center Frame Yoke/Guide. **See Figure 2-27.**
2. Place a Wing Float Stop Plate on each side of the Wing Float Stops. Insert 3/8-16 x 3-1/2 Bolts from the inside outward.
3. Place Float Lock Spacers against the rear Wing Float Stop Plate. Secure with 3/8-16 Flange Locknuts.

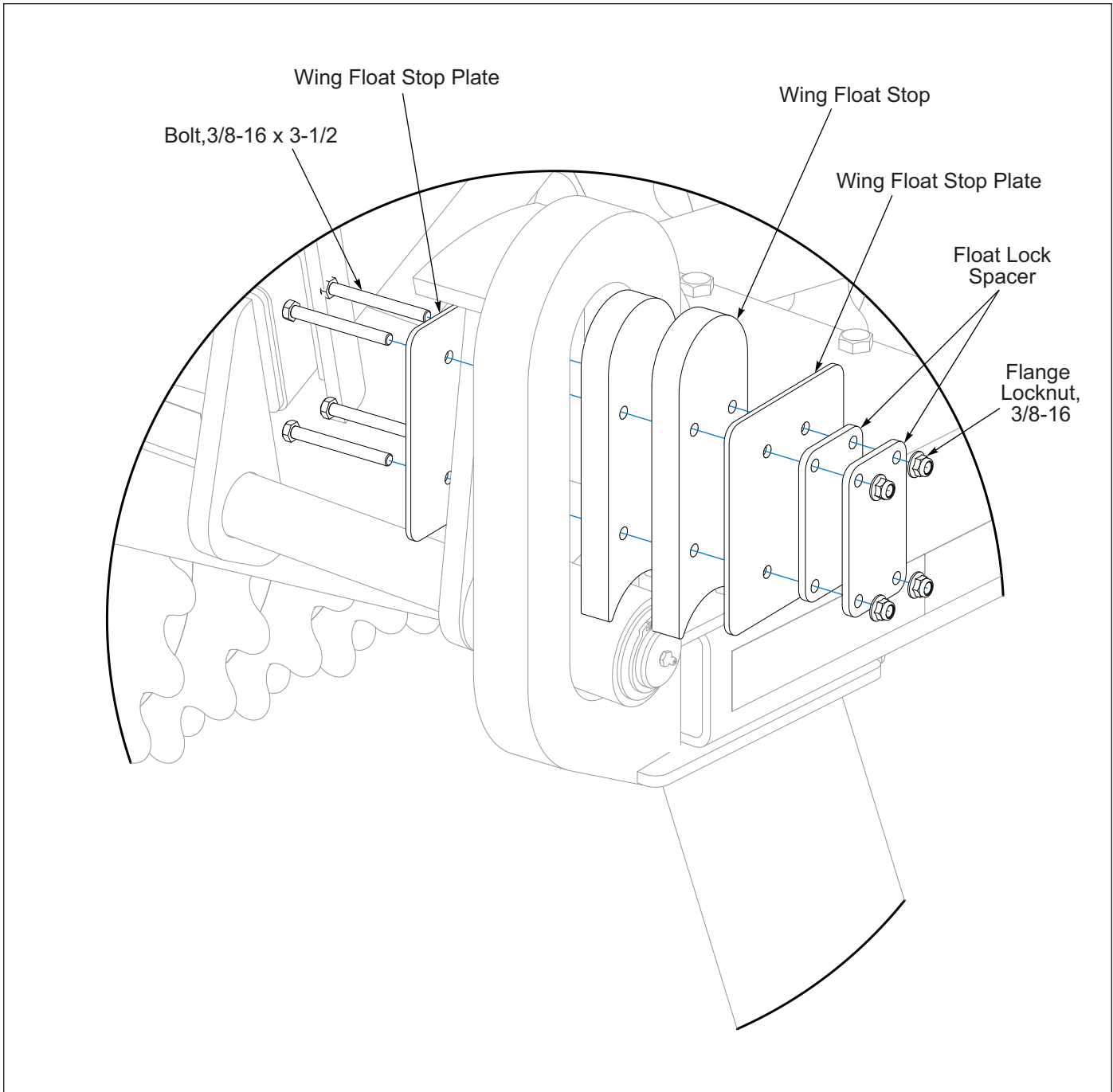

Figure 2-27: Float Lock Kit - Optional

Hydraulic Top Link Kit – Optional

The Hydraulic Top Link Kit replaces the Turnbuckle with a Hydraulic Cylinder. Use of the Hydraulic Top Link Kit reduces tongue weight in the transport position and increases the transport height 3".

Hydraulic Top Link Circuit requires approximately 1 gallon of hydraulic oil.

1. Carefully hitch the Pulverizer to the tractor and connect the Hydraulic Hoses. Check to make sure the tractor hydraulic reservoir is full of the manufacturer's recommended oil.
2. Unfold and lower machine. Reduce pressure on the Turnbuckle and remove.
3. Install Bolt-On Lug between Drawbar Lugs with 3/4-10 U-bolt and Locknuts. **See Figure 2-29.**
4. Attach 4 x 12 Hydraulic Cylinder base end to Bolt-On Lug with vendor supplied hardware. Block Cylinder Rod end up from the Drawbar to allow for rod movement when purging the Hydraulic Fold Link Circuit.
5. Install Elbow fittings into the Cylinder ports and attach the Hoses.
6. Install Adapters into the end of the Hoses and Male Couplers onto the Adapters.
7. Secure hoses to the Drawbar with Tie Wraps.

IMPORTANT

Unfold and lower the unit to the ground and relieve system pressure before attempting to repair, adjust, or disconnect components.



WARNING

Escaping fluid under pressure can be nearly invisible and have enough force to penetrate the skin causing serious injury. Use a piece of cardboard, rather than your hands, to search for suspected leaks. See Figure 2-28. Wear protective gloves & safety glasses or goggles when working with hydraulic systems. Keep all components (cylinders, hoses, fittings etc.) in good repair.

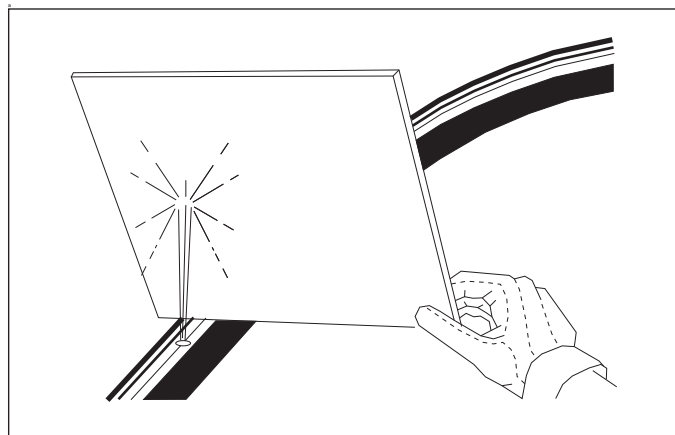

Figure 2-28: Hydraulic Leak Detection

8. Purge the Hydraulic Top Link Circuit. The hydraulic system is not filled with oil and should be purged of air before transporting and field operations.
9. With Hydraulic Top Link Cylinder Rod blocked up to allow for rod movement, completely extend the Hydraulic Top Link Cylinder. Recheck tractor oil reservoir. Extend and retract the Cylinder completely 5-6 times to purge air from the Hydraulic Circuit. Do not loosen hoses/fittings. Recheck tractor reservoir oil level.
10. After purging connect the Cylinder rod end with current Pin, Flat Washers and Roll Pins.

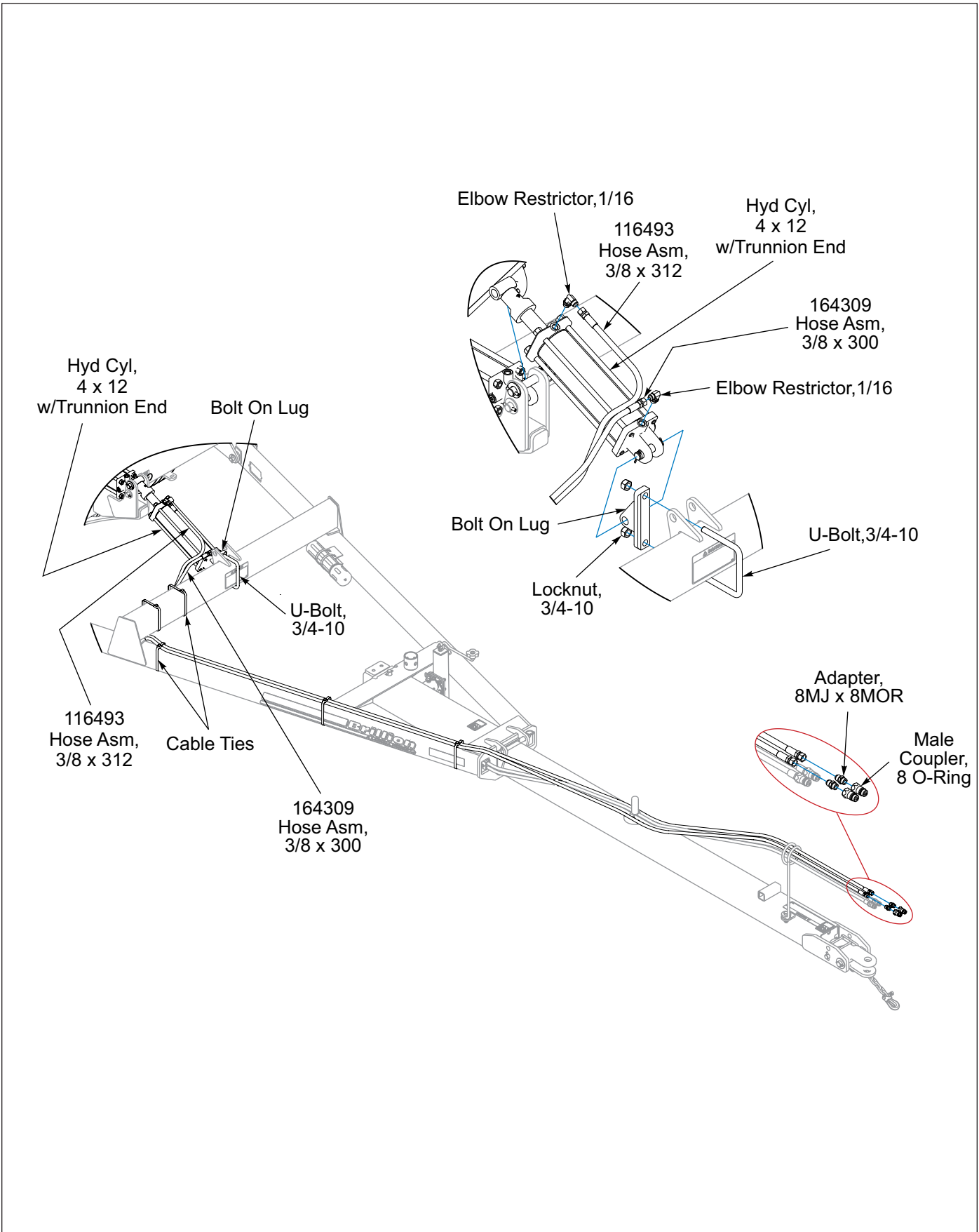

Figure 2-29: Hydraulic Top Link Kit - Optional

Operation

**DANGER**

Never allow anyone to ride on the Pulerizer at any time. Allowing a person to ride on the machine can inflict serious personal injury or death to that person.

**DANGER**

Always lock the tractor drawbar in the center position when transporting the unit. Failure to do so can result in serious injury or death and cause damage to the equipment.

**WARNING**

All hydraulically elevated equipment must have cylinder lockouts installed or be lowered to the ground, when servicing or when equipment is idle. Failure to take preventive measures against accidental lowering can result in serious personal injury.

**DANGER**

When transporting the unit, place cylinder lockouts in the transport lock position after fully extending the cylinders. Insert the lockout pins to secure the cylinder lockouts. Failure to lockout the cylinders can cause the unit to settle during transport, which can result in serious injury or death and cause damage to the equipment.

**CAUTION**

When transporting farm implements on public roads, it is the responsibility of the operator to abide by state and local laws concerning wide loads, speed, safety emblems and safety lighting equipment. Drive at safe speeds, particularly when rounding corners, crossing rough ground or driving on hillsides, to prevent tipping the tractor.

Tractor Preparation

The Brillion/Landoll Pulverizer is designed to be pulled by a tractor equipped with or without a hammer strap. **See Figure 1-2.**

Before attaching the implement, prepare the tractor as follows:

1. Inflate the rear tractor tires equally and add ballast according to the tractor operator's manual.
2. Lock the tractor drawbar in the center position.

Pulverizer Preparation

1. Prior to operating the Pulverizer, inspect it thoroughly for good operating condition.
2. Replace worn or missing parts.
3. When the machine is new, check the bolt tightness after a few hours of operation. Tighten any loose nuts or bolts. Check the lift wheel lug bolts daily.
4. Check the lift wheel tire inflation. Inflate all tires equally to avoid side draft. Follow the tire manufacturer's recommended pressures listed on the sidewall of the tires.



DANGER

Do not allow any bystanders to stand between the tractor and the implement while backing up to the implement.

Attaching to the Tractor

1. Align the tractor drawbar with the machine. Raise or lower the hitch as needed using the jack. Attach the unit with proper size hitch pin. **See Table 3-1.**
2. **Rigid Drawbar:** Always store Jack swung up and pinned, on the sleeve inside the A-Frame Tube before setting the machine in motion. If Jack is located on the Drawbar by the Hitch, move it to the sleeve on the inside the A-Frame Tube.

Telescoping Drawbar: Always store Jack pinned on the Sleeve on top of the Drawbar A-Frame before setting the machine in motion.
3. Clean all hydraulic couplings and attach to the tractor.
4. Fully extend the hydraulic lift cylinders, and retract the wing fold cylinders. Secure transport lock with hairpin cotters. **See Figure 3-6 and 3-7.**
5. Attach safety chain to tractor allowing plenty of movement for turning both directions. The safety chain should latch securely to prevent it coming loose. **See Figure 1-2.**

6. Plug the 7-Pin Connector to tractor outlet, routing cable by avoiding pinch points.
 - Make sure the tractor has a good clean receptacle, free of dirt and corrosion.
 - Make sure the 7-pin connector is inserted ALL the way in. With tighter fitting pins, operator may think the connector is all the way in, but really isn't.
 - Make sure the tractor receptacle cover latches over the keyway on the 7-pin connector to hold the connector in place.
 - If an operator plugs in the 7-pin connector, but the lights do not seem to work right, check the above items to make sure there is a good connection with the 7-pin connector.

DRAWBAR CAT	Min Pin Size	Max PTO HP
2	1-1/4" (30mm)	154 (115 Kw)
3	1-1/2" (38mm)	248 (185 Kw)

Table 3-1: Hitch Pin Size

Hitch Lock

The Hitch Lock prevents the hitch from moving in either the Spade or Clevis position. *Note the different orientation of the Hitch Lock.*

- **Spade position:** Insert the Hitch Lock into the clevis end opening. Secure the Hitch Lock with 1 x 9-1/4 Pin and 1/4 x 1-1/4 Lynch Pin. **See Figure 3-1.**
- **Clevis position:** Insert the spade end of the hitch into the Hitch Lock opening. Secure the Hitch Lock with 1 x 9-1/4 Pin and 1/4 x 1-1/4 Lynch Pin. **See Figure 3-2.**

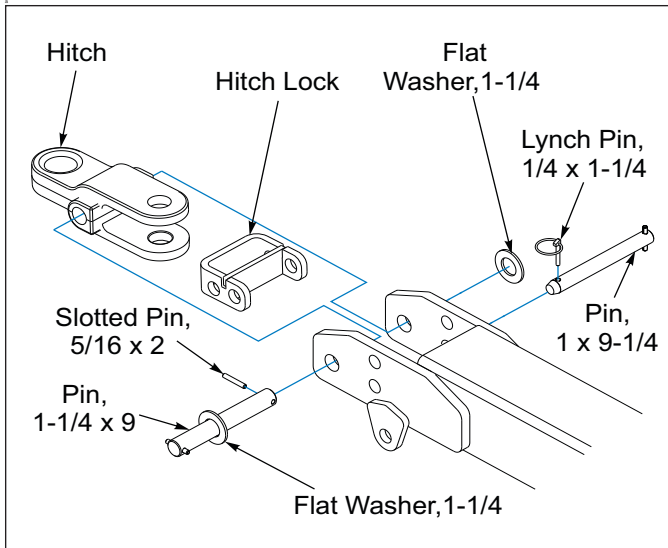

Figure 3-1: Spade Position

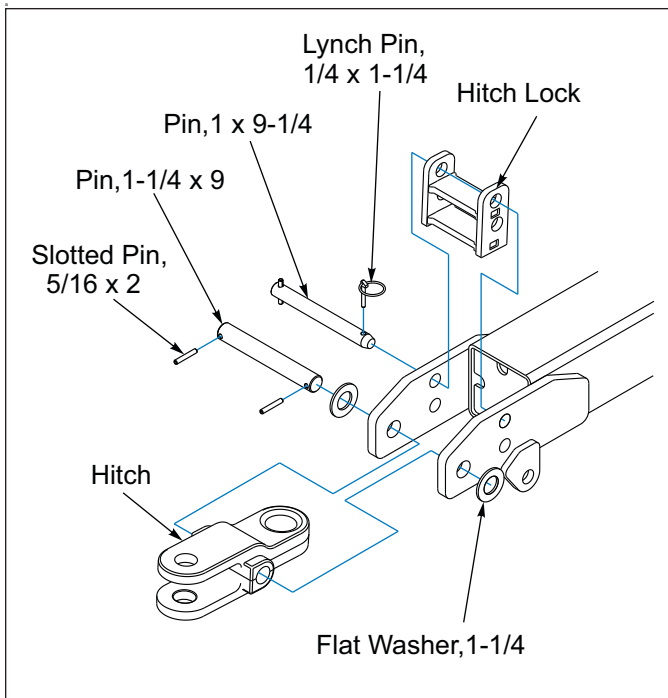

Figure 3-2: Clevis Position

Telescoping Drawbar

The Telescoping Drawbar is design to be operated with the Drawbar Extension retracted or extended. The Drawbar must be extended when used as a companion equipment.

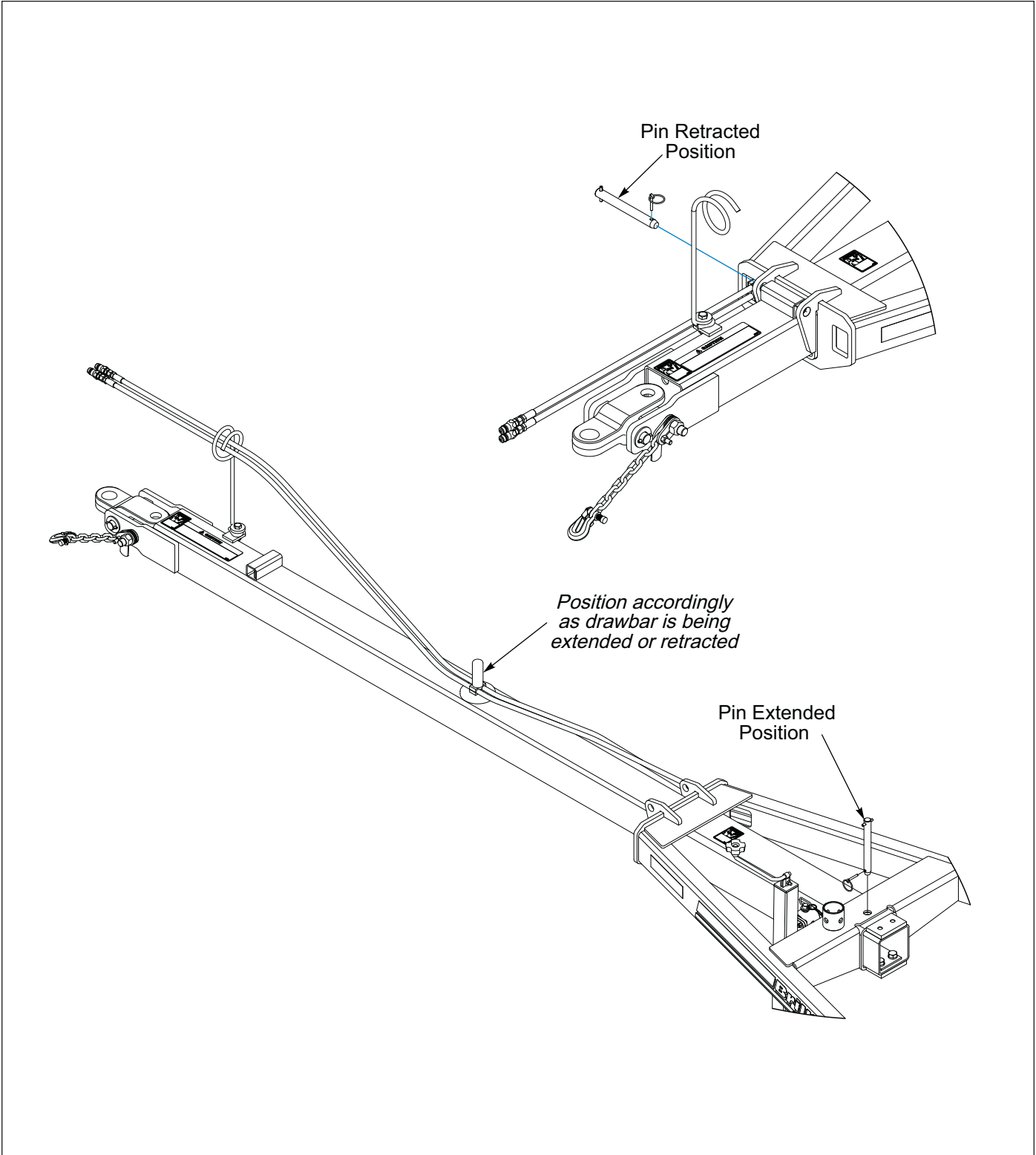

Figure 3-3: Telescoping Drawbar

Hydraulic System

IMPORTANT

Unfold and lower the unit to the ground and relieve system pressure before attempting to repair, adjust, or disconnect components.

The Pulverizer is equipped with a single hydraulic circuit that folds/unfolds the Wings and raises/lowers the machine.



WARNING

Escaping fluid under pressure can be nearly invisible and have enough force to penetrate the skin causing serious injury. Use a piece of cardboard, rather than your hands, to search for suspected leaks. See Figure 3-4. Wear protective gloves & safety glasses or goggles when working with hydraulic systems. Keep all components (cylinders, hoses, fittings etc.) in good repair.

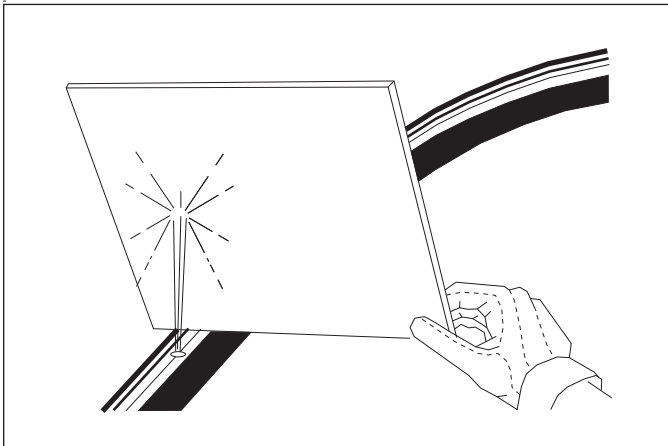

Figure 3-4: Hydraulic Leak Detection

Whenever folding/raising or unfolding/lowering the Pulverizer, find a level and large enough area to accommodate the machine when it is unfolded.

The wing fold cylinders are equipped with restrictors to prevent uncontrolled falling of wing frames when unfolding. Removal or improper assembly of these restrictors can cause the machine to fold improperly and result in serious machine damage.

Never unfold the wings past center until all air is out of the hydraulic circuit, as Free Falling may occur.

1. The hydraulic system is not factory filled with oil and should be purged of air before transporting and field operations. Carefully hitch the Pulverizer to the tractor and connect the hydraulic hoses.
2. Check to make sure the tractor hydraulic reservoir is full of the manufacturer's recommended oil.

3. On level ground, unfold the wings completely and lower machine to the ground. Make sure the Wing Cylinders are extended completely and the Transport Axle Cylinder is retracted. The Cylinders should be working smoothly through the stroke, if not purge the system. See "Purging the Hydraulic System" on page 2-18. Air in the system can allow uncontrolled dropping of the Wing Frames causing serious personal injury or machine damage. The system needs to be charged with oil initially and any time the system has been opened for repair such as cylinder, hose, or fitting replacement/repair.
4. Do not loosen hoses/fittings after the Hydraulic Circuit has been purged.
5. Recheck tractor reservoir oil level.

Hydraulic circuit requires approximately 4-1/2 to 6 gallons of hydraulic oil depending on the model.

General Operation

1. Horsepower requirements will vary due to speed, moisture, residue and types of soils. Local dealers can help in making recommendations for your conditions.
 - The minimum horsepower requirement as an Independent Tool is 3-5 horsepower per foot of rolling width.
 - The minimum horsepower requirement as a Companion Tool is 1-3 horsepower per foot of rolling width.
2. Operating speed is typically 5-8 mph. Reduce speed in rocky conditions to prevent wheel breakage.

3. Wings should always unfold first, then machine lowers. If not, reduce hydraulic fluid flow.
4. With machine unfolded and lowered on a level surface, adjust the Turnbuckle so that each Wing Roller is at the lower 1/3 of its respective Guide Slot. **See Figure 3-5.**
5. During field operation, it is not necessary to raise the machine for turns, but turns should be as wide as possible.



WARNING

Watch out for Overhead Electrical Wires and other Overhead Obstructions when folding and unfolding Pulverizer Wings.

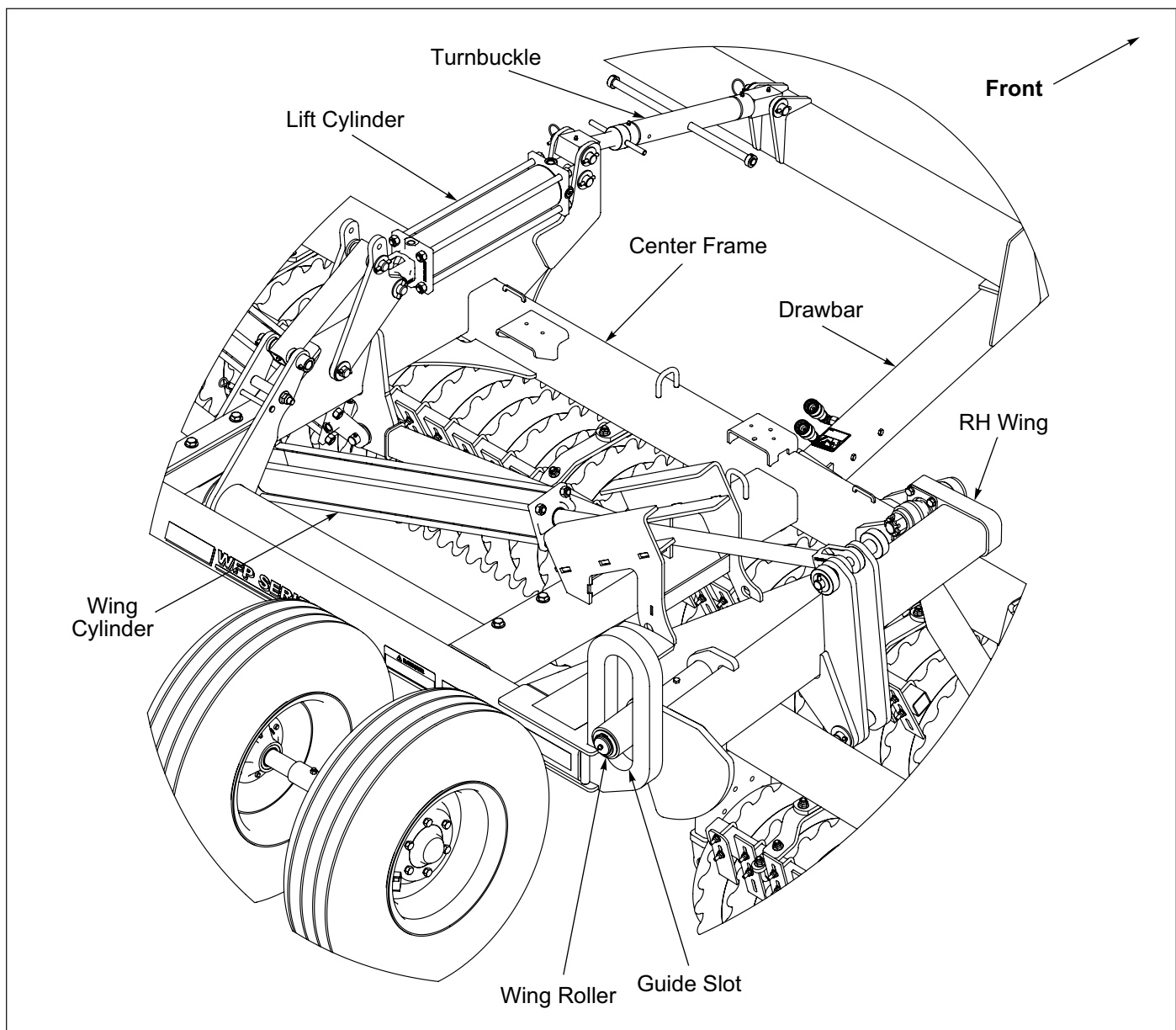

Figure 3-5: Wing Guide Slot

Transport Lock

Road to Field

1. Raise the machine fully. Wings should be folded.
2. Remove Hair Pin Cotter and 1/2 x 6 Clevis Pin that is used as the Transport Lock from the Toggle Links. **See Figure 3-6.**
3. Store the Clevis Pin in the Transport Axle Assembly Lugs. Secure with Hair Pin Cotter. **See Figure 3-7.**
4. Unfold Wings and Lower Pulverizer to the ground.

Field to Road

1. Fold Wings completely and raise the machine fully. Wing Cylinders retracted and Lift Cylinder extended.
2. Remove the stored 1/2 x 6 Clevis Pin and Hair Pin Cotter that will be used as the Transport Lock from the Transport Axle Assembly Lugs. **See Figure 3-7.**
3. Install the Clevis Pin in the Toggle Links. Secure with Hair Pin Cotter. **See Figure 3-6.**

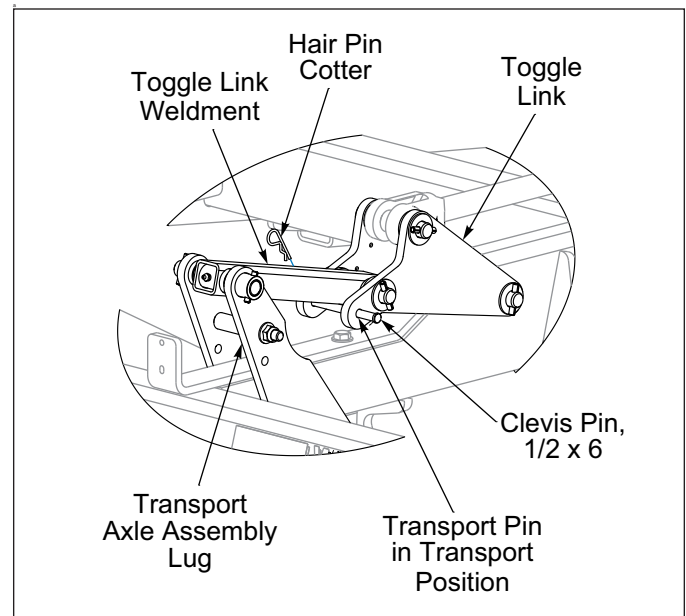

Figure 3-6: Transport Pin in Transport Position

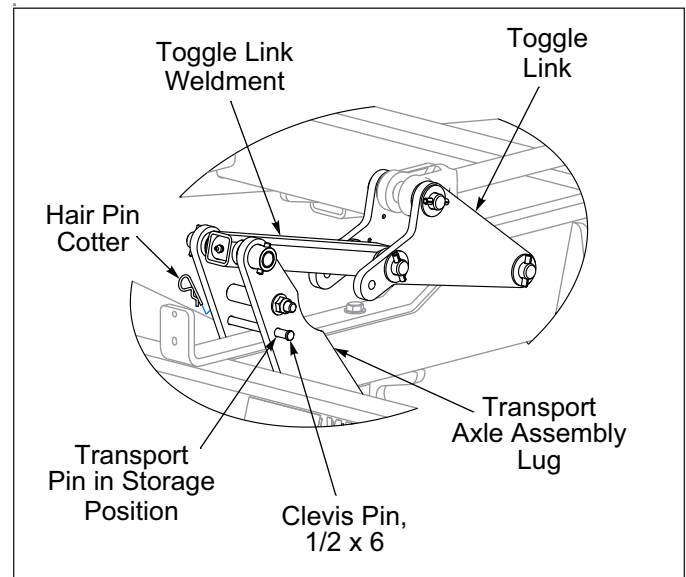

Figure 3-7: Transport Pin in Storage Position

Scraper Adjustment

NOTE

Notched Roller Wheel Scrapers are optional and reversible.

Notched Roller Wheel Scrapers are designed to keep the Notched Roller Wheels from building up with moist soil during operation. Adjustment of the Scrapers will be necessary as the Roller Wheels and/or the Scrapers wear.

1. Unfold and Lower Pulverizer on a level surface.
2. Push Notched Wheels against welded Roller Axle End Stops and add Clamp End Spacers if needed. See Fig 4-5 and 4-6.
3. Adjust Scrapers as needed to obtain a 1/4" gap between the Scraper and Notched Wheel. **See Figure 3-8.** Scrapers are 1/4" thick and can be used to set the 1/4" gap.

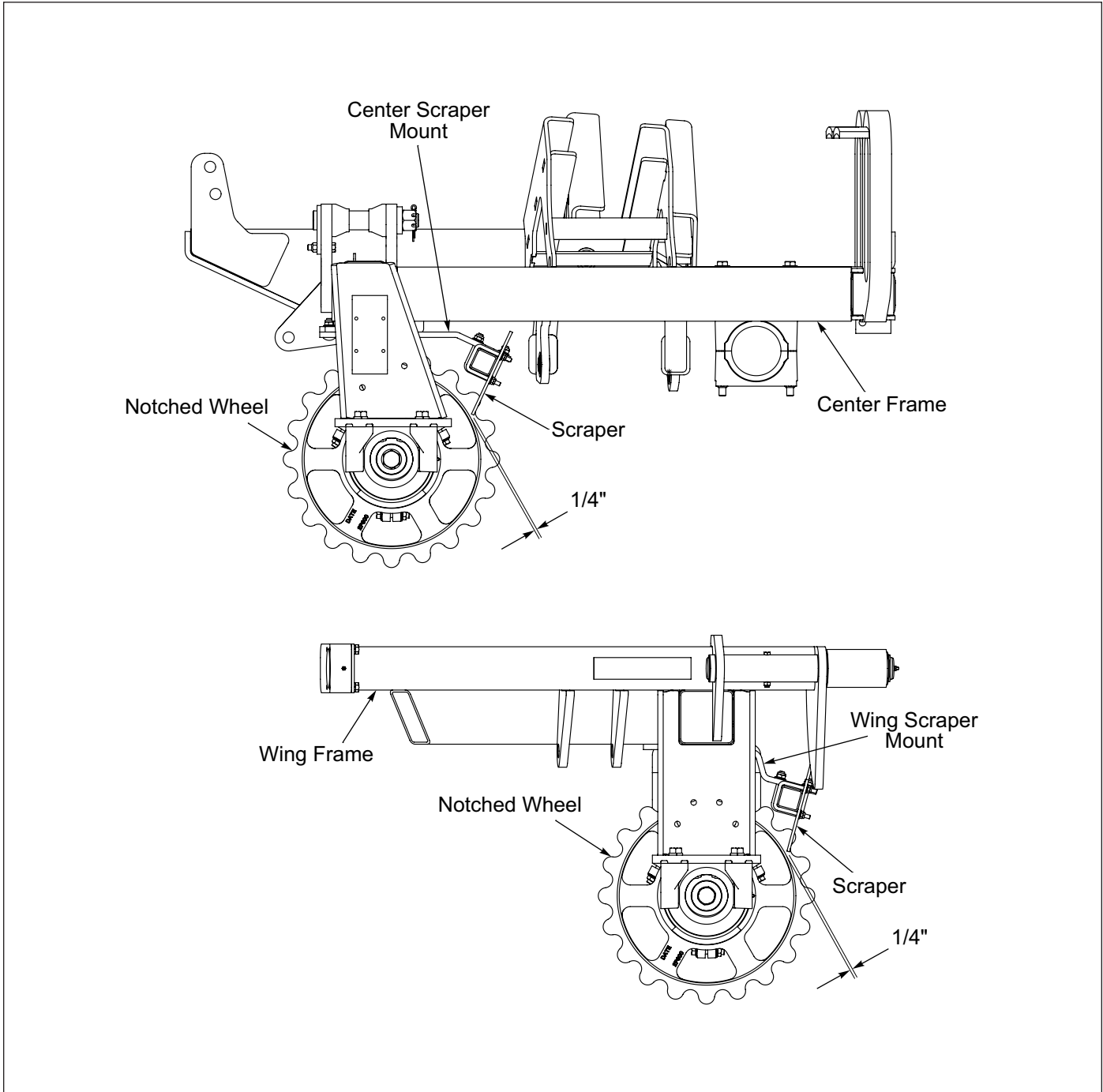

Figure 3-8: Scraper Adjustment

Electronic Acre Meter Kit

The battery operated acre counter operates in one of two modes. In sleep mode, the display is blank, and the counter is accumulating acres. Sleep mode will be entered if a button is not pressed for 20 seconds. In entry mode, the display is on, and the operator can enter values. To get into entry mode, press the ***/FUNC** button. If you continue to press the ***/FUNC** button, the acre counter will cycle through the functions that it can perform. The LEDs above the display indicate which function is selected.

The available functions are:

Field Acres, Total Acres, Pulses per 400 ft, Width, Password and Low Battery

Field Acres

Press the ***/FUNC** button until the “**FIELD**” LED is lit. The digits indicate the acres covered since the field acre counter was cleared.

To clear the field acre count, press the **UP** and **DOWN** buttons simultaneously for two seconds. If a password has been entered, you will not be able to clear the total acre count. Field acres will count in tenths of an acre up to 9999.9 acres.

Total Acres

Press the ***/FUNC** button until the “**FIELD**” and “**TOTAL**” LEDs are lit. The digits indicate the acres covered since the total acre counter was cleared.

To clear the total acre count, press and hold the **UP** and **DOWN** buttons for two seconds. If a password has been entered, you will not be able to clear the total acre count.

Total acres will count from .1 to 99999 acres.

Pulses Per 400 Feet

Press the ***/FUNC** button until the “**PULSES**” LED is lit. The number in the display indicates how many pulses are generated for every 400 feet driven. There are two methods to enter the pulses per 400 feet:

If you know the number, select it using the **UP** and **DOWN** buttons. When you press the ***/FUNC** button, the Acre Counter will accept the number in the display as the new pulses per 400 feet. **See Table 3-2.**

If you do not know the pulses per mile, press and hold the **UP** and **DOWN** buttons until the “0000” appears in the display. The “**PULSES**” LED will blink. The acre counter is now counting shaft rotations. Enter the cab and drive 400 feet.

Press the ***/FUNC** button to wake up the acre counter. The “**PULSES**” LED will again blink. The number displayed is the pulses per 400 feet. Press the ***/FUNC** button to accept the setting. The “**PULSES**” LED will stop blinking and remain on.

If a password is set, you will not be able to adjust the pulses 400 feet.

Width

Press the ***/FUNC** button until the “**WIDTH**” LED is lit. The number displayed is the length of your implement in feet.

To adjust the width, press the **UP** and **DOWN** buttons. If a password has been entered, you will not be able to adjust the width.

The length can be adjusted from .1 to 99.9 feet, in tenths of a foot.

Password

The password function allows you to protect the total acre count, pulses per 400 feet, and width settings with a password. This stops anyone from accidentally changing those settings. When the acre counter is shipped, the password is disabled. You can modify the pulses per 400 feet and implement width at any time.

Press the ***/FUNC** button until the “**PASS**” LED is lit. The digits will display the word “**Ent**” or “**dis**”.

If the display shows “**dis**”: The password is disabled. The total acre count, pulses/400 ft, width, and password settings can be adjusted using the **UP** and **DOWN** buttons. The password can also be changed using the **UP** and **DOWN** buttons.

If the display shows “**Ent**”: You must enter your password using the **UP** and **DOWN** buttons. When your password is displayed, press the ***/FUNC** button to test the password.

If the password is correct, you will be able to change the acre counter settings. The password will be viewable until the acre counter powers down. When the acre counter is powered up again, you will have to re-enter the password to change settings.

If the password is not correct, you will not be able to change the acre counter settings. When the “**PASS**” function is selected again, “**Ent**” will appear in the display.

Changing the Acre Meter Password

Select a new password using the **UP** and **DOWN** buttons. Press the ***/FUNC** button until the word “**SET**” appears in the display. Release the ***/FUNC** button. The number in the display is your new pass code. Make sure you record this number. Press and hold the ***/FUNC** button until the word “**dis**” appears in the display.

If the password is forgotten, it can be disabled by removing the batteries. The password is intended for rental units. It is recommended that a seal be affixed to the rear plate of the acre counter to determine if the settings have been tampered with.

TABLE OF CONTENTS

MODEL				Pulses per 400 FT	Width (Feet)
SSPT604				22	5.0
SSP4	SS4			44	4.0
SSP5				44	5.0
SSP6				44	6.0
SSP8	SSBP8	SS8	SSB8	58	8.0
SSP10	SSBP10	SS10	SSB10	58	10.0
SSP12	SSBP12	SS12	SSB12	58	12.0
SSP16		SS16		45	16.0
SSP108	SS108			58	8.0
SSP110	SS110			58	10.0
SSP112	SS112			58	12.0
SSP208/2081	SS208/2081			58	8.0
SSP210/2101	SS210/2101			58	10.0
SSP212/2121	SS212/2121			58	12.0
SSP308/3081	SS308/3081			29	8.0
SSP310/3101	SS310/3101			29	10.0
SSP312/3121	SS312/3121			29	12.0
SLP8	SL8			314	8.0
SLP10	SL10			314	10.0
SLP12	SL12			314	12.0
SLP204/2041	SLPB204/2041			128	4.0
SLP206/2061	SLPB206/2061			128	6.0
SLP304/3041	SLPB304/3041			64	4.0
SLP306/3061	SLPB306/3061			64	6.0
LSP5				128	5.0
LSP6				128	6.0
LSS6				128	6.0
SLP208/2081	SLPB208/2081	SL208/2081	SLB208/2081	116	8.0
SLP210/2101	SLPB210/2101	SL210/2101	SLB210/2101	116	10.0
SLP212/2121	SLPB212/2121	SL212/2121	SLB212/2121	116	12.0
SLP308/3081	SLPB308/3081	SL308/3081	SLB308/3081	58	8.0
SLP310/3101	SLPB310/3101	SL310/3101	SLB310/3101	58	10.0
SLP312/3121	SLPB312/3121	SL312/3121	SLB312/3121	58	12.0
BOS4F1	BOS4S1	BOSB4F1	BOSB4S1	45	4.0
BOS6F1	BOS6S1	BOSB6F1	BOSB6S1	45	6.0
BPS6	BPSB6			51	6.0
GLP643	SSLP643			69	5.0
4620-24				45	24.0
4630-36				per Seeder	36.0
X19-27	XL28-36	XXL38-46		90	per Model
WFP23-37				90	per Model

Table 3-2: Acre Meter Settings

Transporting on a Trailer

Rigid and Telescoping Drawbars can be removed when transporting the Wing Float Pulverizer on a trailer.

1. With the Wing Float Pulverizer fully raised and wings folded, close the Fold Shut-off Valve completely. **See Figure 3-9.**
2. Lower the machine onto the Roller Wheels.
3. Disconnect Drawbar from tractor.
4. Retract Telescoping Drawbar if equipped.
5. Disconnect (Quick Coupling) Hydraulic Hoses and the Ag Harness where the frame connects to the Drawbar.
6. Remove Turnbuckle and the Drawbar Pins.

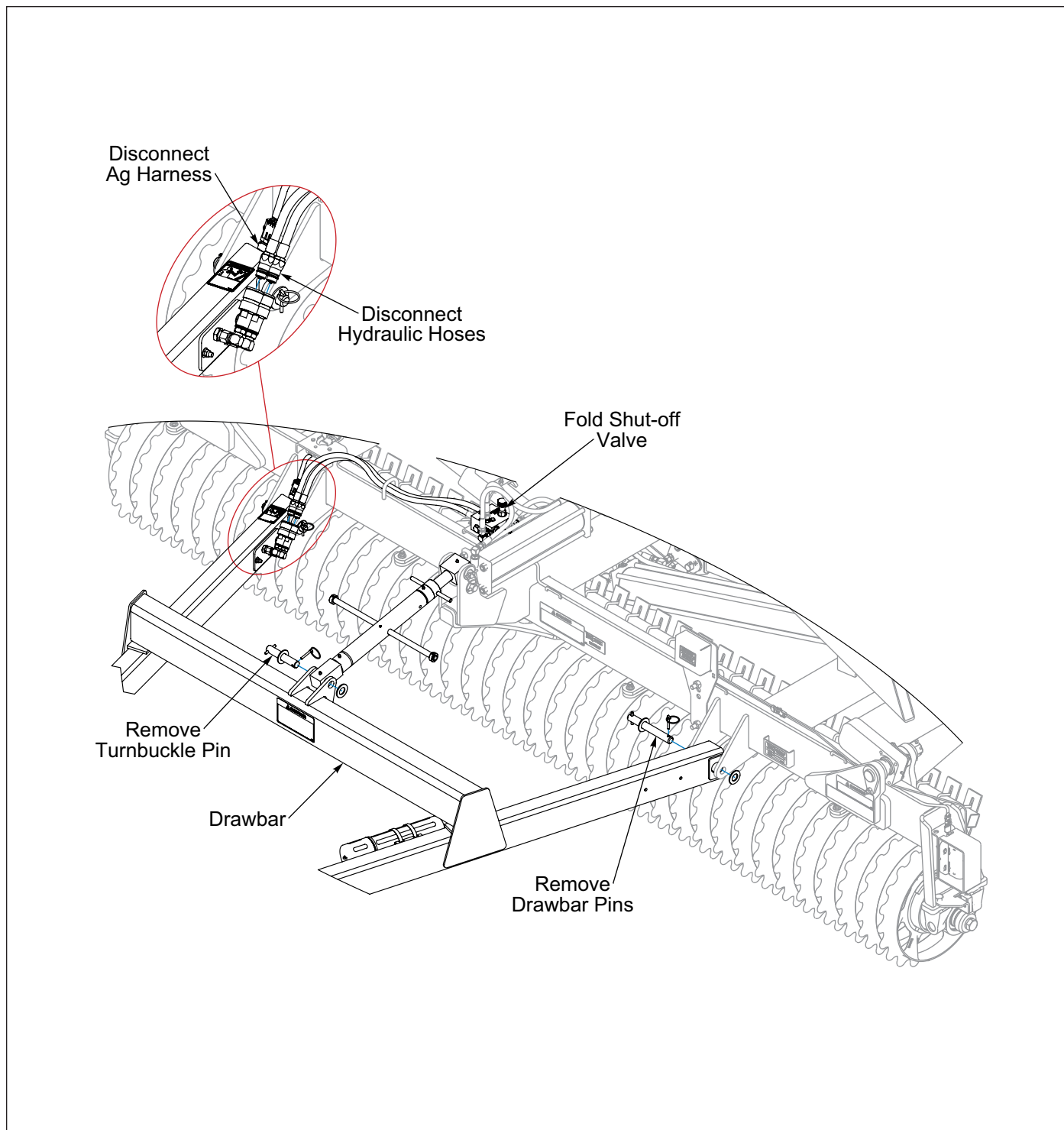

Figure 3-9: Drawbar Removal

Transport

1. Check and follow all federal, state, and local requirements before transporting the Pulverizer.
2. The Pulverizer should be transported only by tractor required for field operation. The implement weight should not exceed more than 1.5 times the tractor weight. Maximum transport speed for the Pulverizer is 20 mph for the implement.



CAUTION

Excessive speed may result in loss of control of the tractor and implement, reduced braking ability, or failure of the implement tire or structure. Do not exceed the implement maximum specified ground speed regardless of the capability of the maximum tractor speed.

3. When towing equipment in combination, the maximum equipment ground speed shall be limited to the lowest specified ground speed of any of the towed implements.

Maximum transport speed shall be the lesser of travel speed specified in the operator's manual, speed identification symbol, information sign of towed equipment, or limit of road conditions.

- **EXAMPLE:** If the tractor is capable of 25 mph, the first implement has a SIS for 19 mph, and the last implement's operator's manual states its specified ground speed is 15 mph, the towed equipment combination ground speed limitation is 15 mph.

4. Slow down when driving on rough roads. Reduce speed when turning, or on curves and slopes to avoid tipping. Equipment altered other than the place of manufacture may reduce the maximum transport speed. Additional weight, added tanks, harrowing attachments, etc. may reduce implement load carrying capabilities.
5. A safety chain is provided with the implement to insure safe transport. **See Figure 1-2.**
 - The safety chain should have a tensile strength equal to or greater than the gross weight of the implement. The chain is attached to the lower hitch clevis hole with two flat washers between the clamp plates to assure a tight connection. Always use a 1" diameter Grade 8 bolt for this connection.
 - Attach the safety chain to the tractor drawbar. Provide only enough slack in the chain for turning. Do not use an intermediate chain support as the attaching point for the chain on the tractor. Do not pull the implement by the safety chain.

- Regularly inspect the safety chain for worn, stretched, or broken links and ends. Replace the safety chain if it is damaged or deformed in any way.
6. Check that tires are of proper size, load rating, and inflated to manufacture specifications before transporting. Check wheel lug bolts to ensure tightness.
 7. Know the transport heights and widths of the unit before transporting. Use caution when transporting near bridges and power lines.



WARNING

Electrocution can occur without direct contact.

8. Raise the machine to full transport height.
9. Install transport lock. Do not depend solely on implement hydraulics for transport. **See Figures 3-6 and 3-7.**



WARNING

Failure to use transport lock pins during transport may result in permanent equipment damage, serious injury or death.

10. Transport during daylight hours when ever possible. Always use flashing warning lights, except where such use is prohibited by law. Make sure lights, reflectors and SMV emblem are clearly visible and operating. remove any obstructions such as dirt, mud, stalks or residue that restricts view before transporting.

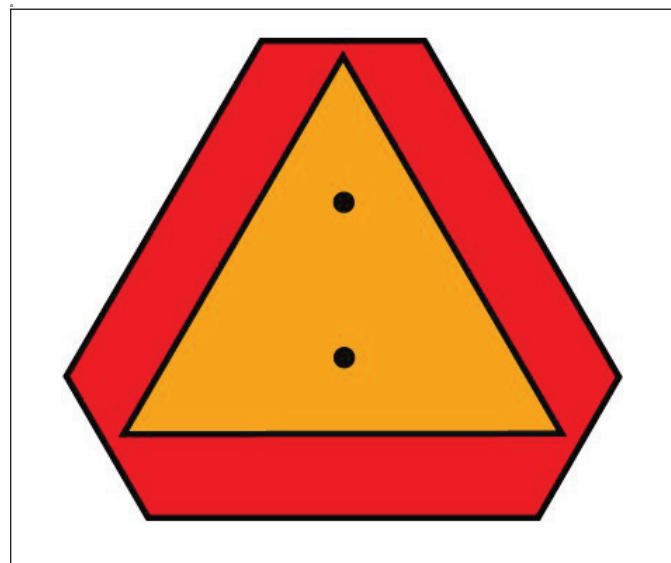

Figure 3-10: SMV Sign

General Torque Specifications

(rev. 4/97)

This chart provides tightening torques for general purpose applications when special torques are not specified on process or drawing. Assembly torques apply to plated nuts and capscrews assembled without supplemental lubrication (as received condition). They do not apply if special graphite moly-disulfide or other extreme pressure lubricants are used. When fasteners are dry (solvent cleaned) add 33% to as received condition torque. Bolt head identification marks indicate grade and may vary from manufacturer to manufacturer. Thick nuts must be used on grade 8 capscrews. Use value in [] if using prevailing torque nuts

TORQUE SPECIFIED IN FOOT POUNDS

UNC SIZE	SAE Grade 2	SAE Grade 5	SAE Grade 8	UNC SIZE	SAE Grade 2	SAE Grade 5	SAE Grade 8
1/4-20	4 [5]	6 [7]	9 [11]	1/4-28	5 [6]	7 [9]	10 [12]
5/16-18	8 [10]	13 [13]	18 [22]	5/16-24	9 [11]	14 [17]	20 [25]
3/8-16	15 [19]	23 [29]	35 [42]	3/8-24	17 [21]	25 [31]	35 [44]
7/16-14	24 [30]	35 [43]	55 [62]	7/16-20	27 [34]	40 [50]	60 [75]
1/2-13	35 [43]	55 [62]	80 [100]	1/2-20	40 [50]	65 [81]	90 [112]
9/16-12	55 [62]	80 [100]	110 [137]	9/16-18	60 [75]	90 [112]	130 [162]
5/8-11	75 [94]	110 [137]	170 [212]	5/8-18	85 [106]	130 [162]	180 [225]
3/4-10	130 [162]	200 [250]	280 [350]	3/4-16	150 [188]	220 [275]	320 [400]
7/8-9	125 [156]	320 [400]	460 [575]	7/8-14	140 [175]	360 [450]	500 [625]
1-8	190 [237]	408 [506]	680 [850]	1-14	210 [263]	540 [675]	760 [950]
1-1/8-7	270 [337]	600 [750]	960 [1200]	1-1/8-12	300 [375]	660 [825]	1080 [1350]
1-1/4-7	380 [475]	840 [1050]	1426 [1782]	1-1/4-12	420 [525]	920 [1150]	1500 [1875]
1-3/8-6	490 [612]	1010 [1375]	1780 [2225]	1-3/8-12	560 [700]	1260 [1575]	2010 [2512]
1-1/2-6	650 [812]	1460 [1825]	2360 [2950]	1-1/2-12	730 [912]	1640 [2050]	2660 [3325]

METRIC:

Coarse thread metric class 10.9 fasteners and class 10.0 nuts and through hardened flat washers, phosphate coated, Rockwell "C" 38-45. Use value in [] if using prevailing torque nuts

Nominal thread diameter (mm)	Newton Meters (Standard Torque)	Foot Pounds (Standard Torque)	Nominal Thread Diameter (mm)	Newton Meters (Standard Torque)	Foot Pounds (Standard Torque)
6	10 [14]	7 [10]	20	385 [450]	290 [335]
7	16 [22]	12 [16]	24	670 [775]	500 [625]
8	23 [32]	17 [24]	27	980 [1105]	730 [825]
10	46 [60]	34 [47]	30	1330 [1470]	990 [1090]
12	80 [125]	60 [75]	33	1790 [1950]	1340 [1450]
14	125 [155]	90 [115]	36	2325 [2515]	1730 [1870]
16	200 [240]	150 [180]	39	3010 [3210]	2240 [2380]
18	275 [330]	205 [245]			

Hydraulic Fitting Torque Specifications

37 degree JIC, ORS, &ORB (REV. 10/97)

This chart provides tightening torques for general purpose applications when special torques are not specified on process or drawing. Assembly torques apply to plated nuts and capscrews assembled without supplemental lubrication (as received condition). They do not apply if special graphite moly-disulfide or other extreme pressure lubricants are used. When fasteners are dry (solvent cleaned) add 33% to as received condition torque. Bolt head identification marks indicate grade and may vary from manufacturer to manufacturer. Thick nuts must be used on grade 8 capscrews. Use value in [] if using prevailing torque nuts.

TORQUE SPECIFIED IN FOOT POUNDS

PARKER® BRAND FITTINGS

Dash Size	37 Deg. JIC	O-ring (ORS)	O-ring boss
-4	11-13	15-17	13-15
-5	14-16	-----	21-23
-6	20-22	34-36	25-29
-8	43-47	58-62	40-44
-10	55-65	100-110	58-62
-12	80-90	134-146	75-85
-16	115-125	202-218	109-121
-20	160-180	248-272	213-237
-24	185-215	303-327	238-262
-32	250-290	-----	310-340

GATES® BRAND FITTINGS

Dash Size	37 Deg. JIC	O-ring (ORS)	O-ring boss
-4	10-11	10-12	14-16
-5	13-15	-----	-----
-6	17-19	18-20	24-26
-8	34-38	32-40	37-44
-10	50-56	46-56	50-60
-12	70-78	65-80	75-83
-14	-----	65-80	-----
-16	94-104	92-105	111-125
-20	124-138	125-140	133-152
-24	156-173	150-180	156-184
-32	219-243	-----	-----

AEROQUIP® BRAND FITTINGS

Dash Size	37 Deg. JIC	O-ring (ORS)	O-ring boss
-4	11-12	10-12	14-16
-5	15-16	-----	16-20
-6	18-20	18-20	24-26
-8	38-42	32-35	50-60
-10	57-62	46-50	75-80
-12	79-87	65-70	125-135
-14	-----	-----	160-180
-16	108-113	92-100	200-220
-20	127-133	125-140	210-280
-24	158-167	150-165	270-360

Valve Torque Values

Part Number	Description	Torque (Ft-Lbs)
175159	Relief	24-26
171000	Shutoff	19-21

Fasteners

Before operating your Brillion machine, check all hardware for tightness. Use the Tightening Torque Table as a guide. **See Page 4-1.**

After a few hours of use, check entire machine and tighten any loose nuts or bolts. Daily or periodic checks should be made thereafter.

When replacing bolts, be sure to use fasteners of equal grade.

Tires

Recommended Tire Size: 11L x 15, 12Ply Implement Rib Rating

Tire Inflation Pressure: 52 PSI

When Re-Installing the 1/2-20 x 1 Wheel Bolts tighten to 50 Ft-Lbs. using the sequence in **See Figure 4-1**. Then tighten to full torque of 85-90 ft-lbs.

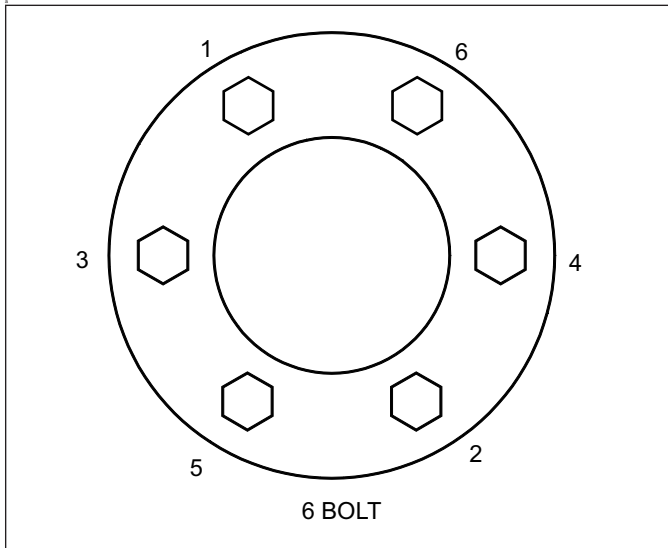

Figure 4-1: 6 Bolt Tightening Sequence

9. Tighten the Slotted Nut while rotating the Hub until there is a slight resistance to wheel rotation. Then, back the Slotted Nut off one notch, until the wheel rotates freely without end play.
10. Slide the Double Lip Seal to the Hub and install the Seal in the Hub.
11. Install a new Cotter Pin and re-install the Hub Cap.
12. Grease Wheels Hubs every 50 hrs.

Wheel Hub Bearing Maintenance

Wheel Bearing maintenance should be performed at the beginning of every season of use. Check the Wheel Bearings periodically for excessive end play. If needed, adjust or replace them using the following procedure:

1. Place the Frame on blocks or stands sufficient to lift the Tire clear of the ground.
2. Remove the Tire.
3. Remove the Hub Cap, Cotter Pin, Slotted Nut and Washer.
4. Remove the Hub. Clean and inspect the Bearings and Hub Cavity. Replace any worn or defective parts.
5. Repack the Bearings using a high-quality Wheel Bearing Grease.
6. Slide the Double Lip Seal onto the Spindle. Do not install the Seal into the Hub.

NOTE

The Double Lip Seals should point away from the Hub to keep contaminants out and allow grease to pass.

7. Slide the Inner Bearing Cone and Hub onto the Spindle.
8. Install the Outer Bearing Cone, Washer and Slotted Nut.

Lubrication Maintenance

CAUTION

Over lubrication of these bearings can cause premature bearing failure.

Greaseable components are the same on each side.

Lubricate with quality grease or if machine is not used for an extended period. **See Figure 4-2.**

- Every 20 hours lubricate Trunnion Bearings, Spherical Bearings, Hinge Pins and Toggle Link Weldment.
- Every 50 hours lubricate Wheel Hubs and Turnbuckle.
- Repack Wheel Hub bearings annually before each season usage.

When the machine is not used for some time, exposed portions of the hydraulic cylinder rods must be cleaned and covered with a thick coat of grease to prevent corrosion, which will damage the seal.

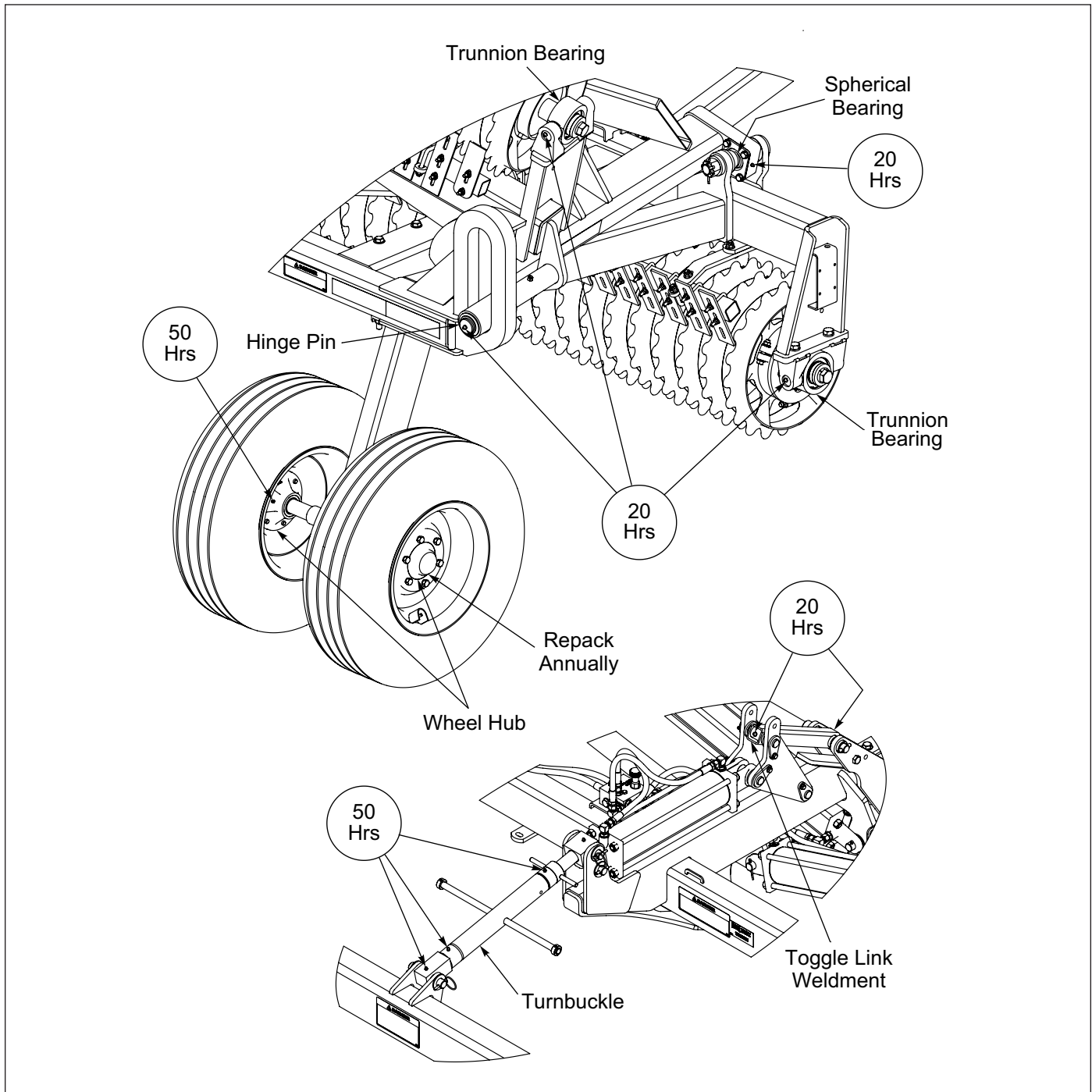

Figure 4-2: Lubrication Points and Intervals

Hydraulic System

IMPORTANT

Unfold and lower the unit to the ground and relieve system pressure before attempting to repair, adjust, or disconnect components.



WARNING

Escaping fluid under pressure can be nearly invisible and have enough force to penetrate the skin causing serious injury. Use a piece of cardboard, rather than your hands, to search for suspected leaks. See Figure 4-3. Wear protective gloves & safety glasses or goggles when working with hydraulic systems. Keep all components (cylinders, hoses, fittings etc.) in good repair.



Figure 4-3: Hydraulic Leak Detection

1. Check the tractor hydraulic fluid level per tractor owner's manual and after any leakage. Check fluid level with the cylinders in the retracted position.
2. If a cylinder or valve leaks, disassemble the parts to determine the cause of the leak. Any time a cylinder is opened up, or whenever any seal replacement is necessary, it is advisable to clean all parts and replace all seals. Seal kits are available from your Landoll dealer.
3. Check all hydraulic hoses weekly. Look for binding or cracking. Replace all worn or defective parts immediately.

4. Transport lock pin is provided to hold the implement in a raised position. **See Figure 3-6.** Do not attempt to perform any service work under the implement without first installing the transport lock pin. Before servicing any hydraulic component, unfold and lower the implement to the ground and relieve all system pressure. If a hydraulic component is disconnected, repaired, or replaced, it will be necessary to purge the system of air before operation. **See "Purging Hydraulic System" on page 4-6.**

Purging Hydraulic System

NOTE

Never unfold the wings past center until all air is out of the hydraulic circuit, as Free Falling may occur.



CAUTION

The wings depend upon the passage of oil through a flow restrictor to keep from falling. If the cylinder is not full of oil the wing will drop and may cause damage to the machine.



DANGER

Bleed the air from wing lift cylinders before operating. Failure to do so will allow wings to free-fall and may cause serious personal injury.

The first time the machine is connected to the tractor, or any time the hydraulic circuit is opened, air must be purged from the system. Care must be taken not to raise the wings up over center before they have been run part way up 7 or 8 times. The wings depend upon the passage of oil through a flow restrictor to keep from free falling. If the cylinder is not full of oil the wing will drop and may cause damage to the machine.

Wings Unfolded

Remove each Fold Cylinder Rod End Pin and block each Fold Cylinder Rod End up to allow for rod movement. Completely extend and retract Fold and Lift Cylinders. Check tractor oil reservoir. Extend and retract the Cylinders completely 5-6 times to purge air from the Hydraulic Circuit. The Cylinders should be working smoothly through the stroke, if not repeat. Do not loosen hoses/fittings. Recheck tractor reservoir oil level. Hydraulic Circuit requires approximately 4-1/2 to 6 gallons of hydraulic oil depending on the Model. After the Hydraulic Circuit has been purged, reconnect the Fold Cylinder Rod Ends to the Wing Fold Links.

Wings Folded

Start unfolding the wings part way never past center and then refolding the wings approximately 5 or 6 times or more, until all air is out of the circuit.

Transport Axle

Raise and lower the machine from field position to transport position 2 to 3 times to insure proper functioning of the Hydraulic Circuit. This machine is hydraulically controlled by one circuit which controls the lift of the machine and folding of the wings.

The sequence for the hydraulic circuit is as follows:

Field Position to Transport Position:

1. Machine raises on transport wheels.
2. Wings fold.
3. Install Transport Lock Pin. **See Figure 3-6.**

Transport Position to Field Position:

1. Remove Transport Lock Pin and place in storage. **See Figure 3-7.**
2. Wings unfold.
3. Machine lowers to the ground.

Roller Bearing Maintenance

If bearings are removed from frame refer to the steps below to ensure minimum axle load is applied to prolong bearing life.

1. With the Bearing Grease Fitting facing towards the rear or upward of the machine, slide the Trunnion Bearing Mounts onto the Trunnion Bearings and lift the Roller Assembly up to the Center Frame Bearing Hangers. Hand tighten 3/4-10 hardware to hold Trunnion Bearing Mounts in place.
2. Look at each Trunnion Bearing Mount to make sure that it is sitting perpendicular to the Center Frame Bearing Hanger. If not adjust the Shim Washers accordingly, for each side there are two 11ga and one 14ga Shim Washers. Shim Washers can be all three on the inside between the Stub Shaft shoulder and the Trunnion Bearing, all three can be on the outside between the Trunnion Bearing and Flat Top Washer, or a combination on either side, but all three must be used to minimize the gap. If gap cannot be properly minimized with bearing snap rings to outside, turn bearing around to have snap ring to inside. The bearing inner race is offset with respect to the trunnion bosses by 1/32". By installing bearings with snap rings in versus out, 1/16" difference can be made up at assembly if needed. **See Figure 4-4.**
3. Tighten 3/4-10 and 1-8 hardware to specification per torque chart. **See Page 4-1.**

NOTE

Wheel Stop is on the Clamp side of the Roller Assembly.

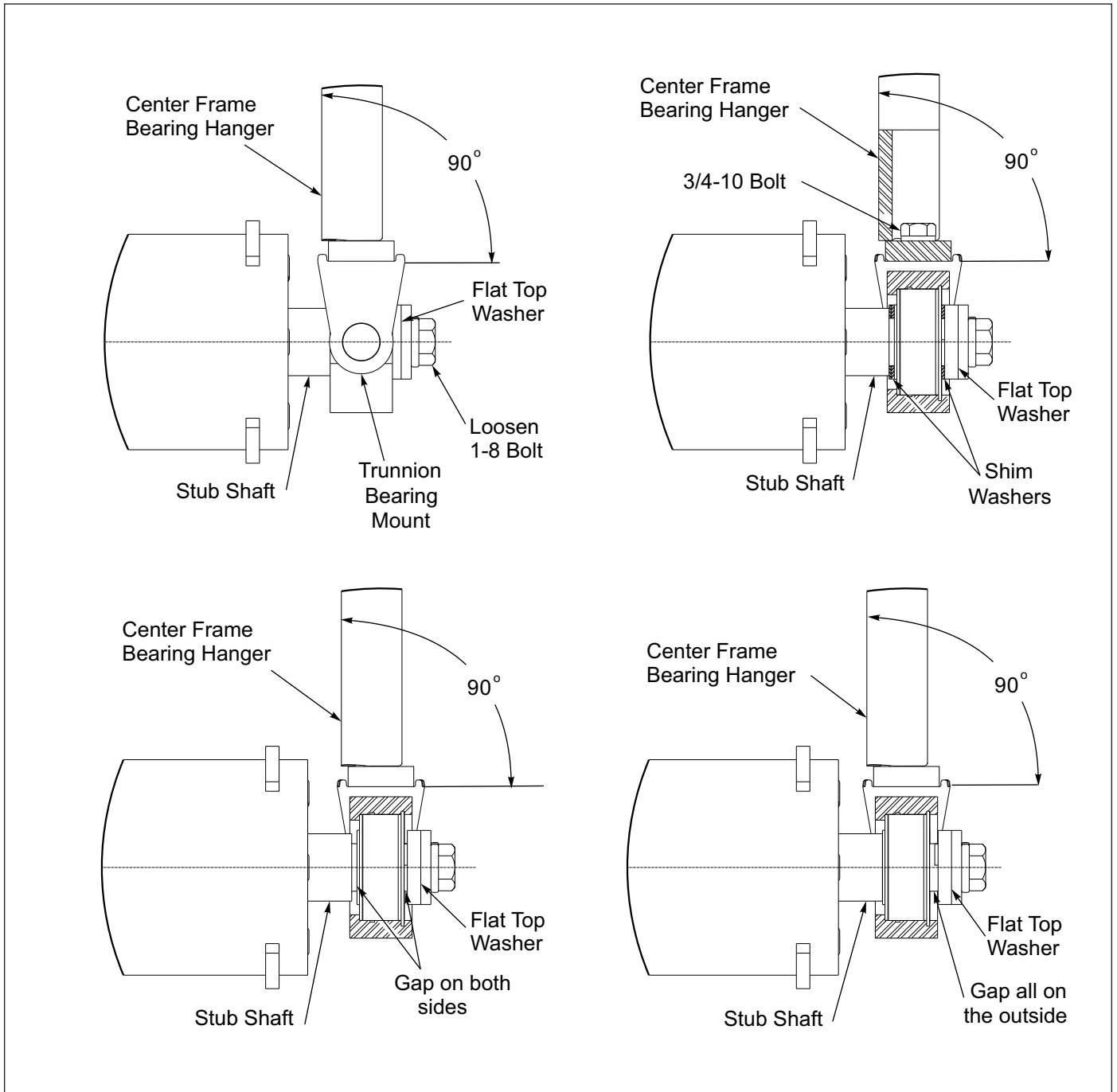

Figure 4-4: Trunnion Spacing

Roller Axle Assembly

After an initial run of 5-10 hours, check the Roller Axle Assemblies to ensure that the wheels are tight to one another. If not, starting at the welded stop end, slide the wheels tight together and adjust the Axle Clamps so that it's against the wheel. **See Figure 4-5.** If there is a gap between the Axle Clamp and the Wheel Stop, install the appropriate clamp spacers. **See Figure 4-7 and 4-8.**

Clamp Tightening

Tighten the Clamp bolts evenly to achieve equal spacing between clamp section. Torque to 75 ft-lbs. Thereafter check assemblies every 50-100 hours. **See Figure 4-6.**

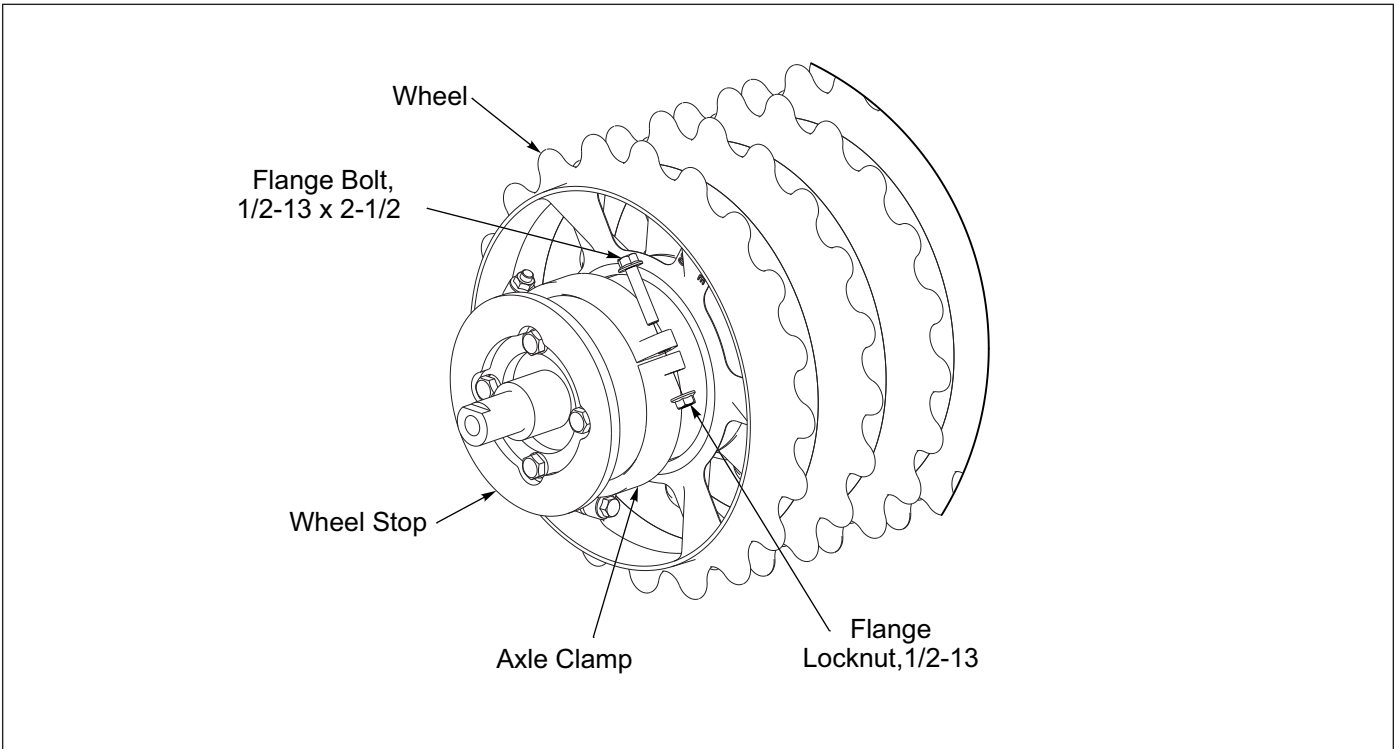

Figure 4-5: Roller Axle Assembly

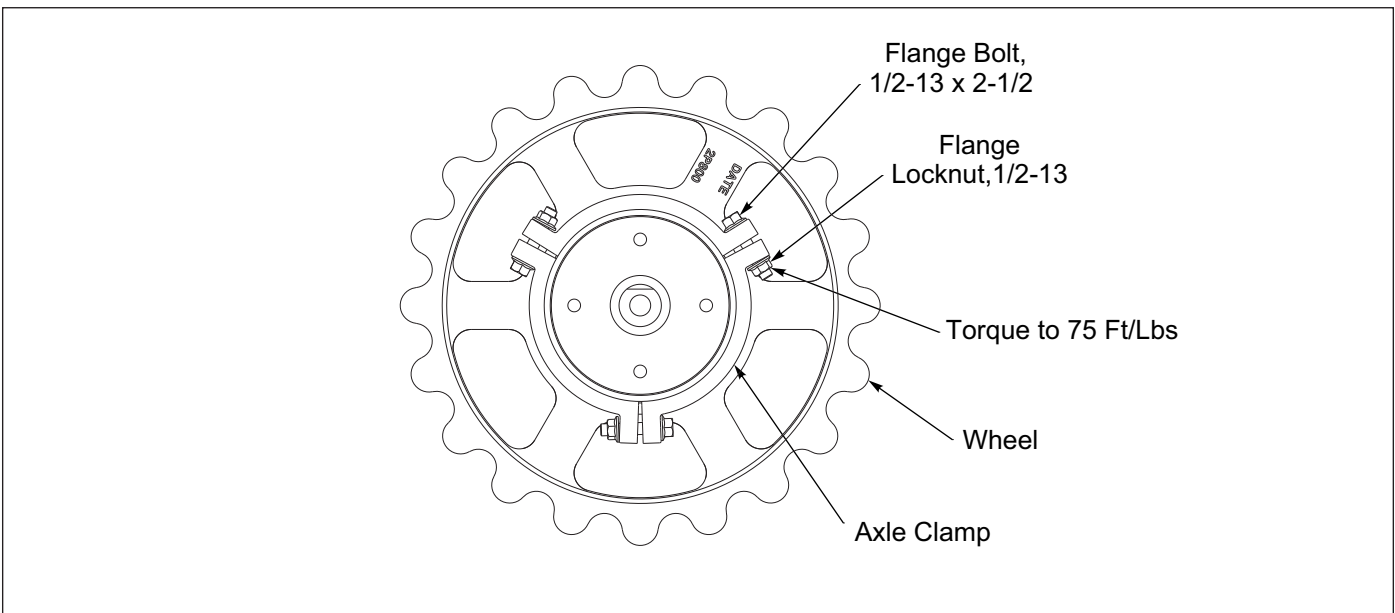

Figure 4-6: Clamp Tightening

Clamp End Spacers - Optional

The Clamp End Spacer Kits are used to eliminate space between the Axle Clamp and the Wheel Stop.

IMPORTANT

Unfold and lower machine prior to performing any steps.

Kit Part Number 201442 - 3/4" Axle Spacer

Kit Part Number 201443 - 1/2" Axle Spacer

Installation is the same for either kit.

1. Place the two Axle Spacers between the Axle Clamp and the Wheel Stop.
2. Insert two 3/8-16 x 1-3/4 Bolts through the Axle Spacers and secure with 3/8-16 Locknuts.

Refer to the Torque Table for proper bolt torque values. Note the different torque requirement for Bolts with Locknut. **See Page 4-1.**

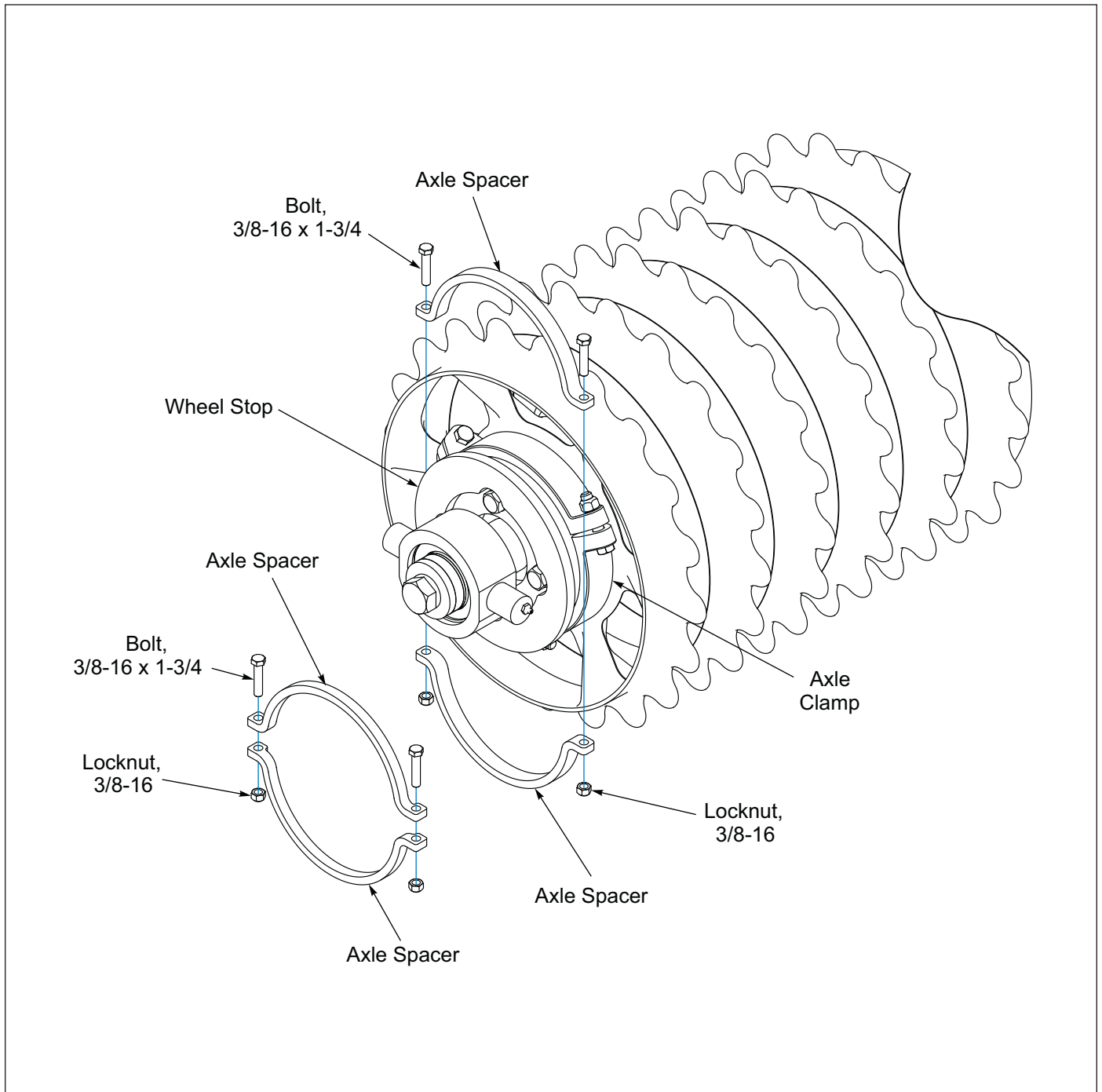

Figure 4-7: Clamp End Spacer Kit, 1 of 2 - Optional

Kit Part Number 204831 - 1" Axle Spacer

Kit Part Number 204832 - 1-1/4" Axle Spacer

Kit Part Number 204833 - 1-1/2" Axle Spacer

1. Place the two Axle Spacers between the Axle Clamp and the Wheel Stop.
2. Insert two 3/8-16 x 1 Bolts through the Axle Spacers and secure with 3/8-16 Locknuts.

Refer to the Torque Table for proper bolt torque values.

Note the different torque requirement for Bolts with Locknuts. **See Page 4-1.**

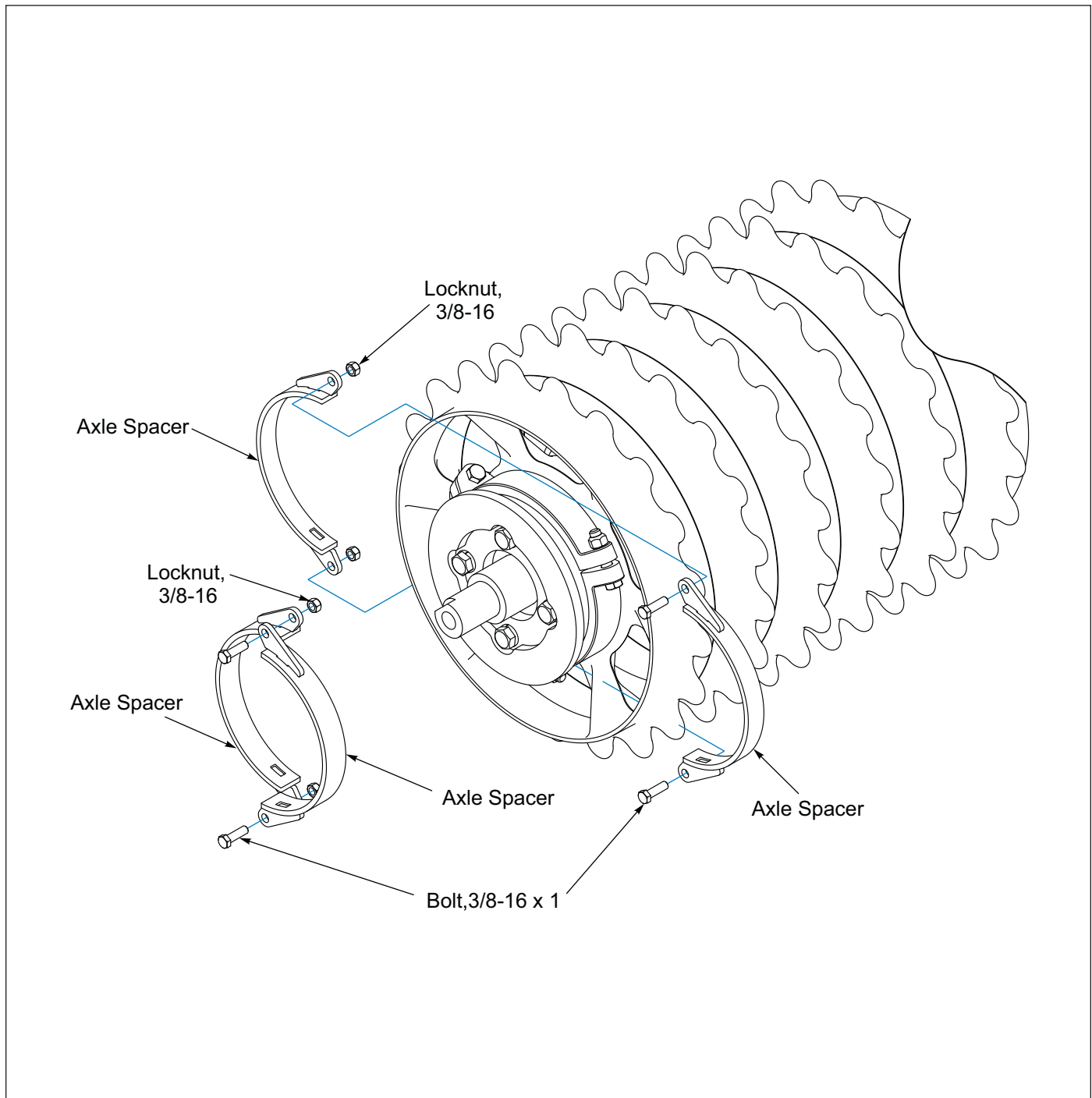

Figure 4-8: Clamp End Spacer Kit, 2 of 2 - Optional

LED Warning Lamps

When plugging in the LED 7-pin connector:

1. Make sure the tractor has a good clean receptacle, free of dirt and corrosion.
2. Make sure the 7-pin connector is inserted ALL the way in. With tighter fitting pins, operator may think the connector is all the way in, but really isn't.
3. Make sure the tractor receptacle cover latches over the keyway on the 7-pin connector to hold the connector in place.

If an operator plugs in the 7-pin connector, but the lights do not seem to work right, check the above items to make sure there is a good connection with the 7-pin connector.

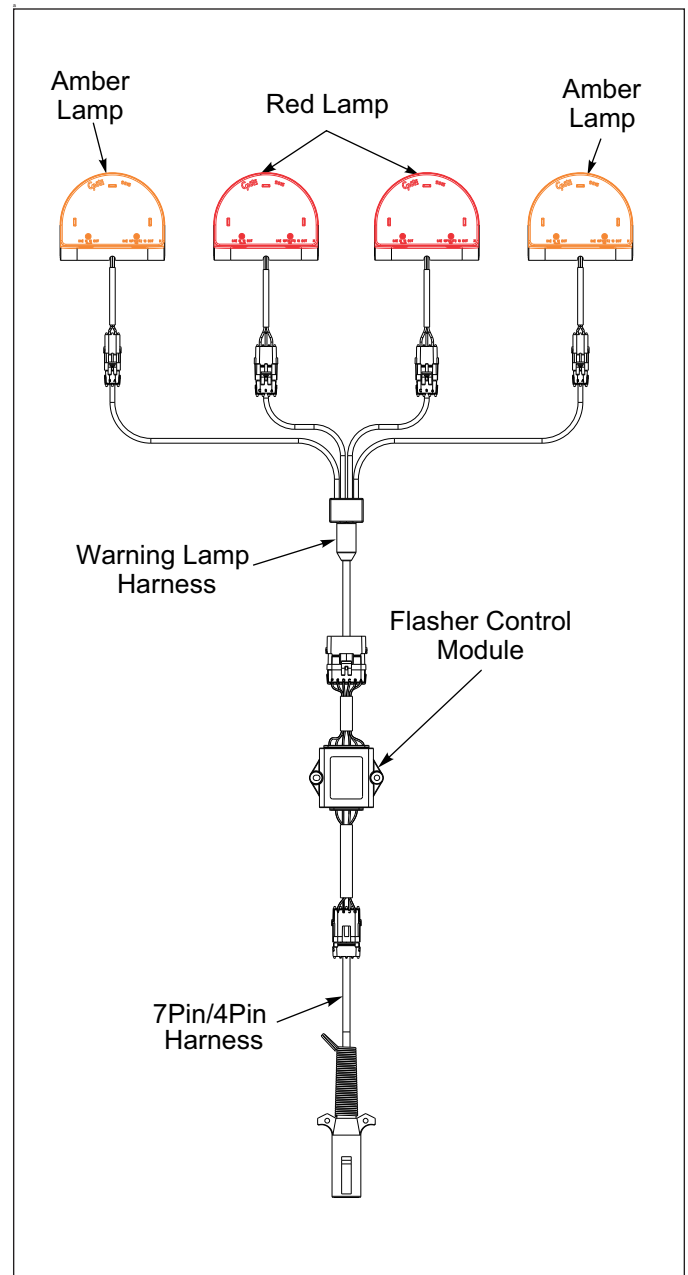

Figure 4-9: LED Warning Lamps

Acre Meter Troubleshooting

IMPORTANT

Acre Meter is dust and splash resistant, under no circumstances should this unit be submerged in any conductive, corrosive, or flammable liquid. At no time use high pressure water or air to clean it, as this can damage the unit.



Figure 4-10: Acre Meter Notice

NOTE

The ground wire is for static discharge protection and has no effect on the ability of the sensor to function properly under normal conditions.

The battery operated Acre Meter uses 3 AA batteries. The Acre Meter will display “**LObat**” when the batteries require replacement. Remove the Acre Meter from the implement and then the 4 Screws on the back of the case. Separate the housing from the rear plate. Replace with 3 quality AA batteries.

Acre Meter does not count pulses during calibration or does not count acres during operation.

1. Check the position of the Magnet Wheel Assembly and Pick-up Switch against the set-up instructions in this manual. **See Figure 2-25.**
2. Verify that the magnet in the Magnet Wheel Assembly has not come out.
3. Place the Acre Meter display in “Calibrate” mode by pressing the ***(FUNC)** key until the P-Word indicator is lit and then press the up/down arrow keys until the display shows 0 and the LED is blinking. Break the connection between the display and the Pick-up Switch and short between pins A and B on the display harness connector. You should see the display increment +1 with each contact of the connector terminals.

4. If step 3 works then wave a magnet in front of the Pick-up Switch face with it re-connected to the display and see if the display increments up. If not, put an ohm meter or continuity tester on the contacts of the Pick-up Switch harness and place a magnet in front of the Pick-up Switch face. The Pick-up Switch should show continuity or near 0 ohms resistance.

Acre Meter can not change the width or pulse count settings or clear the field and total acres.

1. Check to see if a password needs to be entered by pressing the ***(FUNC)** key until the P-Word indicator LED is lit. If “**dis**” is displayed (password disabled) no password is set.
2. If “**Ent**” is displayed a password must be entered to change the settings or the password must be disabled as instructed in the setup section of this manual.

Storage

1. The service life of the Seeder will be extended by proper off-season storage practices. Prior to storing the unit, complete the following procedures:
 - a. Completely clean the unit.
 - b. Inspect the machine for worn or defective parts. Replace as needed.
 - c. Repaint all areas where the original paint is worn off.
 - d. Apply a light coating of oil or grease to exposed cylinder rods to prevent them from rusting.
 - e. Lubricate each point of the machine as stated in “**Lubrication Maintenance**” on page 4-4.
2. Store the unit in a shed or under a tarpaulin to protect it from the weather. The ground tools and tires should rest on boards, or some other object, to keep them out of the soil.
3. If the unit is stored in the folded position, raise the machine and install Transport Lock Pin. Lower Drawbar Jack. **See Figure 3-6.**
 - a. Relieve Hydraulic Pressure in hoses after Transport Lock Pin is installed.
 - b. Block wheels before unhitching from tractor.

Maintenance Chart

Maintenance Chart

(Subject to change without notice)

	Initial Run-In	20 Hours	50 Hours	Annually	Storage
Fasteners, Wheel Hub Bolts	X			X	
Grease Wing Hinge Pins		X			
Grease Transport Toggle Link Weldment		X			
Grease Spherical Bearing		X			
Grease Trunnion Bearings		X			
Grease Turnbuckle			X		
Grease Wheel Hubs			X	X	
Repack Wheel Hub Bearings				X	
Adjust Scraper if equipped			X		
Tighten Roller Wheels and Clamps			X		
** Clean machine					X
Grease after cleaning					X
Touch-up paint					X

*** Avoid spraying high pressure washer directly at bearing seals and electrical connections.*

Troubleshooting

PROBLEM	PROBABLE CAUSE	SOLUTION
Center Roller Bulldozes	Wing Hinge roller is not in the correct position	Adjust Turnbuckle to locate Wing Hinge Roller in the lower 1/3 of Guide Slot
Warning Lights Do Not Work	Connections loose	Connect loose connection
	Bulbs burned out	Change bulb
	Power supply absent	Repair power source
	Light module failure	Replace light module
Wings Do Not Fold	External hydraulic leak	Repair leak
	Not enough tractor hydraulic pressure <i>Note: Need 2,000 PSI on 36 ft machine, less or smaller</i>	Increase hydraulic pressure
	Internal hydraulic cylinder leakage <i>Note: Does the cylinder get warm with rod completely extended or retracted and the hydraulic circuit still activated? Heat indicates leakage</i>	Repair or replace hydraulic cylinder
Center Lowers Before Wings Unfold	Too much hydraulic flow <i>Note: Wing hydraulic cylinders have restrictors, if flow is too great, backpressure increases and rockshaft hydraulic cylinder becomes activated</i>	Reduce hydraulic fluid flow
Leaving Tire Tracks In Field.	Transport axle hydraulic cylinder isn't fully retracted	Retract transport axle hydraulic cylinder <i>Note: Make sure that they wing hydraulic cylinders are completely extended</i>
	External hydraulic leak	Repair leak
	Air in hydraulic circuit	Bleed air from hydraulic circuit
	Internal hydraulic cylinder leakage <i>Note: Does they cylinder get warm the rod completely extended or retracted and the hydraulic circuit still activated? Heat indicates internal leakage</i>	Repair or replace hydraulic cylinder
	Tractor valve does not hold pressure	Repair tractor valve
	Top Link not adjusted properly	Adjust Turnbuckle to locate Wing Hinge Roller in the lower 1/3 of Guide Slot

General Reference and Specifications

Model Designation

- Basic model is denoted by “WFP” - Wing Float Pulverizer.
- Axle Wheel type is denoted by “D” - Ductile 20” Notched.
- Scrapers are standard on models denoted by “S”.
- Approximate working rolling width is denoted by the last digits in Model Number representing feet.

Product Attributes	WFP23	WFP25	WFP27	WFP29
Approximate Weight				
(WFPDS) 20” Notched Ductile Iron Wheels with Scrapers	7,205 lbs. (3,268 kg)	7,494 lbs. (3,399 kg)	7,779 lbs. (3,528 kg)	8,359 lbs. (3,792 kg)
(WFPD) 20” Notched Ductile Iron Wheels Excluding Scrapers	6,985 lbs. (3,168 kg)	7,259 lbs. (3,293 kg)	7,521 lbs. (3,411 kg)	8,085 lbs. (3,667 kg)
(WFPO) 20” Optimizer Ductile Iron Wheels	7,270 lbs. (3,298 kg)	7,575 lbs. (3,436 kg)	7,866 lbs. (3,568 kg)	8,462 lbs. (3,838 kg)
(WFPC) 20” Crowfoot Ductile Iron Wheels	6,440 lbs. (2,921 kg)	6,670 lbs. (3,025 kg)	6,895 lbs. (3,128 kg)	7,435 lbs. (3,372 kg)
Approximate Tongue Weight				
Drawbar Retracted, Transport	N/A	N/A	N/A	1,800 lbs. (816 kg)
Drawbar Extended, Transport	1,300 lbs. (590 kg)	1,300 lbs. (590 kg)	1,300 lbs. (590 kg)	1,400 lbs. (635 kg)
Operation				
Working Width	Under 100 lbs. (45 kg)	Under 100 lbs. (45 kg)	Under 100 lbs. (45 kg)	Under 100 lbs. (45 kg)
Transport Width	23 ft. 4 in. (7.1 m)	25 ft. 4 in. (7.7 m)	27 ft. 4 in. (8.3 m)	29 ft. 4 in. (8.9 m)
Transport Height	14 ft. 0 in. (4.3 m)	14 ft. 0 in. (4.3 m)	14 ft. 0 in. (4.3 m)	14 ft. 0 in. (4.3 m)
Overall Length, Drawbar Retracted	8 ft. 4 in. (2.5 m)	8 ft. 8 in. (2.6 m)	9 ft. (2.7 m)	9 ft. 4 in. (2.8 m)
Overall Length, Drawbar Extended	N/A	N/A	N/A	17 ft. (5.2 m)
Overall Length, Rigid Drawbar	N/A	N/A	N/A	22 ft. (6.7 m)
Road Clearance	21 ft. (6.4 m)	21 ft. (6.4 m)	21 ft. (6.4 m)	N/A
Automatic Transport Lock	11.5 in. (292 mm)	11.5 in. (292 mm)	11.5 in. (292 mm)	11.5 in. (292 mm)
Hydraulic Circuits Required	Standard	Standard	Standard	Standard
Number of Pulverizer Wheels	1	1	1	1
(WFPDS) 20” Notched Ductile Iron Wheels with Scrapers	72	78	84	90
(WFPD) 20” Notched Ductile Iron Wheels Excluding Scrapers	72	78	84	90
(WFPO) 20” Optimizer Ductile Iron Wheels	47	51	55	59
(WFPC) 20” Crowfoot Ductile Iron Wheels	47	51	55	59
Axle Size	8 in. (203 mm)	8 in. (203 mm)	8 in. (203 mm)	8 in. (203 mm)
Hitch	Pull-Type with Hydraulic Transport	Pull-Type with Hydraulic Transport	Pull-Type with Hydraulic Transport	Pull-Type with Hydraulic Transport
Tire Size	11L x 15-12 Ply Tires on 6 Bolt Rims	11L x 15-12 Ply Tires on 6 Bolt Rims	11L x 15-12 Ply Tires on 6 Bolt Rims	11L x 15-12 Ply Tires on 6 Bolt Rims
Scraper Kits	Standard on Models with “S”	Standard on Models with “S”	Standard on Models with “S”	Standard on Models with “S”
WFP Float Lock Kit	Optional	Optional	Optional	Optional
WFP Hydraulic Top Link Kit	Optional	Optional	Optional	Optional
Telescoping Drawbar	Optional	Optional	Optional	Standard
Electronic Acre Meter Kit	Optional	Optional	Optional	Optional
LED Safety Warning Lights & SMV Emblem	Standard	Standard	Standard	Standard
Safety Chain Kit	Standard	Standard	Standard	Standard
Powder Coat Paint, Red	Standard	Standard	Standard	Standard
Horsepower Requirements	3 to 5 HP per ft. (2.2 to 3.7 kW per m)	3 to 5 HP per ft. (2.2 to 3.7 kW per m)	3 to 5 HP per ft. (2.2 to 3.7 kW per m)	3 to 5 HP per ft. (2.2 to 3.7 kW per m)
Horsepower Requirements As Companion Tool	1 to 3 HP per ft. (0.75 to 2.2 kW per m)	1 to 3 HP per ft. (0.75 to 2.2 kW per m)	1 to 3 HP per ft. (0.75 to 2.2 kW per m)	1 to 3 HP per ft. (0.75 to 2.2 kW per m)
Recommended Operating Speed	5 to 8 MPH (8 to 12.9 km/h)	5 to 8 MPH (8 to 12.9 km/h)	5 to 8 MPH (8 to 12.9 km/h)	5 to 8 MPH (8 to 12.9 km/h)

Specifications subject to change with or without notice.

Figure 5-1: WFP23-29 Models

TABLE OF CONTENTS

Product Attributes	WFP31	WFP33	WFP35	WFP37
Approximate Weight				
(WFPDS) 20" Notched Ductile Iron Wheels with Scrapers	8,677 lbs. (3,936 kg)	9,085 lbs. (4,121 kg)	9,331 lbs. (4,232 kg)	9,719 lbs. (4,408 kg)
(WFPD) 20" Notched Ductile Iron Wheels Excluding Scrapers	8,387 lbs. (3,804 kg)	8,780 lbs. (3,983 kg)	9,003 lbs. (4,084 kg)	9,375 lbs. (4,252 kg)
(WFPO) 20" Optimizer Ductile Iron Wheels	8,795 lbs. (3,989 kg)	9,217 lbs. (4,181 kg)	9,470 lbs. (4,296 kg)	9,873 lbs. (4,478 kg)
(WFPC) 20" Crowfoot Ductile Iron Wheels	7,733 lbs. (3,508 kg)	8,045 lbs. (3,649 kg)	8,325 lbs. (3,776 kg)	8,550 lbs. (3,878 kg)
Approximate Tongue Weight				
Drawbar Retracted, Transport	1,800 lbs. (816 kg)	1,850 lbs. (839 kg)	1,850 lbs. (839 kg)	1,850 lbs. (839 kg)
Drawbar Extended, Transport	1,400 lbs. (635 kg)	1,500 lbs. (680 kg)	1,500 lbs. (680 kg)	1,500 lbs. (680 kg)
Operation	Under 100 lbs. (45 kg)	Under 100 lbs. (45 kg)	Under 100 lbs. (45 kg)	Under 100 lbs. (45 kg)
Working Width	31 ft. 4 in. (9.6 m)	33 ft. 4 in. (10.2 m)	35 ft. 4 in. (10.8 m)	37 ft. 4 in. (11.4 m)
Transport Width	14 ft. 0 in. (4.3 m)	14 ft. 0 in. (4.3 m)	14 ft. 0 in. (4.3 m)	14 ft. 0 in. (4.3 m)
Transport Height	9 ft. 8 in. (2.9 m)	10 ft. 2 in. (3.1 m)	10 ft. 6 in. (3.2 m)	10 ft. 10 in. (3.3 m)
Overall Length, Drawbar Retracted	17 ft. (5.2 m)	17 ft. (5.2 m)	18 ft. (5.5 m)	18 ft. (5.5 m)
Overall Length, Drawbar Extended	22 ft. (6.7 m)	22 ft. (6.7 m)	23 ft. (7.0 m)	23 ft. (7.0 m)
Overall Length, Rigid Drawbar	N/A	N/A	N/A	N/A
Road Clearance	11.5 in. (292 mm)	11.5 in. (292 mm)	11.5 in. (292 mm)	11.5 in. (292 mm)
Automatic Transport Lock	Standard	Standard	Standard	Standard
Hydraulic Circuits Required	1	1	1	1
Number of Pulverizer Wheels				
(WFPDS) 20" Notched Ductile Iron Wheels with Scrapers	96	102	108	114
(WFPD) 20" Notched Ductile Iron Wheels Excluding Scrapers	96	102	108	114
(WFPO) 20" Optimizer Ductile Iron Wheels	63	67	71	75
(WFPC) 20" Crowfoot Ductile Iron Wheels	63	67	71	75
Axle Size	8 in. (203 mm)	8 in. (203 mm)	8 in. (203 mm)	8 in. (203 mm)
Hitch	Pull-Type with Hydraulic Transport	Pull-Type with Hydraulic Transport	Pull-Type with Hydraulic Transport	Pull-Type with Hydraulic Transport
Tire Size	11L x 15-12 Ply Tires on 6 Bolt Rims	11L x 15-12 Ply Tires on 6 Bolt Rims	11L x 15-12 Ply Tires on 6 Bolt Rims	11L x 15-12 Ply Tires on 6 Bolt Rims
Scraper Kits	Standard on Models with "S"	Standard on Models with "S"	Standard on Models with "S"	Standard on Models with "S"
WFP Float Lock Kit	Optional	Optional	Optional	Optional
WFP Hydraulic Top Link Kit	Optional	Optional	Optional	Optional
Telescoping Drawbar	Standard	Standard	Standard	Standard
Electronic Acre Meter Kit	Optional	Optional	Optional	Optional
LED Safety Warning Lights & SMV Emblem	Standard	Standard	Standard	Standard
Safety Chain Kit	Standard	Standard	Standard	Standard
Powder Coat Paint, Red	Standard	Standard	Standard	Standard
Horsepower Requirements	3 to 5 HP per ft. (2.2 to 3.7 kW per m)	3 to 5 HP per ft. (2.2 to 3.7 kW per m)	3 to 5 HP per ft. (2.2 to 3.7 kW per m)	3 to 5 HP per ft. (2.2 to 3.7 kW per m)
Horsepower Requirements As Companion Tool	1 to 3 HP per ft. (0.75 to 2.2 kW per m)	1 to 3 HP per ft. (0.75 to 2.2 kW per m)	1 to 3 HP per ft. (0.75 to 2.2 kW per m)	1 to 3 HP per ft. (0.75 to 2.2 kW per m)
Recommended Operating Speed	5 to 8 MPH (8 to 12.9 km/h)	5 to 8 MPH (8 to 12.9 km/h)	5 to 8 MPH (8 to 12.9 km/h)	5 to 8 MPH (8 to 12.9 km/h)

Specifications subject to change with or without notice.

Figure 5-2: WFP31-37 Models

Document Control Revision Log:

Date	Form #	Improvement(s): Description and Comments
01/2021	F-1108-0121	Initial Release



Intertek

Equipment from Landoll Company, LLC is built to exacting standards ensured by ISO 9001 registration at all Landoll manufacturing facilities.

Wing Float Pulverizer
Models: WFPD23-37, WFPO23-37 & WFPC23-37
With Scrapers: WFPDS23-37

Re-Order Part Number F-1108

LANDOLL COMPANY, LLC

1900 North Street

Marysville, Kansas 66508

(785) 562-5381

800-428-5655 ~ WWW.LANDOLL.COM



Copyright 2022. Landoll Company, LLC

“All rights reserved, including the right to reproduce this material or portions thereof in any form.”