

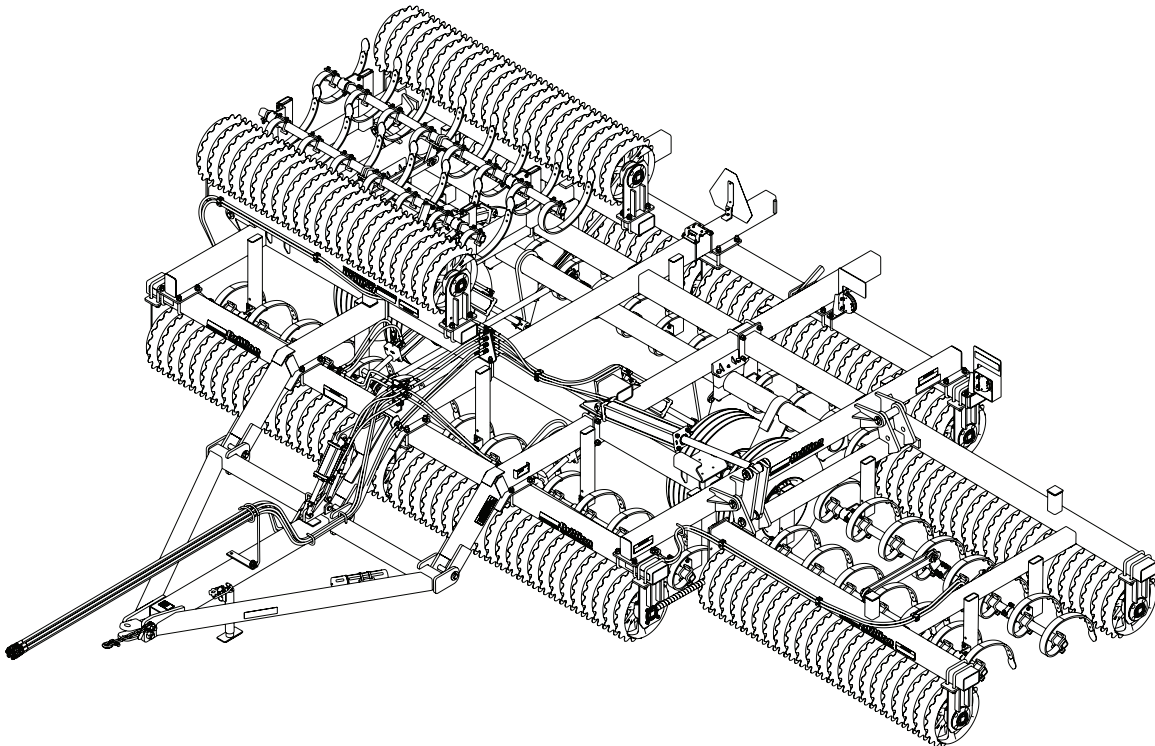

**WL360 Folding Pulvi-Mulcher
Models: WL,WLS,WCL,WCLS,
WLC,WLCS,WCC and WCCS
Operator's Manual**



LANDOLL COMPANY, LLC

1900 North Street

Marysville, Kansas 66508

(785) 562-5381

800-428-5655 ~ WWW.LANDOLL.COM

Manuals for WL360 Folding Pulvi-Mulcher

Manual Number	Manual Type
9J577	Operator's Manual
9J578	Parts Manual



DANGER

DO NOT operate or perform any maintenance tasks on this equipment until you have completed the following:

- 1. Receive proper training to operate this equipment safely.**
- 2. Read and understand the operator's manual.**
- 3. Be thoroughly trained on inspection and repair procedures.**

Failure to comply with this warning may result in serious injury or possibly death.

Table of Contents

1 Safety Information

Introduction	1-1
Description of Unit	1-1
Using this Manual	1-1
Owner Assistance	1-1
Warranty Registration	1-1
Safety	1-2
Understanding Safety Statements	1-2
Transporting Safety	1-2
Prepare for Emergencies	1-2
Safety Instructions for Towing Vehicles	1-3
Attaching, Detaching and Storage	1-3
Maintenance Safety	1-3
Protective Equipment	1-3
Chemical Safety	1-3
High Pressure Fluid Safety	1-3
Tire Safety	1-3
Safety Chain	1-4
Decals	1-5

2 Assembly

Frame Assembly	2-2
Frame Assembly Dimensions	2-4
Center Bearing Brackets Offset	2-5
Rockshaft Installation	2-6
Tire Installation	2-7
Drawbar and Transport Lock Installation	2-8
Tooth Tube Bracket Assembly	2-10
Center Frame Tooth Bracket Locations	2-11
Tooth or Tine Installation	2-12
Center Frame Tooth Locations	2-13
Center Frame S-Tine Installation	2-14
Center Frame C-Tooth Installation	2-16
Wing Hinge and Fold Cylinder Installation	2-18
Wing Tooth Tube Bracket Assembly	2-20
Wing Frame Tooth Locations	2-21
Wing Frame S-Tine Installation	2-22
Wing Frame C-Tooth Installation	2-24

Hydraulic Installation	2-26
Purging the Hydraulic Wing Fold, Transport and Tooth Control Cylinders. . .	2-26
Hydraulic Fold Circuit	2-32
Hydraulic Tooth Control Circuit.	2-33
Hydraulic Lift Circuit	2-34
Center Roller Installation	2-36
Wing Roller Installation.	2-37
Rear Scraper Assembly	2-38
LED Lamp and Harness Installation	2-40
Front Scraper Installation - Optional.	2-44
Land Leveler Installation - Optional	2-46
V-Leveler Installation - Optional	2-48
Rear Hitch Installation - Optional	2-50

3 Operation

Tractor Preparation.	3-1
Pulvi-Mulcher Preparation	3-1
Attaching to the Tractor	3-2
Hydraulic Fold System	3-3
Hydraulic Lift System	3-3
Hydraulic Tooth Control System.	3-4
General Operation	3-4
Rockshaft and Drawbar Transport Locks	3-5
Drawbar Transport Lock.	3-6
Scraper Adjustment	3-6
Transport	3-7
Land and V-Leveler Adjustment - Optional.	3-8

4 Maintenance

General Torque Specifications	4-1
Hydraulic Fitting Torque Specifications	4-2
Fasteners	4-2
Wheel Bearing Maintenance	4-3
Hydraulic Maintenance	4-3
Roller Axle Wheels	4-4
Lubrication Maintenance	4-4
Tires	4-5
Warning Lamps	4-5
Storage.	4-6
Maintenance Chart.	4-6

5 Specifications

Model Designation 5-1
Accessories & Optional Equipment. 5-1
Hydraulic Fluid Capacities. 5-1
Model Specifications 5-2

Safety Information

Introduction

The implement described in this manual has been designed with care and built by skilled workers using quality materials and processes. Proper assembly and maintenance will provide you with satisfactory use for seasons to come.



DANGER

Read this entire manual before attempting to assemble, adjust or operate this implement. Failure to comply with this warning can result in personal injury or death, damage to the implement or its components and inferior operation.

Description of Unit

Brillion WL Pulvi-Mulcher models provide the ultimate in high capacity seedbed preparation. The front rollers of the Pulvi-Mulcher break up surface clods. “C” shaped ribbon teeth or “S” spring tines loosen the soil up to 6” in depth and pull clods to the surface. The rear roller wheels then crush those clods and convert the soil into a firm, mulched seedbed that locks in moisture at the root level.

Using this Manual

This manual will familiarize you with safety, assembly, operation, adjustment, and maintenance. Read this manual and follow the recommendations to help ensure safe and efficient operation.

- The information in this manual is current at time of printing. Some parts may have changed to assure top performance.
- Location reference: Right and Left designations in this manual are determined by facing the direction the implement will travel during field operation, unless otherwise stated.

Owner Assistance

If customer service or repairs are needed, contact your Brillion dealer. They have trained personnel, parts and service equipment specially designed for Brillion products. Your implement’s parts should only be replaced with Brillion parts. If items covered in this manual are not understood, contact your local Brillion Dealer.

Warranty Registration

Brillion Farm Equipment, by Landoll, shall have no warranty obligation unless each product is registered, within 10 days of retail purchase, using the Landoll Company, LLC Ag Products on-line registration process. Please refer to the Ag Products Policy and Procedures Manual, accessible at www.landoll.com for step by step instructions regarding product registration.

Enter your product information below for quick reference. Refer to the ID plate as shown. **See Figure 1-1.**

MODEL NUMBER

SERIAL NUMBER

DATE OF PURCHASE

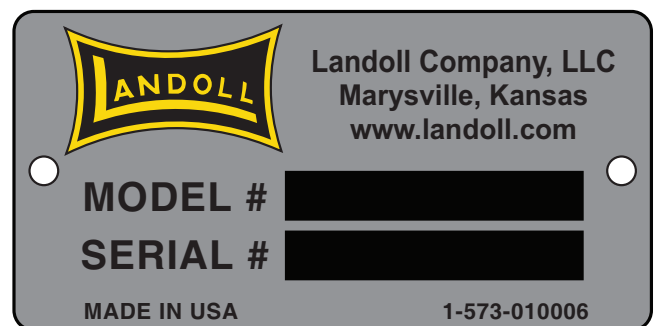

Figure 1-1: ID Plate

Safety

NOTE

Investigation has shown that nearly 1/3 of all farm accidents are caused by careless use of machinery. Insist that all people working with you or for you abide by all safety instructions.

Understanding Safety Statements

You will find various types of safety information on the following pages and on the implement decals (signs) attached to the implement. This section explains their meaning.

NOTICE

Special notice - read and thoroughly understand.



CAUTION

Proceed with caution. Failure to heed caution may cause injury to person or damage product.



WARNING

Proceed with caution. Failure to heed warning will cause injury to person or damage product.



DANGER

Proceed with extreme caution. Failure to heed notice will cause injury or death to person and/or damage product.

NOTE

You should read and understand the information contained in this manual and on the implement decals before you attempt to operate or maintain this equipment.

- Examine safety decals and be sure you have the correct safety decals for the implement. **See Figure 1-3.**
- Order replacement decals through your Brillion dealer.
- Keep these signs clean so they can be observed readily. It is important to keep these decals cleaned more frequently than the implement. Wash with soap and water or a cleaning solution as required.
- Replace decals that become damaged or lost. Also, be sure that any new implement components installed during repair include decals which are assigned to them by the manufacturer.

- When applying decals to the implement, be sure to clean the surface to remove any dirt or residue. Where possible, sign placement should protect the sign from abrasion, damage, or obstruction from mud, dirt, oil etc.



DANGER

- **Do not allow anyone to ride on the tractor or implement. Riders could be struck by foreign objects or thrown from the implement.**
- **Never allow children to operate equipment.**
- **Keep bystanders away from implement during operation.**

Transporting Safety

IMPORTANT

It is the responsibility of the owner/operator to comply with all state and local laws.

- When transporting the implement on a road or highway, use adequate warning symbols, reflectors, lights and slow moving vehicle sign as required. Slow moving tractors and towed implements can create a hazard when driven on public roads. They are difficult to see, especially at night.
- Do not tow an implement that, when fully loaded, weighs more than 1.5 times the weight of the towing vehicle.
- Carry reflectors or flags to mark the tractor and implement in case of breakdown on the road.
- Do not transport at speeds over 20 MPH under good conditions. Never travel at a speed which does not allow adequate control of steering and stopping. Reduce speed if towed load is not equipped with brakes.
- Avoid sudden stops or turns because the weight of the implement may cause the operator to lose control of the tractor. Use a tractor heavier than the implement.
- Use caution when towing behind articulated steering tractors; fast or sharp turns may cause the implement to shift sideways.
- Keep clear of overhead power lines and other obstructions when transporting. Know the transport height and width of your implement. **See “Specifications” on page 5-1.**

Prepare for Emergencies

- Keep a First Aid Kit and Fire Extinguisher handy
- Keep emergency numbers for the doctor, ambulance, hospital and fire department near the phone.

Safety Instructions for Towing Vehicles

The maximum travel speed is the lesser of

- the road conditions;
- The maximum specified ground speed;
 - for towing operations as indicated in this manual or SIS;
 - of the towed vehicle as indicated in its operator's manual, SIS, or information sign;
- The maximum ground speed of the towed equipment combination shall be limited to the lowest specified ground speed of any of the towed machines. This speed is the ground speed limitation.

EXAMPLE: If the tractor is capable of 25 mph, the first implement has a SIS for 19 mph, and the last implement's operator's manual states its specified ground speed is 15 mph, the towed equipment combination ground speed limitation is 15 mph.

Attaching, Detaching and Storage

- Do not stand between the tractor and implement when attaching or detaching implement unless both are not moving.
- Block implement so it will not roll when unhitched from the tractor.

Maintenance Safety

- Block the implement so it will not roll when working on or under it to prevent injury.
- Do not make adjustments or lubricate the machine while it is in motion.
- Make sure all moving parts have stopped.
- Understand the procedure before doing the work. Use proper tools and equipment.

Protective Equipment

- Wear protective clothing & equipment appropriate for the job. Avoid loose fitting clothing.
- Because prolonged exposure to loud noise can cause hearing impairment or hearing loss, wear suitable hearing protection, such as earmuffs or earplugs.

Chemical Safety

Agricultural chemicals can be dangerous. Improper use can seriously injure persons, animals, plants, soil and property.

- Read chemical manufactures instructions and store or dispose of unused chemicals as specified. Handle chemicals with care and avoid inhaling smoke from any type of chemical fire.
- Store or dispose of unused chemicals as specified by the chemical manufacturer.

High Pressure Fluid Safety

Escaping fluid under pressure can be nearly invisible and have enough force to penetrate the skin causing serious injury. Use a piece of cardboard, rather than hands, to search for suspected leaks.

- Any fluid injected into the skin must be surgically removed within a few hours or gangrene may result.
- Avoid the hazard by relieving pressure before disconnecting hydraulic lines.

NOTE

Wear protective gloves and safety glasses or goggles when working with hydraulic systems.

Tire Safety

Tire changing can be dangerous and should be performed by trained personnel using correct tools and equipment.

- When inflating tires, use a clip-on chuck and extension hose long enough to allow you to stand to one side, not in front of or over the tire assembly. Use a safety cage if available.
- When removing and installing wheels use wheel-handling equipment adequate for the weight involved.

Safety Chain

1. Use the Safety Chain to help control drawn machinery should it separate from the Tractor Drawbar.
2. Use a chain with a strength rating equal to or greater than the gross weight of towed machinery, which is 11,000 pounds minimum in accordance with ASAE S338.2 specifications. If two or more implements are pulled in tandem, a larger chain may be required. Chain capacity must be greater than the TOTAL weight of all towed implements.

A second chain should be used between each implement.

3. Attach the chain to the Tractor Drawbar support or specified anchor location. Allow only enough slack in the chain to permit turning. The distance from hitch pin to attachment point or intermediate support point should not exceed 9 inches. **See Figure 1-2.**
4. Replace the chain if any links or end fittings are broken, stretched or damaged.
5. Do not use a Safety Chain for towing.

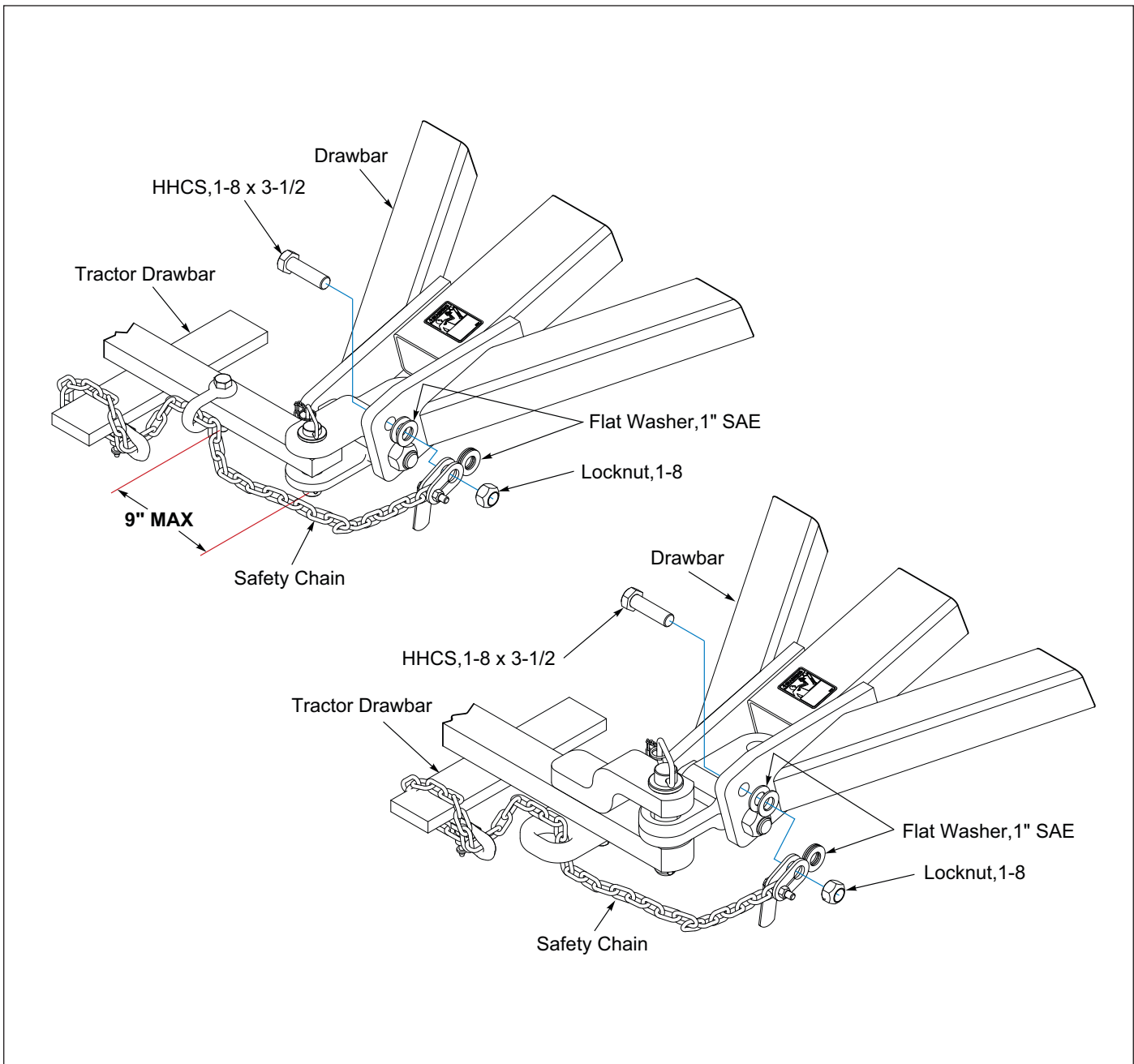
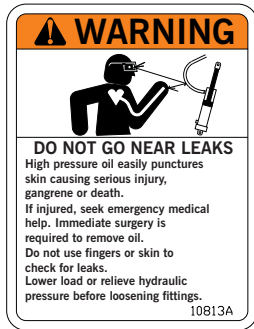
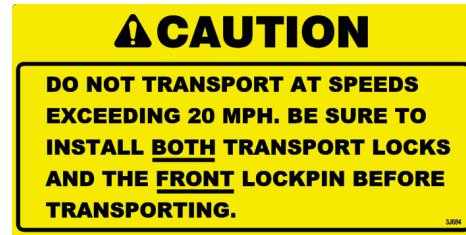

Figure 1-2: Safety Chain

Decals



ITEM 1
3K706



ITEM 2
3J684



ITEM 3
4K036



ITEM 4
3J675



ITEM 9
2P151

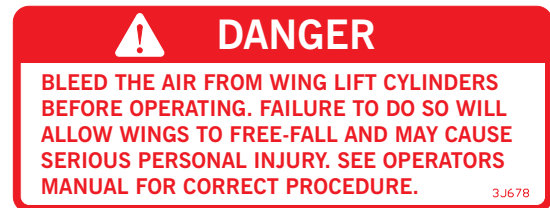

ITEM 8
3J678



ITEM 10
232191



ITEM 11
1-573-010006



ITEM 5 - 528933



ITEM 6 - 528938



ITEM 7 - 528934

Figure 1-3: Decals

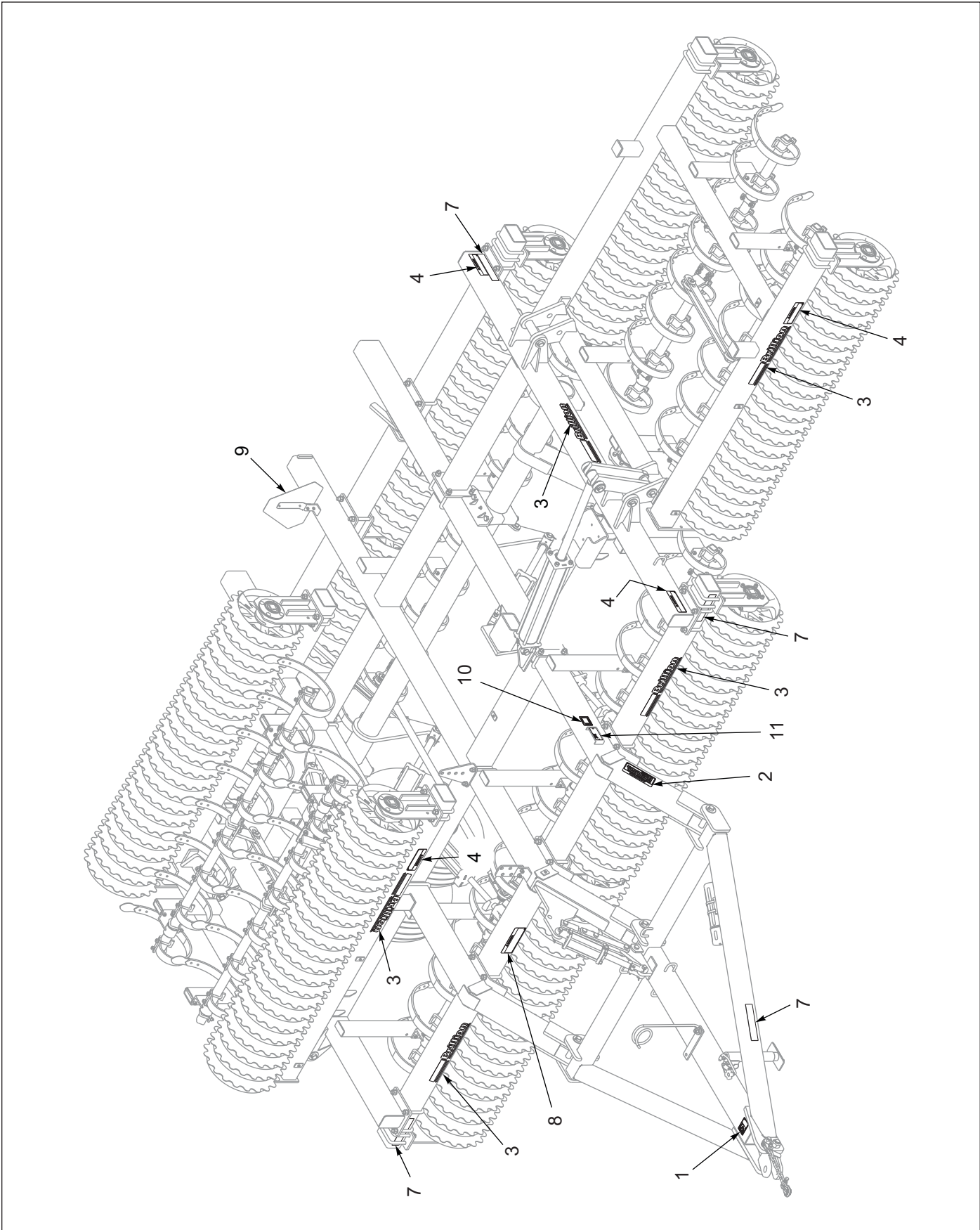

Figure 1-4: Front View

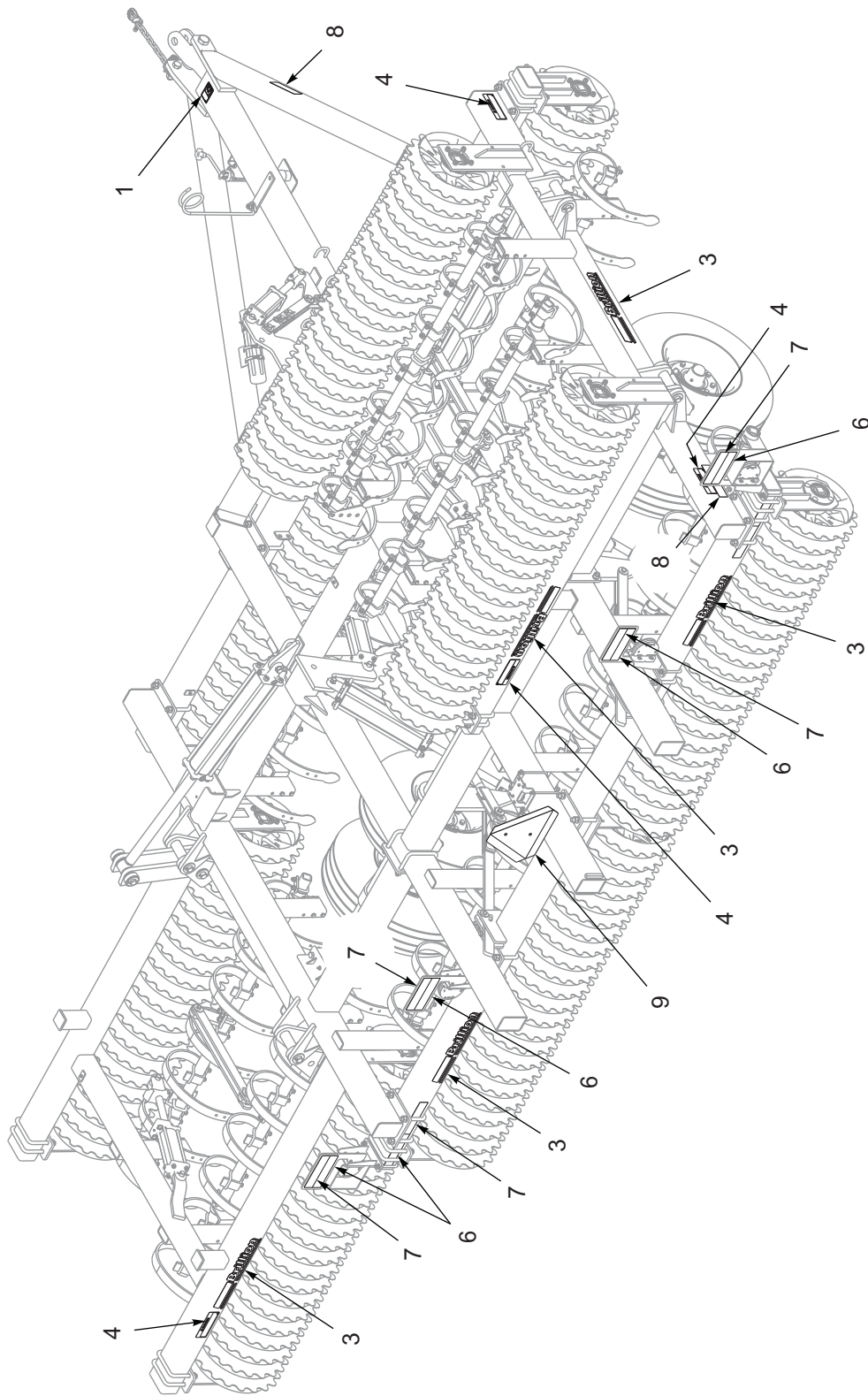

Figure 1-5: Rear View

**CAUTION**

Do not work on or under this machine unless securely blocked and supported by a hoist or tractor or by other sufficient means!

**WARNING**

Do not attempt to lift heavy parts (such as the frame, rock shaft, and pull hitch) manually. Use a hoist or a fork lift to move these parts into position.

The intent of this chapter is to provide instruction, allowing you to safely and correctly assemble your Brillion product.

NOTE

Refer to the repair parts manual 9J578 for identification of parts and for the approximate relationship of the parts in assembly.

IMPORTANT

- If a pre-assembled component or fastener is temporarily removed, ensure it is correctly re-installed per these instructions.
- Check that all working parts move freely, bolts are tight and cotter pins are spread.
- Refer to the Torque Table for proper torque values. Note the different torque requirements for bolts with lock nuts. **See Page 4-1.**

“Left” and “Right” refer to directions seen as if standing behind the machine and facing in the direction of forward travel.

Frame Assembly

1. Prior to starting assembly refer to **Figure 2-2** for proper frame placement dimensions. After laying out the dimensions use a chalk or other marker to help place the components.
2. Position the Rockshaft on a level surface under the designated frame assembly area. Lift arms should set on the floor and the wheel hubs should be toward the front of the machine also resting on floor. This will add in ease of assembly. **See Figure 2-1.**
3. Place front and rear frame tube on supports (about 2' high) spaced 15' apart. Be sure supports will hold 4000lbs each. Front frame should be placed such that the hydraulic bulkheads towards the center of the machine. Rear frame tube should be placed such that the holes in the Transport Lock Lugs are toward the center and top of the machine. **See Figure 2-1.**
4. Set center frame section in place so that it is centered on the front and rear frame tubes. Fasten together with 3/4-10 U-bolts, Lock Washers, and Nuts. Do not tighten at this time or put U-bolts in near the center tube of the center section. **See Figure 2-1.**
5. Set LH frame tube and RH frame tube in place on their respective sides of the center section. Attach cross members to center section and to front and rear tubes with 3/4-10 U-bolts, Lock Washers, and Nuts. **See Figures 2-1 and 2-2.**
6. Attach the Bulkhead Plate to the Center Frame Angle using 1/2-13 Bolts, Lock Washers and Nuts.
7. Attach the triangle shaped Bulkhead to the Center Frame Center Tube in front of the center frame cross member using 5/8-11 U-bolts, Lock Washers and Nuts. **See Figure 2-1.**
8. Attach Front Center Bracket which has no offset to the Center Frame using 3/4-10 Bolts, Lock Washers and Nuts. **See Figures 2-1 and 2-3.**
9. Attach the Rear Center Bracket to the Center Frame so the offset is to the right, using 3/4-10 Bolts, Lock Washers and Nuts. The offset allows room for the longer wheel and axle assembly to be mounted to the left. **See Figures 2-1 and 2-3.**
10. Run a tape measure across the frame diagonals if not square make adjustments. Tighten all fasteners at this time.

Refer to the Torque Table for proper torque values. Note the different torque requirements for bolts with lock nuts. **See Page 4-1.**

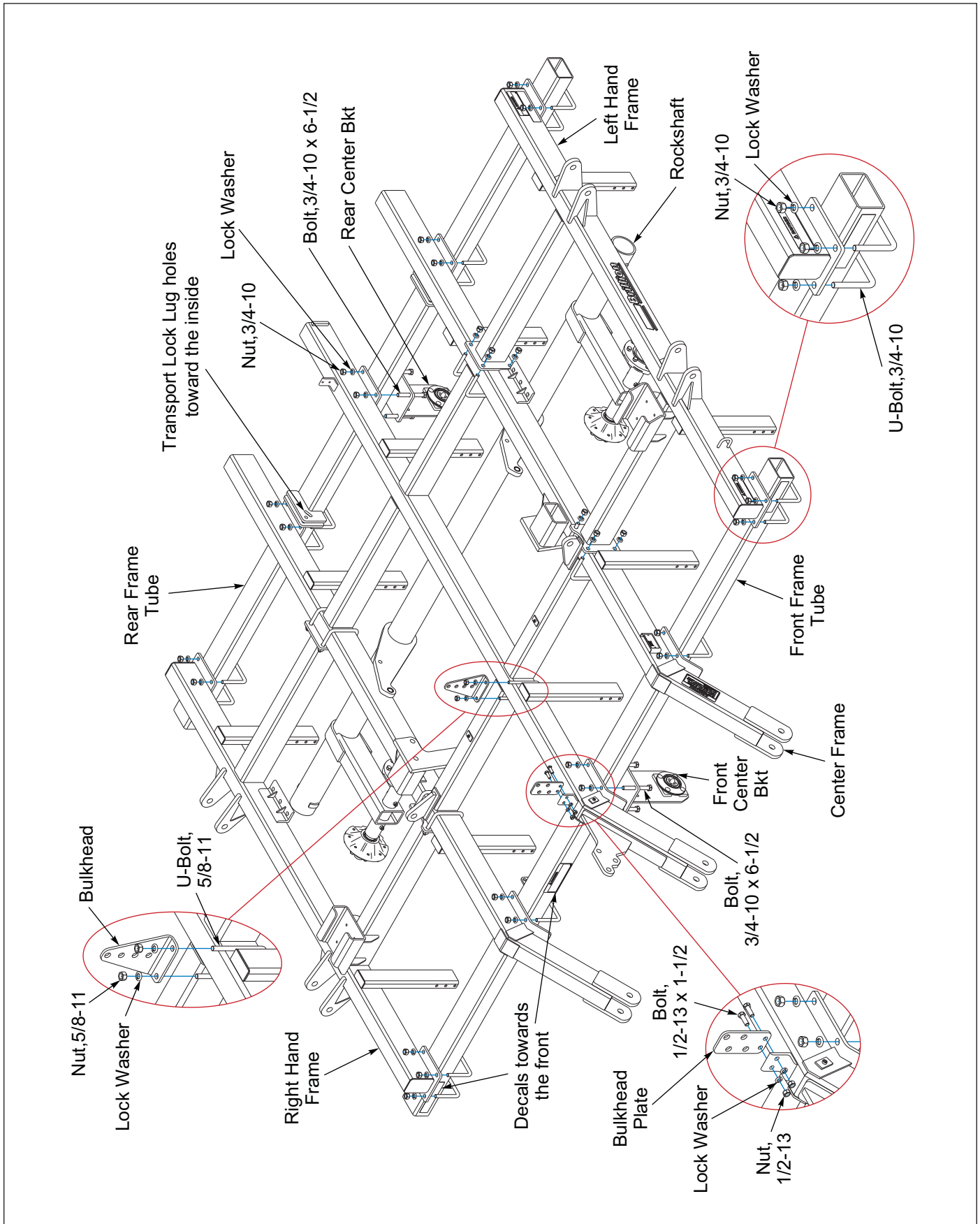

Figure 2-1: Frame Assembly

Frame Assembly Dimensions

NOTE

"Left" and "Right" refer to directions seen as if standing behind the machine and facing in the direction of forward travel.

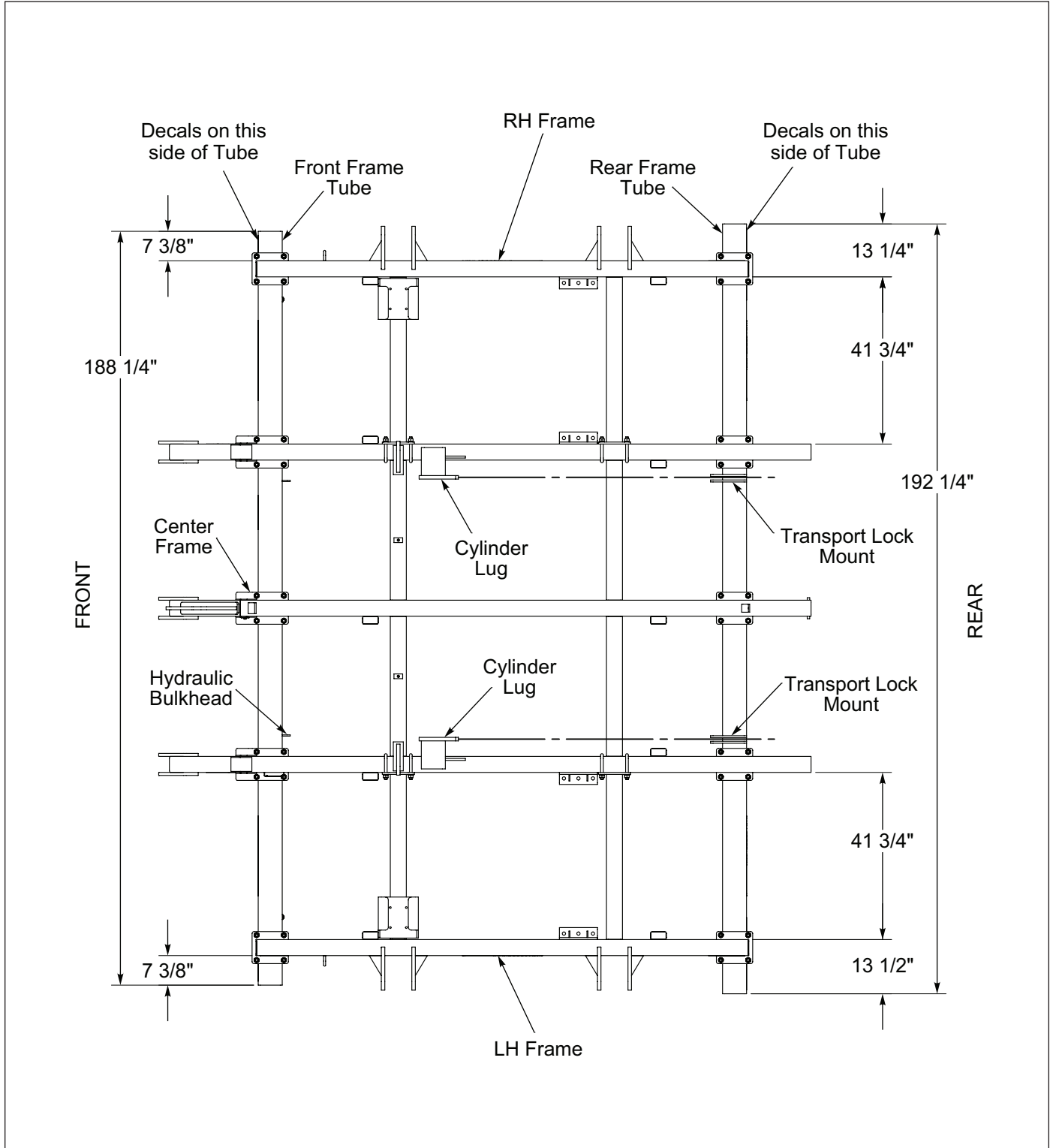

Figure 2-2: Frame Assembly Dimensions

Center Bearing Brackets Offset

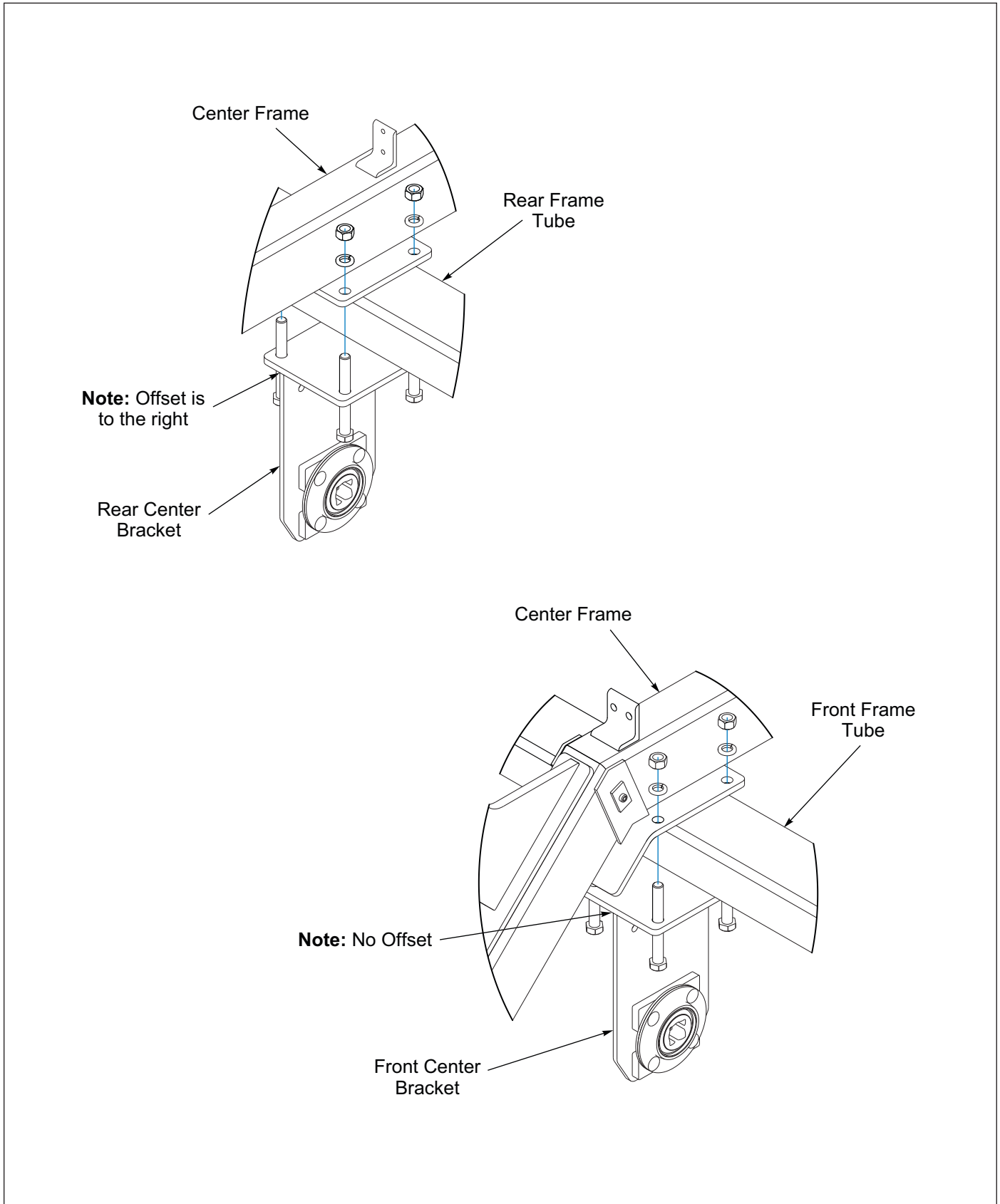

Figure 2-3: Center Bearing Brackets Offset

Rockshaft Installation

1. Take the bearing castings and insert the straight and angled grease fittings to create a set of four bearings. Coat the curved portion of each bearing with a thick coat of grease. Install the rockshaft by fitting the bearing sets around the rockshaft, with the straight grease fittings on top, attach them to the underside of the angle pads welded to the Frame Tubes, with 3/4-10 x 9 Bolts, Lock Washers and Nuts.

2. Attach the Transport Locks to the Rockshaft Lug using 3/4 x 2-3/4 Clevis Pin, Flat Washers and 1/8 x 1-1/4 Cotter Pin. Place the other end between the Rear Frame Tube Lugs using 5/8 x 2-1/2 Clevis Pin, Flat Washers and Hair Pin Cotter. The hole is the storage position and the slot is the locked position.

3. Install the two 4 x 16 Hydraulic Cylinders by attaching the cylinder base to the cross member lug and secure with hardware provided.

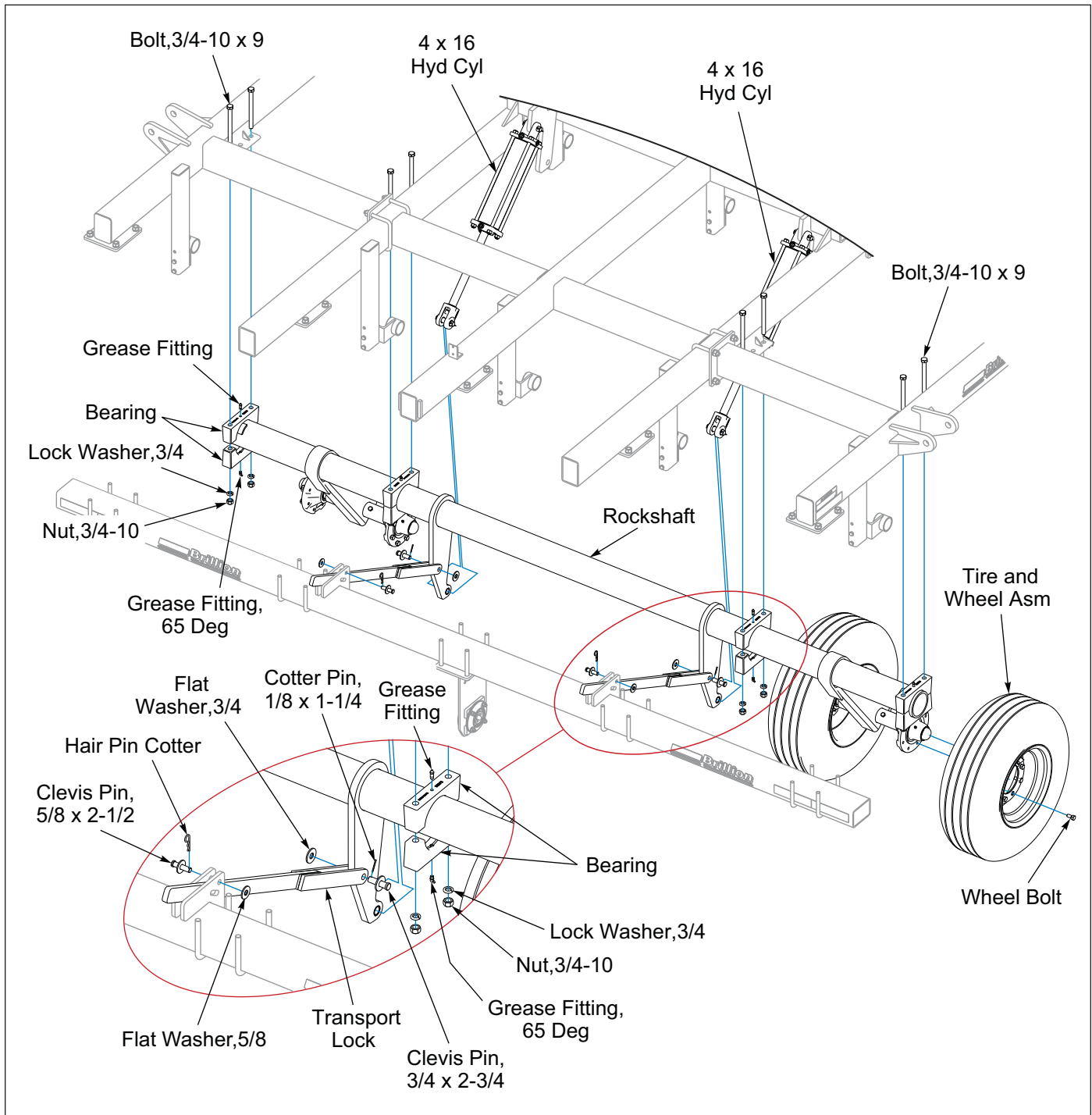

Figure 2-4: Rockshaft Installation

Tire Installation



WARNING

Use a torque wrench to assure proper torque. Insufficient torque can cause stud breakage and damage the wheel pilots. Over torque can overstress the studs and strip the threads.

NOTE

All Tire/Wheel Assemblies are mounted with the Valve Stem facing outward from Hub and Spindle.

1. Remove the eight 9/16-18 Wheel Bolts from the Hub. Install the tire and wheel assembly onto the hub. The W360 Pulvi-Mulcher uses 12.5L x 16 - 14 ply tires and should be inflated to 50 PSI.
2. Re-Install the Wheel Bolts and tighten to 50 foot-pounds using the sequence in **Figure 2-5**. Then tighten to full torque of 90-100 ft-lbs. It is good maintenance practice to lubricate the wheel bolts prior to inserting.

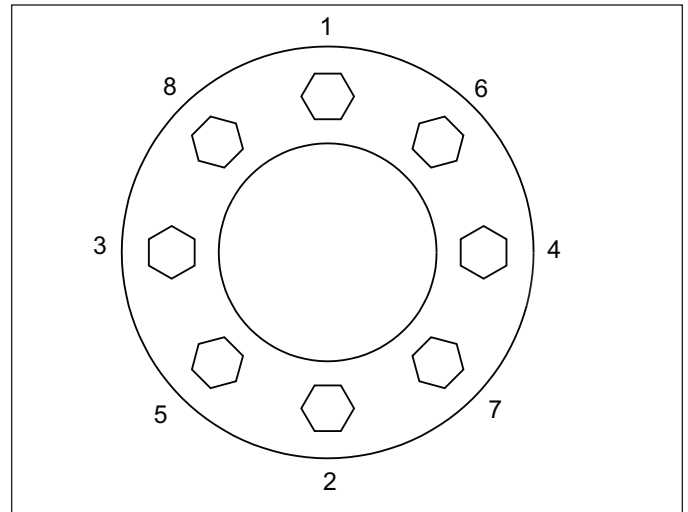

Figure 2-5: Stud Tightening Sequence

NOTE

Torque will drop after the first 10 hours of operation. Check the nuts for proper torque after this interval and re-tighten them.

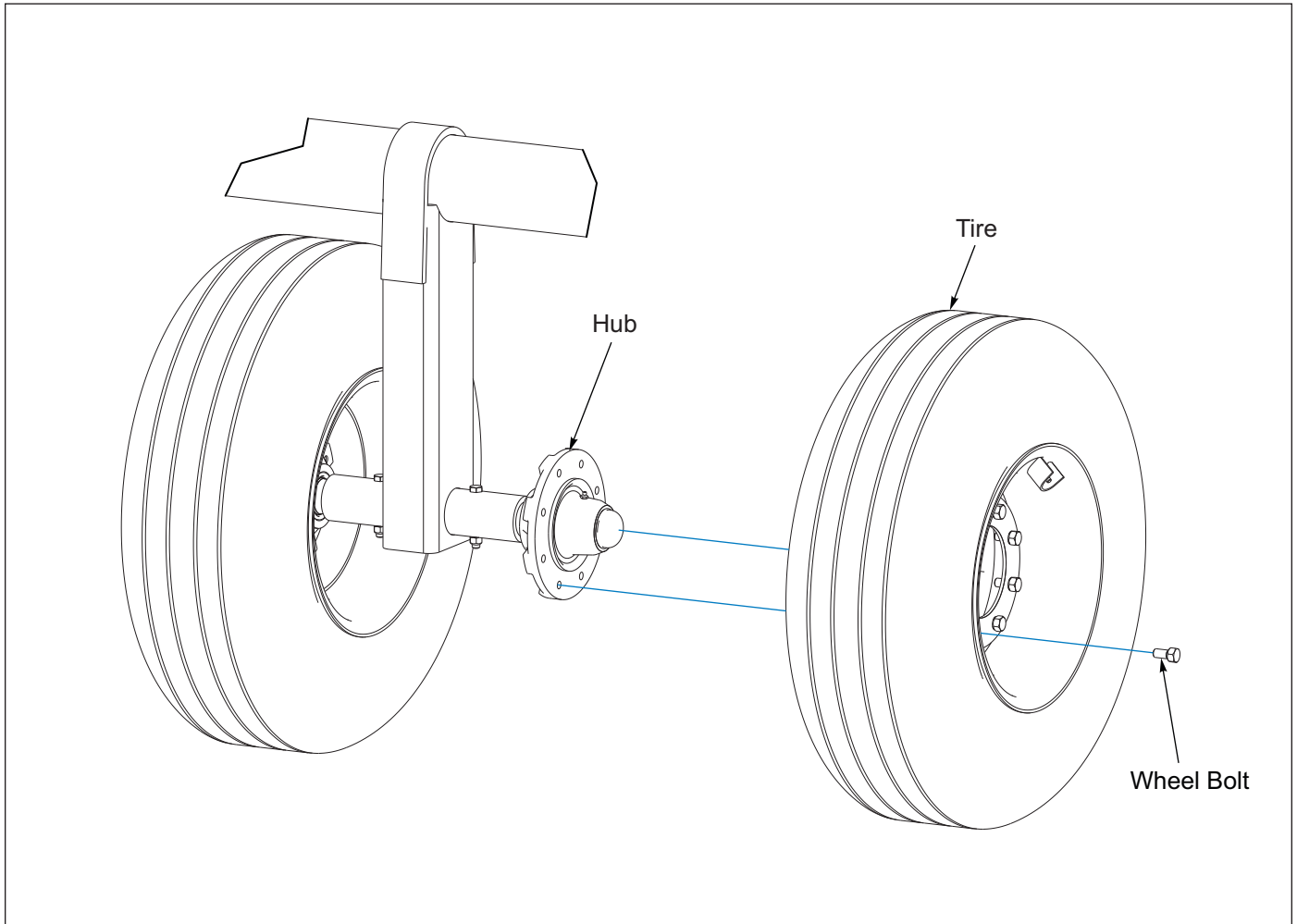

Figure 2-6: Tire Installation

Drawbar and Transport Lock Installation

1. Position Drawbar with the decal on top. Attach to the three inner frame tubes using 1-1/4 x 8-3/4 Pin, Flat Washer and Slotted Pin.
2. Attach the Safety Chain with 1-8 x 3-1/2 Bolt, Flat Washers and Locknut.
3. Install the Hitch using the 1-1/4-7 x 9-1/2 Bolt and Locknut.
4. Attach the Hose Support with 5/8-11 x 2 Bolt, Flat Washer, Lock Washer and Nut.
5. Attach the Drawbar Jack to the Jack Swivel on the inside of the Drawbar and secure with attached pin.
6. Mount the Manual Canister to the Instruction Tube Bracket located on inside Left Drawbar Tube and secure using two Hose Clamps.
7. Insert the Float Link between the two Drawbar Lugs on the top of the Rear Tube.
8. Place the two Side Plates, single hole end on the outside of the Float Link, slide Clevis Pin through the holes secure with Flat Washer and 3/16 x 1-1/2 Cotter Pin.
9. On the two hole end of the Side Plates, position Tie Bar between and line up both holes, slide Clevis Pins through the holes secure bottom hole with Flat Washer and 3/16 x 1-1/2 Cotter Pin. Secure top hole with Flat Washer and Hair Pin Cotter, which is the Transport Lock. When the machine is not in transport position the Clevis Pin should be stored in the storage hole located at the top of the Center Frame Cylinder Frame Lug.
10. Attach Tie Bar to Center Frame Cylinder Lug lower hole. Secure using Clevis Pin, Flat Washer and 3/16 x 1-1/2 Cotter Pin.
11. Attach base end of 3 x 6 Hydraulic Cylinder to Center Frame Cylinder Lug top hole. Attach the rod end of cylinder to the front hole on the Float Link and secure with existing hardware.
12. Check to ensure there is no binding.

TABLE OF CONTENTS

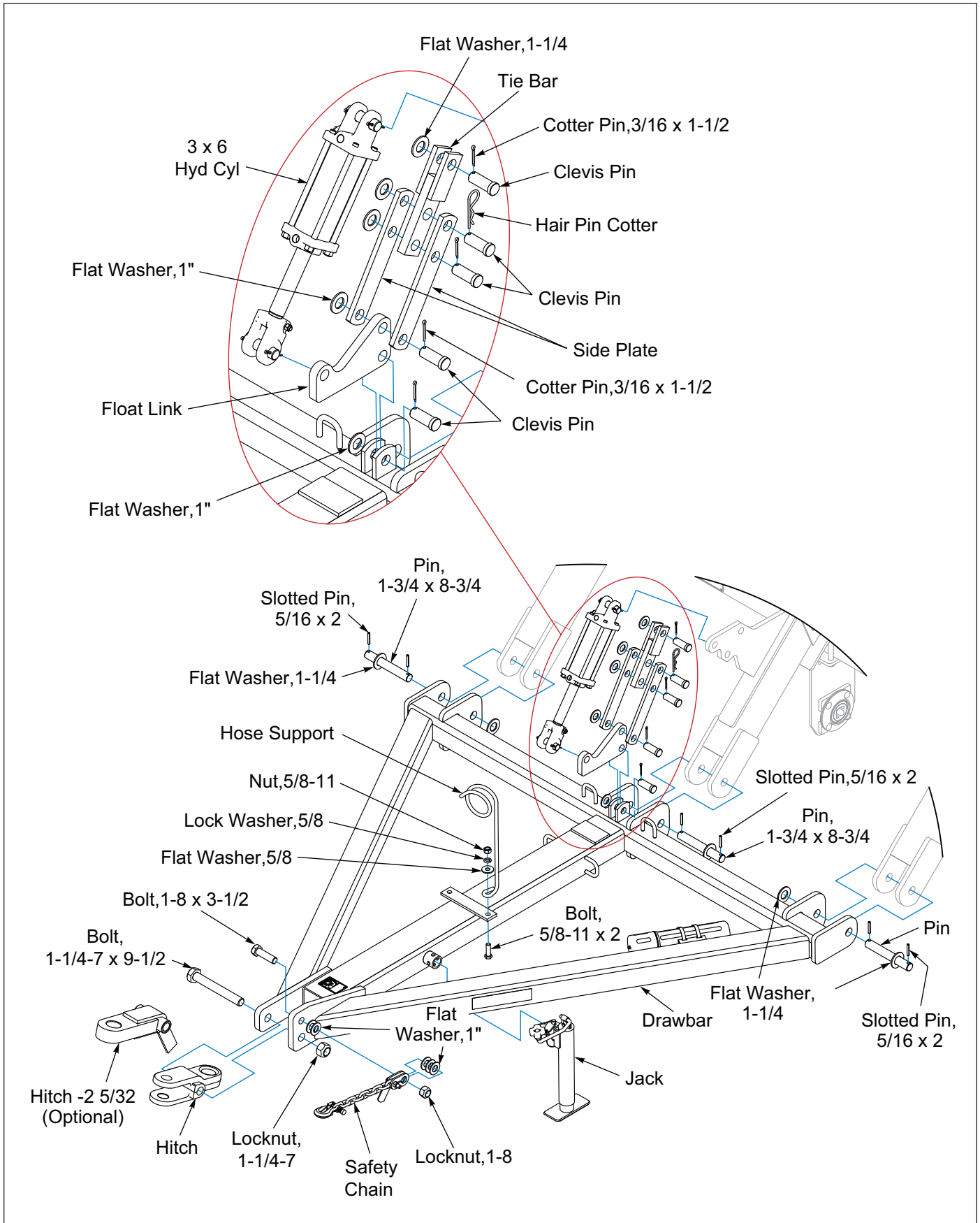

Figure 2-7: Drawbar and Transport Lock Installation

Tooth Tube Bracket Assembly

S-Tine Machines:

Assemble five 9J091 S-Tine Brackets to the front vertical tube supports top and middle holes using 1/2-13 X 5 Bolts and Locknuts. On the rear vertical tube supports top and middle holes assemble five 9J091 S-Tine Brackets and Spacers using 1/2-13 X 6-1/2 Bolts and Locknuts. **See Figure 2-8.**

C-Tooth Machines:

Assemble ten 9J090 C-Tooth Brackets to the front and rear vertical middle and bottom holes tube supports using 1/2-13 X 5 Bolts and Locknuts. **See Figure 2-9.**

Figure 2-10 shows the proper positioning of these brackets when assembled. The brackets must be assembled exactly as shown in the illustration. (Reversing some of these brackets will cause interference later when mounting spring teeth.)

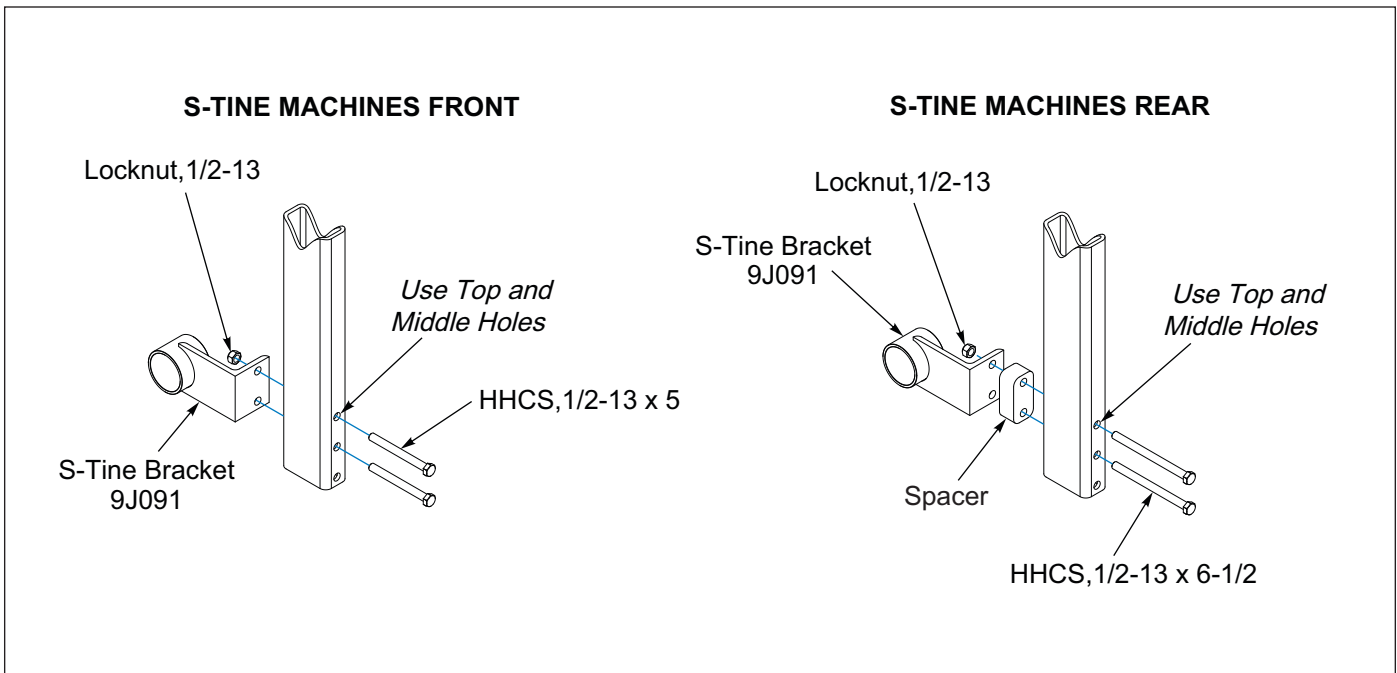

Figure 2-8: S-Tine Bracket Assembly

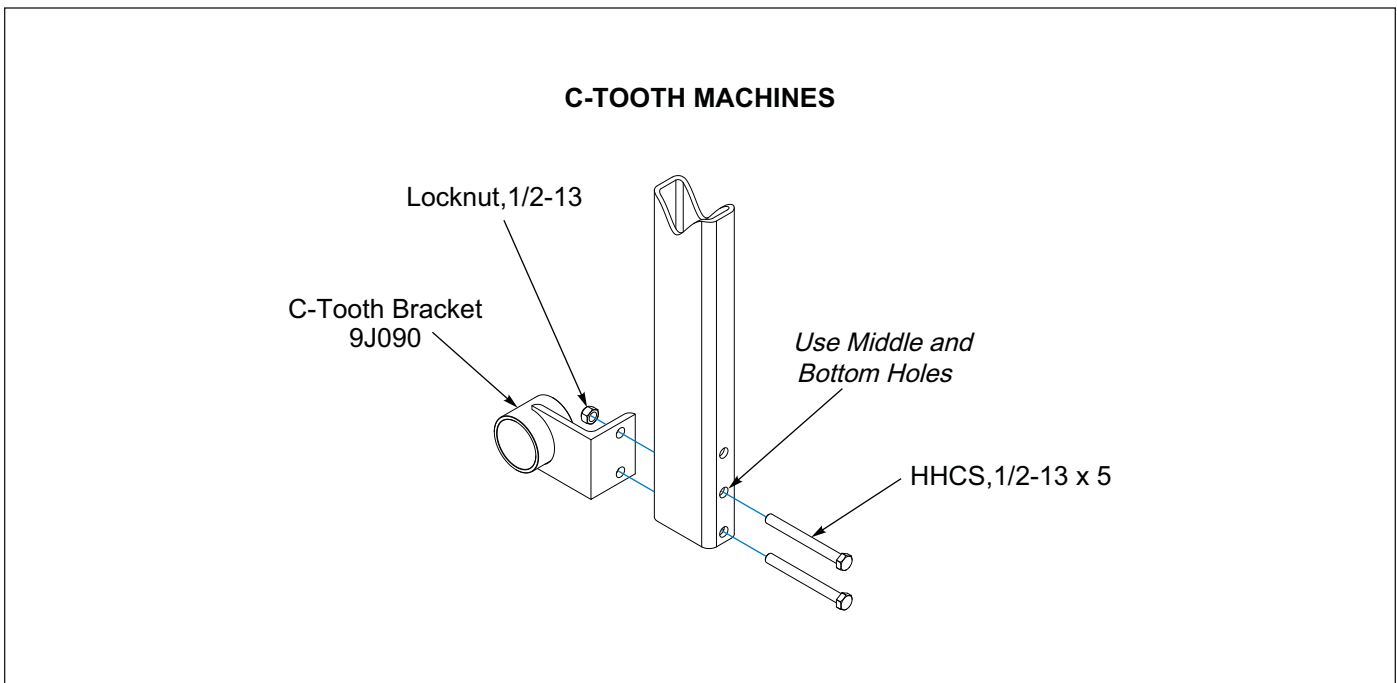

Figure 2-9: C-Tooth Bracket Assembly

Center Frame Tooth Bracket Locations

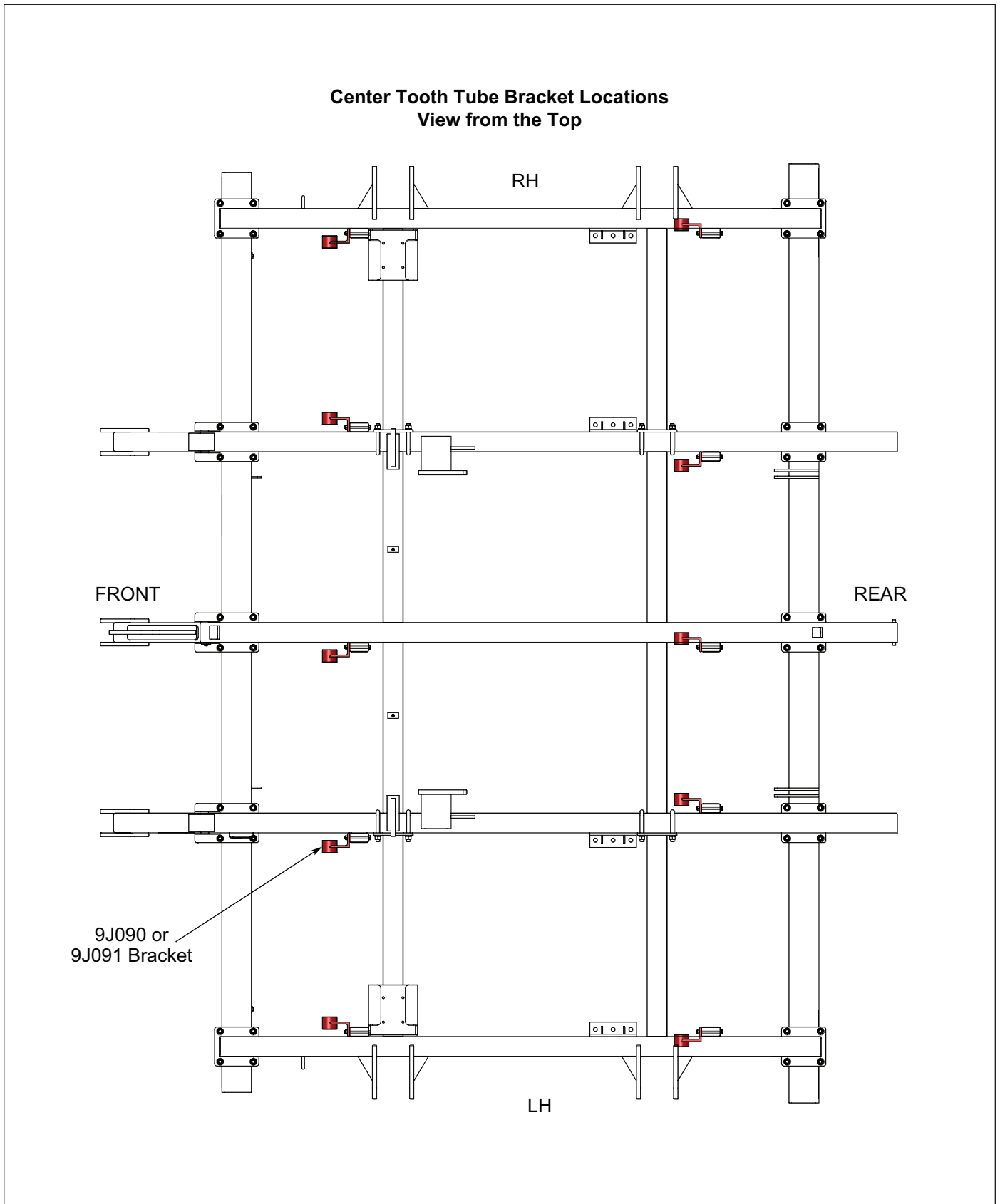

Figure 2-10: Center Frame Tooth Bracket Locations

Tooth or Tine Installation

1. Assemble all brackets and pencil mark the tooth locations on the tooth tubes. Measure each of the tooth tubes for proper placement of each tube.
2. Slide the tooth tubes through the Tooth Tube Brackets from their respective sides and position such that the left and right tubes meet in the center of the Center Tooth Tube Bracket. **See Figure 2-12.**
3. Fix the tooth tubes in place by assembling Clamp Straps on the inside of the each outer Tooth Tube Bracket. Secure with 1/2-13 U-Bolts, Lock Washers and Nuts. **See Figure 2-11.**

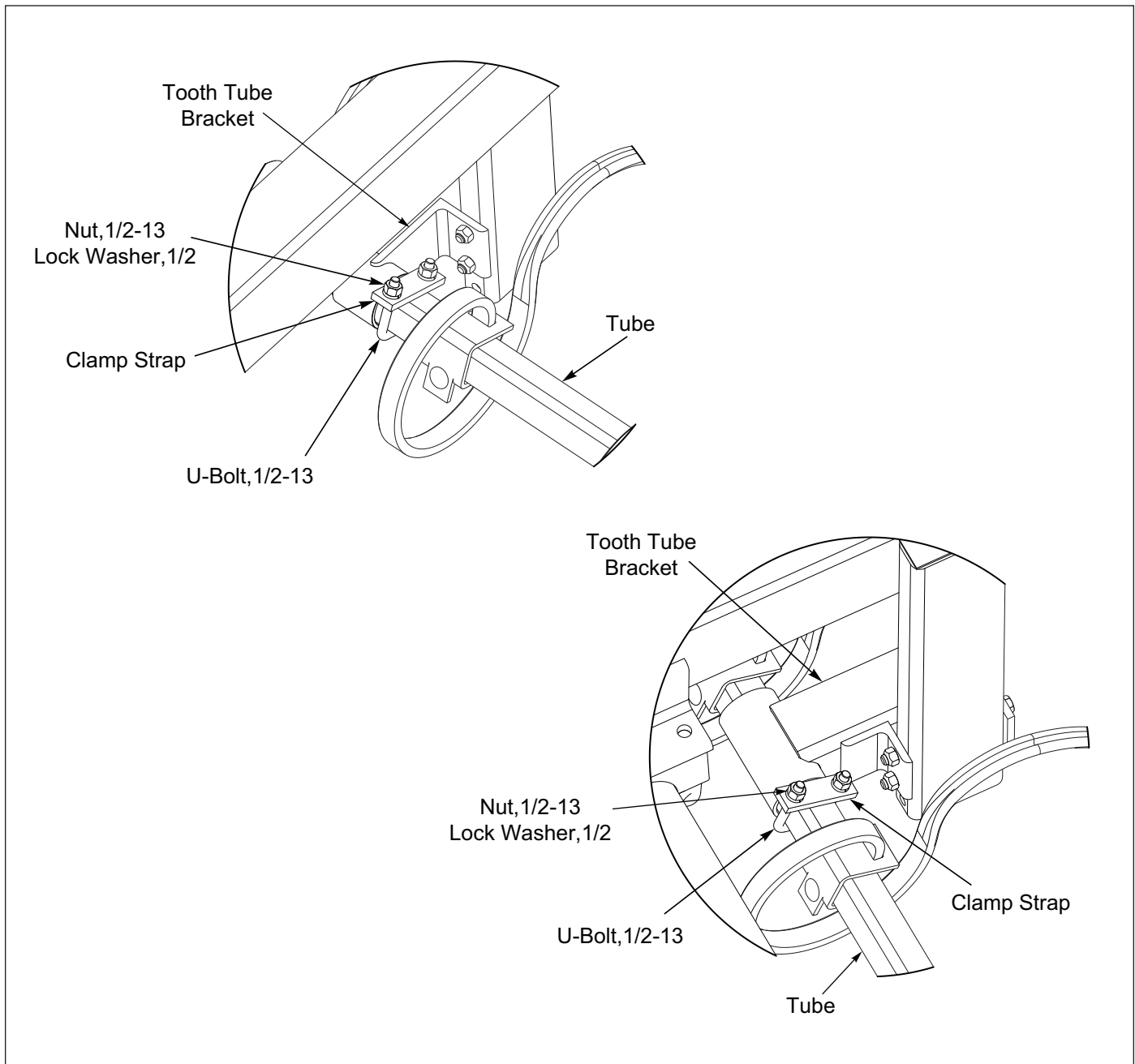

Figure 2-11: Fixing the Tubes in Place

Center Frame Tooth Locations

Pencil mark the Tooth Locations on the Tubes.

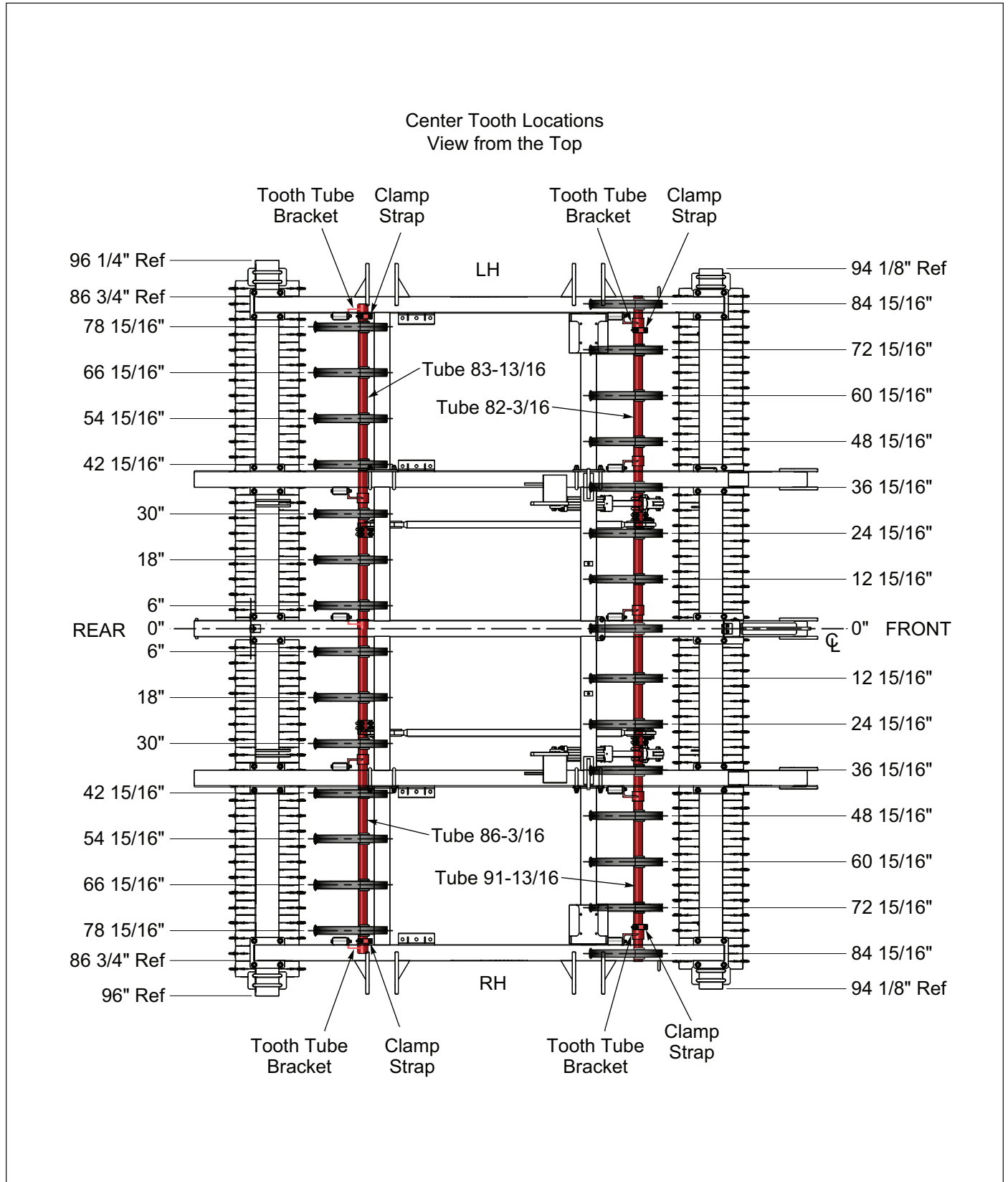

Figure 2-12: Center Frame Tooth Locations

Center Frame S-Tine Installation

Tooth locations are shown in **Figure 2-12**. For ease of installation, assemble points with 3/8-16 Cultivator Bolts and Locknuts to spring tines before mounting onto tooth tubes. **See Figure 2-14**. Install 15 teeth on the front tube and 14 on the rear as shown in **Figure 2-13**.

1. Attach the Right Hand and Left Hand Control Arms to the Front Tubes using 5/8-11 U-Bolts, Lock Washers and Nuts. Repeat for the Rear Tubes. **See Figure 2-15**.
2. Attach the Cylinder Arms to the Front Tube using 5/8-11 U-Bolts, Lock Washers and Nuts.
3. Connect the Front and Rear Tubes by placing the Link Assembly onto the Control Arms. On the Front Tube place a 3/4 Flat Washer on each side of the Control Arm Lug, slide 3/4 x 2-3/4 Clevis Pin through, place four 3/4 Flat Washers on the Pin and insert 1/8 x 1-1/4 Cotter Pin.
4. On the Rear Tube place a 3/4 Flat Washer on each side of the Control Arm Lug, place one 3/4 Flat Washer onto the 3/4 x 2-3/4 Clevis Pin then slide through, place three 3/4 Flat Washers on the Pin and insert 1/8 x 1-1/4 Cotter Pin.
5. Check to ensure there is no binding and no interference with the Tines.
6. Attach the 3 x 8 Hydraulic Cylinders to the Front Tubes using Pins provided.

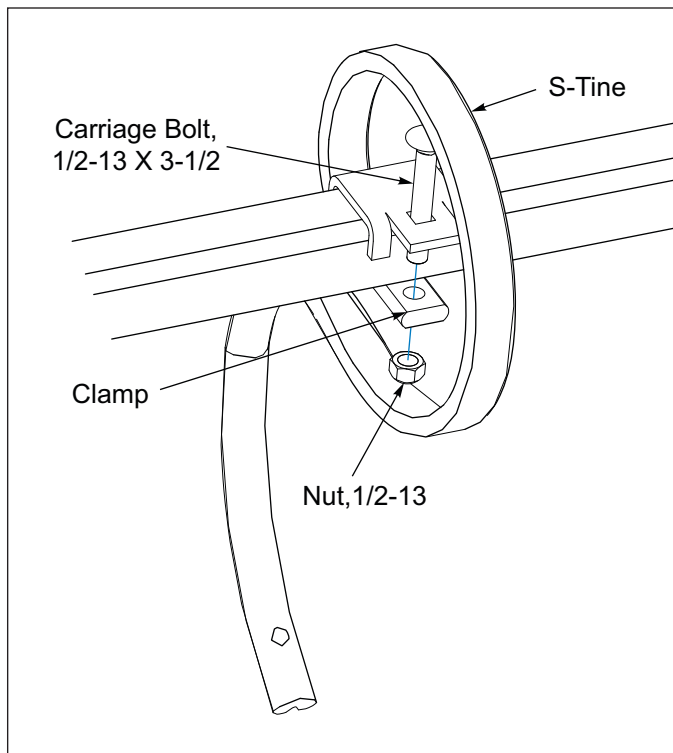

Figure 2-13: S-Tine Installation

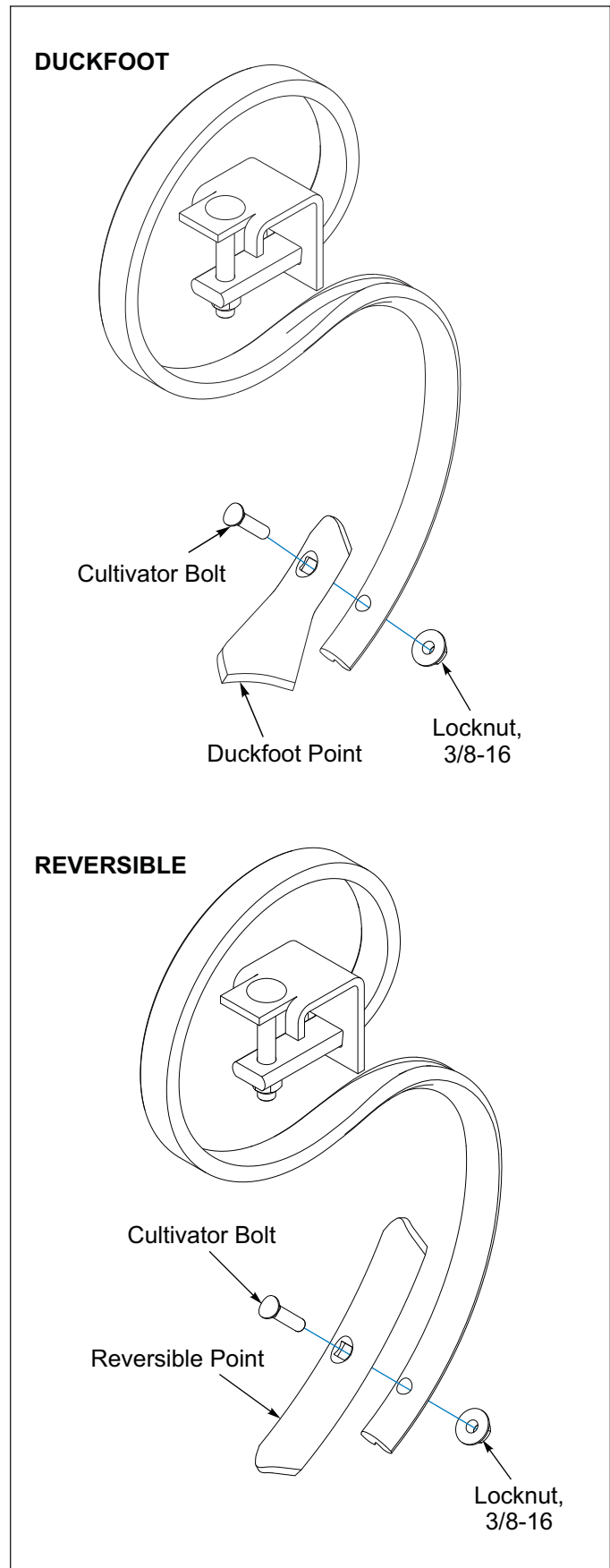

Figure 2-14: S-Tine Points

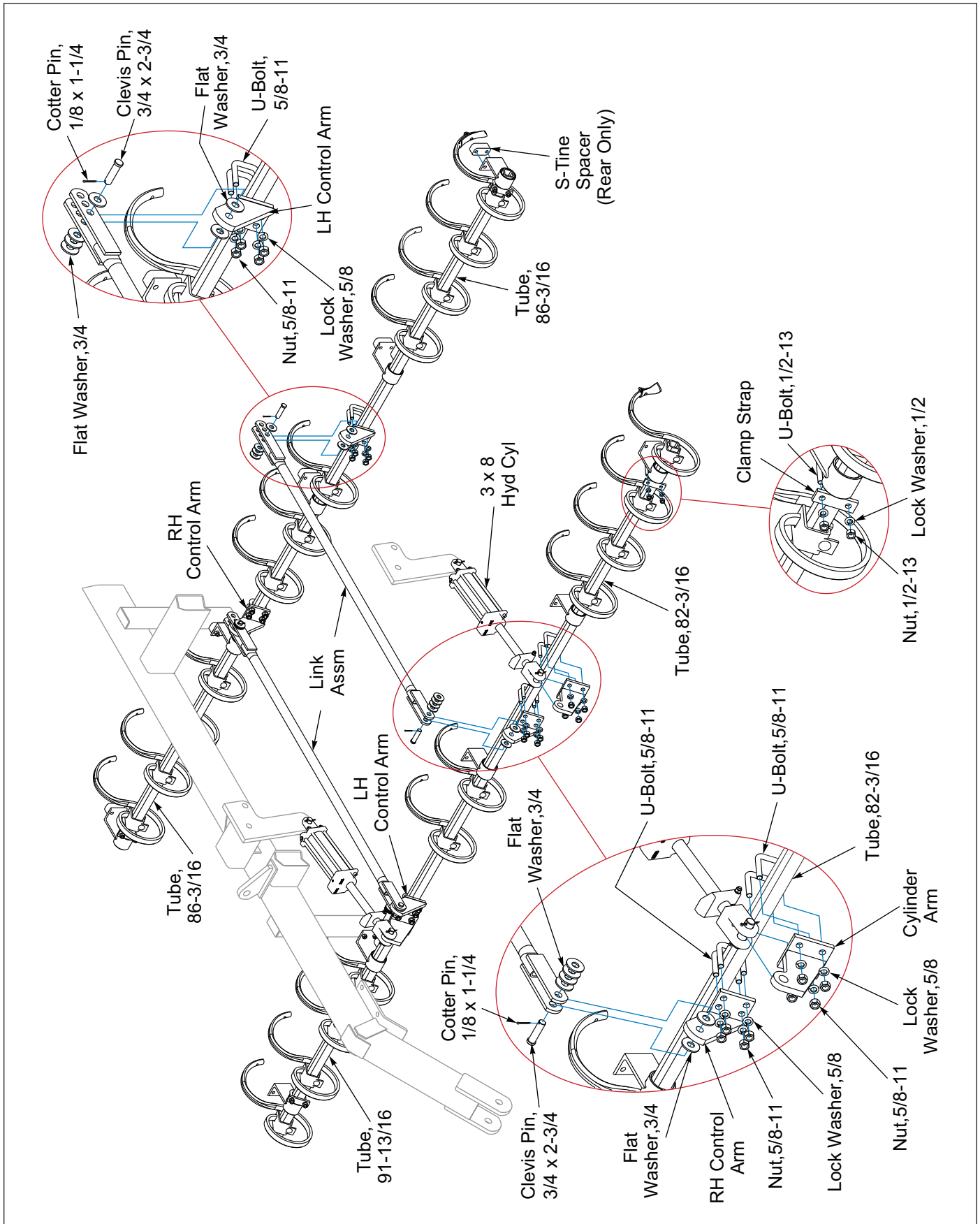

Figure 2-15: Center Frame S-Tine Installation

Center Frame C-Tooth Installation

1. Tooth locations are shown in **Figure 2-12**. Put 15 Teeth on the front tube and 14 on the rear as shown in **Figure 2-16**.
2. Attach the Control Arms to the Front Tubes using 5/8-11 U-Bolts, Lock Washers and Nuts. Repeat for the Rear Tubes. **See Figure 2-17**.
3. Attach the Cylinder Arms to the Front Tube using 5/8-11 U-Bolts, Lock Washers and Nuts.
4. Connect the Front and Rear Tubes by placing the Link Assembly onto the Control Arms. On the Front Tube place a 3/4 Flat Washer on each side of the Control Arm Lug, slide 3/4 x 2-3/4 Clevis Pin through, place four 3/4 Flat Washers on the Pin and insert 1/8 x 1-1/4 Cotter Pin.
5. On the Rear Tube place a 3/4 Flat Washer on each side of the Control Arm Lug, place one 3/4 Flat Washer onto the 3/4 x 2-3/4 Clevis Pin then slide through, place three 3/4 Flat Washers on the Pin and insert 1/8 x 1-1/4 Cotter Pin.
6. Check to ensure there is no binding and no interference with the Tines.
7. Attach the 3 x 8 Hydraulic Cylinders to the Front Tubes using Pins provided.

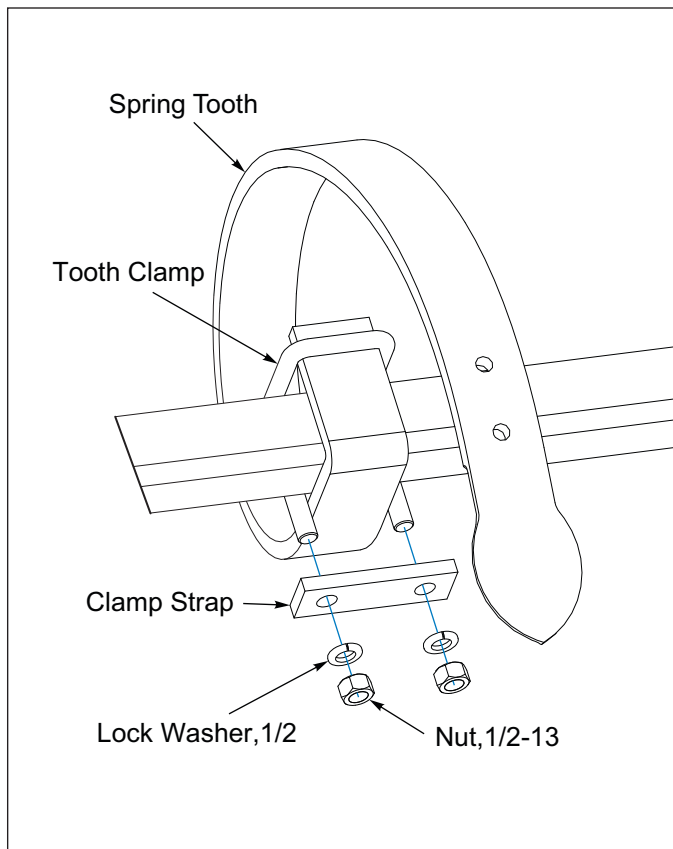

Figure 2-16: C-Tooth Installation

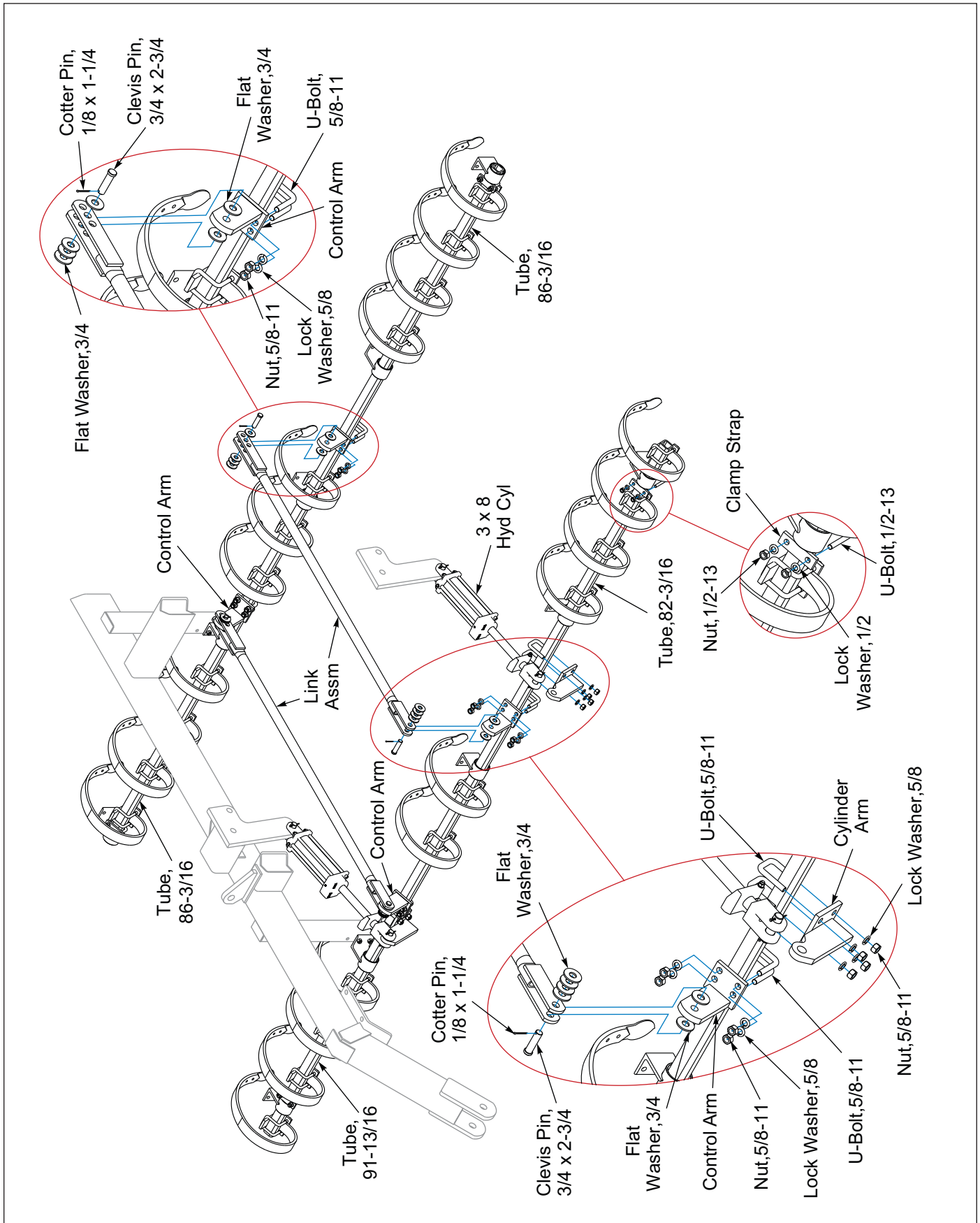

Figure 2-17: Center Frame C-Tooth Installation

Wing Hinge and Fold Cylinder Installation



WARNING

Do not attempt to lift heavy parts (such as the frame, rockshaft, and pull hitch) manually. Use a hoist or a fork lift to move these parts into position.

1. Attach the base end of a 4 x 24 Hydraulic Cylinder to the left and right side Center Frame Lugs with Pins provided. The rod end must face outward and ports must face the rear of the machine. **See Figure 2-18.**
2. Align the Top Hole of the Wing Frame Hinge Lug with the Center Frame Hinge Lug. Secure with 1-1/4 x 10 Pin, 1-1/4 Flat Washer and 5/16 x 2 Roll Pin.
3. Take four 1-1/4 x 8-3/4 Pins, insert 5/16 x 2 Roll Pin into one end, set aside.
4. Align the two Links with cutout downward and facing outward on the inside of the Wing Frame Hinge Lug Holes. Place Bushing with a 1-1/4 Flat Washer on each end between the Links. Install two 1-1/4 Flat Washers onto previously set aside 1-1/4 x 8-3/4 Pin. Slide Pin through Wing Hinge Lug Holes, Links, Lock Washers and Bushing. Place two 1-1/4 Flat Washers on Pin. Secure with 5/16 x 2 Roll Pin.
5. Slide a 1-1/4 Flat Washer, Roller Assm and two 1-1/4 Flat Washers onto previously set aside 1-1/4 x 8-3/4 Pin. Align Cylinder Rod end with 1-1/4 Flat Washers on each side with the two Links. Slide Pin through and place a 1-1/4 Flat Washer, Roller Assm and two 1-1/4 Flat Washers on end of Pin. Secure with 5/16 x 2 Roll Pin.

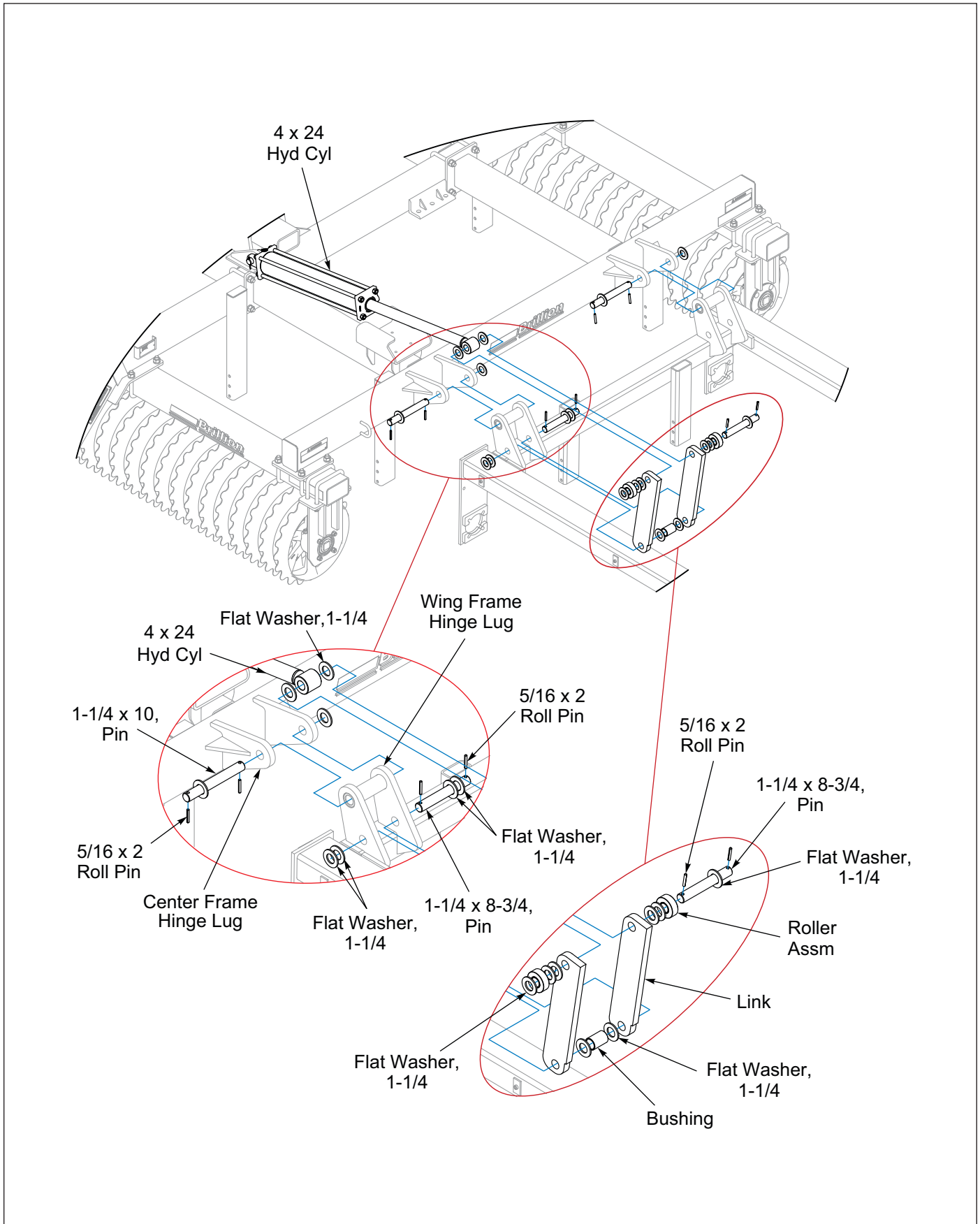

Figure 2-18: Wing Hinge and Fold Cylinder Installation

Wing Tooth Tube Bracket Assembly

S-Tine Machines

Assemble two 9J091 S-Tine Brackets to the front vertical tube supports top and middle holes using 1/2-13 X 5 Bolts and Locknuts. On the rear vertical tube supports top and middle holes assemble two 9J091 S-Tine Brackets and Spacers using 1/2-13 X 6-1/2 Bolts and Locknuts. **See Figure 2-8.**

C-Tooth Machines

Assemble four 9J090 C-Tooth Brackets to the front and rear vertical middle and bottom holes tube supports using 1/2-13 X 5 Bolts and Locknuts. **See Figure 2-9.**

Figure 2-19 shows the proper positioning of these brackets when assembled. The brackets must be assembled exactly as shown in the illustration. (Reversing some of these brackets will cause interference later when mounting spring teeth.)

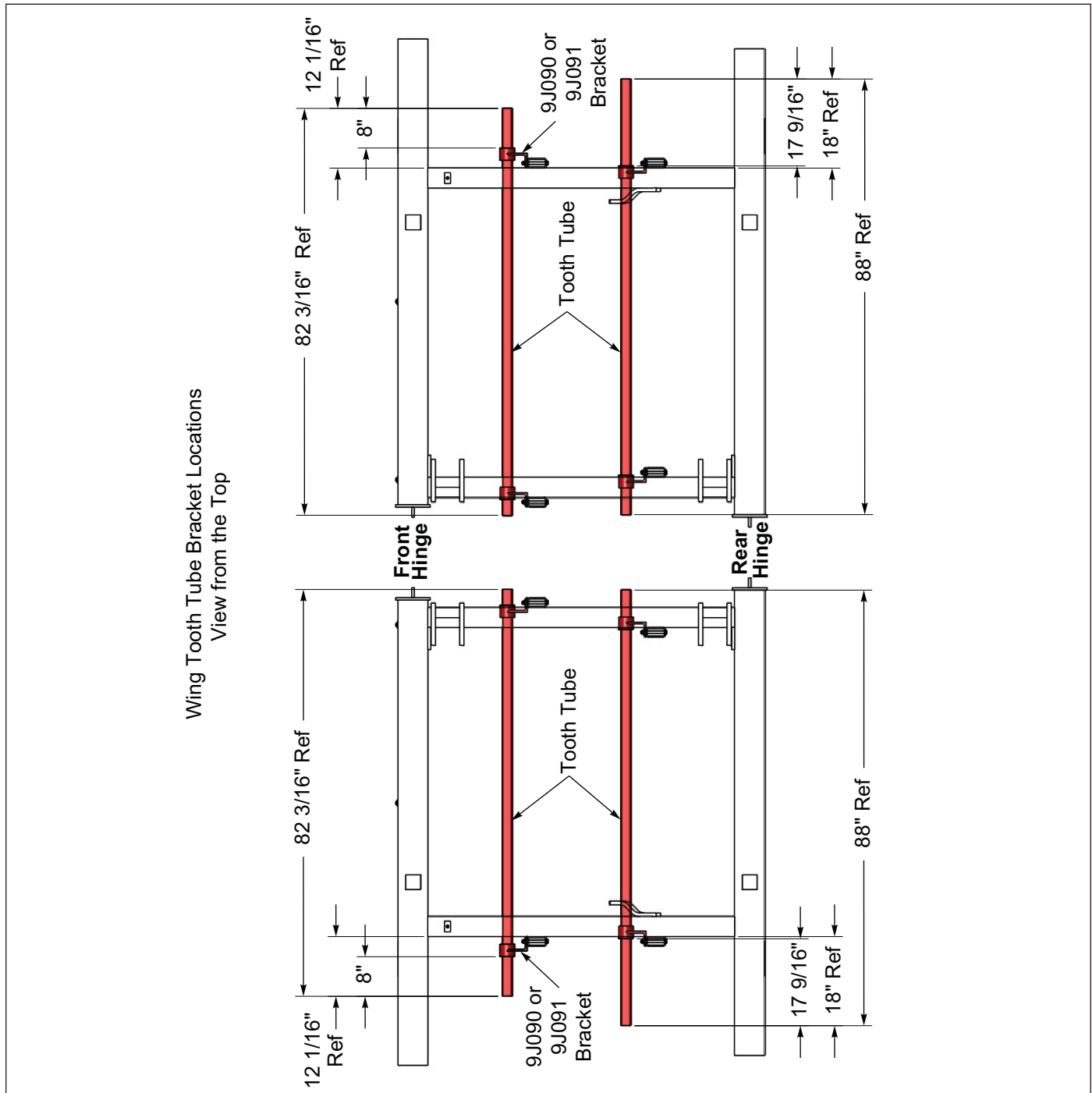

Figure 2-19: Wing Tube Bracket Locations

Wing Frame Tooth Locations

1. Assemble all brackets and pencil mark the tooth locations on the tooth tubes. Measure each of the tooth tubes for proper placement of each tube.
2. Slide the tooth tubes through the Tooth Tube Brackets. **See Figure 2-20.**
3. Fix the tooth tubes in place by assembling Clamp Straps on the outside of each front tooth tube bracket and on the inside of each rear tooth tube bracket. Secure with 1/2-13 U-bolts, Lock Washers and Nuts. **See Figure 2-11.**

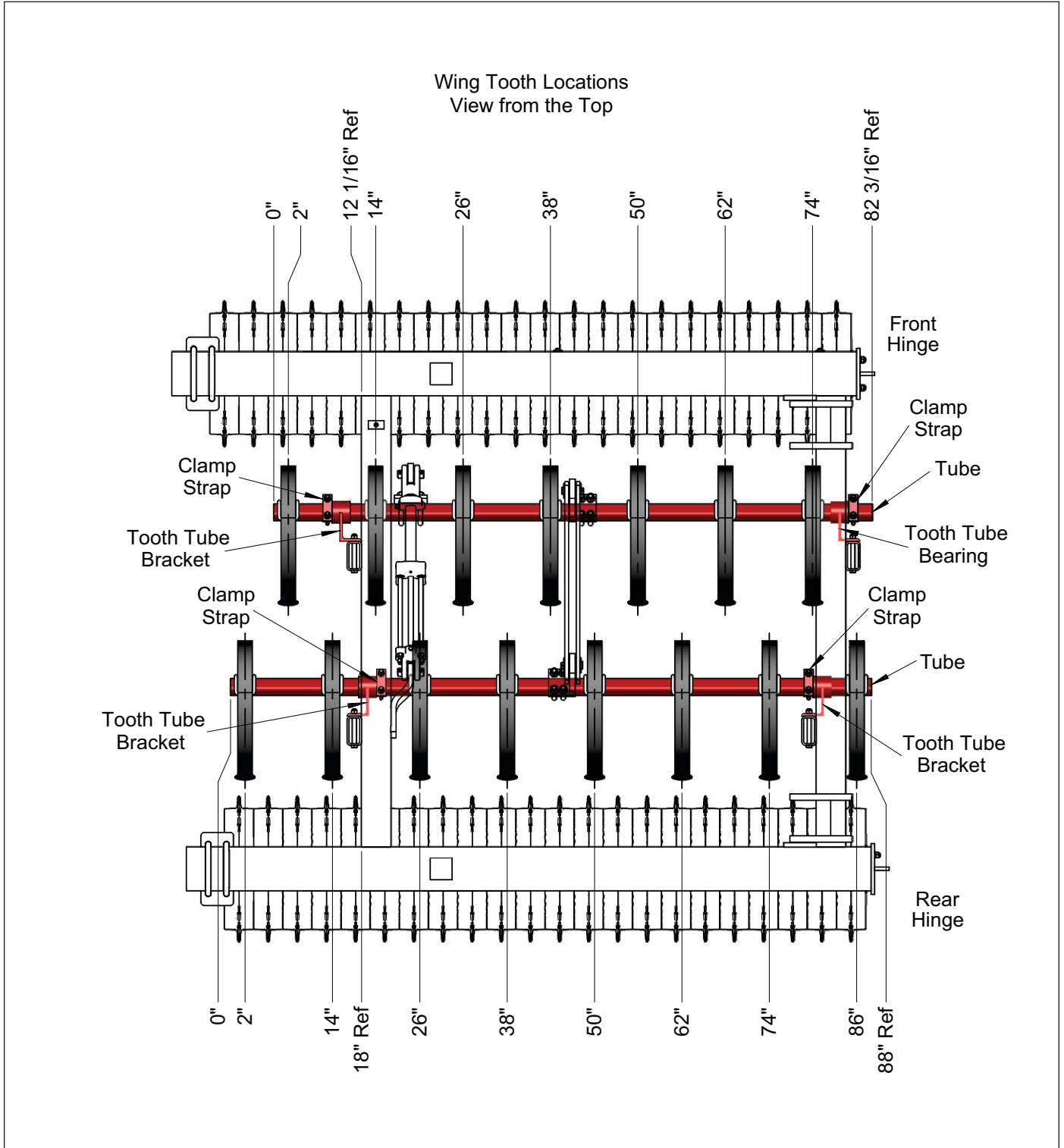

Figure 2-20: Wing Frame Tooth Locations

Wing Frame S-Tine Installation

1. Tooth locations are shown in **Figure 2-20**. For ease of installation, assemble points with 3/8-16 Cultivator Bolts and Locknuts to spring tines before mounting onto tooth tubes. **See Figure 2-14**. Install 7 Teeth on the front tube and 8 on the rear as shown in **Figure 2-21**.
2. Attach the Left Hand Control Arm to the Front Tube using 5/8-11 U-Bolts, Lock Washers and Nuts. Attach the Right Hand Control Arm to the Rear Tube using 5/8-11 U-Bolts, Lock Washers and Nuts.
3. Attach the Cylinder Arm to the Front Tube using 5/8-11 U-Bolts, Lock Washers and Nuts.
4. Connect the Front and Rear Tubes by placing two Straps onto the Control Arms. Place a 3/4 Flat Washer on each side of the Control Arm Lug, place one 3/4 Flat Washer onto the 3/4 x 2-3/4 Clevis Pin then slide through, place a 3/4 Flat Washer on and insert 1/8 x 1-1/4 Cotter Pin.
5. Check to ensure there is no binding and no interference with the Tines.
6. Attach the 3 x 8 Hydraulic Cylinder to the Front Tube using Pins provided.

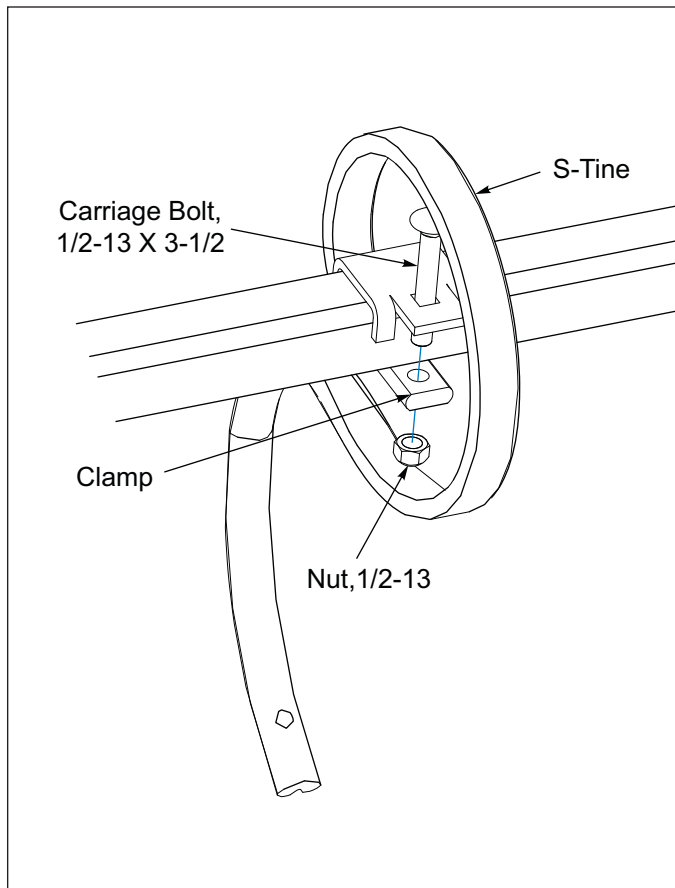

Figure 2-21: S-Tine Installation

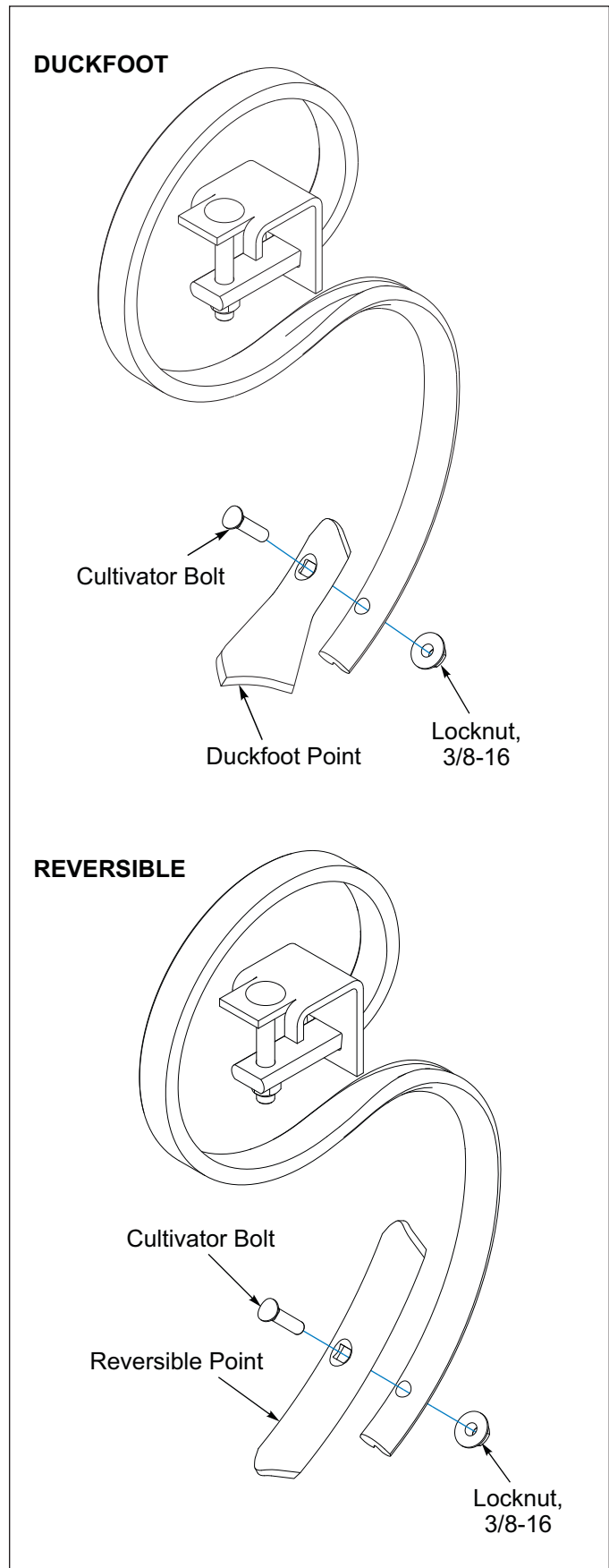

Figure 2-22: S-Tine Points

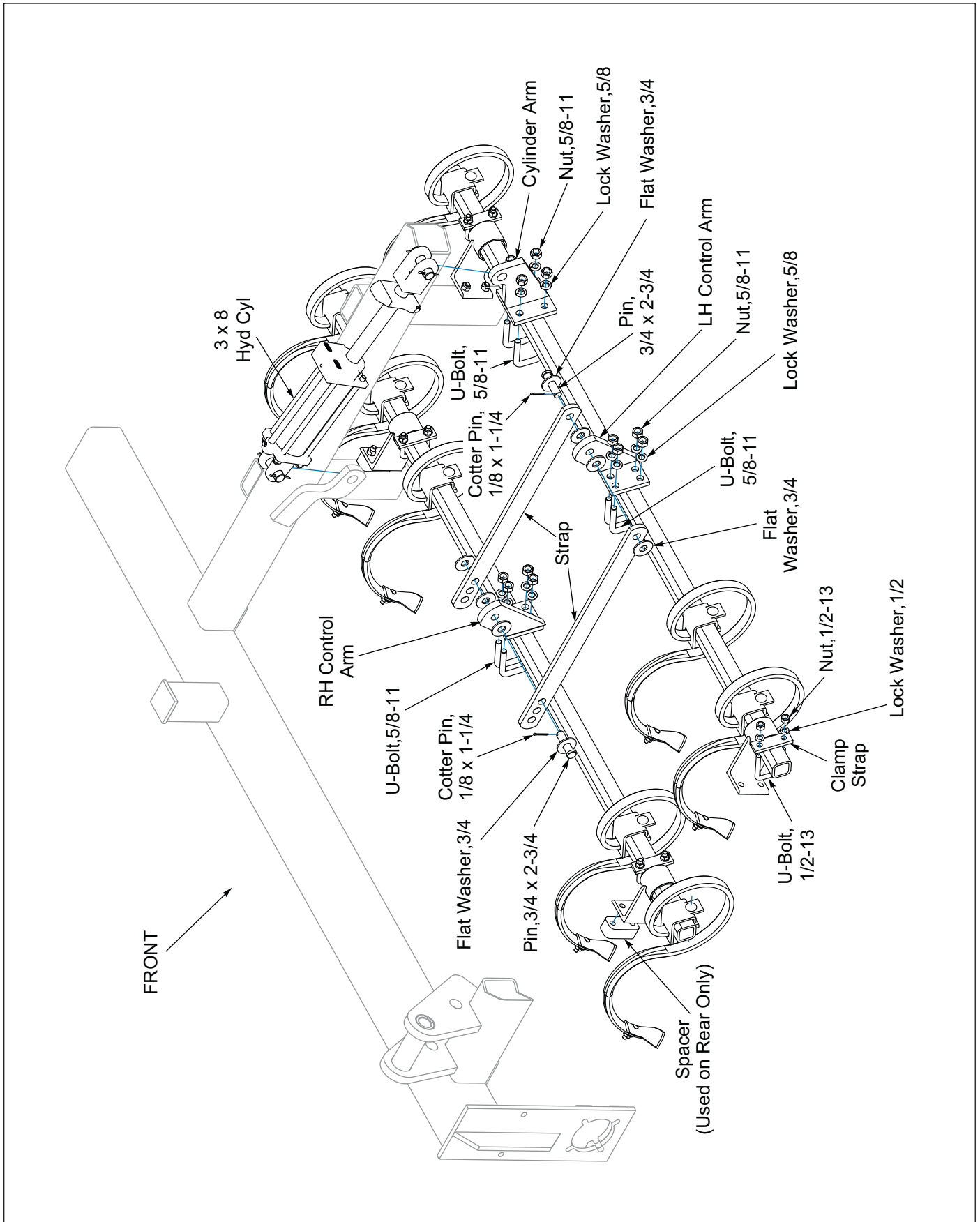

Figure 2-23: Wing Frame S-Tine Installation

Wing Frame C-Tooth Installation

1. Tooth locations are shown in **Figure 2-20**. Install 7 Teeth on the front tube and 8 on the rear as shown in **Figure 2-16**.
2. Attach the Control Arms to the Front Tubes using 5/8-11 U-Bolts, Lock Washers and Nuts. Repeat for the Rear Tubes. **See Figure 2-24**.
3. Attach the Cylinder Arm to the Front Tube using 5/8-11 U-Bolts, Lock Washers and Nuts.
4. Connect the Front and Rear Tubes by placing two Straps onto each side of the Front and Rear Control Arms. Slide a 3/4 Flat Washer on each side of the Control Arm Lug, place one 3/4 Flat Washer onto the 3/4 x 2-3/4 Clevis Pin then slide through, place a 3/4 Flat Washer on Pin and insert 1/8 x 1-1/4 Cotter Pin.
5. Check to ensure there is no binding and no interference with the Tines.
6. Attach the 3 x 8 Hydraulic Cylinder to the Front Tube using Pins provided.

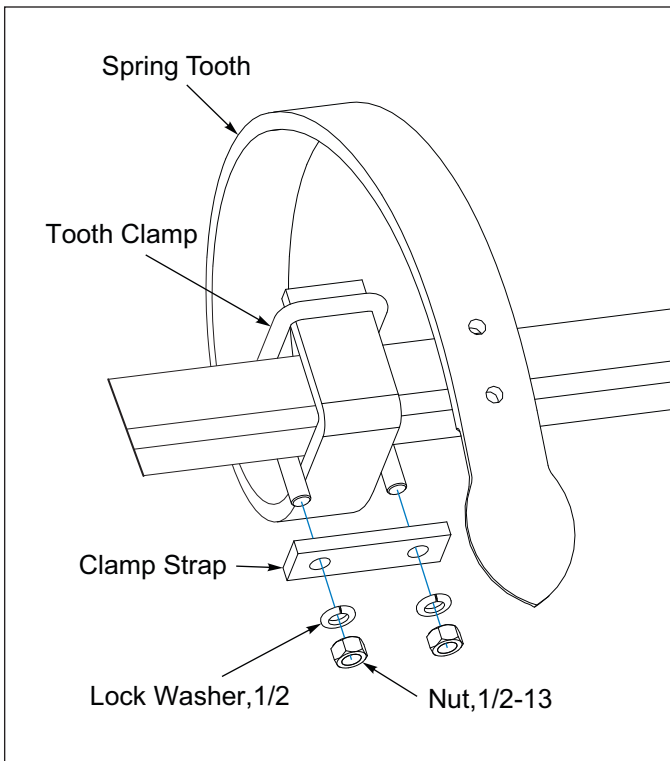

Figure 2-24: C-Tooth Installation

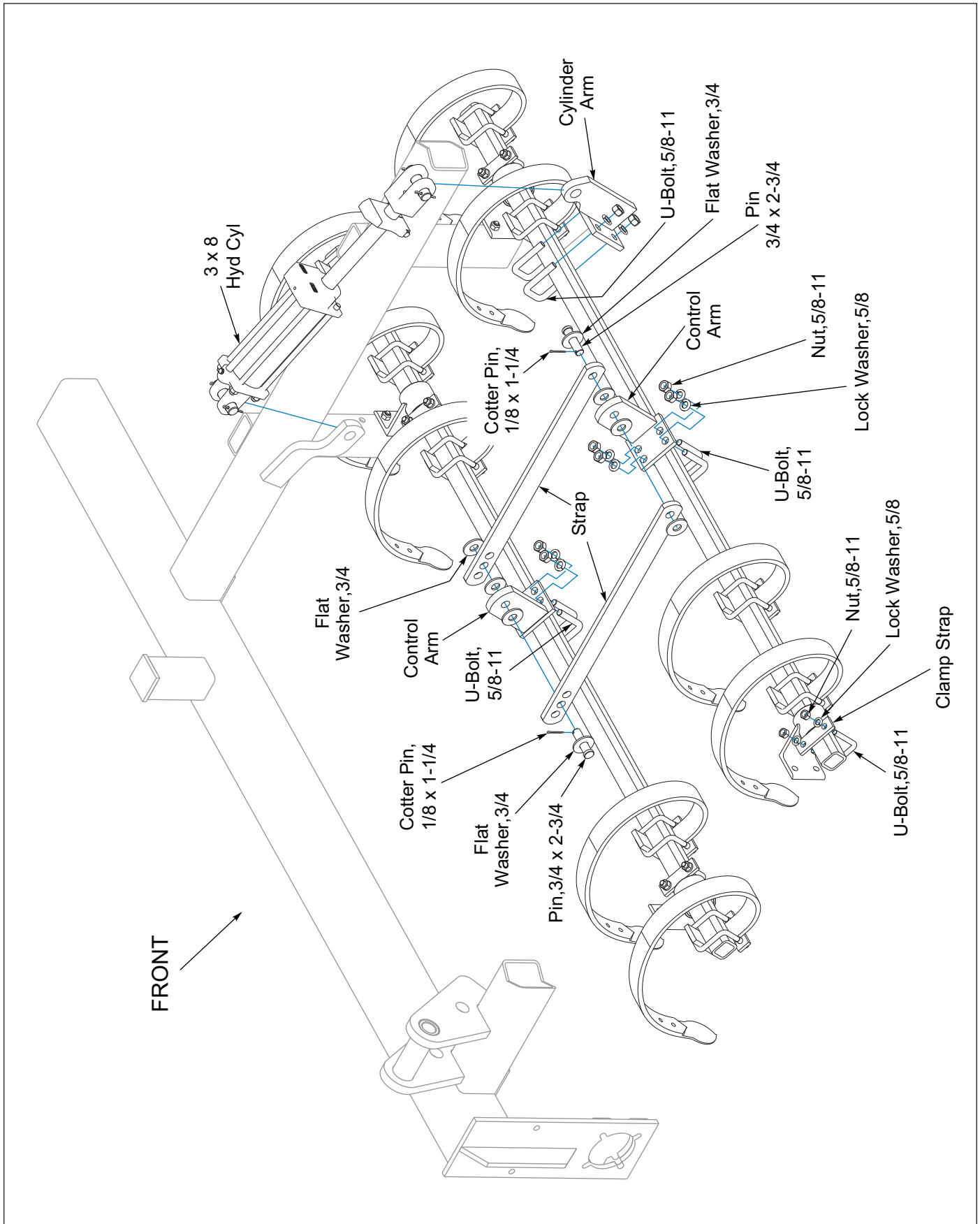

Figure 2-25: Wing Frame C-Tooth Installation

Hydraulic Installation

WARNING

Escaping fluid under pressure can be nearly invisible and have enough force to penetrate the skin causing serious injury. Use a piece of cardboard, rather than your hands, to search for suspected leaks. Wear protective gloves & safety glasses or goggles when working with hydraulic systems.

Refer to **Figure 2-23** through **2-33**.

The hydraulics consists of 3 separate circuits. Plumb the circuits in the following order:

1. **Wing Fold Circuit - Yellow.** The Wing Fold Circuit requires approximately 3 gallons of oil.
2. **Tooth Control - Blue and Purple.** The Tooth Control Circuit requires approximately 1-1/2 gallons of oil.
3. **Lift Circuit - Green.** The Lift Circuit requires approximately 2 gallons of oil.

Remove Fitting Caps prior to installing Fittings.

1. Route the hoses toward the center of the Frame to the Drawbar attaching the hoses to the Frame with Twin Hose Clamps where shown. **See Figure 2-26.** Continue routing the hoses down the center of the Drawbar through the Hose Loops and Hose Holder supports to the tractor.
2. Secure all hoses with tie wraps.

Tightening Procedure For JIC 37° Swivel Female Nuts

1. Check flare and seat for defects.
2. Lubricate the connection.
3. Install hoses without twists.
4. Hand tighten until connection bottoms.
5. Using 2 wrenches to prevent twisting, rotate the swivel nut 2 wrench flats (1/3 turn).
6. For reassembly, follow the same procedure but tighten only 1 wrench flat (1/6 turn).

Tightening Procedure For Swivel O-Ring Fittings

1. Lubricate O-ring and install the fitting until the metal washer which backs up the O-ring contacts the face of the boss.
2. Orient the fitting by turning counterclockwise up to 1 turn.
3. Tighten the lock nut using 50-60 foot pounds torque. **(See “Hydraulic Fitting Torque Specifications” on page 4-2.)**

Purging the Hydraulic Wing Fold, Transport and Tooth Control Cylinders

WARNING

Escaping hydraulic fluid can cause serious personnel injury. Relieve system pressure before repairing, adjusting, or disconnecting. Wear proper hand and eye protection when searching for leaks. Use cardboard instead of hands. Keep all components (cylinders, hoses, fittings, etc.) in good repair.

CAUTION

Restrictors are installed in the rod end of wing fold cylinders to prevent uncontrolled dropping of wings. Removal of the restrictors, or improper installation can result in serious damage to implement.

The hydraulic system is not filled with oil and should be purged of air before transporting and field operations. Carefully hitch the Pulvi-Mulcher to the tractor and connect the hydraulic wing fold hoses. Check to make sure the tractor hydraulic reservoir is full of the manufacturer's recommended oil.

1. Unpin the end(s) of the wing fold cylinders, and position them so the rod end can extend and retract without contacting any frames or other parts. Connect the cylinder hoses to the tractor and fully extend and retract the cylinders 5 or 6 times. The cylinder rod travel should be smooth and positive when all air has been purged from the system. Due to large amounts of hydraulic oil required, recheck the tractor fluid level to make sure it is within proper operating limits.
2. If the cylinders are not working evenly or together, fully extend the cylinders and continue to hold the lever to purge any remaining air. Do not loosen any hoses or fittings.
3. Recheck tractor reservoir to make sure it is within operating limits.
4. The hydraulic wing fold system is equipped with restrictors in the cylinders to prevent uncontrolled falling of wing frames when unfolding. Removal or improper assembly of these restrictors can cause the machine to fold improperly and result in serious machine damage

Repeat the procedure for the Transport and Tooth Control Circuit.

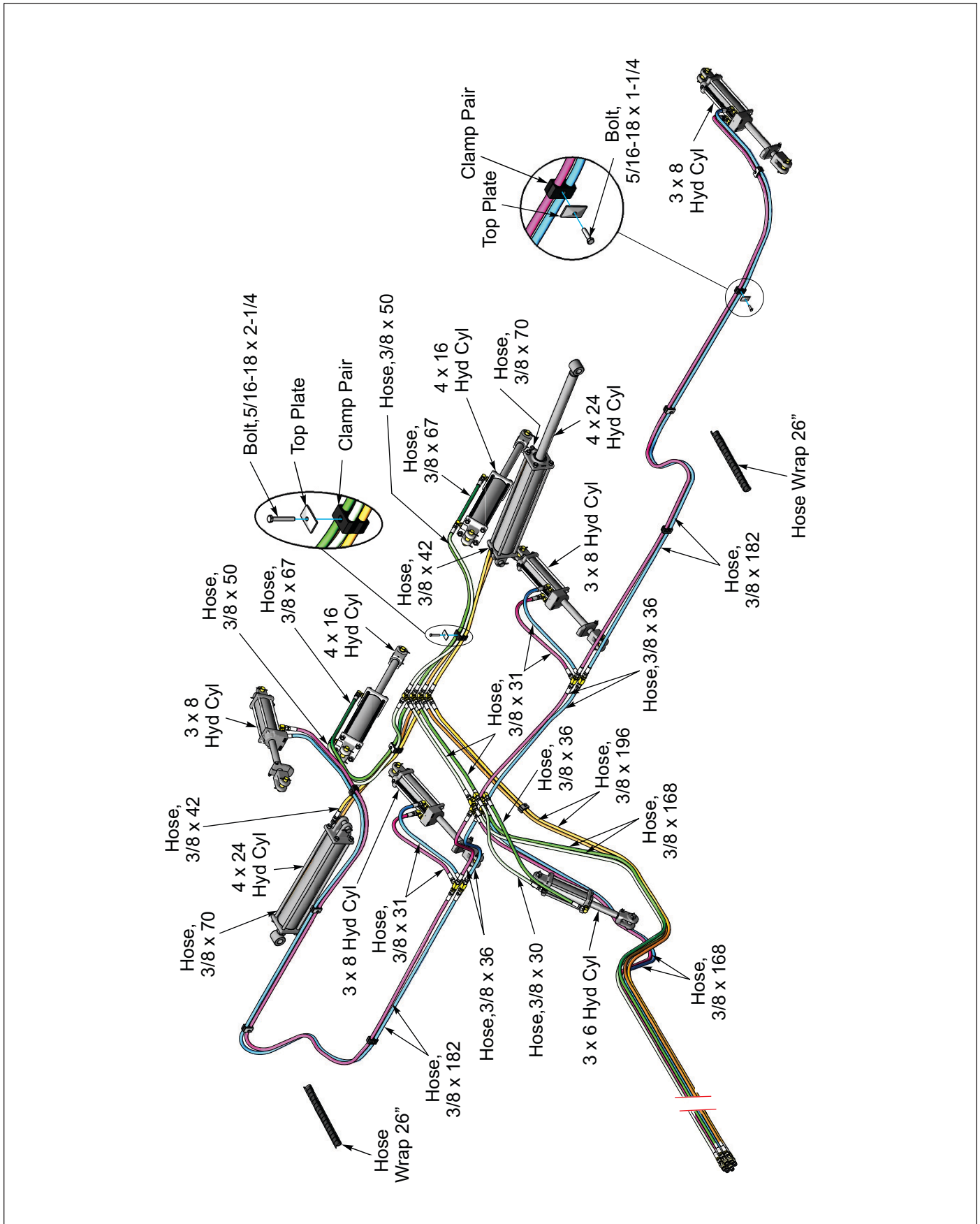

Figure 2-26: Hydraulic Layout (1 of 5)

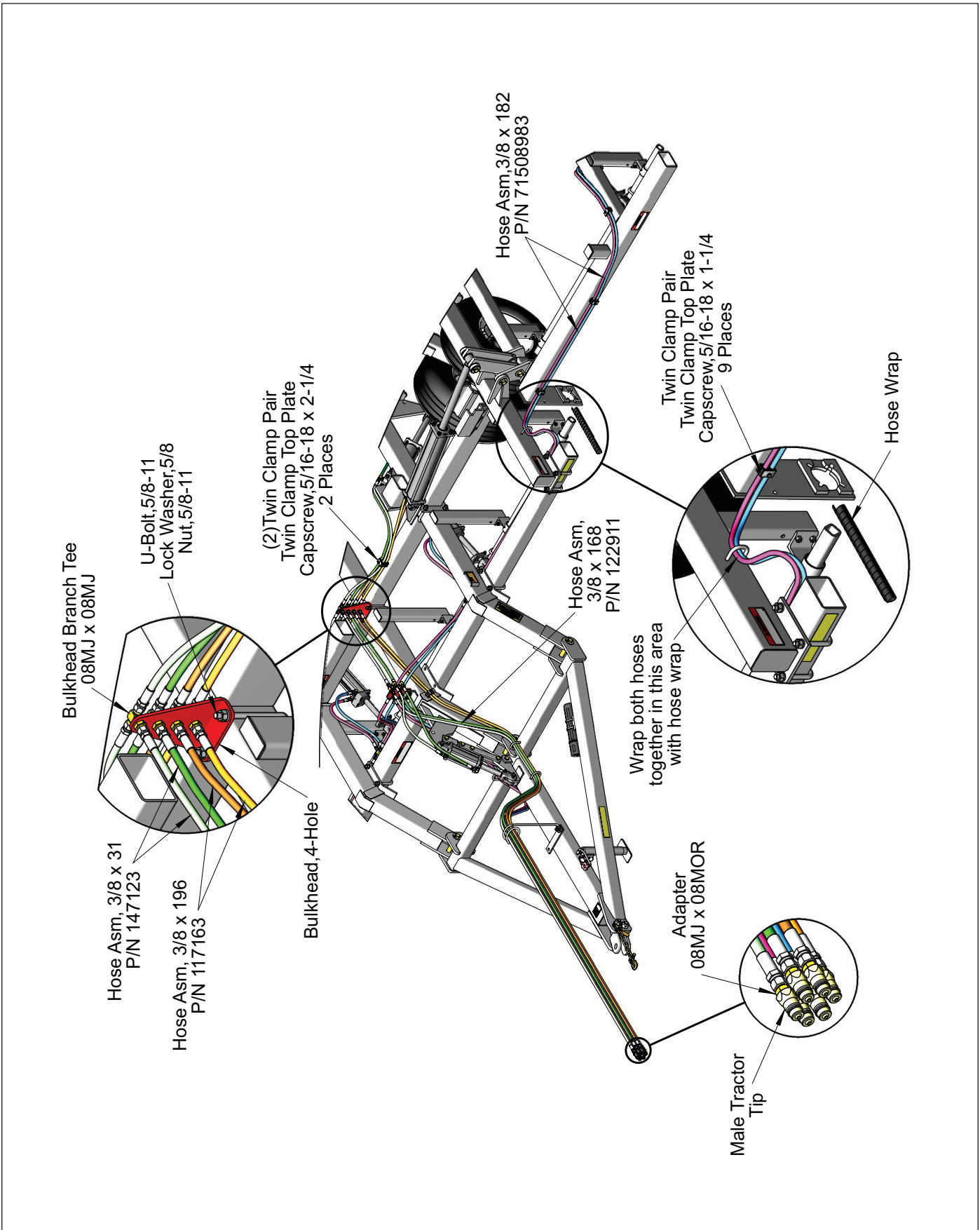

Figure 2-27: Hydraulic Layout (2 of 5)

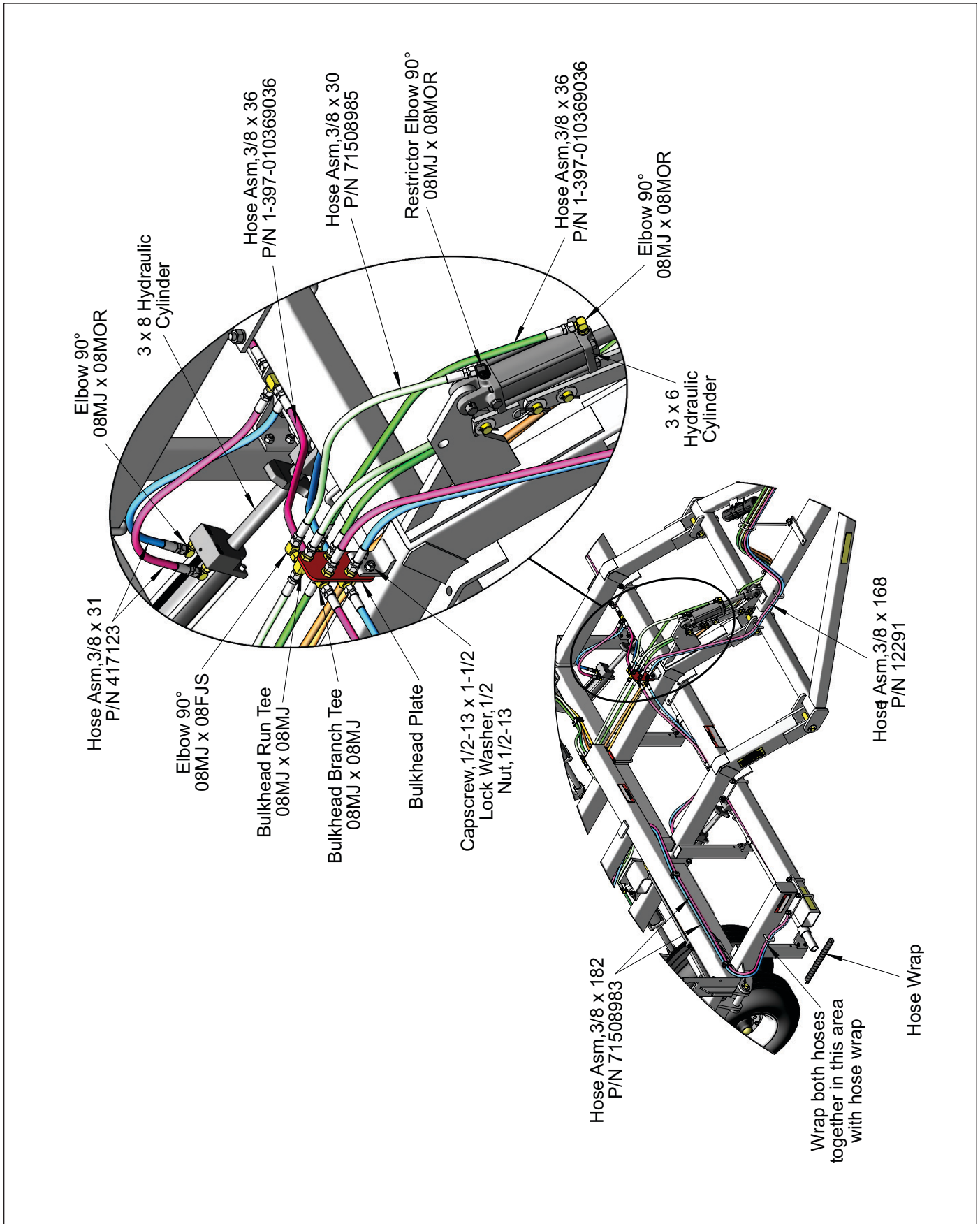

Figure 2-28: Hydraulic Layout (3 of 5)

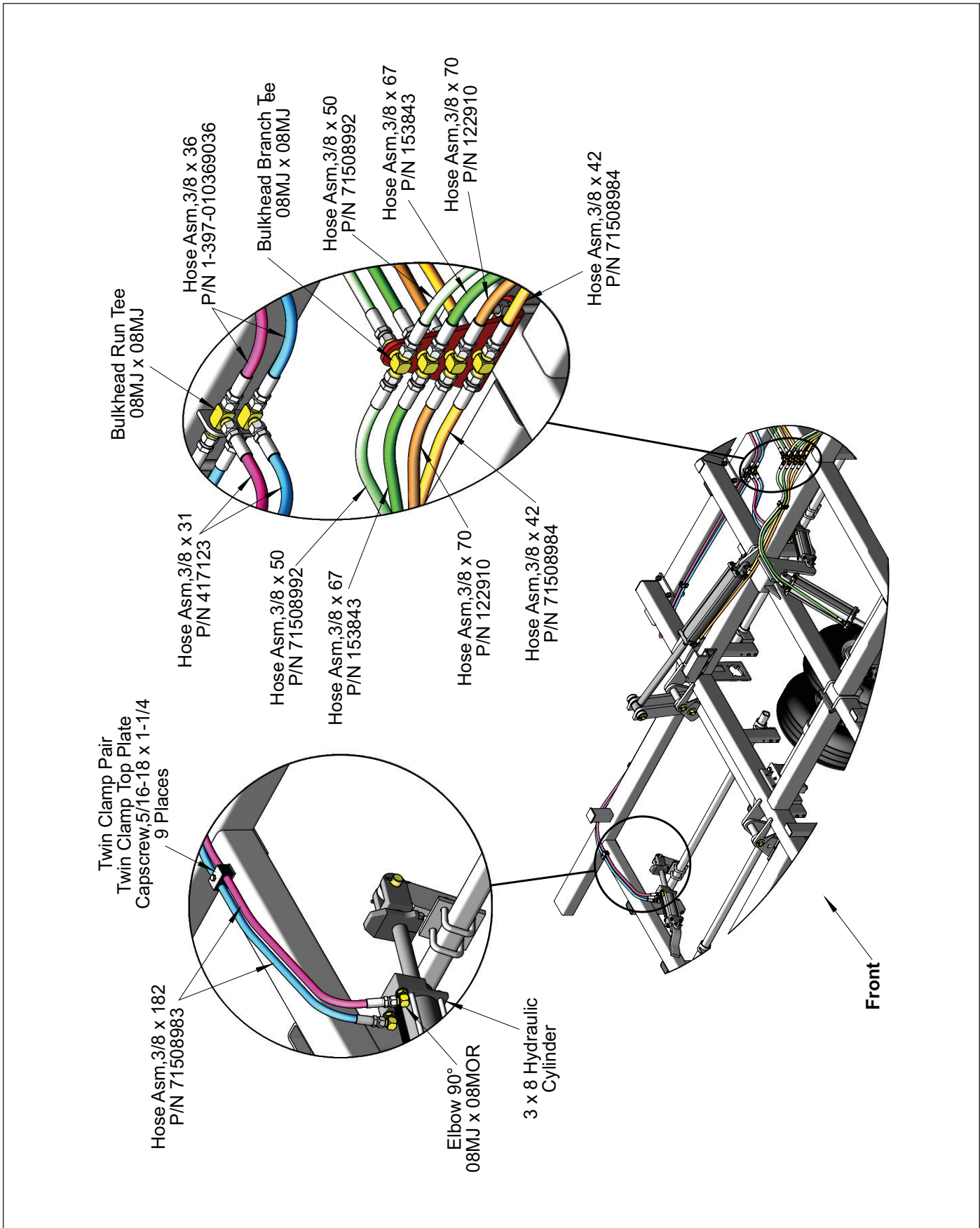

Figure 2-29: Hydraulic Layout (4 of 5)

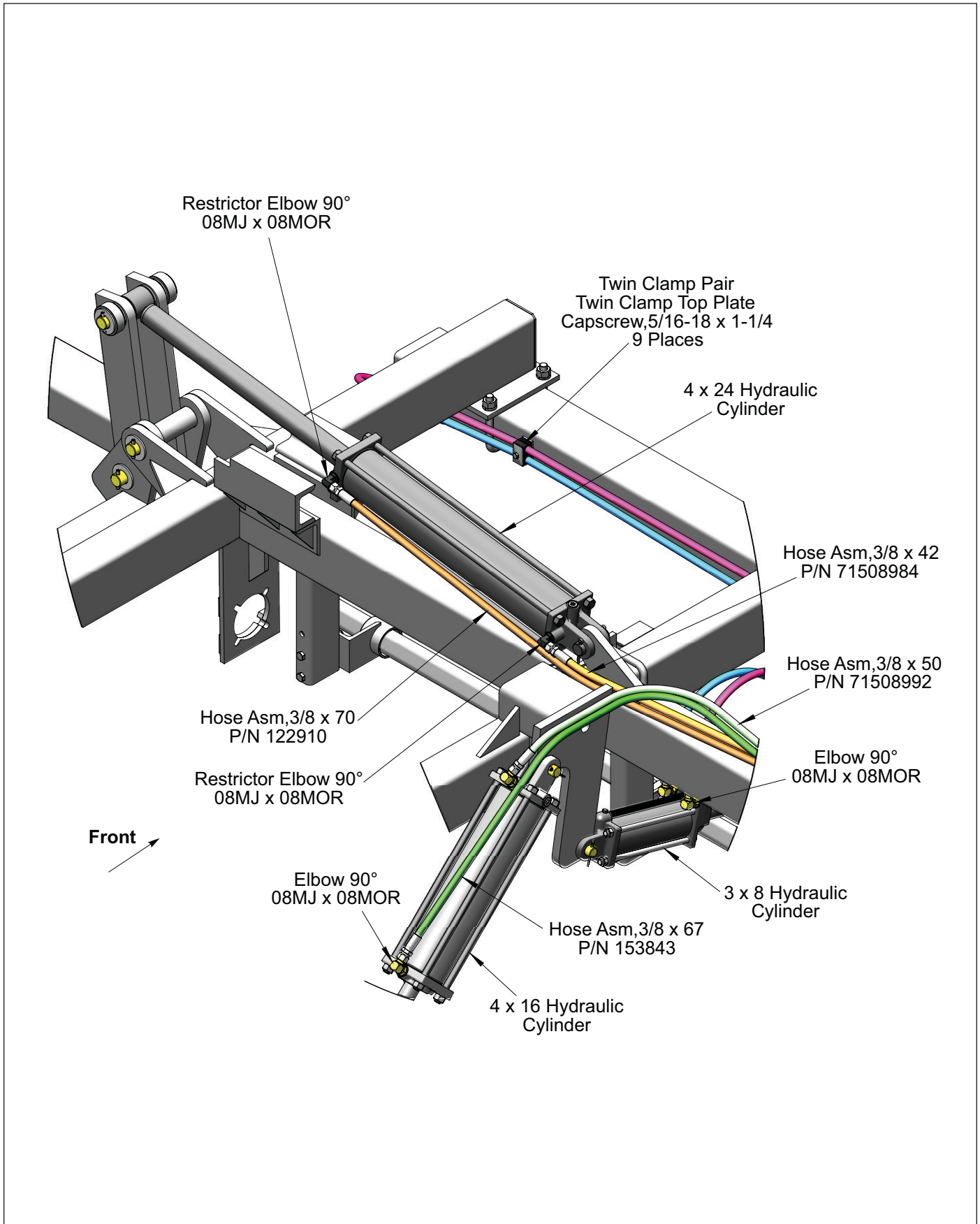

Figure 2-30: Hydraulic Layout (5 of 5)

Hydraulic Fold Circuit

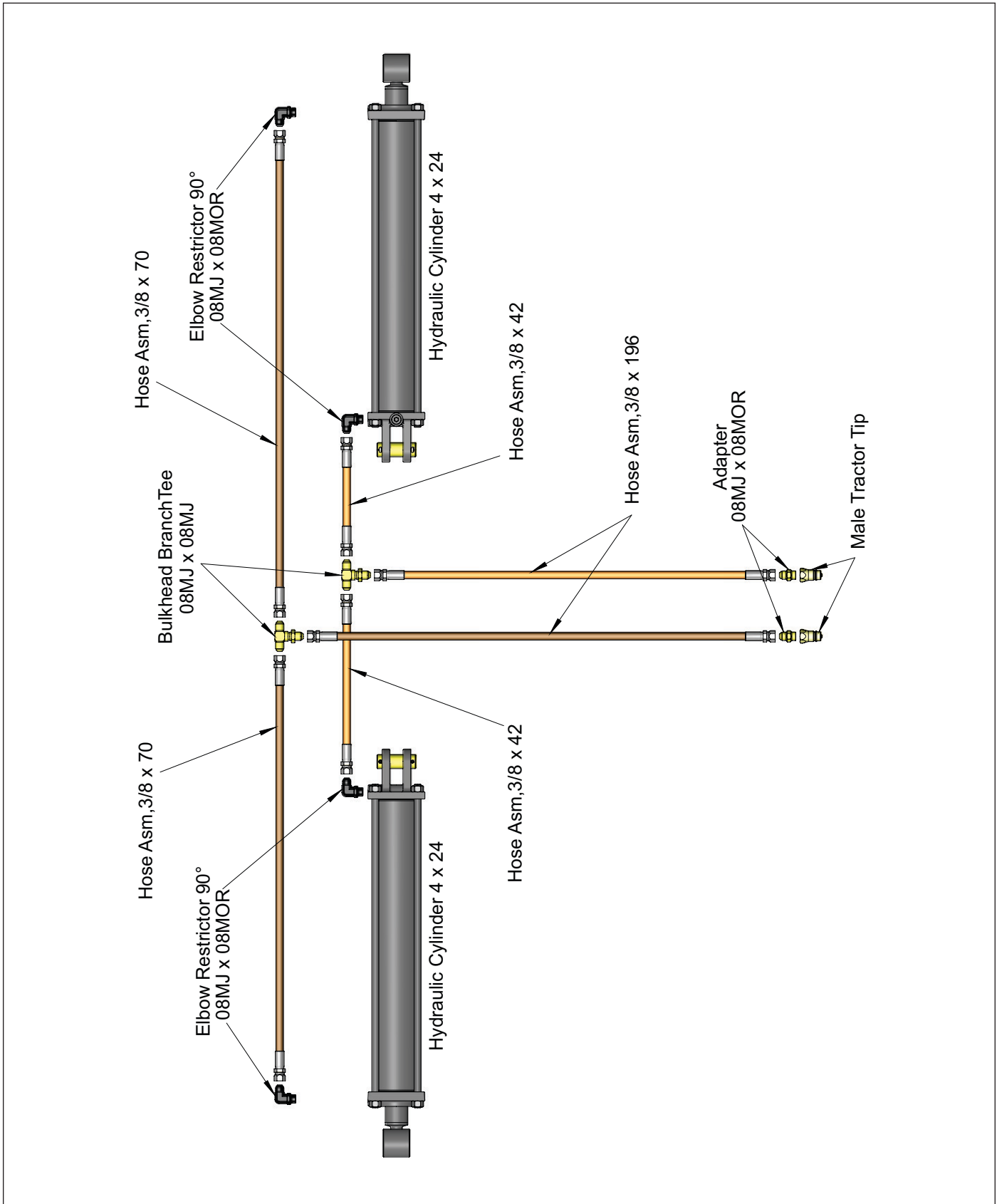

Figure 2-31: Hydraulic Fold Circuit

Hydraulic Tooth Control Circuit

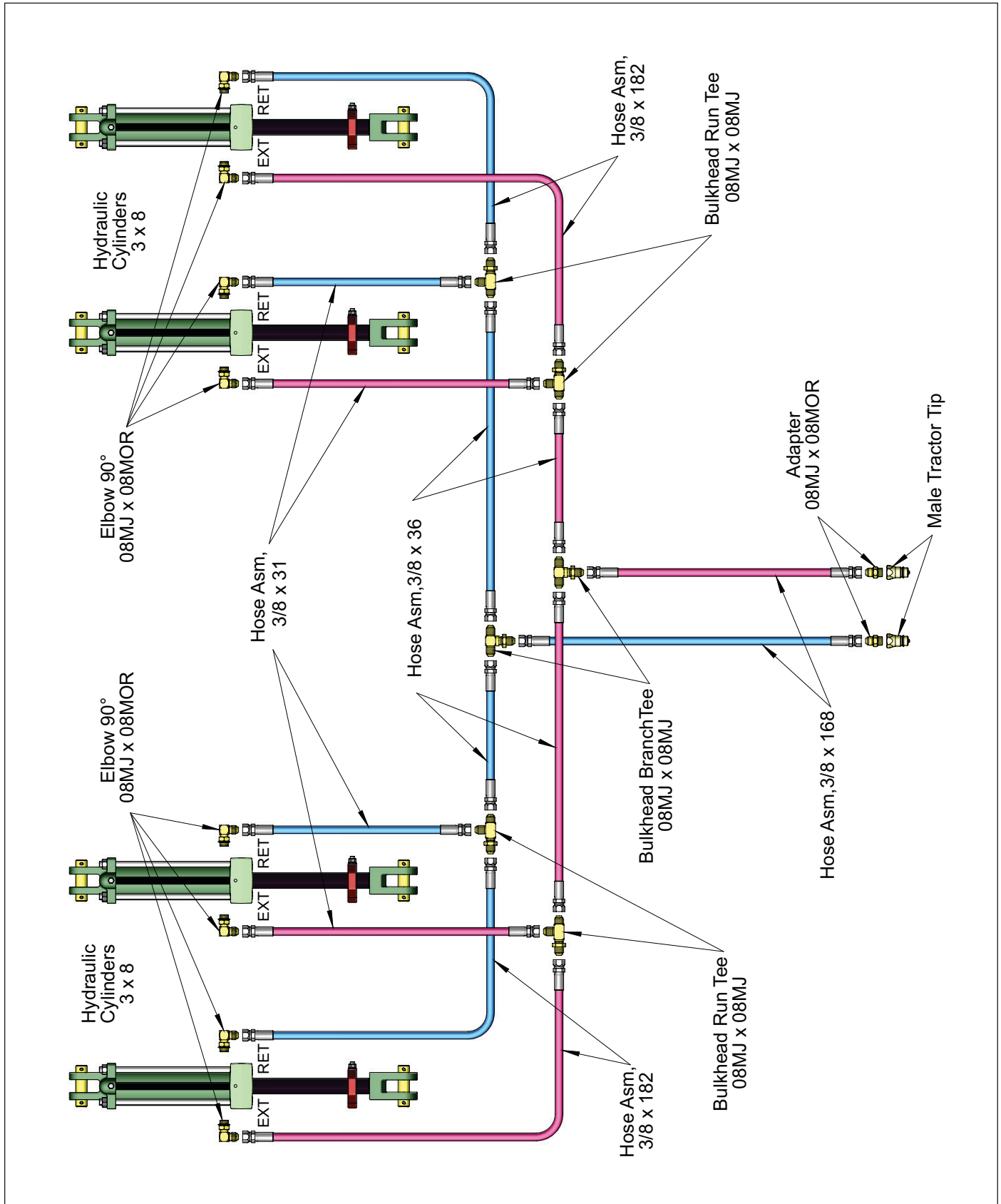

Figure 2-32: Hydraulic Tooth Control Circuit

Hydraulic Lift Circuit

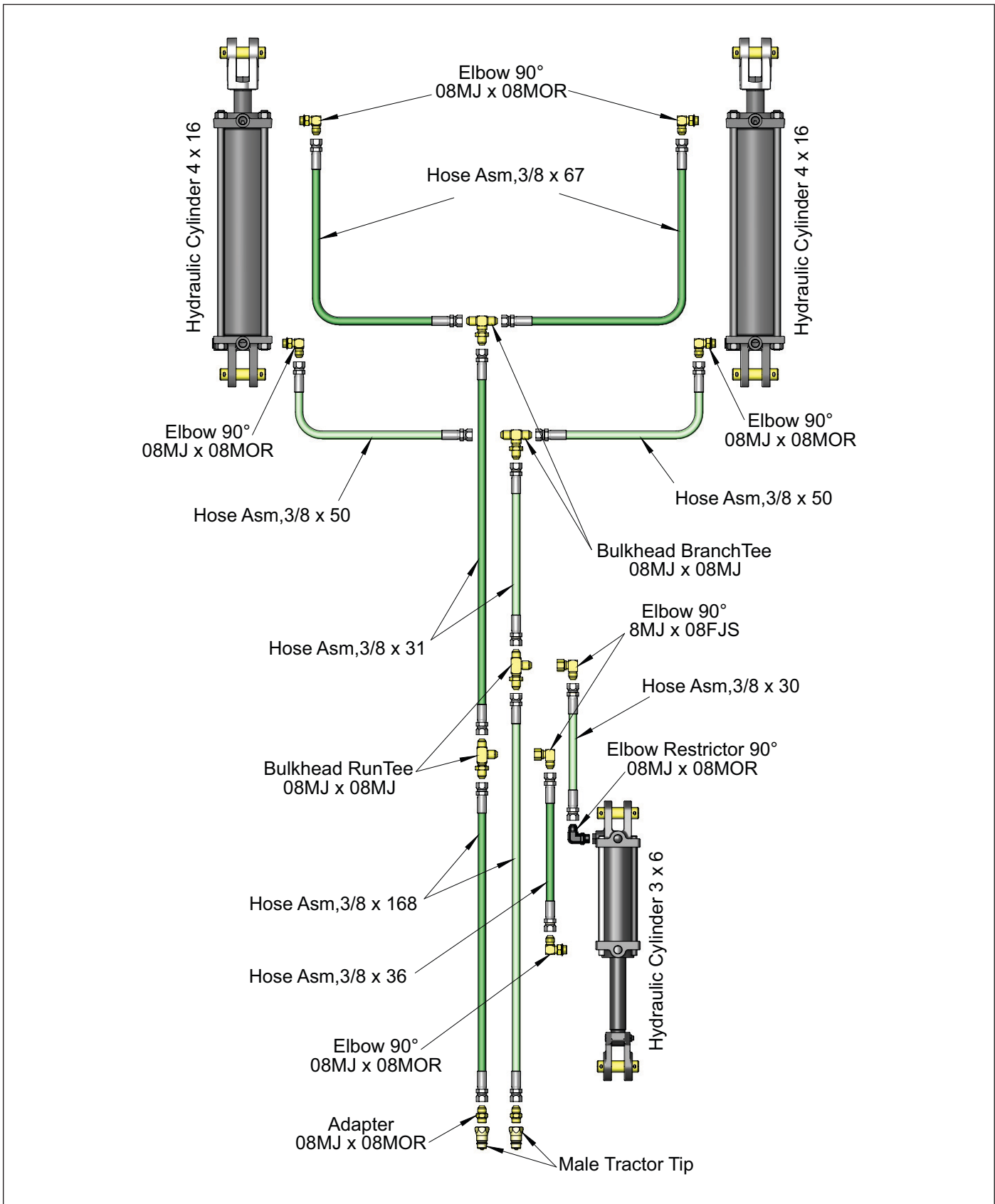

Figure 2-33: Hydraulic Lift Circuit

Center Roller Installation

The longer roller is installed on the Left Rear.
 Insert the front and rear roller assembly ends, without the Clamp Ring into Center Bracket Bearings.

NOTE

Be sure clamp rings are towards the outside, so assembly can be adjusted when needed.

Install End Bracket with the bearing to the inside on the Front Frame Tube, and the End Bracket Assembly with the bearing on the outside on the Rear Frame Tube using 3/4-10 U-bolts, Lock Washers and Nuts.

NOTE

Crowfoot wheels have arrows on the spokes showing direction of rotation. Arrows must follow direction of travel.

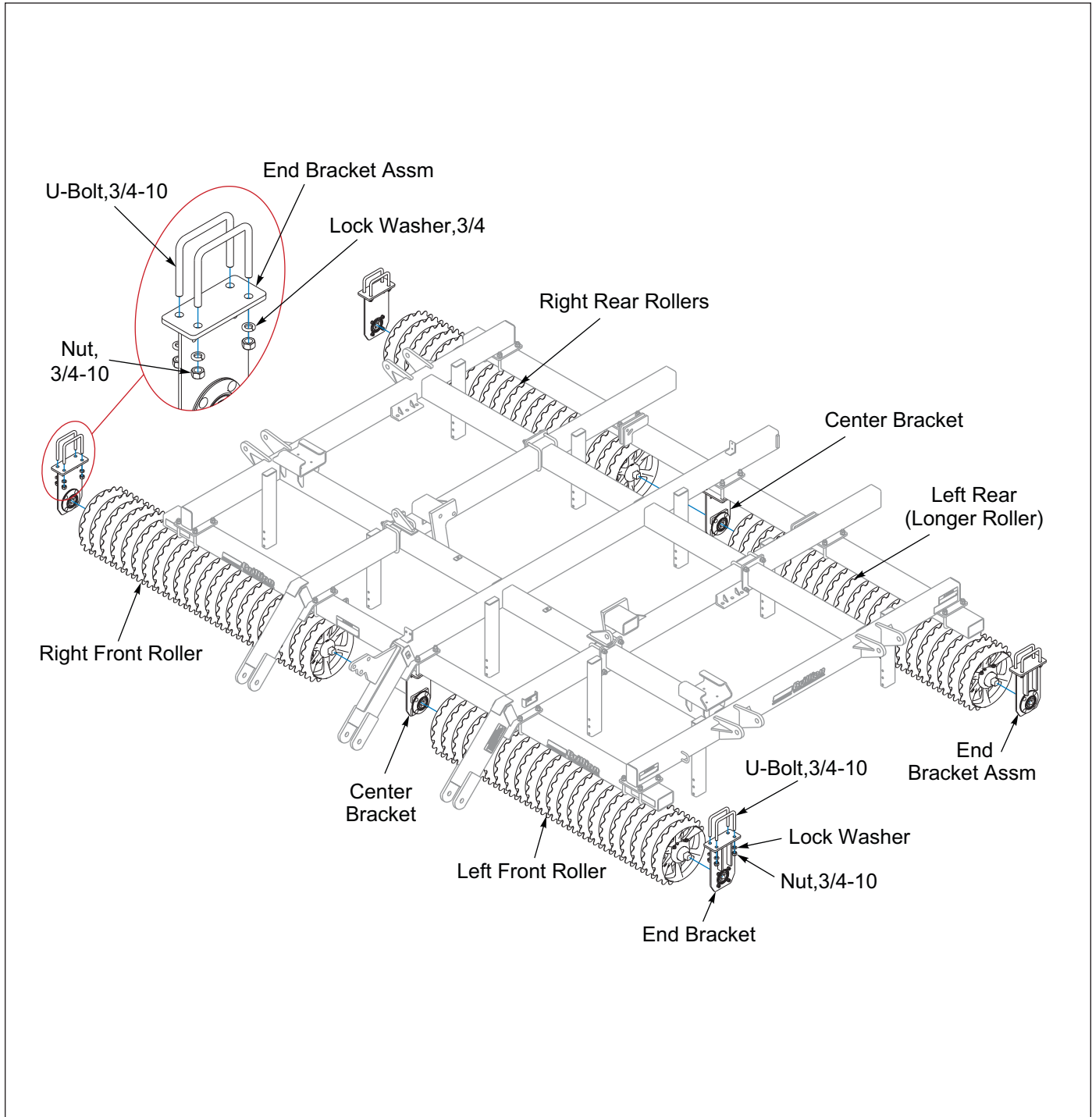

Figure 2-34: Center Roller Installation

Wing Roller Installation

Position the Bearing between two bearing flanges and assemble it to the inside of the Wing Frame Bearing Plate using 1/2-13 x 1-1/2 Carriage Bolts, Lock Washers and Nuts. Insert the front and rear roller assembly ends, without the Clamp Ring into End Plate Bearings.

NOTE

Be sure clamp rings are towards the outside, so assembly can be adjusted when needed.

Install End Bracket with the bearing to the outside on the Front and Rear Frame using 3/4-10 U-bolts, Lock Washers and Nuts.

NOTE

Crowfoot wheels have arrows on the spokes showing direction of rotation. Arrows must follow direction of travel.

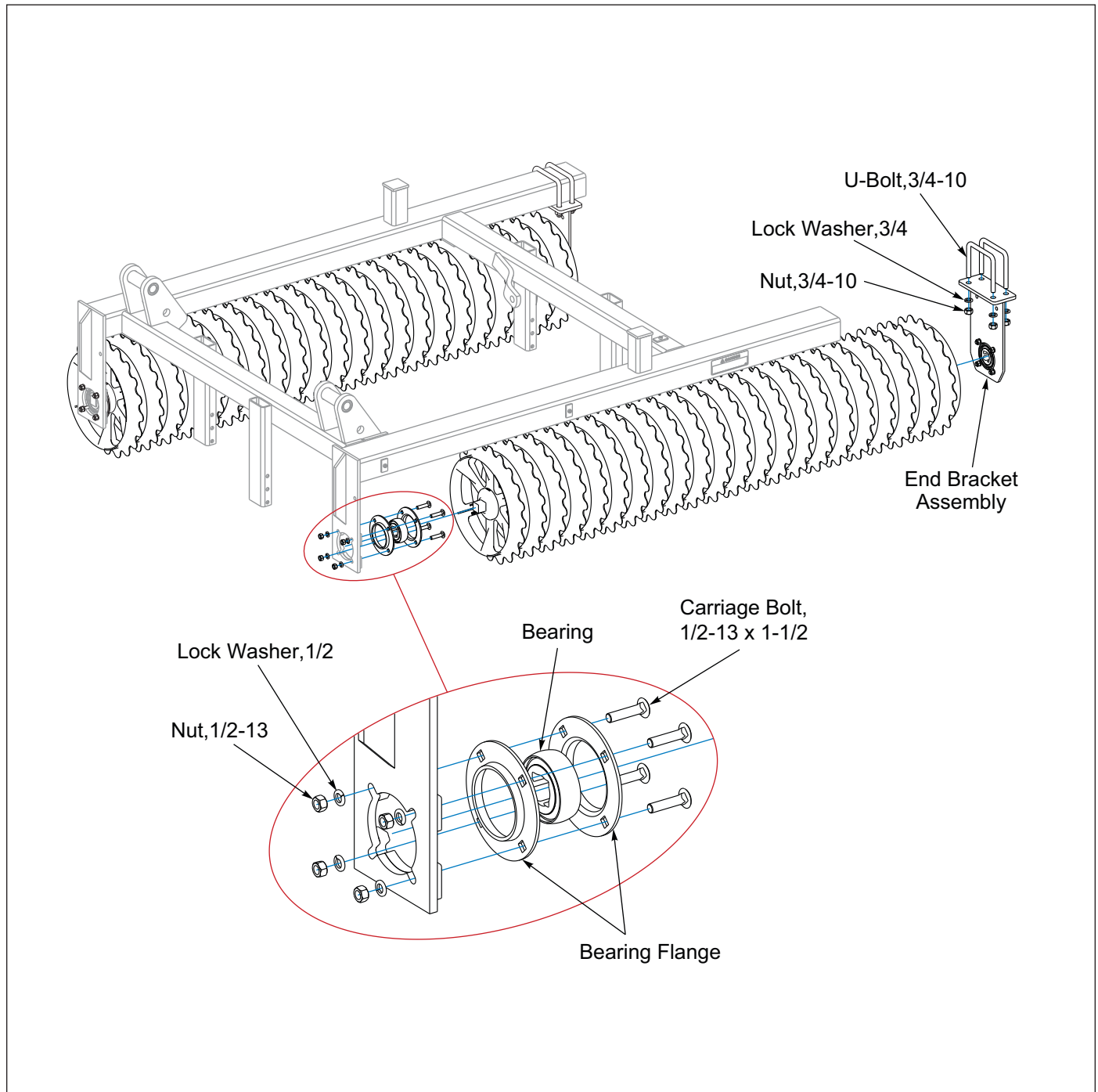

Figure 2-35: Wing Roller Installation

Rear Scraper Assembly

For Notched Ductile Wheels Only.

Scraper brackets are mounted on the inside of the end brackets and center bracket and attach with 1/2-13 x 1-3/4 Bolts, Flat Washers, Lock Washers, and Nuts. The scraper tubes are to be centered with respect to the rollers.

1. With the Scraper Tube between 2 inch wide Scraper and Bracket, mount Scraper to the Bracket with 3/8-16 x 3-1/2 Bolts, Flat Washers, Lock Washers, and Nuts. These scrapers are fixed and cannot be

moved side to side. Take the other 2" wide scraper and mount it on the tube by the right hand roller end wheel and the center bearing bracket using 3/8-16 U-Bolts, Flat Washers, Lock Washers, and Nuts. **See Figure 2-36.**

2. Attach the 2-1/2 inch Scrapers to the tube using 3/8-16 U-Bolts, Flat Washers, Lock Washers, and Nuts.
3. Gap between the wheel and the scraper should be 1/4 inch. **See Figure 3-5.**

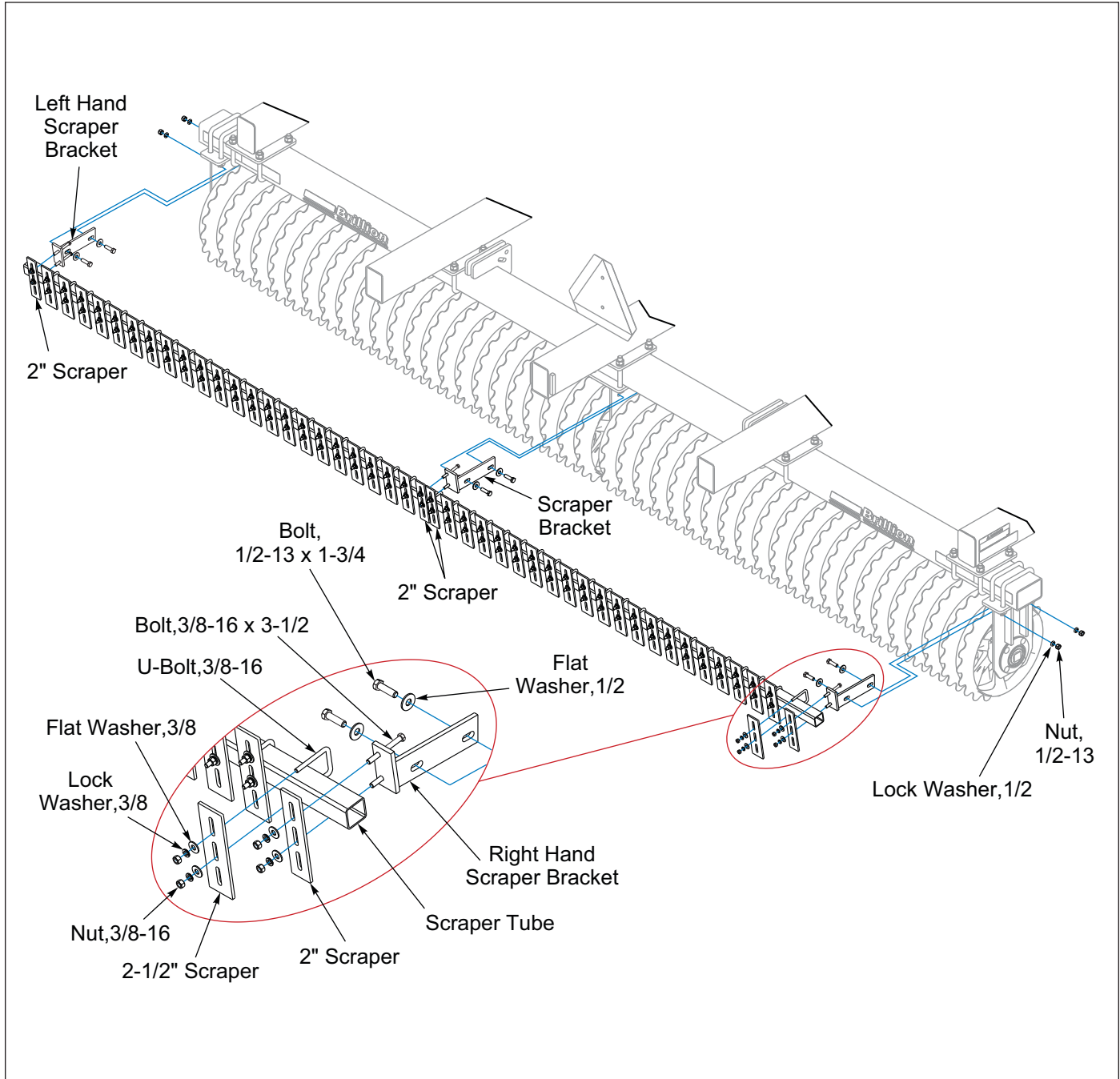

Figure 2-36: Center Rear Scrapers

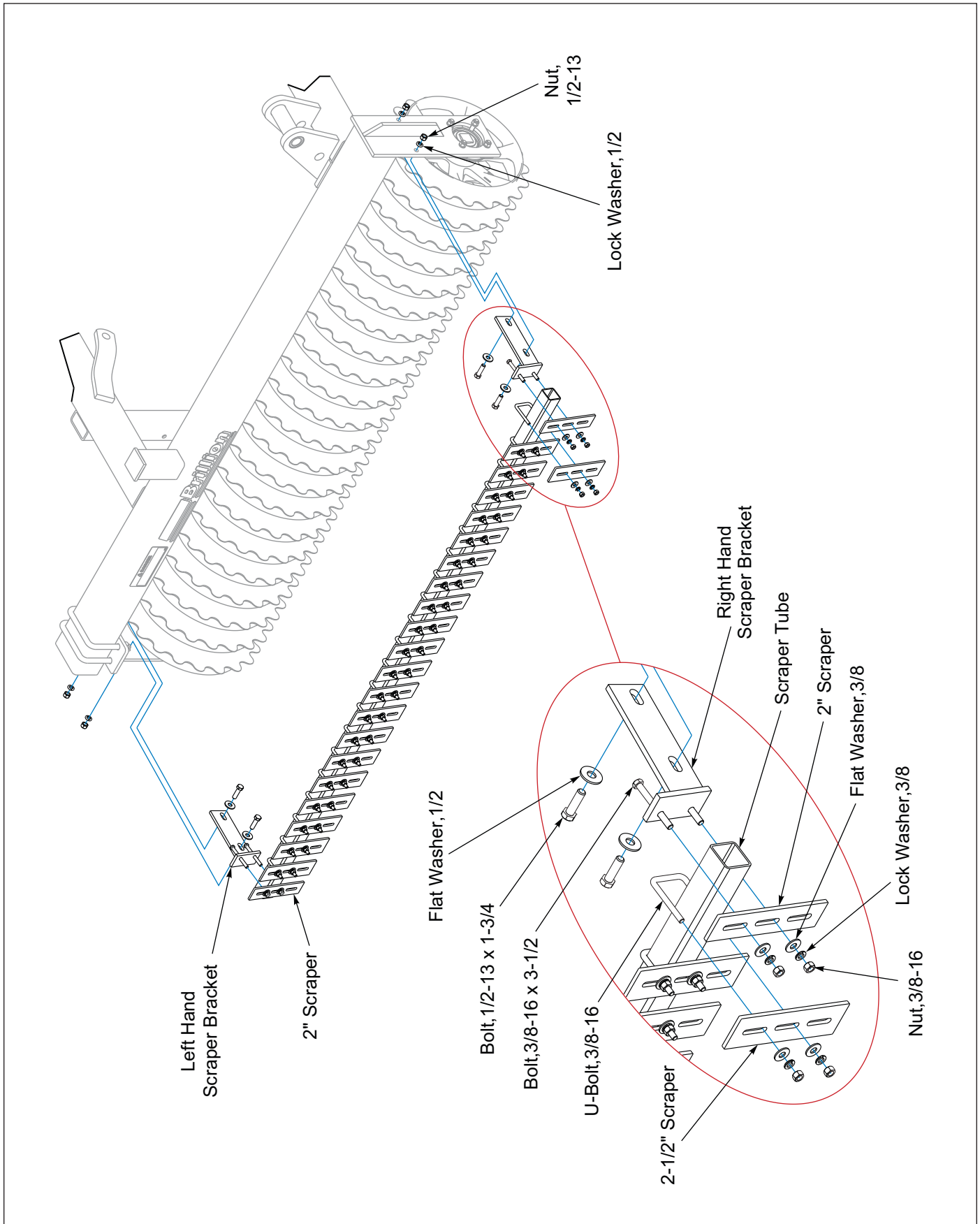

Figure 2-37: Wing Rear Scrapers

LED Lamp and Harness Installation

NOTE

Unless otherwise noted the following installation instructions apply to all WL Models.

1. Install a Lamp Bracket approximately 46" from center line on each side of the rear frame tube using 1/2-13 U-Bolts and Flanged Locknuts. **See Figure 2-40.**
2. With the Red LED Lamp facing rearward, attach the Lamp to the outside and the Decal Bracket to the inside of the Lamp Bracket using 1/4-20 x 1-1/2 Screws and Locknuts. **See Figure 2-41.**
3. Install a Lamp Bracket flush with the rear frame tube end using 1/2-13 U-Bolts and Flanged Locknuts. **See Figure 2-40.**
4. Place the Amber LED inside the Light Shield. Attach Lamp and Shield to the outside and the Decal Bracket to the inside of the Lamp Bracket with 1/4-20 x 1-3/4 Screws and Locknuts. **See Figure 2-41.**
5. Attach the Light Module to the Light Module Bracket using two 1/4-20 X 1-1/2 Screws and Locknuts. **See Figure 2-39.**
6. Attach the Light Module Bracket to the rear of the left Inner Frame Tube just in front of the Rear Frame Tube using 3/8-16 U-Bolts and Locknuts.

IMPORTANT

Connectors marked with Yellow Tape is Left Side and Green Tape is Right Side.

7. Layout the LED Lamp Harness along the Rear Frame Tube with the 3-Way and the 2-Way connector cords marked with yellow tape on the left side and the 3-Way and the 2-Way connector cords marked with green tape on the right side of the machine. Plug the 3-Way connectors into the Red Lamps and the 2-Way connectors into Amber Lamps. Route the Harness up the Left Inner Frame Tube to the Light Module 6-Way connector and connect.
8. Connect the 7-Pin Harness 4-Way connector into the Light Module. Run the Harness along the Left Inner Frame Tube with the Hydraulic Hoses, down the Drawbar Loops and through the Hose Holder to the Hitch Point.
9. Bundle and secure any excess cord with tie straps.
10. Apply the reflector decals to Decal Plate Mounts. The amber reflector decals should be front facing on the outer Decal Plate Mounts. The red reflector decals and orange decals should be rear facing on both the inner and outer decal plate mounts. **See Figure 2-41.**

IMPORTANT

All wires must be firmly attached to machine frame members, or hydraulic lines, so they don't sag or become torn loose by field debris. Use the cable and hose ties provided.

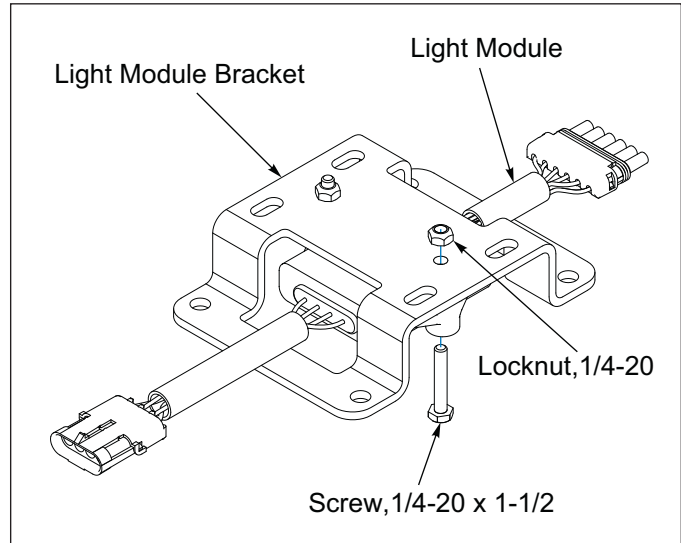

Figure 2-38: LED Module and Bracket

11. Attach the SMV Sign to the bracket weldment located on the rear of the Center Frame Tube using two 5/16-18 x 1 Screws, Flat Washer and Nuts.

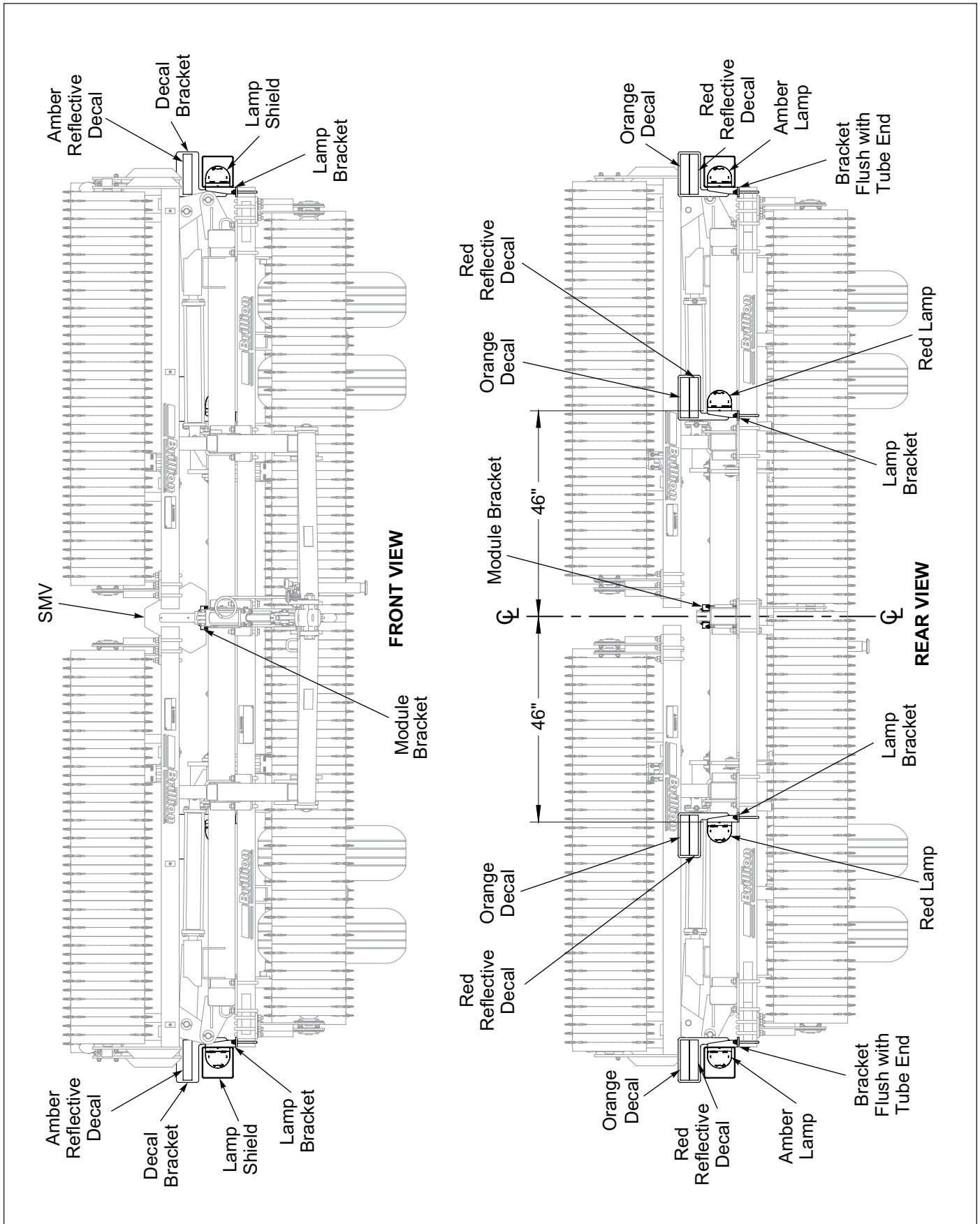

Figure 2-39: LED Warning Lights Installation Dimensions

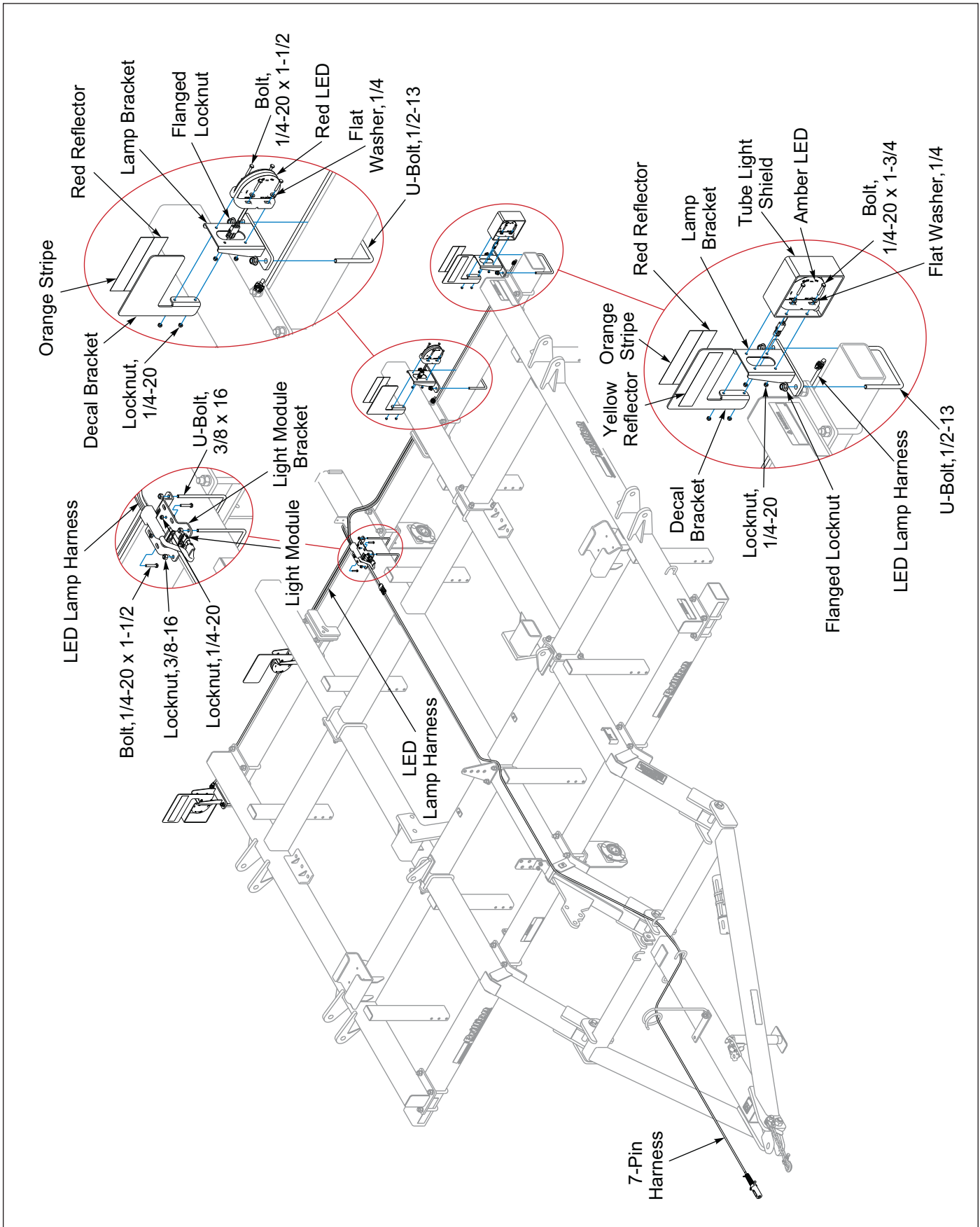

Figure 2-40: LED Lamp Installation

Front Scraper Installation - Optional

Installation similar to Rear Scraper, except the wing uses two short Scrapers on the hinge end for clearance. See Page 2-39.

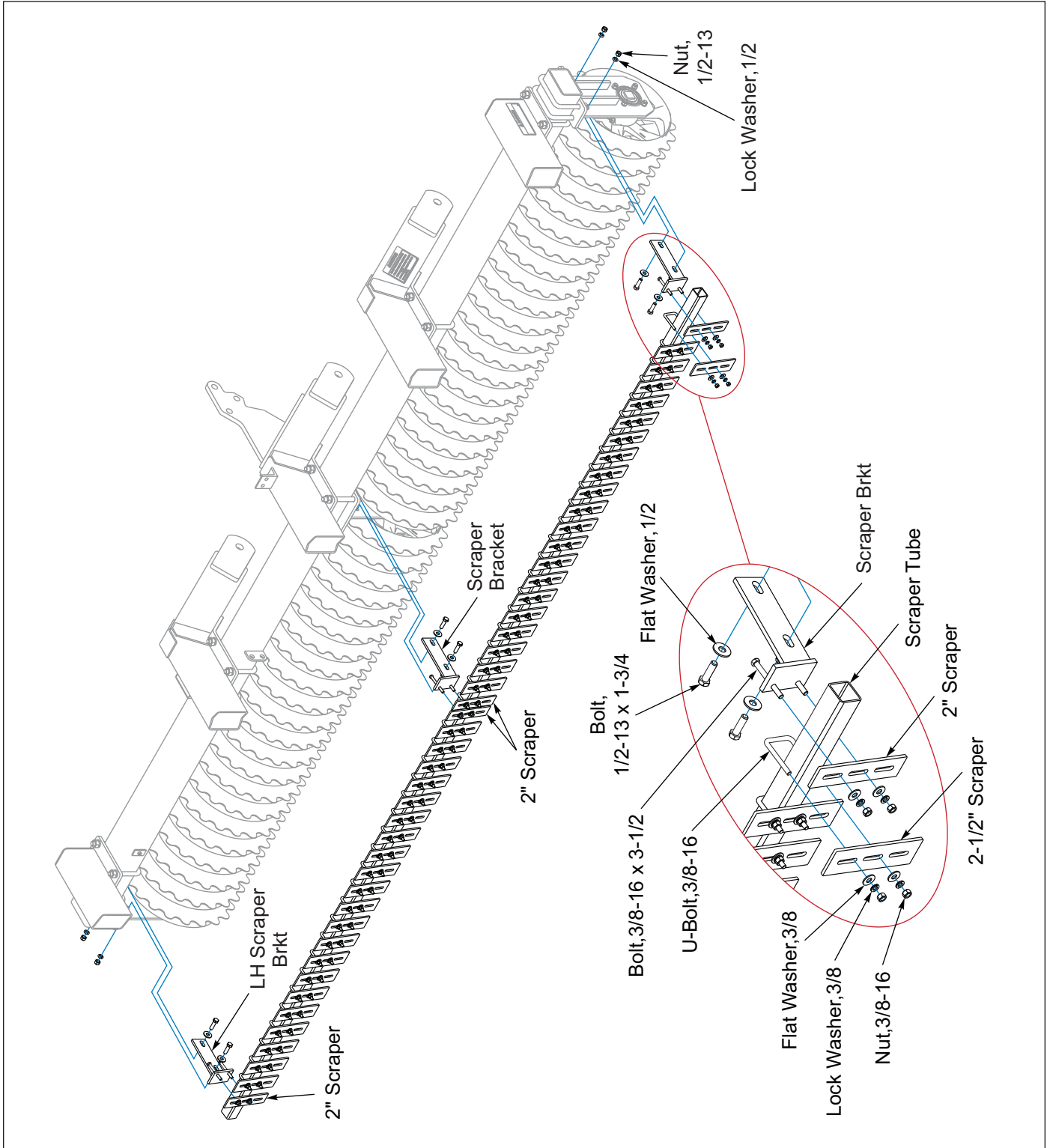

Figure 2-41: Center Front Scraper - Optional

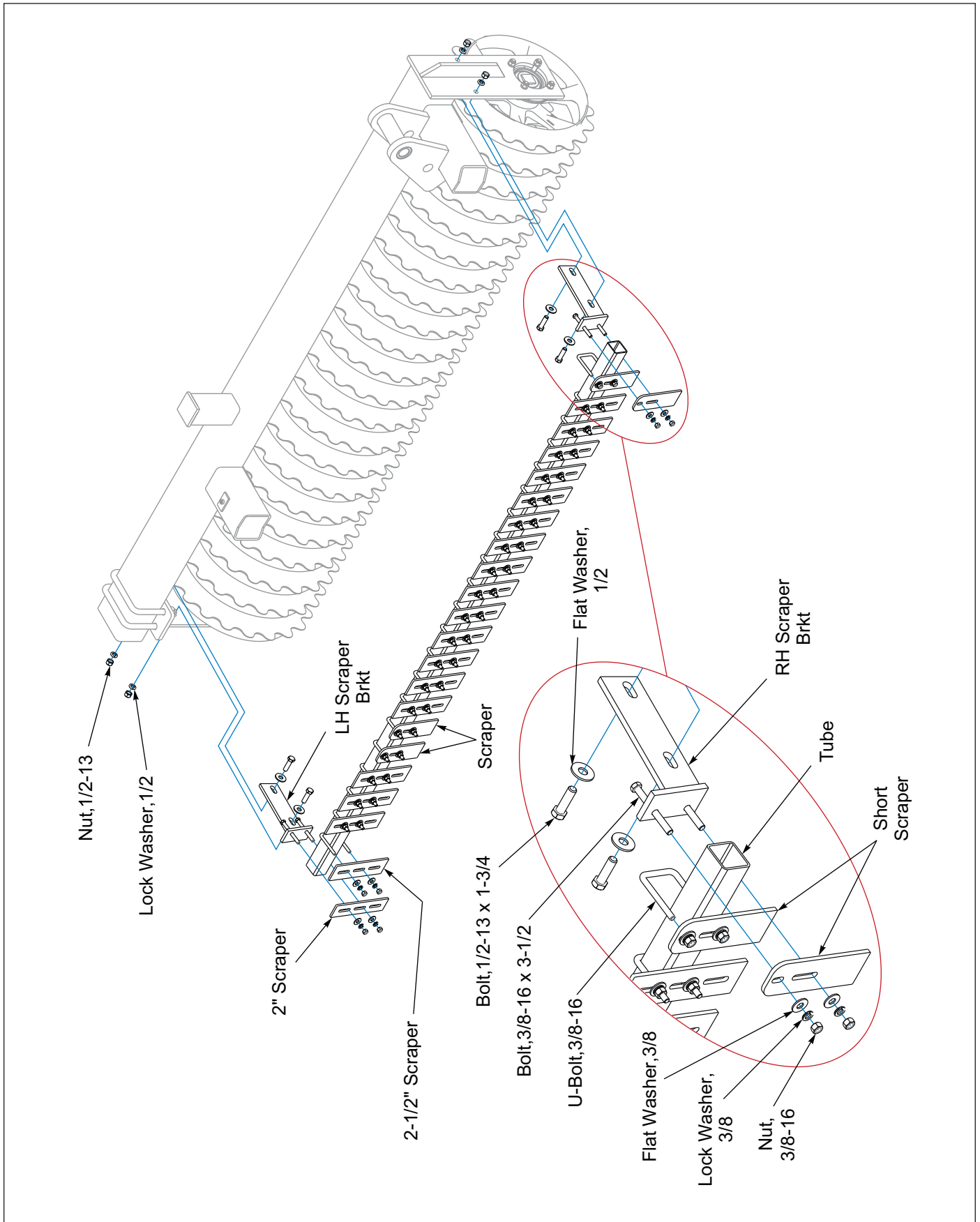

Figure 2-42: Wing Front Scraper - Optional

Land Leveler Installation - Optional

Refer to **Figure 2-44** for Land Leveler mounting dimensions.

1. Attach the Left and Right Hand Brackets to the Front Center Frame Tube and Wing Frame Tube using 1/2-13 U-Bolts, Lock Washers and Nuts. When the bracket is in position, left and right hand is determined by which side of the bracket the arm projects from. See **Figure 2-45**.

2. Attach the Left and Right Hand Adjustment Angles to the Brackets with 1/2-13 x 1-1/2 Bolts, Lock Washers and Nuts. The hoses mounted on the front of the wing tube may need to be moved and tied down with a cable tie to allow proper mounting of brackets. Do not tighten at this time.
3. Attach the Center and Wing Levelers onto the Adjustment Angles to the highest position that does the required job. Secure with 1/2-13 x 1-1/2 Bolts, Lock Washers and Nuts. Tighten all fasteners.

NOTE

If the soil pushes ahead of the bar it is set too low.

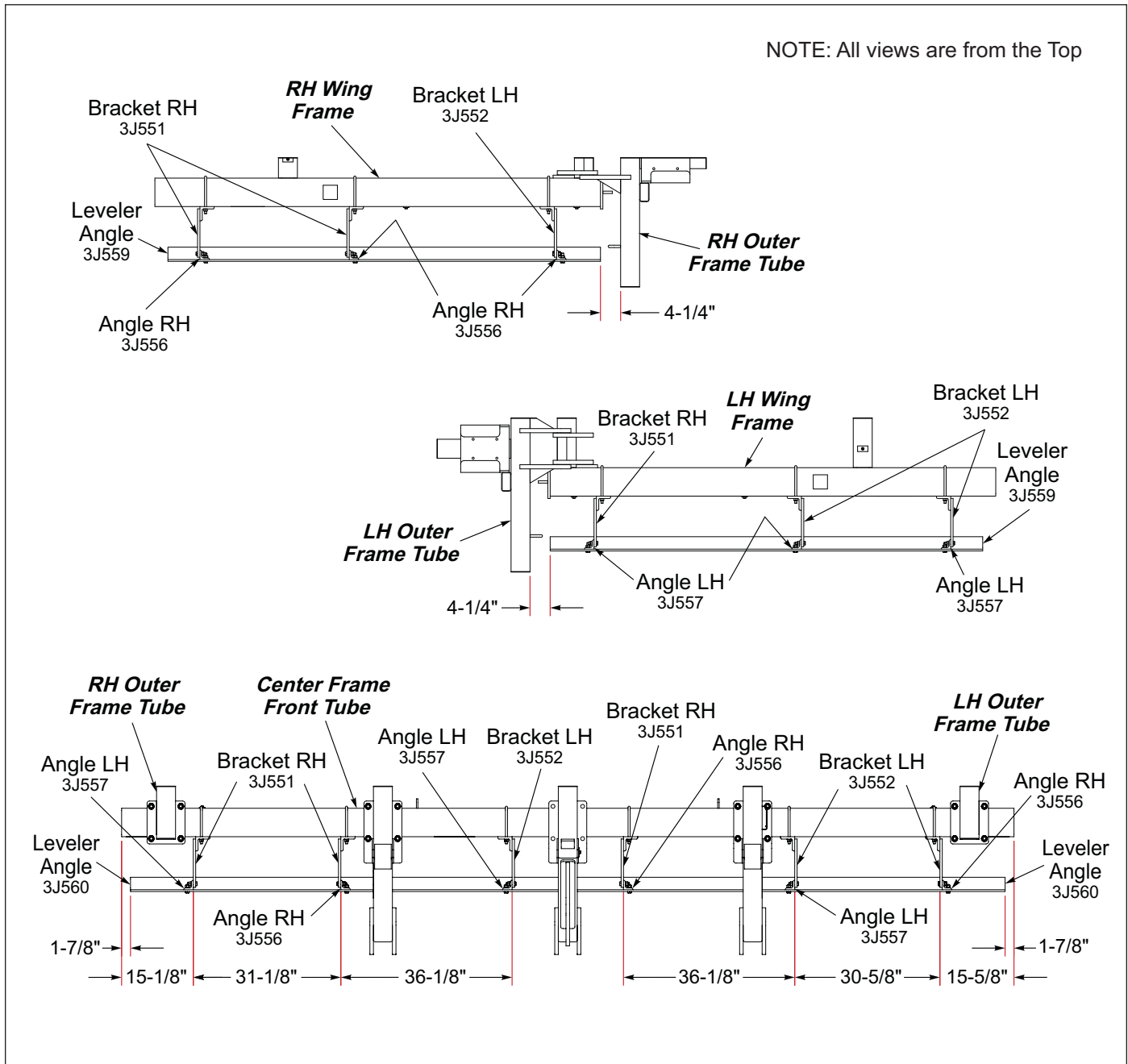

Figure 2-43: Land Leveler Mounting Dimensions - Optional

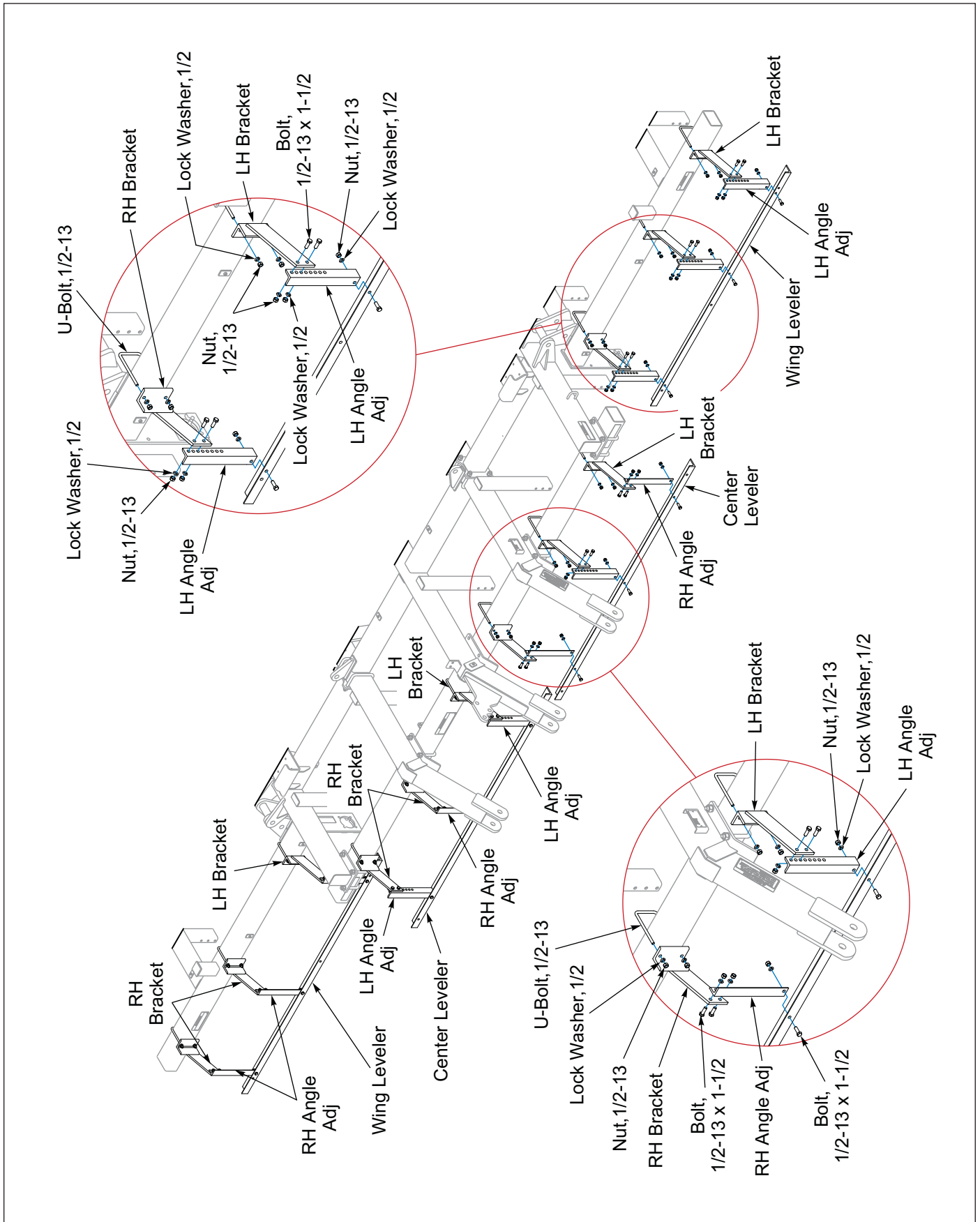

Figure 2-44: Land Leveler - Optional

V-Leveler Installation - Optional

Refer to **Figure 2-45** for V-Leveler mounting dimensions.

1. Place the V-Leveler Bracket on top of the center drawbar tube. Secure with 3/4-10 U-Bolts and Locknuts. Do not tighten at this time. Attach the V-Leveler to the Bracket by sliding 1 x 12-1/2 Pin through and securing with 1" Flat Washers, Hair Pin Cotter and 5/32 x 1-1/2 Cotter Pin.
2. Attach the Arm Weldments to the Front Frame Tube using 5/8-11 U-Bolts and Locknuts. Slide the V-Leveler Bar up to the Arm Weldment and insert Clevis Pin at the highest position that does the required job. Place Flat Washer on Clevis Pin and secure with Hairpin.
3. Adjust V-Leveler Bracket and Arm Weldments, Tighten U-Bolts. **See Figure 2-47.**

Wing V-Leveler Installation

1. Attach the Left and Right Hand Brackets to the Front Wing Frame Tube using 1/2-13 U-Bolts, Lock Washers and Nuts. When the bracket is in position, left and right hand is determined by which side of the bracket the arm projects from. **See Figure 2-45.**
2. Attach the Left and Right Hand Adjustment Angles to the Brackets with 1/2-13 x 1-1/2 Bolts, Lock Washers and Nuts. The hoses mounted on the front of the wing tube may need to be moved and tied down with a cable tie to allow proper mounting of brackets. Do not tighten at this time.
3. Attach the Wing Levelers onto the Adjustment Angles to the highest position that does the required job. Secure with 1/2-13 x 1-1/2 Bolts, Lock Washers and Nuts. Tighten all fasteners.

NOTE

If the soil pushes ahead of the bar it is set too low.

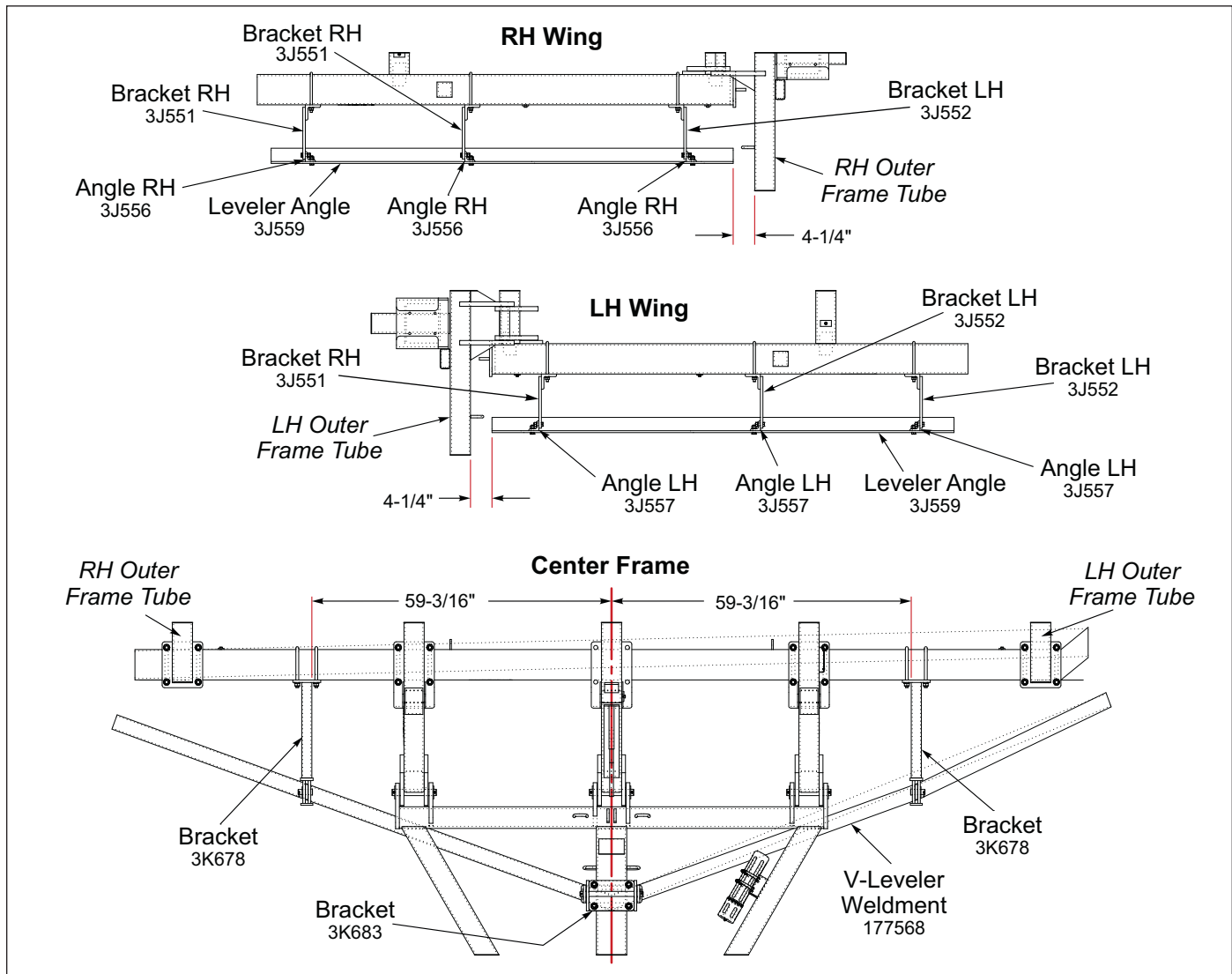

Figure 2-45: V-Leveler Mounting Dimensions - Optional

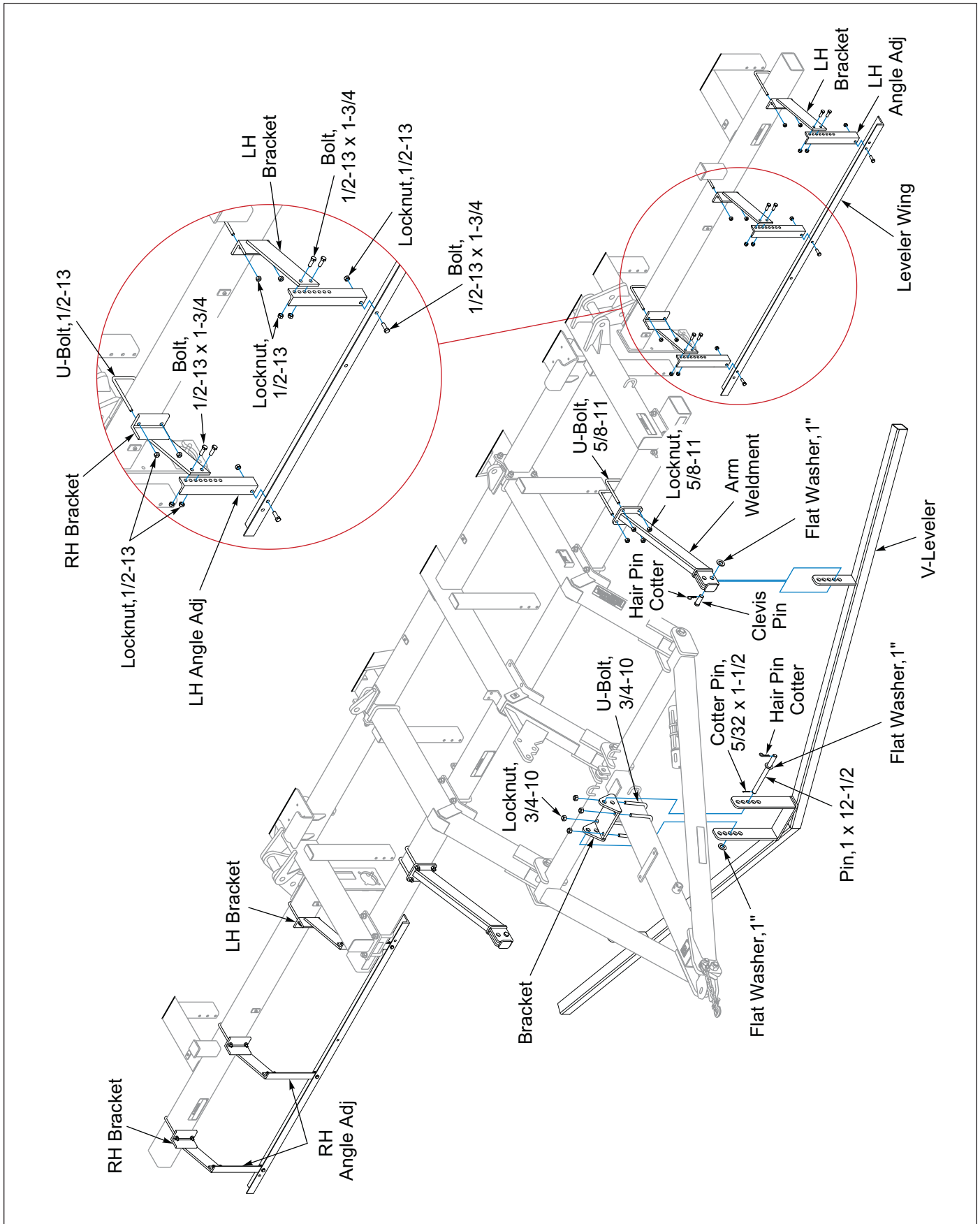

Figure 2-46: V-Leveler Installation - Optional

Rear Hitch Installation - Optional

1. Place the 4 Hole Plate on top on the rear center frame tube, plate should be flush with the end of the tube. **See Figure 2-47.**
2. Position the Hitch Weldment under the rear center frame tube with hitch ear pointing out. Secure the two components using four 3/4-10 x 9 Bolts, Lock Washer, Nuts.
3. Position the Tube Assemblies between the Left and Right Center Rear Frame Tubes.
4. Attach to the Left and Right Frame Tubes using 3/4-10 U-Bolts, Lock Washer and Nuts.
5. Align the two Tube Assemblies on each side of the Center Frame Tube connect using 3/4-10 x 6-1/2 Bolts, Lock Washers and Nuts.
6. Ensure Tubes are aligned, tighten hardware.
7. Rear Hitch Maximum recommended tongue weight is approximately 1,000 pounds.

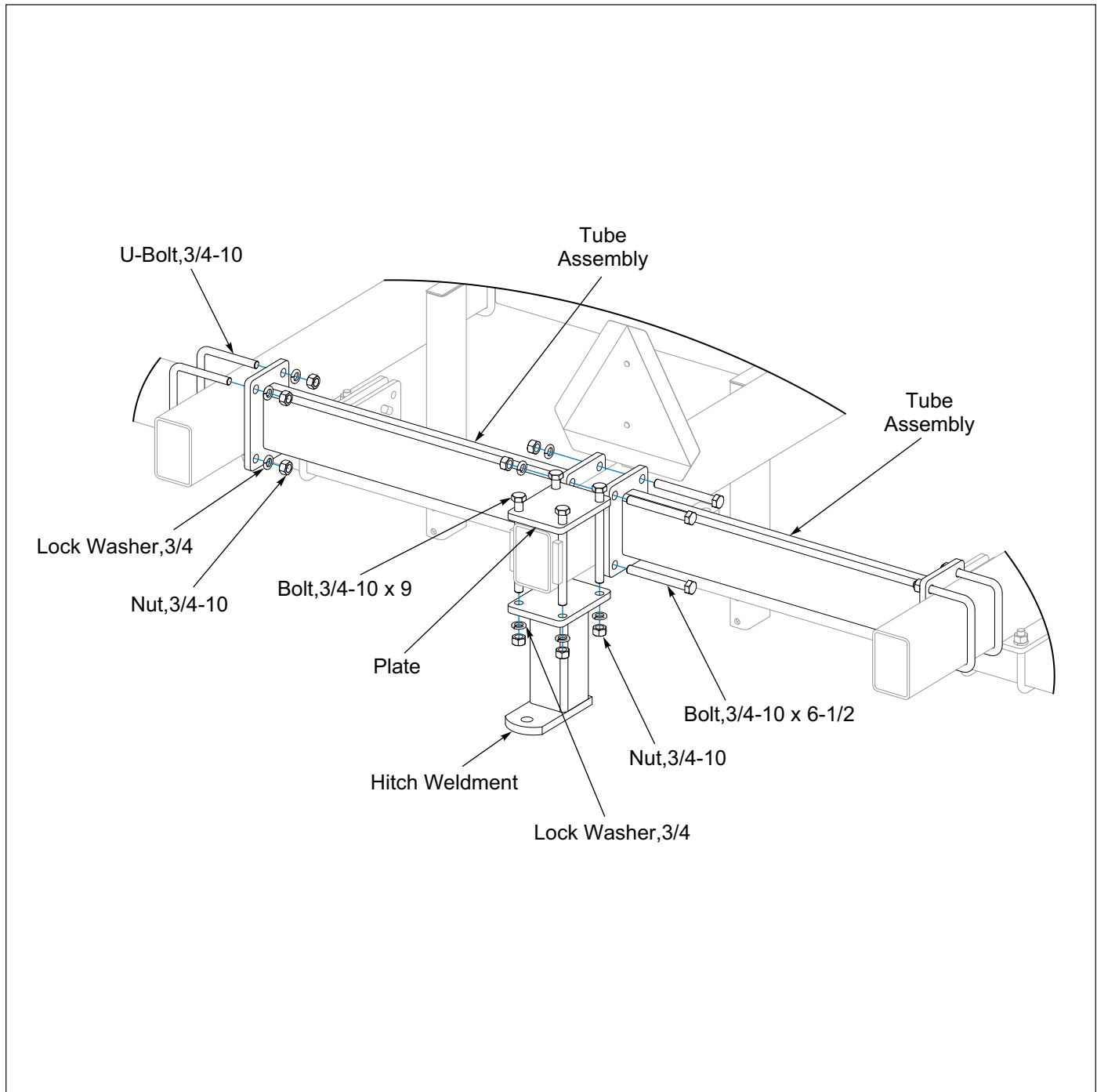

Figure 2-47: Rear Hitch - Optional

**DANGER**

Never allow anyone to ride on the W360 Pulvi-Mulcher at any time. Allowing a person to ride on the machine can inflict serious personal injury or death to that person.

**WARNING**

All hydraulically elevated equipment must have cylinder lockouts installed or be lowered to the ground, when servicing or when equipment is idle. Failure to take preventive measures against accidental lowering can result in serious personal injury.

**CAUTION**

Ensure both Rockshaft Transport Locks are either locked or unlocked. Failure to lock both Transport Locks may result in damage to the machine.

Ensure the Drawbar Transport Lock is unlocked before lowering the machine. Failure to remove the Pin will result in damage to the drawbar and frame.

**CAUTION**

When transporting farm implements on public roads, it is the responsibility of the operator to abide by state and local laws concerning wide loads, speed, safety emblems and safety lighting equipment. Drive at safe speeds, particularly when rounding corners, crossing rough ground or driving on hillsides, to prevent tipping the tractor.

Tractor Preparation

The Brillion Pulvi-Mulcher is designed to be pulled by tractor equipped with a Drawbar with or without a hummer strap. Implement Flip Flop Hitch Spade end is CAT 3 and Clevis end is CAT 2. Optimal Hitch is CAT 3. Before attaching the implement, prepare the tractor as follows:

1. Inflate the rear tractor tires equally and add ballast according to the tractor operator's manual.
2. Lock the Tractor Drawbar in the center position.

Pulvi-Mulcher Preparation

1. Prior to operating the Pulvi-Mulcher, inspect it thoroughly for good operating condition.
2. Replace worn or missing parts.
3. When the machine is new, check the bolt tightness after a few hours of operation. Tighten any loose nuts or bolts. Check the lift wheel lug bolts daily.
4. Check the lift wheel tire inflation. Inflate all tires equally to avoid side draft. Follow the tire manufacturer's recommended pressures listed on the sidewall of the tires.

Attaching to the Tractor

1. Align the tractor drawbar with the machine. Raise or lower the Hitch, as needed, using the Jack. Attach the unit with proper size hitch pin. **See Table 3-1.**
2. Always rotate Jack to its storage position before setting the machine in motion.
3. Clean all hydraulic couplings and attach to the tractor.
4. Fully extend the hydraulic lift wheel cylinders, and place the cylinder lockouts in the Transport Lock Position over the cylinder rods. Secure the lockouts with the lockout pins.
5. Attach Safety Chain to tractor allowing plenty of movement for turning both directions. The safety chain should latch securely to prevent it coming loose. **See Figure 3-1.**
6. Plug in the 7-Pin connector for the lights.
 - Make sure the tractor has a good clean receptacle, free of dirt and corrosion.

- Make sure the 7-Pin connector is inserted ALL the way in. With tighter fitting pins, operator may think the connector is all the way in, but really isn't.
- Make sure the tractor receptacle cover latches over the keyway on the 7-Pin connector to hold the connector in place.
- If an operator plugs in the 7-Pin connector, but the lights do not seem to work right, check the above items to make sure there is a good connection with the 7-Pin connector.

DRAWBAR CAT	Min Pin Size	Max PTO HP
2	1-14" (30mm)	154 (115 Kw)
3	1-1/2" (38mm)	297 (185 Kw)
4	2" (50mm)	402 (300 Kw)

Table 3-1: Hitch Pin Size

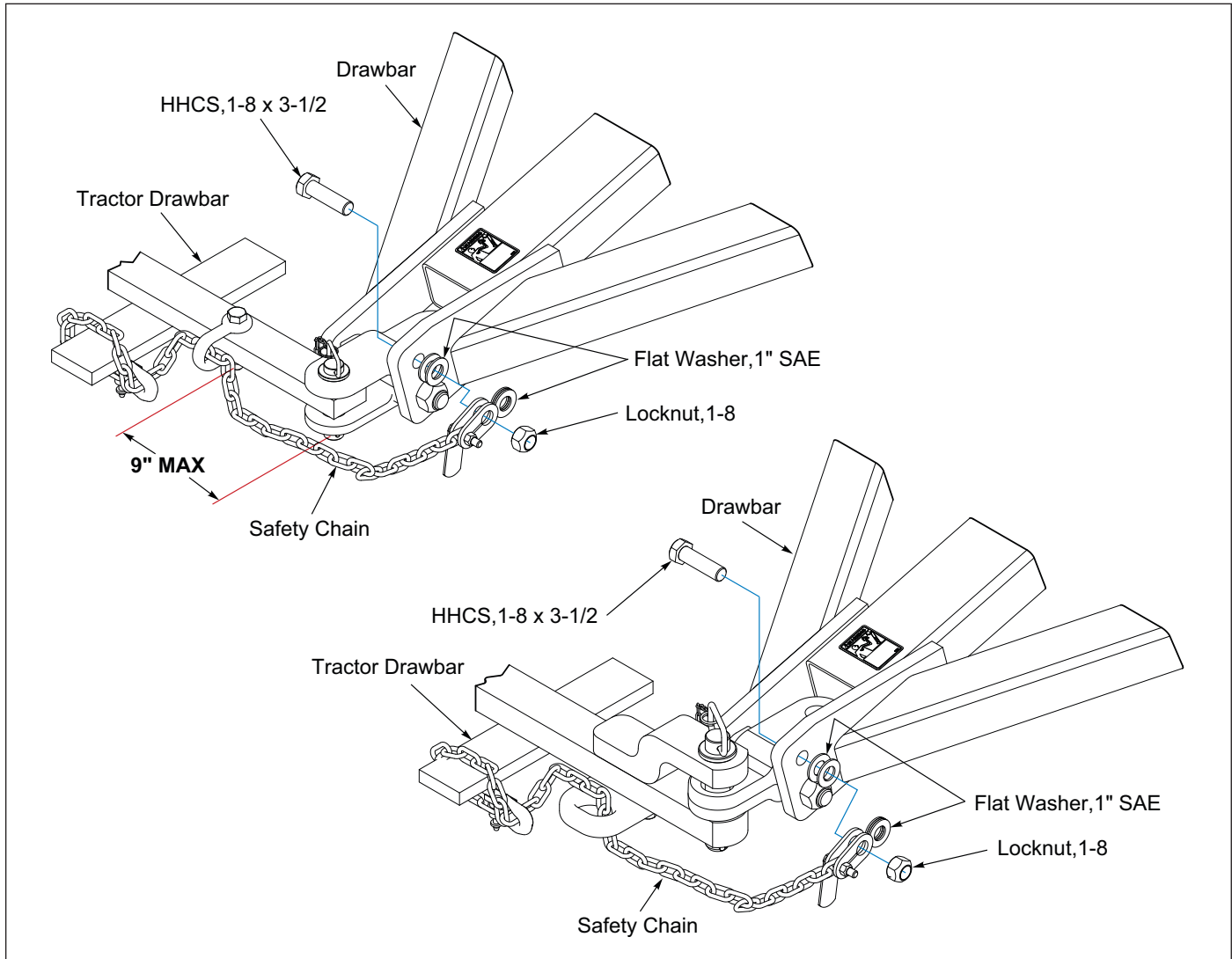

Figure 3-1: Safety Chain To Tractor

Hydraulic Fold System



WARNING

Escaping hydraulic fluid can cause serious personnel injury. Relieve system pressure before repairing, adjusting, or disconnecting. Wear proper hand and eye protection when searching for leaks. Use cardboard instead of hands (See Figure 3-2.) Keep all components (cylinders, hoses, fittings, etc.) in good repair.

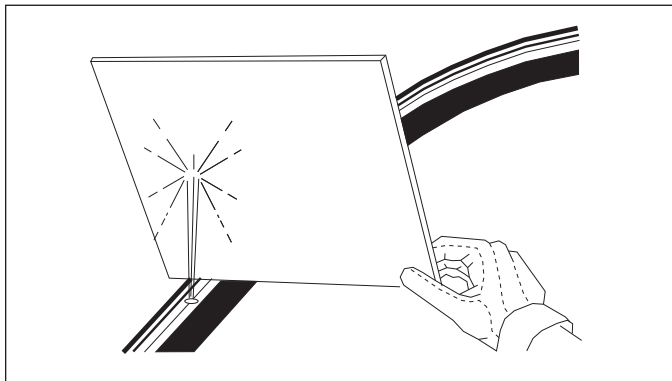

Figure 3-2: Hydraulic Leak Detection

1. The Pulvi-Mulcher is equipped with a hydraulic fold system to raise and lower the wing frames for narrow transport.
2. Be sure the system is fully charged with hydraulic oil before attempting to fold/unfold the unit. Air in the system can allow uncontrolled dropping of the wing frames causing serious personal injury or machine damage. The system needs to be charged with oil initially and any time the system has been opened for repair such as cylinder, hose, or fitting replacement/repair.
3. To charge the system, carefully hitch the Pulvi-Mulcher to a tractor. Unpin the end(s) of the fold cylinders, and position them so the rod end can extend and retract without contacting any frames or other parts. Check the tractor hydraulic fluid level to make sure it is full of the manufacturer's recommended hydraulic fluid. Connect the cylinder hoses to the tractor and fully extend and retract the cylinders 5 or 6 times. The cylinder rod travel should be smooth and positive when all air has been purged from the system. Due to large amounts of hydraulic oil required, recheck the tractor fluid level to make sure it is within proper operating limits.
4. The hydraulic fold system is equipped with restrictors in the cylinders to prevent uncontrolled falling of wing frames when unfolding. Removal or improper assembly of these restrictors can cause the machine to fold improperly and result in serious machine damage.

5. To fold/unfold the Pulvi-Mulcher, find a level area large enough to accommodate the unit when it is fully unfolded. The tractor should be stopped and not moving with the unit fully raised.
6. Slowly engage the tractor lever and fold/unfold the wing frames. When the wings are unfolded, continue holding the tractor lever to fully extend all fold cylinders. This will allow the wings to fully flex in the field.

The Fold Circuit requires approximately 3 gallons of oil.

Hydraulic Lift System

1. The Pulvi-Mulcher is equipped with a hydraulic lift system to raise and lower the unit in the field.
2. Be sure the system is fully charged with hydraulic oil before transporting and field operations. Air in the system can allow uncontrolled dropping of the frame causing serious personal injury or machine damage. The system needs to be charged with oil initially and any time the system has been opened for repair such as cylinder, hose, or fitting replacement/repairs.
3. Check to make sure the tractor hydraulic reservoir is full of the manufacturer's recommended oil.
4. Slowly raise the machine, and continue to hold the hydraulic lever until all lift cylinders are fully extended. Lower and raise the unit to verify that all cylinders are working simultaneously throughout the stroke.
5. Fully extend the lift cylinders and continue to hold the lever until all cylinder rod movement stops.
6. Raise/Lower machine 5 or 6 times to purge air from the system.
7. Do not loosen any hoses or fittings. Recheck tractor reservoir to make sure it is within operating limits.

The Hydraulic Lift Circuit requires approximately 2 gallons of oil.

Hydraulic Tooth Control System

The Puliv-Mulcher is equipped with Hydraulic Tooth Control System which controls the Tines, either full engagement or completely out of the ground.

1. Be sure the system is fully charged with hydraulic oil before raising and lowering the Tines. The system needs to be charged with oil initially and any time the system has been opened for repair such as cylinder, hose, or fitting replacement/repairs.
2. Check to make sure the tractor hydraulic reservoir is full of the manufacturer's recommended oil.
3. Fully extend the Tooth Control Cylinders and continue to hold the lever until all cylinder rod movement stops. Retract and extend the cylinders about 5 or 6 times to purge air from the system to verify that all cylinders are working simultaneously throughout the stroke.
4. Do not loosen any hoses or fittings. Recheck tractor reservoir to make sure it is within operating limits.

Tooth operating depth is controlled by 4 hydraulic cylinders equipped with depth stops. Always raise the machine into the full transport position before operating the machine to release the stop valve and allow the tooth control cylinders to retract to the preset depth. In operation, the transport cylinders must be completely retracted. This in turn retracts the small drawbar cylinder permitting the drawbar to flex and providing the necessary hydraulic pressure to hold the tooth control cylinders in the preset position.

The Tooth Control Circuit requires approximately 1-1/2 gallons of oil.

General Operation

1. The minimum horsepower requirements are typically 6-8 horsepower per foot. This will vary widely due to speed, depth, moisture, residue and types of soils. Local dealers can help in making recommendations for your areas.
2. Operating speed is typically 5-8 mph. Excessive speed can cause rapid sweep/point wear. Reduce speed in rocky conditions to prevent wheel breakage.
3. Lift wheels must always be in raised position. It is not necessary to raise machine up on transport wheels during turns. Pulverizer wheels are used to gauge the depth of each frame section.
4. Do not turn with the teeth in the ground, this can put excessive side load on the Tines. Raise the Tines slightly using hydraulic tooth control when making turns to prevent bent or broken Tines, additionally excessive side load can also bend the Tine Tubes.
5. Allow just enough looseness so each wheel will turn by itself. If wheels become worn, loosen the clamp at the end of each roller axle and tighten as needed. **See Figure 4-2.**
6. Always raise and lower the Wings with the machine raised into transport position to ease the side load on the roller bearings and the end roller clamps.

Rockshaft and Drawbar Transport Locks



CAUTION

Ensure both Rockshaft Transport Locks are either locked or unlocked. Failure to lock both Transport Locks may result in damage to the machine.

Ensure the Drawbar Transport Lock is unlocked before lowering the machine. Failure to remove the Pin will result in damage to the drawbar and frame.

Road to Field

1. With machine still raised fully, unfold wings.
2. Remove Drawbar Transport Lock Clevis Pin and Hair Pin and place it in the storage position in the Frame Lug top hole.
3. Raise machine slightly to loosen Rockshaft Transport Lock Clevis Pin. Remove Clevis Pin from slot and insert it into the storage hole located above the slot in the Rear Frame Tube Lugs. Insert Hair Pin.

Field to Road

1. Raise machine fully, fold wings.
2. Remove Rockshaft Transport Lock Clevis Pin from storage hole located above the slot in the Rear Frame Tube Lugs. With Flat Washers on both sides of the slot, insert Clevis Pin into Lug slot and through the Transport Lock hole. Insert Hair Pin.
3. Remove Drawbar Transport Lock Clevis Pin and Hair Pin for storage position in the Frame Lug and place it in the top hole of the drawbar side plate. **See Figures 3-3 and 3-4.**

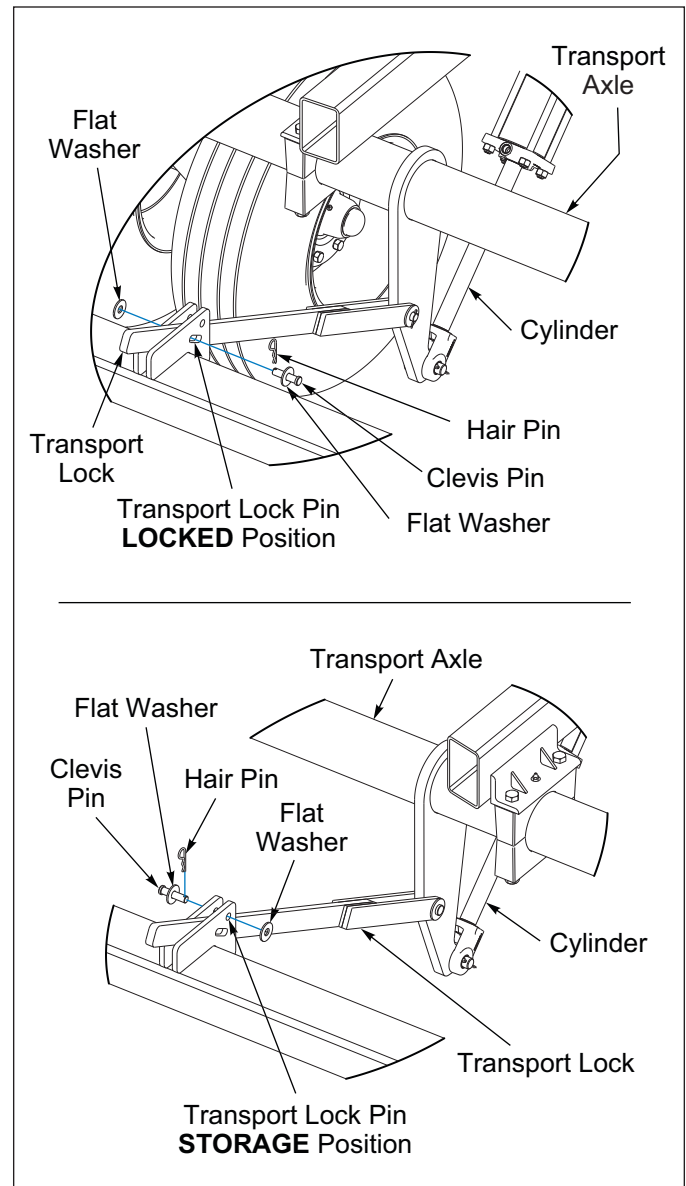

Figure 3-3: Transport Lock

Drawbar Transport Lock

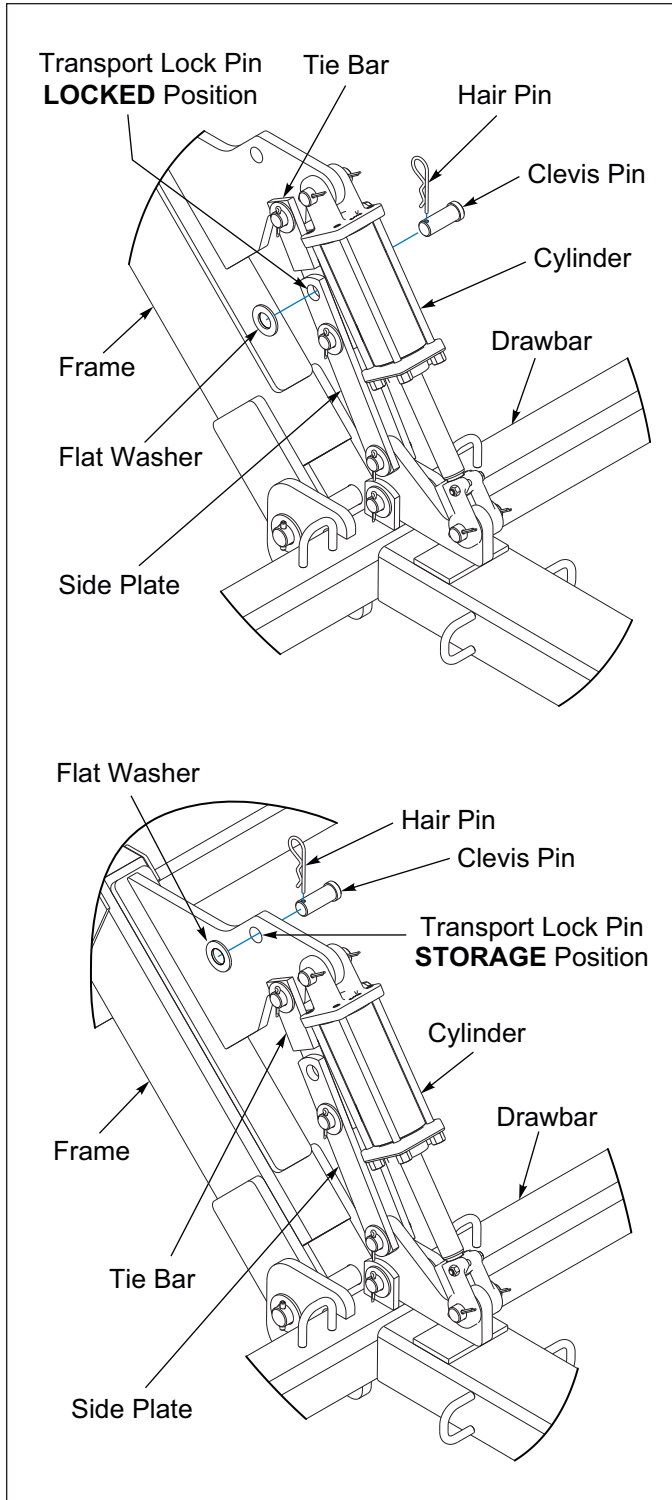

Figure 3-4: Drawbar Transport Lock Positions

Scraper Adjustment

The Pulvi-Mulcher, if equipped with Notched Rear Wheels will have scrapers. To adjust scrapers; lower machine on level surface. Adjust scrapers to 1/4" gap between scraper and wheel.

NOTE

Scrapers are optional on notched front rollers. Adjustment procedure is the same for the front.

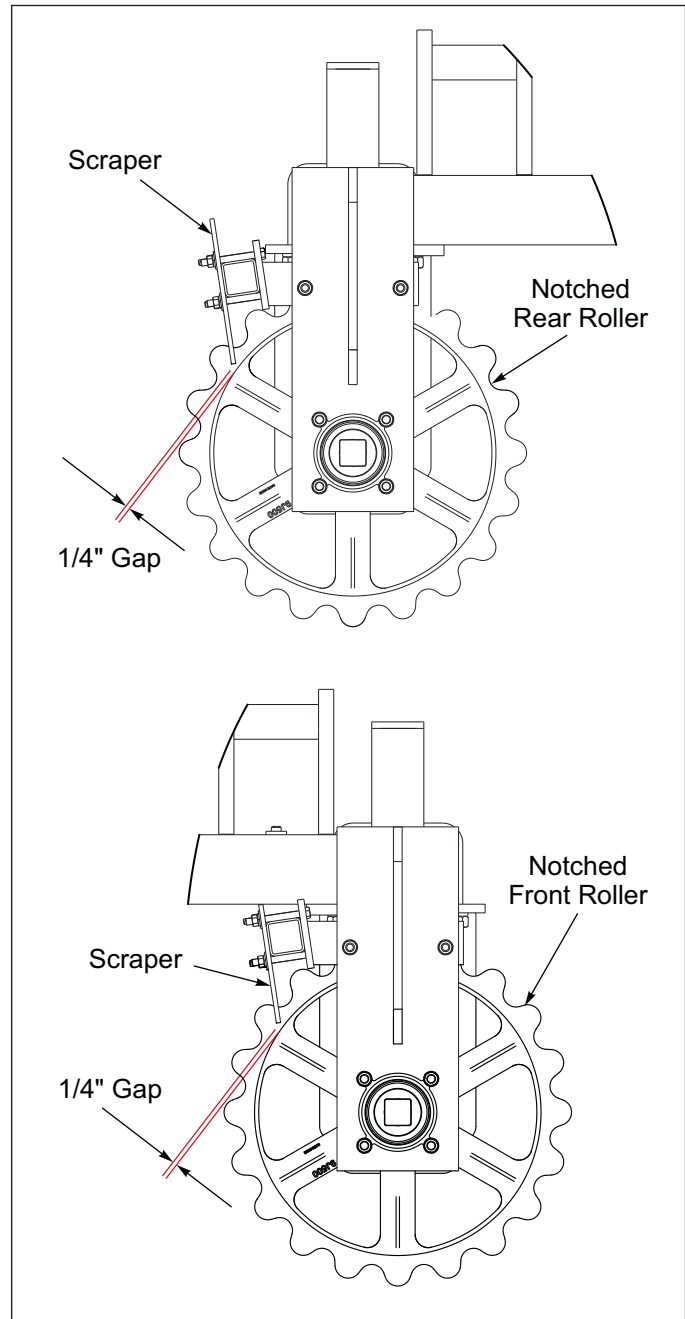

Figure 3-5: Scraper Adjustment

Transport

1. Check and follow all federal, state, and local requirements before transporting the Pulvi-Mulcher.
2. The Pulvi-Mulcher should be transported only by tractor required for field operation. The implement weight should not exceed more than 1.5 times the tractor weight. Maximum transport speed for the Pulvi-Mulcher is 20 mph for the implement and is designated on the speed identification symbol located on the front of the implement.

! CAUTION

Excessive speed may result in loss of control of the tractor and implement, reduced braking ability, or failure of the implement tire or structure. Do not exceed the implement maximum specified ground speed regardless of the capability of the maximum tractor speed.

3. When towing equipment in combination, the maximum equipment ground speed shall be limited to the lowest specified ground speed of any of the towed implements.
4. Maximum transport speed shall be the lesser of travel speed specified in the operator's manual, speed identification symbol, information sign of towed equipment, or limit of road conditions.
5. Slow down when driving on rough roads. Reduce speed when turning, or on curves and slopes to avoid tipping. Equipment altered other than the place of manufacture may reduce the maximum transport speed. Additional weight, added tanks, harrowing attachments, etc. may reduce implement load carrying capabilities.
6. A Safety Chain is provided with the implement to insure safe transport. **See Figure 3-1.**
 - The Safety Chain should have a tensile strength equal to or greater than the gross weight of the implement. The chain is attached to the lower hitch clevis hole with two Flat Washers between the clamp plates to assure a tight connection. Always use a 1" diameter Grade 8 bolt for this connection.
 - Attach the Safety Chain to the Tractor Drawbar. Provide only enough slack in the chain for turning. Do not use an intermediate chain support as the attaching point for the chain on the tractor. Do not pull the implement by the Safety Chain.
 - Regularly inspect the Safety Chain for worn, stretched, or broken links and ends. Replace the Safety Chain if it is damaged or deformed in any way.
7. Check that tires are of proper size, load rating, and inflated to manufacture specifications before transporting. Check wheel lug bolts to ensure tightness.

8. Know the transport heights and widths of the unit before transporting. Use caution when transporting near bridges and power lines.

! WARNING

Electrocution can occur without direct contact.

9. Raise the machine to full transport height.
10. Install transport locks on lift systems. Do not depend solely on implement hydraulics for transport. **See Figure 3-3.**

! WARNING

Failure to use transport lock pins during transport may result in permanent equipment damage, serious injury or death.

11. Transport during daylight hours when ever possible. Always use flashing warning lights, except where such use is prohibited by law. Make sure lights, reflectors and SMV emblem are clearly visible and operating. Remove any obstructions such as dirt, mud, stalks or residue that restricts view before transporting.

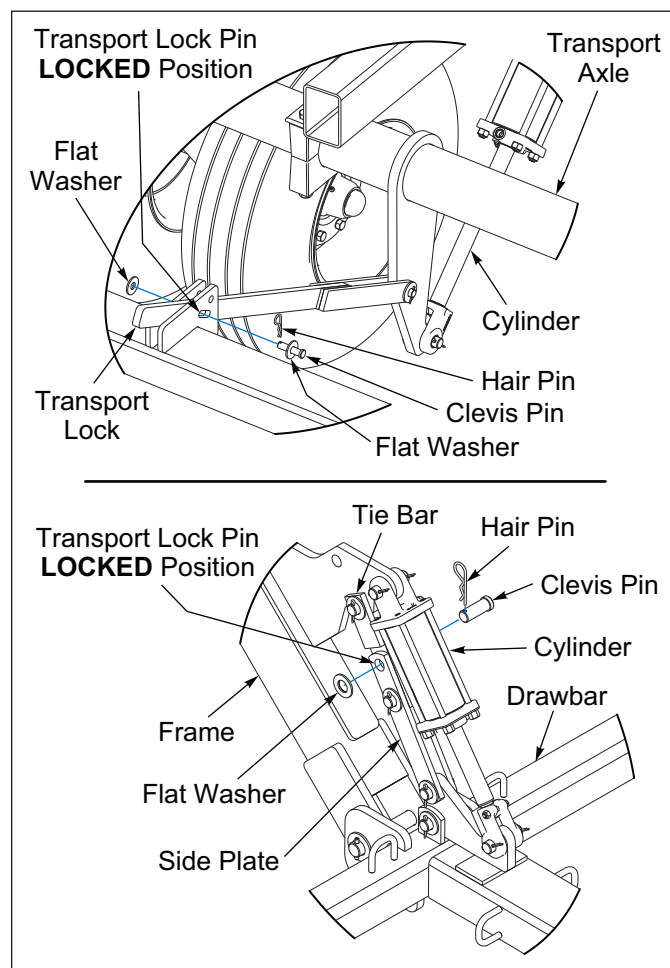

Figure 3-6: Rockshaft and Drawbar Transport Locks in Locked Position

Land and V-Leveler Adjustment - Optional

Adjust the leveler bar to the highest position that does the required job. Its purpose is to break up and scatter any large lumps that are above the normal ground level. See **Figure 3-7**.

If soil pushes ahead of the bar, it is set too low. Striking large rocks will damage the leveler bar and possibly other parts of the machine.

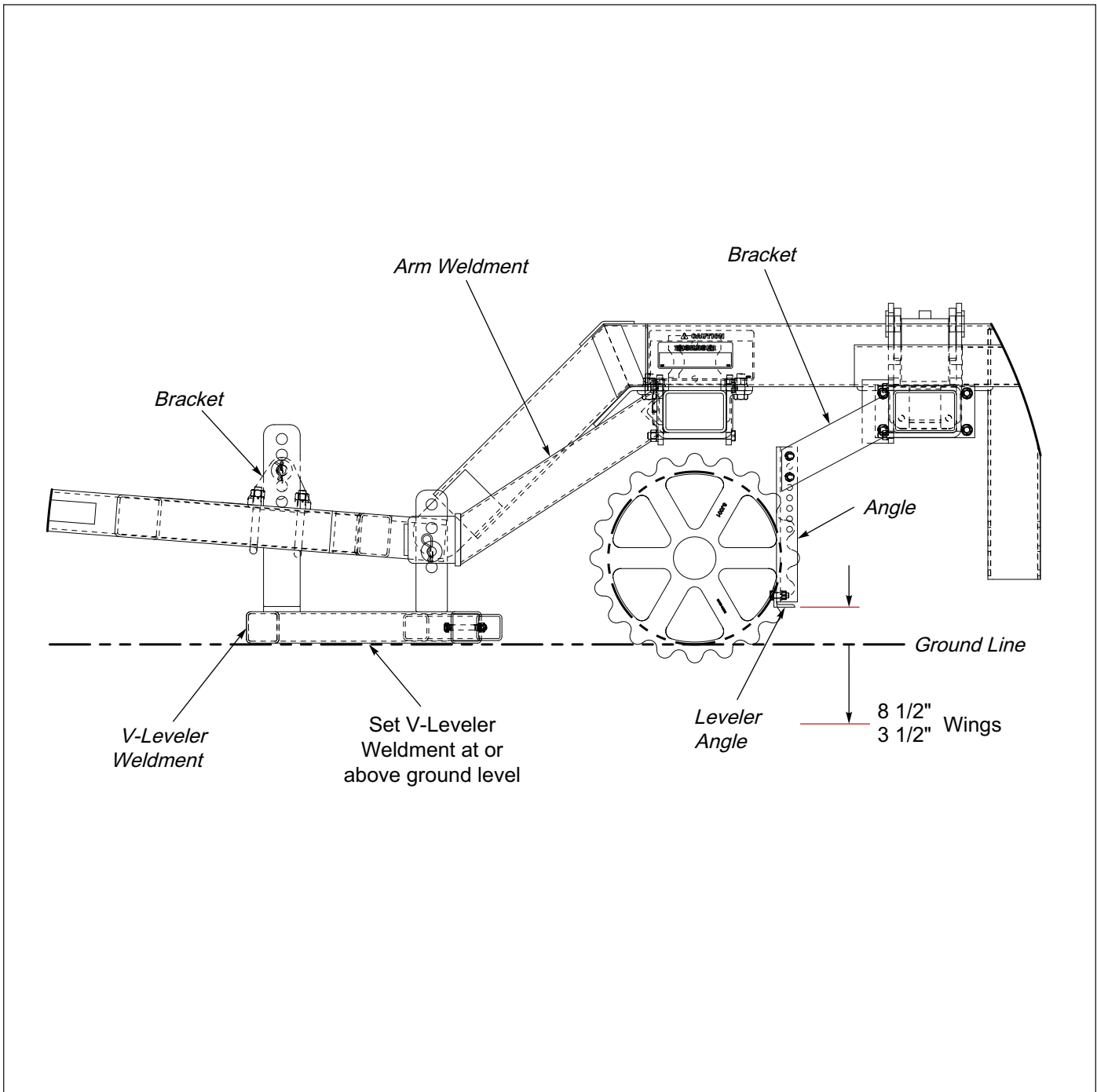

Figure 3-7: Leveler Adjustment

General Torque Specifications

(rev. 4/97)

This chart provides tightening torques for general purpose applications when special torques are not specified on process or drawing. Assembly torques apply to plated nuts and capscrews assembled without supplemental lubrication (as received condition). They do not apply if special graphite moly-disulfide or other extreme pressure lubricants are used. When fasteners are dry (solvent cleaned) add 33% to as received condition torque. Bolt head identification marks indicate grade and may vary from manufacturer to manufacturer. Thick nuts must be used on Grade 8 capscrews. Use value in [] if using prevailing torque nuts.

TORQUE SPECIFIED IN FOOT POUNDS

UNC SIZE	SAE Grade 2	SAE Grade 5	SAE Grade 8	UNC SIZE	SAE Grade 2	SAE Grade 5	SAE Grade 8
1/4-20	4 [5]	6 [7]	9 [11]	1/4-28	5 [6]	7 [9]	10 [12]
5/16-18	8 [10]	13 [13]	18 [22]	5/16-24	9 [11]	14 [17]	20 [25]
3/8-16	15 [19]	23 [29]	35 [42]	3/8-24	17 [21]	25 [31]	35 [44]
7/16-14	24 [30]	35 [43]	55 [62]	7/16-20	27 [34]	40 [50]	60 [75]
1/2-13	35 [43]	55 [62]	80 [100]	1/2-20	40 [50]	65 [81]	90 [112]
9/16-12	55 [62]	80 [100]	110 [137]	9/16-18	60 [75]	90 [112]	130 [162]
5/8-11	75 [94]	110 [137]	170 [212]	5/8-18	85 [106]	130 [162]	180 [225]
3/4-10	130 [162]	200 [250]	280 [350]	3/4-16	150 [188]	220 [275]	320 [400]
7/8-9	125 [156]	320 [400]	460 [575]	7/8-14	140 [175]	360 [450]	500 [625]
1-8	190 [237]	408 [506]	680 [850]	1-14	210 [263]	540 [675]	760 [950]
1-1/8-7	270 [337]	600 [750]	960 [1200]	1-1/8-12	300 [375]	660 [825]	1080 [1350]
1-1/4-7	380 [475]	840 [1050]	1426 [1782]	1-1/4-12	420 [525]	920 [1150]	1500 [1875]
1-3/8-6	490 [612]	1010 [1375]	1780 [2225]	1-3/8-12	560 [700]	1260 [1575]	2010 [2512]
1-1/2-6	650 [812]	1460 [1825]	2360 [2950]	1-1/2-12	730 [912]	1640 [2050]	2660 [3325]

METRIC:

Coarse thread metric class 10.9 fasteners and class 10.0 nuts and through hardened flat washers, phosphate coated, Rockwell "C" 38-45. Use value in [] if using prevailing torque nuts.

Nominal thread diameter (mm)	Newton Meters (Standard Torque)	Foot Pounds (Standard Torque)	Nominal Thread Diameter (mm)	Newton Meters (Standard Torque)	Foot Pounds (Standard Torque)
6	10 [14]	7 [10]	20	385 [450]	290 [335]
7	16 [22]	12 [16]	24	670 [775]	500 [625]
8	23 [32]	17 [24]	27	980 [1105]	730 [825]
10	46 [60]	34 [47]	30	1330 [1470]	990 [1090]
12	80 [125]	60 [75]	33	1790 [1950]	1340 [1450]
14	125 [155]	90 [115]	36	2325 [2515]	1730 [1870]
16	200 [240]	150 [180]	39	3010 [3210]	2240 [2380]
18	275 [330]	205 [245]			

Hydraulic Fitting Torque Specifications

37 degree JIC, ORS, &ORB (REV. 10/97)

This chart provides tightening torques for general purpose applications when special torques are not specified on process or drawing. Assembly torques apply to plated nuts and capscrews assembled without supplemental lubrication (as received condition). They do not apply if special graphite moly-disulfide or other extreme pressure lubricants are used. When fasteners are dry (solvent cleaned) add 33% to as received condition torque. Bolt head identification marks indicate grade and may vary from manufacturer to manufacturer. Thick nuts must be used on Grade 8 capscrews. Use value in [] if using prevailing torque nuts.

TORQUE SPECIFIED IN FOOT POUNDS

PARKER® BRAND FITTINGS

Dash Size	37 Deg. JIC	O-ring (ORS)	O-ring boss
-4	11-13	15-17	13-15
-5	14-16	-----	21-23
-6	20-22	34-36	25-29
-8	43-47	58-62	40-44
-10	55-65	100-110	58-62
-12	80-90	134-146	75-85
-16	115-125	202-218	109-121
-20	160-180	248-272	213-237
-24	185-215	303-327	238-262
-32	250-290	-----	310-340

GATES® BRAND FITTINGS

Dash Size	37 Deg. JIC	O-ring (ORS)	O-ring boss
-4	10-11	10-12	14-16
-5	13-15	-----	-----
-6	17-19	18-20	24-26
-8	34-38	32-40	37-44
-10	50-56	46-56	50-60
-12	70-78	65-80	75-83
-14	-----	65-80	-----
-16	94-104	92-105	111-125
-20	124-138	125-140	133-152
-24	156-173	150-180	156-184
-32	219-243	-----	-----

AEROQUIP® BRAND FITTINGS

Dash Size	37 Deg. JIC	O-ring (ORS)	O-ring boss
-4	11-12	10-12	14-16
-5	15-16	-----	16-20
-6	18-20	18-20	24-26
-8	38-42	32-35	50-60
-10	57-62	46-50	75-80
-12	79-87	65-70	125-135
-14	-----	-----	160-180
-16	108-113	92-100	200-220
-20	127-133	125-140	210-280
-24	158-167	150-165	270-360

Fasteners

Before operating your Brillion machine, check all hardware for tightness. Use the Tightening Torque Table as a guide. **See Page 4-1.**

After a few hours of use, check entire machine and tighten any loose nuts or bolts. Daily or periodic checks should be made thereafter.

When replacing bolts, be sure to use fasteners of equal grade.

Wheel Bearing Maintenance

Wheel Bearing Maintenance should be performed at the beginning of every season of use. Check the Wheel Bearings periodically for excessive end play.

Hydraulic Maintenance

IMPORTANT

Unfold, lower the unit to the ground, and relieve hydraulic pressure before attempting to service any hydraulic component.

1. Check the tractor hydraulic fluid level per tractor owners manual and after any leakage. Check fluid level with the cylinders in the retracted position.
2. If a cylinder or valve leaks, disassemble the parts to determine the cause of the leak. Any time a cylinder is opened up, or whenever any seal replacement is

necessary, it is advisable to clean all parts and replace all seals. Seal kits are available from your Brillion dealer.

3. Check all hydraulic hoses weekly. Look for binding or cracking. Replace all worn or defective parts immediately.
4. Transport locks are provided to hold the implement in a raised position. **See Figure 4-1.** Do not attempt to perform any service work under the implement without first installing the transport locks. Before servicing any hydraulic component, lower the implement to the ground and relieve all system pressure. If a hydraulic component is disconnected, repaired, or replaced, it will be necessary to purge the system of air before operation. **See “Purging the Hydraulic Wing Fold, Transport and Tooth Control Cylinders” on page 2-26** on how to purge the hydraulic systems.

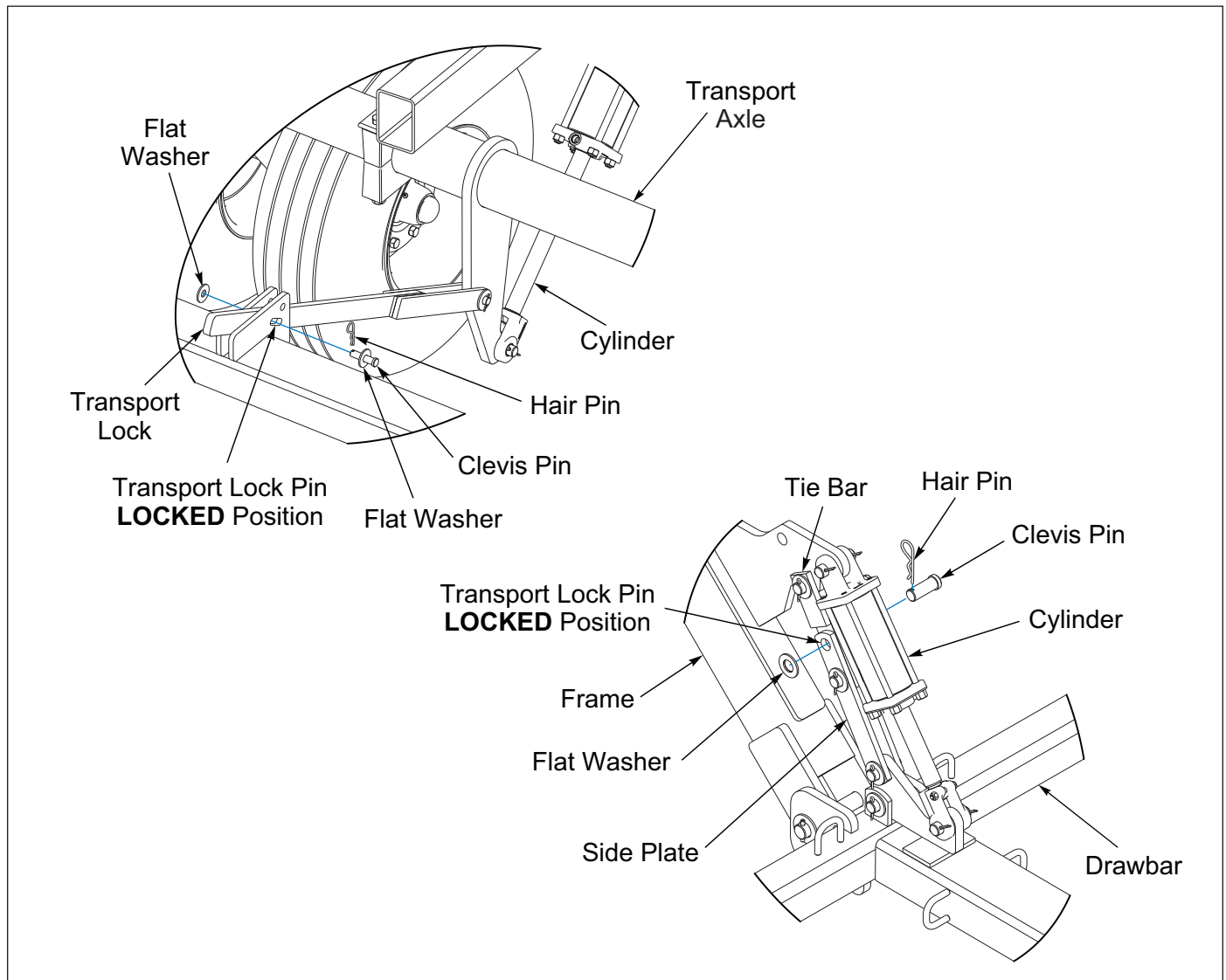

Figure 4-1: Transport Locks in Locked Position

Roller Axle Wheels

After an initial run of 5-10 hours, check the Roller Axle Assemblies to insure that the wheels are tight to one another. Allow just enough looseness so each wheel will turn by itself. If not slide the wheels tight together and adjust the Axle Clamps. Thereafter check assemblies every 50-100 hours.

Clamp Tightening Procedure:

The tightening procedure and torque requirement is critical in keeping the clamp tight.

1. Check axle and clamp for burrs on mating surfaces.
2. Remove end play between wheels by sliding wheels toward the fixed end of the axle.
3. Position clamp snugly against the end wheel.
4. Tighten the U-bolt evenly to 57 ft/lbs (U-bolt must be tightened first.) **See Figure 4-2.**
5. Tighten set screws to 37 ft/lbs

The torque requirement is recommended for axles without internal bearings, but is not critical.

Axle Installation:

When installing a roller axle with an internal bearing onto a support bracket, it is important to keep the roller axle aligned as straight as possible to the installed position. If the roller assembly is significantly out of line when sliding it onto a fixed support, the inner race of the bearing may crack and cause premature bearing failure.

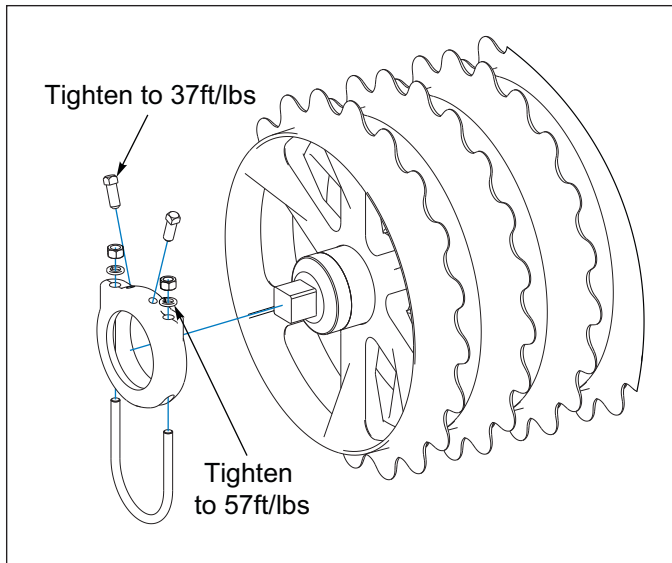

Figure 4-2: Axle Clamp

Lubrication Maintenance

Grease Transport Axles four bearing sets. Fitting are on the top and on the bottom bearing halves.

Grease wheel bearing and repack them annually. **See Figure 4-3.**

Pulvi-Mulcher axle roller bearings are sealed with a triple lip seal and are non-lubricable.

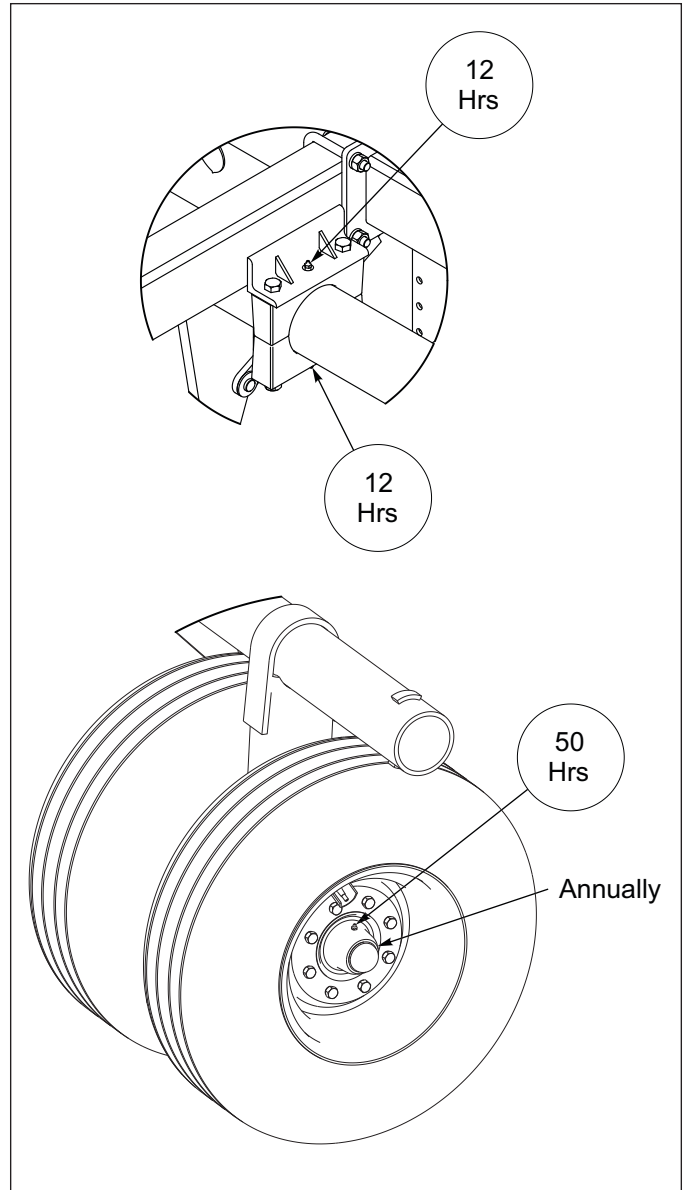

Figure 4-3: Lubrication

Tires

Pulvi-Mulcher machines are supplied with 320/70R15 Tires and should be inflated to 70 PSI.

When Re-Installing the Wheel Bolts tighten to 50 foot-pounds using the sequence in **Figure 4-4**. Then tighten to full torque of 90-100 ft-lbs. It is good maintenance practice to lubricate the wheel bolts prior to inserting.

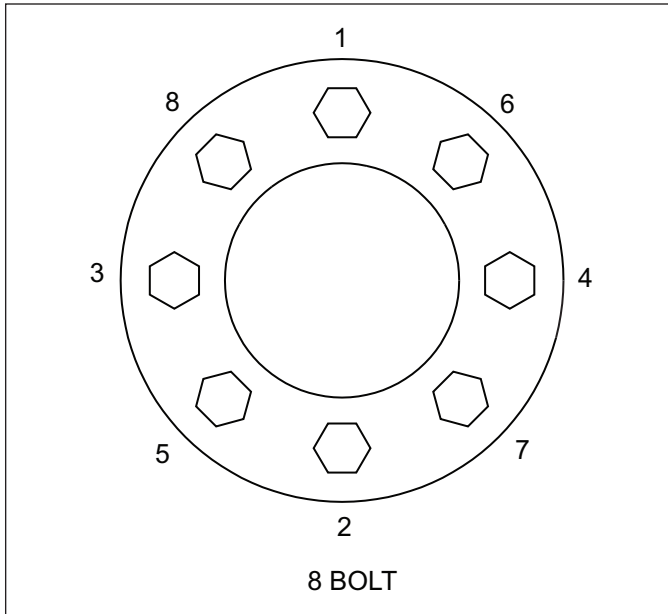

Figure 4-4: Stud Tightening Sequence

Warning Lamps

When plugging in the 7-Pin Warning Lamp Connector:

1. Make sure the Tractor has a good clean Receptacle, free of dirt and corrosion. **See Figure 4-5.**
2. Make sure the 7-Pin Connector is inserted ALL the way in. With tighter fitting pins, operator may think the Connector is all the way in, but really isn't.
3. Make the sure the Tractor Receptacle Cover latches over the keyway of the 7-Pin Connector to hold the Connector in place.

If an operator plugs in the 7-Pin Connector, but the lights Do Not seem to work right, check the above items to make sure there is a good condition with the 7-Pin Connector.

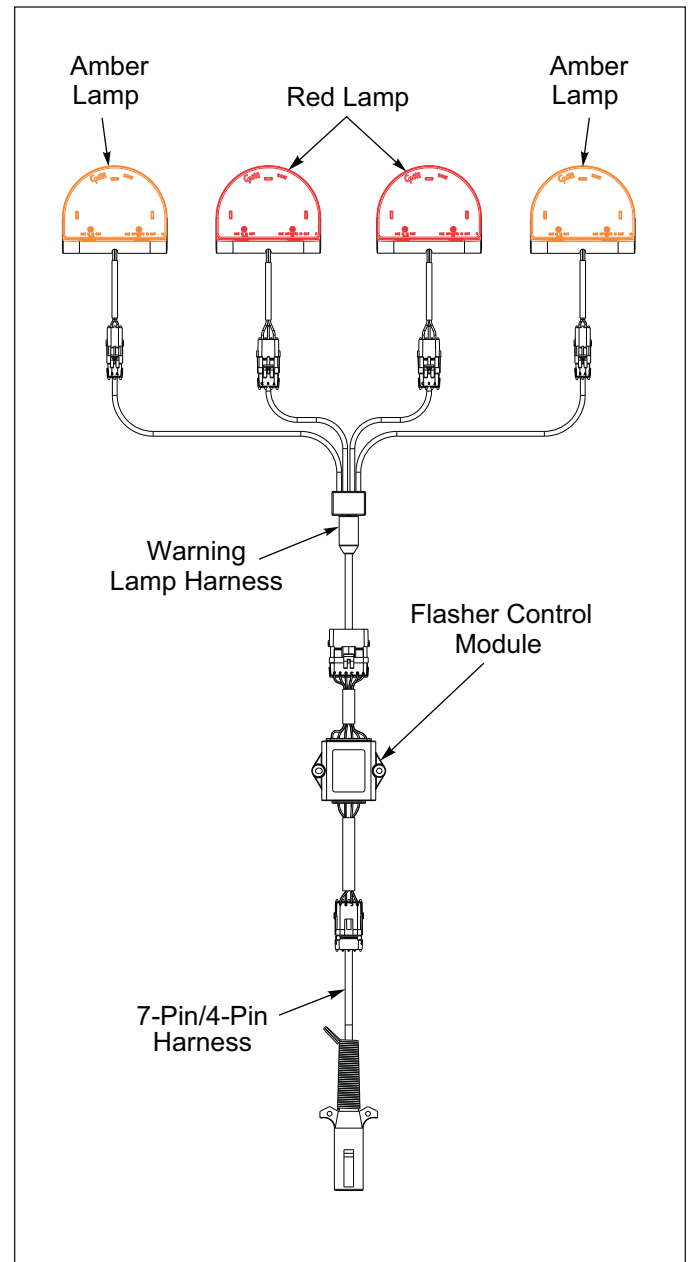

Figure 4-5: Warning Lamps

Storage

1. The service life of the Pulvi-Mulcher will be extended by proper off-season storage practices. Prior to storing the unit, complete the following procedures:
 - a. Completely clean the unit.
 - b. Inspect the machine for worn or defective parts. Replace as needed.
 - c. Repaint all areas where the original paint is worn off.
 - d. Apply a light coating of oil or grease to exposed cylinder rods to prevent them from rusting.
 - e. Grease Transport Axle Bearings and Wheel bearings. **See Figure 4-3.**
2. Store the unit in a shed or under a tarpaulin to protect it from the weather. The ground tools and tires should rest on boards, or some other object, to keep them out of the soil.
3. When the unit is stored in the raised position, make sure the Transport Locks are installed to prevent settling.
4. Relieve Hydraulic Pressure in hoses after Transport Locks are installed.
5. Block wheels before unhitching from tractor.

Maintenance Chart

(Subject to change without notice)

	Initial Run-In	20 Hours	50 Hours	100 Hours/Annually	Storage
Fasteners, Wheel Hub Bolts	X			X	
Adjust Scraper if equipped			X		
Grease Wheel Hub			X	X	
Repack Wheel Hub Bearings				X	
Tighten RollerAxle Wheels and Clamps			X	X	
** Clean machine					X
Grease after cleaning					X
Touch-up paint					X

*** Avoid spraying high pressure washer directly at bearing seals and electrical connections.*

Table 4-1: Maintenance Chart

Specifications

Model Designation

Basic model is “WL” indicating Wing Mulcher having frame for Large diameter (20") ductile packer wheels.

“CL” - Crowfoot Wheels Front and Notched Wheels Rear

“LC” - Notched Wheel Front and Crowfoot Wheels Rear

“CC” - Crowfoot Wheels Front and Rear

“S” indicates S-Tines; otherwise C-Teeth are used.

First three digits of numbers are rolling width in inches: 360 = 30' 0".

Accessories & Optional Equipment

PART NUMBER	DESCRIPTION
2J149	1-3/8" Heavy-Duty Reversible S-Tine Point with Hardware
2J150	2-3/4" Shovel with Hardware for S-Tines
3K028	S-Tine Shank, Clamp & Hardware
9J619	Front Scraper Kit for 30' Models (For Notched Rollers)
9J614	Land Leveler Kit for 30' Models
177563	V-Leveler Kit for 30' Models
9J545	Rear Hitch Kit
9K010	Independent Wing Fold Hydraulic Plumbing Kit (Allows Separate Machine Lift and Tooth Control Hydraulic Circuits) [Three Hydraulic Circuits Required for Independent Machine Raising/Lowering and Wing Folding]

Hydraulic Fluid Capacities

Wing Fold Circuit: 3 Gallons

Lift Circuit: 2 Gallons

Tooth Control Circuit: 1-1/2 Gallons

Model Specifications

Product Attributes	WL-360, WLC-360, WCL-360, WCC-360	WLS-360, WLCS-360, WCLS-360, WCCS-360
Approximate Weight	WL-360: 15,453 lbs. (7,009 kg) WLC-360: 14,836 lbs. (6,729 kg) WCL-360: 15,189 lbs. (6,890 kg) WCC-360: 14,572 lbs. (6,610 kg)	WLS-360: 15,377 lbs. (6,975 kg) WLCS-360: 13,961 lbs. (6,333 kg) WCLS-360: 14,313 lbs. (6,492 kg) WCCS-360: 13,697 lbs. (6,213 kg)
Working Width	30 ft. 0 in. (9.0 m)	30 ft. 0 in. (9.0 m)
Transport Width	16 ft. 9 in. (5.0 m)	16 ft. 9 in. (5.0 m)
Transport Height	6 ft. 4 in. (1.9 m)	6 ft. 4 in. (1.9 m)
Overall Length (Transport)	19 ft. 10 in. (6.0 m)	19 ft. 10 in. (6.0 m)
Road Clearance	10 in. (254 mm)	10 in. (254 mm)
Pulverizer Wheels - Front		
Type of Wheel	WL-360/WLC-360: 20 in. (500 mm) Notched Ductile Iron WCL-360/WCC-360: 20 in. (500 mm) Crowfoot Ductile Iron	WLS-360/WLCS-360: 20 in. (500 mm) Notched Ductile Iron WCLS-360/WCCS-360: 20 in. (500 mm) Crowfoot Ductile Iron
Number of Wheels	WL-360/WLC-360: 88 WCL-360/WCC360: 60	WLS-360/WLCS-360: 88 WCLS-360/WCCS-360: 60
Pulverizer Wheels - Rear		
Type of Wheel	WL-360/WCL-360: 20 in. (500 mm) Notched Ductile Iron WLC-360/WCC-360: 20 in. (500 mm) Crowfoot Ductile Iron	WLS-360/WCCS-360: 20 in. (500 mm) Notched Ductile Iron WLCS-360/WCCS-360: 20 in. (500 mm) Crowfoot Ductile Iron
Number of Wheels	WL-360/WCL-360: 89 WLC-360/WCC-360: 60	WLS-360/WCLS-360: 89 WLCS-360/WCCS-360: 60
Rear Roller Scrapers		
Roller Axle Size	Standard on WL-360 & WCL-360 4 in. (102 mm)	Standard on WLS-360 & WCLS-360 4 in. (102 mm)
Bearing Type	1.5 in. (38 mm) Square Bore Bearing with Triple Lip Seal	1.5 in. (38 mm) Square Bore Bearing with Triple Lip Seal
Type of Shanks	Conventional C Teeth	12 mm S-Tine Teeth with 1.38 in. (35 mm) Reversible Point or 2.75 in. (70 mm) Shovel
Number of Shanks	59	59
Nominal Shank Spacing	6 in. (153 mm)	6 in. (153 mm)
Maximum Shank Depth of Operation	6 in. (153 mm)	6 in. (153 mm)
Hitch	Pull-Type with Hydraulic Lift	Pull-Type with Hydraulic Lift
Hitch Category	Cat. II, III (Cat. IV Available)	Cat. II or III (Cat. IV Available)
Tire Size	(4) 12.5L x 16-14 Ply Tires	(4) 12.5L x 16-14 Ply Tires
Hydraulic Circuits Required	3 (+1 for Rear Hitch)	3 (+1 for Rear Hitch)
Rear Hitch	Optional	Optional
Front Roller Scraper Kit (Notched Rollers)	Optional on WL-360 & WLC-360	Optional on WLS-360 & WLCS-360
Land Leveler Kit	Optional	Optional
V-Leveler Kit	Optional	Optional
Independent Hydraulic Tooth Control	Standard	Standard
LED Warning Lights and SMV Emblem	Standard	Standard
Safety Chain Kit	Standard	Standard
Powder Coat Paint	Standard	Standard
Horsepower Requirements	6 to 8 HP (4.5 to 6 kW) per ft.	6 to 8 HP (4.5 to 6 kW) per ft.
Recommended Operating Speed	3 to 6 MPH (5 to 10 km/h)	3 to 6 MPH (5 to 10 km/h)

Specifications subject to change with or without notice.

Table 5-1: Model Specifications

Document Control Revision Log:

Date	Form #	Improvement(s): Description and Comments
	190rev10-03-05	
11/2007	190rev1107	Updated Manual
05/2012	190rev0512	Improved Drawings, Translated to Landoll Format
12/2014	190rev1214	Improved Drawings, added Engineering Changes
01/2017	190rev0117	Added LED Warning Lights
03/2007	9J577-0307	
08/2022	9J577-0822	ECN 48308 - Tire and Wheel Asm Added QR Code



Intertek

Equipment from Landoll Company, LLC is built to exacting standards ensured by ISO 9001 registration at all Landoll manufacturing facilities.

WL360 Folding Pulvi-Mulcher Models: WL,WLS,WCL,WCLS, WLC,WLCS,WCC and WCCS

Operator's Manual

Re-Order Part Number 9J577

LANDOLL COMPANY, LLC

1900 North Street

Marysville, Kansas 66508

(785) 562-5381

800-428-5655 ~ WWW.LANDOLL.COM



Copyright 2022. Landoll Company, LLC

“All rights reserved, including the right to reproduce this material or portions thereof in any form.”

