

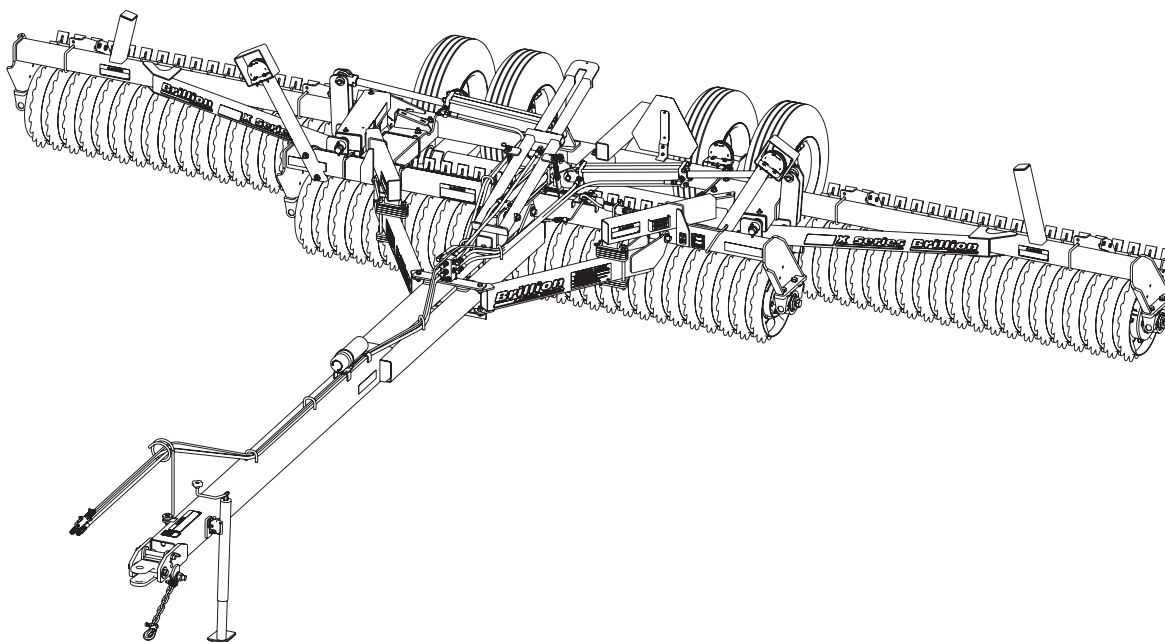

# X Pulverizer Models X20-26 Operator's Manual



**LANDOLL COMPANY, LLC**

1900 North Street

Marysville, Kansas 66508

(785) 562-5381

800-428-5655 ~ [WWW.LANDOLL.COM](http://WWW.LANDOLL.COM)

## Manuals for X20 - X26 Pulverizer (Folding)

Manual Number	Manual Type
F-788	Operator's Manual
F-787	Parts Manual



## **DANGER**

**DO NOT** operate or perform any maintenance tasks on this equipment until you have completed the following:

- 1. Receive proper training to operate this equipment safely.**
- 2. Read and understand the operator's manual.**
- 3. Be thoroughly trained on inspection and repair procedures.**

**Failure to comply with this warning may result in serious injury or possibly death.**



# Table of Contents

---

## 1 Safety

Introduction . . . . .	1-1
Description of Unit . . . . .	1-1
Using this Manual . . . . .	1-1
Owner Assistance . . . . .	1-1
Warranty Registration . . . . .	1-1
Safety . . . . .	1-2
Understanding Safety Statements . . . . .	1-2
Transporting Safety . . . . .	1-2
Safety Instructions for Towing Vehicles . . . . .	1-3
Attaching, Detaching and Storage . . . . .	1-3
Maintenance Safety . . . . .	1-3
Protective Equipment . . . . .	1-3
Prepare for Emergencies . . . . .	1-3
Tire Safety . . . . .	1-3
Chemical Safety . . . . .	1-3
High Pressure Fluid Safety . . . . .	1-4
Safety Chain . . . . .	1-4
Decals . . . . .	1-5

## 2 Assembly

Frame and Transport Axle Assembly . . . . .	2-2
Tire Installation . . . . .	2-2
Transport Lock Installation . . . . .	2-4
Center Roller Assembly Installation . . . . .	2-5
Drawbar and Brace Installation . . . . .	2-8
Drawbar Components . . . . .	2-9
Wing Cylinder Installation . . . . .	2-10
Hydraulic Installation . . . . .	2-11
Plumb the Hydraulic Circuit . . . . .	2-11
Purging the Hydraulic System . . . . .	2-14
Wing to Frame Installation . . . . .	2-15
Transport Lock Linkage Assembly . . . . .	2-16
Wing Roller Assembly . . . . .	2-17
Warning Lamp Installation . . . . .	2-20
Center Notch Wheel Scraper - Optional . . . . .	2-22
Wing Notch Wheel Scraper - Optional . . . . .	2-23
Center V-Wheel Scraper - Optional . . . . .	2-24
Wing V-Wheel Scraper - Optional . . . . .	2-25
Acre Meter - Optional . . . . .	2-26
Weight Kits - Optional . . . . .	2-28

### **3 Operation**

Tractor Preparation . . . . .	3-1
Pulverizer Preparation . . . . .	3-1
Attaching to the Tractor . . . . .	3-2
Hitch Lock . . . . .	3-2
Hydraulic System . . . . .	3-3
General Operation . . . . .	3-3
Operation of Transport Lock . . . . .	3-4
Field to Road . . . . .	3-4
Road to Field . . . . .	3-5
Drawbar Adjustment . . . . .	3-6
Scraper Adjustment . . . . .	3-7
Loup Acre Meter Kit - Optional . . . . .	3-8
Settings for Loup Acre Meters . . . . .	3-8
Field Acres . . . . .	3-8
Total Acres . . . . .	3-8
Pulses Per 400 Feet . . . . .	3-8
Width . . . . .	3-8
Password . . . . .	3-8
Changing the Password . . . . .	3-9
Battery Replacement . . . . .	3-9
Transport . . . . .	3-10

### **4 Maintenance**

General Torque Specifications . . . . .	4-1
Hydraulic Fitting Torque Specifications . . . . .	4-2
Fasteners . . . . .	4-2
Tires . . . . .	4-3
Wheel Hub Bearing Maintenance . . . . .	4-3
Lubrication Maintenance . . . . .	4-3
Hydraulic System Maintenance . . . . .	4-4
Purging Hydraulic System after repairs . . . . .	4-4
Warning Lamps . . . . .	4-5
Roller Bearing Maintenance . . . . .	4-6
Roller Axle Assembly . . . . .	4-7
Clamp Tightening . . . . .	4-7
Clamp End Spacers - Optional . . . . .	4-8
Acre Meter Troubleshooting . . . . .	4-10
Storage . . . . .	4-10

### **5 Specifications**

## Introduction

The implement described in this manual has been designed with care and built by skilled workers using quality materials and processes. Proper assembly and maintenance will provide you with satisfactory use for seasons to come.

DANGER

**Read this entire manual before attempting to assemble, adjust or operate this implement. Failure to comply with this warning can result in personal injury or death, damage to the implement or its components and inferior operation.**

## Description of Unit

Based off of the X-folding concept, the slightly wider center section of the X Series offers a manageable transport width and transport height. The X Series accommodates use as a companion tool with a disc, finisher or field cultivator. The X Series uses a single remote hydraulic system and transport lock. Choice of Notched, Crowfoot, Optimizer or V-Wheel ductile iron wheels allow these machines to be set-up to match your soil conditions.

## Using this Manual

This manual will familiarize you with safety, assembly, operation, adjustment, and maintenance. Read this manual and follow the recommendations to help ensure safe and efficient operation.

- The information in this manual is current at time of printing. Some parts may have changed to assure top performance.
- Location reference: Right and Left designations in this manual are determined by facing the direction the implement will travel during field operation, unless otherwise stated.

## Owner Assistance

If customer service or repairs are needed, contact your Brillion dealer. Implement parts should only be replaced with Brillion parts. Have Serial Number and complete Model Number available when ordering parts from your Brillion dealer. If items covered in this manual are not understood, contact your local Brillion Dealer.

## Warranty Registration

Brillion Farm Equipment, by Landoll, shall have no warranty obligation unless each product is registered, within 10 days of retail purchase, using the Landoll Corporation Ag Products on-line registration process. Please refer to the Ag Products Policy and Procedures Manual, accessible at [www.landoll.com](http://www.landoll.com) for step by step instructions regarding product registration.

Enter your product information below for quick reference.

Refer to the Data Plate as shown. **See Figure 1-1.**

MODEL NUMBER \_\_\_\_\_

SERIAL NUMBER \_\_\_\_\_

DATE OF PURCHASE \_\_\_\_\_

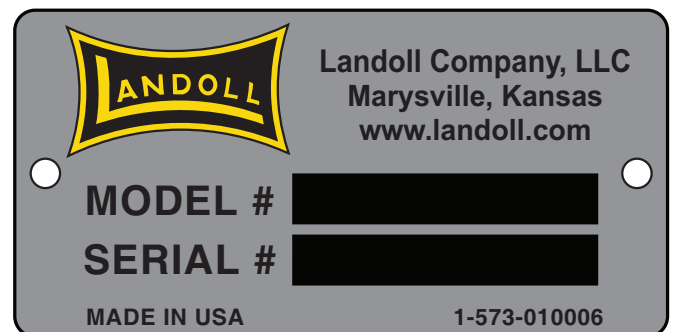

**Figure 1-1: Data Plate**

# Safety

**NOTE**

*Investigation has shown that nearly 1/3 of all farm accidents are caused by careless use of machinery. Insist that all people working with you or for you abide by all safety instructions.*

## Understanding Safety Statements

You will find various types of safety information on the following pages and on the implement decals (signs) attached to the vehicle. This section explains their meaning.

<b>NOTICE</b>
Special notice - read and thoroughly understand.

 <b>CAUTION</b>
Proceed with caution. Failure to heed caution <u>may</u> cause injury to person or damage product.

 <b>WARNING</b>
Proceed with caution. Failure to heed warning <u>will</u> cause injury to person or damage product.

 <b>DANGER</b>
Proceed with extreme caution. Failure to heed notice will cause injury or death to person and/or damage product.

**NOTE**

*You should read and understand the information contained in this manual and on the implement decals before you attempt to operate or maintain this equipment.*

- Examine safety decals and be sure you have the correct safety decals for the implement.
- Order replacement decals through your Brillion dealer.
- Keep these signs clean so they can be observed readily. It is important to keep these decals cleaned more frequently than the implement. Wash with soap and water or a cleaning solution as required.
- Replace decals that become damaged or lost. Also, be sure that any new implement components installed during repair include decals which are assigned to them by the manufacturer.

- When applying decals to the implement, be sure to clean the surface to remove any dirt or residue. Where possible, sign placement should protect the sign from abrasion, damage, or obstruction from mud, dirt, oil etc.

 <b>DANGER</b>
<ul style="list-style-type: none"> <li>• <b>Do not allow anyone to ride on the tractor or implement. Riders could be struck by foreign objects or thrown from the implement.</b></li> <li>• <b>Never allow children to operate equipment.</b></li> <li>• <b>Keep bystanders away from implement during operation.</b></li> </ul>

## Transporting Safety

**IMPORTANT**

**It is the responsibility of the owner/operator to comply with all state and local laws.**

- When transporting the machine on a road or highway, use adequate warning symbols, reflectors, lights and slow moving vehicle sign as required. Slow moving tractors and towed machines can create a hazard when driven on public roads. They are difficult to see, especially at night.
- Do not tow a machine that, when fully loaded, weighs more than 1.5 times the weight of the towing vehicle.
- Carry reflectors or flags to mark the tractor and machine in case of breakdown on the road.
- Do not transport at speeds over 20 MPH under good conditions. Never travel at a speed which does not allow adequate control of steering and stopping. Reduce speed if towed load is not equipped with brakes.
- Avoid sudden stops or turns because the weight of the machine may cause the operator to lose control of the tractor.
- Use caution when towing behind articulated steering tractors; fast or sharp turns may cause the machine to shift sideways.
- Keep clear of overhead power lines and other obstructions when transporting. Know the transport height and width of your machine. **See “Specifications” on page 5-1.**



## Safety Instructions for Towing Vehicles

The maximum travel speed is the lesser of

- The limit of the road conditions;
- The maximum specified ground speed;
  - for towing operations as indicated in this manual or SIS;
  - of the towed vehicle as indicated in its operator's manual, SIS, or information sign;
- The maximum ground speed of the towed equipment combination shall be limited to the lowest specified ground speed of any of the towed machines. This speed is the ground speed limitation.

**EXAMPLE:** If the tractor is capable of 25 mph, the first implement has a SIS for 19 mph, and the last implement's operator's manual states its specified ground speed is 15 mph, the towed equipment combination ground speed limitation is 15 mph.

## Attaching, Detaching and Storage

- Do not stand between the tractor and machine when attaching or detaching machine unless both are not moving.
- Before applying pressure to the hydraulic system, be sure all connections are tight and that hydraulic hoses are not damaged.
- Completely raise machine to engage Transport Lock. If desired to store lowered and on unpaved surface, place hardwood blocks under roller to keep off ground.
- Block implement so it will not roll when unhitched from the tractor.
- Relieve pressure in hydraulic lines before uncoupling hydraulic hoses from tractor.
- Use the Safety Chain to help control drawn machinery should it separate from the tractor drawbar.

### NOTE

*To relieve hydraulic pressure: Depending on tractor hydraulic system, some can be relieved by actuating control lever after engine is stopped. If tractor has electric over hydraulic controls, it may be necessary to move the control lever to the float position. Refer to Tractor's Operator's Manual.*

*Wear protective gloves and safety glasses or goggles when working with hydraulic systems.*

## Maintenance Safety

- Block the machine so it will not roll when working on or under it.
- Make sure Transport Lock is installed and secured.
- Do not make adjustments or lubricate machine while it is in motion.
- Make sure all moving parts have stopped and all system pressure is relieved.
- Understand the procedure before doing the work. Use the proper tools and equipment.

## Protective Equipment

- Wear protective clothing and equipment appropriate for the job. Avoid loose fitting clothing.
- Because prolonged exposure to loud noise can cause hearing impairment or hearing loss, wear suitable hearing protection, such as earmuffs or earplugs.

## Prepare for Emergencies

- Keep a First Aid Kit and Fire Extinguisher handy.
- Keep emergency numbers for doctor, ambulance, hospital and fire department near the phone.

## Tire Safety

Tire changing can be dangerous and should be performed by trained personnel using correct tools and equipment.

- When inflating tires, use a clip-on chuck and extension hose long enough to allow you to stand to one side, not in front of or over the tire assembly. Use a safety cage if available.
- When removing and installing wheels use wheel-handling equipment adequate for the weight involved.

## Chemical Safety

Agricultural chemicals can be dangerous. Improper use can seriously injure persons, animals, plants, soil and property.

- Read chemical manufacturer's instructions and store or dispose of unused chemicals as specified. Handle chemicals with care and avoid inhaling smoke from any type of chemical fire.
- Store or dispose of unused chemicals as specified by the chemical manufacturer.

**SAFETY**

## High Pressure Fluid Safety

Escaping fluid under pressure can be nearly invisible and have enough force to penetrate the skin causing serious injury. Use a piece of cardboard, rather than hands, to search for suspected leaks.

- Any fluid injected into the skin must be surgically removed within a few hours or gangrene may result.
- Avoid the hazard by relieving pressure before disconnecting hydraulic lines.

**NOTE**

*To relieve hydraulic pressure: Depending on tractor hydraulic system, some can be relieved by actuating control lever after engine is stopped. If tractor has electric over hydraulic controls, it may be necessary to move the control lever to the float position. Refer to Tractor's Operator's Manual.*

*Wear protective gloves and safety glasses or goggles when working with hydraulic systems.*

## Safety Chain

1. Use a Safety Chain to help control drawn machinery should it separate from the Tractor Drawbar.
2. Use a chain with a strength rating equal to or greater than the gross weight of towed machinery, in accordance with ASAE S338.2 specifications. If two or more machines are pulled in tandem, a larger chain may be required. Chain capacity must be greater than the total weight of all towed implements.

A second chain should be used between each implement.

3. Attach the chain to the Tractor Drawbar Support or specified anchor location. Never attach the chain to an intermediate support. Allow only enough slack in the chain to permit turning. The distance from Hitch Pin to attachment point or intermediate support point should not exceed 9 inches. **See Figures 1-2 and 1-3.** If the distance from the Drawbar Pin to either the front or rear chain attachment point exceeds 9 inches, intermediate chain support is required. **See Tractor Operator's Manual.**

4. Replace chain if any links or end fittings are broken, stretched or damaged.
5. Do not use a Safety Chain for towing.

**See page 3-2 for Hitch Lock functionality.**

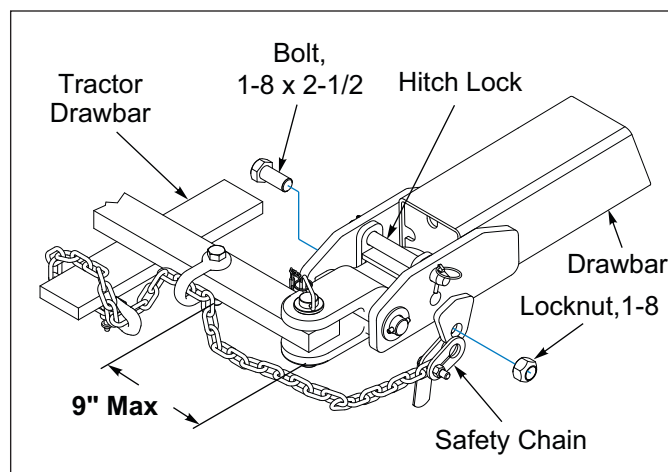

**Figure 1-2: Drawbar without Hammer Strap**

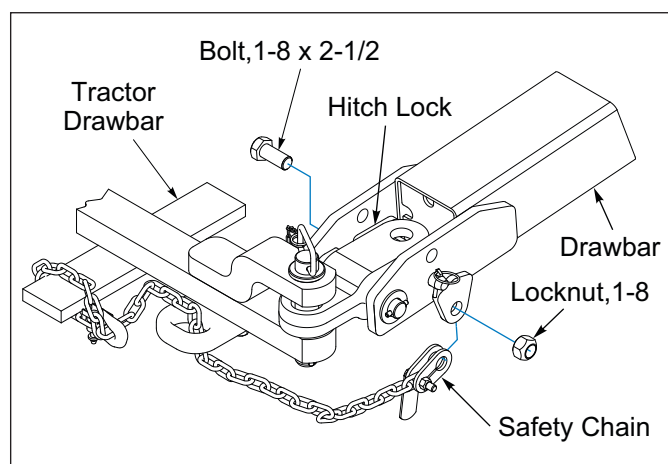

**Figure 1-3: Drawbar with Hammer Strap**

Decals



ITEM 1 - 3J678



ITEM 2 - 5J859



ITEM 3  
528933



ITEM 4  
528934



ITEM 5  
528938

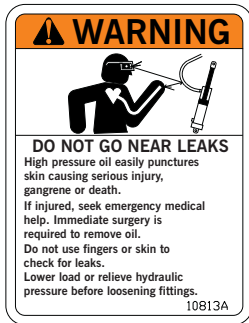

ITEM 6  
3K706

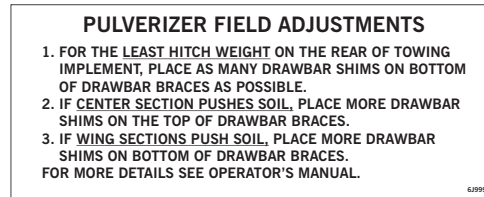

ITEM 7  
6J999



ITEM 8 - 3J675



ITEM 11  
170510



ITEM 15 - 232188



ITEM 9  
2-573-010198



ITEM 12  
193501



ITEM 16  
144193



ITEM 13  
193664



ITEM 10  
2P151



ITEM 14  
193500



ITEM 17 - 1-573-010006

Figure 1-4: Decals

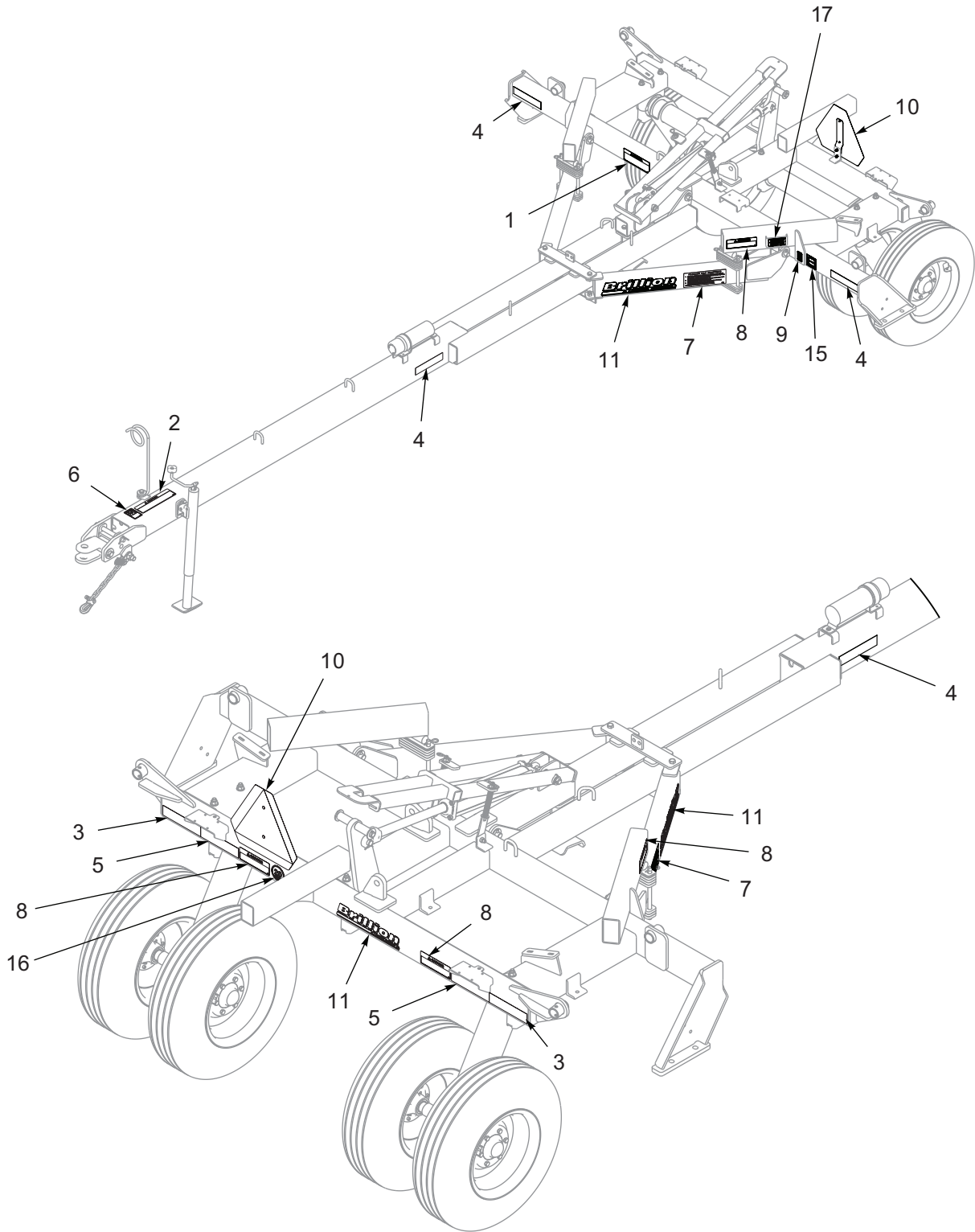

Figure 1-5: Decal Locations, Center (1 of 4)

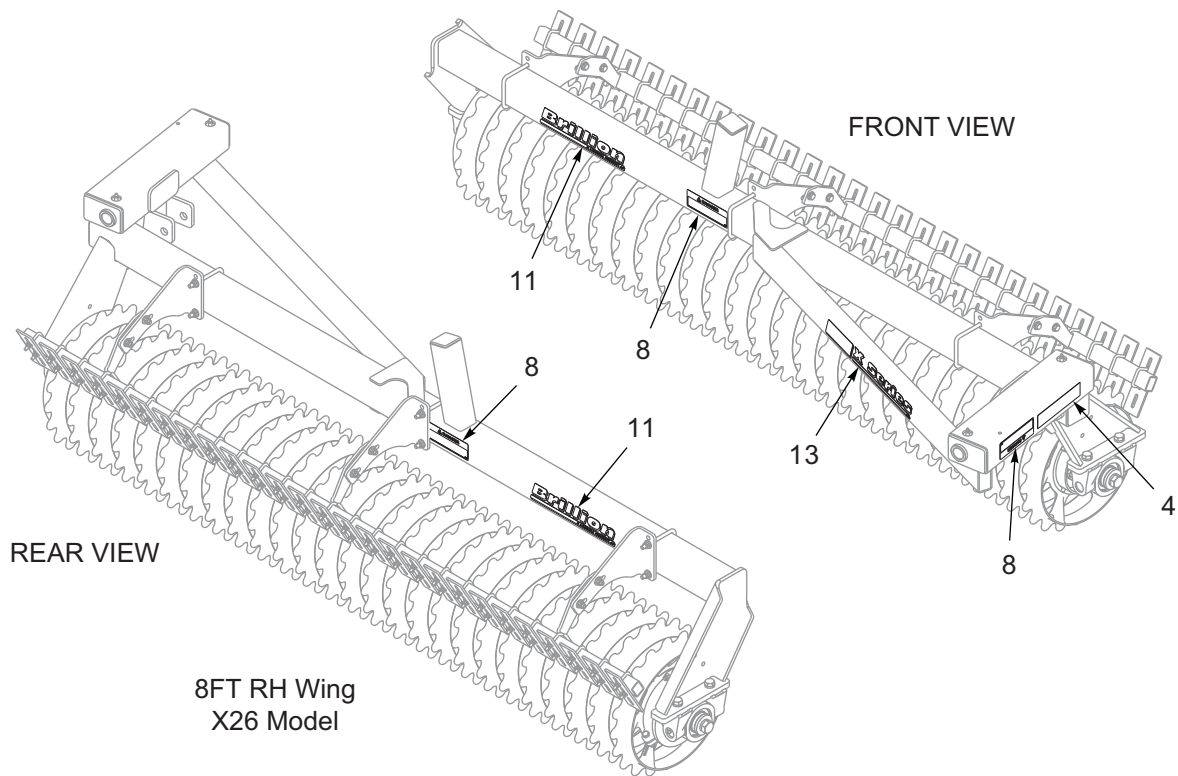
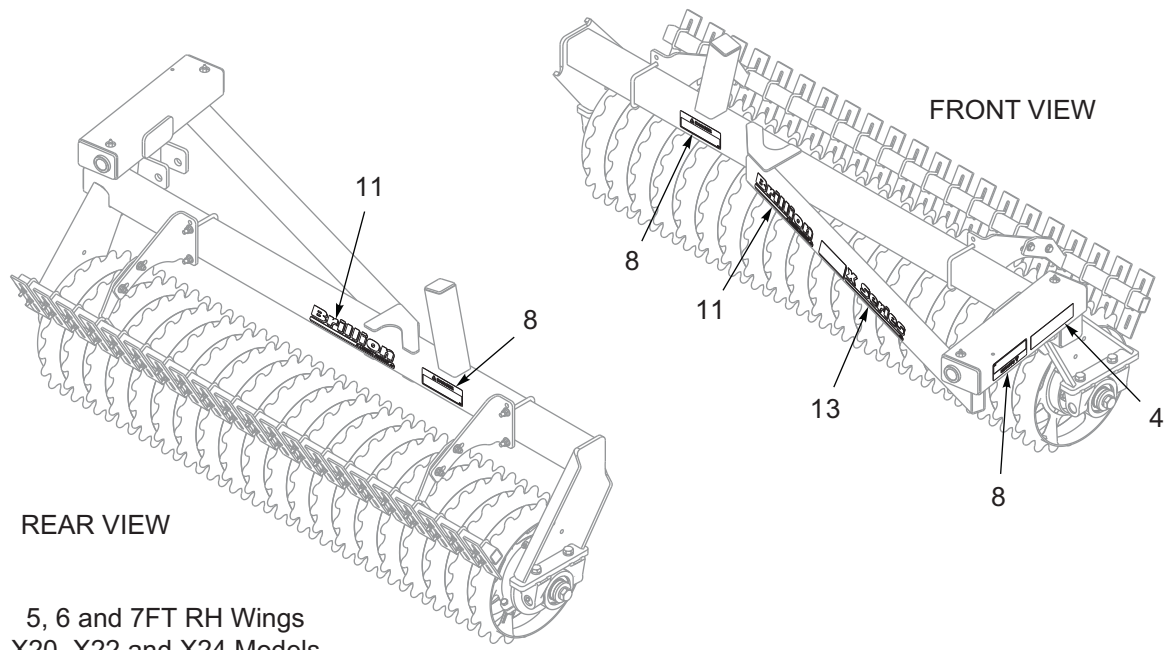

Figure 1-6: Decal Locations, Right Hand Wing (2 of 4)

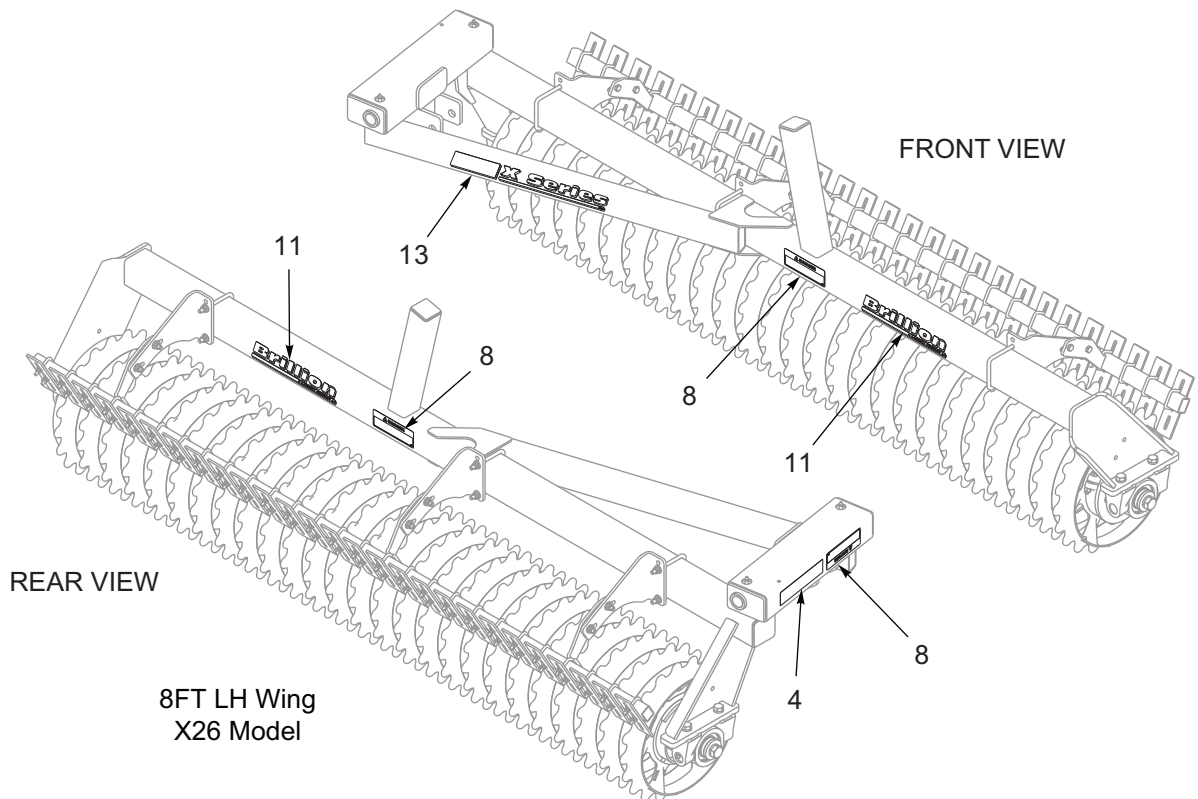
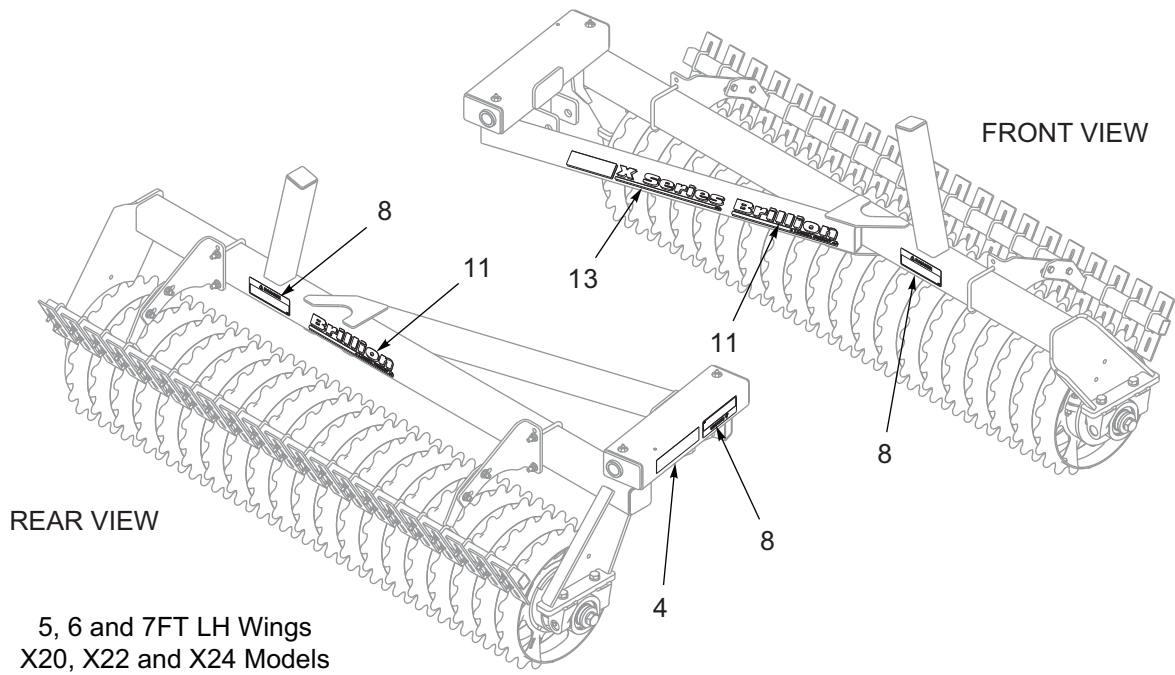

Figure 1-7: Decal Locations, Left Hand Wing (3 of 4)

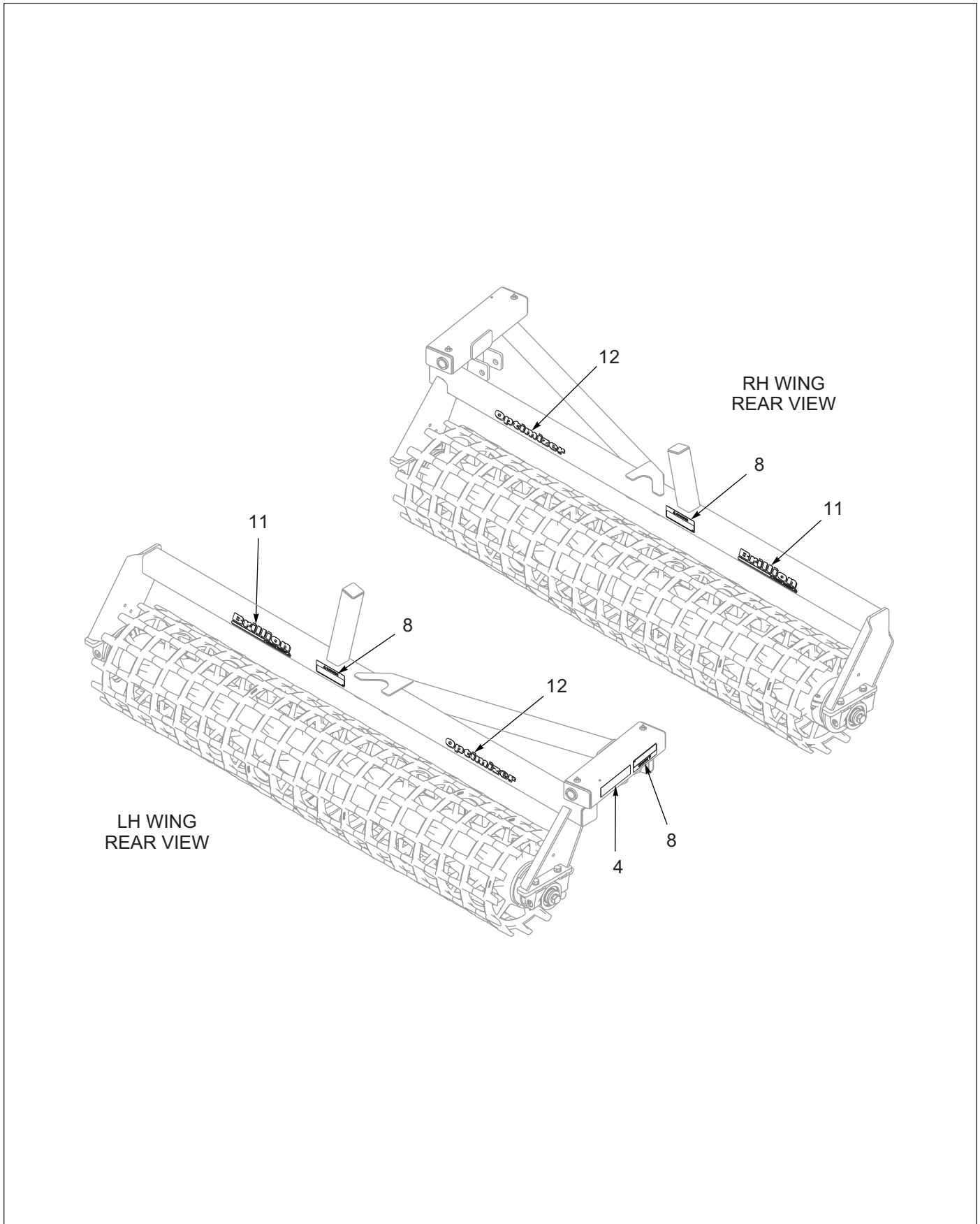

Figure 1-8: Decal Locations, Optimizer Wings (4 of 4)





## Assembly

**CAUTION**

Do Not work on or under this machine unless securely blocked and supported by a hoist or tractor or by other sufficient means!

**WARNING**

Do not attempt to lift heavy parts manually. Use a hoist or a forklift to move these parts into position.

**NOTE**

Refer to the repair Parts Manual F-787 for identification of parts and for approximate relationship of the parts in assembly. Your exact model may vary slightly from the illustrations.

To ensure alignment of assemblies, leave the nuts loose until completion of final assembly. Use lock washers or flat washer as specified. Spread all cotter pins.

After completion of final assembly, tighten all nuts evenly to prevent misalignment, distortion or binding. Tighten all screws and nuts to the recommended torques.

**IMPORTANT**

- **If pre-assembled parts or fasteners are temporarily removed, remember where they go. It is best to keep parts separated.**
- **Check that all working parts move freely, bolts are tight and cotter pins spread.**
- **Refer to the Torque Table for proper torque valves. Note the different torque requirements for bolts with locknuts.**

"Left" and "Right" refer to directions seen as if standing behind the machine and facing in the direction of forward travel.

**IMPORTANT**

All Harnesses must be firmly attached to machine frame members or Hydraulic Hoses so they do not sag or become torn loose by field debris. Use the tie wraps provided.

Check to be sure the Harnesses are slack enough so as to not be stretched or interfered with while raising and lowering of the machine.

## Frame and Transport Axle Assembly

Position the Transport Axle on a level surface under the designated frame assembly area. **See Figure 2-2.**

Using blocks or other supports, block up the Frame approximately 17". Be sure that it is secure and cannot topple. The Transport Axle should be positioned approximately middle of the Frame.

### **NOTE**

*The Plastic Bearing Inserts are maintenance free and require no grease.*

1. Place two Bearing Inserts into two Bearing Halves.
2. Position one set under and one on top of the transport axle pipe near the center of the Transport Axle Arm. Slide two 5/8-11 x 11 Bolts up into both halves and into the frame holes. Attach with Flat Washers and Locknuts. Repeat for the left and right hand side. Tighten all hardware.
3. Attach the SMV sign to the rear of the frame using two 5/16-18 x 1 Bolts, Flat Washer and Locknuts.

## Tire Installation



### **WARNING**

**Use a torque wrench to assure proper torque. Insufficient torque can cause stud breakage and damage the wheel pilots. Over torque can over stress the studs and strip the threads.**

### **NOTE**

*All tire/wheel assemblies are mounted with the valve stem facing outward from Hub and Spindle.*

### **NOTE**

*Block tire/wheel assemblies securely so they will not roll while working on or under it.*

### **IMPORTANT**

**Torque will drop after the first 10 hours of operation. Check the wheel bolts for proper torque after this interval and retighten them.**

- The Pulverizer uses 9.5L x 15-8 Ply Tires and should be inflated to 44 PSI.
- Install a Tire and Wheel Assembly onto each Transport Axle Hub, with 1/2-20 x 1 Wheel Bolts and tighten to 50 Ft-Lbs using the sequence in **Figure 2-1**. Then tighten to full torque to 85-90 Ft-Lbs.
- Leave supports under frame to support the machine in case of weight shift while adding components.

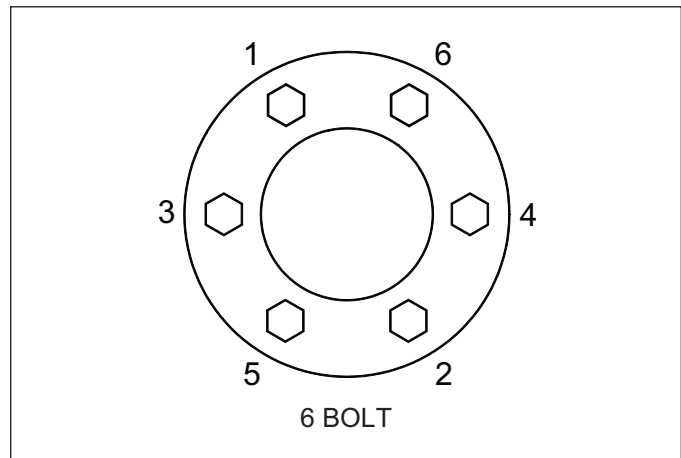

**Figure 2-1: Tightening Sequence**

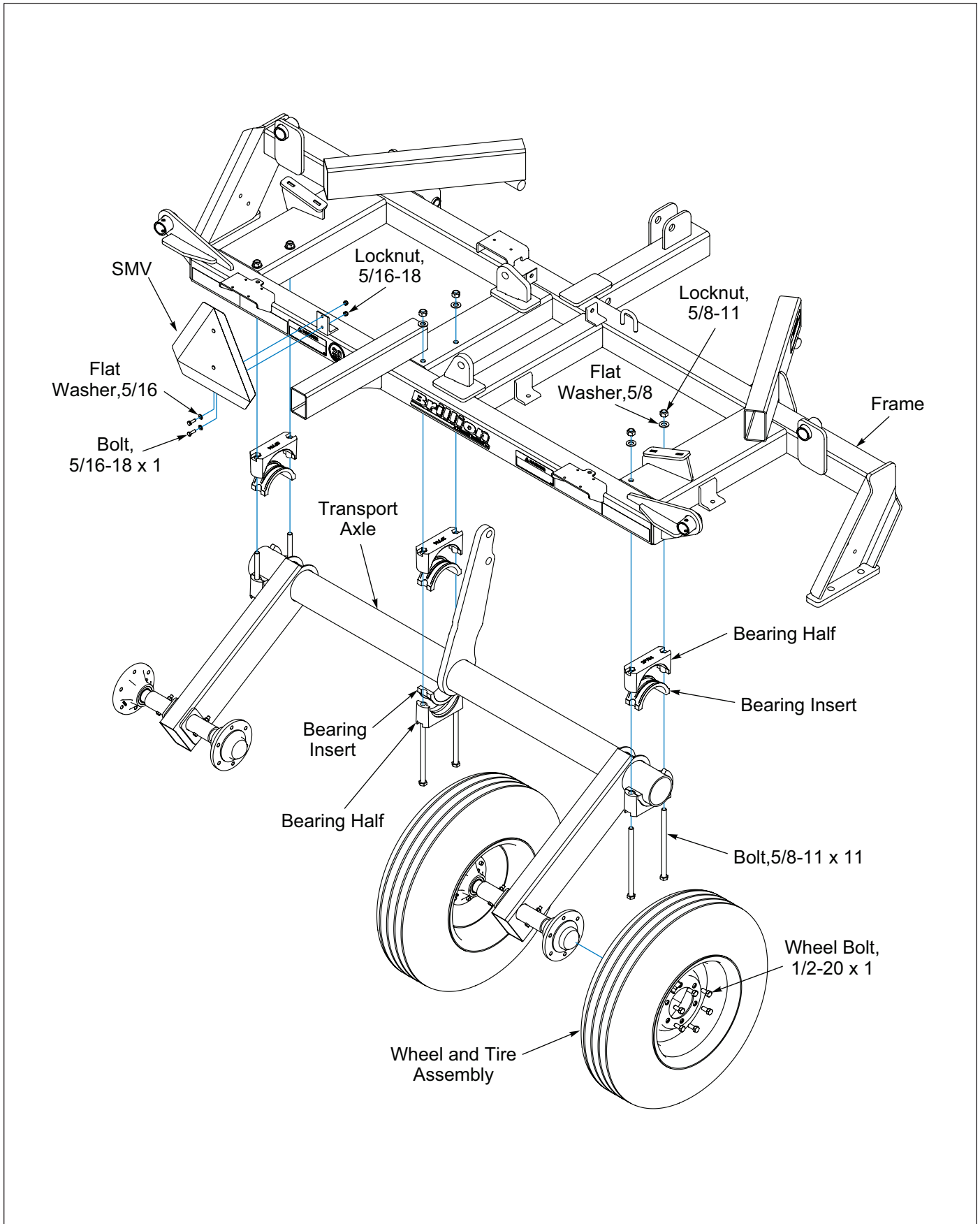
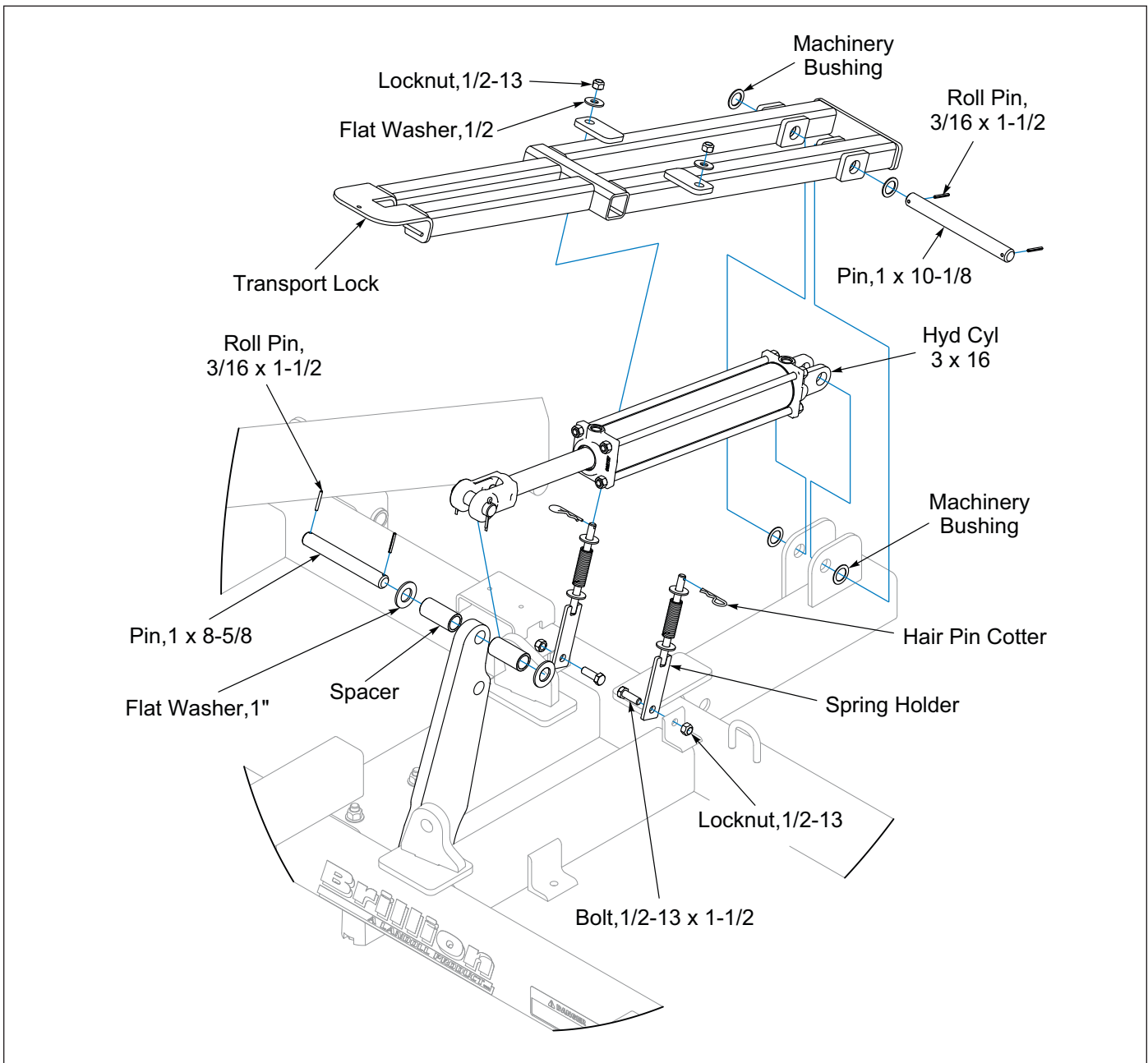

Figure 2-2: Frame and Transport Axle

# Transport Lock Installation

1. Attach the Spring Holders to the frame angles with 1/2-13 x 1-1/2 Bolts and Locknuts. Place a 1/2 Flat Washer, Compression Spring, another 1/2 Flat Washer onto the Spring Holder. **See Figure 2-3.**
2. Position the base end of the 3 x 16 Hydraulic Cylinder port side up between the frame lugs. Lower the Transport Lock over the frame lugs. *The Transport Lock must be centered over the hydraulic cylinder.* Place a machinery bushing on the inside and outside of the Transport Lock and slide 1 x 10-1/8 Pin through all. Secure with 3/16 x 1-1/2 Roll Pin.
3. Attach the rod end of the 3 x 16 Hydraulic Cylinder to the bottom hole of the Transport Axle Arm with vendor supplied hardware.
4. Slide 1 x 8-5/8 Pin into the top hole of the Transport Axle Arm. Place a Sleeve over each end, then a 1 inch Flat Washer. Secure with 3/16 x 1-1/2 Roll Pins.
5. Push down on the Transport Lock and align the Spring Holders with the tabs on the side of the transport lock. Place a 1/2 Flat Washer and Locknut onto the Spring Holder and tighten until the top hole on the Spring Holder is visible. Insert Hairpin Cotter. *The Transport Lock is now in the unlocked position.*



**Figure 2-3: Transport Lock**

## Center Roller Assembly Installation

1. Roller Assemblies are pre-assembled from the factory with stub shafts, bearings, shims, and retaining washers. **NOTE:** *Crowfoot Wheel Rotation Arrow must follow the direction of travel.* See **Figure 2-4.**
2. Loosen the 1-8 Bolt on each end of the Roller Assembly approximately 4 turns.
3. With the Bearing Grease Fitting facing towards the rear of the machine, slide the Trunnion Bearing Mounts onto the Trunnion Bearings and lift the Roller Assembly up to the Center Frame. Hand tighten 3/4-10 hardware to hold Trunnion Bearing Mounts in place.
4. Look at each Trunnion Bearing Mount to make sure that it is sitting perpendicular to the Center Frame Bearing Hanger. If not adjust the Shim Washers accordingly, for each side there are two 11ga and one 14ga Shim Washers. Shim Washers can be all three on the inside between the Stub Shaft shoulder and the Trunnion Bearing, all three can be on the outside between the Trunnion Bearing and Flat Top Washer, or a combination on either side, but all three must be used to minimize the gap. If gap cannot be properly minimized with bearing snap rings to outside, turn bearing around to have snap ring to inside. The bearing inner race is offset with respect to the trunnion bosses by 1/32". By installing bearings with snap rings in versus out, 1/16" difference can be made up at assembly if needed. See **Figure 2-6.**
5. Tighten 3/4-10 and 1-8 hardware to specification per torque chart. See **"General Torque Specifications"** on page 4-1.

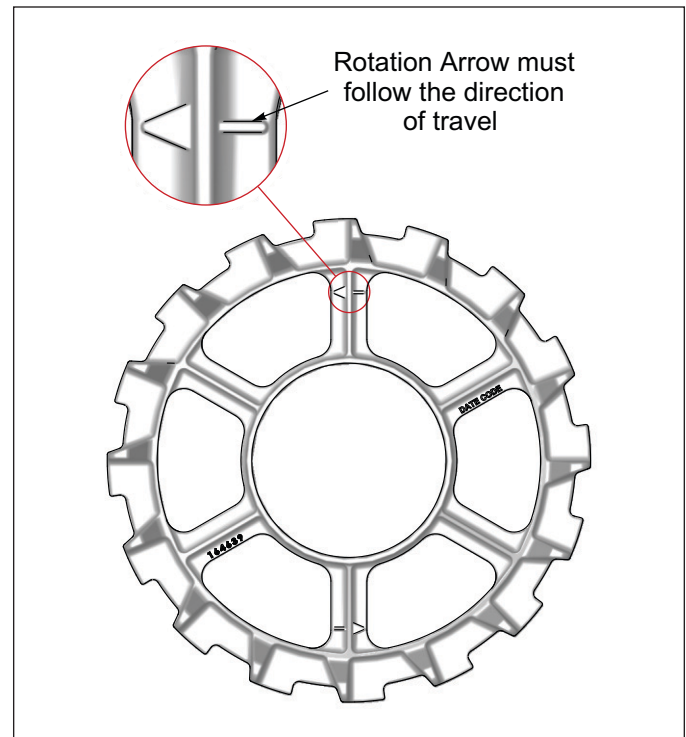

**Figure 2-4: Crowfoot Wheel Rotation Arrow**

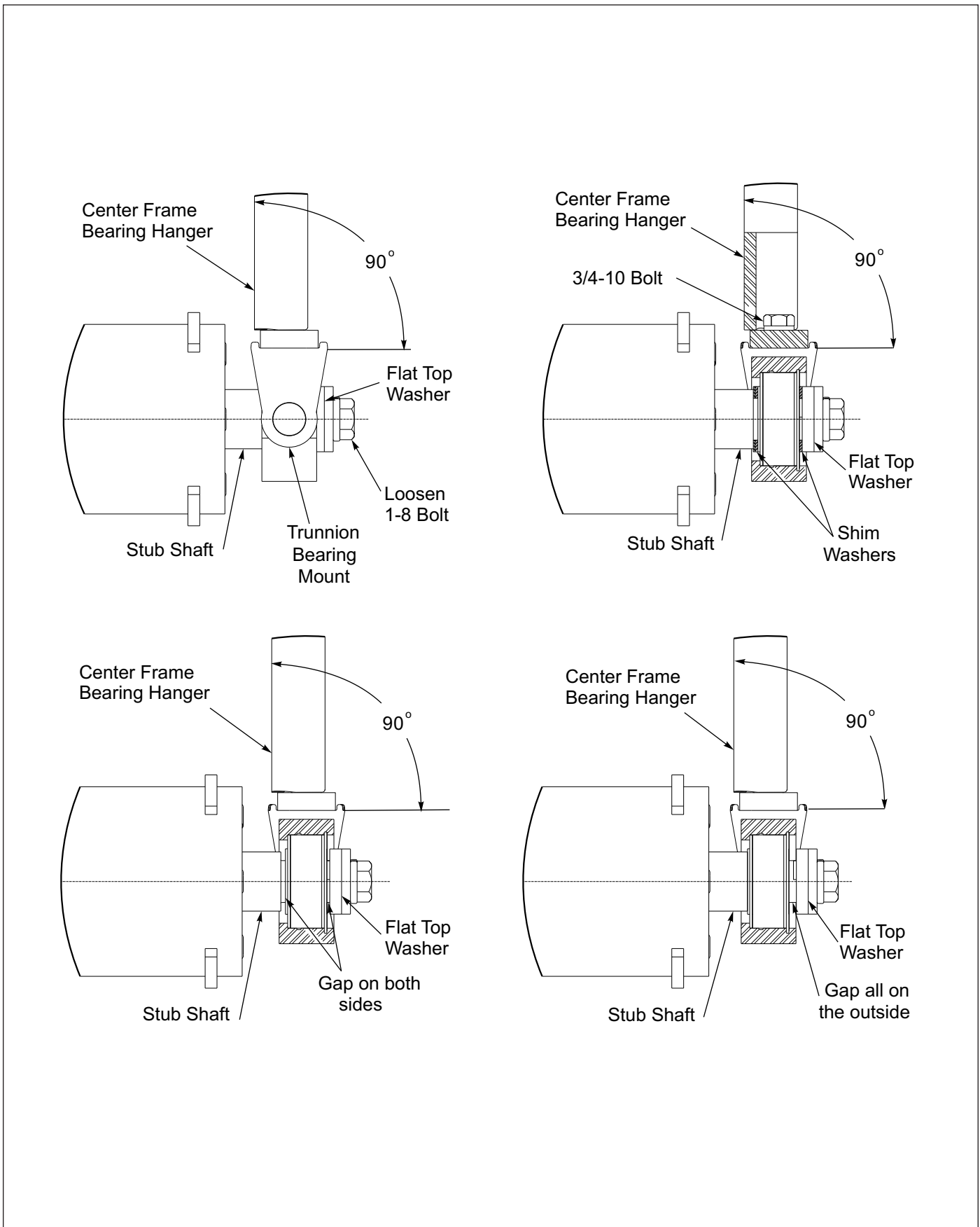

Figure 2-5: Trunnion Spacers

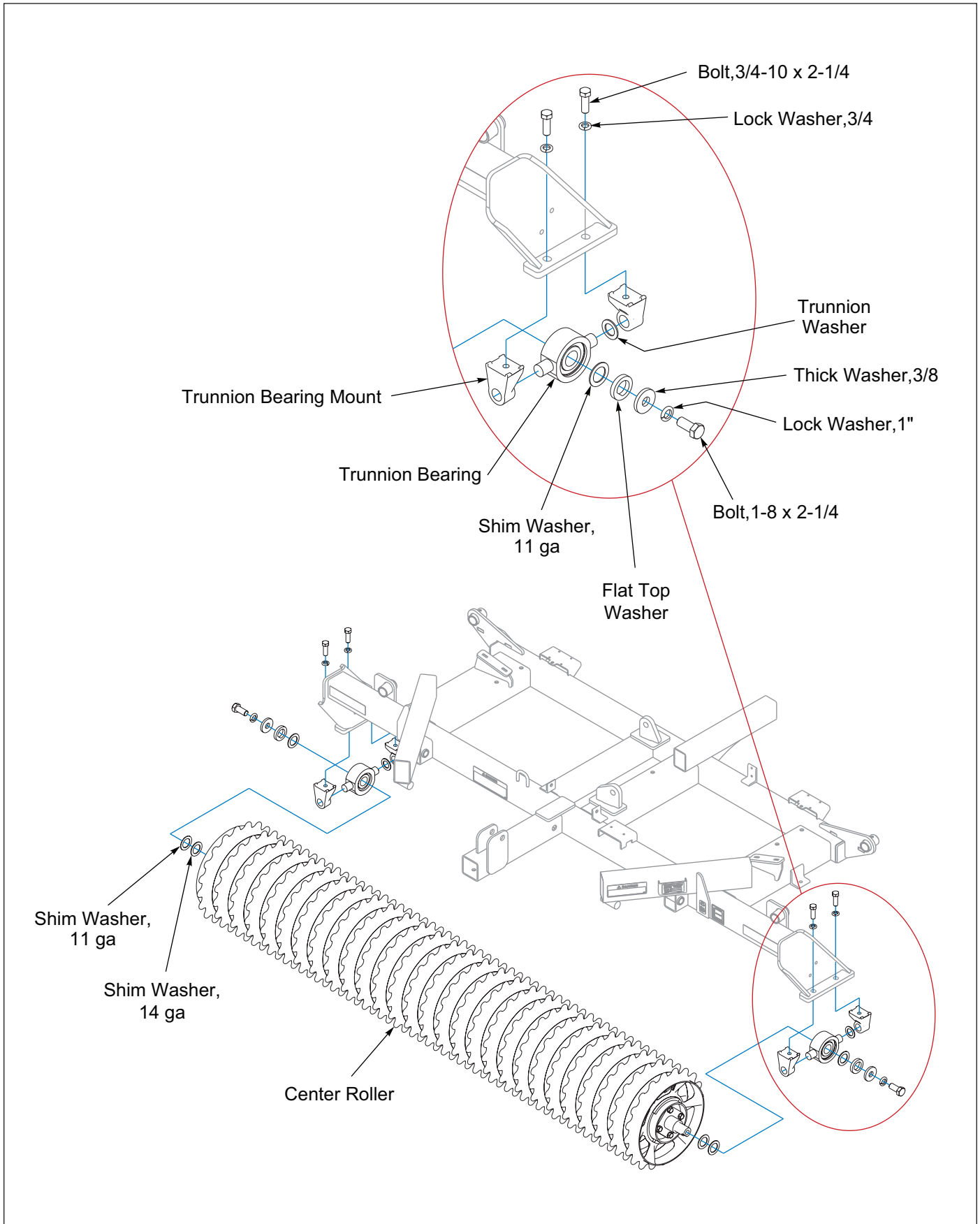

Figure 2-6: Center Roller Assembly Installation

# Drawbar and Brace Installation

1. Attach the Drawbar to the Frame by inserting 1 x 7 Pin through the Drawbar Lugs and the Frame Mounting Tubes. Place a 1 inch Flat Washer on each side and secure with 5/16 x 2 Roll Pin. The Drawbar Braces are left and right. Set the end of the brace with straight straps between the straps on the Drawbar. Attach the end of the brace with bent plates to the Center Frame using 1 x 6-3/4 Pin with a Flat Washer on each end and 5/16 x 2 Roll Pins. See Figure 2-7.

2. Secure the drawbar end with 5/8-11 x 1-3/4 Bolts and Locknuts. Do not tighten these Bolts until both Drawbar Braces are assembled. Use the same procedure to assemble the Drawbar Brace on the opposite side.

3. For the initial settings of the Drawbar, set one 1/8, one 1/4 and three 1/2 Drawbar Shims on top of the strap that is welded on the Drawbar Brace. Insert 5/8 x 10-5/8 Pins through the Shims and the remaining three 1/2 Shims on the bottom of the Drawbar Brace. Secure with Hairpin Cotter at the top and 3/16 x 1-1/8 Roll Pins on the bottom.

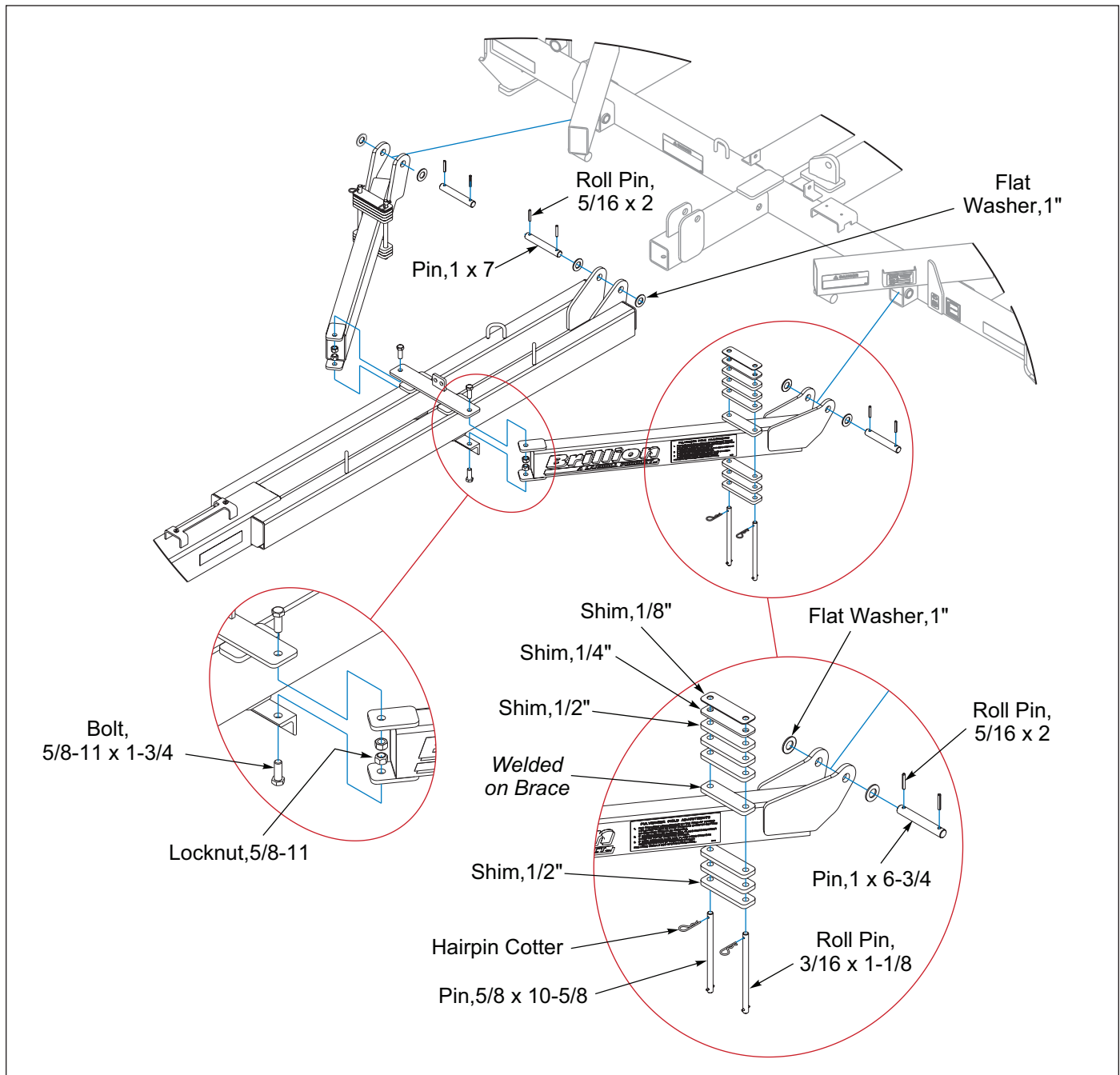
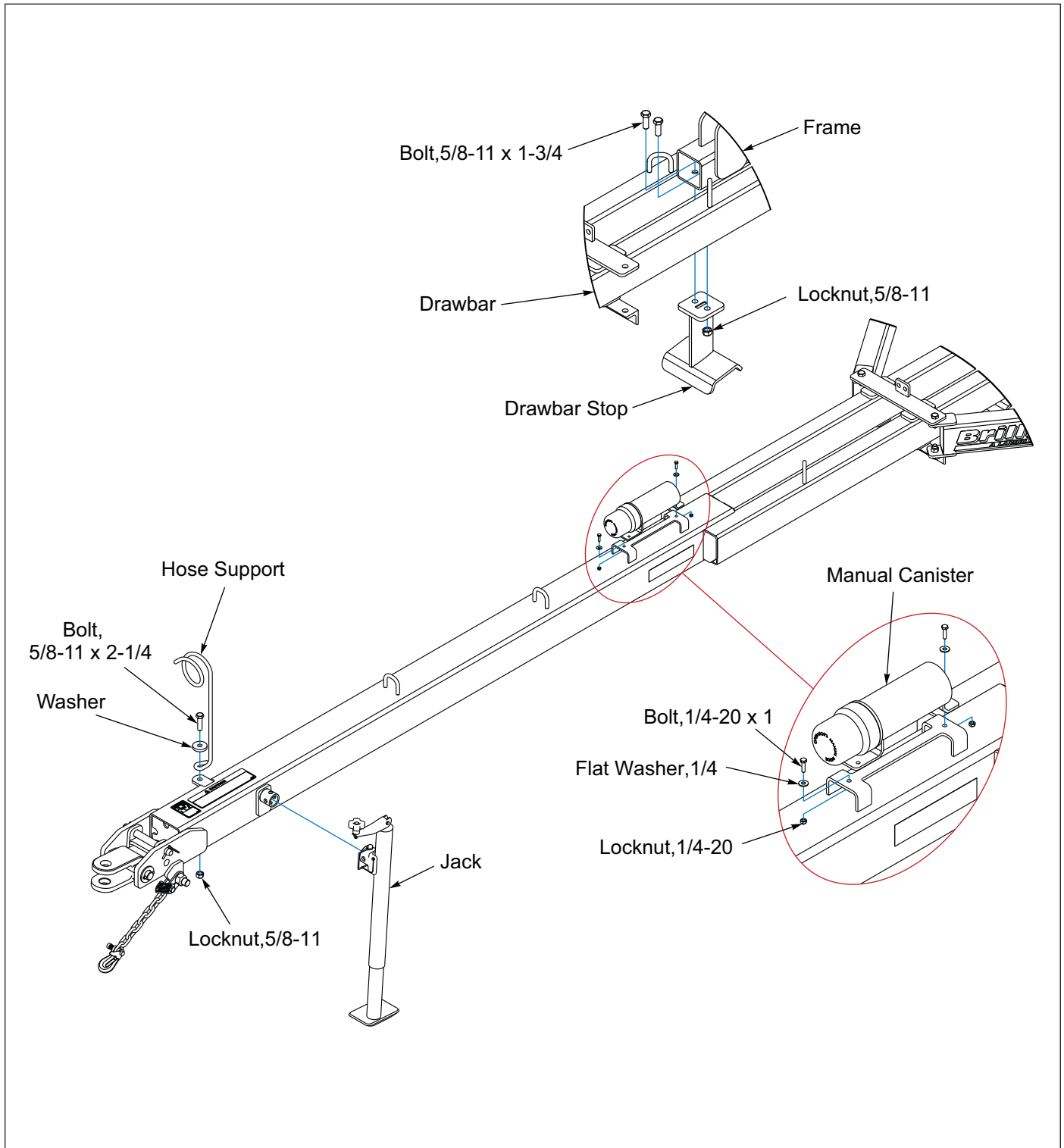

Figure 2-7: Drawbar and Brace Installation



# Drawbar Components

1. Attach the Manual Canister on the top of the Drawbar Bracket with 1/4-20 x 1 Bolts, Flat Washers, and Locknuts. **See Figure 2-8.**
2. Attach the Jack onto the drawbar swivel and secure with vendor supplied 9/16 Jack Pin with Chain.
3. Attach Drawbar Stop to the frame tube with 5/8-11 x 1-3/4 Bolts and Locknuts. *The Drawbar Stop limits the drawbar vertical travel.*
4. Attach the Hose Support to the drawbar lug with 5/8-11 x 2-1/4 Bolt, Washer, and Locknut.



**Figure 2-8: Drawbar Components**

# Wing Cylinder Installation

1. Install the 3-1/2 x 20 Wing Fold Hydraulic Cylinders base end to the center frame lugs with ports facing the front of machine using the vendor supplied hardware. **See Figure 2-9.**

On the Right Hand Cylinder do not spread the Cotter Pins at this time. **See Figure 2-15.** *The Transport Lock Linkage Strap will be assembled on the Cylinder Pin.*

2. Block each Cylinder Rod End Clevis up from the frame to allow for rod movement when purging the hydraulic circuit. **See "Purging the Hydraulic System" on page 2-14.**

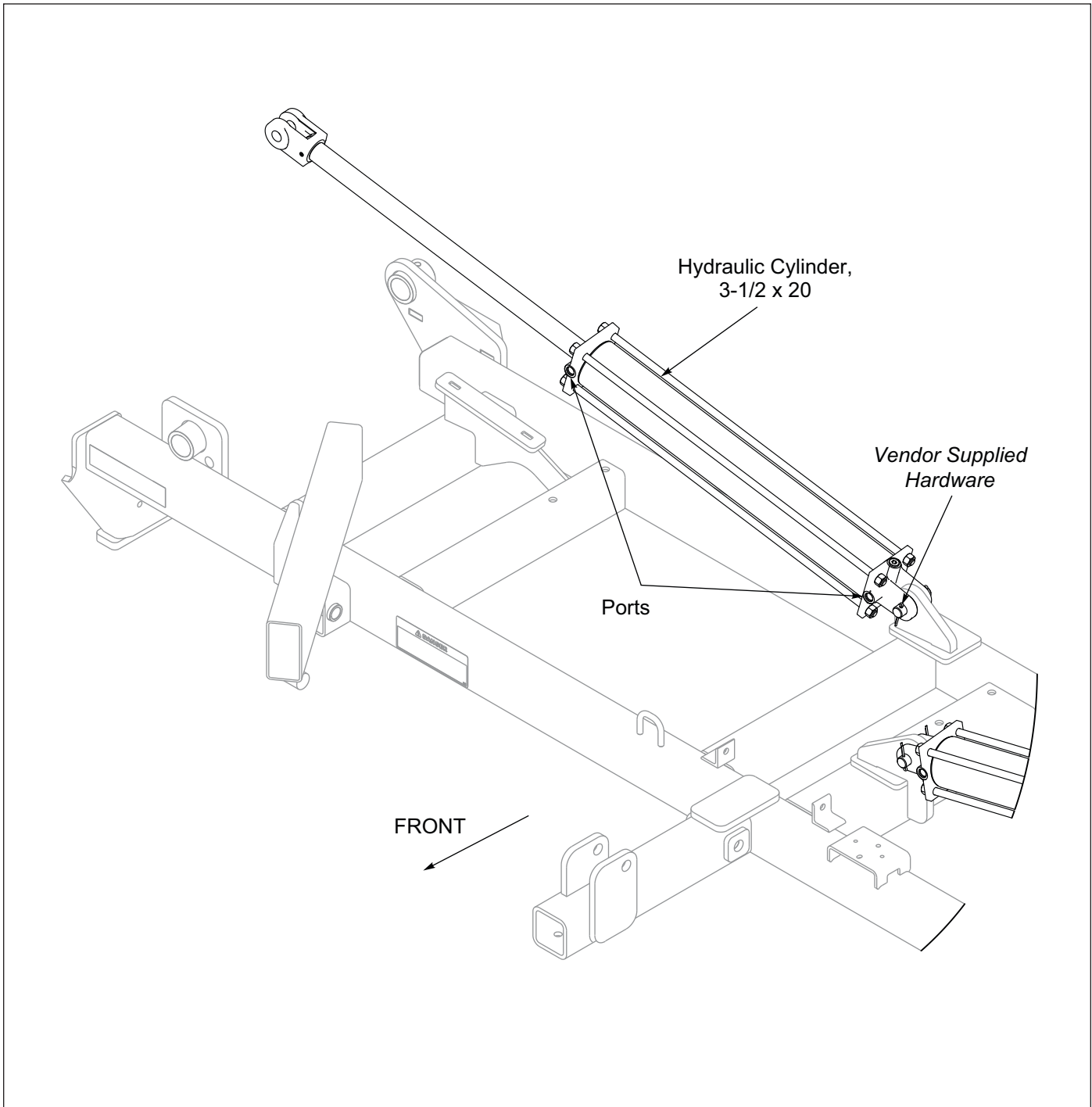

**Figure 2-9: Wing Cylinder Installation**

## Hydraulic Installation

### IMPORTANT

Unfold and lower the unit to the ground and relieve system pressure before attempting to repair, adjust, or disconnect components.



### WARNING

Escaping fluid under pressure can be nearly invisible and have enough force to penetrate the skin causing serious injury. Relieve system pressure before repairing, adjusting, or disconnecting. Use a piece of cardboard, rather than your hands, to search for suspected leaks. See Figure 2-10. Wear protective gloves & safety glasses or goggles when working with hydraulic systems. Keep all components (cylinders, hoses, fittings, etc.) in good repair.

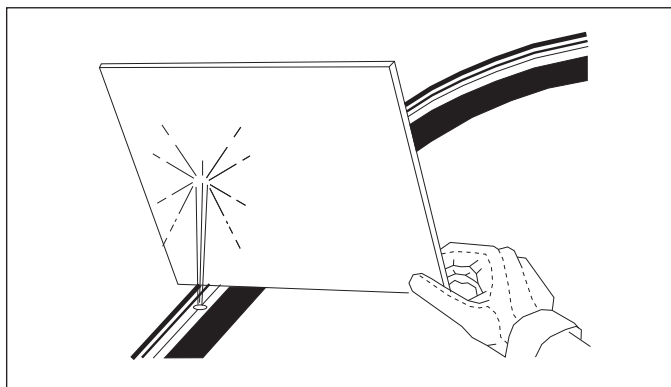

**Figure 2-10: Hydraulic Leak Detection**

The Pulverizer is equipped with a single hydraulic circuit that folds/unfolds the wings and raises/lowers the machine.

**Hydraulic Circuit approximate oil requirement:  
2 gallons**

#### Tightening Procedure For JIC 37° Swivel Female Nuts

1. Check flare and seat for defects.
2. Lubricate the connection.
3. Install hoses without twists.
4. Hand tighten until connection bottoms.
5. Using 2 wrenches to prevent twisting, rotate the swivel nut 2 wrench flats (1/3 turn).
6. For reassembly, follow the same procedure but tighten only 1 wrench flat (1/6 turn).

#### Tightening Procedure For Swivel O-Ring Fittings

1. Lubricate O-Ring and install the fitting until the metal washer which backs up the O-Ring contacts the face of the boss.

2. Orient the fitting by turning counterclockwise up to 1 turn.

Tighten the Locknut using 50-60 Ft-Lbs torque. See “Hydraulic Fitting Torque Specifications” on page 4-2.

## Plumb the Hydraulic Circuit



### CAUTION

Restrictors are installed in the wing fold cylinders to prevent uncontrolled dropping of wings. Removal of these restrictors, or improper installation can result in serious damage to the implement.

#### Manifold Installation

1. Attach the 8-Port Manifold to the front of the Manifold Bracket located on top of the drawbar strap with 1/2-13 x 3-3/4 Bolts, Flat Washers and Locknuts. Install the fittings into the Manifold with the elbow fittings pointing rearward. See Figures 2-11 and 2-12.

#### Hose Installation

1. Install straight restrictors into the Wing Fold Cylinders Base End and Rod End Ports.
2. On the right side Wing Fold Cylinder only, install a 45 degree elbow fitting onto the base end restrictor.
3. Install 90 degree elbow fittings on the restrictor in the Wing Fold Cylinder Rod End Port.
4. Install 90 degree O-Ring fittings into the Lift Cylinder Ports.
5. Attach hoses to the Fold Cylinders. Route the hoses through the drawbar loops to the Manifold. Left Hand Cylinder Hoses go to the left side of Manifold, Right Hand Cylinder Hoses go to the right side.
6. Attach hoses from the Lift Cylinder to the rear of the Manifold. See Figure 2-11.
7. Route the hoses from the front of the Manifold under the manual bracket through the drawbar loops and Hose Holder Support to the front of the Drawbar. Install couplers and fittings into the end of the hoses.
8. Secure all hoses with Tie Wraps.

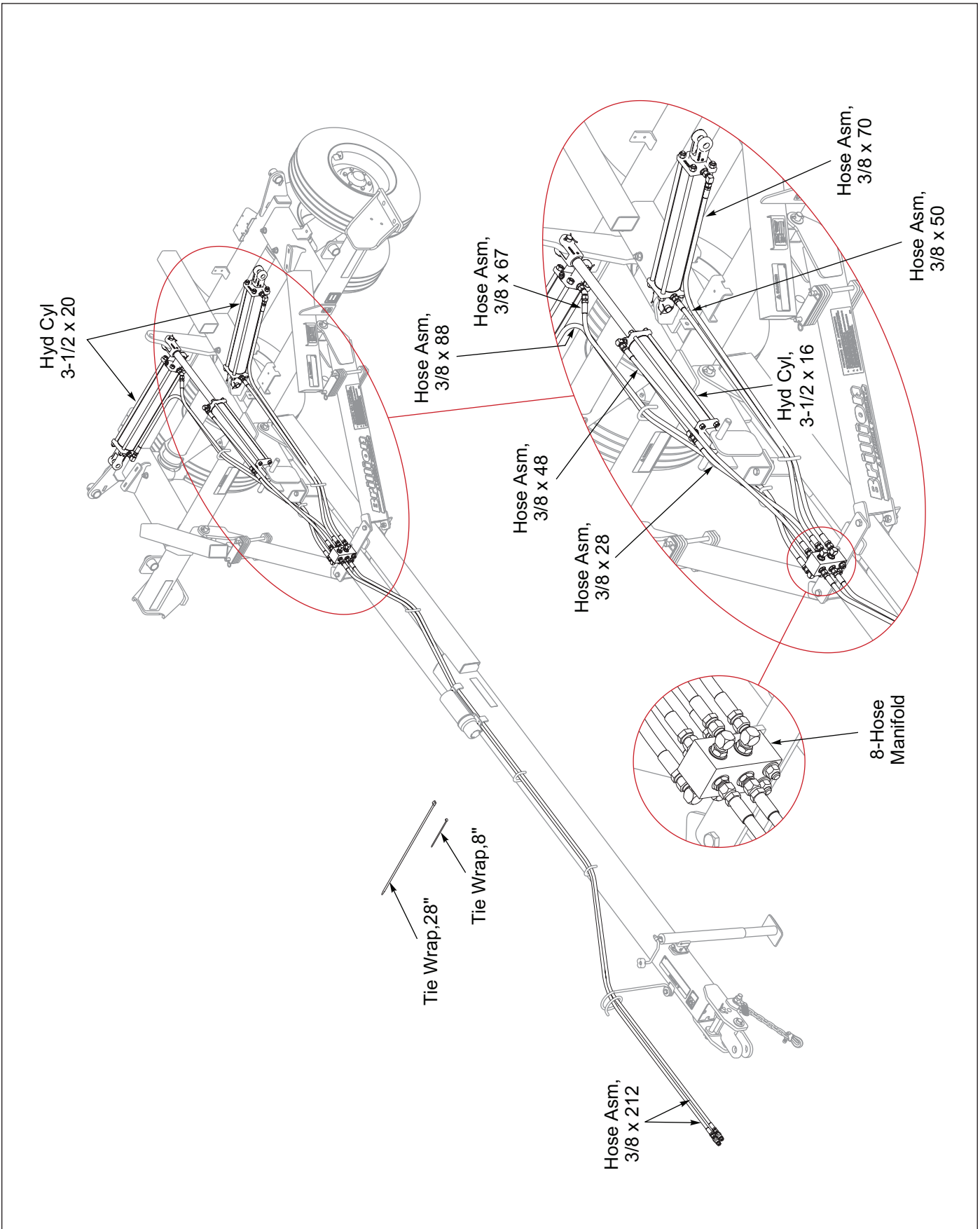

Figure 2-11: Hydraulic Layout

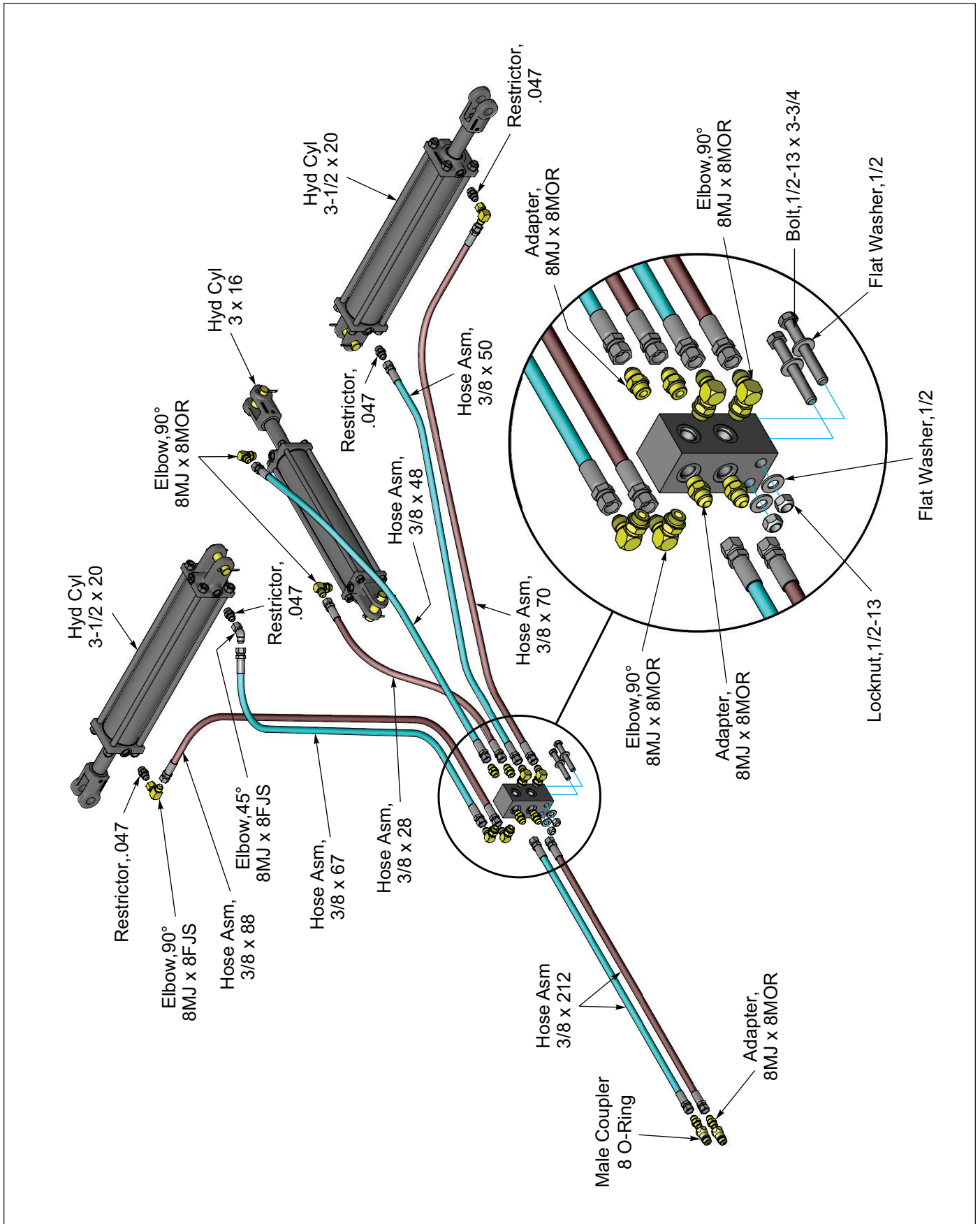

Figure 2-12: Hydraulic Schematic

## Purging the Hydraulic System

### IMPORTANT

Unfold and lower the unit to the ground and relieve system pressure before attempting to repair, adjust, or disconnect components.

### NOTE

*Never unfold the wings past center until all air is out of the hydraulic system, as free-falling may occur.*



### CAUTION

The wings depend upon the passage of oil through a flow restrictor to keep from free falling. If the cylinder is not full of oil the wing will drop and may cause damage to the machine.



### WARNING

Escaping fluid under pressure can be nearly invisible and have enough force to penetrate the skin causing serious injury. Relieve system pressure before repairing, adjusting, or disconnecting. Use a piece of cardboard, rather than your hands, to search for suspected leaks. See Figure 2-13. Wear protective gloves & safety glasses or goggles when working with hydraulic systems. Keep all components (cylinders, hoses, fittings, etc.) in good repair.

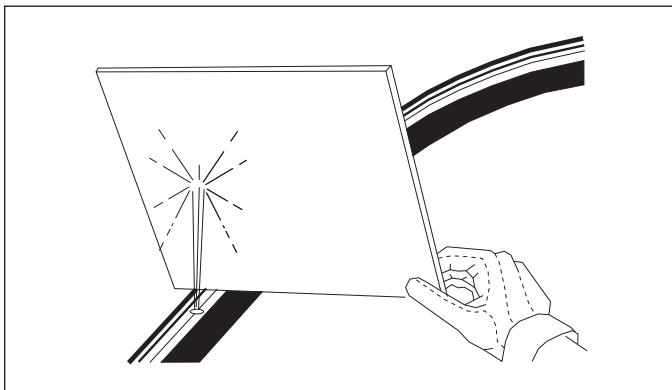

**Figure 2-13: Hydraulic Leak Detection**



### DANGER

Falling wings can cause injury or death. Stand clear when wings are being raised or lowered.



### DANGER

Bleed the air from Wing Lift Cylinders before operating. Failure to do so will allow wings to free-fall and may cause serious personal injury. See Operator's Manual for correct procedure.

The hydraulic system is not filled with oil and should be purged of air before transporting and field operations.

1. Hitch the Tractor to the Pulverizer Drawbar and connect the hydraulic hoses.
2. Check to make sure the tractor hydraulic reservoir is full of the manufacturer's recommended oil.
3. Transport Lock must be disengaged to allow the Lift Cylinder to extend and retract.
4. With the wings unfolded and each Wing Fold Cylinders Rod End Clevis unpinned, block each Fold Cylinder Rod End Clevis up to allow for rod movement. Slowly raise the machine and continue to hold the hydraulic lever until Lift Cylinder is extended and the Fold Cylinders are retracted. Completely extend and retract the Fold and Lift Cylinders to verify that the Cylinders are working throughout the stroke. Recheck tractor oil reservoir. Fully extend and fully retract the Fold and Lift Cylinders 5 or 6 times or more to purge air from the Hydraulic Circuit. If the cylinders are not working smoothly, fully extend the cylinders and continue to hold the lever to purge any remaining air.
5. Leave the Wing Fold Cylinders extended for installation.
6. Do Not loosen any hoses or fittings.
7. Recheck tractor reservoir to make sure it is within operating limits.

**Hydraulic Circuit approximate oil requirement:  
2 gallons**

## Wing to Frame Installation

1. Position the right hand wing frame between the right center frame bushings. Insert two Machinery Bushings on each side of the wing frame. Align the holes and insert Hinge Pin. Secure one end with 3/8-16 x 2-1/2 Bolt and Locknut and opposite end with 3/8 x 3 Roll Pin. **See Figure 2-14.**
2. Place one end of the link on the inside of each wing frame lug. Position spacer between links. Align the holes and insert 1 x 6 Pin. Place washers on the ends of the pin against the wing frame lug. Secure with 5/16 x 2 Roll Pins.
3. Position the other end of the link on each side of the fold cylinder rod clevis. Insert Roller Assembly between Rod Clevis, place a 1 inch Flat Washer on the outside of each Link. Align holes and slide 1 x 5-1/16 Pin through. Secure with 5/16 x 2 Roll Pins. Repeat procedure for the Left Hand Wing.
4. Insert the Grease Fittings into the holes on the top side of the Wing Hinge Tube.

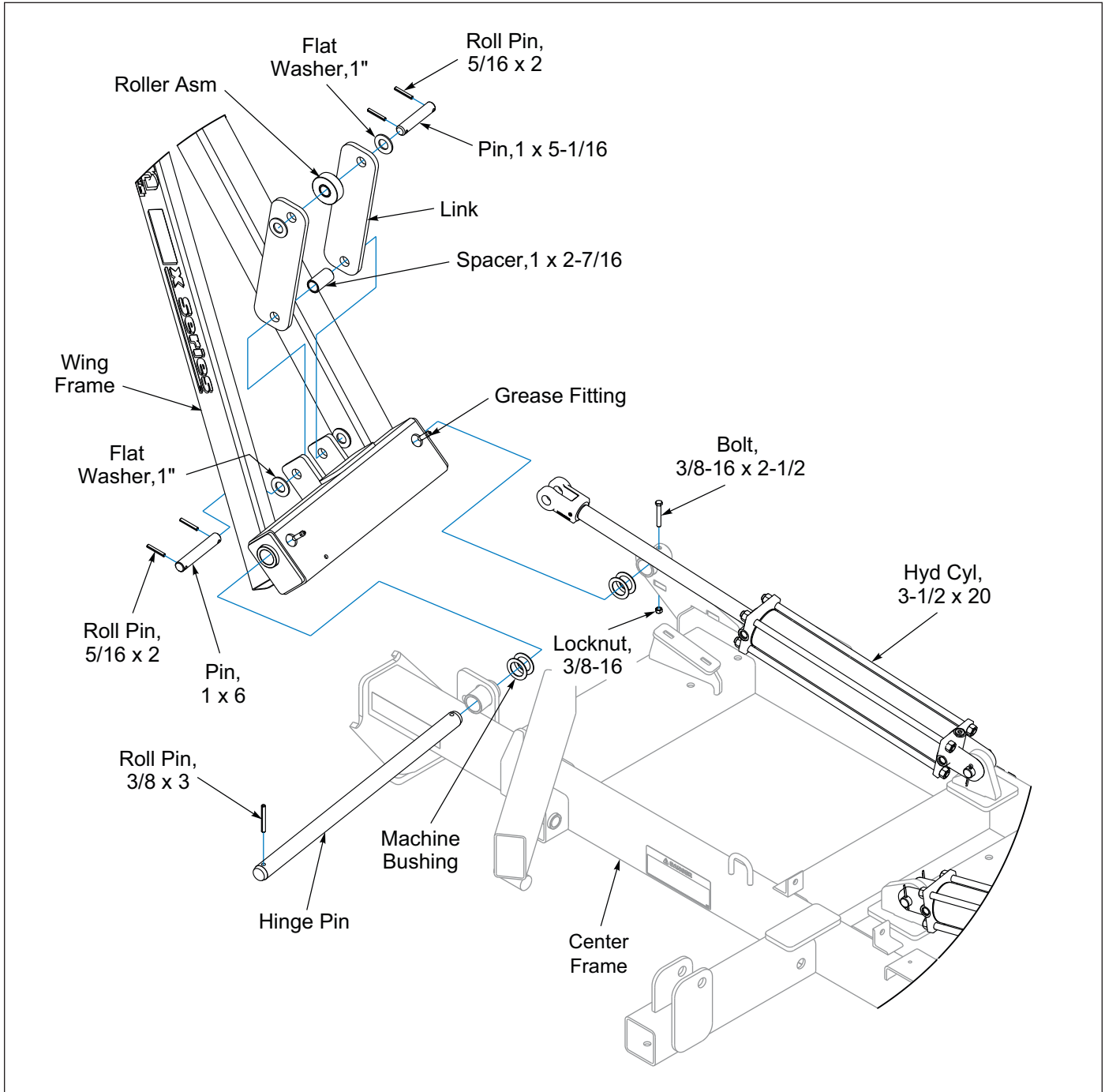

Figure 2-14: Wing to Frame Installation

# Transport Lock Linkage Assembly

1. At the rear of machine on the Right Hand Cylinder Lug place the Transport Lock Linkage Assembly Strap on the Fold Cylinder Base Pin and against the Cylinder Base Clevis, secure with Cotter Pin. **See Figure 2-15.**
2. Insert Transport Lock Linkage Eye Bolt into the hole on top of the Left Hand Wing Frame and secure with Lock Washer and Nut.

3. Attach the Transport Lock Linkage Cable End S-Hook to the Transport Lock. Pinch the S-Hook closed so it cannot come unhooked.

**NOTE**

*Ensure Linkage is not bent or kinked.*

If needed, adjust the Transport Lock Linkage Chain length by repositioning the S-Hook on the Chain, so that when the wings are folded, the Transport Lock is pulled down completely locking it into position.

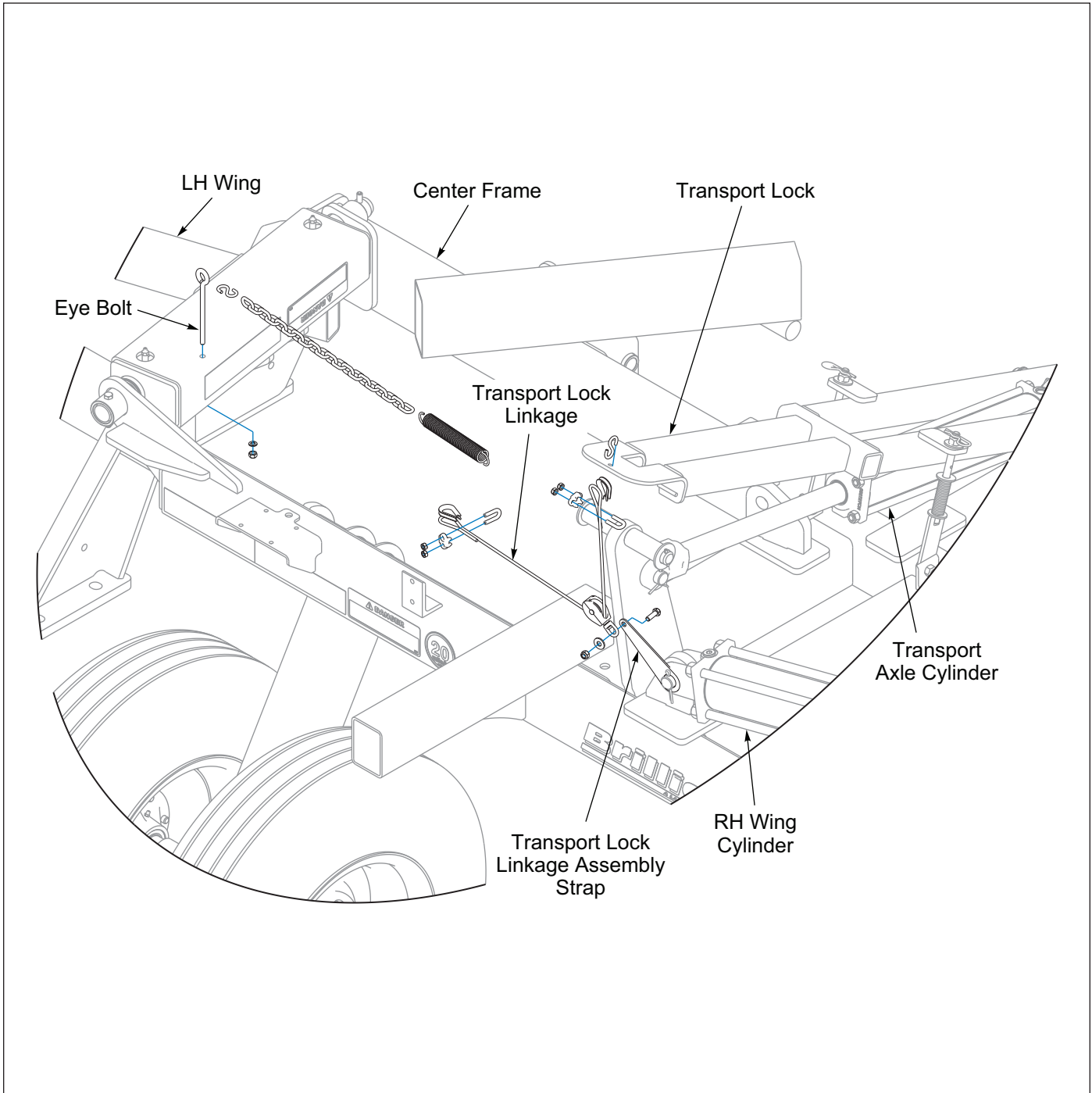

**Figure 2-15: Transport Lock Linkage**



## Wing Roller Assembly

1. Roller Assemblies are pre-assembled from the factory with stub shafts, bearings, shims, and retaining washers. **NOTE:** *Crowfoot Wheel Rotation Arrow must follow the direction of travel.* See **Figure 2-16.**

### NOTE

*Roller Axle Assembly clamped end must be on the outer extremity of the wing.*

2. Loosen the 1-8 Bolt on each end of the Roller Assembly approximately 4 turns.
3. With the Bearing Grease Fitting facing towards the rear of the machine, slide the Trunnion Bearing Mounts onto the Trunnion Bearings and lift the Roller Assembly up to the Wing Frame. Hand tighten 3/4-10 hardware to hold Trunnion Bearing Mounts in place.
4. Look at each Trunnion Bearing Mount to make sure that it is sitting perpendicular to the Center Frame Bearing Hanger. If not adjust the Shim Washers accordingly, for each side there are two 11ga and one 14ga Shim Washers. Shim Washers can be all three on the inside between the Stub Shaft shoulder and the Trunnion Bearing, all three can be on the outside between the Trunnion Bearing and Flat Top Washer, or a combination on either side, but all three must be used to minimize the gap. If gap cannot be properly minimized with bearing snap rings to outside, turn bearing around to have snap ring to inside. The bearing inner race is offset with respect to the trunnion bosses by 1/32". By installing bearings with snap rings in versus out, 1/16" difference can be made up at assembly if needed. See **Figure 2-17.**
5. Tighten 3/4-10 and 1-8 hardware to specification per torque chart. See **“General Torque Specifications” on page 4-1.**

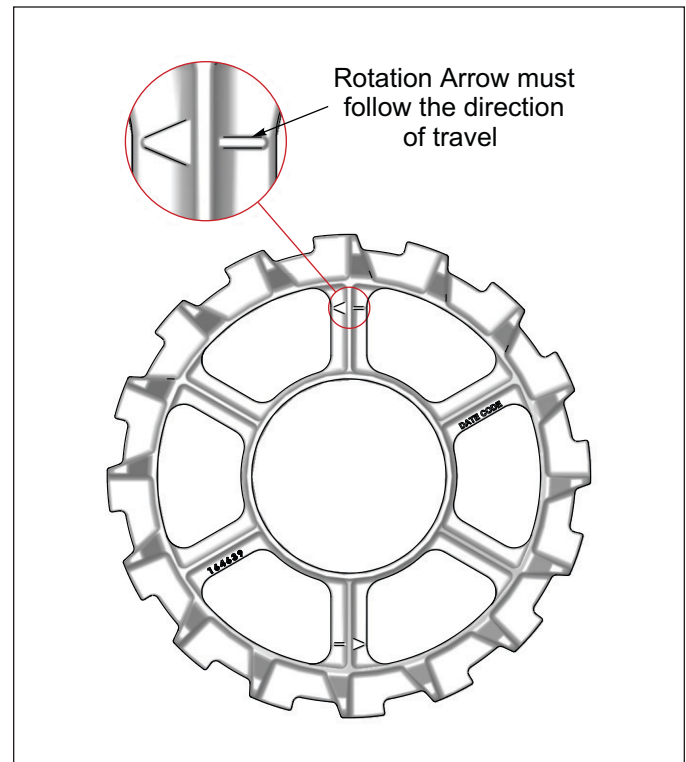

**Figure 2-16: Crowfoot Wheel Rotation Arrow**

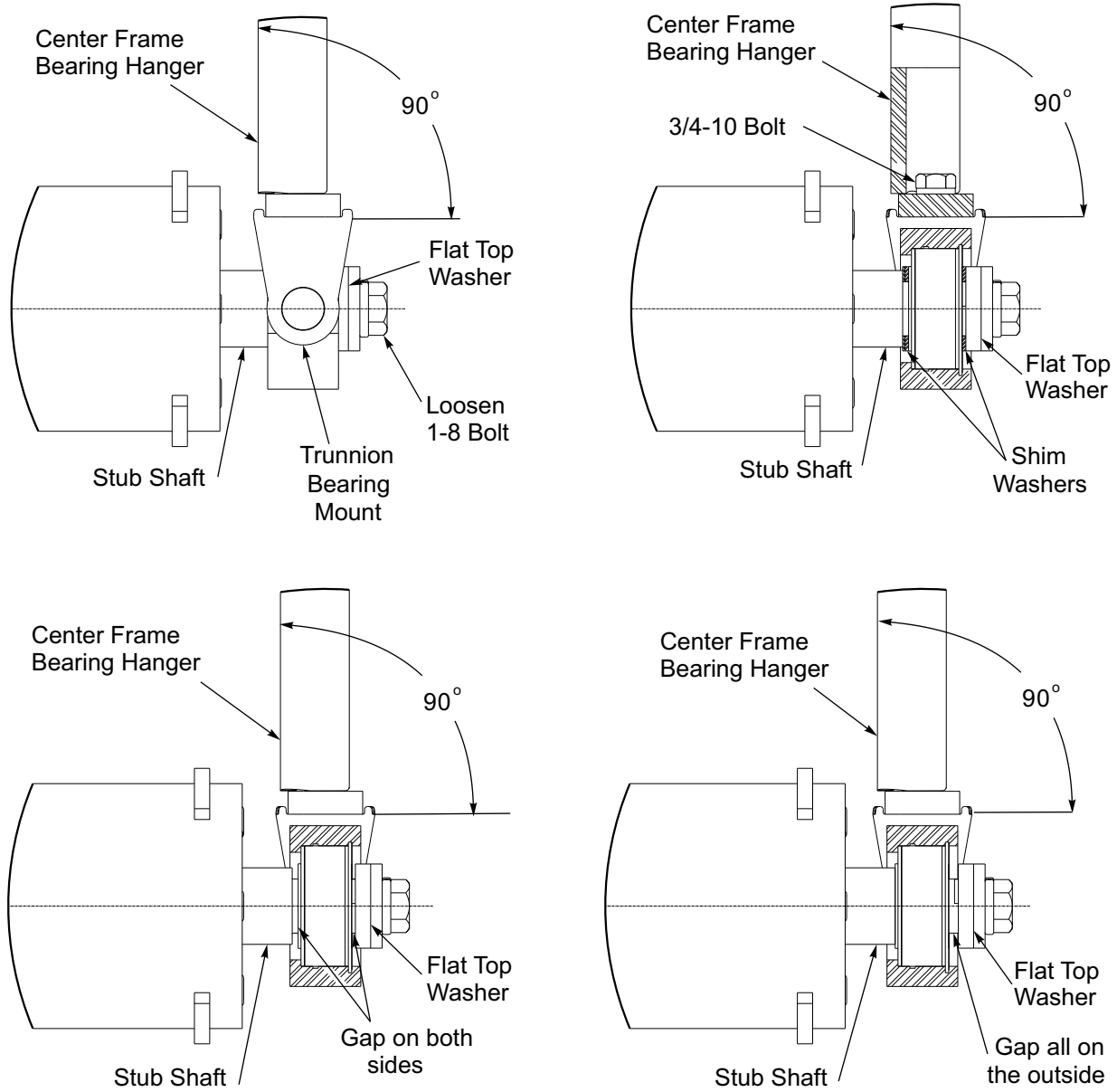

Figure 2-17: Trunnion Spacers

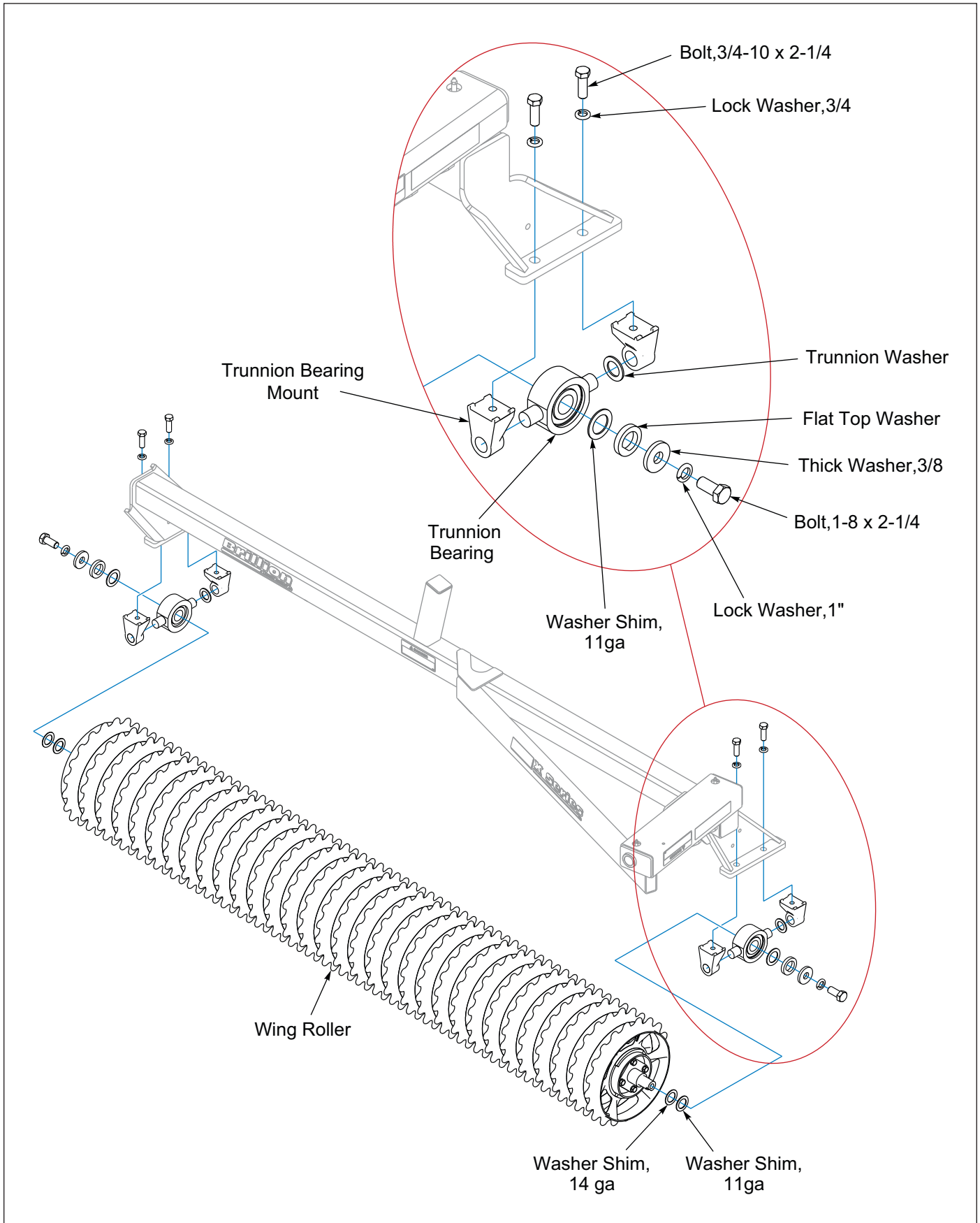

Figure 2-18: Wing Roller Assembly Installation

## Warning Lamp Installation

### **NOTE**

*Be sure when assembling Lamps onto Brackets that the wires are not pinched when tightening hardware.*

1. Attach Red Lamps with the lamp's red lens facing rearward, to the frame rear Light Brackets with 1/4-20 x 1-1/2 Bolts and Locknuts. **See Figure 2-19.** Ensure that each Lamp pigtail lays on top of the Bracket.
2. Attach the Flasher Control Module to the Module Bracket on the Front Frame Tube with 1/4-20 x 1-1/2 Bolts and Locknuts.

### **IMPORTANT**

**Cords are marked Left (Yellow Tape) and Right (Green Tape).**

3. Lay out the Warning Lamp Harness, noting that the connectors marked with Green Tape are for the Right Side and Yellow Tape are for the Left Side. Connect the Warning Lamp Harness to the Flasher Control Module.
4. On the Left side (Yellow Tape), lay the Warning Lamp Harness along the top of the front frame tube. Route the 3-Prong Cord connector end along the side of the frame cross tube and along the rear frame tube. Connect the Warning Lamp Harness to the Red Lamp.
5. Route the 2-Prong Cord connector end along the top of the front frame tube. Guide the connector end of the cord up and through the top of the Warning Lamp Bracket. Attach the Warning Lamp Bracket to the frame with 1/2-13 U-Bolt, Flat Washers and Locknut.
6. Position the Amber Lamp inside the Warning Lamp Bracket Shield and connect Warning Lamp Harness and Amber Lamp Connectors. Attach the Amber Lamp to the Warning Lamp Bracket with 1/4-20 x 1-1/2 Bolts and Locknuts.
7. Repeat for the Right Side (Green Tape).
8. Connect the 7-Pin Ag Harness to the Flasher Control Module. Route the 7-Pin Ag Harness along the Drawbar with the Hydraulic Hoses through the Hose Support up to the tractor.
9. Bundle and secure excess harness cords to the Module Bracket, Warning Lamp Brackets, along the Pulverizer Frame, Drawbar and Hydraulic Hoses with Tie Wraps allowing enough harness length to reach the Tractor Socket.

### **IMPORTANT**

**All Harnesses must be firmly attached to machine frame members or Hydraulic Hoses so they do not sag or become torn loose by field debris. Use the tie wraps provided.**

**Check to be sure the Harnesses are slack enough so as to not be stretched or interfered with while raising and lowering of the machine.**

### **NOTE**

*The 7-Pin Harness connects to the tractor socket when in use. Allow enough harness length to reach tractor socket. Roll or fold up excess and secure to hydraulic hoses or Drawbar.*

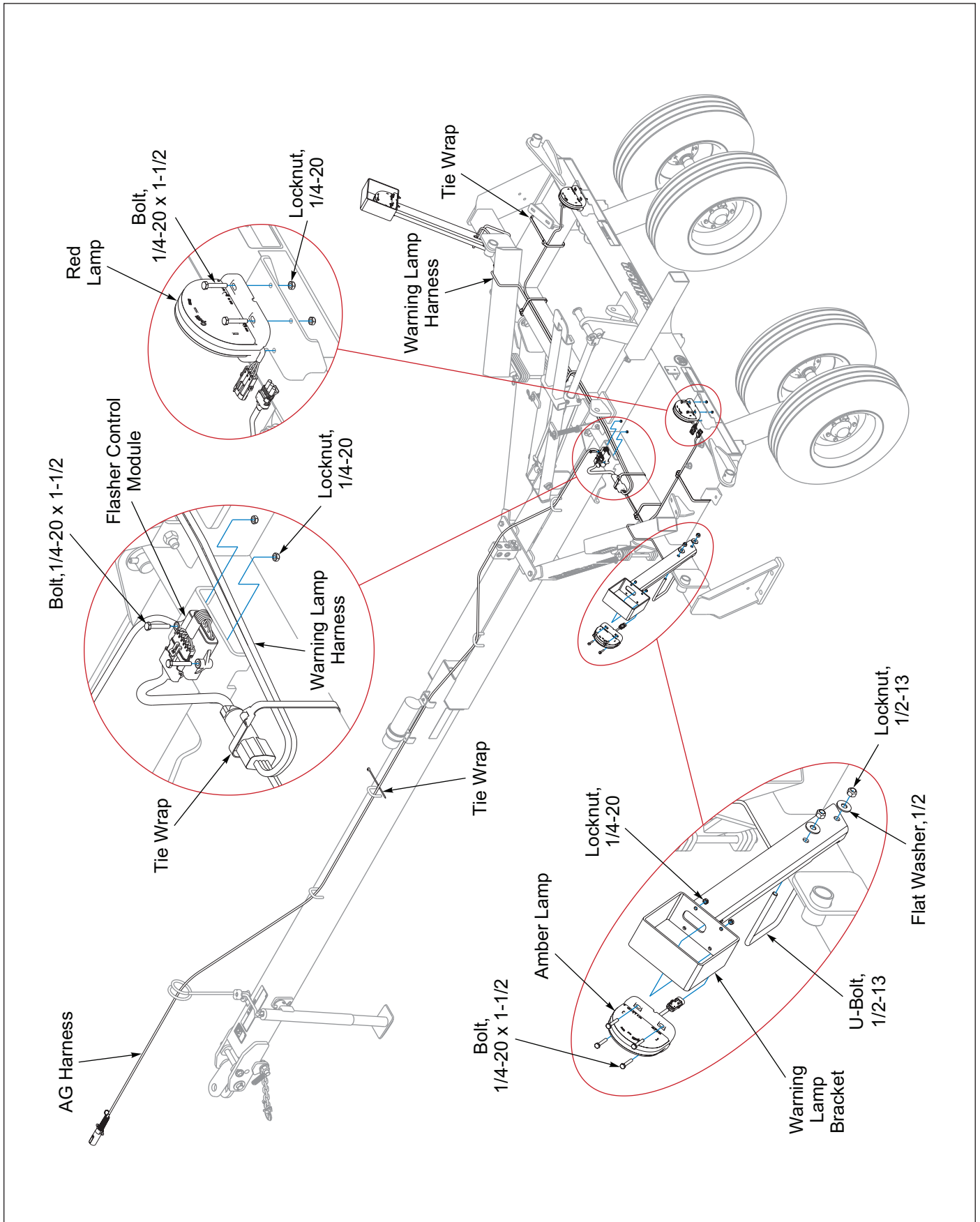

Figure 2-19: Electrical Layout

# Center Notch Wheel Scraper - Optional

Heavy Notch Wheel Scraper assembly is similar.

**NOTE**

*A scraper can be used as a guide to achieve the 1/4" gap between the Scraper and Notched Wheel.*

1. Place Center Roller on level ground. Install the 1/2-13 x 1-3/4 Bolts through the center and outer frame angles and Center Scraper Brackets with Flanged Locknuts. **See Figure 2-20.** Do not tighten.
2. Short Scrapers are used to allow clearance for the Transport Axle Lift Arm and Center Scraper Bracket
3. Attach the remaining Scrapers to the Scraper Tube with 3/8-16 U-Bolts and Flanged Locknuts. The Scrapers must be centered between the Notched Wheels along with a 1/4" gap between the Scraper and Notched Wheels. **See Figure 3-8.** Tighten all hardware.

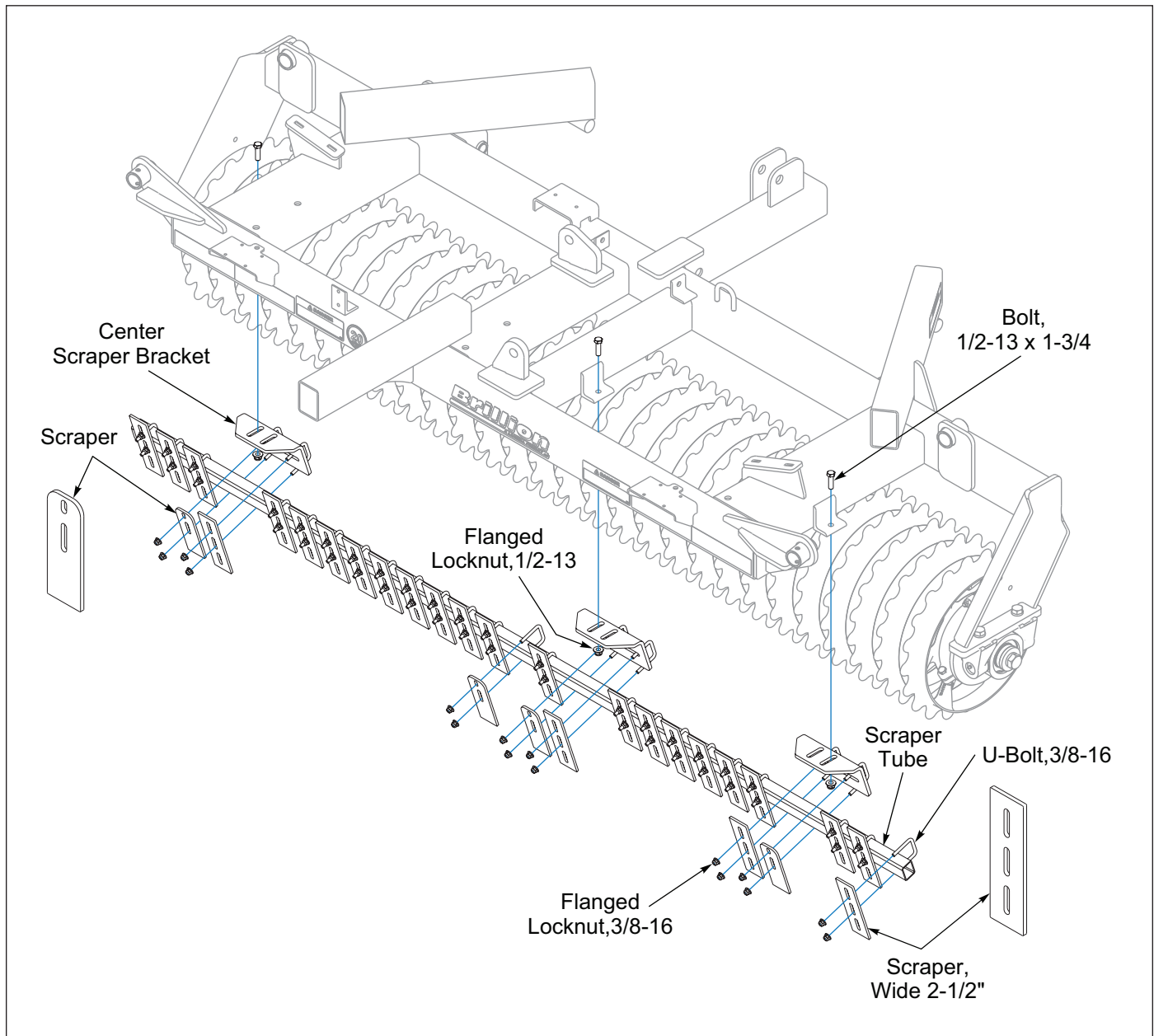

**Figure 2-20: Center Scraper Installation**

# Wing Notch Wheel Scraper - Optional

Heavy Notch Wheel Scraper assembly is similar.

Right Hand Shown, Left Hand similar.

**NOTE**

A scraper can be used as a guide to achieve the 1/4" gap between the Scraper and Notched Wheel.

1. Place Wing Rollers on level ground. From the front of the Wing Frame Tube, assemble the 1/2-13 U-Bolts over the wing frame tube and through the Wing Scraper Brackets with Flanged Locknut. **See Figure 2-21.** Do not tighten.
2. Attach the Scraper Tube Bracket to the Wing Scraper Bracket with 1/2-13 x 1-3/4 Bolts, Flat Washers, and Flanged Locknuts. Pull the Scraper Tube Bracket as

- far towards the rear as possible. Tighten 1/2-13 x 1-3/4 Bolts.
3. Center the Scraper Tube over the length of the Wing Roller. Place the 3/8-16 U-Bolts as close as possible to the Scraper Tube Bracket flange bend. Assemble the Scraper Tube to the Scraper Tube Brackets with a 3/8-16 U-Bolts, Scrapers, and Flanged Locknuts. Adjust the Wing Scraper Bracket as needed to center the Scrapers between the Notched Wheels and adjust the Scrapers so that there is a 1/4" gap between the Scraper and Notched Wheels. **See Figure 3-8.** Tighten all hardware.
4. Attach the remaining Scrapers to the Scraper Tube with 3/8-16 U-Bolts and Flanged Locknuts. The Scrapers must be centered between the Notched Wheels along with a 1/4" gap between the Scrapers and Notched Wheels.

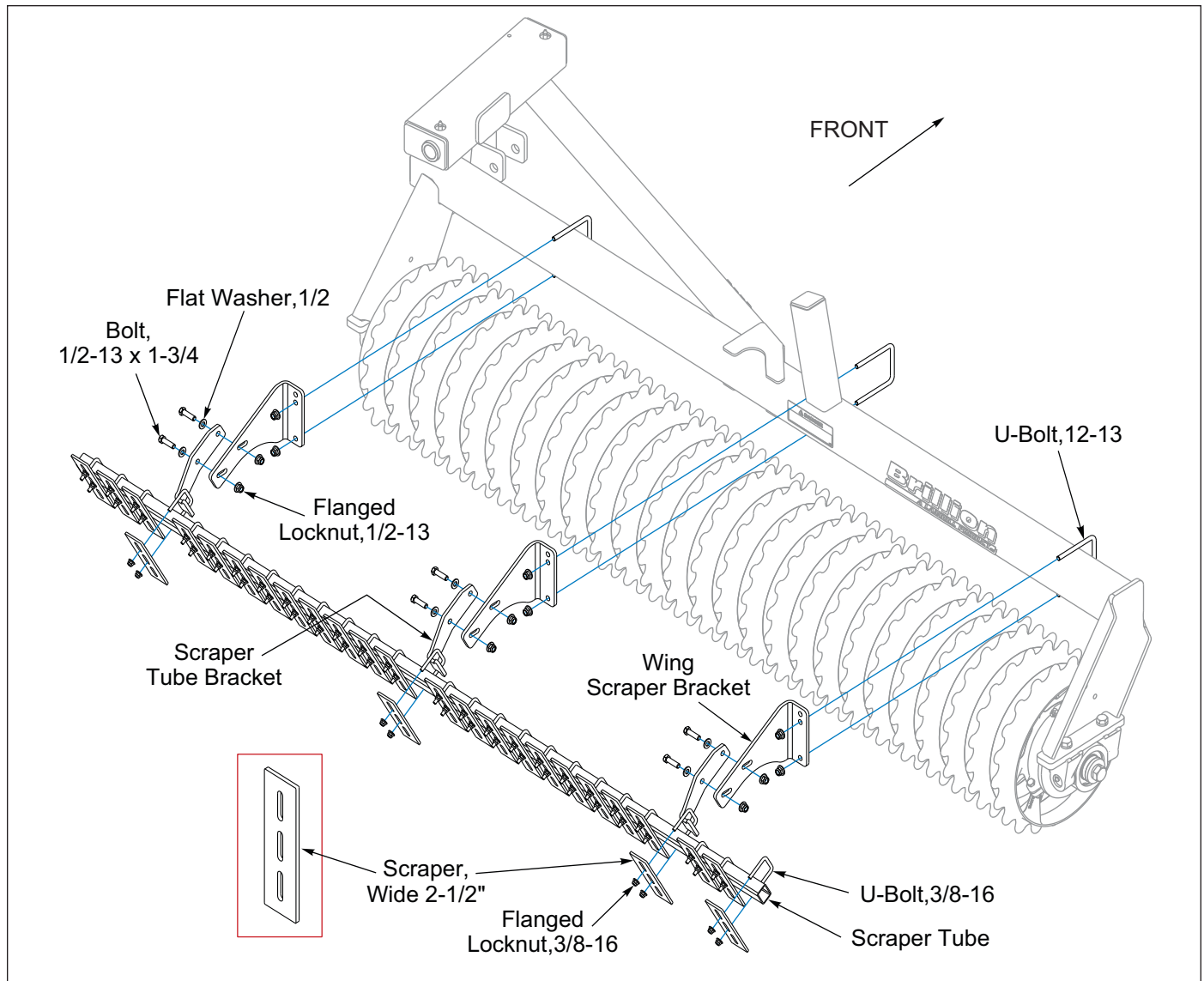
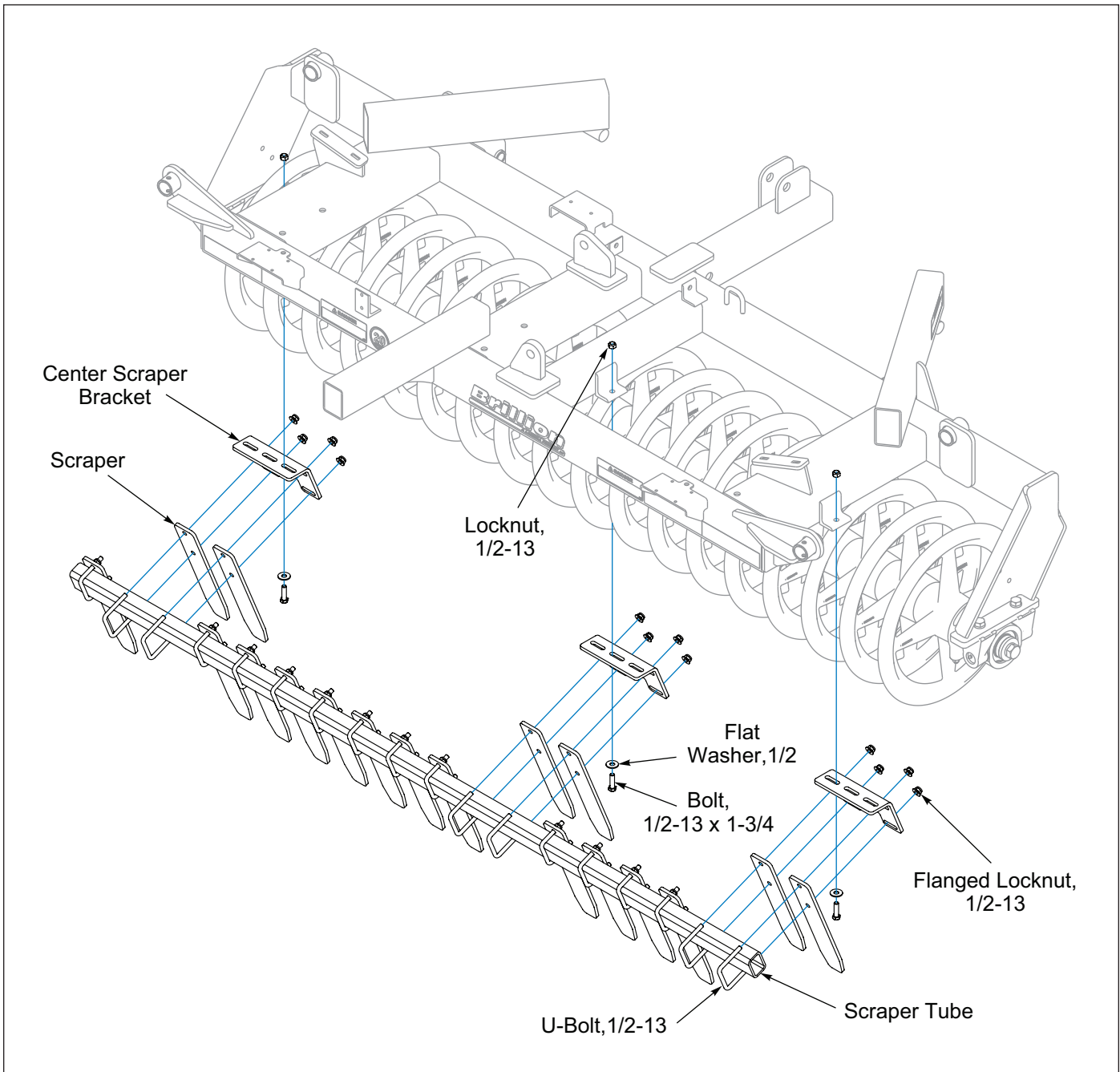

Figure 2-21: Wing Scraper Installation

# Center V-Wheel Scraper - Optional

1. Place the Center Roller on level ground. Place a Flat Washer on the 1/2-13 x 1-3/4 Bolts. Install 1/2-13 x 1-3/4 Bolts through the Center Scraper Brackets and inner and outer frame angles with Locknuts. **See Figure 2-22.** Do not tighten.
2. The Scraper Assembly is pre-assembled with Scrapers attached to the Scraper Tube. Lay the Scraper Assembly behind the Center Roller so the Scrapers are inward (against the Center Scraper Bracket).
3. Remove the 1/2-13 Flanged Locknuts where the corresponding U-Bolts will attach the Scraper Tube to the Center Scraper Brackets. Center the Scrapers between the V-Wheels and mount the Scrapers and Scraper Tube to the Center Scraper Brackets with 1/2-13 U-Bolts and Flanged Locknuts adjusting the Center Scraper Brackets on the frame if necessary. Tighten all hardware.
4. Center all Scrapers between the V-Wheels.



**Figure 2-22: Center V-Wheel Scraper**



# Wing V-Wheel Scraper - Optional

Right Hand Shown, Left Hand similar.

1. Place the Wing Rollers on level ground. From the front of the Wing Frame Tube, assemble the 5/8-11 U-Bolts over the wing frame tube and through the Wing Scraper Brackets with Flanged Locknuts. **See Figure 2-23.** Do not tighten.
2. The Scraper Assembly is pre-assembled with Scrapers attached to the Scraper Tube. Lay the Scraper Assembly behind the Wing Roller so the Scrapers are outward when attached to the Wing

3. Loosen the Flanged Locknuts where the corresponding 1/2-13 U-Bolt will attach the Scraper Tube to the Wing Scraper Brackets. Position the 1/2-13 U-Bolts as close as possible to the Wing Scraper Bracket flange bend by adjusting the Wing Scraper Brackets. Center the Scrapers between the V-Wheels and mount the Scraper Tube to the Wing Scraper Brackets by tightening the Flange Locknuts. Tighten Wing Scraper Bracket 5/8-11 hardware.
4. Center all Scrapers between the V-Wheels.

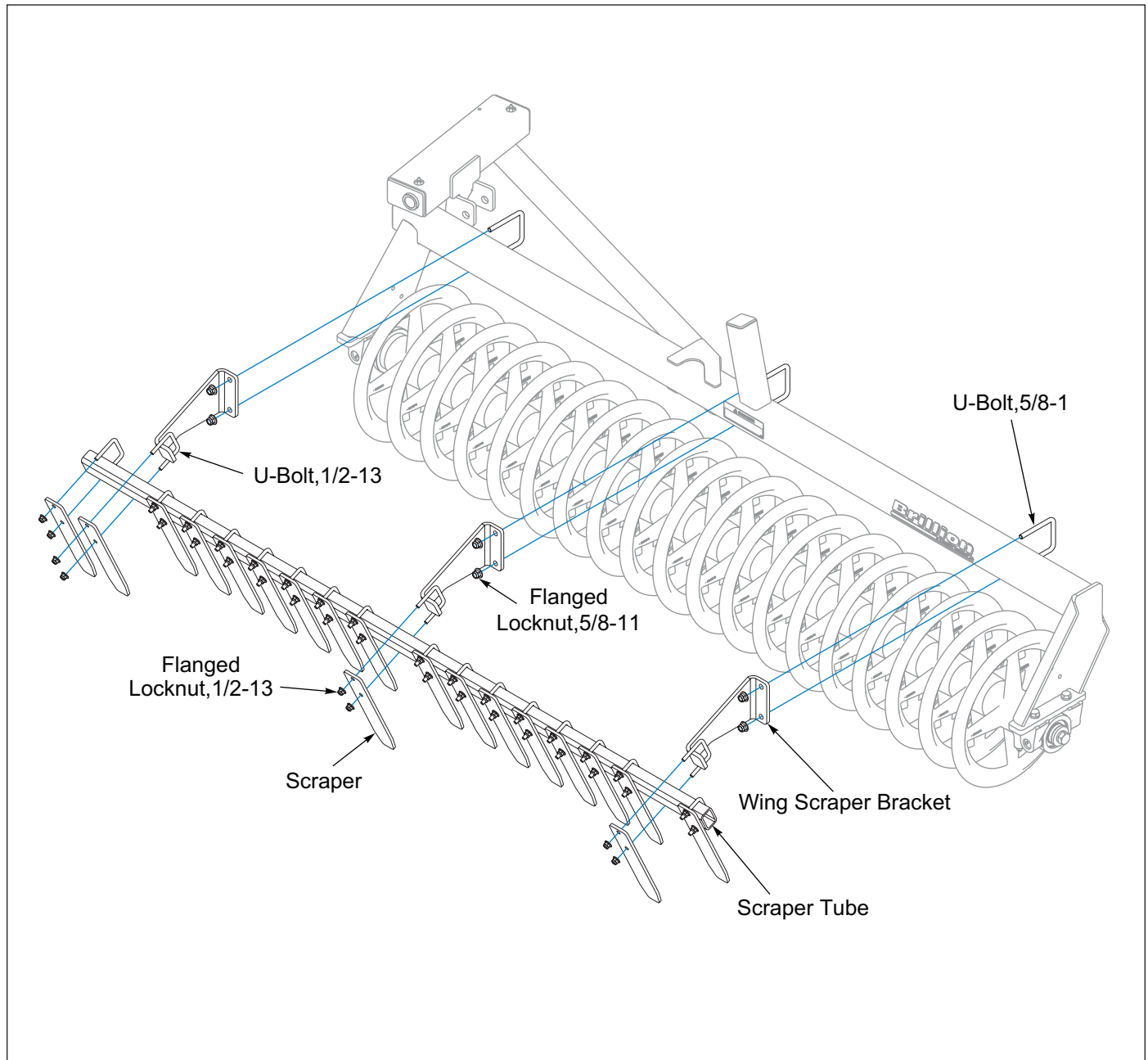

**Figure 2-23: Wing V-Wheel Scraper**

## Acre Meter - Optional

**IMPORTANT**

Unfold and lower machine prior to performing any steps.

1. Attach the Acre Meter Assembly to the front frame tube using 5/8-11 U-Bolt and Locknuts. **See Figure 2-25.**
2. Attach the Acre Meter Switch to the Acre Meter Bracket using #8-32 x 1-1/4" Screws, Flat Washers, Lock Washers, and Hex Nuts. Attach the short Pick-Up Switch Ground Wire under one of the screw heads, removing paint under the wire connector to assure a good electrical ground connection. **Do not tighten at this time.** Set aside.
3. Remove the existing 1- 8 x 2-1/4 bolt, 1" Lock Washer and 3/8" Thick Washer from the roller end. Slide existing Lock Washer, a 3/8" Thick Washer, magnet wheel and existing 3/8" Thick Washer onto 1-8 x 3 Bolt. Insert into end of roller and fully tighten.
4. Remove the existing Trunnion Bearing Bolts and Lock Washers from Bearing Hanger. Place the Acre Meter Bracket onto the Bearing Hanger and re-install existing Trunnion Bearing Bolts and Lock Washers. Fully tighten.

5. Adjust the Acre Meter Switch so the center line of Magnet Wheel and Pick-Up Switch are horizontally and vertically aligned with a maximum 1/8" between Magnet Wheel and Pick-Up Switch. Now firmly tighten all screws. **See Figure 2-24.**

**NOTE**

*Alignment of Pick-Up Switch and Magnet Wheel is critical. Improper alignment will cause the acre counter to record acres erratically or not at all.*

6. Route the wire from the acre meter across the front frame to the Acre Meter Switch and connect the mating plugs.
7. Secure harness to existing light harness with tie straps to prevent harness from rubbing or becoming entangled. Install Hose Clamp into 1/2" hole in the Trunnion Bearing Plate with 3/8-16 x 1-1/4 Bolt, Flat Washer and Locknut and Nut.

**See Page 3-8** for Acre Meter Programing.

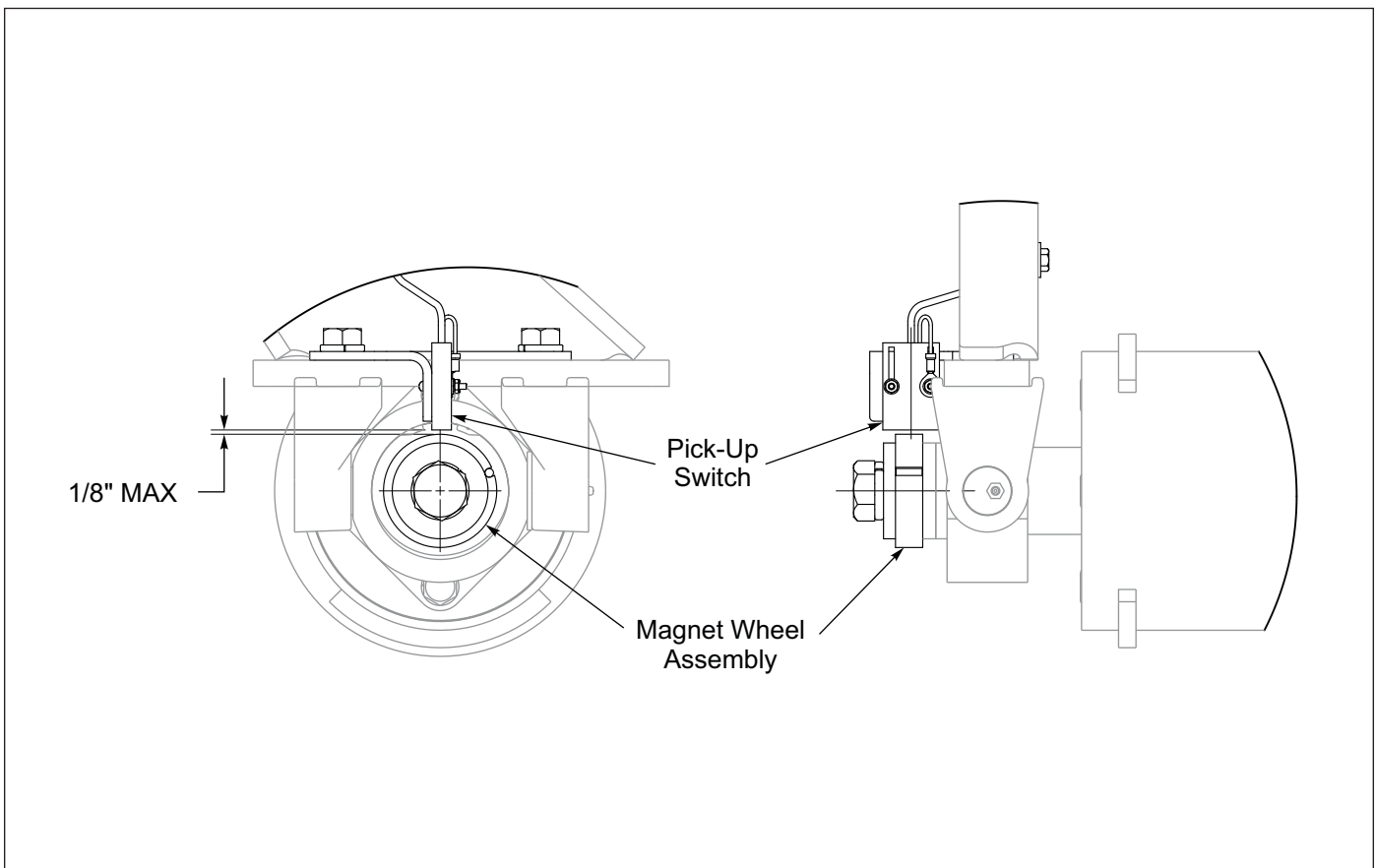

**Figure 2-24: Pick-Up Switch Side View**

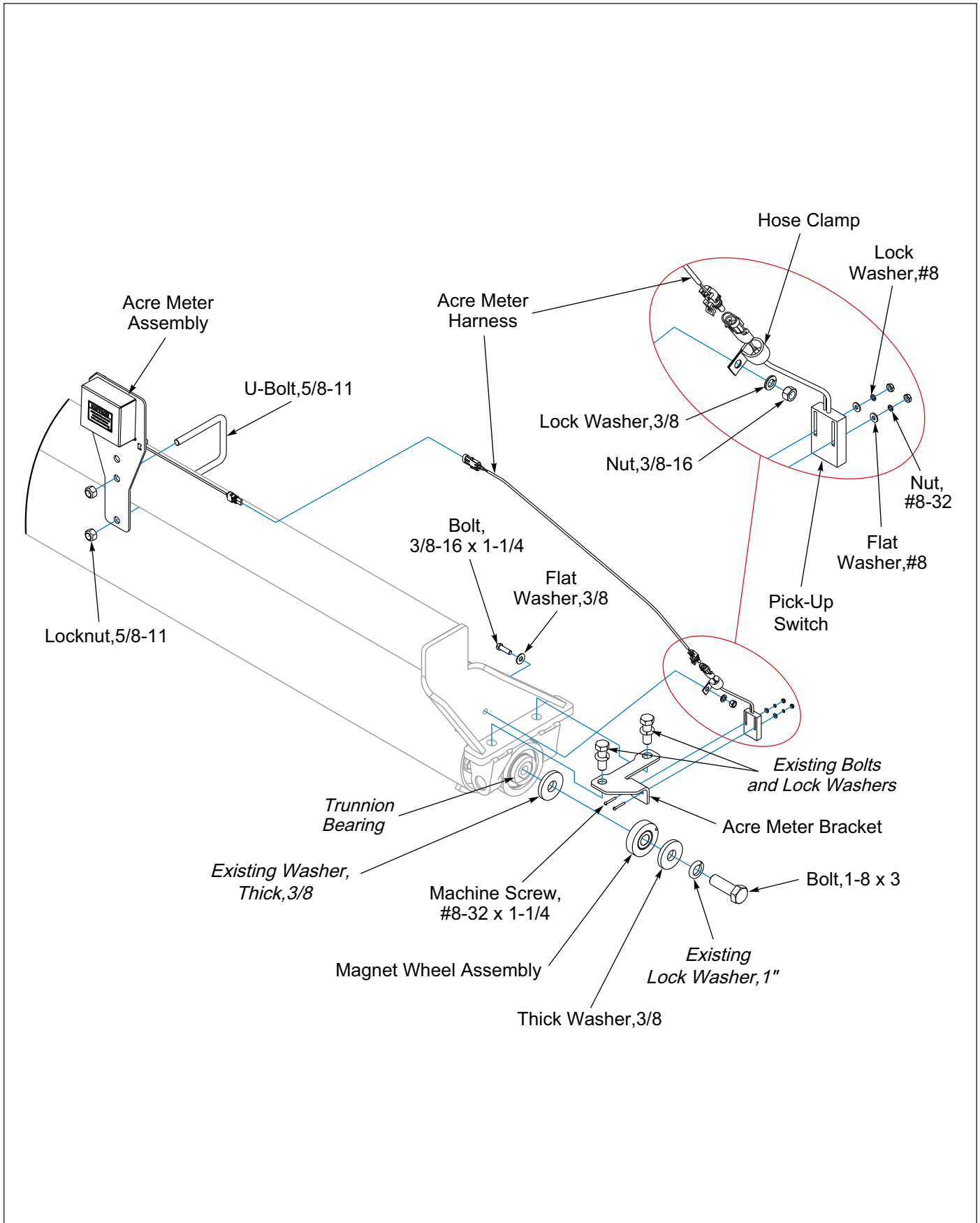

Figure 2-25: Acre Meter Installation

# Weight Kits - Optional

## Kit 194085 Single Weight Kit

## Kit 194600 Double Weight Kit

1. Weights should be mounted as close to the outer end of the wings as possible. They may be mounted with one weight per wing (Approx. 115 lbs) or two weights per wing. Weights can be positioned either above or below or front or rear of wing tube. Use the orientation that will provide the most clearance.

2. After attaching weights, fold the wings slowly to check for interference between the weights and transport lock or opposite wing when folded, adjust as necessary.

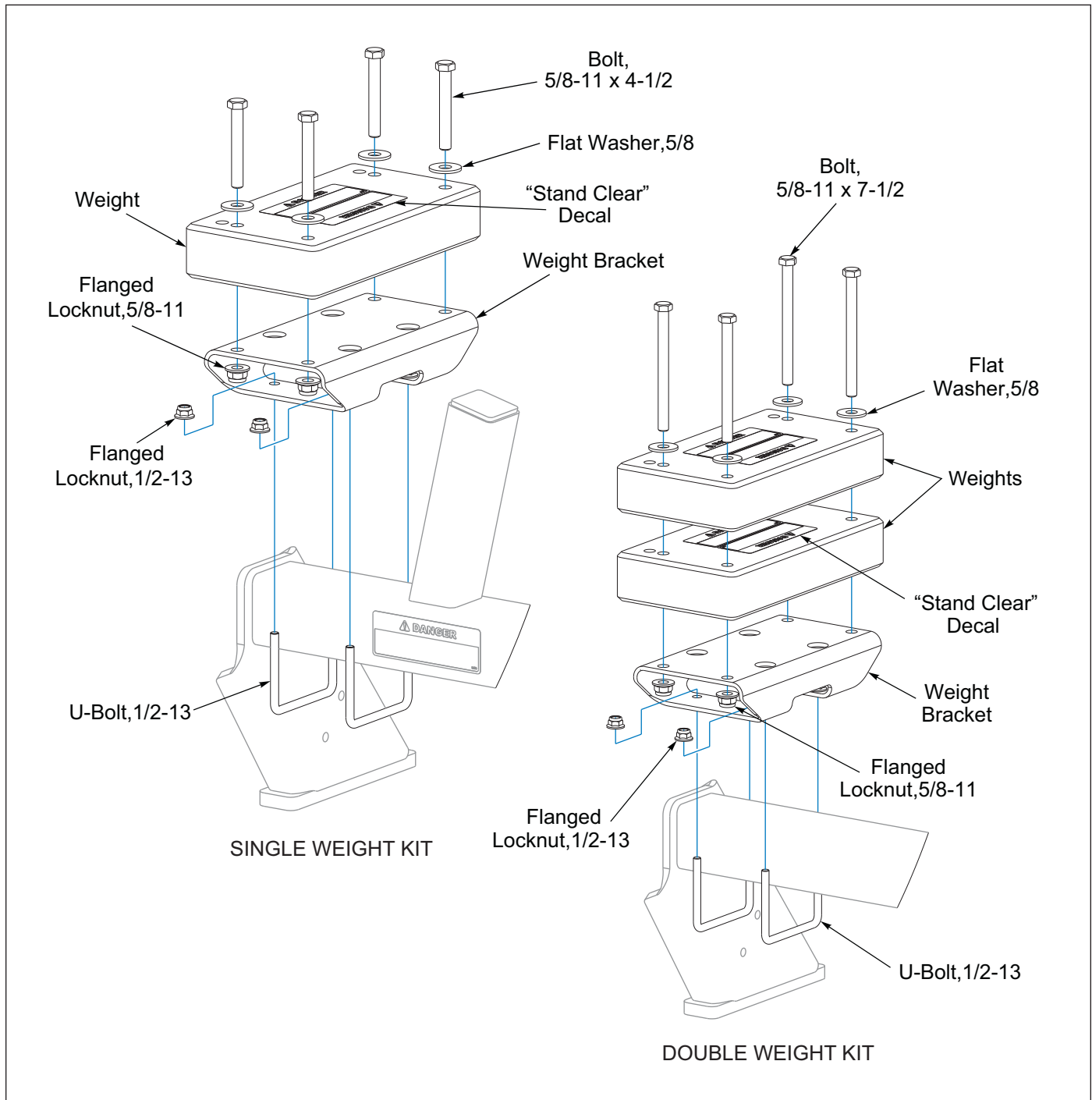

Figure 2-26: Weight Kits

**DANGER**

Never allow anyone a ride on the Pulverizer at any time. Allowing a person to ride on the machine can inflict serious personal injury or death to that person.

**WARNING**

All hydraulically elevated equipment must have cylinder lockouts installed or be lowered to the ground, when servicing or when equipment is idle. Failure to take preventative measures against accidental lowering can result in serious personal injury.

**DANGER**

Always lock the tractor drawbar in the center position when transporting the unit. Failure to do so can result in serious injury or death and cause damage to the equipment.

**DANGER**

When transporting the unit, raise and fold the Pulverizer. Once completely raised and folded, the Transport Lock will automatically engage the Lift System. Lock the Transport Lock in place by inserting the Hairpin Cotter in the Spring Holders bottom hole. Failure to lockout the cylinder can cause the unit to settle during transport, which can result in serious injury or death and cause damage to the equipment.

**CAUTION**

When transporting farm implements on public roads, it is the responsibility of the operator to abide by state and local laws concerning wide loads, speed, safety emblems and safety lighting equipment. Drive at safe speeds, particularly when rounding corners, crossing rough ground or driving on hillsides, to prevent tipping the tractor.

## Tractor Preparation

The Brillion Pulverizer is designed to be pulled by a tractor equipped with or without a hammer strap. See "Safety Chain" on page 1-4.

Before attaching the implement, prepare the tractor as follows:

1. Inflate the rear tractor tires equally and add ballast according to the tractor operator's manual.
2. Lock the Tractor Drawbar in the center position.

## Pulverizer Preparation

1. Prior to operating the Pulverizer, inspect it thoroughly for good operating condition.
2. Replace worn or missing parts.
3. When the machine is new, check the bolt tightness after a few hours of operation. Tighten any loose nuts or bolts. Check the lift wheel lug bolts daily.
4. Check the lift wheel tire inflation. Inflate all tires equally to avoid side draft. Follow the tire manufacturer's recommended pressures listed on the sidewall of the tires.

**OPERATION**

## Attaching to the Tractor

1. Align the Tractor Drawbar with the machine. Raise or lower the hitch, as needed, using the Jack. Attach the unit with proper size hitch pin. **See Table 3-1.**
2. Always swing the jack to the up position and pin it before setting the machine in motion.
3. Clean all hydraulic couplings and attach to the tractor.
4. Fully extend the Hydraulic Lift Cylinders, and retract the Wing Fold Cylinders. Transport Lock will engage when Lift Cylinder is extended. Secure Transport Lock with Hairpin Cotter. **See Figure 3-4.**
5. Attach Safety Chain to tractor allowing plenty of movement for turning both directions. The Safety Chain should latch securely to prevent it coming loose. **See "Safety Chain" on page 1-4.**
6. Connect the 7-Pin Connector for the lights.
  - Make sure the tractor has a good clean receptacle, free of dirt and corrosion.
  - Make sure the 7-Pin Connector is inserted ALL the way in. With tighter fitting pins, operator may think the connector is all the way in, but really isn't.
  - Make sure the tractor receptacle cover latches over the keyway on the 7-Pin Connector to hold the connector in place.
  - If an operator plugs in the 7-Pin Connector, but the lights do not seem to work right, check the above items to make sure there is a good connection with the 7-Pin Connector.

DRAWBAR CAT	Min Pin Size	Max PTO HP
2	1-1/4" (30mm)	154 (115 Kw)
3	1-1/2" (38mm)	248 (185 Kw)

**Table 3-1: Hitch Pin Size**

## Hitch Lock

The Hitch Lock prevents the hitch from moving in either the Spade or Clevis position. *Note the different orientation of the Hitch Lock.*

- In the **Spade Position** insert the Hitch Lock into the clevis end opening. Secure the Hitch Lock with 1 x 9-1/4 Pin and 1/4 x 1-1/4 Lynch Pin. **See Figure 3-1.**
- In the **Clevis Position** insert the spade end of the hitch into the Hitch Lock opening. Secure the Hitch Lock with 1 x 9-1/4 Pin and 1/4 x 1-1/4 Lynch Pin. **See Figure 3-2.**

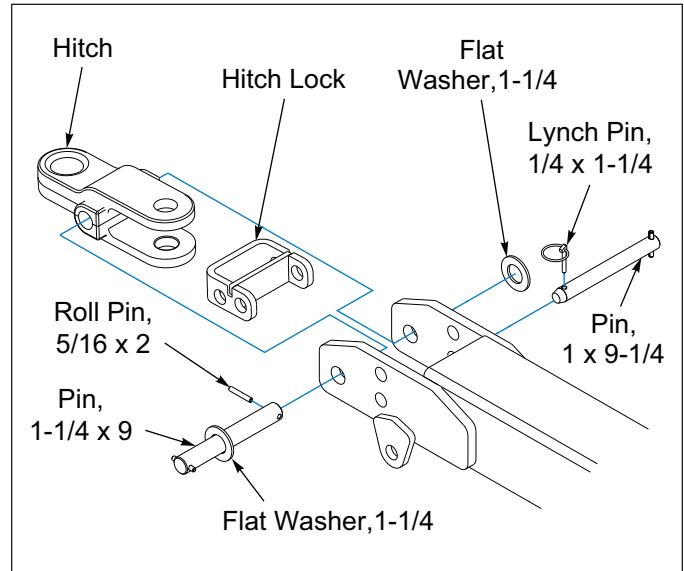

**Figure 3-1: Spade Position**

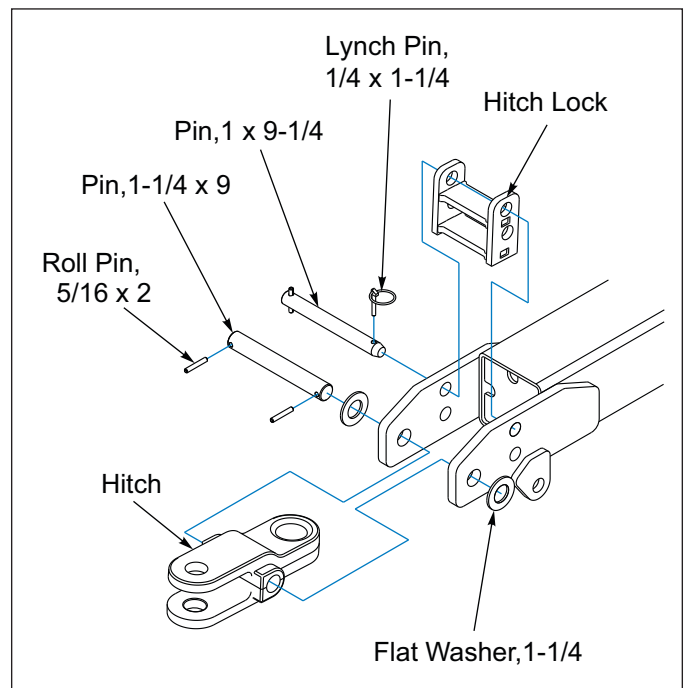

**Figure 3-2: Clevis Position**

# Hydraulic System

## IMPORTANT

Unfold and lower the unit to the ground and relieve system pressure before attempting to repair, adjust, or disconnect components.

## NOTE

Never unfold the wings past center until all air is out of the hydraulic circuit, as free-falling may occur.

The Pulverizer is equipped with a single hydraulic circuit that folds/unfolds the wings and raises/lowers the machine.

## WARNING

Escaping fluid under pressure can be nearly invisible and have enough force to penetrate the skin causing serious injury. Relieve system pressure before repairing, adjusting, or disconnecting. Use a piece of cardboard, rather than your hands, to search for suspected leaks. See Figure 3-3. Wear protective gloves & safety glasses or goggles when working with hydraulic systems. Keep all components (cylinders, hoses, fittings, etc.) in good repair.

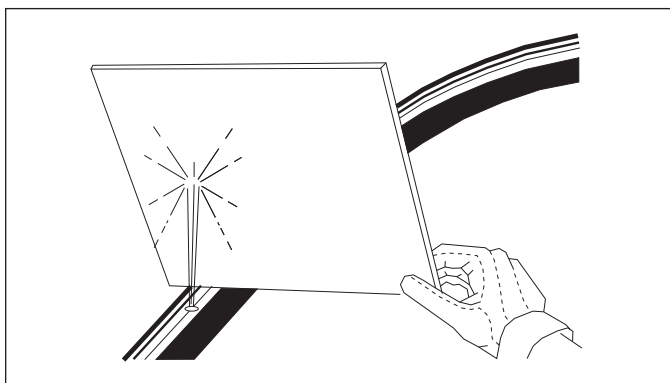

Figure 3-3: Hydraulic Leak Detection

## DANGER

Falling wings can cause injury or death. Stand clear when wings are being raised or lowered.

## DANGER

Bleed the air from Wing Lift Cylinders before operating. Failure to do so will allow wings to free-fall and may cause serious personal injury. See Operator's Manual for correct procedure.

- The wing fold cylinders are equipped with restrictors to prevent uncontrolled falling of wing frames when unfolding. Removal or improper assembly of these restrictors can cause the machine to fold improperly and result in serious machine damage.
- Whenever raising/folding or lowering/unfolding, find a level area large enough to accommodate the unit when it is fully unfolded. The tractor should be stopped and not moving with the unit fully raised.
- On level ground, unfold the wings completely and lower machine to the ground. Make sure the Wing Cylinders are extended completely and the Transport Axle Cylinder is retracted. The Cylinders should be working smoothly through the stroke, if not purge the system. "Purging the Hydraulic System" on page 2-18 Air in the system can allow uncontrolled dropping of the Wing Frames causing serious personal injury or machine damage. The system needs to be charged with oil initially and any time the system has been opened for repair such as cylinder, hose, or fitting replacement/repair.
- Do not loosen hoses/fittings after the Hydraulic Circuit has been purged.
- Recheck tractor reservoir oil level.

# General Operation

## DANGER

Watch out for Overhead Electrical Wires and other Overhead Obstructions when folding and unfolding Pulverizer Wings.

1. Horsepower requirements will vary due to speed, moisture, residue and types of soils. Local dealers can help in making recommendations for your conditions.
  - The minimum horsepower requirement as an Independent Tool is 3-5 horsepower per foot of rolling width.
  - The minimum horsepower requirement as a Companion Tool is 1-3 horsepower per foot of rolling width.
2. Operating speed is 5-8 mph. Reduce speed in rocky conditions to prevent wheel breakage.
3. During field operation, it is not necessary to raise the machine for turns, but turns should be as wide as possible.

# Operation of Transport Lock

**IMPORTANT**

Be sure Transport Lock is either locked or unlocked.

**NOTE**

Adjust the Transport Lock Linkage Chain length by repositioning the S-Hook on the Chain if the Transport Lock fails to pull down completely and lock in position.

## Field to Road

1. Actuate the tractor hydraulic lever to raise the center and fold the Wings for transport.
2. When the Pulverizer is raised and folded, the Transport Lock automatically engages the Lift System by cable/spring linkage.
3. Remove the Transport Lock Hairpin Cotter from the top hole of the Spring Holder and insert it into the bottom hole locking the Transport Lock in place. **See Figure 3-4.**
4. Relieve hydraulic pressure before disconnecting from the tractor.

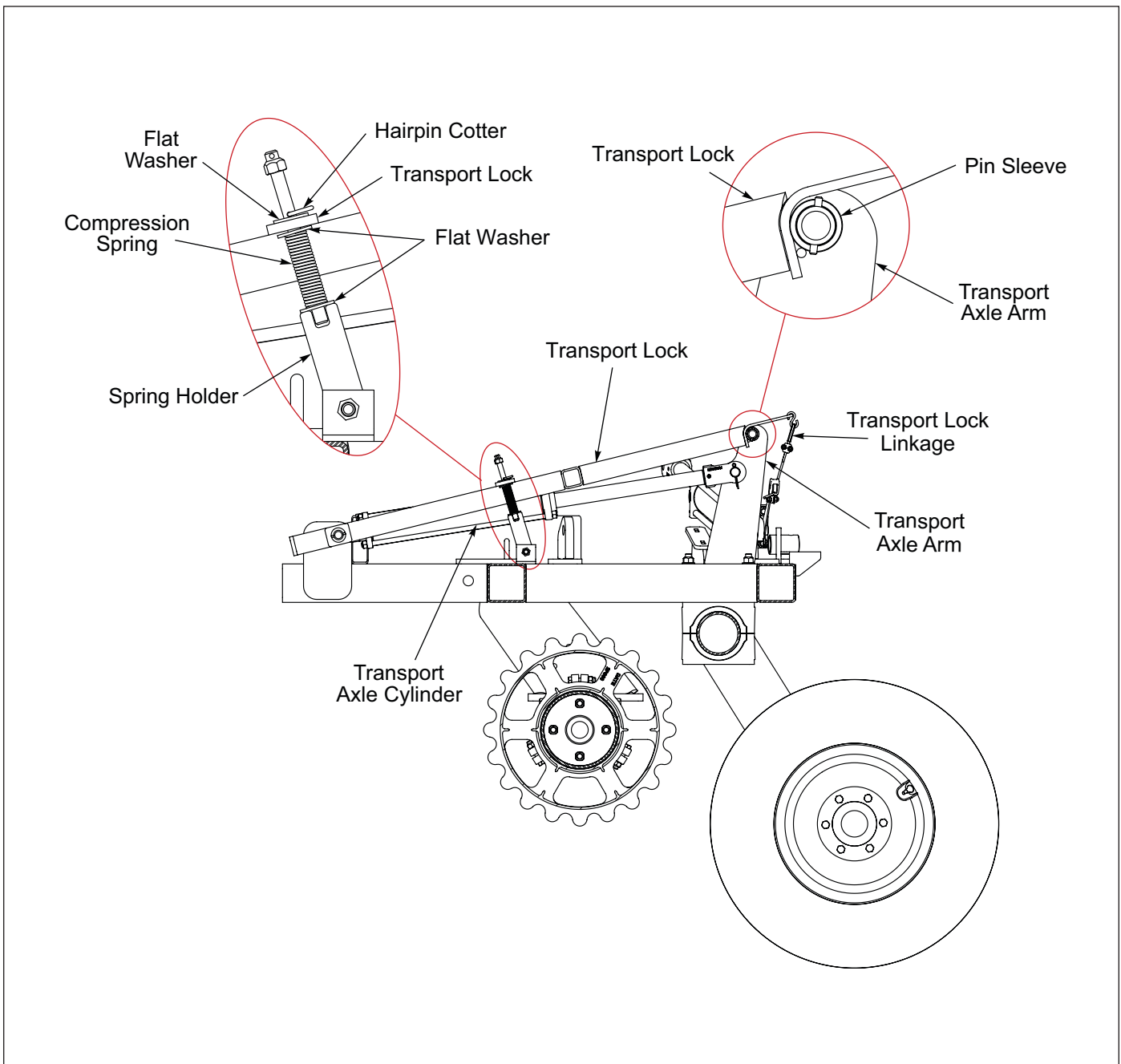
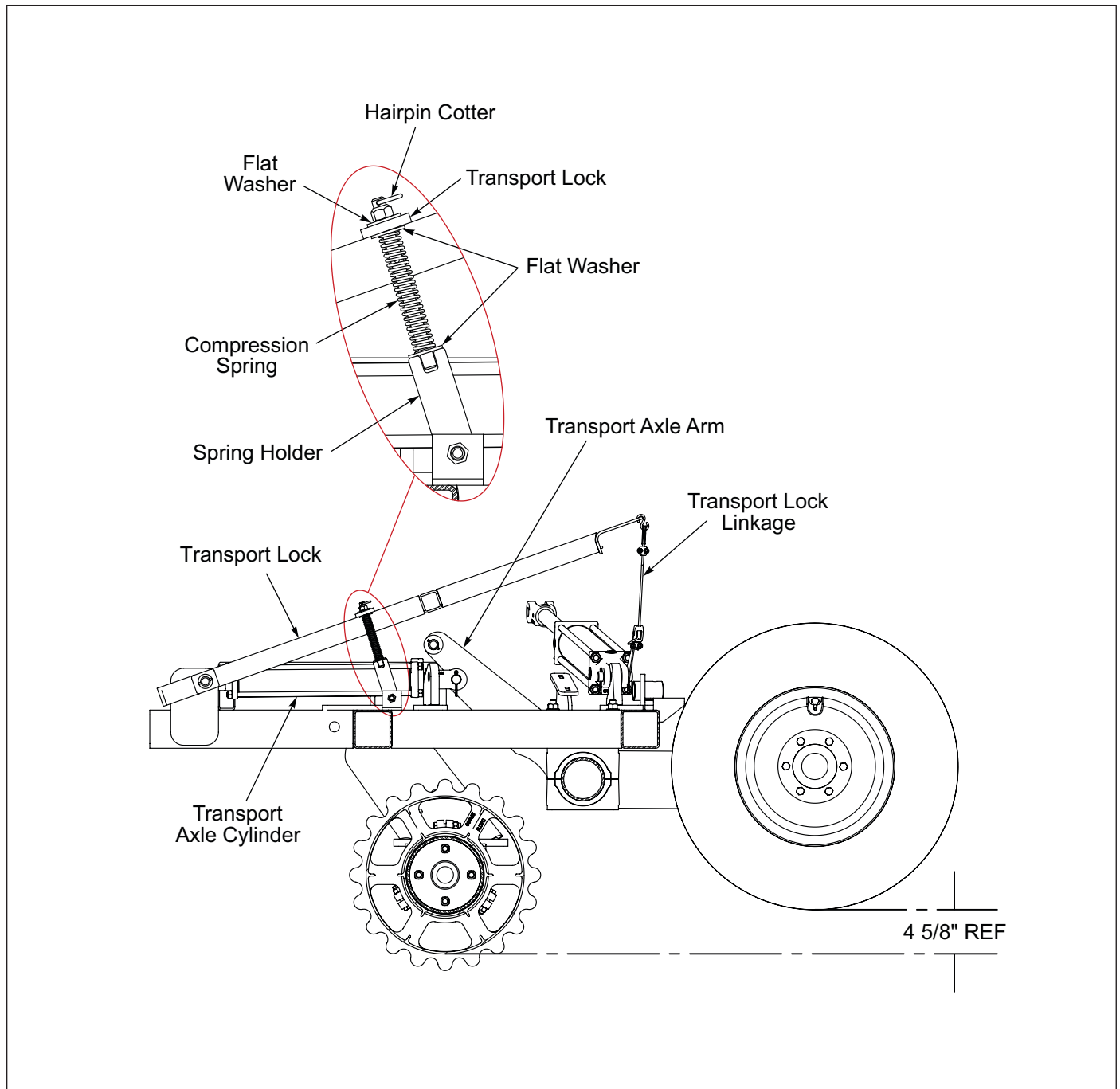

**Figure 3-4: Transport Lock - Locked Position**



**Road to Field**

1. Remove the Transport Lock Hairpin Cotters from the bottom hole of the Spring Holder and insert it into the top hole. **See Figure 3-5.**
  2. Actuate the tractor hydraulic lever to unfold wings completely, slackening the cable/spring linkage.
  3. Reverse tractor hydraulic lever to extend the Lift Cylinder completely allowing the pair of compression springs to push the Transport Lock up and out of the way of the Lift Cylinder.
  4. Reverse the tractor hydraulic level again to retract the Lift Cylinder lowering the machine to the ground. The Tire and Wheel Assemblies should be off the ground approximately 4 inches.
  5. Continue holding the tractor hydraulic lever until the Wing Cylinders are completely extended for field operation.
- During field operation, it is not necessary to raise the machine for turns, but turns should be as wide as possible. Slow down when operating on rocky soil.

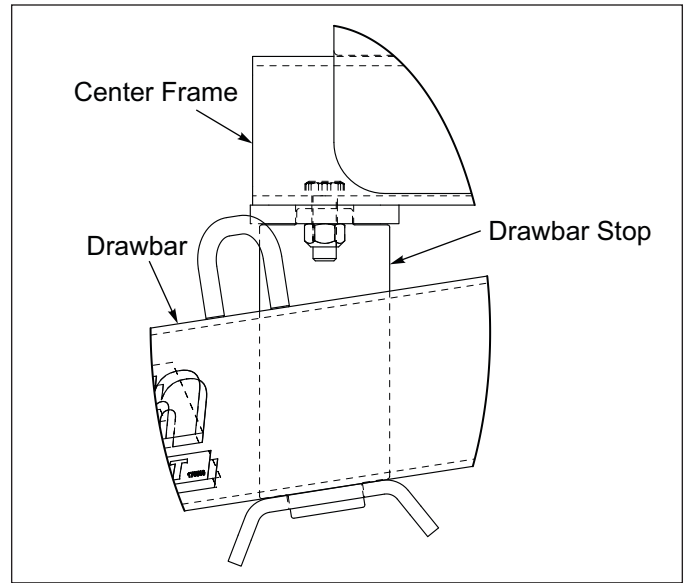

**Figure 3-5: Transport Lock - Unlocked Position**

# Drawbar Adjustment

The Pulverizer drawbar can pivot vertically in field operation to limit soil pushing.

1. Place shims on top of the brace if the center roller pushes soil and place shims under the brace if wing rollers push soil. The placement of shims must be identical on both sides of Pulverizer. **See Figure 3-7.**
2. Ensure the Drawbar Stop is installed. **See Figure 3-6.** *The Drawbar Stop limits the drawbar vertical travel.*



**Figure 3-6: Drawbar Stop**

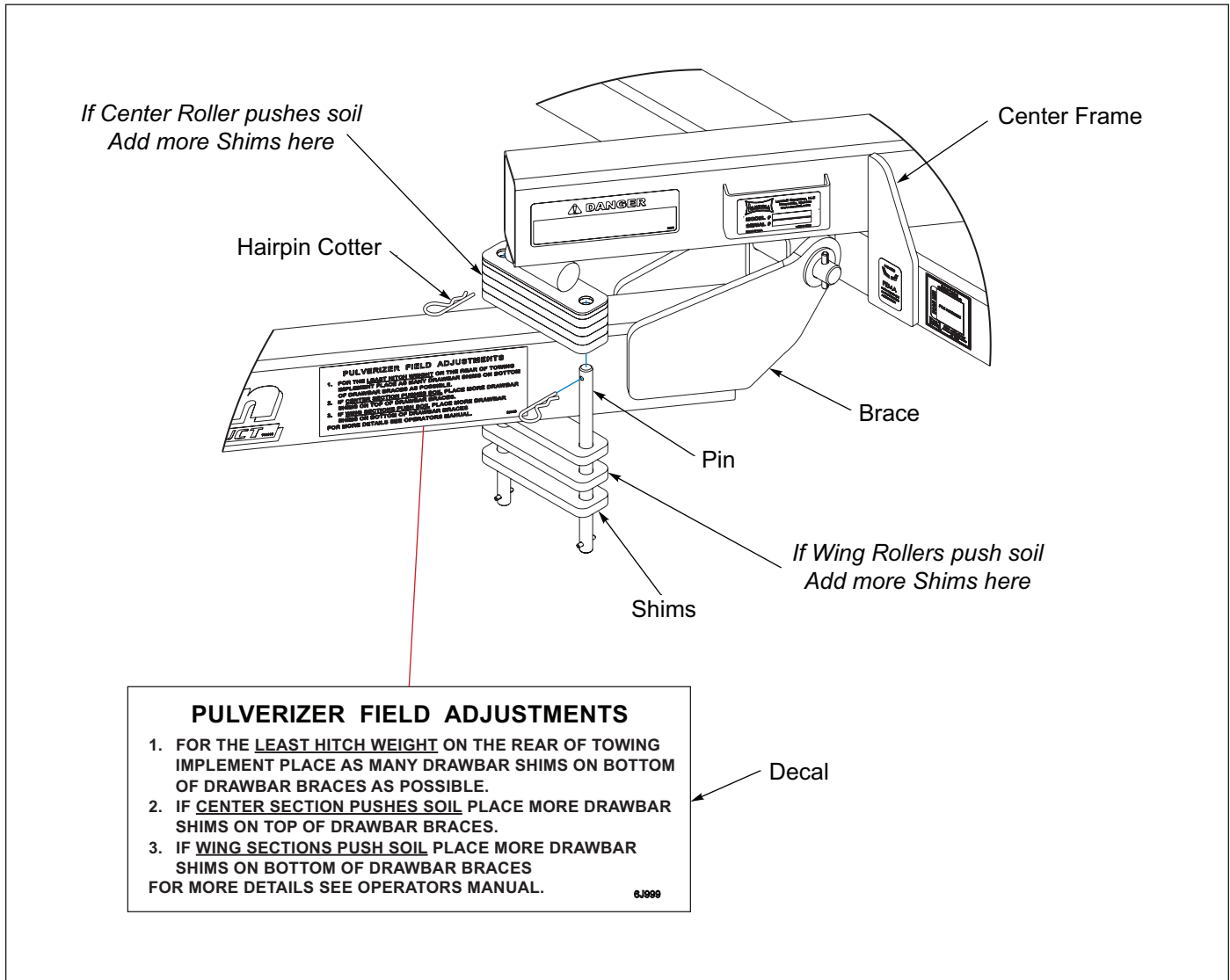

**Figure 3-7: Drawbar Adjust**

# Scraper Adjustment

Notched Roller Wheel Scrapers are designed to keep the Notched Roller Wheels from building up with moist soil during operation. Adjustment of the Scrapers will be necessary as the Roller Wheels and/or the Scrapers wear.

**NOTE**

*Notched and Heavy Notched Roller Wheel Scrapers are optional and reversible. Adjustment procedure is the same.*

**NOTE**

*A scraper can be used as a guide to achieve the 1/4" gap.*

1. Unfold and Lower Pulverizer on a level surface.
2. Push Notched Wheels against welded Roller Axle End Stops. Add Clamp End Spacers if needed. See "Clamp End Spacers - Optional" on page 4-8.
3. Adjust Scrapers as needed to obtain a 1/4" gap between the Scraper and Notched Wheels. See Figure 3-8.

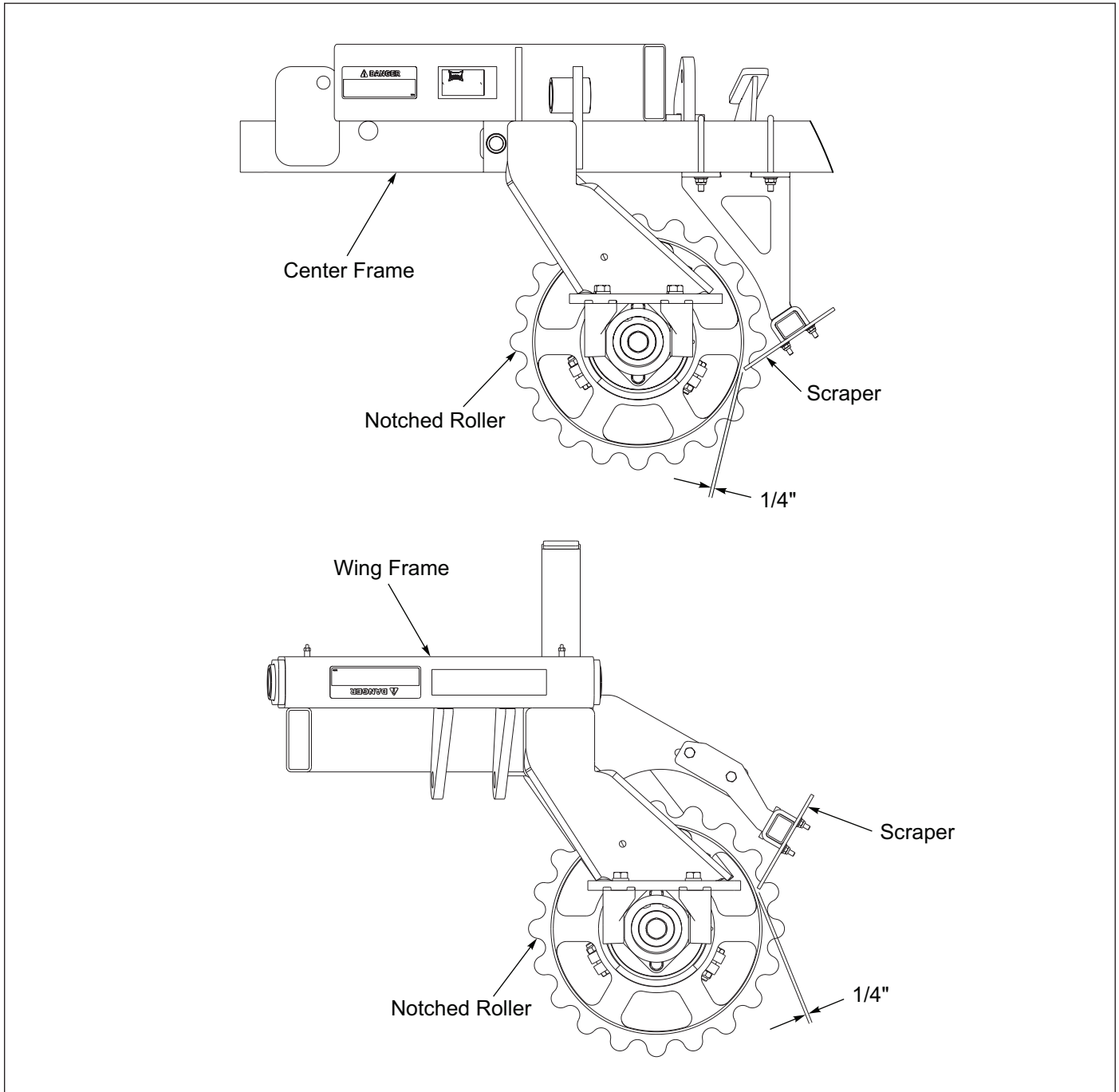

**Figure 3-8: Scraper Adjustment**

# Loup Acre Meter Kit - Optional

**IMPORTANT**

**Acre Meter is dust and splash resistant, under no circumstances should this unit be submerged in any conductive, corrosive, or flammable liquid. At no time use high pressure water or air to clean it, as this can damage the unit.**

## Settings for Loup Acre Meters

The battery operated Acre Meter operates in one of two modes.

1. In sleep mode, the display is blank and the counter is accumulating acres. Sleep mode will be entered if a button is not pressed for 20 seconds.
2. In entry mode, the display is on, and the operator can enter values. To get into entry mode, press the **\*/FUNC** button. If you continue to press the **\*/FUNC** button, the acre counter will cycle through the functions that it can perform. The LEDs above the display indicate which function is selected.

**The available functions are:** Field Acres, Total Acres, Pulses per 400 feet, Width, Password and Low Battery. **See Figure 3-9.**

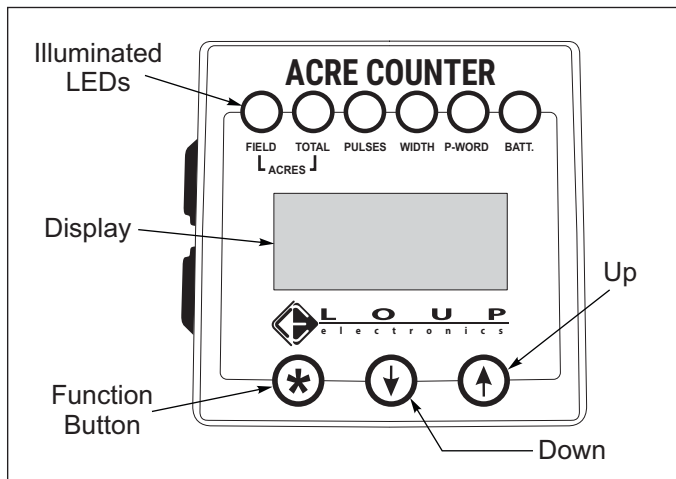

**Figure 3-9: Acre Meter**

## Field Acres

Press the **\*/FUNC** button until the “**FIELD**” LED is lit. The digits indicate the acres covered since the field acre counter was cleared.

To clear the field acre count, press the **UP** and **DOWN** buttons simultaneously for two seconds. If a password has been entered, you will not be able to clear the total acre count. Field acres will count in tenths of an acre up to 9999.9 acres.

## Total Acres

Press the **\*/FUNC** button until the “**TOTAL**” LED is lit. The digits indicate the acres covered since the total acre counter was cleared.

To clear the total acre count, press and hold the **UP** and **DOWN** buttons for two seconds. If a password has been entered, you will not be able to clear the total acre count. Total acres will count from .1 to 99999 acres.

## Pulses Per 400 Feet

Press the **\*/FUNC** button until the “**PULSES**” LED is lit. The number in the display indicates how many pulses are generated for every 400 feet driven. There are two methods to enter the pulses per 400 feet:

1. If you know the number, select it using the **UP** and **DOWN** buttons. When you press the **\*/FUNC** button, the Acre Counter will accept the number in the display as the new pulses per 400 feet. **See Table 3-2.**
2. If you do not know the pulses per 400 feet, press and hold the **UP** and **DOWN** buttons until the “0” appears in the display. The “**PULSES**” LED will blink. The acre counter is now counting shaft rotations. Enter the cab, lower seeder, engage clutch if equipped, and drive 400 feet. Press the **\*/FUNC** button to wake up the acre counter. The “**PULSES**” LED will light. The number displayed is the pulses per 400 feet. Press the **\*/FUNC** button to accept the setting.

If a password is set, you will not be able to adjust the pulses.

## Width

Press the **\*/FUNC** button until the “**WIDTH**” LED is lit. The number displayed is the length of your machine in feet.

To adjust the width, press the **UP** and **DOWN** buttons. If a password has been entered, you will not be able to adjust the width.

The width can be adjusted from .1 to 99.9 feet, in tenths of a foot.

## Password

The password function allows you to protect the total acre count, pulses per 400 feet, and width settings with a password. This stops anyone from accidentally changing those settings. When the acre counter is shipped, the password is disabled. You can modify the pulses per 400 feet and machine width at any time.

Press the **\*/FUNC** button until the “**PASS**” LED is lit. The digits will display the word “**Ent**” or “**dis**”.

**If the display shows “dis”.** The password is disabled. The total acre count, pulses/400 feet, width, and password settings can be adjusted using the **UP** and **DOWN** buttons. The password can also be changed using the **UP** and **DOWN** buttons.

If the display shows “Ent”: You must enter your password using the **UP** and **DOWN** buttons. When your password is displayed, press the **\*/FUNC** button to test the password. If the password is correct, you will be able to change the acre counter settings. The password will be viewable until the acre counter enters sleep mode. When the acre counter is in entry mode again, you will have to re-enter the password to change settings.

If the password is not correct, you will not be able to change the acre counter settings. When the “PASS” function is selected again, “Ent” will appear in the display.

**Changing the Password**

Select a new password using the **UP** and **DOWN** buttons. Press the **\*/FUNC** button until the word “SET” appears in the display. Release the **\*/FUNC** button. The number in the display is your new pass code. Make sure you record this number. Press and hold the **\*/FUNC** button until the word “dis” appears in the display.

If the password is forgotten, it can be disabled by removing the batteries. The password is intended for rental units. It is recommended that a seal be affixed to the rear plate of the acre counter to determine if the settings have been tampered with.

**Battery Replacement**

The battery operated acre counter uses 3 AA batteries. The “BATT” LED will light when the batteries require replacement. Remove the acre counter from the machine and undo the 4 screws on the back of the case. See **Figure 3-10**. This will separate the housing from the rear plate. Replace the batteries with 3 high quality AA alkaline batteries.

See “Acre Meter Troubleshooting” on Page 4-10.

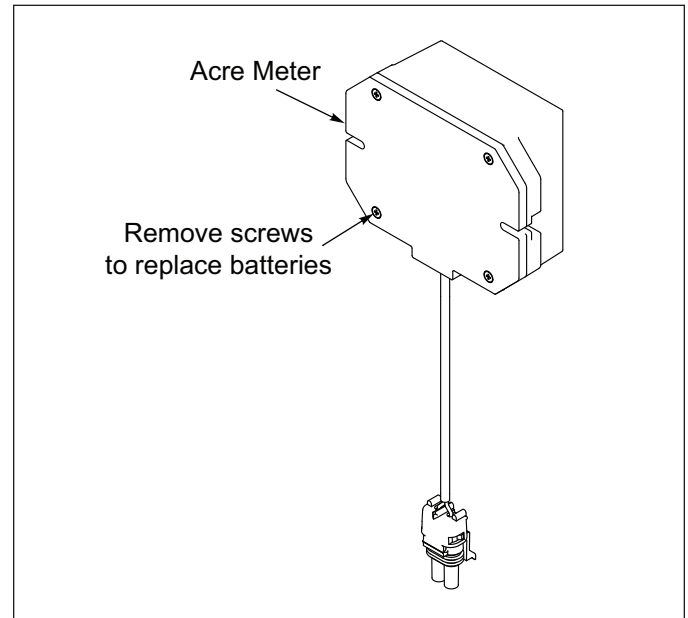

**Figure 3-10: Battery Replacement**

Wheel Type		Pulses
2P800	Notched Ductile	90

**Table 3-2: Acre Meter Settings**

**OPERATION**

# Transport

1. Check and follow all federal, state, and local requirements before transporting the Pulverizer.
2. The Pulverizer should be transported only by tractor required for field operation. The implement weight should not exceed more than 1.5 times the tractor weight. Maximum transport speed for the Pulverizer is 20 mph for the implement.

**! CAUTION**

**Excessive speed may result in loss of control of the tractor and implement, reduced braking ability, or failure of the implement tire or structure. Do not exceed the implement maximum specified ground speed regardless of the capability of the maximum tractor speed.**

3. When towing equipment in combination, the maximum equipment ground speed shall be limited to the lowest specified ground speed of any of the towed implements.

Maximum transport speed shall be the lesser of travel speed specified in the operator's manual, speed identification symbol, information sign of towed equipment, or limit of road conditions.

4. Slow down when driving on rough roads. Reduce speed when turning, or on curves and slopes to avoid tipping. Equipment altered other than the place of manufacture may reduce the maximum transport speed. Additional weight, added tanks, harrowing attachments, etc. may reduce implement load carrying capabilities.
5. A Safety Chain is provided with the implement to insure safe transport. **See Figure 1-2.**
  - The Safety Chain should have a tensile strength equal to or greater than the gross weight of the implement. The chain is attached to the lower hitch clevis hole with two flat washers between the clamp plates to assure a tight connection. Always use a 1" diameter Grade 8 bolt for this connection.
  - Attach the Safety Chain to the tractor drawbar. Provide only enough slack in the chain for turning. Do not use an intermediate chain support as the attaching point for the chain on the tractor. Do not pull the implement by the Safety Chain.
  - Regularly inspect the Safety Chain for worn, stretched, or broken links and ends. Replace the Safety Chain if it is damaged or deformed in any way.

6. Before transporting:
  - Know the transport height and width of the unit before transporting. Use caution when transporting near bridges and power lines.

**! DANGER**

**Stay away from power lines when transporting, extending implement. Electrocutation can occur without direct contact.**

- Clean all Hydraulic Couplings and attach to tractor remotes.
- Connect the Safety Warning Lights 7-Pin Plug into the tractor 7-Pin outlet, routing cord by avoiding pinch points.
- Raise the machine to full transport height.
- Make sure Transport Lock is installed and secure with Hair Pin Cotter. **See "Operation of Transport Lock" on page 3-4.**

**! WARNING**

**Failure to use transport lock during transport may result in permanent equipment damage, serious injury, or death.**

- Check all tires for proper inflation, and that wheel bolts or lug nuts are properly torque.
- Verify that all warning lights, SMV sign, reflectors, and safety decals are clearly visible and functioning properly.
- Transport during daylight hours whenever possible. Always use flashing warning lights, except where such use is prohibited by law. Make sure lights, reflectors and SMV emblem are clearly visible and operating. Remove any obstructions such as dirt, mud, stalks or residue that restricts view before transporting. **See Figure 3-11.**

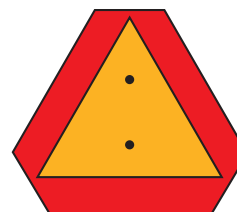

**Figure 3-11: SMV Sign**

## General Torque Specifications

(rev. 4/97)

This chart provides tightening torques for general purpose applications when special torques are not specified on process or drawing. Assembly torques apply to plated nuts and capscrews assembled without supplemental lubrication (as received condition). They do not apply if special graphite moly-disulfide or other extreme pressure lubricants are used. When fasteners are dry (solvent cleaned) add 33% (as received condition) torque. Bolt head identification marks indicate grade and may vary from manufacturer to manufacturer. Thick nuts must be used on grade 8 capscrews. Use value in [ ] if using prevailing torque nuts.

### TORQUE SPECIFIED IN FOOT POUNDS

UNC SIZE	SAE Grade 2	SAE Grade 5	SAE Grade 8	UNF SIZE	SAE Grade 2	SAE Grade 5	SAE Grade 8
1/4-20	4 [5]	6 [7]	9 [11]	1/4-28	5 [6]	7 [9]	10 [12]
5/16-18	8 [10]	13 [13]	18 [22]	5/16-24	9 [11]	14 [17]	20 [25]
3/8-16	15 [19]	23 [29]	35 [42]	3/8-24	17 [21]	25 [31]	35 [44]
7/16-14	24 [30]	35 [43]	55 [62]	7/16-20	27 [34]	40 [50]	60 [75]
1/2-13	35 [43]	55 [62]	80 [100]	1/2-20	40 [50]	65 [81]	90 [112]
9/16-12	55 [62]	80 [100]	110 [137]	9/16-18	60 [75]	90 [112]	130 [162]
5/8-11	75 [94]	110 [137]	170 [212]	5/8-18	85 [106]	130 [162]	180 [225]
3/4-10	130 [162]	200 [250]	280 [350]	3/4-16	150 [188]	220 [275]	320 [400]
7/8-9	125 [156]	320 [400]	460 [575]	7/8-14	140 [175]	360 [450]	500 [625]
1-8	190 [237]	408 [506]	680 [850]	1-14	210 [263]	540 [675]	760 [950]
1-1/8-7	270 [337]	600 [750]	960 [1200]	1-1/8-12	300 [375]	660 [825]	1080 [1350]
1-1/4-7	380 [475]	840 [1050]	1426 [1782]	1-1/4-12	420 [525]	920 [1150]	1500 [1875]
1-3/8-6	490 [612]	1010 [1375]	1780 [2225]	1-3/8-12	560 [700]	1260 [1575]	2010 [2512]
1-1/2-6	650 [812]	1460 [1825]	2360 [2950]	1-1/2-12	730 [912]	1640 [2050]	2660 [3325]

### METRIC:

Coarse thread metric class 10.9 fasteners and class 10.0 nuts and through hardened flat washers, phosphate coated, Rockwell "C" 38-45. Use value in [ ] if using prevailing torque nuts.

Nominal Thread Diameter (mm)	Newton Meters (Standard Torque)	Foot Pounds (Standard Torque)	Nominal Thread Diameter (mm)	Newton Meters (Standard Torque)	Foot Pounds (Standard Torque)
6	10 [14]	7 [10]	20	385 [450]	290 [335]
7	16 [22]	12 [16]	24	670 [775]	500 [625]
8	23 [32]	17 [24]	27	980 [1105]	730 [825]
10	46 [60]	34 [47]	30	1330 [1470]	990 [1090]
12	80 [125]	60 [75]	33	1790 [1950]	1340 [1450]
14	125 [155]	90 [115]	36	2325 [2515]	1730 [1870]
16	200 [240]	150 [180]	39	3010 [3210]	2240 [2380]
18	275 [330]	205 [245]			

# Hydraulic Fitting Torque Specifications

## 37 degree JIC, ORS, & ORB (REV. 10/97)

This chart provides tightening torques for general purpose applications when special torques are not specified on process or drawing. Assembly torques apply to plated nuts and capscrews assembled without supplemental lubrication (as received condition). They do not apply if special graphite moly-disulfide or other extreme pressure lubricants are used. When fasteners are dry (solvent cleaned) add 33% to (as received condition) torque. Bolt head identification marks indicate grade and may vary from manufacturer to manufacturer. Thick nuts must be used on grade 8 capscrews. Use value in [ ] if using prevailing torque nuts.

### TORQUE SPECIFIED IN FOOT POUNDS

<b>PARKER® BRAND FITTINGS</b>			
Dash Size	37 Deg. JIC	O-Ring (ORS)	O-Ring boss
-4	11-13	15-17	13-15
-5	14-16	-----	21-23
-6	20-22	34-36	25-29
-8	43-47	58-62	40-44
-10	55-65	100-110	58-62
-12	80-90	134-146	75-85
-16	115-125	202-218	109-121
-20	160-180	248-272	213-237
-24	185-215	303-327	238-262
-32	250-290	-----	310-340

<b>AEROQUIP® BRAND FITTINGS</b>			
Dash Size	37 Deg. JIC	O-Ring (ORS)	O-Ring boss
-4	11-12	10-12	14-16
-5	15-16	-----	16-20
-6	18-20	18-20	24-26
-8	38-42	32-35	50-60
-10	57-62	46-50	75-80
-12	79-87	65-70	125-135
-14	-----	-----	160-180
-16	108-113	92-100	200-220
-20	127-133	125-140	210-280
-24	158-167	150-165	270-360

<b>GATES® BRAND FITTINGS</b>			
Dash Size	37 Deg. JIC	O-Ring (ORS)	O-Ring boss
-4	10-11	10-12	14-16
-5	13-15	-----	-----
-6	17-19	18-20	24-26
-8	34-38	32-40	37-44
-10	50-56	46-56	50-60
-12	70-78	65-80	75-83
-14	-----	65-80	-----
-16	94-104	92-105	111-125
-20	124-138	125-140	133-152
-24	156-173	150-180	156-184
-32	219-243	-----	-----

## Fasteners

Before operating your Brillion machine, check all hardware for tightness. Use the Tightening Torque Table as a guide. **See Page 4-1.**

After a few hours of use, check entire machine and tighten any loose nuts or bolts. Daily or periodic checks should be made thereafter.

When replacing bolts, be sure to use fasteners of equal grade.



## Tires

**Recommended Tire Size:** 9.52L x 15-8 Ply

**Tire Inflation Pressure:** 44 PSI

When Re-Installing 1/2-20 x 1 Wheel Bolts tighten to 50 Ft-Lbs using the sequence in **Figure 4-1**. Then tighten to full torque of 85-90 Ft-Lbs.

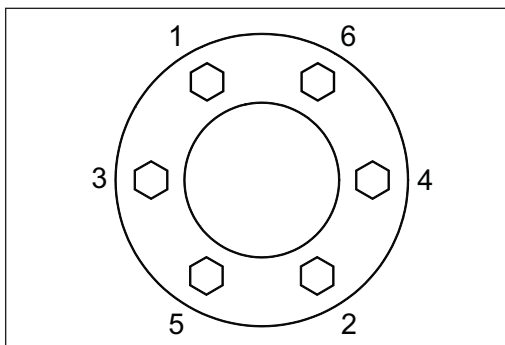

**Figure 4-1: Tightening Sequence**

## Wheel Hub Bearing Maintenance

Wheel Bearing maintenance should be performed at the beginning of every season of use. Check the Wheel Bearings periodically for excessive end play. If needed, adjust or replace them using the following procedure:

1. Place the Frame on blocks or stands sufficient to lift the Tire clear of the ground.
2. Remove the Tire.
3. Remove the Hub Cap, Cotter Pin, Slotted Nut, and Washer.
4. Remove the Hub. Clean and inspect the Bearings and Hub Cavity. Replace any worn or defective parts.
5. Repack the Bearings using a high-quality Wheel Bearing Grease.
6. Install the Inner Bearing into the hub and install the grease seal. Use a driver to install the seal, to avoid damaging the outer edge of the seal. Drive the seal squarely into the hub to avoid any seal distortion.

### NOTE

*The Double Lip Seals should point away from the Hub to keep contaminants out and allow grease to pass.*

7. Slide the hub, bearing, and seal onto a clean spindle.
8. Install the Outer Bearing Cone, Washer, and Slotted Nut.
9. Tighten the Slotted Nut while rotating the Hub until there is a slight resistance to wheel rotation. Then, back the Slotted Nut off one notch, until the wheel rotates freely without end play.
10. Install a new Cotter Pin and re-install the Hub Cap.

## Lubrication Maintenance

- Lubricate Trunnion Bearings and Hinge Pins with quality grease every 20 hrs or if machine is not used for an extended period. Greasable components are the same on each side. **See Figure 4-2.**

### CAUTION

**Over lubrication of these bearings can cause premature bearing failure.**

- Grease Wheels Hubs every 50 hrs. Repack Wheel Hub Bearing annually before each season usage.
- When the machine is not used for some time, exposed portions of the Hydraulic Cylinder Rods must be cleaned and covered with a thick coat of grease to prevent corrosion, which will damage the seal.

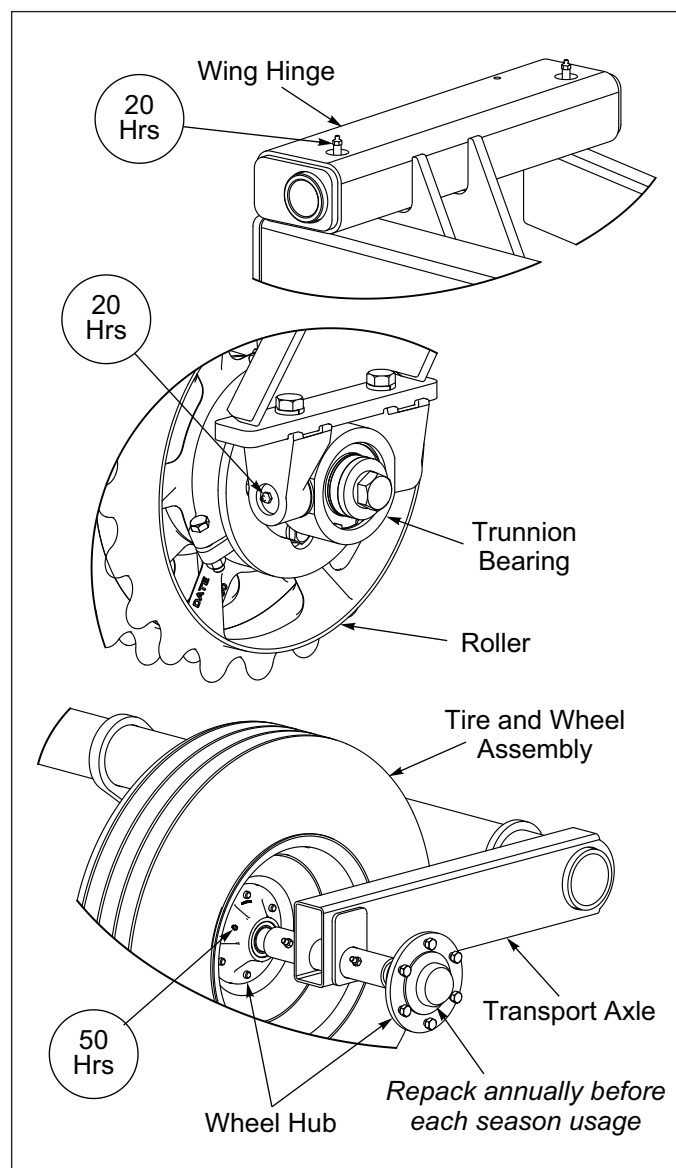

**Figure 4-2: Lubrication Points and Intervals**

# Hydraulic System Maintenance

**IMPORTANT**

Unfold, lower the unit to the ground, and relieve hydraulic pressure before attempting to service any hydraulic component.

**NOTE**

Never unfold the wings past center until all air is out of the hydraulic circuit, as free-falling may occur.

 **WARNING**

Escaping fluid under pressure can be nearly invisible and have enough force to penetrate the skin causing serious injury. Relieve system pressure before repairing, adjusting, or disconnecting. Use a piece of cardboard, rather than your hands, to search for suspected leaks. See Figure 4-3. Wear protective gloves & safety glasses or goggles when working with hydraulic systems. Keep all components (cylinders, hoses, fittings, etc.) in good repair.

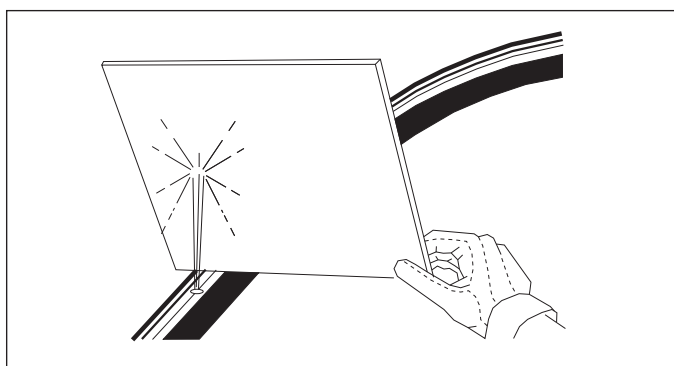

**Figure 4-3: Hydraulic Leak Detection**

1. Check the tractor hydraulic fluid level per tractor owner's manual and after any leakage. Check fluid level with the machine unfolded, Fold Cylinders extended and Lift Cylinder retracted.
2. If a Hydraulic Cylinder leaks, disassemble the parts to determine the cause of the leak. Any time a Hydraulic Cylinder is opened up, or whenever any Seal replacement is necessary, it is advisable to clean all parts and replace all Seals. Seal Kits are available from your Brillion dealer.
3. Check all Hydraulic Hoses weekly. Look for binding or cracking. Replace all worn or defective parts immediately.
4. Transport Locks are provided to hold the implement in a raised position. **See Figure 3-4.** Do not attempt to perform any service work under the implement

without first installing the Transport Locks. Before servicing any hydraulic component, lower the implement to the ground and relieve all system pressure. If a hydraulic component is disconnected, repaired, or replaced, it will be necessary to purge the system of air before operation. **See "Purging the Hydraulic System" on Page 2-14.**

**The sequence for the hydraulic circuit is as follows:**

**Field to Road:**

- Actuate the tractor hydraulic lever to raise the center and fold the Wings for transport.
- The Transport Lock automatically engages the lift system.
- Remove the Transport Lock Hairpin Cotters from the top hole of the Spring Holder and insert it into the bottom hole locking the Transport Lock in place. **See Figure 3-4.**
- If the Transport Lock fails to pull down completely and lock in position, adjust the Transport Lock Linkage chain length by repositioning the S-Hook on the chain.

**Road to Field:**

- Remove the Transport Lock Hairpin Cotters from the bottom hole of the Spring Holder and insert it into the top hole. **See Figure 3-5.**
- Actuate the tractor hydraulic lever to completely unfold the Wings.
- Reverse the tractor hydraulic lever extending the Lift Cylinder to release the Transport Lock.
- Reverse the tractor hydraulic lever again to retract the Lift Cylinder lowering the machine to the ground. The Tire and Wheel Assemblies are off the ground approximately 4 inches.
- Continue holding the tractor hydraulic lever until the Wing Cylinders are completely extended for field operation.

## Purging Hydraulic System after repairs

**Wings Folded**

If repairs were made with wings folded, cycle fold cylinders, but limit travel to keep weight of wing pushing on cylinder. Cycle minimum of 5 times.

**Wings Unfolded**

If repairs were made with wings unfolded, remove pins from each Fold Cylinder Rod End Clevis. Block cylinders up and cycle cylinders minimum of 5 times to purge air from system.

Do not loosen any hoses or fittings. Recheck tractor reservoir to make sure it is within operating limits.

## Warning Lamps

When plugging in the 7-Pin Connector:

1. Make sure the tractor has a good clean receptacle, free of dirt and corrosion.
2. Make sure the 7-Pin Connector is inserted ALL the way in. With tighter fitting pins, operator may think the connector is all the way in, but really isn't.
3. Make sure the tractor receptacle cover latches over the keyway on the 7-Pin Connector to hold the connector in place.

If an operator plugs in the 7-Pin Connector, but the lights do not seem to work right, check the above items to make sure there is a good connection with the 7-Pin Connector.

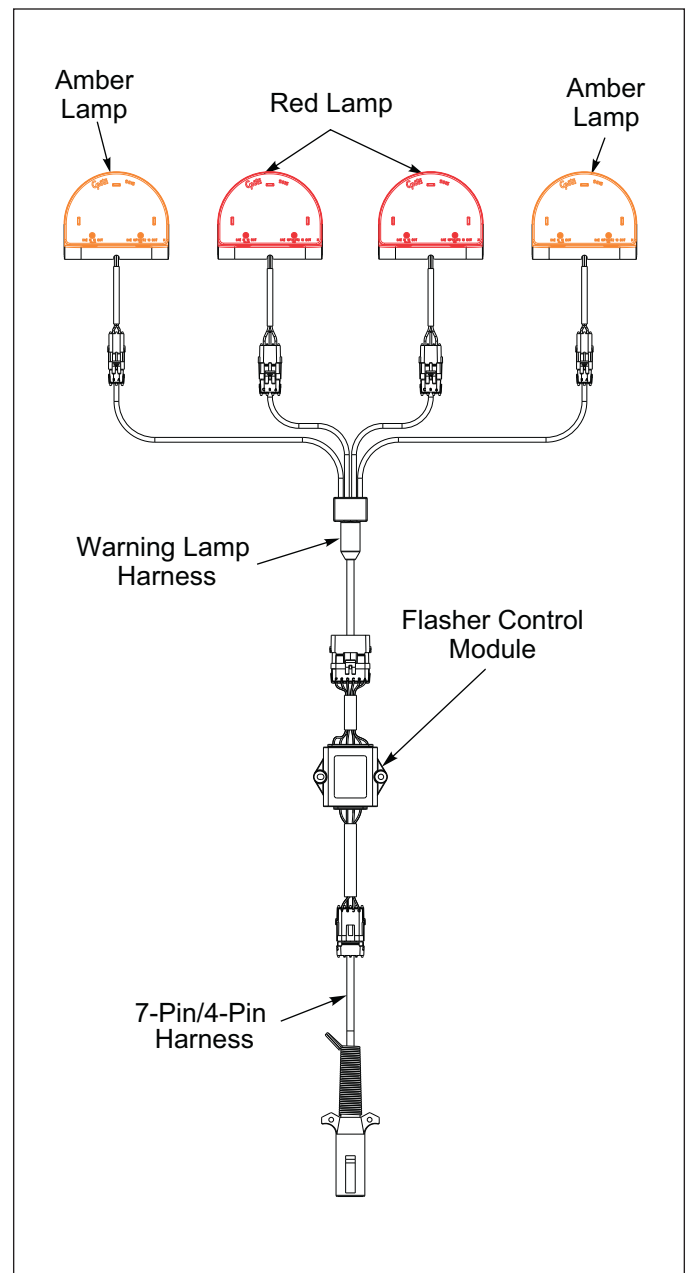

Figure 4-4: Warning Lamps

# Roller Bearing Maintenance

If bearings are removed from frame refer to the steps below to ensure minimum axle load is applied to prolong bearing life.

1. With the Bearing Grease Fitting facing towards the rear or upward of the machine, slide the Trunnion Bearing Mounts onto the Trunnion Bearings and lift the Roller Assembly up to the Center Frame Bearing Hangers. Hand tighten 3/4-10 hardware to hold Trunnion Bearing Mounts in place.
2. Look at each Trunnion Bearing Mount to make sure that it is sitting perpendicular to the Center Frame Bearing Hanger. If not adjust the Shim Washers accordingly, for each side there are two 11ga and one 14ga Shim Washers. Shim Washers can be all three

on the inside between the Stub Shaft shoulder and the Trunnion Bearing, all three can be on the outside between the Trunnion Bearing and Flat Top Washer, or a combination on either side, but all three must be used to minimize the gap. If gap cannot be properly minimized with bearing snap rings to outside, turn bearing around to have snap ring to inside. The bearing inner race is offset with respect to the trunnion bosses by 1/32". By installing bearings with snap rings in versus out, 1/16" difference can be made up at assembly if needed. **See Figure 4-5.**

3. Tighten 3/4-10 and 1-8 hardware to specification per torque chart. **See Page 4-1.**

**NOTE**

*Wheel Stop is on the Clamp side of the Roller Assembly.*

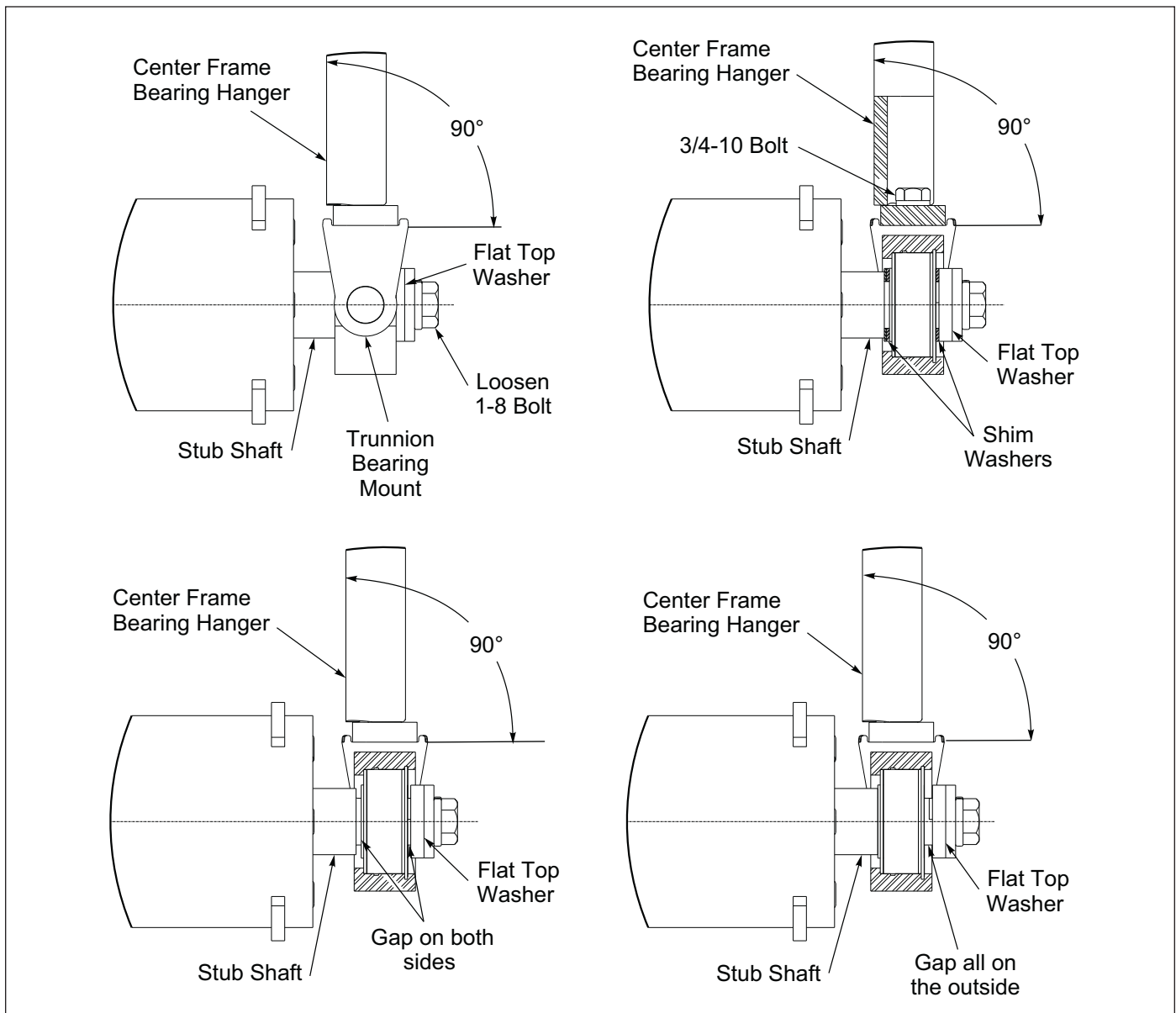

**Figure 4-5: Trunnion Spacing**

## Roller Axle Assembly

After an initial run of 5-10 hours, check the Roller Axle Assemblies to ensure that the wheels are tight to one another. If not, starting at the welded stop end, slide the wheels tight together and adjust the Axle Clamps so that it's against the wheel. **See Figure 4-6.** If there is a gap between the Axle Clamp and Wheel Stop, install the appropriate clamp spacers. **See Figures 4-9 and 4-10.**

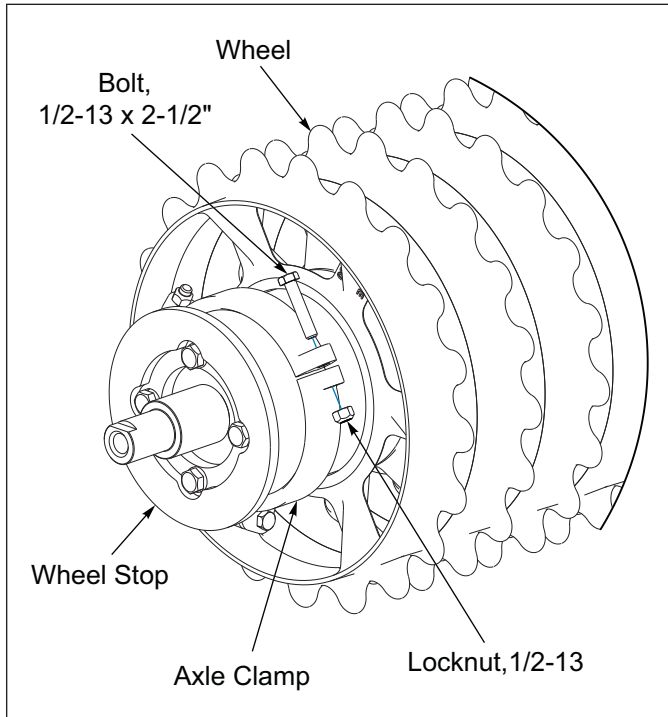

**Figure 4-6: Roller Axle Assembly**

## Clamp Tightening

### Standard Wheel Roller

1. Tighten the Clamp Bolts evenly to achieve equal spacing between clamp section. Torque to 75 Ft-Lbs. **See Figure 4-7.**
2. Check assemblies every 50-100 hours.

### V-Style Ductile Iron Wheel Roller

1. Check Axle and Clamp for burrs on mating surfaces.
2. Remove end play between wheels by sliding wheels toward the fixed end of the Axle.
3. Position Clamp snugly against the End Wheel.
4. Tighten the U-Bolt evenly to 57 Ft-Lbs. **See Figure 4-8.**
5. Check assemblies every 50-100 hours.

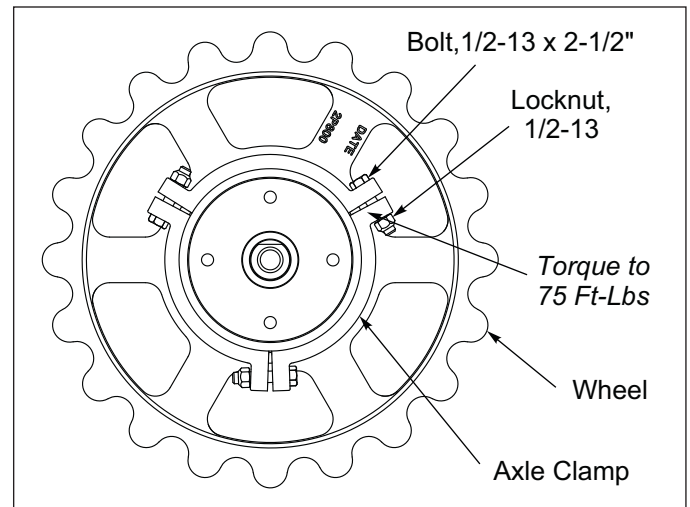

**Figure 4-7: Clamp Tightening**

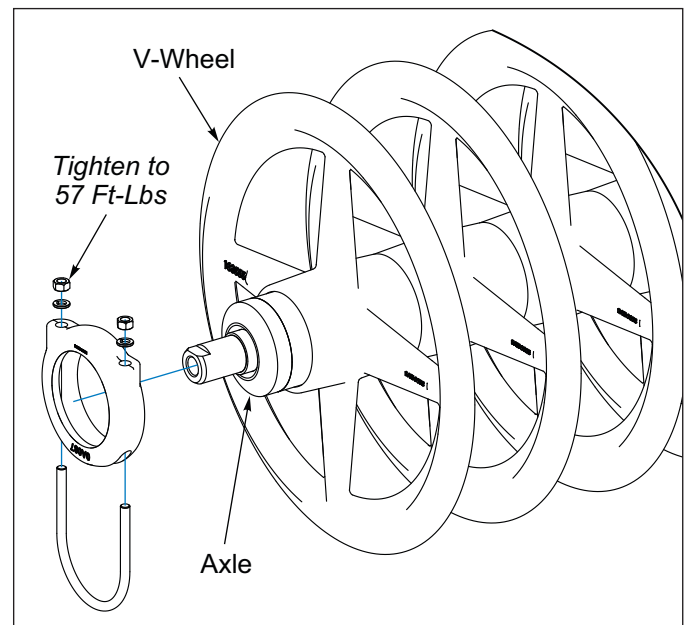

**Figure 4-8: V-Wheel Clamp Tightening**

# Clamp End Spacers - Optional

The Clamp End Spacer Kits are used to eliminate space between the Axle Clamp and the Wheel Stop.

**IMPORTANT**

Unfold and lower machine prior to performing any steps.

Kit Part Number 201442 - 3/4" Axle Spacer

Kit Part Number 201443 - 1/2" Axle Spacer

Installation is the same for either kit.

1. Place the two Axle Spacers between the Axle Clamp and the Wheel Stop. **See Figure 4-9.**
2. Insert two 3/8-16 x 1-3/4 Bolts through the Axle Spacers and secure with 3/8-16 Locknuts.

Refer to the Torque Table for proper bolt torque values. Note the different torque requirement for Bolts with Locknuts. **See Page 4-1.**

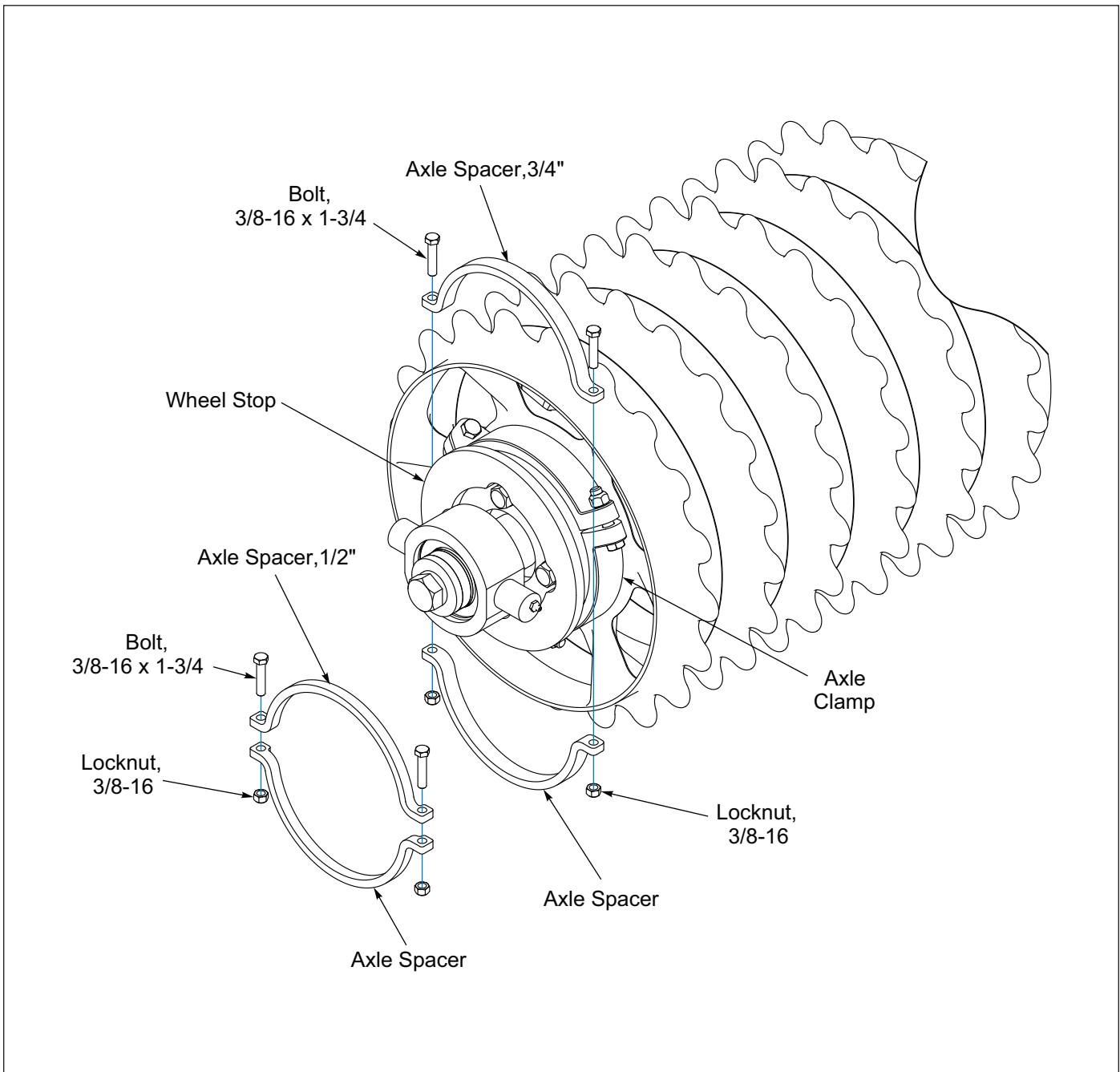

**Figure 4-9: Clamp End Spacer Kit, 1/2", 3/4" - Optional**

**Kit Part Number 204831 - 1" Axle Spacer**

**Kit Part Number 204832 - 1-1/4" Axle Spacer**

**Kit Part Number 204833 - 1-1/2" Axle Spacer**

Refer to the Torque Table for proper bolt torque values. Note the different torque requirement for Bolts with Locknuts. **See Page 4-1.**

1. Place the two Axle Spacers between the Axle Clamp and the Wheel Stop. **See Figure 4-10.**
2. Insert two 3/8-16 x 1 Bolts through the Axle Spacers and secure with 3/8-16 Locknuts.

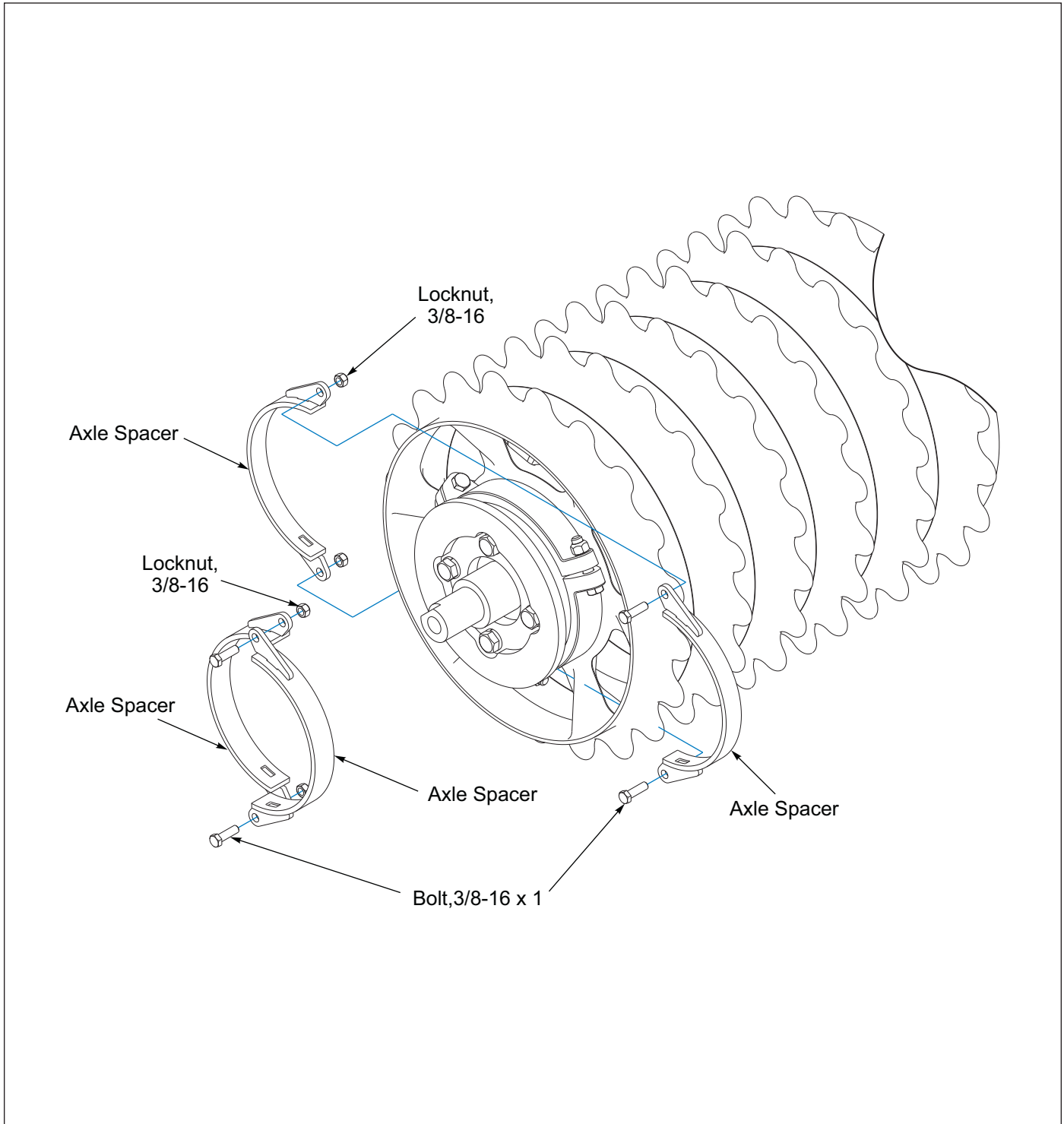

**Figure 4-10: Clamp End Spacer Kit , 1" , 1-1/4" , 1-1/2" - Optional**

## Acre Meter Troubleshooting

### IMPORTANT

Acre Meter is dust and splash resistant, under no circumstances should this unit be submerged in any conductive, corrosive, or flammable liquid. At no time use high pressure water or air to clean it, as this can damage the unit. See Figure 4-11.



Figure 4-11: High Pressure Warning

### NOTE

The ground wire is for static discharge protection and has no effect on the ability of the sensor to function properly under normal conditions.

The battery operated Acre Meter uses 3 AA batteries. The Acre Meter will display “LOBat” when the batteries require replacement. Remove the Acre Meter from the machine and then the 4 Screws on the back of the case. See Figure 4-12. Separate the housing from the rear plate. Replace with 3 quality AA batteries.

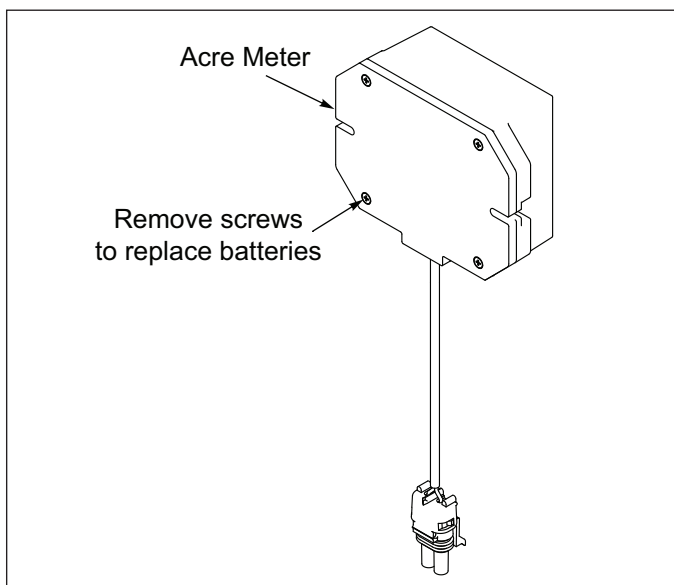

Figure 4-12: Battery Replacement

**Acre Meter does not count pulses during calibration or does not count acres during operation.**

1. Check the position of the Magnet Wheel Assembly and Pick-Up Switch against the set-up instructions in this manual. See “Acre Meter - Optional” on Page 2-26.

2. Verify that the magnet in the Magnet Wheel Assembly has not come out.
3. Place the Acre Meter display in “Calibrate” mode by pressing the \*(FUNC) key until the “P-Word” indicator is lit and then press the up/down arrow keys until the display shows 0 and the LED is blinking. Break the connection between the display and the Pick-Up Switch and short between pins A and B on the display harness connector. You should see the display increment +1 with each contact of the connector terminals.
4. If Step 3 works then wave a magnet in front of the Pick-Up Switch face with it re-connected to the display and see if the display increments up. If not, put an ohm meter or continuity tester on the contacts of the Pick-Up Switch harness and place a magnet in front of the Pick-Up Switch face. The Pick-Up Switch should show continuity or near zero ohms resistance.

**Acre Meter cannot change the width or pulse count settings or clear the field and total acres.**

1. Check to see if a password needs to be entered by pressing the \*(FUNC) key until the “P-Word” indicator LED is lit. If “dis” is displayed (password disabled) no password is set.
2. If “Ent” is displayed a password must be entered to change the settings or the password must be disabled as instructed in the setup section of this manual.

## Storage

1. The service life of the Pulverizer will be extended by proper off-season storage practices. Prior to storing the unit, complete the following procedures:
  - Completely clean the unit.
  - Inspect the machine for worn or defective parts. Replace as needed.
  - Repaint all areas where the original paint is worn off.
  - Apply a light coating of oil or grease to exposed Cylinder Rods to prevent them from rusting.
  - Lubricate the machine as stated in “Lubrication Maintenance” on Page 4-3.
2. Store the unit in a shed or under a tarpaulin to protect it from the weather. The ground engaging components and Tires should rest on boards, or some other object, to keep them out of the soil.
3. If the unit is stored in the folded position, make sure the Transport Lock is installed to prevent settling. See “Operation of Transport Lock” on Page 3-4.
4. Relieve Hydraulic Pressure in hoses after Transport Lock is installed.
5. Block wheels before unhitching from tractor.



Specifications

Product Attributes	X20	X22
<b>Approximate Weight</b>		
(XDS) 20" Notched Ductile Iron Wheels with Scrapers	5,246 lbs. (2,380 kg)	5,509 lbs. (2,499 kg)
(XD) 20" Notched Ductile Iron Wheels Excluding Scrapers	5,023 lbs. (2,278 kg)	5,271 lbs. (2,391 kg)
(XO) 20" Optimizer Ductile Iron Wheels	5,445 lbs. (2,470 kg)	5,744 lbs. (2,605 kg)
(XC) 20" Crowfoot Ductile Iron Wheels	4,470 lbs. (2,028 kg)	4,966 lbs. (2,253 kg)
(XHS) 20" Notched Ductile Iron H (Heavy) Wheels with Scrapers	5,937 lbs. (2,693 kg)	6,267 lbs. (2,843 kg)
(XH) 20" Notched Ductile Iron H (Heavy) Wheels Excluding Scrapers	5,718 lbs. (2,594 kg)	6,034 lbs. (2,737 kg)
(XHR) 20" Notched Ductile Iron H (Heavy) Wheels with Sprockets	6,627 lbs. (3,006 kg)	7,035 lbs. (3,191 kg)
(XVS) 22" V-Style Ductile Iron Wheels with Scrapers	5,682 lbs. (2,577 kg)	6,020 lbs. (2,731 kg)
(XV) 22" V-Style Ductile Iron Wheels Excluding Scrapers	5,248 lbs. (2,380 kg)	5,528 lbs. (2,507 kg)
<b>Approximate Tongue Weight</b>		
<b>Drawbar, Transport</b>	598 lbs. (271 kg)	603 lbs. (274 kg)
<b>Operation</b>	Under 500 lbs. (227 kg)	Under 500 lbs. (227 kg)
<b>Working Width</b>	20 ft. 1 in. (6.1 m)	22 ft. 1 in. (6.7 m)
<b>Transport Width</b>	11 ft. (3.4 m)	11 ft. (3.4 m)
<b>Transport Height</b>	7 ft. 3 in. (2.2 m)	7 ft. 6 in. (2.3 m)
<b>Overall Length</b>	22 ft. 2 in. (6.8 m)	22 ft. 6 in. (6.9 m)
<b>Road Clearance</b>		
XDS, XD, XO, XC, XHS, XH, XHR Models	11.625 in. (295 mm)	11.625 in. (295 mm)
XVS, XV Models	10.625 in. (270 mm)	10.625 in. (270 mm)
<b>Mechanical Transport Lock</b>	Standard	Standard
<b>Hydraulic Circuits Required</b>	1	1
<b>Number of Pulverizer Wheels</b>		
(XDS) 20" Notched Ductile Iron Wheels with Scrapers	62	68
(XD) 20" Notched Ductile Iron Wheels Excluding Scrapers	62	68
(XO) 20" Optimizer Ductile Iron Wheels	40	44
(XC) 20" Crowfoot Ductile Iron Wheels	40	44
(XHS) 20" Notched Ductile Iron H (Heavy) Wheels with Scrapers	62	68
(XH) 20" Notched Ductile Iron H (Heavy) Wheels Excluding Scrapers	62	68
(XHR) 20" Notched Ductile Iron H (Heavy) Wheels with Sprockets	62	68
(XVS) 22" V-Style Ductile Iron Wheels with Scrapers (6" Spacing)	40	44
(XV) 22" V-Style Ductile Iron Wheels Excluding Scrapers (6" Spacing)	40	44
<b>Axle Size</b>		
XDS, XD, XO, XC, XHS, XH, XHR Models	8 in. (203 mm)	8 in. (203 mm)
XVS, XV Models	4.5 in. (114 mm)	4.5 in. (114 mm)
<b>Hitch</b>	Pull-Type with Hydraulic Transport	Pull-Type with Hydraulic Transport
<b>Tire Size</b>	9.5L x 15-8 Ply Tires on 6 Bolt Rims	9.5L x 15-8 Ply Tires on 6 Bolt Rims
<b>Scraper Kits</b>	Standard on 'S' Models	Standard on 'S' Models
<b>Weight Kit</b>	Optional	Optional
<b>Electronic Acre Meter</b>	Optional	Optional
<b>LED Safety Warning Lights &amp; SMV Emblem</b>	Standard	Standard
<b>Safety Chain Kit</b>	Standard	Standard
<b>Powder Coat Paint, Red</b>	Standard	Standard
<b>Horsepower Requirements</b>	3 to 5 HP per ft. (2.2 to 3.7 kW per m)	3 to 5 HP per ft. (2.2 to 3.7 kW per m)
<b>Horsepower Requirements As Companion Tool</b>	1 to 3 HP per ft. (0.75 to 2.2 kW per m)	1 to 3 HP per ft. (0.75 to 2.2 kW per m)
<b>Recommended Operating Speed</b>	3 to 8 MPH (4.8 to 12.9 km/h)	3 to 8 MPH (4.8 to 12.9 km/h)

Specifications subject to change with or without notice.

Figure 5-1: Models Specifications (1 of 2)

## TABLE OF CONTENTS

### SPECIFICATIONS

Product Attributes	X24	X26
<b>Approximate Weight</b>		
(XDS) 20" Notched Ductile Iron Wheels with Scrapers	5,792 lbs. (2,627 kg)	6,053 lbs. (2,746 kg)
(XD) 20" Notched Ductile Iron Wheels Excluding Scrapers	5,519 lbs. (2,503 kg)	5,766 lbs. (2,615 kg)
(XO) 20" Optimizer Ductile Iron Wheels	6,043 lbs. (2,741 kg)	6,334 lbs. (2,873 kg)
(XC) 20" Crowfoot Ductile Iron Wheels	5,192 lbs. (2,355 kg)	5,418 lbs. (2,458 kg)
(XHS) 20" Notched Ductile Iron H (Heavy) Wheels with Scrapers	6,617 lbs. (3,001 kg)	6,947 lbs. (3,151 kg)
(XH) 20" Notched Ductile Iron H (Heavy) Wheels Excluding Scrapers	6,349 lbs. (2,880 kg)	6,664 lbs. (3,023 kg)
(XHR) 20" Notched Ductile Iron H (Heavy) Wheels with Sprockets	7,443 lbs. (3,376 kg)	7,851 lbs. (3,561 kg)
(XVS) 22" V-Style Ductile Iron Wheels with Scrapers	6,336 lbs. (2,874 kg)	6,651 lbs. (3,017 kg)
(XV) 22" V-Style Ductile Iron Wheels Excluding Scrapers	5,807 lbs. (2,634 kg)	6,086 lbs. (2,761 kg)
<b>Approximate Tongue Weight</b>		
<b>Drawbar, Transport</b>	609 lbs. (276 kg)	615 lbs. (279 kg)
<b>Operation</b>	Under 500 lbs. (227 kg)	Under 500 lbs. (227 kg)
<b>Working Width</b>	24 ft. 1 in. (7.3 m)	26 ft. 1 in. (7.9 m)
<b>Transport Width</b>	11 ft. (3.4 m)	11 ft. (3.4 m)
<b>Transport Height</b>	7 ft. 9 in. (2.4 m)	7 ft. 11 in. (2.4 m)
<b>Overall Length</b>	22 ft. 10 in. (7.0 m)	23 ft. 1 in. (7.0 m)
<b>Road Clearance</b>		
XDS, XD, XO, XC, XHS, XH, XHR Models	11.625 in. (295 mm)	11.625 in. (295 mm)
XVS, XV Models	10.625 in. (270 mm)	10.625 in. (270 mm)
<b>Mechanical Transport Lock</b>	Standard	Standard
<b>Hydraulic Circuits Required</b>	1	1
<b>Number of Pulverizer Wheels</b>		
(XDS) 20" Notched Ductile Iron Wheels with Scrapers	74	80
(XD) 20" Notched Ductile Iron Wheels Excluding Scrapers	74	80
(XO) 20" Optimizer Ductile Iron Wheels	48	52
(XC) 20" Crowfoot Ductile Iron Wheels	48	52
(XHS) 20" Notched Ductile Iron H (Heavy) Wheels with Scrapers	74	80
(XH) 20" Notched Ductile Iron H (Heavy) Wheels Excluding Scrapers	74	80
(XHR) 20" Notched Ductile Iron H (Heavy) Wheels with Sprockets	74	80
(XVS) 22" V-Style Ductile Iron Wheels with Scrapers (6" Spacing)	48	52
(XV) 22" V-Style Ductile Iron Wheels Excluding Scrapers (6" Spacing)	48	52
<b>Axle Size</b>		
XDS, XD, XO, XC, XHS, XH, XHR Models	8 in. (203 mm)	8 in. (203 mm)
XVS, XV Models	4.5 in. (114 mm)	4.5 in. (114 mm)
<b>Hitch</b>	Pull-Type with Hydraulic Transport	Pull-Type with Hydraulic Transport
<b>Tire Size</b>	9.5L x 15-8 Ply Tires on 6 Bolt Rims	9.5L x 15-8 Ply Tires on 6 Bolt Rims
<b>Scraper Kits</b>	Standard on 'S' Models	Standard on 'S' Models
<b>Weight Kit</b>	Optional	Optional
<b>Electronic Acre Meter</b>	Optional	Optional
<b>LED Safety Warning Lights &amp; SMV Emblem</b>	Standard	Standard
<b>Safety Chain Kit</b>	Standard	Standard
<b>Powder Coat Paint, Red</b>	Standard	Standard
<b>Horsepower Requirements</b>	3 to 5 HP per ft. (2.2 to 3.7 kW per m)	3 to 5 HP per ft. (2.2 to 3.7 kW per m)
<b>Horsepower Requirements As Companion Tool</b>	1 to 3 HP per ft. (0.75 to 2.2 kW per m)	1 to 3 HP per ft. (0.75 to 2.2 kW per m)
<b>Recommended Operating Speed</b>	3 to 8 MPH (4.8 to 12.9 km/h)	3 to 8 MPH (4.8 to 12.9 km/h)

*Specifications subject to change with or without notice.*

**Figure 5-2: Models Specifications (2 of 2)**

# Document Control Revision Log:

Date	Form #	Improvement(s): Description and Comments
03/2015	R0	Initial Release
09/2017	R1	Updated Model Sizes Updated ISO logos to ISO 9001:2015 (Revised 04/2024)
06/2024	F-788-2406	Revised Template ECN 49750 - Added Decals: QR Code, Fema, 20 mph



**intertek**

Equipment from Landoll Company, LLC is built to exacting standards ensured by ISO 9001:2015 registration at all Landoll manufacturing facilities.

# **X Pulverizer Models X20-26 Parts Manual**

## **Re-Order Part Number F-788**

**LANDOLL COMPANY, LLC**

1900 North Street

Marysville, Kansas 66508

(785) 562-5381

**800-428-5655 ~ WWW.LANDOLL.COM**



Copyright 2024. Landoll Company, LLC

“All rights reserved, including the right to reproduce this material or portions thereof in any form.”

