

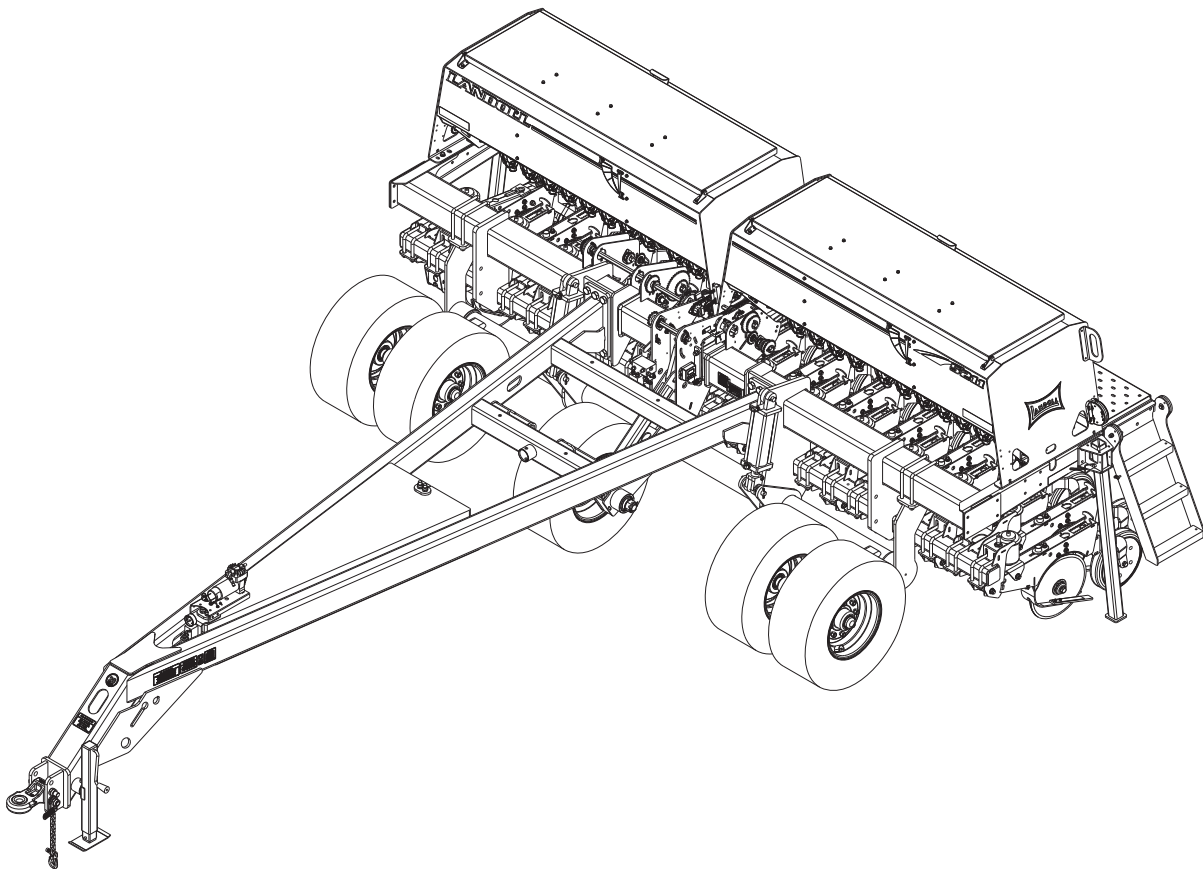

**Model 5211**  
**Grain Drill**  
**Operator's Manual**



**LANDOLL COMPANY, LLC**

1900 North Street

Marysville, Kansas 66508

(785) 562-5381

800-428-5655 ~ [WWW.LANDOLL.COM](http://WWW.LANDOLL.COM)

# Instructions for Ordering Parts

**\*\* Repair parts must be ordered through an Authorized Dealer \*\***

## DEALER INSTRUCTIONS FOR ORDERING PARTS FROM LANDOLL PARTS DISTRIBUTION CENTER

Phone #: 800-423-4320 or 785-562-5381

Fax #: 888-527-3909

Order online: [dealer.landoll.com](http://dealer.landoll.com)

### SERIAL NUMBER PLATE

The Serial Number Plate, which lists the model number and serial number, is located on the front of the frame.

### SERIAL NUMBER NOMENCLATURE

The following information will help decode the 5211 Grain Drill serial number

**52H2022100 = xxmysssss**

### QR CODE DECAL

The 5000 series QR code decal, may be scanned to link you to the most current manuals, located on the front of the frame *See Figure 1-1*

<b>ms</b>	= model series (i.e. 52 for Grain Drill, Rigid)
<b>m</b>	= month of manufacture (ex. "H" means October. The letter I is not used.)
<b>yy</b>	= year manufactured (ex. "22" means 2022)
<b>SSSSS</b>	= Sequential number used to track warranty and service information.

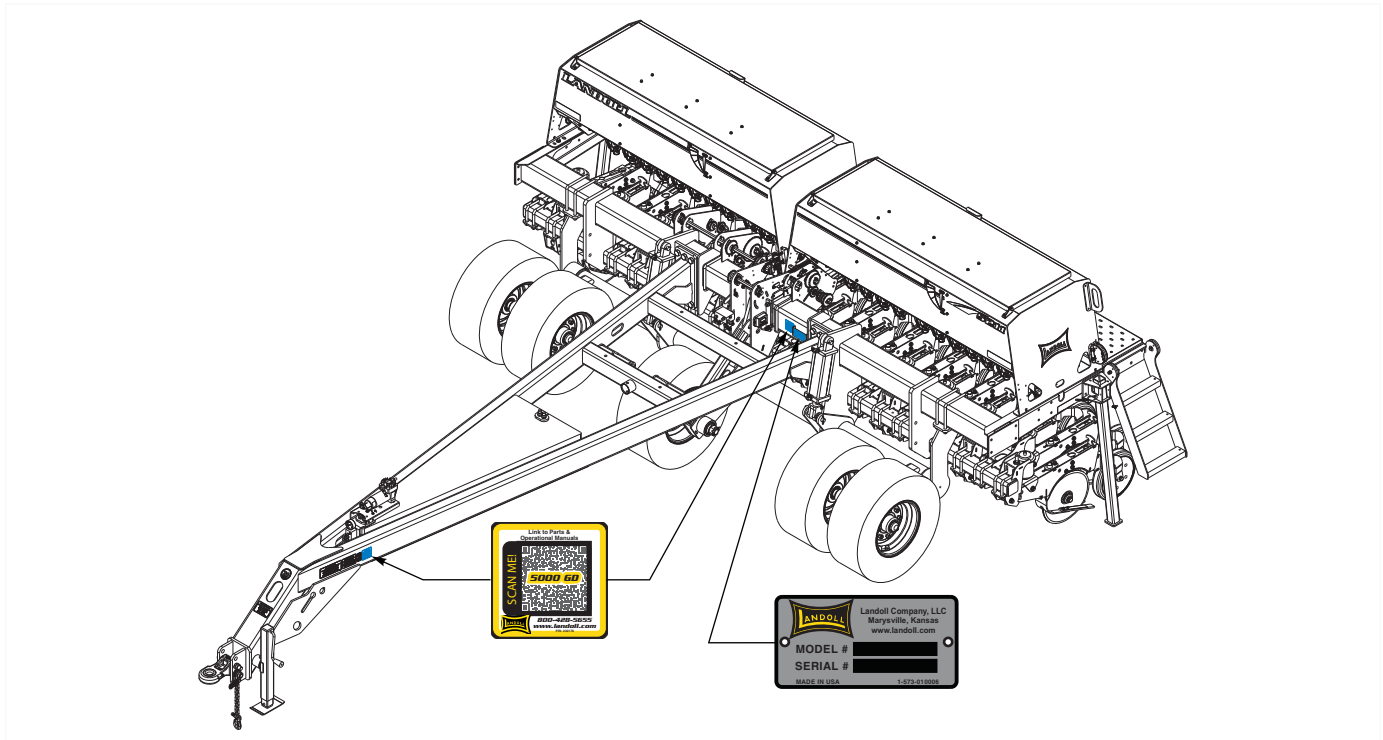

**Figure 1-1: Serial Number Plate and Location**

## Manuals for 5211 Grain Drill

Manual Number	Manual Type
F-725	Operator's Manual
F-726	Parts Manual



# **DANGER**

**DO NOT operate or perform any maintenance tasks on this equipment until you have completed the following:**

- 1. Receive proper training to operate this equipment safely.**
- 2. Read and understand the operator's manual.**
- 3. Be thoroughly trained on inspection and repair procedures.**

**Failure to comply with this warning may result in serious injury or possibly death.**



# Table of Contents

---

## 1 Introduction and Safety Information

Understanding Safety Statements . . . . .	1-2
Transporting Safety . . . . .	1-3
Attaching, Detaching, and Storage . . . . .	1-3
Maintenance Safety . . . . .	1-3
High Pressure Fluid Safety . . . . .	1-3
Protective Equipment . . . . .	1-3
Chemical Safety . . . . .	1-3
Prepare for Emergencies . . . . .	1-4
Tire Safety . . . . .	1-4
Safety Chain . . . . .	1-4
Safety Decals and Reflectors . . . . .	1-5

## 2 Specifications

Introduction . . . . .	2-1
Owner Assistance . . . . .	2-1
Warranty Registration . . . . .	2-1
Model Specifications . . . . .	2-4
General Torque Specifications . . . . .	2-7
Hydraulic Fitting Torque Specifications . . . . .	2-8
5211-10' Opener/Drive/Marker Placement . . . . .	2-9
5211-12-1/2' Opener/Drive/Marker Placement . . . . .	2-12
5211-15' Opener/Drive/Marker Placement . . . . .	2-15
5211-20' Opener/Drive/Marker Placement . . . . .	2-18

## 3 Assembly Instructions

Assembly Safety . . . . .	3-1
Rebounder Assembly . . . . .	3-2
Press Wheel Assembly . . . . .	3-3
Small Seed Attachment Installation (Option) . . . . .	3-4
Agitator Assembly (Option) . . . . .	3-8
5211 Hydraulic Marker Installation (Optional) . . . . .	3-12

## 4 Operation

5211 Operation Checklist . . . . .	4-2
Initial Checklist . . . . .	4-2
Field Checklist . . . . .	4-2
Field Operation . . . . .	4-3
Planting Completion . . . . .	4-3
Tractor Preparation . . . . .	4-4
Grain Drill Preparation . . . . .	4-4
Attaching Grain Drill To The Tractor . . . . .	4-4
Lockouts - Pull Hitch . . . . .	4-5
Leveling the Hitch Clevis . . . . .	4-6
Transporting the Grain Drill . . . . .	4-6

Compressor Operation - Air Opener . . . . .	4-8
Air System Pressure . . . . .	4-8
Hydraulic Lift System - Pull Hitch . . . . .	4-9
Seed Meter Gate Adjustment . . . . .	4-10
Seed Rate Adjustment . . . . .	4-11
Meter/Seed Rate Handle Adjustment . . . . .	4-12
Seed Rate Calibration . . . . .	4-14
Dry Fertilizer Combination Box . . . . .	4-14
Fertilizer Box – Clean Out . . . . .	4-16
Fertilizer – Rate Adjustment . . . . .	4-17
Fertilizer – Rate Calibration . . . . .	4-18
Small Seed Rate Adjustment . . . . .	4-18
Seed Rate Calibration . . . . .	4-20
Small Seed Meter Assembly/Adjustment . . . . .	4-22
Small Seed Disconnect . . . . .	4-23
Air Spring Adjustment . . . . .	4-24
Opener Blade Adjustment . . . . .	4-25
Opener Blade Wear . . . . .	4-25
Opener – Press Wheel Adjustment . . . . .	4-26
Opener Scraper Adjustment . . . . .	4-26
Opener Soil Strip Adjustment . . . . .	4-28
Spring Opener . . . . .	4-29
Walkboard . . . . .	4-30
Ladder Use and Transport Requirements . . . . .	4-31
Hydraulic Row Markers (Option) . . . . .	4-32
Hydraulic Row Marker Disc Adjustment (Option) . . . . .	4-33
Coulter Hitch (Option) . . . . .	4-34
3 Point Hitch (Option) . . . . .	4-35
Loup Mini Drill Monitor Operation (Optional) . . . . .	4-36
Battery Operated Acre Counter Operation (Optional) . . . . .	4-36
Field Acres . . . . .	4-37
Total Acres . . . . .	4-37
Pulses per 400 Feet . . . . .	4-38
Width . . . . .	4-38
Password . . . . .	4-39
Changing the Password . . . . .	4-40
Battery Replacement . . . . .	4-40

## **5 Maintenance and Lubrication**

Wheel Bearing Maintenance – Triple-Lip . . . . .	5-1
Hydraulic Maintenance . . . . .	5-2
Hose Identification . . . . .	5-2
Parking . . . . .	5-2
Lubrication Maintenance . . . . .	5-4
Storage . . . . .	5-6

## **6 Troubleshooting Guide**

# Introduction and Safety Information

---

The Landoll Model 5211 Grain Drill is a quality product designed to give years of trouble free performance. By following each section of this manual, your system will perform as designed for you and your operation.

- CHAPTER 1** Gives basic instructions on the use of this manual and understanding the safety statements.
- CHAPTER 2** Gives product specifications for the equipment. These specifications supply lengths and measures for your equipment. A Standard Bolt Torque Table is provided to give guidelines for bolt torques to be used when servicing this product.
- CHAPTER 3** Contains assembly instructions for your equipment. When these procedures are correctly followed, your equipment should provide you years of trouble-free operation and service.
- CHAPTER 4** Instructs how to operate your equipment before using it, and describes adjustments needed.
- CHAPTER 5** Instructs how to operate your equipment before using it, and describes adjustments needed. Gives practical advice for the care and maintenance of your Landoll equipment. Drawings in this section locate adjustment points on the equipment.

**IF YOU HAVE ANY QUESTIONS CONTACT:**

**LANDOLL COMPANY, LLC  
1900 NORTH STREET  
MARYSVILLE, KANSAS 66508**

**PHONE # (785) 562-5381 or (800) 428-5655  
OR  
FAX # (888) 527-3909**

- CHAPTER 6** Is a troubleshooting guide to aid in diagnosing and solving problems with the equipment.
- PARTS LIST** Is a separate manual showing the various assemblies, subassemblies, and systems. Refer to that manual when ordering Landoll replacement parts. Order parts from your Landoll dealer.
- WARRANTY** The Warranty Registration form is included with the product documents. Fill it out and mail it within 10 days of purchase.  
**NOTE: IMPROPER ASSEMBLY, MODIFICATION, OR MAINTENANCE OF YOUR LANDOLL MACHINE CAN VOID YOUR WARRANTY.**
- COMMENTS** Address comments or questions regarding this publication to:

**LANDOLL COMPANY, LLC  
1900 NORTH STREET  
MARYSVILLE, KANSAS 66508  
ATTENTION: PUBLICATIONS - DEPT. 55**

## Understanding Safety Statements

You will find various types of safety information on the following pages and on the machine signs (decals) attached to the machine. This section explains their meaning.



The Safety Alert Symbol means ATTENTION! YOUR SAFETY IS INVOLVED!

### NOTE

*Means that failure to follow these instructions could cause damage to the equipment or cause it to operate improperly.*

### NOTICE

Special notice - read and thoroughly understand.



### CAUTION

Caution means serious equipment or other property damage can occur if instructions on this label are not properly followed.



### WARNING

Warning means serious injury or death can occur if safety measures or instructions on this label are not properly followed.



### DANGER

Danger means a life-threatening situation exists. Death can occur if safety measures or instructions on this label are not properly followed.

### NOTE

*Make sure you read and understand the information contained in this manual and on the machine signs (decals) before you attempt to operate or maintain this machine.*

The safety statements contained in this manual relate to the operation of the Model 5211 Grain Drill.

1. Examine safety decals and be sure you have the correct safety decals for the implement.
2. Keep these signs clean so they can be observed readily. It is important to keep these decals cleaned more frequently than the implement. Wash with soap and water or a cleaning solution as required.
3. Replace decals that become damaged or lost. Also, be sure that any new implement components installed during repair include decals which are assigned to them by the manufacturer.
4. When applying decals to the implement, be sure to clean the surface to remove any dirt or residue. Where possible, sign placement should protect the sign from abrasion, damage, or obstruction from mud, dirt, oil etc.

## Transporting Safety

### IMPORTANT

It is the responsibility of the owner/operator to comply with all state and local laws.

1. Do not tow an implement that, when fully loaded, weighs more than 1.5 times the weight of the towing vehicle.



### DANGER

- Do not allow anyone to ride on the tractor or implement. Riders could be struck by foreign objects or thrown from the implement.
- Never allow children to operate equipment.
- Keep bystanders away from implement during operation.

2. Carry reflectors or flags to mark the tractor and implement in case of breakdown on the road.
3. Do not transport at speeds over 20 MPH under good conditions. Never travel at a speed which does not allow adequate control of steering and stopping. Reduce speed if towed load is not equipped with brakes.
4. Avoid sudden stops or turns because the weight of the implement may cause the operator to lose control of the tractor.
5. Use caution when towing behind articulated steering tractors; fast or sharp turns may cause the implement to shift sideways.
6. Keep clear of overhead power lines and other obstructions when transporting. Know the transport height and width of your implement.

## Attaching, Detaching, and Storage

1. Do not stand between the tractor and implement when attaching or detaching implement unless both are not moving.
2. Check the tires of the implement so it will not roll when unhitched from the tractor.
3. Store in an area where children normally do not play.

## Maintenance Safety

1. Understand the procedure before doing the work. Use proper tools and equipment.
2. Make sure all moving parts have stopped.
3. Do not make adjustments or lubricate implement while it is in motion.
4. Block the implement so it will not roll when working on or under it to prevent injury.

## High Pressure Fluid Safety

1. Escaping fluid under pressure can be nearly invisible and have enough force to penetrate the skin causing serious injury. Use a piece of cardboard, rather than hands, to search for suspected leaks.
2. Any fluid injected into the skin must be surgically removed within a few hours or gangrene may result.
3. Avoid the hazard by relieving pressure before disconnecting hydraulic lines.

## Protective Equipment

1. Wear protective clothing and equipment.
2. Wear clothing and equipment appropriate for the job. Avoid loose fitting clothing.



3. Because prolonged exposure to loud noise can cause hearing impairment or hearing loss, wear suitable hearing protection, such as earmuffs or earplugs.

## Chemical Safety

1. Agricultural chemicals can be dangerous. Improper use can seriously injure persons, animals, plants, soil and property.
2. Read chemical manufacturer instructions and store or dispose of unused chemicals as specified.
3. Handle chemicals with care and avoid inhaling smoke from any type of chemical fire.
4. Store or dispose of unused chemicals as specified by the chemical manufacturer.

### **Prepare for Emergencies**

1. Keep a First Aid Kit and Fire Extinguisher handy.
2. Keep emergency numbers for doctor, ambulance, hospital, and fire department near the phone.

### **Tire Safety**

1. Tire changing can be dangerous and should be performed by trained personnel using correct tools and equipment.
2. When inflating tires, use a clip-on chuck and extension hose long enough to allow you to stand to one side, not in front of or over the tire assembly. Use a safety cage if available.
3. When removing and installing wheels use wheel-handling equipment adequate for the weight involved.

### **Safety Chain**

1. Use a chain with a strength rating equal to or greater than the gross weight of towed machinery, which is 10,100 pounds minimum in accordance with ASAE S338.2 specifications. If two or more implements are pulled in tandem, a larger chain may be required. Chain capacity must be greater than the TOTAL weight of all towed implements.
2. A second chain should be used between each implement.
3. Attach the chain to the tractor drawbar support or specified anchor location. Allow only enough slack in the chain to permit turning. The distance from hitch pin to attachment point or intermediate support point should not exceed 9 inches.
4. Replace the chain if any links or end fittings are broken, stretched or damaged.
5. Do not use a safety chain for towing.

## Safety Decals and Reflectors

The 5211 grain drill is equipped with all safety signs installed for safe operation.

For you safety:

- Carefully read and follow safety sign directions.
- Keep the safety signs clean and visible.
- Replace damaged, missing, or illegible safety signs.
- Be sure any new equipment or repair parts include safety signs.

New safety signs may be ordered from your Landoll dealer. Refer to this section for parts and proper safety sign placement.

To Install new safety signs:

1. Remove the old damaged safety sign if still present.
2. Clean placement area to remove any dirt or grease.
3. Remove backing from new safety sign.
4. Apply the safety sign starting from one end pressing firmly and working across the safety sign being careful not to create any air bubbles.

P/N 224513

Hose ID Grain Drill



Front of hitch, pull hitch option only

QTY. 1

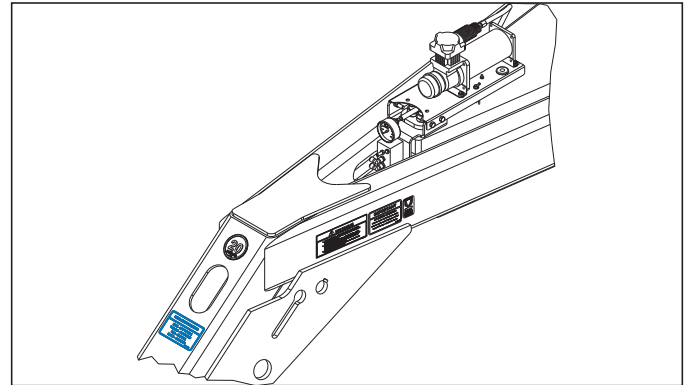

P/N 8-573-010084

Warning: Before Operating



Front of hitch, pull hitch option

QTY. 1

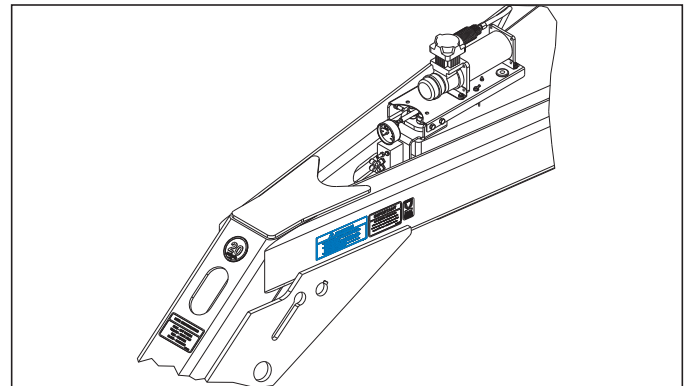

P/N 8-573-010084

Warning: Before Operating



Front of frame, 3-point option

QTY. 1

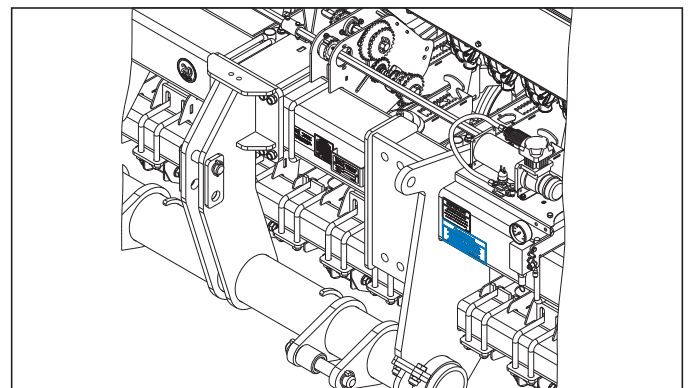

**P/N 144193**

SIS 20MPH



Front of hitch, pull hitch option  
QTY. 1

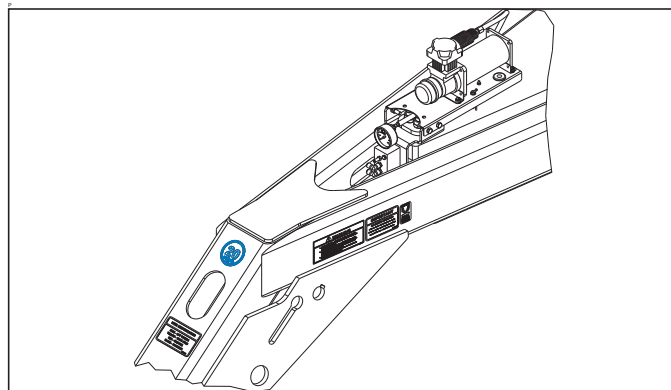

**P/N 144193**

SIS 20MPH



Front of frame, 3-point option  
QTY. 1

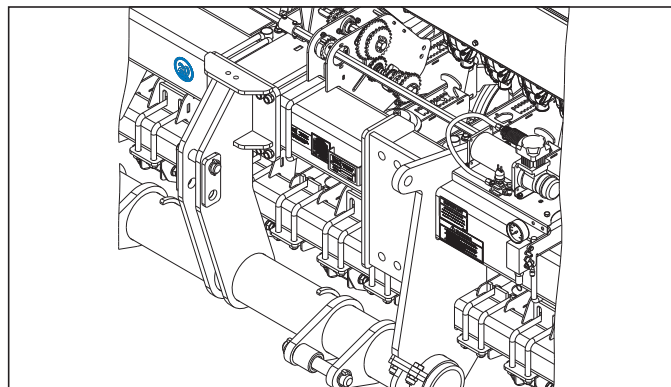

**P/N 211045**

**Important: Air System Operation**

<b>IMPORTANT</b>
<p><b>AIR SYSTEM OPERATION</b></p> <p>Minimum system operating pressure 15 psi.</p> <p>Maximum system operating pressure 100 psi.</p> <p>Keep air filter clean, replace each season.</p> <p style="text-align: right;">211045</p>

Front of hitch, pull hitch option  
QTY. 1

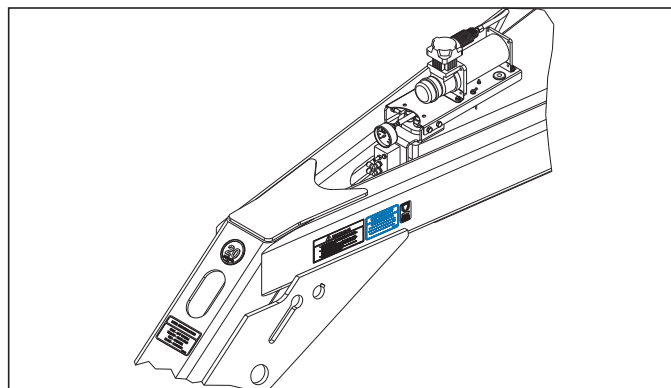

**P/N 211045**

**Important: Air System Operation**

<b>IMPORTANT</b>
<p><b>AIR SYSTEM OPERATION</b></p> <p>Minimum system operating pressure 15 psi.</p> <p>Maximum system operating pressure 100 psi.</p> <p>Keep air filter clean, replace each season.</p> <p style="text-align: right;">211045</p>

Front of frame, 3-point option  
QTY. 1

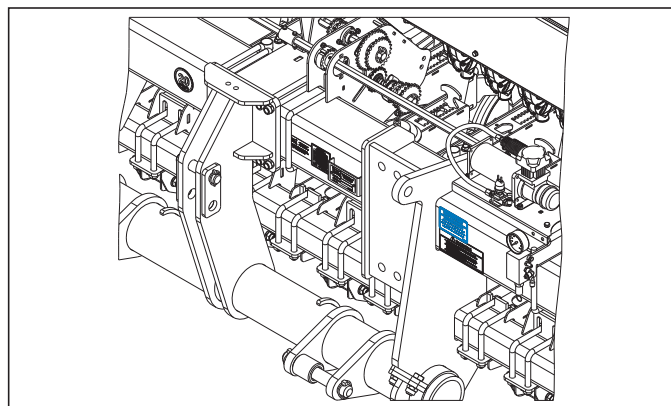

**P/N 528934  
Yellow Reflector**



Front of box, both sides

**QTY. 2**

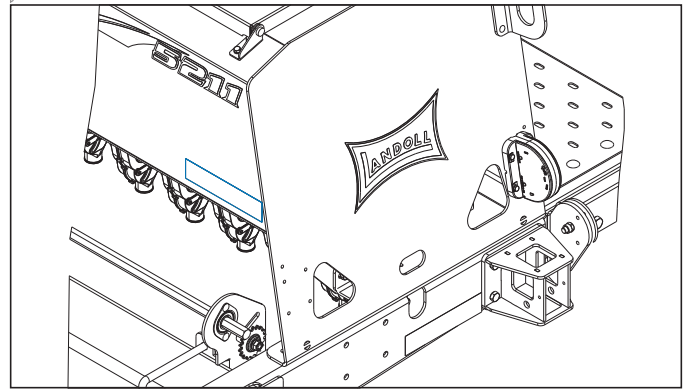

**P/N 528934  
Yellow Reflector**



End of frame, both ends

**QTY. 2**

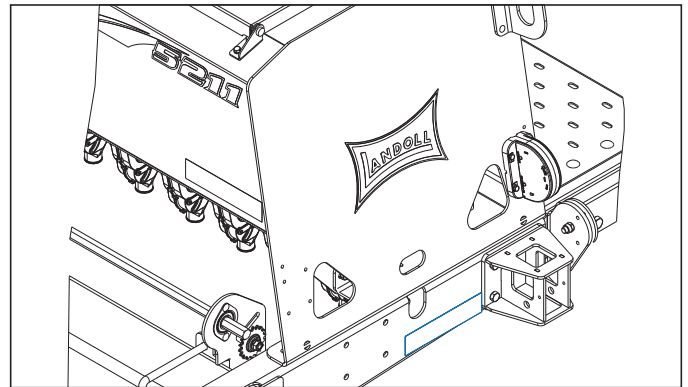

**P/N 528933  
Red Reflector**



Outer ends of rear side of box, bottom

**QTY. 2**

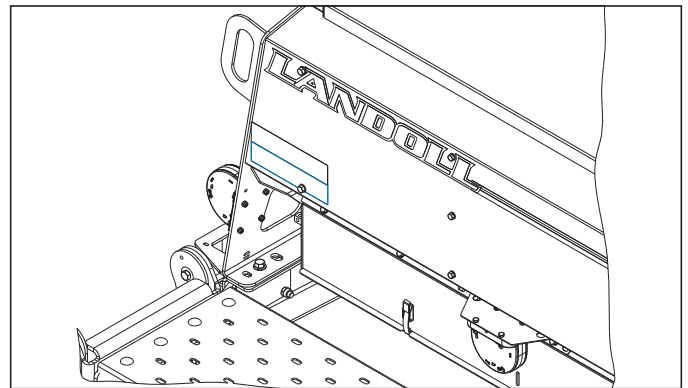

**P/N 528933  
Red Reflector**



Middle of rear side of box, bottom, 5211-15' & 5211-20'

**QTY. 2**

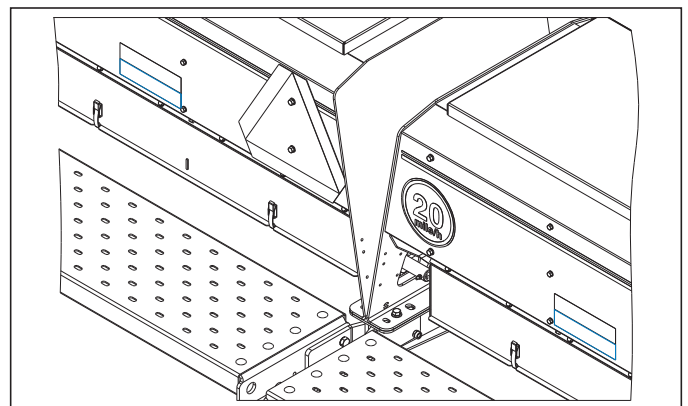

**P/N 528934  
Yellow Reflector**



Front side of RH and LH marker mounts  
**QTY. 2**

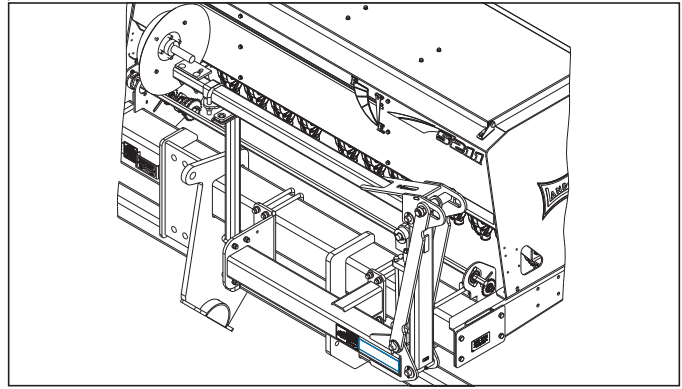

**P/N 528938  
Orange Reflector**



Outer ends of rear side of box, top  
**QTY. 2**

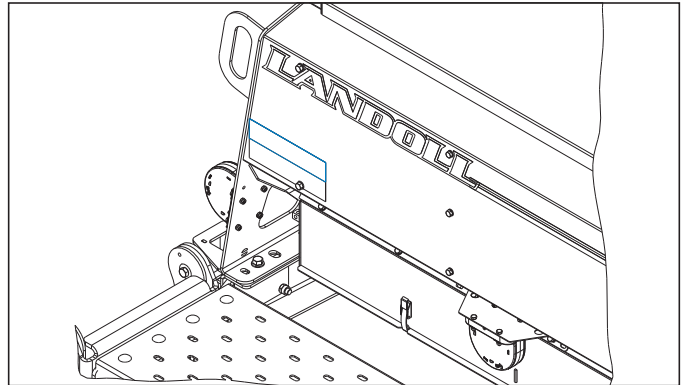

**P/N 528938  
Orange Reflector**



Middle of rear side of boxes, top, 5211-15' & 5211-20'  
**QTY. 2**

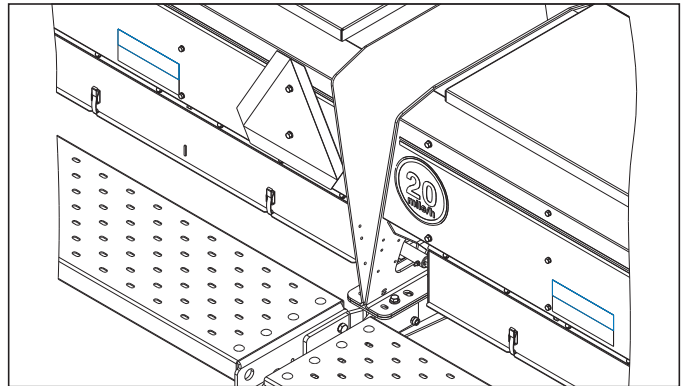

**P/N 224589  
SIS 20 mile/h**



Back of seed box  
**QTY. 1**

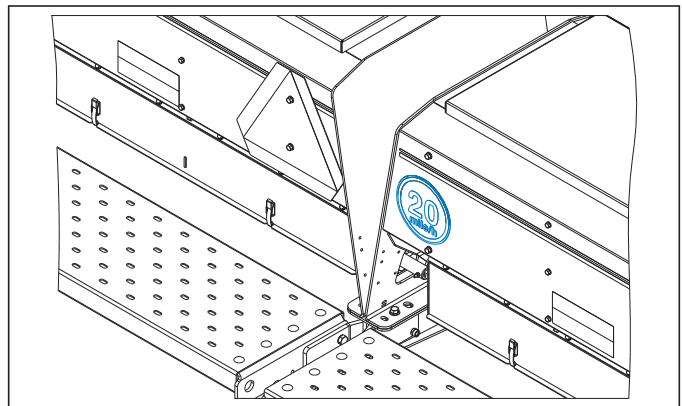

**P/N 224589**  
**SIS 20 mile/h**



Back of small seed boxes  
**QTY. 1**

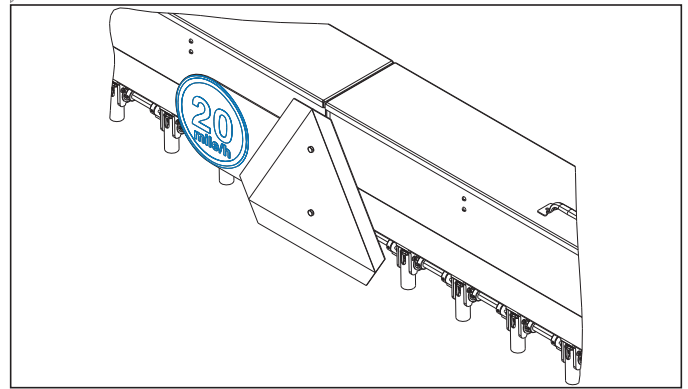

**P/N 70260977**  
**SMV EMBLEM**

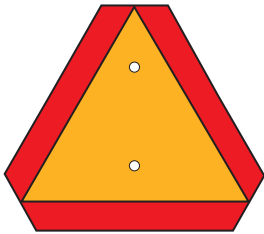

Back of seed box  
**QTY. 1**

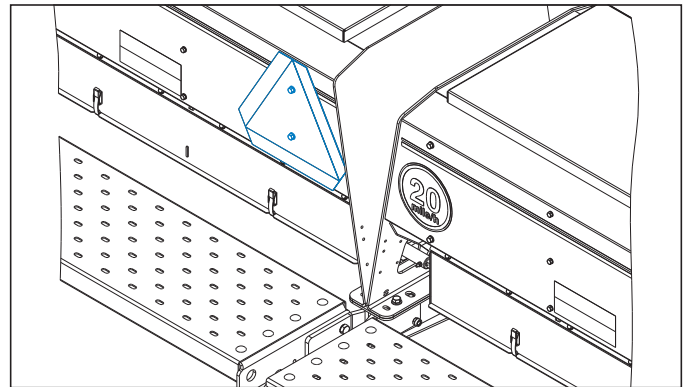

**P/N 70260977**  
**SMV EMBLEM**

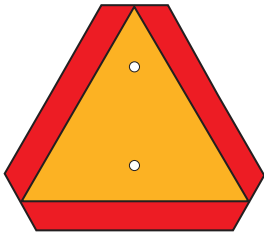

Back of small seed boxes  
**QTY. 1**

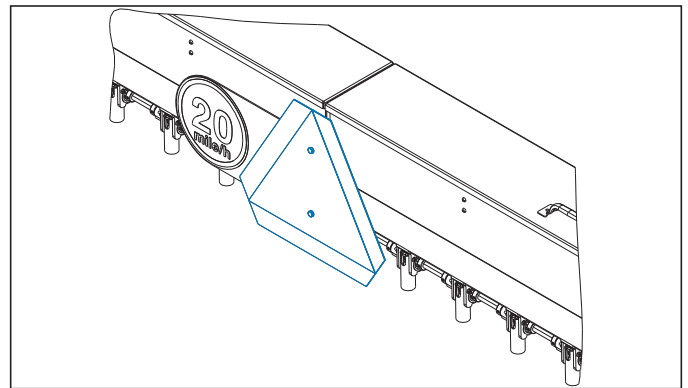

**P/N 141597**  
**ELECTROCUTION HAZARD**

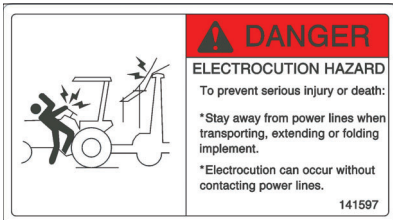

Front side of RH and LH marker mounts  
**QTY. 2**

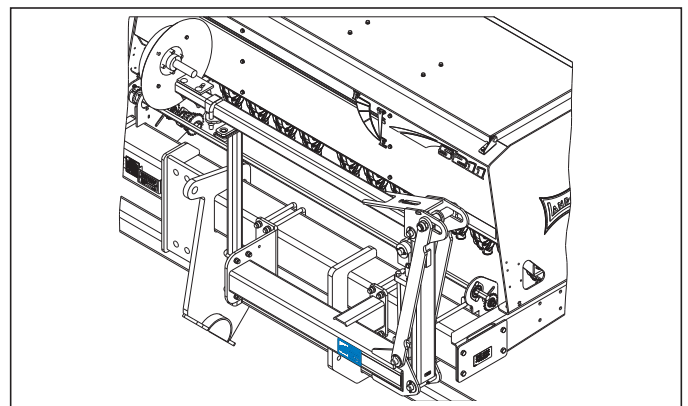



# Specifications

## Introduction

This manual is compiled as a guide for owners and operators of the 5211 grain drill. Read it carefully so as to be able to follow the suggestions made. Please take time to understand the proper maintenance schedule and SAFE operation of your equipment.

In the event that a new and inexperienced operator is placed in charge of running the equipment, they should read and understand, that part of the manual for proper maintenance and SAFE operation, and to be trained in regard by an experienced operator.

## Owner Assistance

If customer service or repairs are needed, contact your Landoll dealer. They have trained personnel, parts and service equipment specially designed for Landoll products. Your machine's parts should only be replaced with Landoll parts. Have the Serial Number and complete Model Number available when ordering parts from your Landoll dealer *See Figure 2-1*

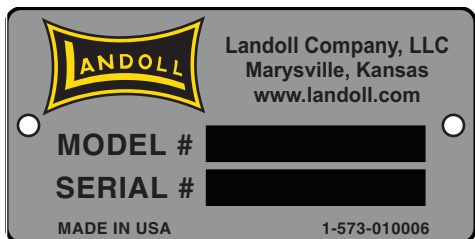

**Figure 2-1: Serial Number Plate**

## Warranty Registration

Be certain to register the grain drill Online registration at [www.landoll.com](http://www.landoll.com) within 10 days of purchase or lease, in order to be on file at Landoll and eligible for Warranty.

Take time to read and understand the Warranty for this product, *See Figure 2-2* and *See Figure 2-3*

Landoll reserves the right to make changes and/or add improvements to it's products at any time without obligation to previously manufactured equipment.

Please take time to complete the following information for your personal reference, should you need to contact your Dealer with questions or parts needs.

**MODEL** \_\_\_\_\_

**SERIAL #** \_\_\_\_\_

**DATE OF PURCHASE** \_\_\_\_\_

**DEALER NAME** \_\_\_\_\_

We at Landoll wish to thank you for purchasing our product. We have spent considerable time and effort to research, design, test and develop this machine and are confident it will serve you in the use for which it was designed.



## **LANDOLL TILLAGE PRODUCT THREE YEAR LIMITED WARRANTY**

Landoll Company, LLC warrants each new serial numbered Whole Good Tillage product, when properly assembled, adjusted, serviced, and normally operated, to be free from defects in materials and workmanship for a period of three (3) years, unless otherwise noted, from the date of delivery. Date of delivery shall be the date the Dealer places the product in the possession of the original retail purchaser, and must be confirmed by the Dealer submitting a properly completed Landoll Company, LLC Warranty Registration Form to the Landoll Company, LLC Warranty Department. Warranty starts the day the product is rented or leased. This limited warranty shall be transferable until the expiration date.

Landoll Company, LLC shall repair, or at its option, replace any part(s) of the product determined, by Landoll Company, LLC, to be defective. Landoll Company, LLC may request the return of part(s), freight prepaid via a carrier approved by the Landoll Warranty Staff, to Landoll Company, LLC for further evaluation. If the part is determined to be defective, Landoll Company, LLC will refund the freight charges incurred in returning the defective part(s), and will prepay replacement part(s) freight charges.

This limited warranty requires pre-authorization by the Landoll Company, LLC Warranty Staff of any warranty related utilization of components or labor, and is subject to specific exclusions and does not apply to any product which has been: 1) subjected to or operated in a manner which, at any time, have exceeded the product design limits; 2) repaired or altered outside our factory in any way so as, in the judgment of Landoll Company, LLC, to affect its stability or reliability; 3) subject to misuse, negligence, accident, or has been operated in a manner expressly prohibited in the instructions; or not operated in accordance with practices approved by Landoll Company, LLC. Operating the product in soils containing rocks, stumps or obstructions may void the warranty in its entirety. Excessive acres, consistent with nonseasonal very large farming operations, and, non-agricultural activities, may further limit the terms of this warranty.

The sole obligation of Landoll Company, LLC under this warranty shall be limited to repairing or replacing, at its option, part(s) which shall be identified to Landoll Company, LLC by way of a pre-authorized Landoll Company, LLC e-mail Warranty Claim Form Warranty, expressed or implied, will be denied on any product not properly registered with the Landoll Company, LLC Warranty Department within ten (10) days of the first retail sale. As stated above, Landoll Company, LLC Warranty Staff will identify components listed on a Warranty Claim required to be returned for further analysis. All parts returned to Landoll Company, LLC must be shipped with a Return Materials Authorization (RMA) provided by the Landoll Company, LLC Warranty Staff. Defective components must be returned by the purchaser to Landoll Company, LLC with transportation and freight charges prepaid within fifteen (15) days after receipt of the RMA. The examination conducted by Landoll Company, LLC of returned parts shall disclose to its satisfaction the extent the component may be defective. All parts and labor warranty MUST be pre-authorized by Landoll Company, LLC Warranty Staff. Failure to do so may result in no warranty payment of any kind. Labor will be reimbursed in accordance with published shop rates pre-approved by the Landoll Company, LLC Warranty Staff. Time authorized for specific work will be limited, where appropriate, to the hours listed in the Landoll Company, LLC authorized Labor Rate Guide.

**Figure 2-2: Landoll Tillage Warranty (1 of 2)**

**LANDOLL TILLAGE PRODUCT THREE YEAR LIMITED WARRANTY (Continued)**

**USER'S OBLIGATION:**

1. Read the Operator's Manual
2. Understand the safe and correct operating procedures pertaining to the operation of the product.
3. Lubricate and maintain the product according to the maintenance schedule in the Operator's Manual.
4. Inspect machine and have parts repaired or replaced when continued use of the produce would cause damage or excessive wear to other parts.
5. Contact the Landoll Company, LLC Dealer for repair or replacement of defective parts. Mileage incurred by the Landoll Company, LLC Dealer is the customer's responsibility.

**This 3-Year Limited Warranty SHALL NOT APPLY TO:**

(See Warranty Procedure Manual for details.)

1. Ground Engaging Tools
2. Vendor Warranty Only Parts

**WARRANTY LABOR:**

1. Considered during the first year of warranty only.
2. During the second and third year:
  - Warranty labor is not covered. Customer is responsible for removing, replacing and returning the defective part(s) to the Landoll Dealer

**THIS WARRANTY IS EXPRESSIVELY IN LIEU OF ALL OTHER WARRANTIES OF MATERIAL, WORKMANSHIP, DESIGN, APPLICATION OR OTHERWISE WITH RESPECT TO ANY EQUIPMENT, WHETHER EXPRESS, IMPLIED OR STATUTORY, INCLUDING WARRANTIES OF MERCHANTABILITY AND FITNESS FOR A PARTICULAR PURPOSE, AND LANDOLL COMPANY, LLC SHALL NOT BE LIABLE FOR SPECIAL OR CONSEQUENTIAL DAMAGES OF ANY KIND ON ACCOUNT OF ANY LANDOLL PRODUCT.**

**NO EMPLOYEE OR REPRESENTATIVE IS AUTHORIZED TO CHANGE THIS WARRANTY, VERBALLY OR IN WRITING, OR GRANT ANY OTHER WARRANTY. LANDOLL COMPANY, LLC, WHOSE POLICY IS ONE OF CONTINUOUS IMPROVEMENT, RESERVES THE RIGHT TO MAKE CHANGES WITHOUT OBLIGATION TO MODIFY PREVIOUSLY PRODUCED EQUIPMENT.**

This warranty does not expand, enlarge upon or alter in any way, the warranties provided by the original manufacturers and suppliers of component parts and accessories. This warranty excludes such parts or accessories which are not defective, but may wear out and have to be replaced during the warranty period, including, but not limited to, light bulbs, paint, and the like. (Tire Warranties are expressly excluded from Landoll Company, LLC warranty herein.) Purchaser is expected to pay all repairs or replacement costs, in connection with this Agreement, including sales and other taxes immediately upon completion of work performed.

**LIMITATION OF LIABILITY:** Landoll Company, LLC shall not be liable to purchaser for any incidental or consequential damages suffered by the purchaser, including, but not limited to, any commercially reasonable charges, expenses or commissions incurred in connection with effecting cover or any other reasonable expense incident to the delay or other breach of warranty by Landoll Company, LLC, loss of anticipated profits, transportation expenses due to repairs, non-operation or increased expense of operation costs of purchased or replaced equipment, claim of customers, cost of money, any loss of use of capital or revenue, equipment rental, service trips, or for any special damage or loss of any nature arising at any time or from any cause whatsoever.

**LIMITATION OF REMEDY:** In the event of Landoll Company, LLC failure to repair the product subject to the warranty contained herein, the purchaser's sole and exclusive remedy against Landoll Company, LLC shall be for the repair or replacement of any defective part or parts of the product subject to work or repair within the time period and manner set forth herein.

This exclusive remedy shall not be deemed to have failed of its essential purpose so long as Landoll Company, LLC is willing and able to repair or replace defective parts in the prescribed manner.

**Figure 2-3: Landoll Tillage Warranty (2 of 2)**

## TABLE OF CONTENTS

### Model Specifications

<b>5211 SERIES GRAIN DRILL</b>					
<b>Model Number</b>	<b>Working Width</b>	<b>Row Spacing</b>	<b>No. of Openers</b>	<b>Transport Width</b>	<b>Estimated Weight</b>
5211-10X6	10 - 0"	6"	20	10' - 5"	8,731 LBS.
5211-10X7.5	10 - 0"	7-1/2"	16	10' - 5"	8,411 LBS.
5211-10X10	10 - 0"	10"	12	10' - 5"	8,003 LBS.
5211-12X6	12 - 6"	6"	25	12' - 11"	10,435 LBS.
5211-12X7.5	12 - 6"	7-1/2"	20	12' - 11"	10,035 LBS.
5211-12X10	12 - 6"	10"	15	12' - 11"	9,525 LBS.
5211-15X6	15 - 0"	6"	30	15' - 8"	12,641 LBS.
5211-15X7.5	15 - 0"	7-1/2"	24	15' - 8"	12,041 LBS.
5211-15X10	15 - 0"	10"	18	15' - 8"	11,312 LBS.
5211-20X6	20"	6"	40	20' - 1"	13,972 LBS.
5211-20X7.5	20"	7-1/2"	32	20' - 1"	13,172 LBS.
5211-20X10	20"	10"	24	20' - 1"	12,200 LBS.

**NOTE: Specifications Are Subject To Change Without Prior**

## TABLE OF CONTENTS

### 5211 SERIES GRAIN DRILL W/DRY FERTILIZER

Model Number	Working Width	Row Spacing	No. of Openers	Transport Width	Estimated Weight
5211-10X7.5	10 - 0"	7-1/2"	16	10' - 0"	8,990 LBS.
5211-10X10	10 - 0"	10"	12	10' - 0"	8,502 LBS.
5211-12X7.5	12 - 6"	7-1/2"	20	12' - 6"	10,080 LBS.
5211-12X10	12 - 6"	10"	15	12' - 6"	9,830 LBS.
5211-15X7.5	15 - 0"	7-1/2"	24	15' - 0"	12,407 LBS.
5211-15X10	15 - 0"	10"	18	15' - 0"	11,662 LBS.
5211-20X7.5	20"	7-1/2"	32	20' - 0"	13,682 LBS.
5211-20X10	20"	10"	24	20' - 0"	12,690 LBS.

**NOTE: Specifications Are Subject To Change Without Prior**

### 5211 SERIES GRAIN DRILL W/SMALL GRASS SEED

Model Number	Working Width	Row Spacing	No. of Openers	Transport Width	Estimated Weight
5211-10X7.5	10' - 0"	7-1/2"	16	10' - 0"	9,029 LBS.
5211-12X7.5	12.5' - 0"	7-1/2"	20	12' - 6"	10,793 LBS.
5211-15X7.5	15' - 0"	7-1/2"	24	15' - 0"	12,436 LBS.
5211-20X7.5	20' - 0"	7-1/2"	32	20' - 0"	13,722 LBS.

**NOTE: Specifications Are Subject To Change Without Prior**

## TABLE OF CONTENTS

### 5211 SERIES GRAIN DRILL CAPACITIES

Model	Seed Box Capacity	Seed/Fertilizer		Small Seed Box Capacity
		Seed Box Capacity	Fertilizer Box Capacity	
5211-10	32.5 Bushels	20 Bushels	1,050 LBS.	3.6 Bushels
5211-12-1/2	40.6 Bushels	25 Bushels	1,313 LBS.	4.7 Bushels
5211-15	48.8 Bushels	30 Bushels	1,575 LBS.	5.3 Bushels
5211-20	65 Bushels	40 Bushels	2,100LBS.	7.2 Bushels

**NOTE: Specifications Are Subject To Change Without Prior**

### Tire Inflation

Tire Size	Tire Manufacturer	Ply/Load Rating	Inflation Pressure (Psi) (Max.)
11L X 15	Good Year	12 Ply/3200 LBS. @30MPH	52 psi
280/70R15	Firestone	LOAD INDEX 134/4680 LBS. @ 40MPH	64 psi

### Recommended Torque Specification For Lug Bolts and Nuts

Bolt Size	Torque (FT. LBS.)
5/8-18	85 - 100 FT. LBS.
9/16-18	80 - 90 FT. LBS.

# General Torque Specifications

**LANDOLL**  
**FASTENER TORQUE SPECIFICATIONS**  
 (Rev. 23/04)

This chart provides general torque specifications for Standard Nuts and Caps Screws (as received condition) that are not called out on processes or drawings.



This **DOES NOT** apply if special lubrication such as graphite moly-disulfide or other extreme pressure lubricants are used.

Add 33% to the listed torque specification if the fastener is dry (solvent cleaned).

Cap screw grades are indicated by markings on the head, these vary among manufacturers.

Thick Nuts must be used on grade 8 cap screws.



**SAE TORQUE SPECIFICATIONS (FOOT-POUNDS)**  
 [ ] Indicates specifications for Prevailing Torque Nuts.

UNC Size	 Grade 2	 Grade 5	 Grade 8
1/4 - 20	4 [5]	6 [7]	9 [11]
5/16 - 18	8 [10]	13 [16]	18 [22]
3/8 - 16	15 [19]	23 [29]	35 [43]
7/16 - 14	24 [30]	35 [43]	55 [62]
1/2 - 13	35 [43]	55 [62]	80 [100]
9/16 - 12	55 [62]	80 [100]	110 [137]
5/8 - 11	75 [94]	110 [137]	170 [212]
3/4 - 10	130 [162]	200 [250]	280 [350]
7/8 - 9	125 [156]	320 [400]	460 [575]
1 - 8	190 [237]	408 [506]	680 [850]
1-1/8 - 7	270 [337]	600 [750]	960 [1200]
1-1/4 - 7	380 [475]	840 [1050]	1426 [1782]
1-3/8 - 6	490 [612]	1100 [1375]	1780 [2225]
1-1/2 - 6	650 [812]	1460 [1825]	2360 [2950]

See back side for SAE UNF and Metric torques.

Form No. F-257-0322

**SAE TORQUE SPECIFICATIONS (FOOT POUNDS)**  
 [ ] Indicates specifications for Prevailing Torque Nuts.

UNF Size	 Grade 2	 Grade 5	 Grade 8
1/4 - 28	5 [6]	7 [9]	10 [12]
5/16 - 24	9 [11]	14 [17]	20 [25]
3/8 - 24	17 [21]	25 [31]	35 [44]
7/16 - 20	27 [34]	40 [50]	60 [75]
1/2 - 20	40 [50]	65 [81]	90 [122]
9/16 - 18	60 [75]	90 [112]	130 [162]
5/8 - 18	85 [106]	130 [162]	180 [225]
3/4 - 16	150 [188]	220 [275]	320 [400]
7/8 - 14	140 [175]	360 [450]	500 [625]
1 - 14	210 [263]	540 [675]	760 [950]
1-1/8 - 12	300 [375]	660 [825]	1080 [1350]
1-1/4 - 12	420 [525]	920 [1150]	1500 [1875]
1-3/8 - 12	560 [700]	1260 [1575]	2010 [2512]
1-1/2 - 12	730 [912]	1640 [2050]	2660 [3325]

**METRIC TORQUE SPECIFICATIONS**  
 This chart provides torque specification for phosphate coated, Rockwell "C" 38-45 Metric Coarse Thread Class 10.9 Fasteners, Class 10.0 Nuts and Harden Flat Washers.

[ ] Indicates specifications for Prevailing Torque Nuts.

MM Size	Newton - Meters	Foot-Pounds
6	10 [14]	7 [10]
7	16 [22]	12 [16]
8	23 [32]	17 [24]
10	46 [60]	34 [47]
12	80 [101]	60 [75]
14	125 [155]	90 [115]
16	200 [240]	150 [180]
18	275 [330]	205 [245]
20	385 [450]	290 [335]
24	670 [775]	500 [625]
27	980 [1105]	730 [825]
30	1330 [1470]	990 [1090]
33	1790 [1950]	1730 [1870]
36	2325 [2515]	1730 [1870]
39	3010 [3210]	2240 [2380]

See front side for SAE UNC and notes.

**Figure 2-4: General Torque Specifications**

# Hydraulic Fitting Torque Specifications

<p><b>LANDOLL</b> HYDRAULIC FITTING TORQUE SPECIFICATIONS (REV. 23/04) <b>AEROQUIP BRAND FITTINGS</b> 37° JIC; ORS &amp; ORB</p> <p>This chart provides torque specifications for Plated Carbon Steel and Stainless Steel Fittings (as received condition) that are not called out on processes or drawings.</p> <p>This <b>DOES NOT</b> apply if special lubrication such as graphite moly-disulfide or other extreme pressure lubricants are used.</p> <p>Minus 65% from the listed torque specification for Brass Fittings.</p>	<p><b>LANDOLL</b> HYDRAULIC FITTING TORQUE SPECIFICATIONS (REV. 23/04) <b>GATES BRAND FITTINGS</b> 37° JIC; ORS &amp; ORB</p> <p>This chart provides torque specifications for Plated Carbon Steel and Stainless Steel Fittings (as received condition) that are not called out on processes or drawings.</p> <p>This <b>DOES NOT</b> apply if special lubrication such as graphite moly-disulfide or other extreme pressure lubricants are used.</p> <p>Minus 65% from the listed torque specification for Brass Fittings.</p>	<p><b>LANDOLL</b> HYDRAULIC FITTING TORQUE SPECIFICATIONS (REV. 23/04) <b>PARKER BRAND FITTINGS</b> 37° JIC; ORS &amp; ORB</p> <p>This chart provides torque specifications for Plated Carbon Steel and Stainless Steel Fittings (as received condition) that are not called out on processes or drawings.</p> <p>This <b>DOES NOT</b> apply if special lubrication such as graphite moly-disulfide or other extreme pressure lubricants are used.</p> <p>Minus 65% from the listed torque specification for Brass Fittings.</p>																																																																																																																																																
<p><b>TORQUE SPECIFICATIONS (FOOT-POUNDS)</b> [ ] Indicates specifications for Prevailing Torque Nuts.</p> <table border="1" style="width:100%; border-collapse: collapse; text-align: center;"> <thead> <tr> <th>DASH Size</th> <th>37 Degree JIC</th> <th>O-Ring (ORS)</th> <th>O-Ring Boss (ORB)</th> </tr> </thead> <tbody> <tr><td>-4</td><td>11-12</td><td>10-12</td><td>14-16</td></tr> <tr><td>-5</td><td>15-16</td><td>-----</td><td>18-20</td></tr> <tr><td>-6</td><td>18-20</td><td>18-20</td><td>24-26</td></tr> <tr><td>-8</td><td>38-42</td><td>32-35</td><td>50-60</td></tr> <tr><td>-10</td><td>57-62</td><td>46-50</td><td>72-80</td></tr> <tr><td>-12</td><td>79-87</td><td>65-70</td><td>125-135</td></tr> <tr><td>-14</td><td>-----</td><td>-----</td><td>160-180</td></tr> <tr><td>-16</td><td>108-113</td><td>92-100</td><td>200-220</td></tr> <tr><td>-20</td><td>127-133</td><td>125-140</td><td>240-280</td></tr> <tr><td>-24</td><td>158-167</td><td>150-165</td><td>270-360</td></tr> <tr><td>-32</td><td>245-258</td><td>-----</td><td>-----</td></tr> </tbody> </table>	DASH Size	37 Degree JIC	O-Ring (ORS)	O-Ring Boss (ORB)	-4	11-12	10-12	14-16	-5	15-16	-----	18-20	-6	18-20	18-20	24-26	-8	38-42	32-35	50-60	-10	57-62	46-50	72-80	-12	79-87	65-70	125-135	-14	-----	-----	160-180	-16	108-113	92-100	200-220	-20	127-133	125-140	240-280	-24	158-167	150-165	270-360	-32	245-258	-----	-----	<p><b>TORQUE SPECIFICATIONS (FOOT-POUNDS)</b> [ ] Indicates specifications for Prevailing Torque Nuts.</p> <table border="1" style="width:100%; border-collapse: collapse; text-align: center;"> <thead> <tr> <th>DASH Size</th> <th>37 Degree JIC</th> <th>O-Ring (ORS)</th> <th>O-Ring Boss (ORB)</th> </tr> </thead> <tbody> <tr><td>-4</td><td>10-11</td><td>10-12</td><td>14-16</td></tr> <tr><td>-5</td><td>13-15</td><td>-----</td><td>-----</td></tr> <tr><td>-6</td><td>17-19</td><td>18-20</td><td>24-26</td></tr> <tr><td>-8</td><td>34-38</td><td>32-40</td><td>37-44</td></tr> <tr><td>-10</td><td>50-56</td><td>46-56</td><td>50-60</td></tr> <tr><td>-12</td><td>70-78</td><td>65-80</td><td>75-83</td></tr> <tr><td>-14</td><td>-----</td><td>65-80</td><td>-----</td></tr> <tr><td>-16</td><td>94-104</td><td>92-105</td><td>111-125</td></tr> <tr><td>-20</td><td>124-138</td><td>125-140</td><td>133-152</td></tr> <tr><td>-24</td><td>156-173</td><td>150-180</td><td>156-184</td></tr> <tr><td>-32</td><td>219-243</td><td>-----</td><td>-----</td></tr> </tbody> </table>	DASH Size	37 Degree JIC	O-Ring (ORS)	O-Ring Boss (ORB)	-4	10-11	10-12	14-16	-5	13-15	-----	-----	-6	17-19	18-20	24-26	-8	34-38	32-40	37-44	-10	50-56	46-56	50-60	-12	70-78	65-80	75-83	-14	-----	65-80	-----	-16	94-104	92-105	111-125	-20	124-138	125-140	133-152	-24	156-173	150-180	156-184	-32	219-243	-----	-----	<p><b>TORQUE SPECIFICATIONS (FOOT-POUNDS)</b> [ ] Indicates specifications for Prevailing Torque Nuts.</p> <table border="1" style="width:100%; border-collapse: collapse; text-align: center;"> <thead> <tr> <th>DASH Size</th> <th>37 Degree JIC</th> <th>O-Ring (ORS)</th> <th>O-Ring Boss (ORB)</th> </tr> </thead> <tbody> <tr><td>-4</td><td>11-13</td><td>15-17</td><td>13-15</td></tr> <tr><td>-5</td><td>14-16</td><td>-----</td><td>21-23</td></tr> <tr><td>-6</td><td>20-22</td><td>34-36</td><td>25-29</td></tr> <tr><td>-8</td><td>43-47</td><td>58-62</td><td>40-44</td></tr> <tr><td>-10</td><td>55-65</td><td>100-110</td><td>58-62</td></tr> <tr><td>-12</td><td>80-90</td><td>134-146</td><td>75-85</td></tr> <tr><td>-14</td><td>-----</td><td>-----</td><td>-----</td></tr> <tr><td>-16</td><td>115-125</td><td>202-218</td><td>109-121</td></tr> <tr><td>-20</td><td>160-180</td><td>248-272</td><td>213-237</td></tr> <tr><td>-24</td><td>185-215</td><td>303-327</td><td>238-262</td></tr> <tr><td>-32</td><td>250-290</td><td>-----</td><td>310-340</td></tr> </tbody> </table>	DASH Size	37 Degree JIC	O-Ring (ORS)	O-Ring Boss (ORB)	-4	11-13	15-17	13-15	-5	14-16	-----	21-23	-6	20-22	34-36	25-29	-8	43-47	58-62	40-44	-10	55-65	100-110	58-62	-12	80-90	134-146	75-85	-14	-----	-----	-----	-16	115-125	202-218	109-121	-20	160-180	248-272	213-237	-24	185-215	303-327	238-262	-32	250-290	-----	310-340
DASH Size	37 Degree JIC	O-Ring (ORS)	O-Ring Boss (ORB)																																																																																																																																															
-4	11-12	10-12	14-16																																																																																																																																															
-5	15-16	-----	18-20																																																																																																																																															
-6	18-20	18-20	24-26																																																																																																																																															
-8	38-42	32-35	50-60																																																																																																																																															
-10	57-62	46-50	72-80																																																																																																																																															
-12	79-87	65-70	125-135																																																																																																																																															
-14	-----	-----	160-180																																																																																																																																															
-16	108-113	92-100	200-220																																																																																																																																															
-20	127-133	125-140	240-280																																																																																																																																															
-24	158-167	150-165	270-360																																																																																																																																															
-32	245-258	-----	-----																																																																																																																																															
DASH Size	37 Degree JIC	O-Ring (ORS)	O-Ring Boss (ORB)																																																																																																																																															
-4	10-11	10-12	14-16																																																																																																																																															
-5	13-15	-----	-----																																																																																																																																															
-6	17-19	18-20	24-26																																																																																																																																															
-8	34-38	32-40	37-44																																																																																																																																															
-10	50-56	46-56	50-60																																																																																																																																															
-12	70-78	65-80	75-83																																																																																																																																															
-14	-----	65-80	-----																																																																																																																																															
-16	94-104	92-105	111-125																																																																																																																																															
-20	124-138	125-140	133-152																																																																																																																																															
-24	156-173	150-180	156-184																																																																																																																																															
-32	219-243	-----	-----																																																																																																																																															
DASH Size	37 Degree JIC	O-Ring (ORS)	O-Ring Boss (ORB)																																																																																																																																															
-4	11-13	15-17	13-15																																																																																																																																															
-5	14-16	-----	21-23																																																																																																																																															
-6	20-22	34-36	25-29																																																																																																																																															
-8	43-47	58-62	40-44																																																																																																																																															
-10	55-65	100-110	58-62																																																																																																																																															
-12	80-90	134-146	75-85																																																																																																																																															
-14	-----	-----	-----																																																																																																																																															
-16	115-125	202-218	109-121																																																																																																																																															
-20	160-180	248-272	213-237																																																																																																																																															
-24	185-215	303-327	238-262																																																																																																																																															
-32	250-290	-----	310-340																																																																																																																																															
FORM NO. F-263-2304 (1 of 3)	FORM NO. F-263-2304 (2 of 3)	FORM NO. F-263-2304 (3 of 3)																																																																																																																																																

**Figure 2-5: Hydraulic Fitting Torque Specifications**

## 5211-10' Opener/Drive/Marker Placement

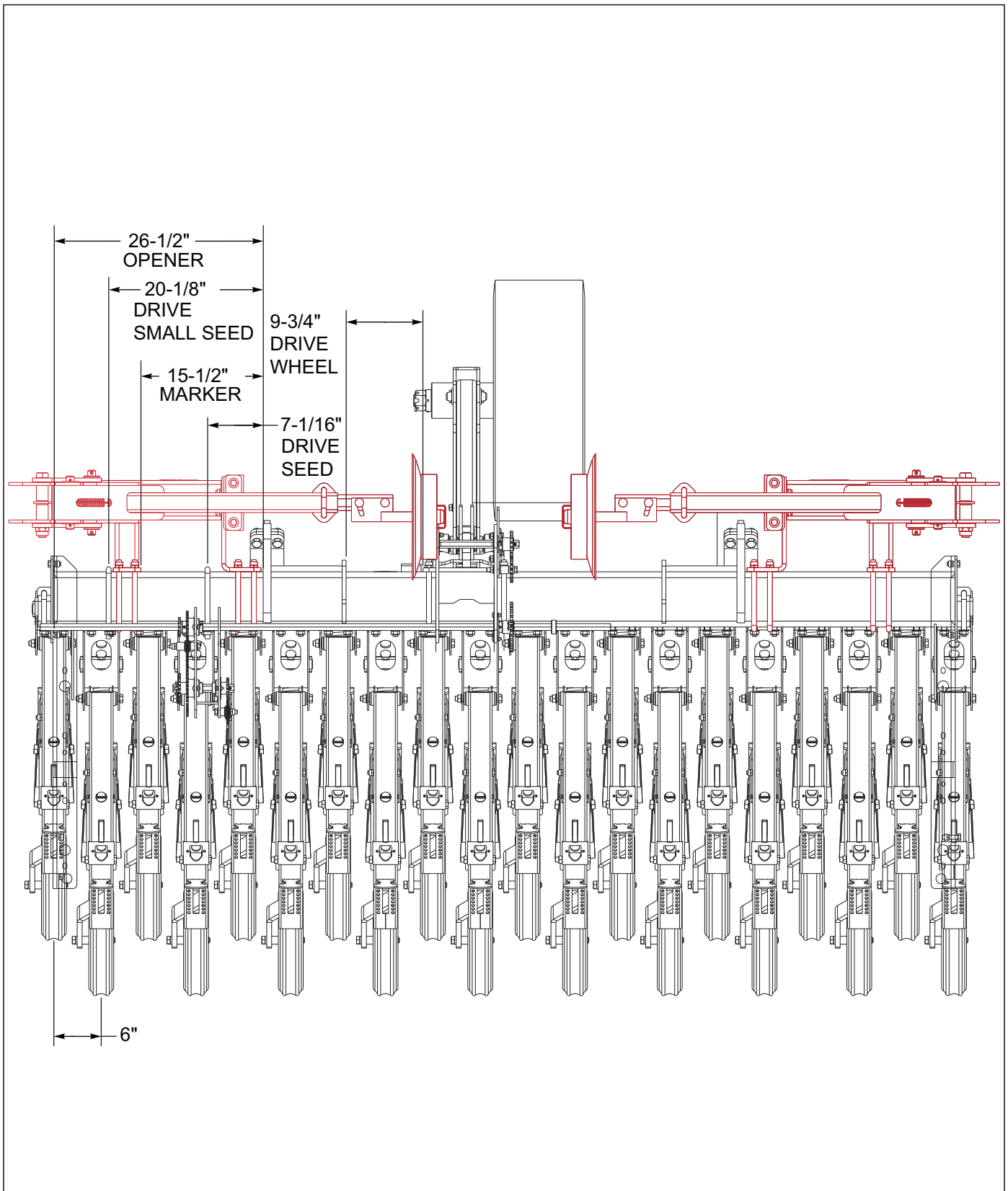

Figure 2-6: 5211-10' 6" Opener/Small Seed/Drive/Marker Placement

# TABLE OF CONTENTS

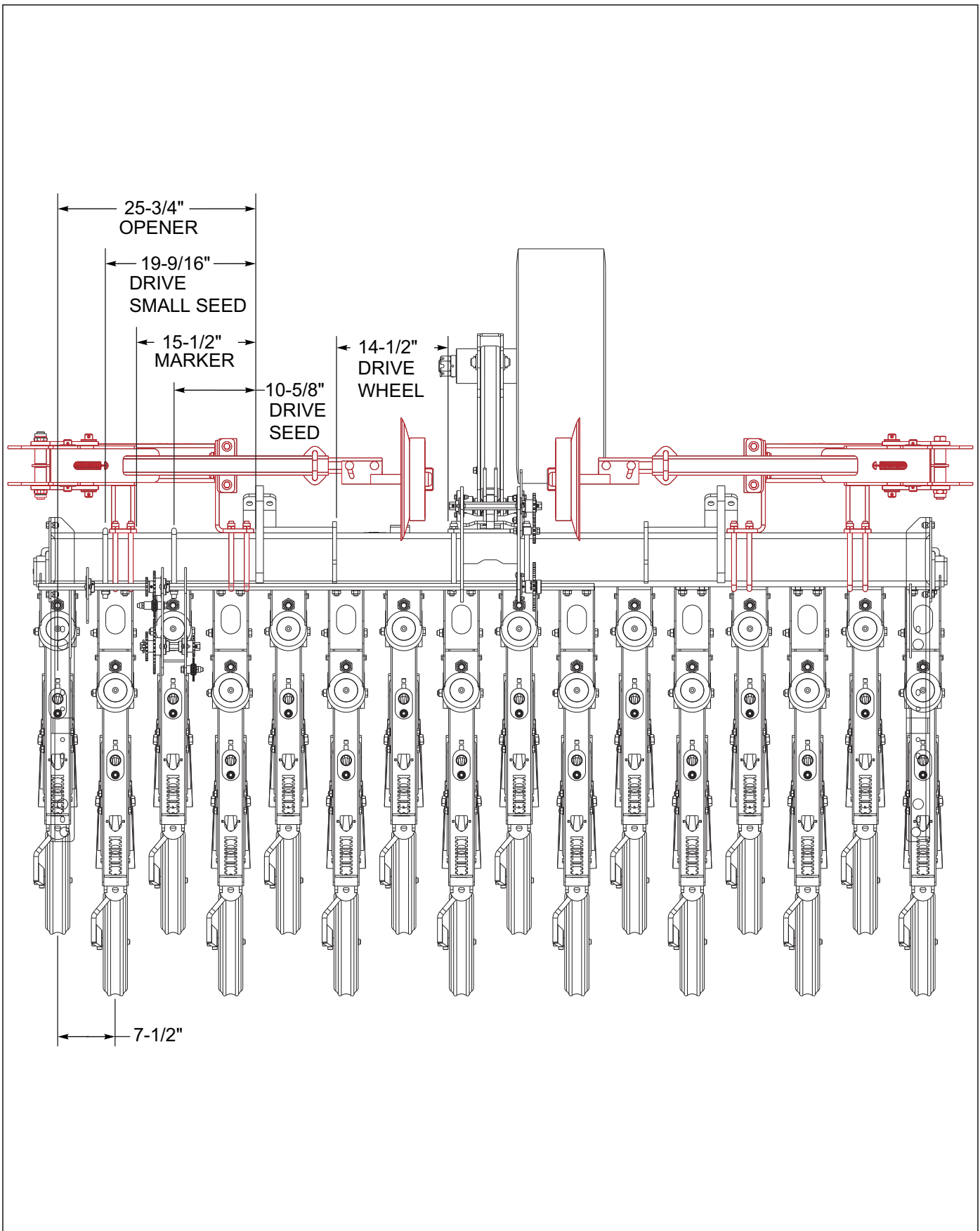

Figure 2-7: 5211-10' 7.5" Spacing Opener/ Small Seed/Drive/Marker Placement

# TABLE OF CONTENTS

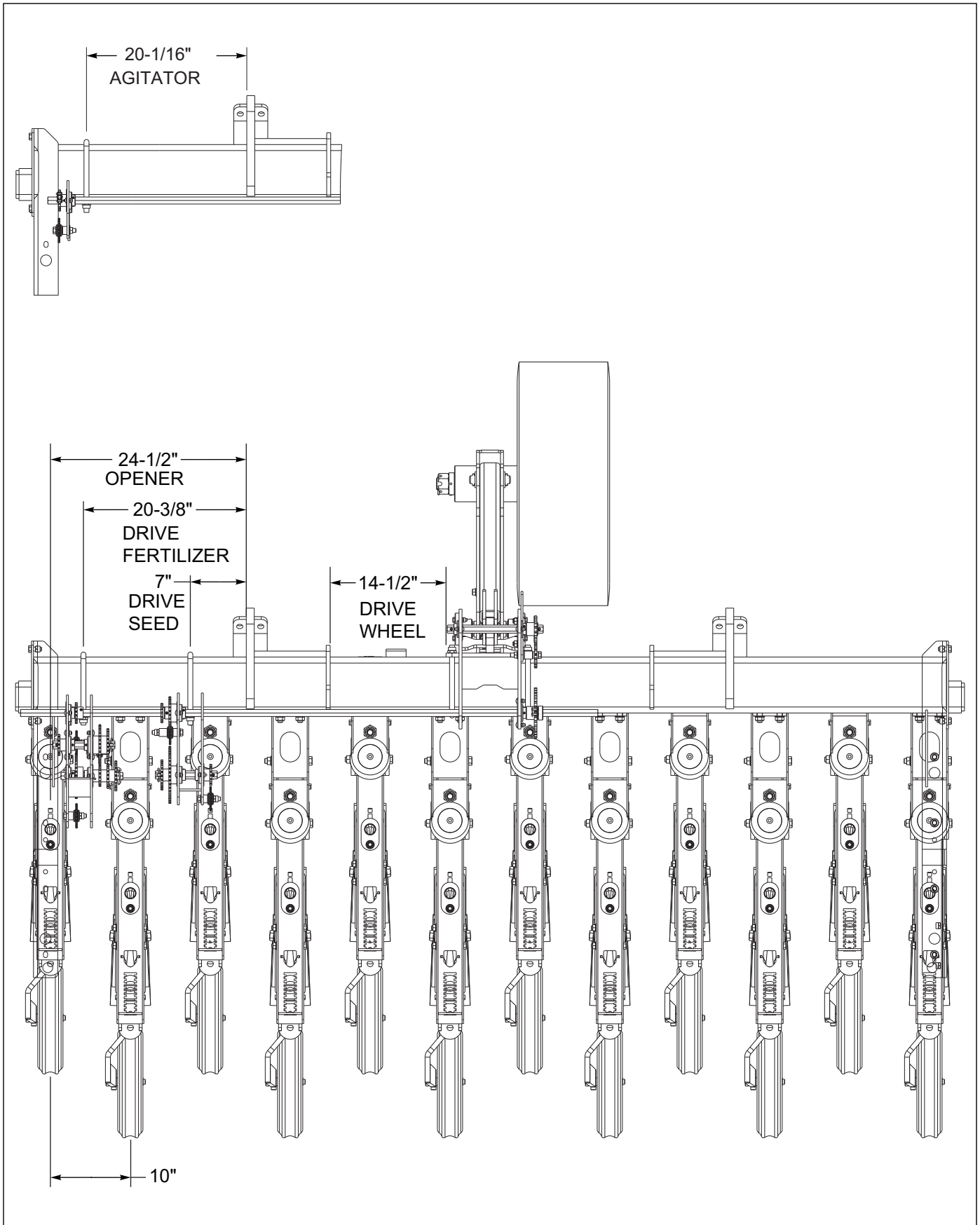

Figure 2-8: 5211-10' 7.5" Spacing Opener/Drive/Fertilizer/Agitator Placement

## 5211-12-1/2' Opener/Drive/Marker Placement

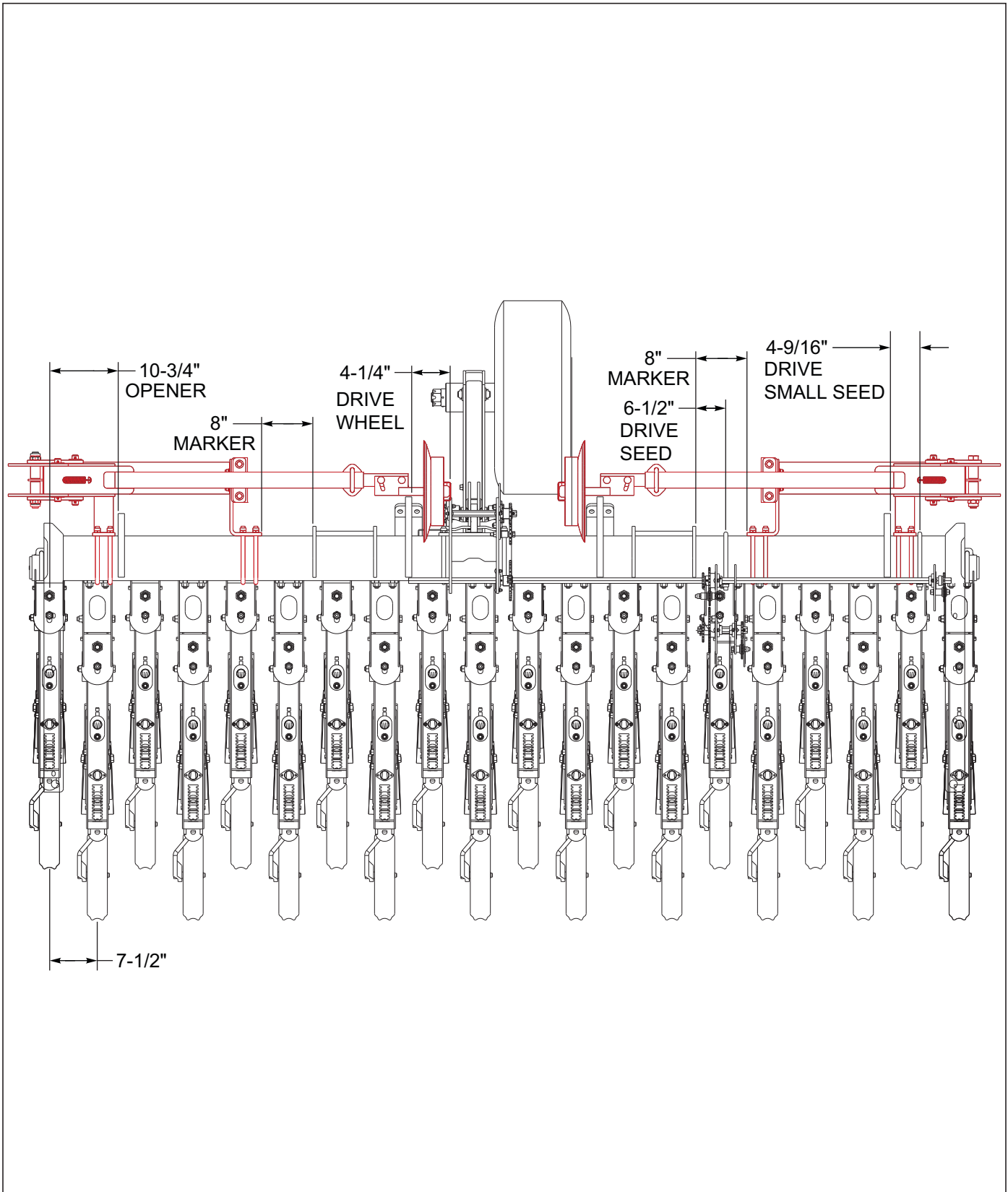

Figure 2-9: 5211-12-1/2' 7.5" Spacing Opener/Drive/ Small Seed/Marker Placement

# TABLE OF CONTENTS

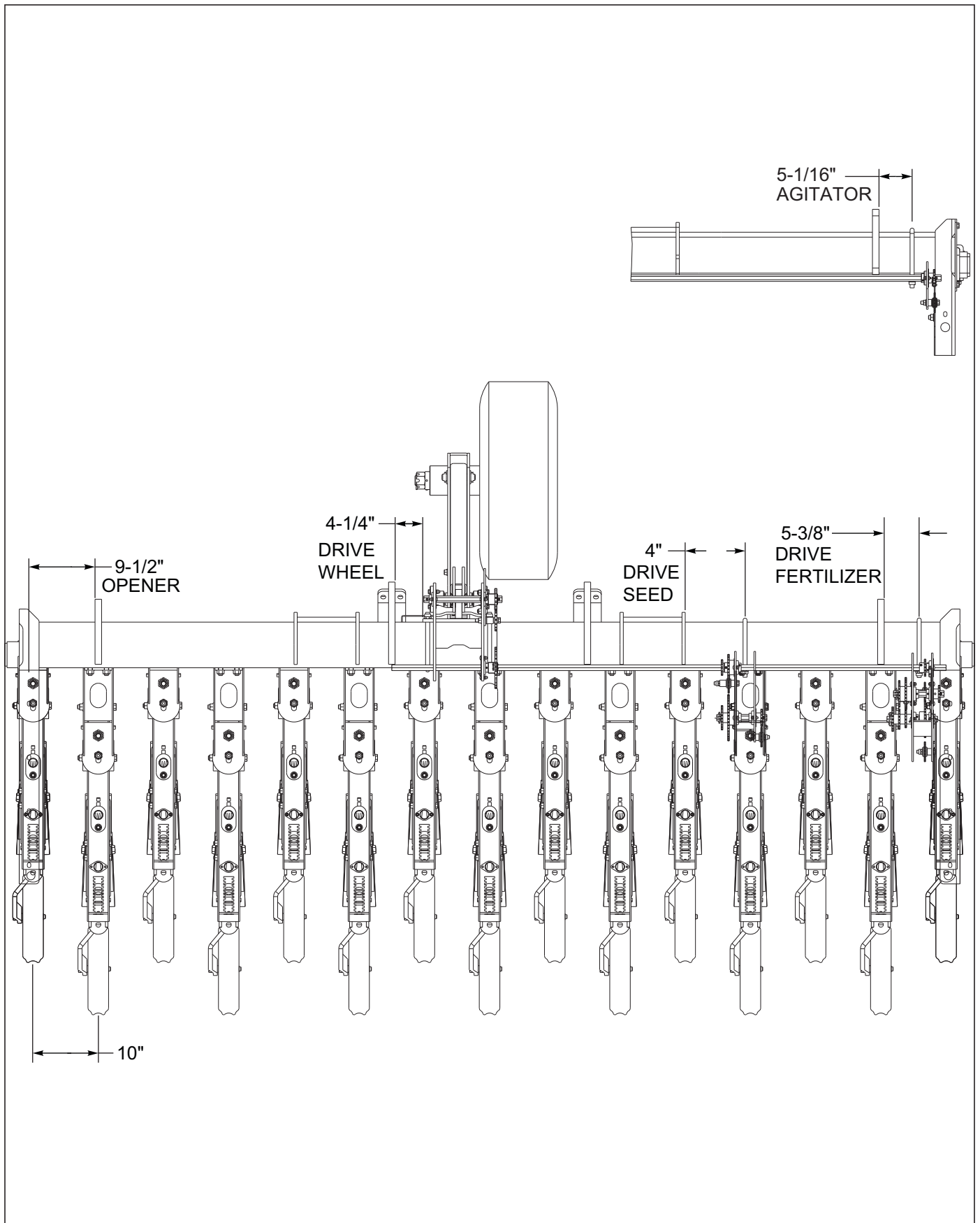

Figure 2-10: 5211-12-1/2' 10'' Spacing Opener/Drive/Fertilizer/Agitator Placement

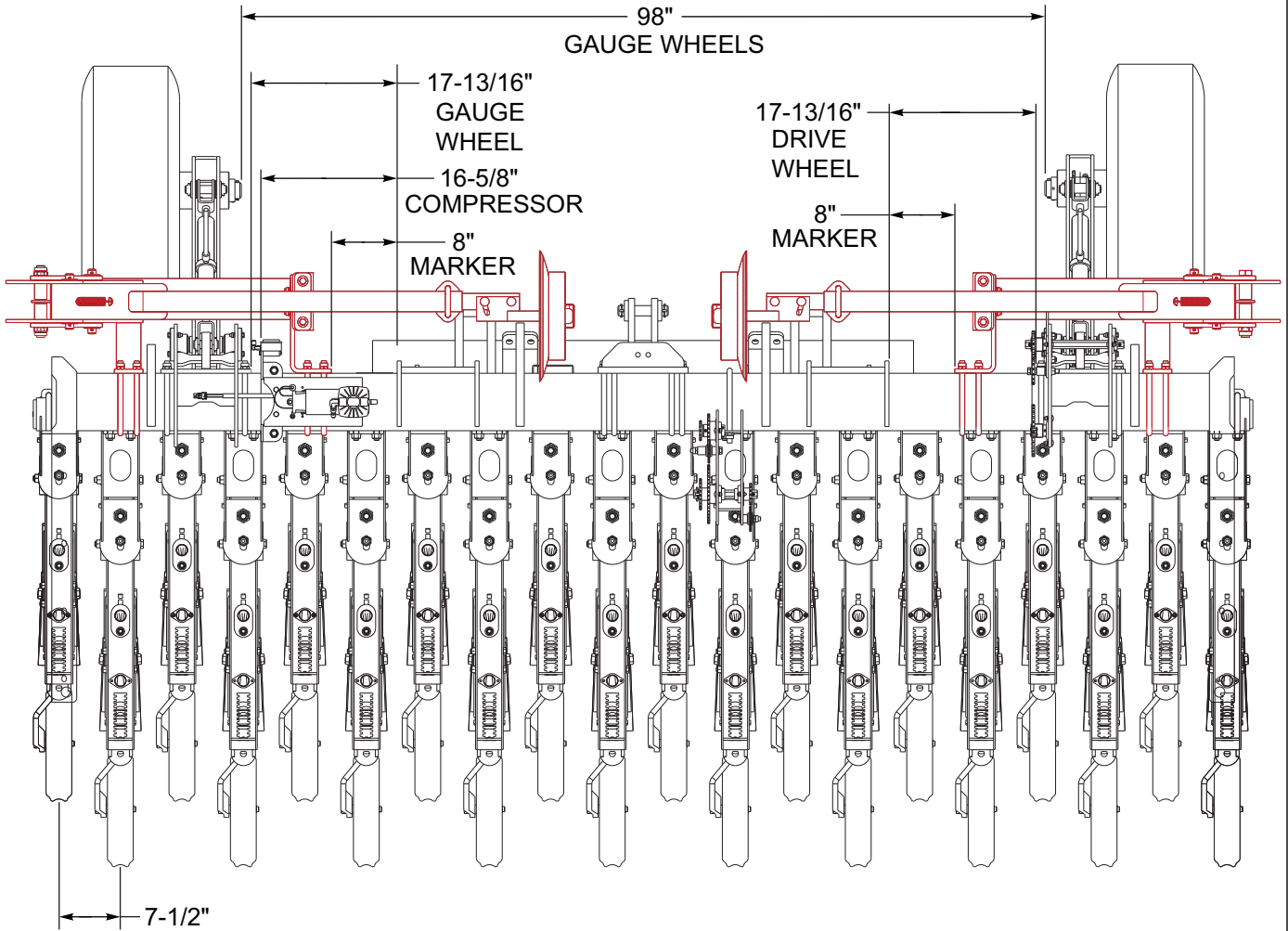

Figure 2-11: 5211-12-1/2' 7-1/2" Spacing 3-Point Opener/Drive/Marker/Gauge Wheel Placement

## 5211-15' Opener/Drive/Marker Placement

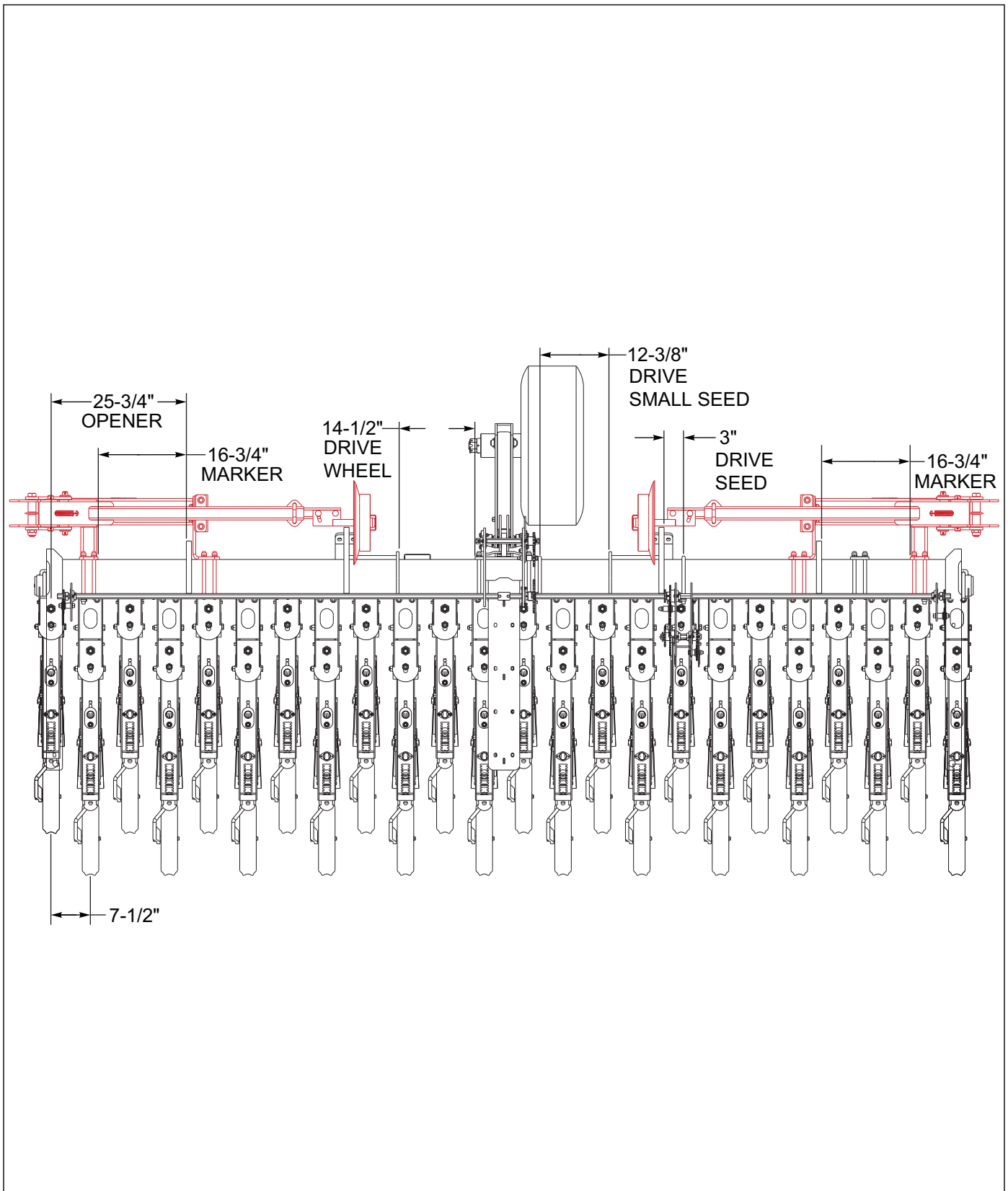

Figure 2-12: 5211-15' 7.5" Spacing Pull Hitch Opener/Drive/Small Seed//Marker Placement

# TABLE OF CONTENTS

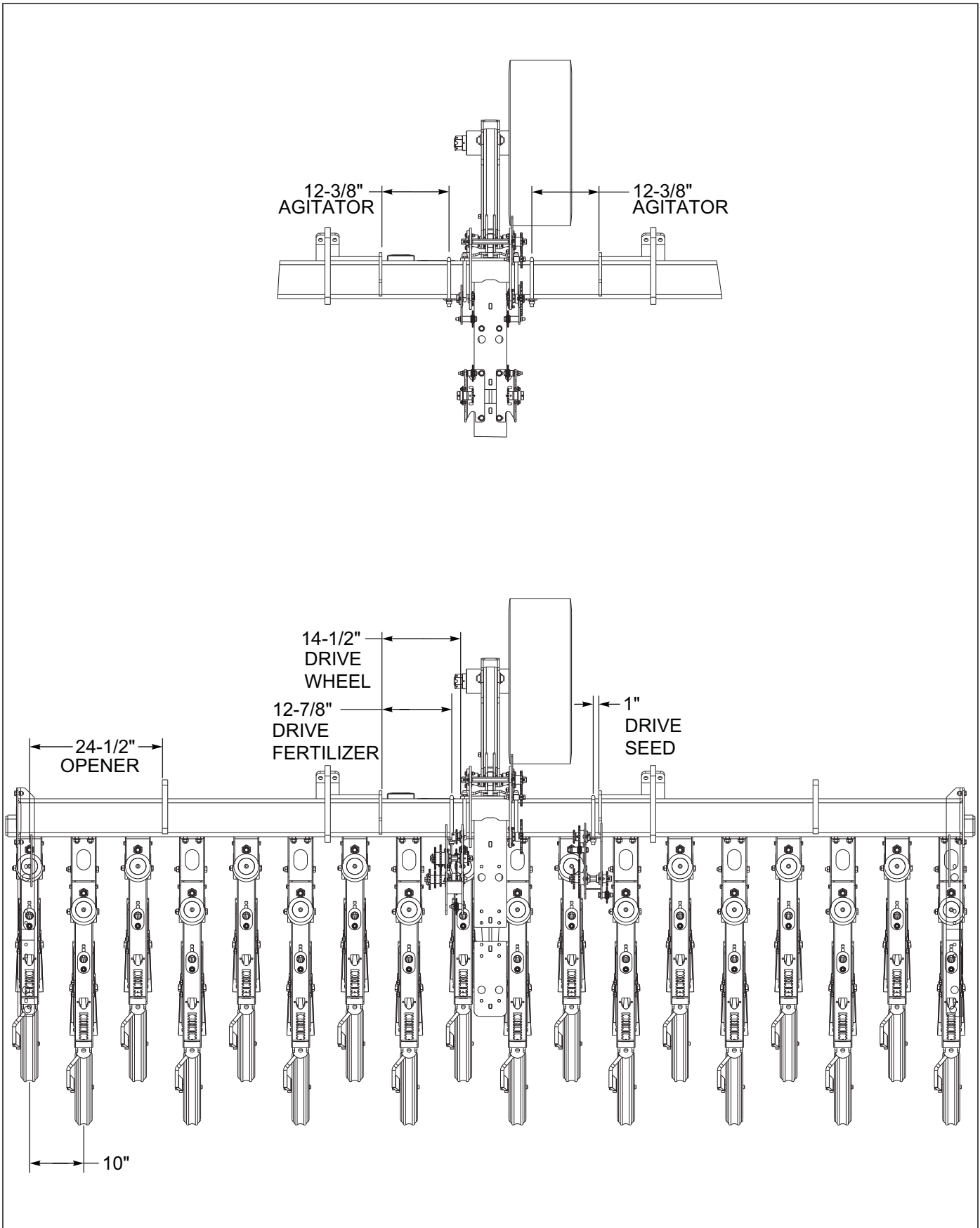

Figure 2-13: 5211-15' 10" Spacing Opener/Drive/Fertilizer/Agitator Placement

# TABLE OF CONTENTS

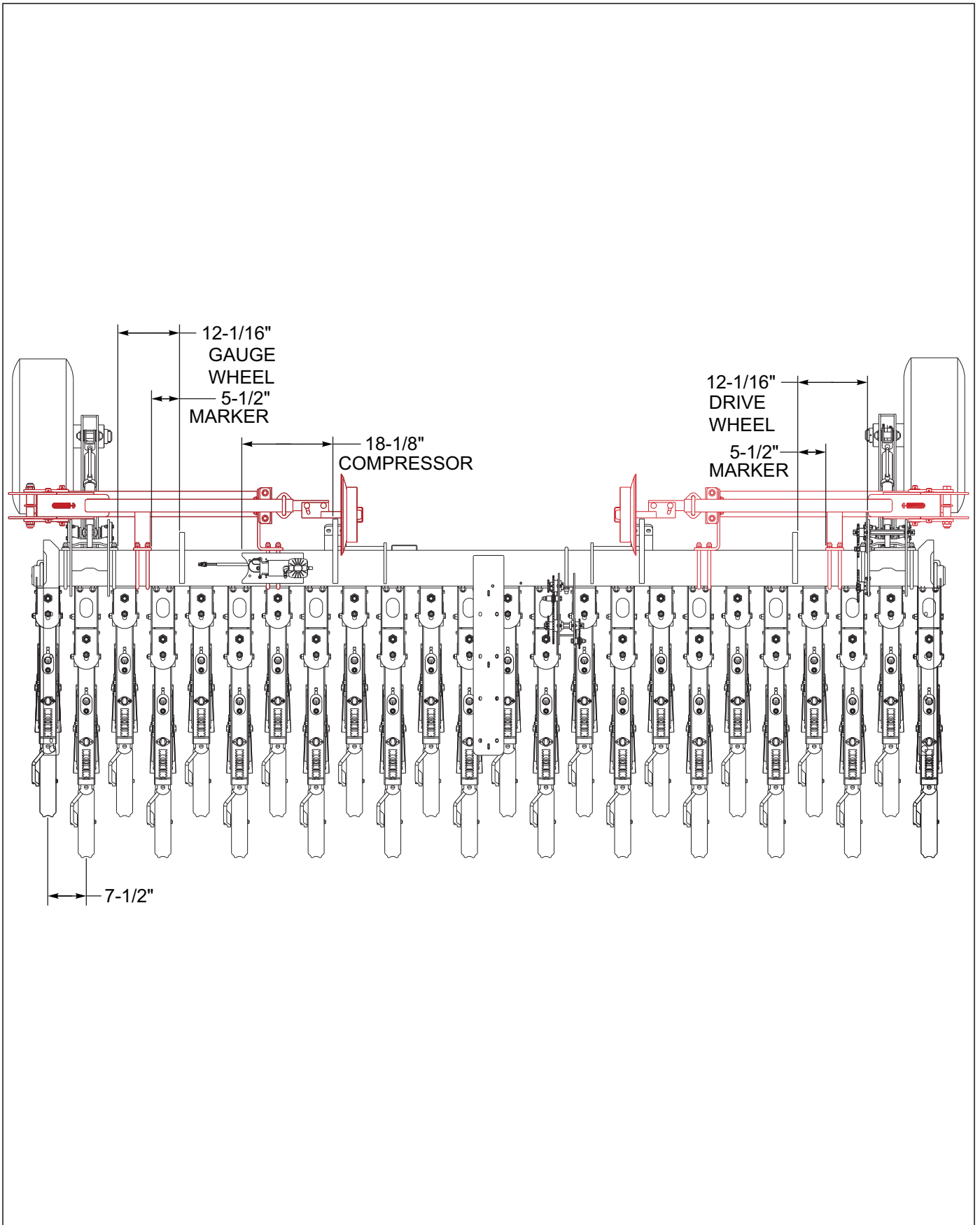

Figure 2-14: 5211-15' 7-1/2'' 3-Point Opener/Drive/Compressor/Marker Placement

## 5211-20' Opener/Drive/Marker Placement

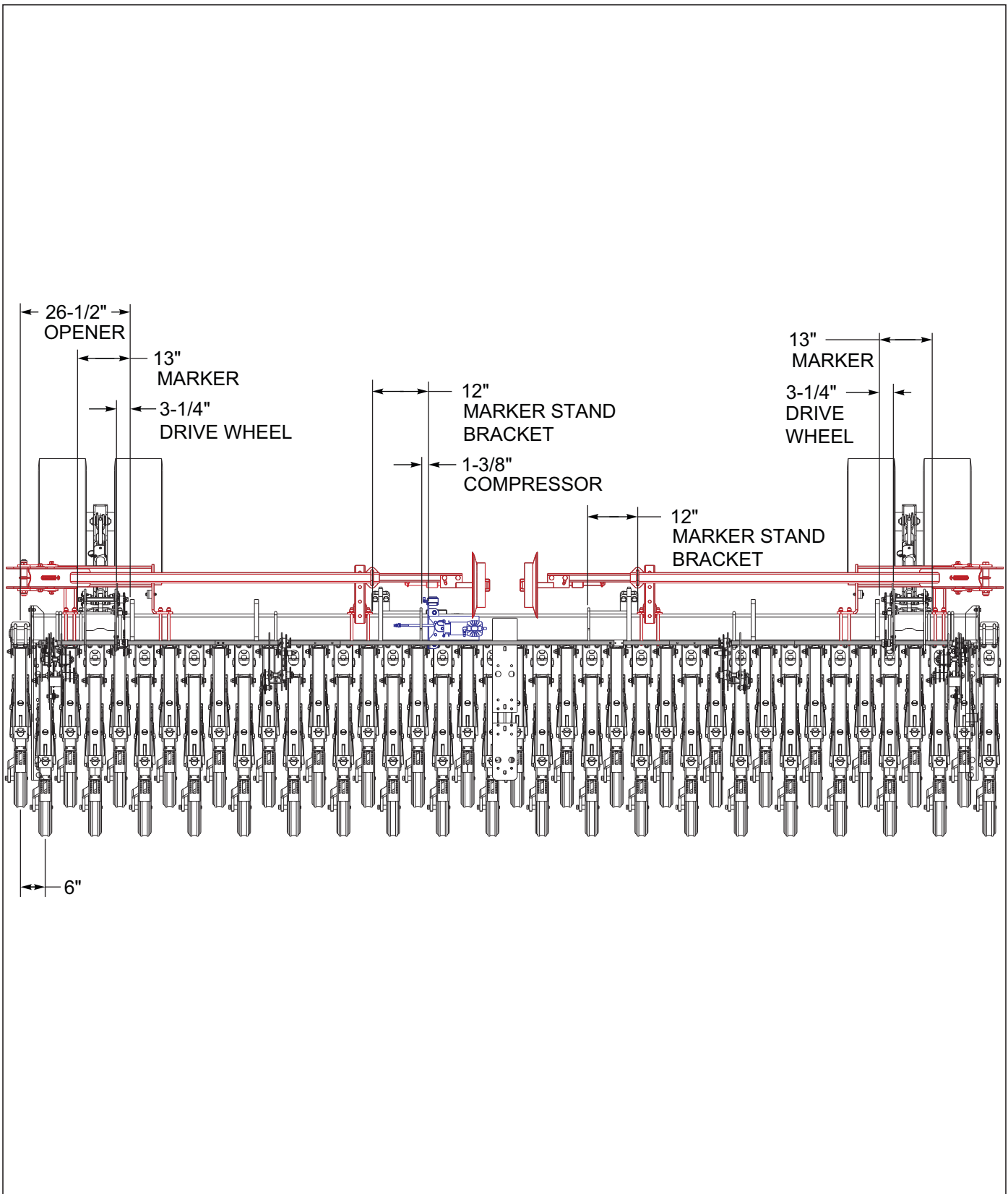

Figure 2-15: 5211-20' 6" Spacing Opener/Marker/Compressor Placement

# TABLE OF CONTENTS

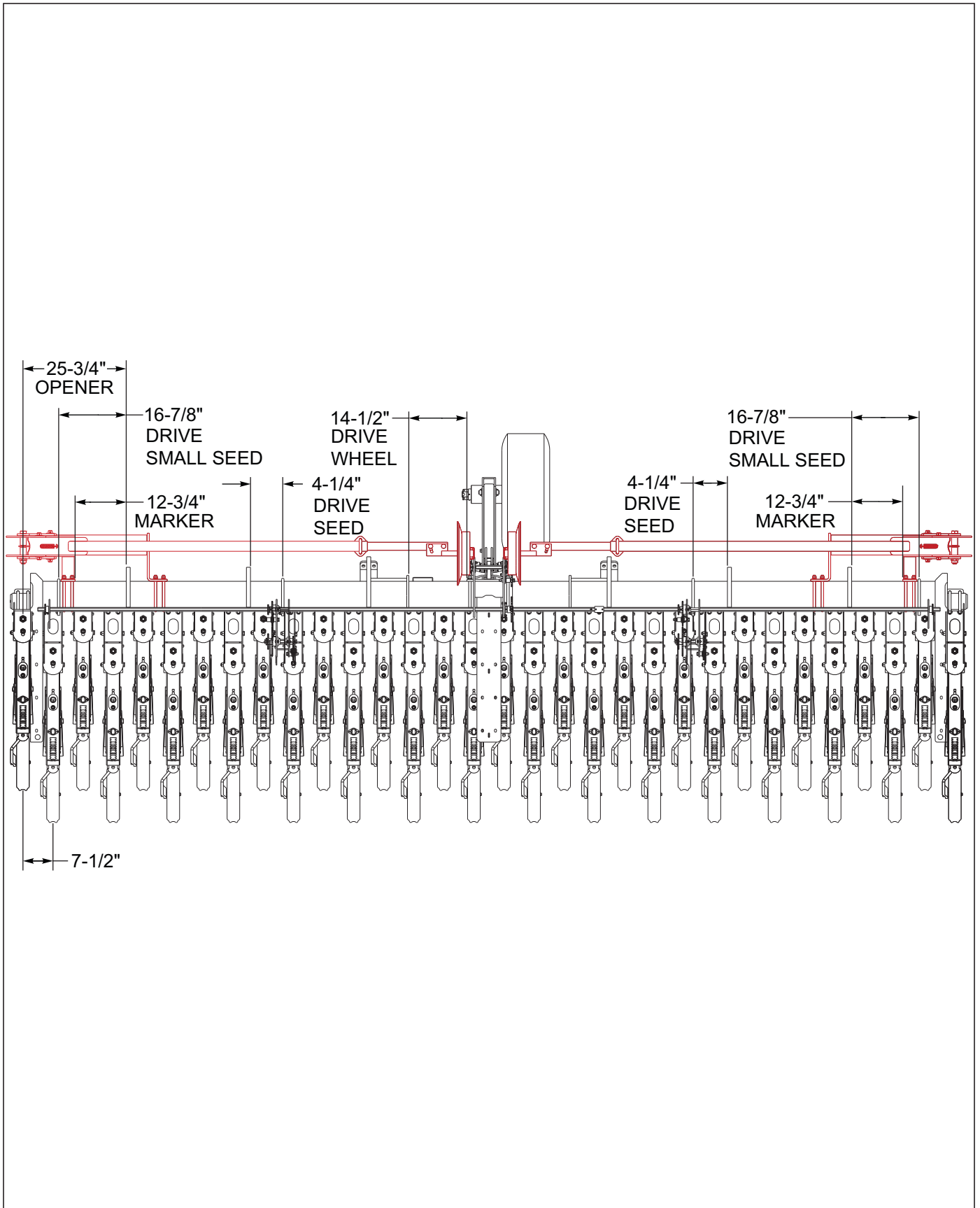

Figure 2-16: 5211-20' 7.5" Spacing Opener/Drive/Small Seed/Marker Placement

# TABLE OF CONTENTS

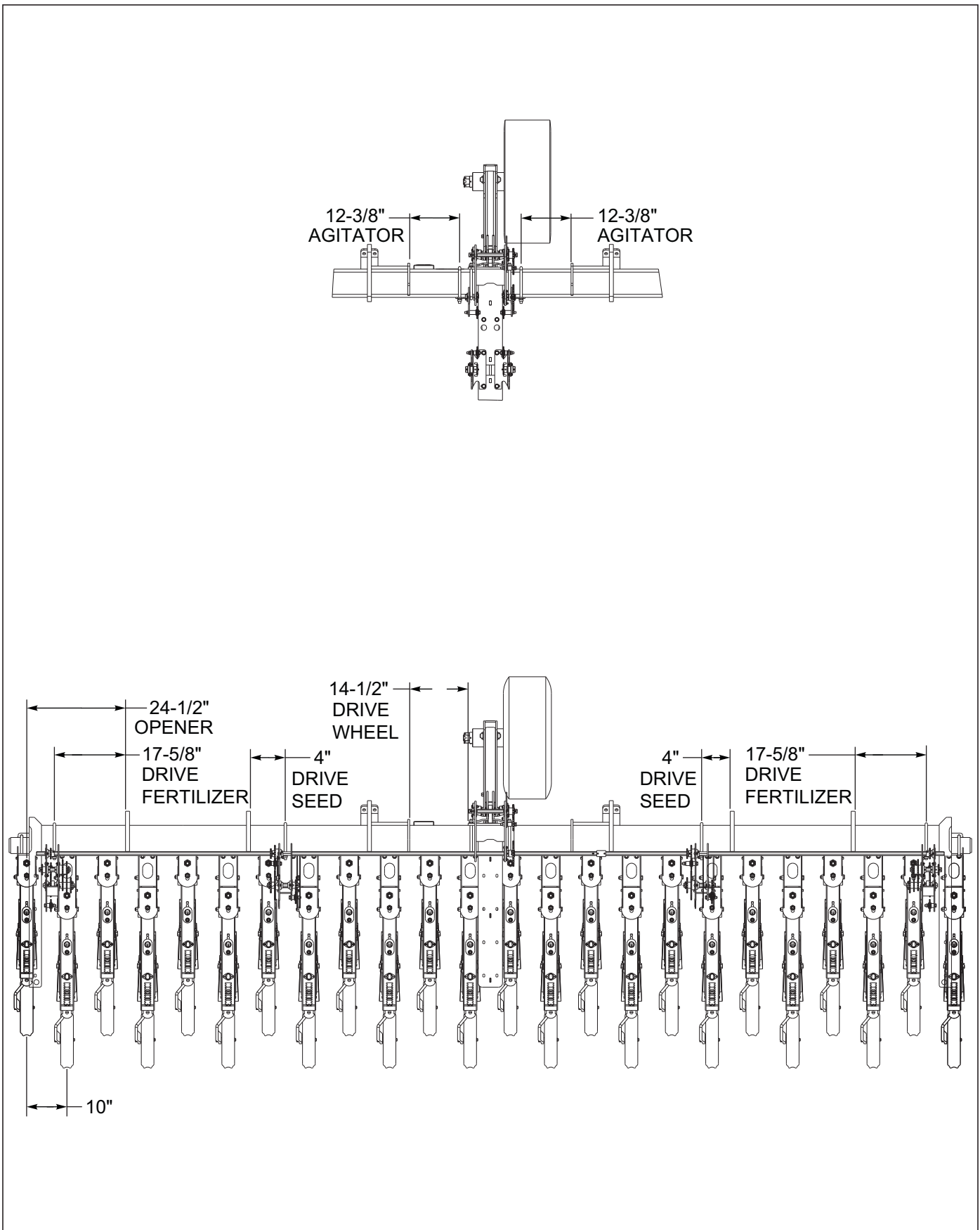

Figure 2-17: 5211-20' 10" Spacing Opener/Drive/Fertilizer/Agitator Placement

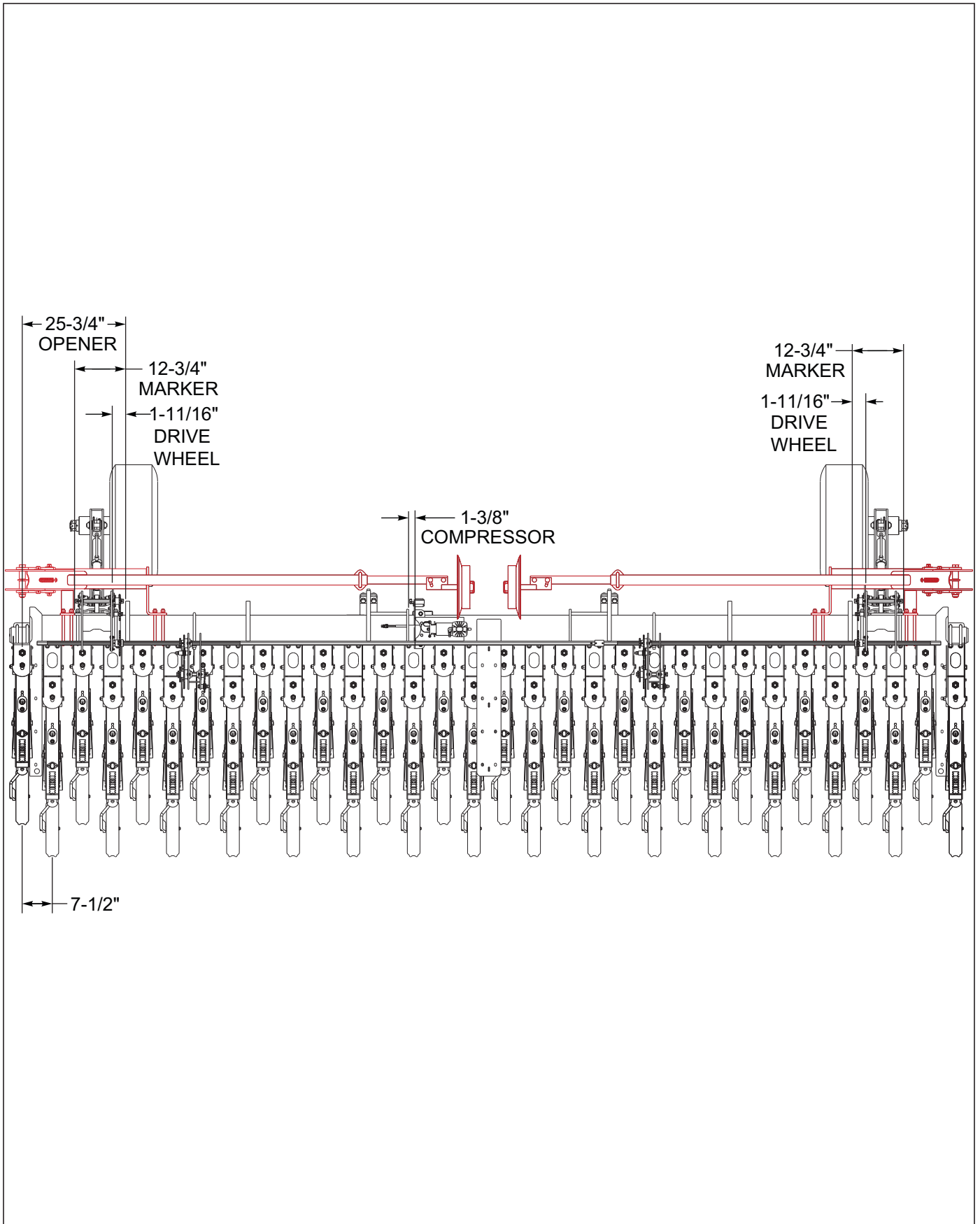
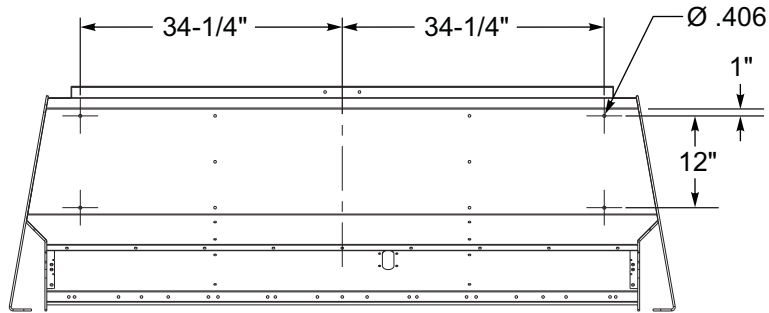
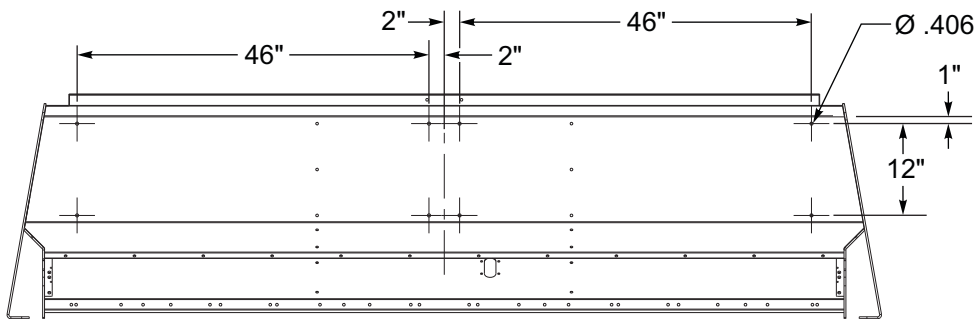

Figure 2-18: 5211-20' 7-1/2" 3-Point Opener/Drive/Marker Placement

# TABLE OF CONTENTS



7-1/2' SEED BOX P/N 154842



10' SEED BOX P/N 143932

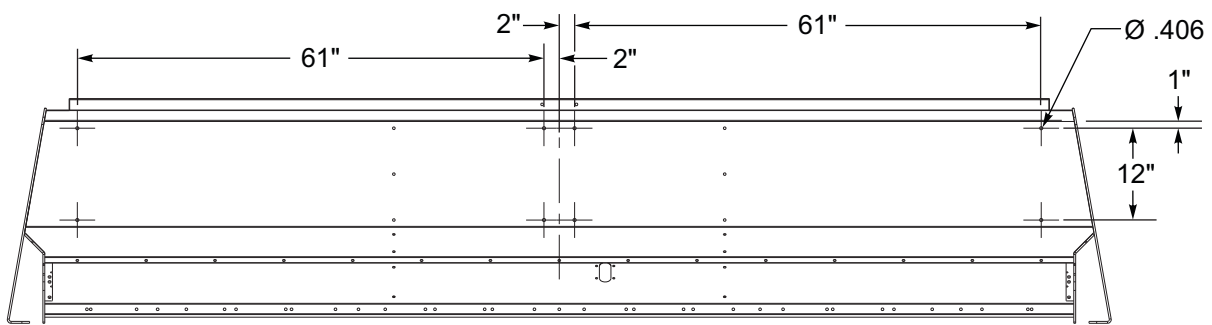

12-1/2' SEED BOX P/N 159102

Figure 2-19: Small Seed Attachment Drilling Placement

# Assembly Instructions

## Assembly Safety

Your new 5211 Grain Drill comes nearly completely assembled from the factory and ready to go to the field. This section includes press wheel and option assembly procedures.

To insure alignment of assemblies, **leave the nuts loose until completion** of final assembly. Use lock washers or flat washers as specified. Spread all cotter pins.

**After completion of final assembly, tighten all nuts evenly** to prevent misalignment, distortion or binding.

Tighten all screws and nuts to the recommended torques **Figure 2-4 on page 2-7.**

### DANGER

Opener blades are extremely sharp. Exercise extreme care when working on or near opener blades. Do not allow opener blades to roll over or fall onto any body part. Do not allow wrenches to slip when working near blades. Never push wrenches toward opener blades. Do not climb over machine above opener blades. Failure to stay clear of opener blade edges can cause serious personal injury or death.

### WARNING

Do not attempt to lift heavy parts (such as the frame, wheel lift, and pull hitch) manually. Use a hoist or a forklift to move these parts into position.

### DANGER

To prevent accidental lowering:

- All hydraulically elevated equipment must be locked out using the cylinder lockouts.
- Lower equipment to the ground while servicing or when it is idle.
- Failure to take measures to prevent accidental lowering may result in serious personal injury or death.

### CAUTION

Be sure to bleed the hydraulic system of all air in lines after installation. Failure to bleed the system of all air can result in improper machine operation.

## Rebounder Assembly

1. Attach rebounder mount bracket with 1/2 x 1-1/4 round head screw and 1/2 flange nut **See Figure 3-1.**
2. Attach rebounder orange with 1/4 x 1-1 hex screws and 1/4 flange nut.



**DANGER**

Opener blades are extremely sharp. Exercise extreme care when working on or near opener blades. Do not allow opener blades to roll over or fall onto any body part. Do not allow wrenches to slip when working near blades. Never push wrenches toward opener blades. Do not climb over machine above opener blades. Failure to stay clear of opener blade edges can cause serious personal injury or death.

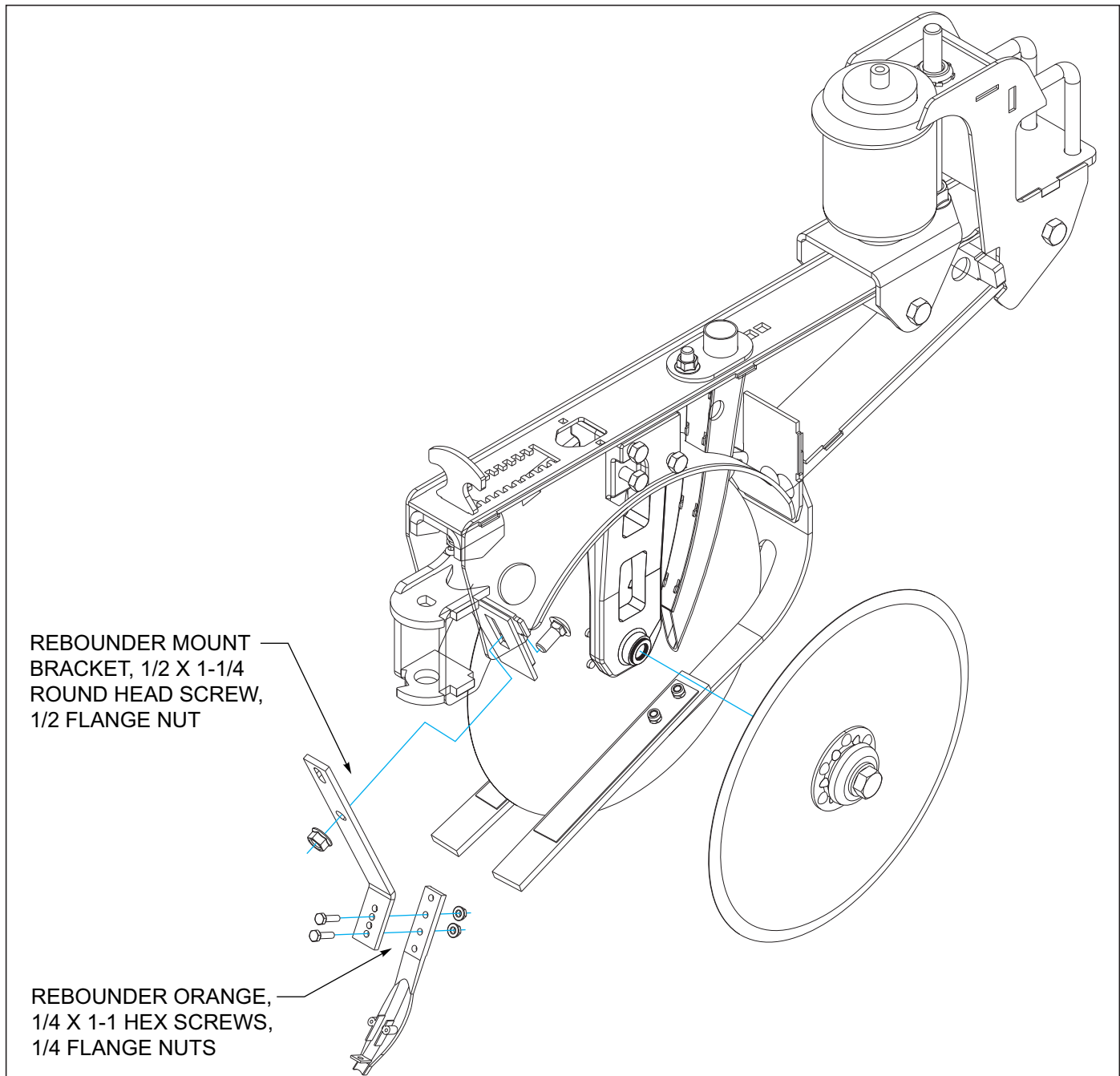

**Figure 3-1: Rebounder Assembly**

## Press Wheel Assembly

1. Attach each press wheel assembly to each air opener assembly on the Grain Drill using press wheel arm pin and 3/4 lock nut **See Figure 3-2.**
2. Attach each press wheel assembly to each spring opener assembly on the Grain Drill using press wheel with press wheel arm bushing, 5/8 x 4 bolt and 5/8 flange head nut **See Figure 3-3.**



**DANGER**

Opener blades are extremely sharp. Exercise extreme care when working on or near opener blades. Do not allow opener blades to roll over or fall onto any body part. Do not allow wrenches to slip when working near blades. Never push wrenches toward opener blades. Do not climb over machine above opener blades. Failure to stay clear of opener blade edges can cause serious personal injury or death.

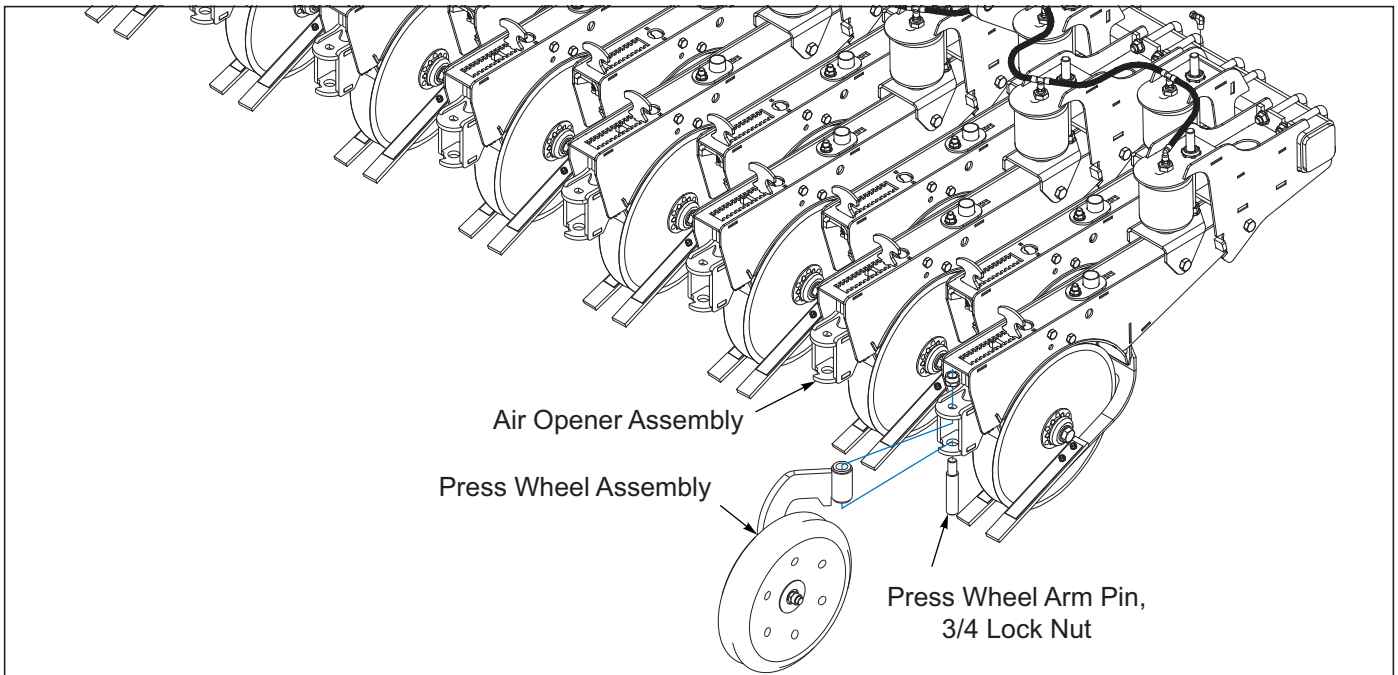

**Figure 3-2: Air Opener Press Wheel Assembly**

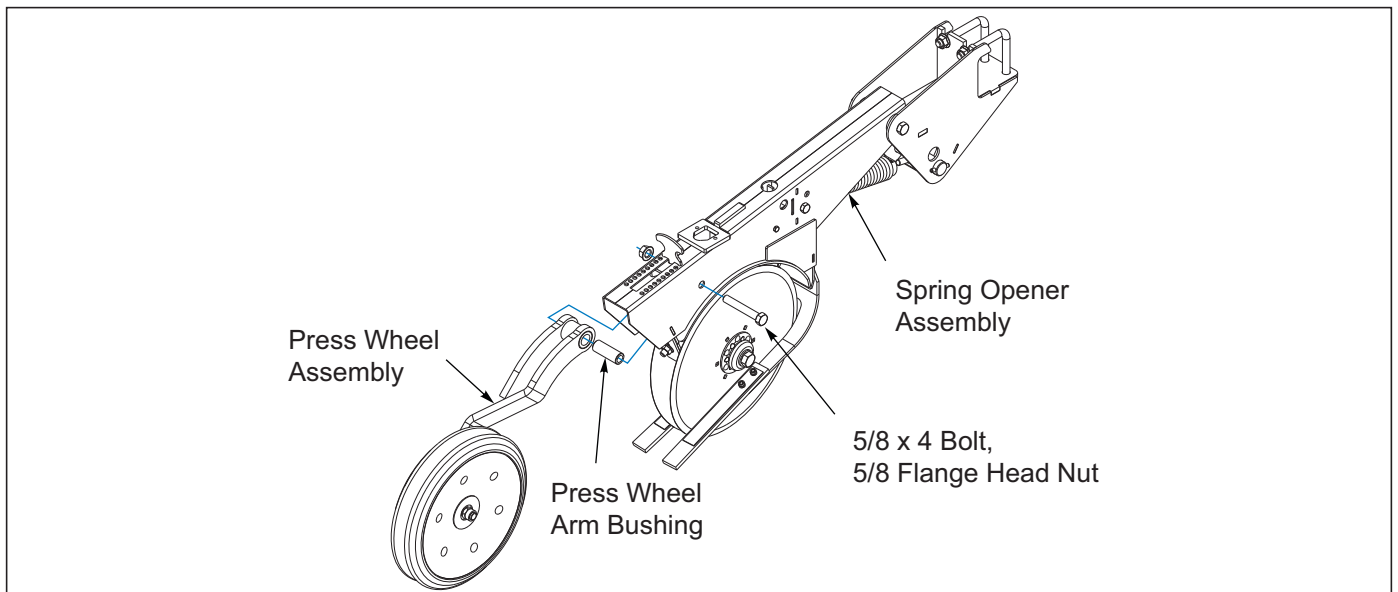

**Figure 3-3: Spring Opener Press Wheel Assembly**

## Small Seed Attachment Installation (Option)

**See Figures 3-6** for small seed attachment overview. Use these instructions to install the optional small seed attachment to the rear main seed box of the 5211 Grain Drill.

1. Attach the drill to the tractor and lower the unit to the ground. Leave the drill attached to the tractor while assembling the small seed attachment. This will prevent tipping of the drill.
2. Remove the SMV sign from the rear of the existing seed box. Reinstall the mounting screws in the seed box to plug the holes.
3. Determine whether the existing drill boxes have mounting holes for the small seed attachment. **See Figure 2-19**, for hole locations. If the mounting holes do not exist, these holes must be drilled in existing boxes before installing the attachment.
  - a. First locate and mark the center of the existing seed box along the top rear box edge. Base all dimensions from this mark.
  - b. Mark and center punch hole placement per drawing.
  - c. Using a 13/32" diameter drill bit, drill the mounting holes.
4. Remove the 3/8" hex lock nuts and 2-hole mounting plates from the front of the small seed box assembly **See Figure 3-6**.
5. Carefully raise the small seed attachment and insert the mounting screws through the holes drilled in the rear of the main seed box. Install the 2-hole mounting plates and 3/8" hex lock nuts on the inside of the main drill box to secure the small seed attachment.
6. Attach the chain wear pad to the seed box bracket with 3/8 x 1" hex screws and lock nuts in the forward set of mounting holes.

7. Remove the three outer locking nuts on the seed shaft bearing assembly. Slide the bearing assembly over the small seed square meter shaft. Insert the bearing assembly mounting screws into the small seed drive mount located on the end of the small seed box assembly. Loosely install the three locking nuts to hold the bearing assembly in place **See Figure 3-4**.

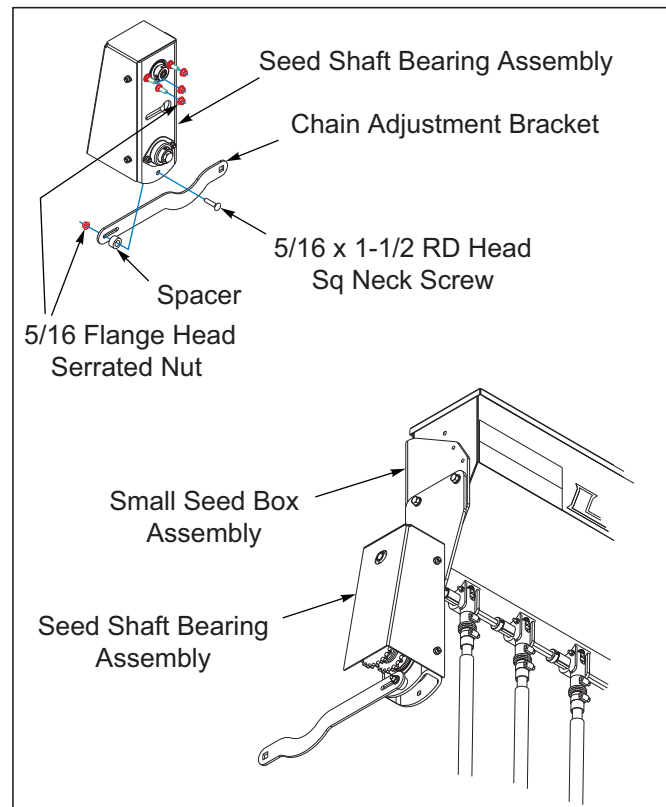

**Figure 3-4: Attaching Chain Adjustment Bracket to Small Seed Bearing Assembly**

8. Just in front of the small seed bearing assembly, remove the rear 1/2-13 x 1-1/4 hex head cap screw from the existing seed box bracket **See Figure 3-5**.

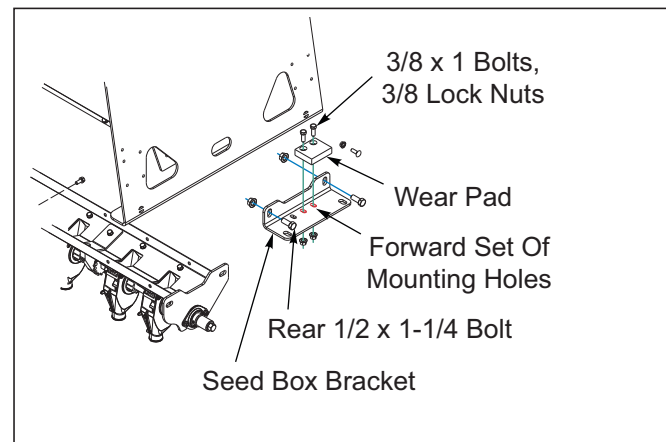

**Figure 3-5: Removal of Rear Screw from Existing Seed Box Bracket**

# TABLE OF CONTENTS

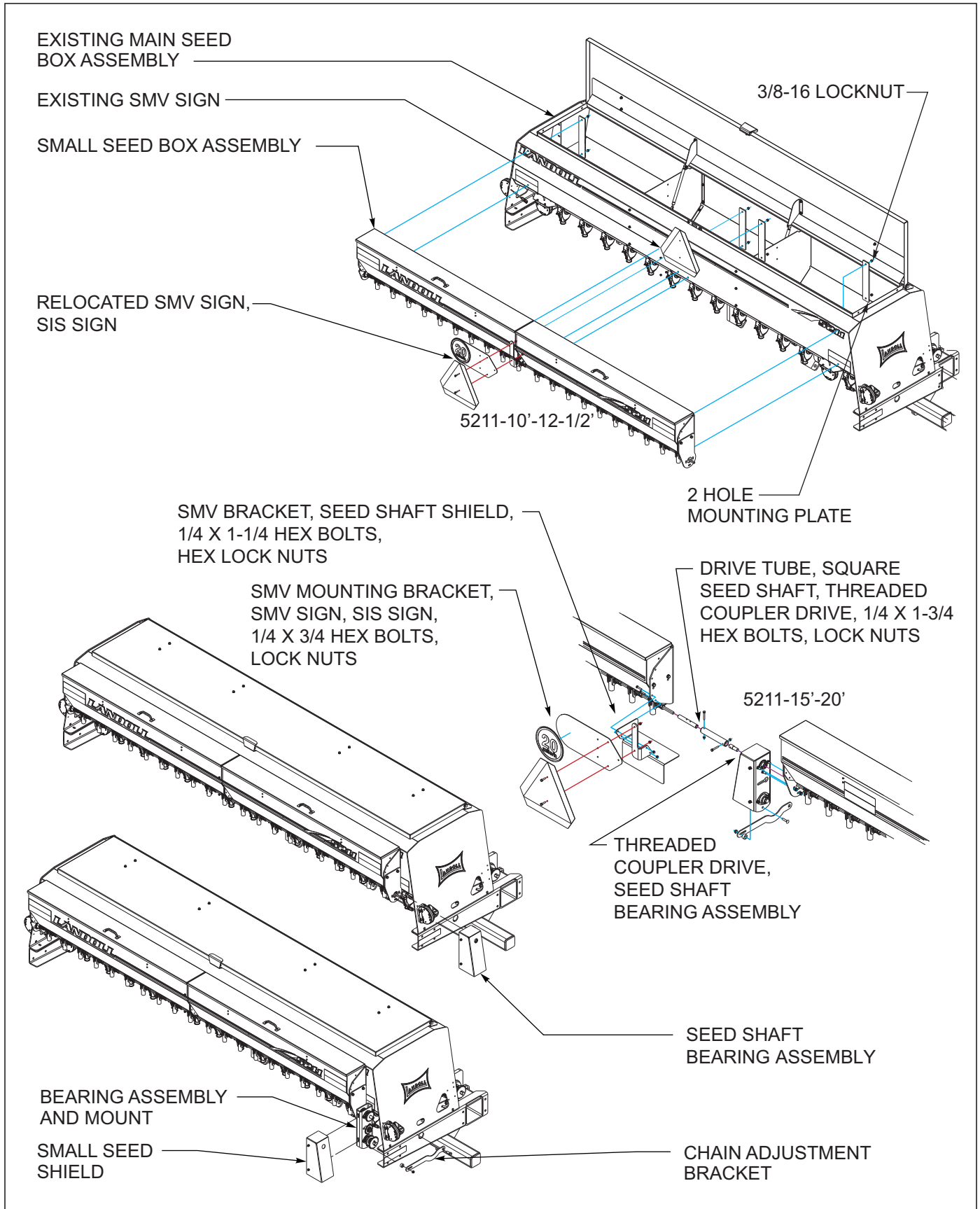

**Figure 3-6: Small Seed Assembly Overview (12-1/2' Drill Shown)**

9. Attach the front of the chain adjustment bracket to the seed box bracket with the 1/2-13 x 1-1/4 hex head cap screw.
10. Attach the slotted rear hole of the chain adjustment bracket to the outer hole of the small seed bearing assembly with a 5/16-18 x 1-1/2 round head square neck screw, 1" OD spacer and hex flange nut **See Figure 3-7.**

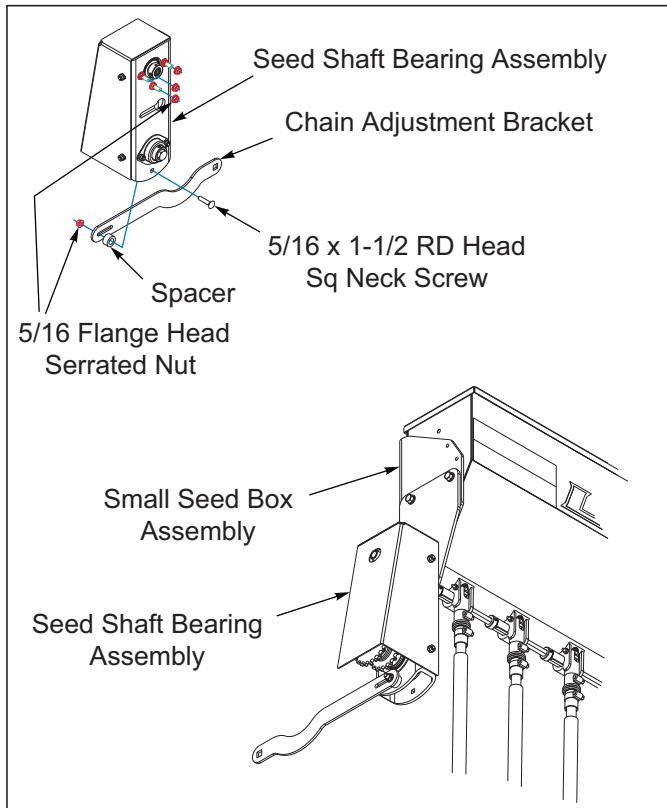

**Figure 3-7: Attaching Chain Adjustment Bracket to Small Seed Bearing Assembly**

11. Remove rear walkboard and right and left mounting brackets. Using existing screws, install new extended walkboard mounts to the rear of the drill frame. Reattach walkboard to new extended mounts.

**NOTE**

For 10' & 12-1/2' drills **See Figure 3-6** - If the drill has the optional dry fertilizer attachment, the grass seed bracket and bearing will not be used, **go to step 13.**

12. Remove existing 7/8 hex drive shaft above the drill 7 x 7 frame tube. Install the grass seed bracket and bearing to the rear of the main drill 7 x 7 frame. See **See Figure 2-14 for proper placement.** Reinstall the hex drive shaft, see placement dimensions.
13. Install the 24 tooth drive sprocket and locking set screw on the end of the hex drive shaft **See Figure 2-14 for proper placement.**

14. Remove the rear safety shield from the seed shaft bearing assembly. Loosen the rear mounting screws, then lift up and remove the shield and screws.
15. Install the connecting link in the roller chain, and install between the front 24 tooth drive sprocket and outer bearing on the seed shaft bearing assembly. Loosen the 5/16-18 flange head serrated nut through the chain adjustment bracket. Pull the lower end of the seed shaft bearing assembly rearward to tighten the drive chain. Retighten the 5/16-18 flange head serrated nut and the three hex lock nuts that attach the seed shaft bearing assembly to the mount on the end of the small seed box. Verify drive chain alignment, and adjust front 24 tooth sprocket if necessary.
16. Reinstall the safety shield over the seed shaft bearing assembly.
17. For 15' & 20' drills **See Figure 3-6** – Screw the threaded coupler drive into the open end of the seed shaft bearing assembly. Slide the square end of the drive tube over the square seed shaft of the left small seed box. Connect the drive tube and threaded coupler drive with the 6" shaft coupler using 1/4-20 x 1-3/4 hex head cap screws and hex lock nuts.
18. Install the SMV bracket and seed shaft shield, using 1/4 x 1-1/4 hex bolts and locknuts.
19. Install the metal small seed tubes in the mounting holes in each drill opener frame using 1/4-20 x 1 round head square neck screws and nuts. Note the lower end of the small seed tube points rearward towards the press wheels. The seed tube has two sets of mounting holes. Initially slide the seed tube forward. The tube may be positioned farther back for shallower planting depth if desired.
20. Attach the seed tube assemblies to the small seed box and small seed tubes on the opener.
21. Attach the SMV sign and SIS sign to the SMV mounting bracket with 1/4-20 x 3/4 hex head cap screws and hex lock nuts. Using 1/4-20 x 1-1/4 hex head cap screws and hex lock nuts, attach the SMV and bracket to the seed box mounting bracket extending below the small seed boxes in the center of the machine.



## Agitator Assembly (Option)

1. Install the right & left grass seed brackets 158309 & 158310 to the rear of the main drill frame 7 x 7 tube using u-bolts and 5/8 nuts. Attach the brackets 3-1/2"

from the seed box support as shown, *See Figure 3-8* for locations. 5211-10' uses the left bracket only, 5211-12-1/2' uses the right bracket only.

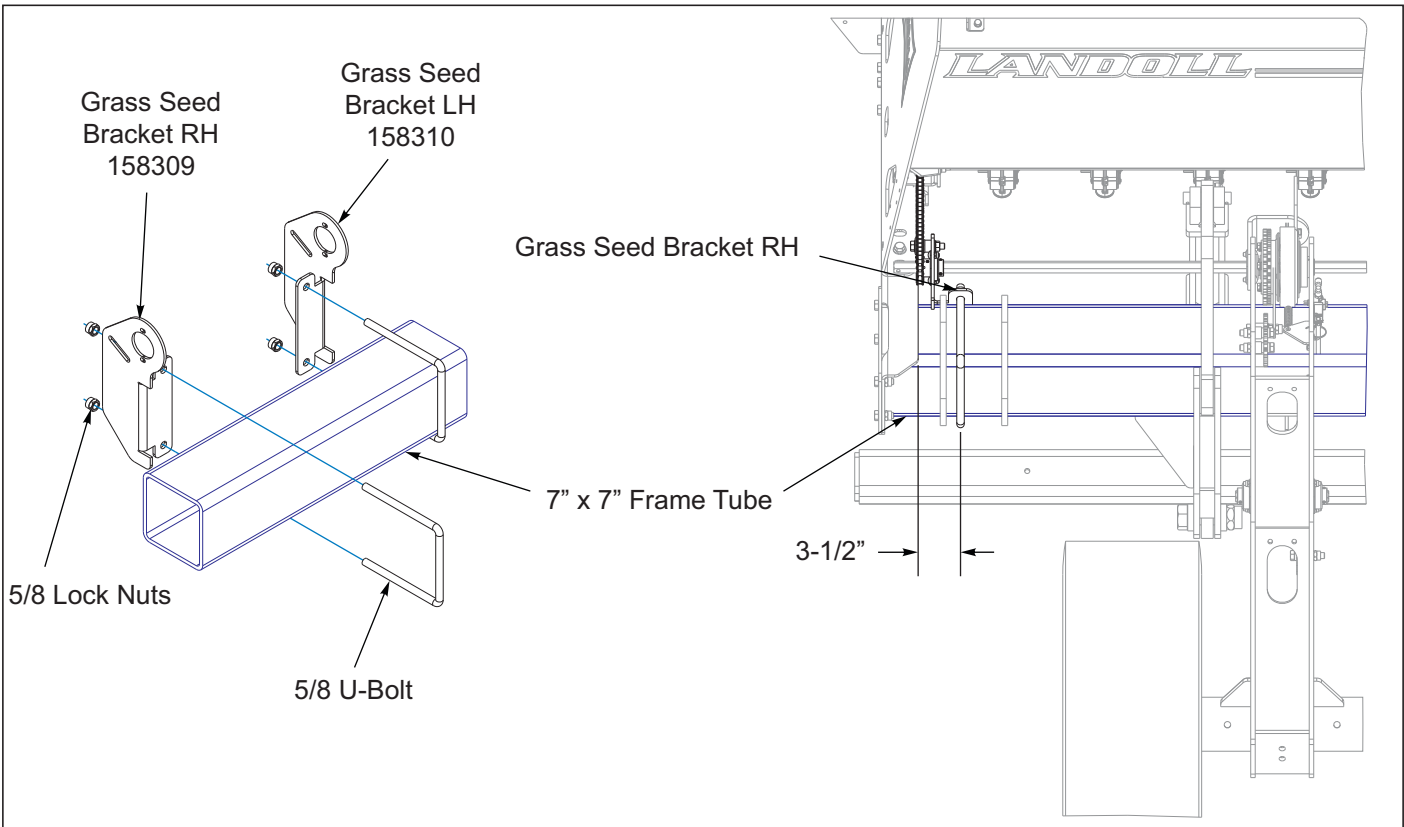

**Figure 3-8: Replacing the Existing Seed Box Bracket**

2. Remove the agitator hole covers inside of the seed boxes. *See Figure 3-9*. 5211-20' remove the two

inner covers only.

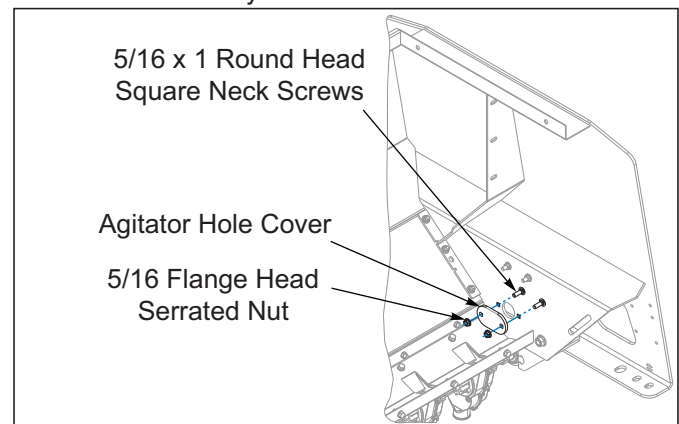

**Figure 3-9: Agitator Hole Covers**

3. Replace the 144127 seed box bracket, with the 168902 agitator bracket on the agitator drive sprocket ends of the seed boxes **See Figure 3-11**.
4. 5211-12-1/2' drill install one 85" hex shaft, 5211-20' drill install one 140" hex shaft.
5. 5211-15' drill install two new 85" long hex shaft above the 7 x 7 frame, from each end. Connect the two shafts together in the center of the drill with a hex coupler, 1/4 x 2 hex screws, and lock nuts.
6. Slide a 15-tooth hex bore sprocket over the outer drive end of each new hex shaft and secure with a 5/16 x 3/8 long set screw.
7. Attach the idler sprocket to the slotted hole in both grass seed brackets, using a 1/2 x 2-1/2 flange head screw, 1" spacer, idler sprocket, and locknut.
8. Install the plastic bearing into the small OD end of each bearing mount. Assemble the bearing mount w/bearing into each end of the drill seed box. The flange of the bearing mount will be on the inside of the drill box. Use 5/16 x 3/4 flange head screws and lock nuts.
9. Assemble a bearing mount w/bearing into the agitator shaft bearing bracket with 5/16 x 3/4 flange head screws. The flange will be on the opposite side of the agitator formed ears. This will be the center support for the square agitator shaft. This assembly will be approximately centered in the seed box between the meters. The holes will need to be drilled in the bottom of the seed box. Do not drill the holes until the rest of the agitator is assembled to be able to properly center the bearing **See Figure 3-10**.

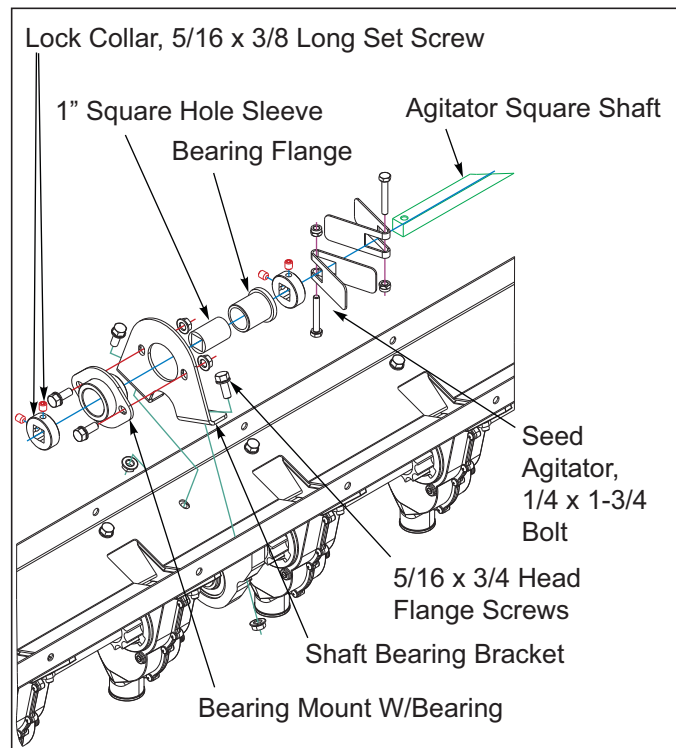

**Figure 3-10: Middle Bearing Mount Installation**

10. Install a 1" long square-holed sleeve in each bearing.
11. Insert the agitator square shaft through the outer seed box bearing, center agitator bracket and bearing, and inner seed box bearing. A lock collar is used on each side of each agitator bearing except the very outside of the box where the sprocket will attach.
12. Install the 15-tooth sprocket on the outer ends of each agitator shaft. Secure sprocket with a 1/4 x 1-1/2 spring pin.
13. Starting from the outside, slide the sprocket against the agitator bearing **See Figure 3-11**. Slide the lock collars against each side of the agitator bearings and tighten. Make sure the agitator shaft will rotate freely and not bind.
14. Install two seed agitators over each seed meter opening using 1/4 x 1-3/4 hex screws and lock nuts **See Figure 3-12**. Agitators should be installed on opposite sides of the agitator shaft. Make sure the shafts will turn freely and not bind or catch on anything after assembly.
15. Install an idler sprocket, 17/32 spacer, (3) flat washers, 1/2 x 3 screw, and locknut in the front seed box bracket hole **See Figure 3-11**.

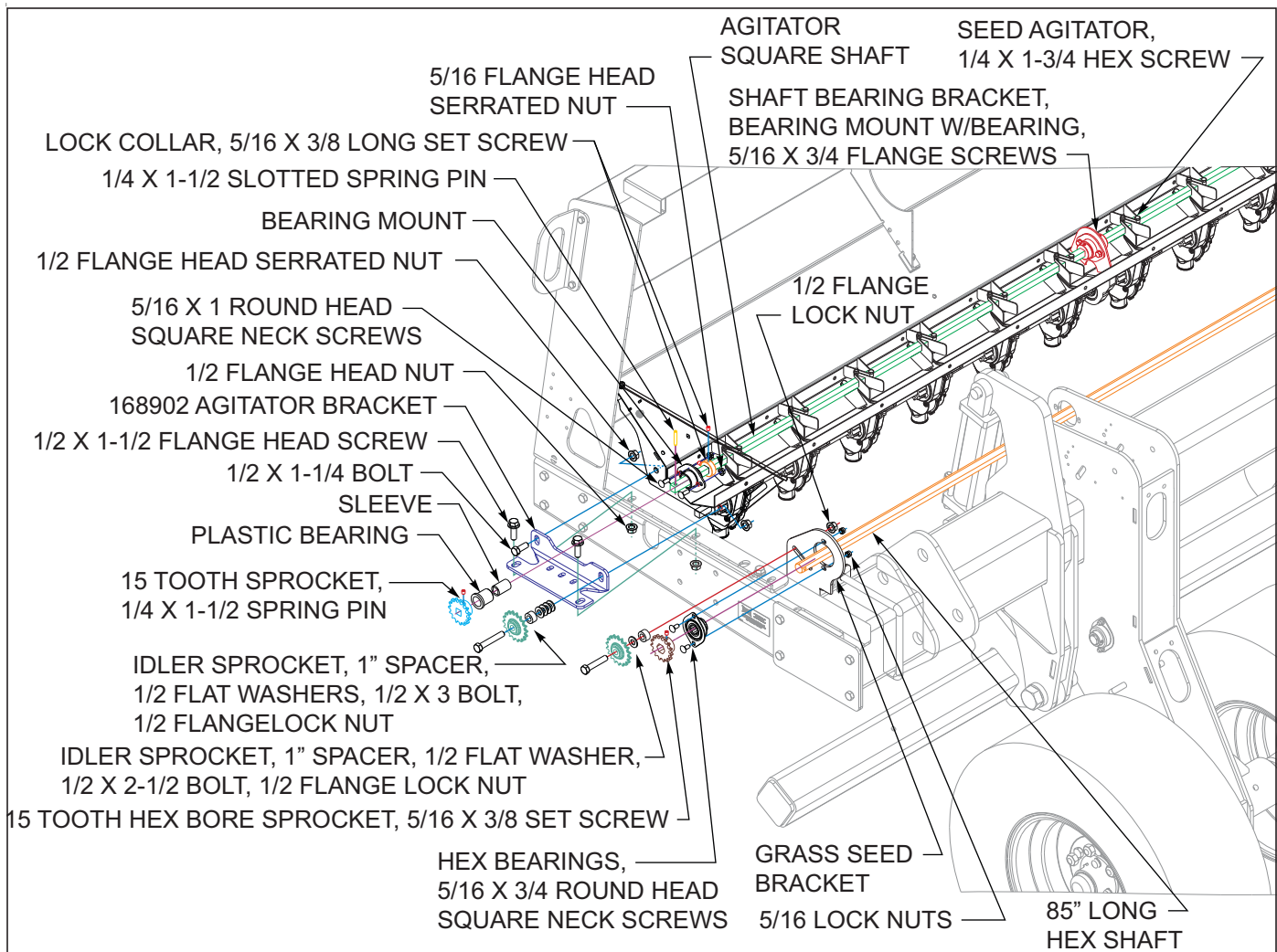

**Figure 3-11: Right & Left Grass Seed Brackets**

16. Locate and center the middle agitator bearing bracket between the center two seed meter openings. Mark and drill 11/32" holes in the seed meter bottom to secure the agitator bracket. Use 5/16 x 3/4 flange

screws and lock nuts to fasten the agitator bracket.

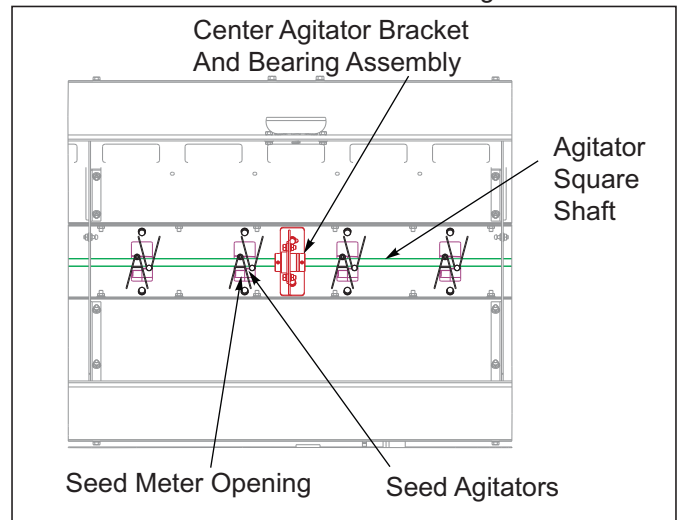
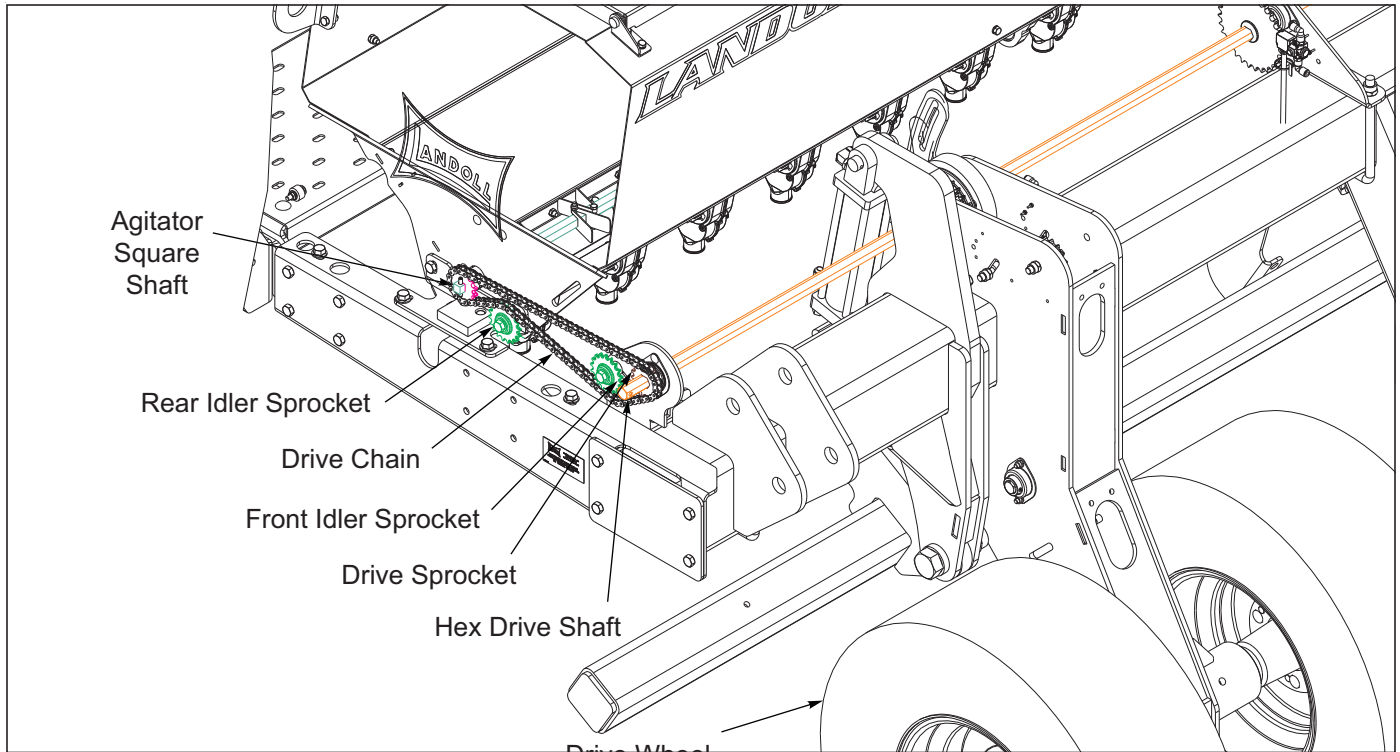

**Figure 3-12: Middle Agitator Bracket**

17. Route the drive chain around the agitator shaft and to the front hex drive shaft as shown [See Figure 3-13](#). Adjust the chain tension with the front idler sprocket. Adjust the drive and idler sprockets as necessary to make sure the chain and sprockets are

in-line.

18. Verify that the agitator sprockets and chain is in-line. Rotate the drive wheel to verify that the drive chains are in-line and not binding.



**Figure 3-13: Agitator Drive Chain Assembly**

19. If the drill seed boxes have a float type seed level indicator, install the new shorter seed level indicator rod [See Figure 3-14](#). Otherwise the agitators will interfere with the indicator when the seed level is low.

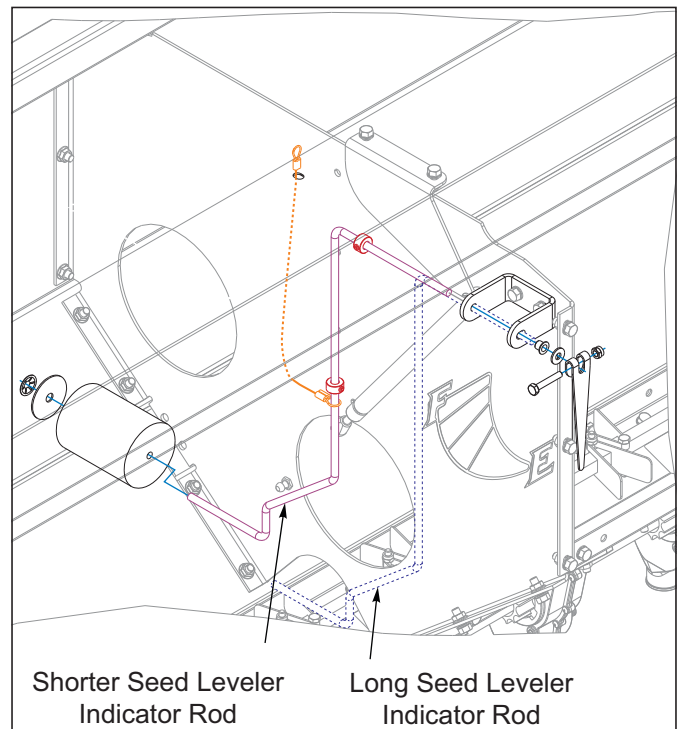

**Figure 3-14: Seed Box Seed Level Rod Installation**

## 5211 Hydraulic Marker Installation (Optional)

The 5211 grain drill may be equipped with optional hydraulic markers.



### CAUTION

Please read the grain drill operator's manual before attempting to install, operate, or service the hydraulic markers.



### WARNING

Do not attempt to lift heavy parts (such as the frame, wheel lift, and pull hitch) manually. Use a hoist or a forklift to move these parts into position.



### DANGER

To prevent accidental lowering:

- All hydraulically elevated equipment must be locked out using the cylinder lockouts.
- Lower equipment to the ground while servicing or when it is idle.
- Failure to take measures to prevent accidental lowering may result in serious personal injury or death.



### CAUTION

Be sure to bleed the hydraulic system of all air in lines after installation. Failure to bleed the system of all air can result in improper machine operation.



### CAUTION

Marker blades are very sharp, use gloves when working around marker blades.



### WARNING

Escaping hydraulic fluid can cause serious personnel injury. Relieve system pressure before repairing, adjusting, or disconnecting. Wear proper hand and eye protection when searching for leaks. Use cardboard instead of hands *See Figure 4-11* Keep all components (cylinders, hoses, fittings, etc.) in good repair.



### DANGER

To prevent injury or death, stay clear of markers while folding/unfolding. Hydraulic failure can allow markers to raise or fall suddenly.



### DANGER

To prevent injury or death from electrocution: stay away from power lines while transporting, folding, or unfolding markers. Electrocution can occur without direct contact of power lines.

1. Attach the grain drill to the tractor on a large level area large enough to unfold the markers. Make sure there are no overhead electrical wires or other obstructions that would interfere with the marker travel.
2. Remove the drill cylinder lockouts and lower the drill to the ground to relieve any hydraulic pressure.
3. **For pull type drills** – attach the marker valve mount bracket to the top of the hydraulic manifold at the rear of the hitch using the same manifold screws and nuts. **For 3pt drills** - the bracket will attach to the top of the 3pt mount with 1/2x1-1/2 screws and locknuts.
4. Attach the marker sequence valve to the top of the valve mount bracket with 3/8x1 screw and lock washers. The A1 and B1 ports should face the front of the drill.
5. Connect 90° swivel fittings to all six open ports on the marker valve.
6. Wearing safety glasses – blow compressed air through each of the hydraulic hoses before installation to make sure there is no moisture or other contaminants that may have entered the hoses.
7. **Pull-type hitches** – Using a long fish tape or wire, insert through the large oval opening in the front of the hitch, through the left side of the hitch, and out the opening in the rear of the hitch tube. Pull the long marker hoses through the hitch. O-ring end of the hoses will be at the front of the drill. Connect the hoses to the A1 & B1 ports of the marker sequence valve. **3pt drills** – connect the lead hoses to the A1 &

- B1 ports on the front of the marker sequence valve.
8. Install the male couplers on the front of the marker hoses.
  9. Wrap the marker hoses with the black hose wrap approximately 12 inches behind the couplers to pair and identify the marker hoses.
  10. See the following pages for the marker placement dimensions [2-10 through 2-18](#).
  11. Carefully lift and attach the right and left marker assemblies to the front side of the 7x7 drill frame tube using u-bolts and 5/8 nuts provided.



### CAUTION

There is no oil in the cylinders, so marker assemblies may move. Use caution when handling around pinch points.

12. Install (black) restricted 90° fittings in the rod end of each marker cylinder.
13. Install 45° fittings in the base end of each marker cylinder.
14. Connect the marker cylinder hoses from the marker sequence valve to the marker cylinders.

### NOTE

**“C” ports on the marker valve must connect to the rod end of each marker cylinder. “R” ports on the marker valve must connect to the base end of each marker cylinder.**

15. Route the hoses over the top of the hitch and along the top of the 7x7 frame to the marker cylinders. Cylinder hoses must have enough slack to move through the fold cycle. Hose clamps are provided to secure the hoses to the marker mount.
16. Install the yellow reflectors to the outer front of each marker mount [See Figure 3-15](#).

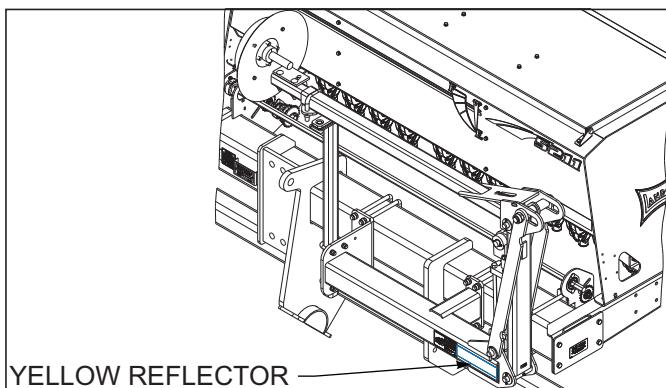

**Figure 3-15: Yellow Reflector**

17. Install the “Danger – Electrocution” decals to the front of the marker mounts next to the yellow reflectors [See Figure 3-16](#).

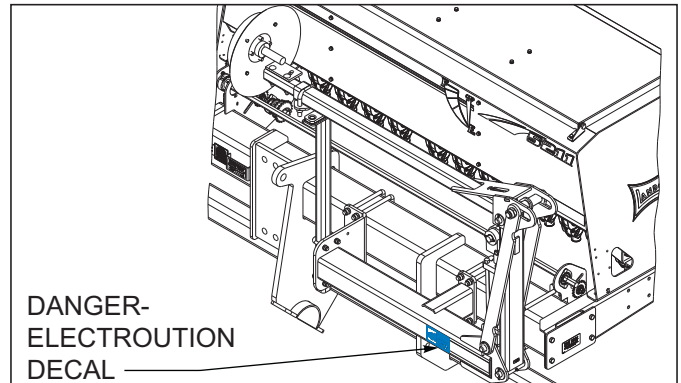

**Figure 3-16: Danger - Electrocution Decal**

18. Adjust the marker support stands if necessary to support the markers when folded. Markers should be flat and parallel with the marker frame.
19. [See “Hydraulic Row Markers \(Option\)” on page 4-32](#). Marker hoses are not filled with oil and will need purged of air before attempting to fold/unfold the markers or the markers will fall. Unpin the rod end of the marker cylinders. Make sure the rod end is clear to fully extend and retract without contacting any other parts. Check that tractor is full of the manufacturers recommended hydraulic oil. Connect the marker hoses to the tractor. Slowly extend and retract the marker cylinders several times until the cylinder movement is positive and immediately responsive. Do not loosen or crack any hydraulic fittings or lines. Reconnect the rod end of the marker cylinders.
20. Cycle the marker hydraulics to verify operation. With both markers raised, slowly engage the hydraulics. One marker should lower. Reversing the hydraulic lever will raise that marker. Slowly engage the marker hydraulics again and the opposite marker will lower.
21. If the markers do not function correctly:
  - Verify that the tractor is fully of the recommended hydraulic oil.
  - Continue to cycle the markers several times to purge any remaining air in the system.
  - Recheck hydraulic plumbing, for proper marker valve and cylinders connections.
  - Switch to a different tractor remote.
22. See Marker Disc Adjustment – adjust marker disc angle to the desired cutting width. Adjust the outer marker arm for the desired cutting width.
23. Check all screws, fittings, hoses, and pins to make sure connections are tight and secure. Verify that the hydraulic hoses are not pinched or twisted.



 **DANGER**

Never allow anyone to ride on the 5211 Grain Drill at any time. Allowing a person to ride on the machine can inflict serious personal injury or death to that person.

 **DANGER**

Install lift cylinder lockouts before transporting. Failure to lockout the cylinders can cause the unit to settle during transport which can result in serious injury or death and cause equipment damage.

 **DANGER**

Opener blades are extremely sharp. Exercise extreme care when working on or near opener blades. Do not allow opener blades to roll over or fall onto any body part. Do not allow wrenches to slip when working near blades. Never push wrenches toward opener blades. Do not climb over machine above opener blades. Failure to stay clear of opener blade edges can cause serious personal injury or death.

 **CAUTION**

When transporting farm implements on public roads, it is the responsibility of the operator to abide by state and local laws concerning wide loads, speed, safety emblems and safety lighting equipment. Drive at safe speeds, particularly when rounding corners, crossing rough ground or driving on hillsides, to prevent tipping the tractor.

 **WARNING**

Lower elevated components or install cylinder lockouts and pins before servicing or when equipment is idle. Failure to take preventive measures against accidental lowering can result in serious personal injury.

 **CAUTION**

Relieve system air pressure before attempting to adjust or service any air spring component. Make sure all components are in place and secure before charging the system.

 **DANGER**

Keep all bystanders away from the machine when folding/unfolding markers, raising/lowering openers, and transporting.

 **DANGER**

To prevent injury or death from electrocution: stay away from power lines while transporting, folding, or unfolding markers. Electrocution can occur without direct contact of power lines.

 **DANGER**

Always lock the tractor drawbar in the center position when transporting the unit. Failure to do so can result in serious injury or death and cause damage to the machine.

## **5211 Operation Checklist**

This section is a checklist for general operating procedures. Refer to individual sections for further details on safety, settings, and proper procedures.

### **Initial Checklist**

1. Read and understand the operating manual and all Safety Information.
2. Attach the grain drill to the tractor with proper pin and safety chain.
3. Check all the tires for proper inflation and all lug nuts for proper torque.
4. Lubricate the drill at all points listed.
5. Check all bolts and fasteners to verify they are not loose.
6. Replace or repair any damaged or worn parts.
7. Inspect all hydraulic cylinders, fittings and hoses for leaks and repair before going to the field.
8. Check drive chains for wear and proper tension.
9. Check air system and verify system holds and maintains pressure. Locate and repair any leaking airlines, fittings, or air springs.
10. Clean seed boxes of any old seed or residue.
11. Verify all seed hoses are connected and not ripped, torn, or sagging.
12. Check opener blades for wear and proper pinch point.
13. Rotate drive wheels to verify all shafts and chains turn freely.
14. Turn on seed monitor and verify there are no errors.

### **Field Checklist**

1. Check all hydraulic and electrical connections. Keep hoses and wires above hitch pin and free from 3PT hitch.
2. Turn on the air compressor and verify operation.
3. Raise the openers, then check and adjust system air pressure.
4. Adjust seed gate to desired setting and verify all gates are set the same.
5. Adjust seeding rate to the desired setting for all sections.
6. Adjust the seed drive setting to the same type for all sections.
7. Adjust the dry fertilizer drive to desired setting for all sections.
8. Adjust the small seed rate to the desired setting for all sections.
9. Calibrate the seed and fertilizer settings.
10. Adjust all press wheels to the desired settings for all sections.
11. Adjust monitor to desired settings and limits, width, spacing, acres, etc.

### **Field Operation**

Never allow anyone to ride on the grain drill, stay clear of moving parts.

Raise the drill when turning. Avoid backing up to prevent plugging and equipment damage.

Stay away from power lines during operation when folding or unfolding the drill and markers. Electrocutation can occur without direct contact.

Do not transport the drill full of seed and fertilizer.

1. Stop the drill.
2. Remove lift cylinder lockouts (pull hitch).
3. Completely lower drill.
4. Fill the drill with desired seed and fertilizer and close all lids.
5. Begin planting, pull forward and lower the drill.
6. After pulling a short distance, stop the drill. Verify all openers are planting, seed depth and placement is correct, sufficient weight on the press wheels. Make any adjustments and resume planting.

### **Planting Completion**

1. Stop the drill on a large level area.
2. Fold markers.
3. Fully raise the drill.
4. Install lift cylinder lockouts.
5. Remove any unused seed and fertilizer from the drill after planting season.

## Tractor Preparation

The Landoll 5211 Grain Drill is designed to be pulled by tractor equipped with a double lip or clevis type hitch. If your tractor is not equipped as such, you need to purchase the hitch from your local tractor dealer.

Before attaching the Grain Drill, prepare the tractor as follows:

1. Inflate the rear tractor tires equally and add ballast according to the tractor operator's manual.
2. Lock the tractor drawbar in the center position.

## Grain Drill Preparation

1. Prior to operating the 5211 Grain Drill, read and understand the operator's manual and all decals.
2. Inspect the machine thoroughly for good operating condition.
3. Replace worn or missing parts.
4. When the machine is new, check the bolt tightness after a few hours of operation. Tighten any loose nuts or bolts. Check the lift wheel lug bolts daily.
5. Check the lift wheel tire inflation. Inflate all tires equally to avoid side draft. Follow the tire manufacturer's recommended pressures listed on the sidewall of the tires.
6. Check opener scrapers for proper adjustment to the disc blades *See "Air System Pressure" on page 4-8.*
7. Lubricate the machine *See "Storage" on page 5-6. and Figure 5-4 on page 5-5.*
8. Check that all safety decals, lights and reflectors are correctly located and legible. Replace if damaged.

## Attaching Grain Drill To The Tractor



### WARNING

**The Grain Drill can have positive and negative tongue weight. Use a locking-style hitch pin that is properly sized for the tractor drawbar and implement hitch.**

1. Make sure the tractor drawbar is rated and adjusted properly for the weight of the drill hitch.
2. Measure the tractor drawbar and adjust the hitch clevis to the appropriate hitch mounting holes.
3. Carefully back the tractor into position. If the draw bar is too high or too low, adjust hitch height using tongue jack.

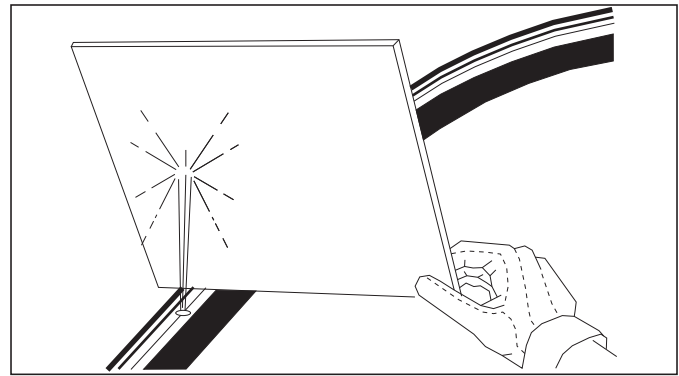

**Figure 4-1: Hydraulic Leak Detection**



### WARNING

**Escaping fluid under pressure can penetrate the skin causing serious personnel injury. Avoid the hazard by relieving system pressure before disconnecting hydraulic lines. Tighten all connections before applying pressure. Keep hands and body away from pinholes which eject fluid under high pressure. Wear protective gloves and safety glasses when working with hydraulics. Use a piece of cardboard or paper, not body parts to search/check for leaks *See Figure 4-1.* If an accident occurs, see a doctor immediately. Any fluid injected into the skin must be surgically removed within a few hours or gangrene may result.**

4. Back the tractor into final position, and install the hitch pin.
5. Connect the lift and marker hoses to the tractor.
6. Plug the safety lights into the seven-pin connector on the tractor.
7. Attach the safety chain to an anchor on the tractor sufficient to pull the drill. Refer to tractor manual for proper placement.
8. Fully raise the drill and install the transport locks.
9. Rotate the parking jack stand into storage position and pin in place. Remove the tongue jack and place in storage position.

## Lockouts - Pull Hitch

1. Transport lock pins are provided to secure the Grain Drill in raised position. Do not depend on hydraulics when working beneath raised equipment or when transporting.



### WARNING

Install cylinder lock pins before attempting to service, adjust, or transport raised equipment.

2. The lockouts are installed on the holders located on the hitch when not in use *See Figure 4-2*. To install the transport locks:
  - a. The hitch clevis must be attached to the tractor. Then fully raise the main lift of the Grain Drill.

- b. Remove the L-pins and hairpin clips from the stored lockouts.
- c. Slide the transport locks over the extended cylinder shafts.
- d. Reinstall the L-pins and hairpin clips to secure the transport locks to the cylinder shafts.
- e. Unpin the rear jack stands and rotate into storage position.

### IMPORTANT

Failure to install/remove **BOTH** lockouts will result in damage to the grain drill.

6. To remove the lockouts *See Figure 4-2*:
  - a. Fully raise the Grain Drill to remove any weight setting on the transport locks.
  - b. Remove the L-pins, hairpin clips, and transport locks from both cylinder shafts.
  - c. Return the lockouts, L-pins, and hairpin clips to the storage locations on the hitch.

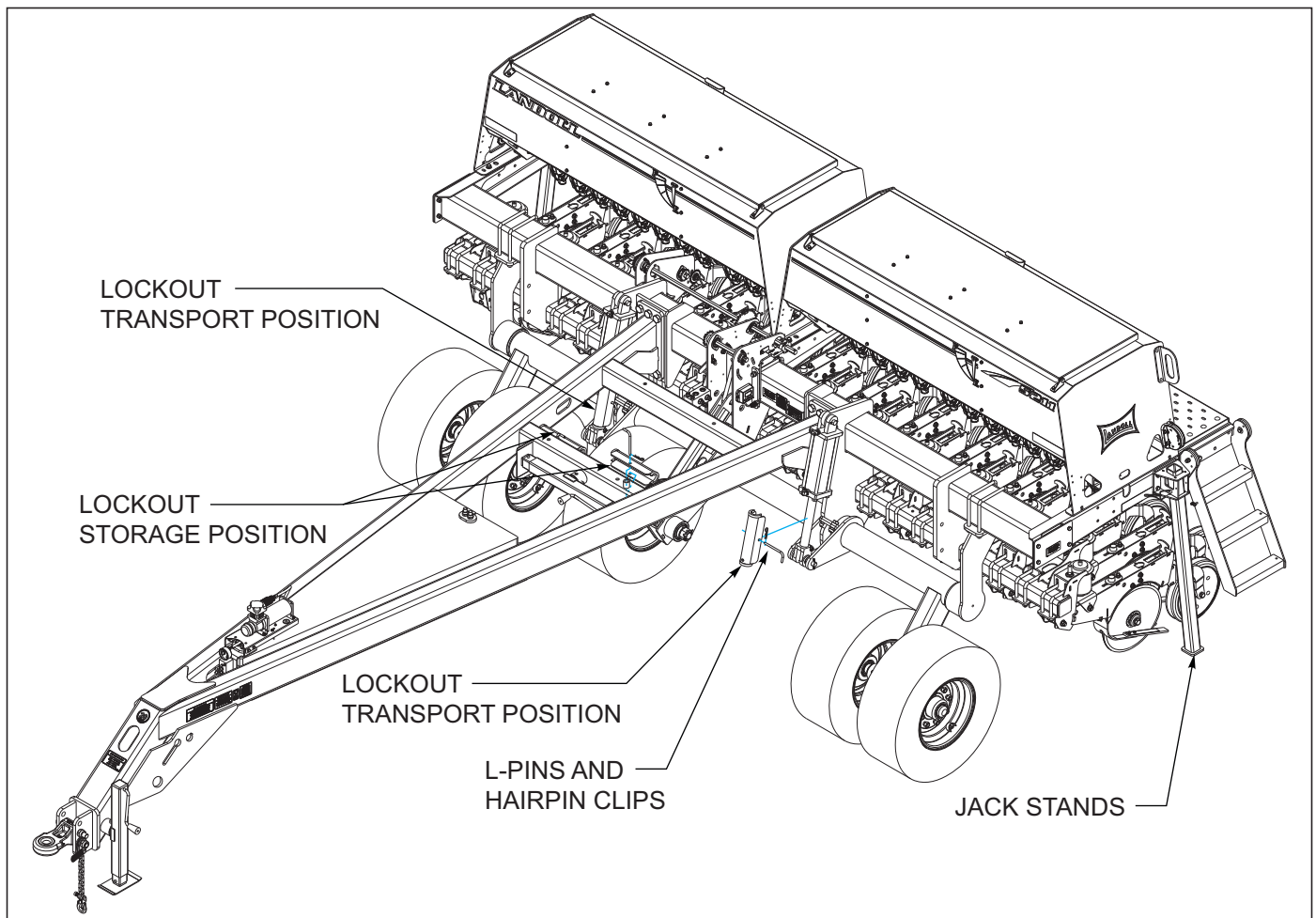

**Figure 4-2: Storage & Transport Position of Lockouts**

## Leveling the Hitch Clevis

1. The hitch clevis height should be adjusted to match the drawbar height of the tractor. This will allow the hitch to operate through its most efficient range and level throughout the field *See Figure 4-3*.
2. On a level surface, measure from the ground to the top side of the tractor drawbar. For drawbar heights 18" or lower use the lower hitch clevis holes. For drawbars 20" tall use the middle hitch clevis holes, and for 22" or greater use the top mounting holes.
3. To change the hitch clevis mounting holes, the drill should be unhitched from the tractor. Make sure the air openers are charged with air (50 psi min). Lower the drill to the ground, install the tongue jack. This will remove any hitch weight from the hitch clevis.

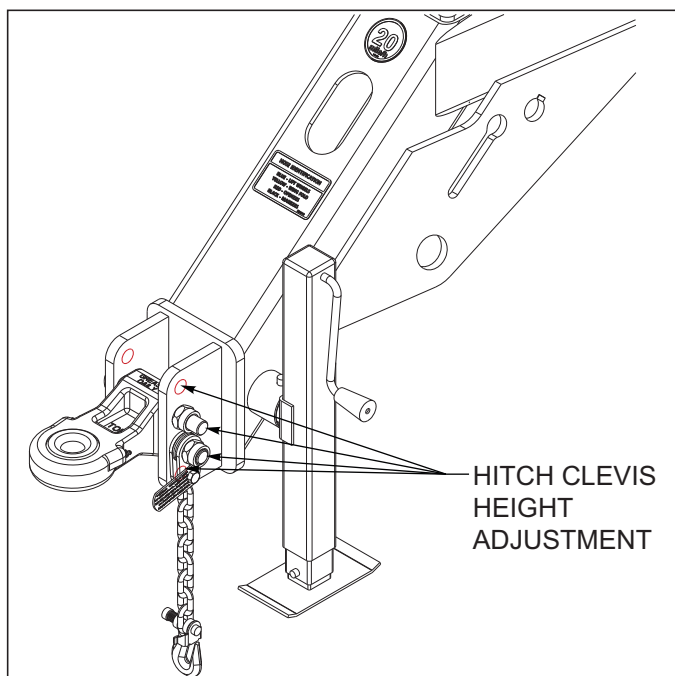

**Figure 4-3: Hitch Clevis Height**

## Transporting the Grain Drill

1. Check and follow all federal, state, and local requirements before transporting the Grain Drill.
2. The Grain Drill should be transported only by a tractor required for field operation. The implement weight should not exceed more than 1.5 times the tractor weight. Unless noted on the implement, maximum transport speed is 20 mph for the implement and is designated on the speed identification symbol (SIS) located on the front and rear of the implement *See Figure 4-4*.

**⚠ CAUTION**

**Excessive speed may result in loss of control of the tractor and implement, reduced braking, or failure of the implement tires or structure. Do not exceed the implement maximum specified ground speed regardless of the capability of the maximum tractor speed.**

3. When towing equipment in combination, the maximum equipment ground speed shall be the limited to the lowest specified ground speed of any of the towed implements.
4. Maximum transport speed shall be the lesser of travel speed specified in the operators manual, speed identification symbol, information sign of towed implement, or limit of road condition.

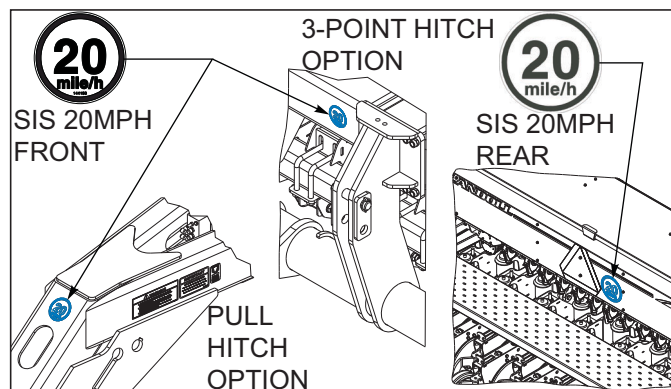

**Figure 4-4: SIS 20MPH Decal**

5. Slow down when driving on rough roads. Reduce speed when turning, or on curves and slopes to avoid tipping. Equipment altered other than the place of manufacture may reduce the maximum transport speed. Additional weight, added tanks, markers, harrow attachments, etc. may reduce the implements carrying capabilities.

6. A safety chain is provided with the implement to insure safe transport.

a. The safety chain should have a tensile strength equal to or greater than the gross weight of the implement. The chain is attached to the lower hitch clevis bolt with two flat washers between the clamp plates to assure a tight connection. Always use a 1" diameter Grade 8 bolt for this connection.

b. Attach the safety chain to the tractor drawbar *See Figure 4-5* Provide only enough slack in the chain for turning. Do not use an intermediate chain support as the attaching point for the chain on the tractor. Refer to the tractor operator's manual for proper safety chain attachment. Do not pull the implement by the safety chain.

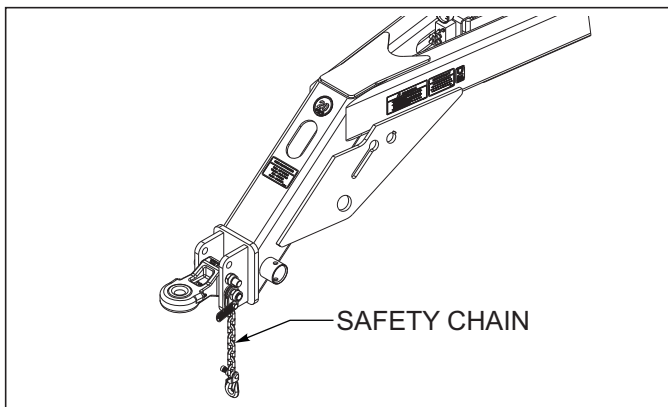

**Figure 4-5: Safety Chain**

c. When unhitching from the tractor attach the hook end of the chain to a free link close to the hitch clevis for storage. This will keep the hook off the ground, reducing corrosion, and keep the hook functioning properly.

d. Regularly inspect the safety chain for worn, stretched, or broken links and ends. Replace the safety chain if it is damaged or deformed in any way.

7. Before transporting:

a. Know the height and width of the implement being towed. Markers, tanks, attachments, etc. can increase the height and width of the implement.

### **DANGER**

**Stay away from power lines when transporting, extending or folding implement. Electrocutation can occur without direct contact.**

b. Check to see that the tractor drawbar is rated to carry the weight of the Grain Drill hitch.

c. Use a locking style hitch pin that properly fits the holes in the tractor drawbar and implement hitch.

d. Attach safety chain.

e. Plug in the safety lights to the tractor seven-pin connector.

f. Fully raise the Grain Drill markers and coulters.

g. Make sure all transport locks and pins are installed.

### **WARNING**

**Failure to use transport lock pins during transport may result in permanent equipment damage, serious injury, or death.**

h. Raise the implement parking jack stands and place in storage position.

i. Check all tires for proper inflation, and that lug nuts are properly torqued.

j. Verify that all warnings lights, SMV sign, reflectors, and safety decals are clearly visible and functioning properly.

k. Transport during daylight hours whenever possible. Always use flashing warning lights, except where such use is prohibited by law. Make sure lights, reflectors and SMV emblem are clearly visible and operating. Remove any obstructions such as dirt, mud, stalks or residue that restricts view before transporting.

l. Do NOT transport the drill with seed or fertilizer in the box.

### **CAUTION**

**Do not transport the Grain Drill with seed or fertilizer in the boxes. Seed, fertilizer, additional weight, markers, etc. can quickly exceed the carrying capabilities of the drill hitch and tractor drawbar.**

## Compressor Operation - Air Opener

1. The Grain Drill is equipped with a 12V DC air compressor to make minor adjustments in system air pressure. When making large adjustments in system pressure, use shop or alternate air source.
2. Power to the electric air compressor is supplied through the main lighting harness *See Figure 4-6*. Connect the seven pin connector to the tractor. It is recommended that the tractor be running while operating the compressor to insure full system voltage to the compressor. A toggle switch is located next to the compressor to turn the compressor on and off. A pressure switch will automatically turn off the air compressor off when maximum system pressure has been reached.
3. The air compressor is designed for oilless operation. There are no fluid levels to check or maintain. A replaceable air filter element is located at the front of the air compressor. Check and service the air filter element regularly to insure free flow of air and protect the compressor.

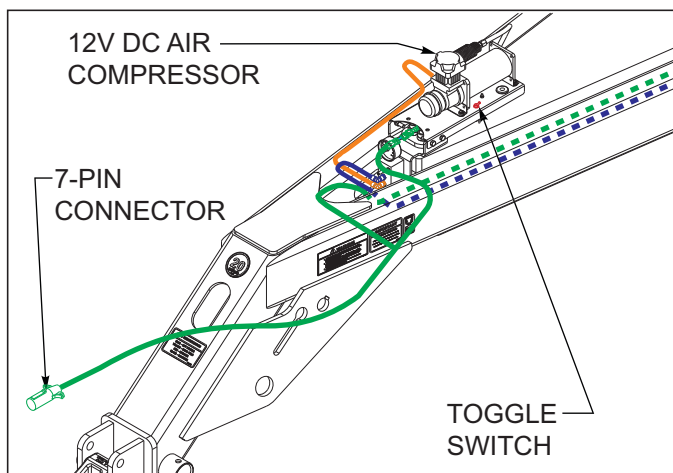

**Figure 4-6: Air Compressor Connection**

## Air System Pressure

1. The air system pressure on the Grain Drill can safely operate in a range from 15 psi to 100 psi. A system pressure gauge is located at the front of the hitch *See Figure 4-7* and is used to monitor system pressure. It is normal for the system air pressure to vary while working in the field. As the openers raise and lower over ground conditions, so will the system pressure vary.
2. Do not at any time operate the air system below 15 psi. The air springs must maintain a minimum air pressure for proper inflation. Too low of pressure will cause the air spring to rub internally and lead to failure.

3. System pressure should not exceed 100 psi. This is the maximum recommended working pressure the air springs are rated for. This will provide maximum down pressure for the row units. A system relief valve is installed at the front of the hitch to protect the system from excessive pressure. Do not remove or adjust the relief valve or damage to the air system may occur.
4. To adjust the air system pressure, use the on board HD air compressor to increase system pressure. Turn the switch on to the compressor until the desired pressure setting is reached, then turn off the compressor. To lower or drain system pressure, pull and hold the ring located at the bottom of the relief valve on the front of the hitch.
5. Initial settings – When beginning planting operations, use a system pressure of 20-50 psi for light or sandy soils, 40-60 psi for medium or conventional tilled soils, and 70-100 psi for heavy and no-till planting. These are initial settings. Operator must verify seed placement and adjust air system pressure as required.

### **NOTE**

***Excessive air pressure can raise the drive wheels and openers off the ground.***

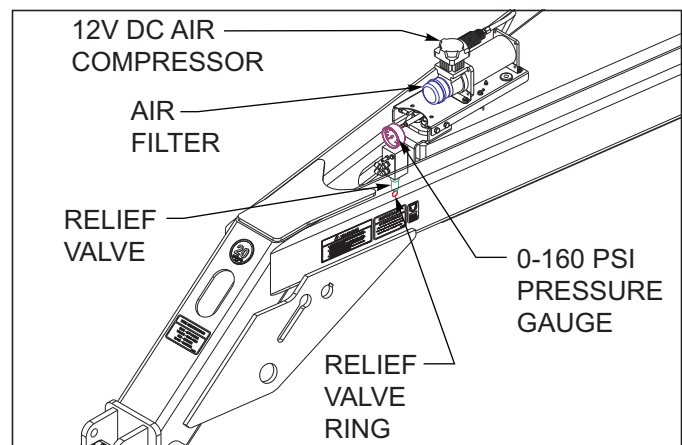

**Figure 4-7: Air System Pressure**

6. Maintenance – Relieve air system pressure before attempting to adjust or service any air spring. Do not pressurize the air system unless all row unit components are in place. Repair any system air leaks to avoid excessive compressor use. Use a spray bottle with soap and water solution to check for leaks. When charging the system, verify that all air springs are filling properly. If the air spring buckles or rolls off to the side, relieve system pressure, and work or roll the air spring over the lower piston by hand. Slowly begin charging the system and verify proper filling.
7. Storage – Store the drill inside when not in use. Leave the air system charged. It is not necessary to bleed the system for storage.

### Hydraulic Lift System - Pull Hitch

The Grain Drill is equipped with a hydraulic lift system to raise and lower the unit from transport to planting position.



#### WARNING

Escaping hydraulic fluid can cause serious personnel injury. Relieve system pressure before repairing, adjusting, or disconnecting. Wear proper hand and eye protection when searching for leaks. Use cardboard instead of hands *See Figure 4-8*. Keep all components (cylinders, hoses, fittings, etc.) in good repair.

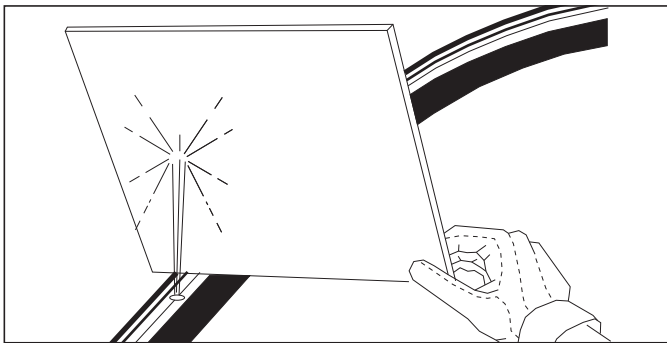

**Figure 4-8: Hydraulic Leak Detection**

1. The hydraulic lift system contains cylinders plumbed together.
2. Before transporting make sure lift cylinders are fully extended for maximum transport height.
3. The Grain Drill can have both positive and negative hitch weight. Attach the drill to the tractor before attempting to raise or lower the drill hydraulically.
4. Field Operation
  - a. Before starting field operation, fully raise the drill and remove cylinder lockouts *See "Storage & Transport Position of Lockouts" on page 4-5*. Un-pin parking stands and rotate into storage position.
  - b. Lower the drill completely when planting to insure consistent depth.
  - c. Raise the drill when making sharp turns to prevent side load/damage to the openers.
  - d. Never back up the Grain Drill with the openers in the ground. This can plug and possibly damage the openers. Always fully raise the drill before backing.
  - e. Fully raise the drill and install the cylinder lockouts before transporting or working beneath the drill *See "Storage & Transport Position of Lockouts" on page 4-5*.

## **Seed Meter Gate Adjustment**

The seed meter has an adjustable seed gate to accommodate various seed sizes for planting. The seed gate is adjusted by the handle on the outside of each seed meter.

1. Use the top seed gate position when planting small seeds such as alfalfa, barley, grass, oats, rice, or wheat **See Figure 4-9.**

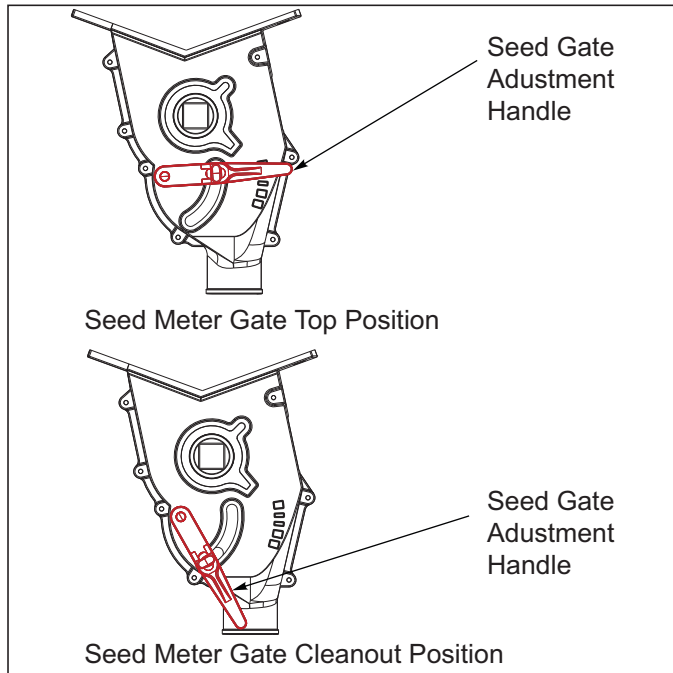

**Figure 4-9: Seed Meter Gate Adjustment**

2. The second seed gate position is for peas, small soybeans, etc. If excess cracking occurs, move the handle to the third position.
3. Use the third seed gate position for large peas, large soybeans, etc.
4. A fourth notch is for extremely large seeds such as garbanzo beans.

### **NOTE**

*Before filling the drill and planting, make sure all seed gate settings are the same for all meters.*

5. The seed gate may also be completely lowered to clean out the meter and seed box **See Figure 4-9.** Fully open all seed meter gates at the end of planting season to clean out any remaining seed.

### **NOTE**

*Do not attempt to fully open the seed meter gate unless you are ready to empty the seed box. Once the gate is open, it may be difficult to close the seed meter gate until the seed box is empty.*

## Seed Rate Adjustment

1. Wrenches are provided to adjust the seed rate. They are stored on outside end of LH seed box *See Figure 4-10.*

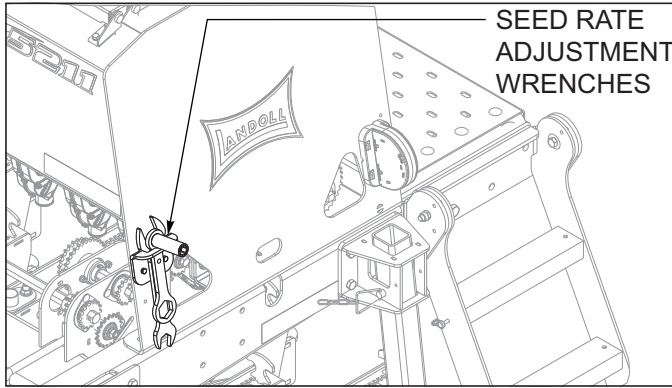

**Figure 4-10: Wrench Storage Position**

2. The seeding rate is adjusted for each section with the threaded seed rate adjustment at one end of each drill section. The end seed meter next to the adjustment has an indicating scale for reference. Read the scale along the outside edge of the seed meter to determine the setting. The seeding rate should be set the same for all sections *See Figure 4-12.*

a. To set the seeding rate, first determine from the seed rate chart the meter opening for the desired seed rate. The seed rate chart is located inside the lid of the center seed box *See Figure 4-13.*

b. Loosen the locking nut on the square seed shaft with the adjustment wrench *See Figure 4-11.*

c. Using the seed rate adjustment wrench, insert the socket through the hole in the end box support to the hex-head adjustment bushing. Turn the hex-head adjustment bushing in or out, until the desired rate setting is obtained along the **OUTSIDE EDGE** of the seed meter.

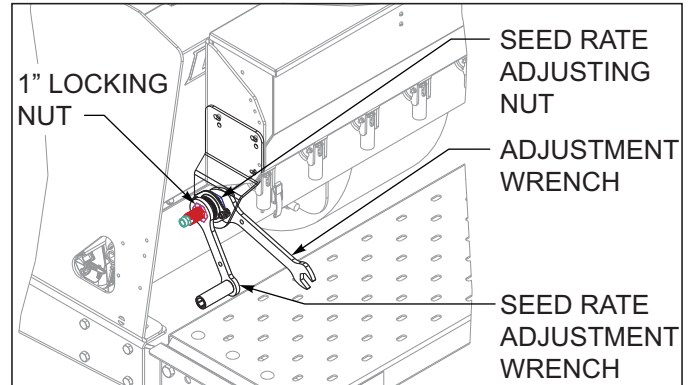
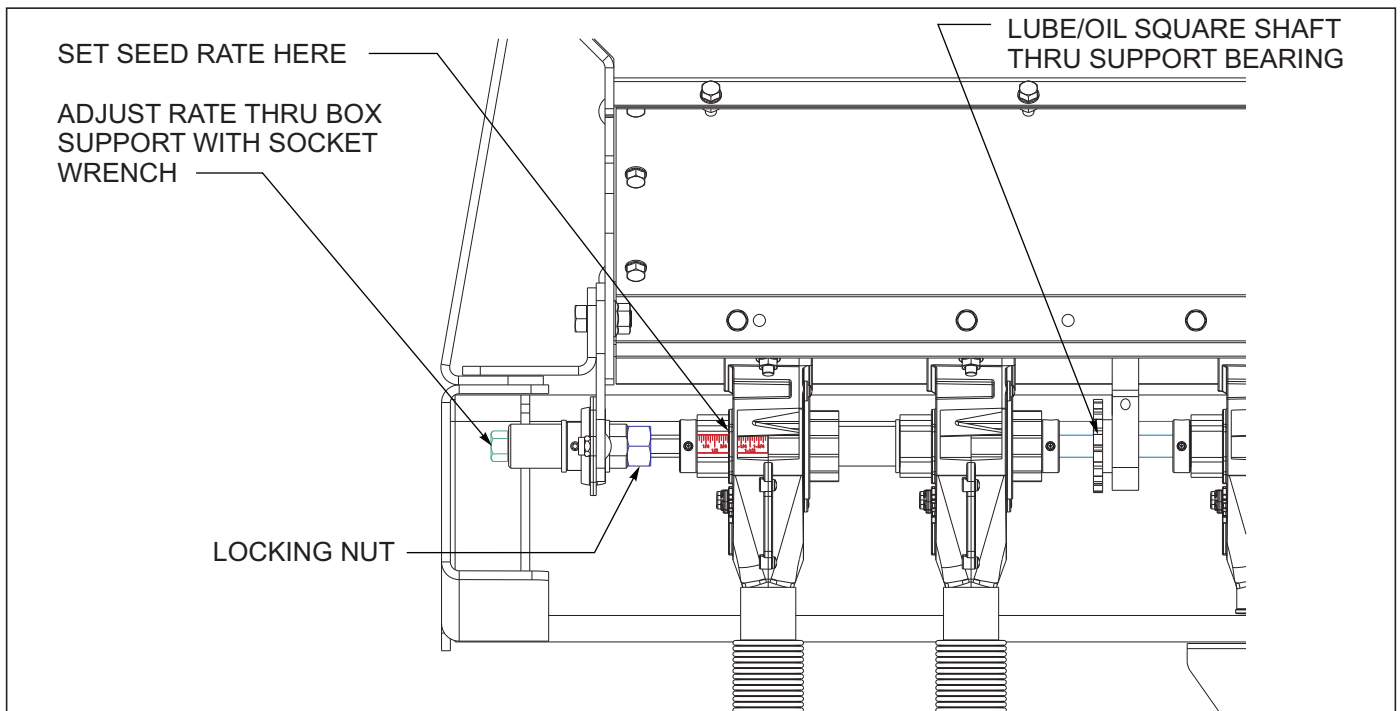

**Figure 4-11: Wrench Adjustment Position**

d. Re-tighten the locking nut against end bushing to secure the seed rate setting, not seed meter.

**NOTE**

*Do not force the seed meter shaft, damage will occur. The meter will not be able to fully close if there is seed in the box. Lube/oil the square seed shaft so that it will easily slide through the support bearing while adjusting.*



**Figure 4-12: Seed Rate Adjustment**

## Meter/Seed Rate Handle Adjustment

1. If the seed meter shaft is disassembled for maintenance or repair the seed meters and adjustment will need to be reset or zeroed to set the meters equally across the section.
2. Remove any remaining seed from the seed box.
3. To reset the meters, loosely reassemble the shaft, meters, spacers, locking collars etc. but leave the locking collars loose.
4. Tighten the threaded seed shaft adjustment to hold in place.
5. Start with the end meter(s) next to the threaded adjustment *See Figure 4-12*. Slide the feed roll and cut-off to the right until the indicator reads zero on the end meter. Remove any remaining slack between the spacers, washers, feed rolls etc. and secure the lock collars on each end of that group of meters. Continue to work across the drill section sliding the meter feed rolls to the right, removing any slack, and securing the lock collars for each group of meters.

6. With all lock collars secure on the seed shaft and all slack removed from between the spacers, verify that each meter is actually zeroed out. The feed roll should not be protruding or recessed inside any of the meters. To fine tune each meter, if necessary, loosen the two bolts holding the meter housing to the bottom of the seed box. Slide the meter housing to the right or left, until the meter is zeroed out. Re-tighten the meter housing to the bottom of the seed box.
7. Set the seed rate adjustment to the desired rate *See Figure 4-14*.

**NOTE**

*Do not force the seed meter shaft, damage will occur.*

$$\text{SEED RATE} = \frac{(\text{AVG SEED WEIGHT}) \times 65896}{(\text{NO. OF ROTATIONS}) \times (\text{ROW SPACING})}$$

$$\text{EXAMPLE} = \frac{(.1707 \text{ LBS.}) \times 65896}{(20 \text{ ROTATIONS}) \times (7.5'')} = \mathbf{75 \text{ LBS./ACRE}}$$

$$\# \text{ SEEDS per ROW} = \frac{(\text{SEED RATE}) \times (\text{SEEDS/LB}) \times (\text{NO. OF ROTATIONS}) \times (\text{ROW SPACING})}{65896}$$

$$\text{EXAMPLE} = \frac{(60 \text{ LBS./ACRE}) \times (2,500 \text{ SEEDS/LB}) \times (20 \text{ ROTATIONS}) \times (7.5'')}{65896} = \mathbf{341 \text{ SEEDS PER ROW}}$$

$$\# \text{ SEEDS per ROW} = \frac{(\text{POPULATION}) \times (\text{NO. OF ROTATIONS}) \times (\text{ROW SPACING})}{65896}$$

$$\text{EXAMPLE} = \frac{(50,000 \text{ POPULATION}) \times (20 \text{ ROTATIONS}) \times (7.5'')}{65896} = \mathbf{114 \text{ SEEDS PER ROW}}$$

**Figure 4-13: Seed Rate Calibration Formulas**

# TABLE OF CONTENTS



## SEEDING RATE CHART

Seeding rates are in pounds per acre, based on average seed size.  
Rates are approximate, operator must verify actual seeding output.

SEED	ALFALFA				BARLEY				FESCUE				MILLET				MILO				OATS				RICE				SOYBEAN				WHEAT				SEED							
	7-1/2		10		7-1/2		10		7-1/2		10		7-1/2		10		7-1/2		10		7-1/2		10		7-1/2		10		7-1/2		10													
	DRIVE	I	II	I	II	I	II	I	II	I	II	I	II	I	II	I	II	I	II	I	II	I	II	I	II	I	II	I	II	DRIVE														
METER OPENING (INCHES)	1/8	8	4	6	3					4	2	3	1	8	4	6	3	9	4	6	3									10	5	7	4	1/8										
	1/4	16	8	12	6	14	7	10	5	8	4	6	3	15	7	11	6	16	8	12	6								19	9	14	7	1/4											
	3/8	24	12	18	9	21	10	15	8	11	6	9	5	23	11	17	9	26	13	19	10							17	9	13	7	26	13	19	7	29	14	21	11	3/8				
	1/2	32	16	24	12	28	14	21	10	16	8	12	6	31	15	23	11	37	18	28	14							23	12	18	9	38	19	28	14	38	19	29	14	1/2				
	5/8	40	20	30	15	36	18	27	13	19	9	14	7	39	20	29	15	48	24	36	18							30	15	23	11	53	26	40	20	50	25	37	19	5/8				
	3/4	49	25	36	19	44	22	33	16	23	12	18	9	48	24	36	18											30	15	23	11	37	19	29	14	66	33	50	25	61	31	46	23	3/4
	7/8	58	29	43	22	52	26	39	20	28	14	21	11	58	29	43	22											36	18	27	13	44	22	33	17	82	41	61	31	73	36	54	27	7/8
	1	66	33	49	25	60	30	45	23	31	16	23	12	67	33	50	25											41	20	31	16	51	26	38	19	94	47	70	35	84	42	63	32	1
	1-1/8					70	35	52	26	36	18	27	14															48	24	36	18	59	30	44	22	##	56	84	42	97	49	73	36	1-1/8
	1-1/4					79	39	59	30	40	20	30	15															54	27	40	20	67	33	50	25	##	65	98	49	##	55	83	41	1-1/4
	1-3/8					89	44	67	33	44	22	33	17															61	30	46	23	75	38	56	28	##	76	##	57	##	62	93	46	1-3/8
	1-1/2					##	50	75	38	47	24	35	18															69	34	51	26	85	42	64	32	##	81	##	61	##	70	##	52	1-1/2
	1-5/8					##	56	84	42	52	26	39	20															77	39	58	29	95	48	71	36	##	91	##	68	##	78	##	59	1-5/8
	1-3/4					##	61	91	46	55	28	41	21															84	41	62	31	##	52	77	39	##	95	##	70	##	85	##	64	1-3/4

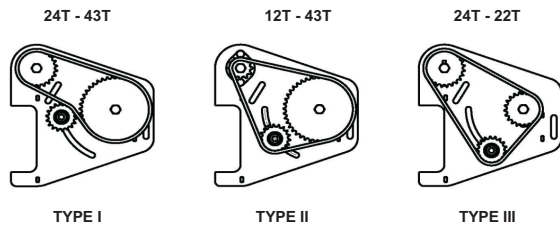

Note:  
Drive type I is standard speed  
Drive type II is half speed  
Drive type III is double speed

176490

176490 Seed Rate Chart (7-1/2" & 10" Spacing)



## SEEDING RATE - 6" ROW SPACING

Seeding rates are in pounds per acre, based on average seed size.  
Rates are approximate, operator must verify actual seeding output.

SEED	ALFALFA			BARLEY			FESCUE			MILLET			MILO			OATS			RICE			SOYBEAN			WHEAT			SEED					
	6			6			6			6			6			6			6			6											
	DRIVE	I	II	III	I	II	III	I	II	III	I	II	III	I	II	III	I	II	III	I	II	III	I	II	III	DRIVE							
METER OPENING (INCHES)	1/8	10	5	20			5	3	10	10	5	20	11	6	22											13	7	26	1/8				
	1/4	20	10	40	18	9	36	9	5	18	19	10	38	20	10	40										24	12	48	1/4				
	3/8	30	15	60	26	13	52	14	7	28	29	15	58	33	17	66				21	11	42	33	17	66	36	18	72	3/8				
	1/2	40	20	80	35	18	70	20	10	40	39	20	78	46	23	92				29	15	58	48	24	96	48	24	96	1/2				
	5/8	50	25	100	45	23	90	24	12	48	49	25	98	60	30	120				38	19	76	66	33	132	63	32	126	5/8				
	3/4	61	31	122	55	28	110	29	15	58	60	30	120							46	23	92	83	42	166	76	38	152	3/4				
	7/8	73	37	146	65	33	130	35	18	70	73	37	146							51	26	102	64	32	128	118	59	236	105	53	210	7/8	
	1	83	42	166	75	38	150	39	20	78	84	42	168							60	30	120	74	37	148	140	70	280	121	61	242	1	
	1-1/8				88	44	176	45	23	90										68	34	136	84	42	168	164	82	328	138	69	276	1-1/8	
	1-1/4				99	50	198	50	25	100										76	38	152	94	47	188	190	95	380	155	78	310	1-1/4	
	1-3/8				111	56	222	55	28	110										86	43	172	106	53	212	203	102	406	175	88	350	1-3/8	
	1-1/2				125	63	250	59	30	118										96	48	192	119	60	238	226	113	452	196	98	392	1-1/2	
	1-5/8				141	71	282	65	33	130										105	53	210	129	65	258	231	116	462	213	107	426	1-5/8	
	1-3/4				153	77	306	69	35	138																							1-3/4

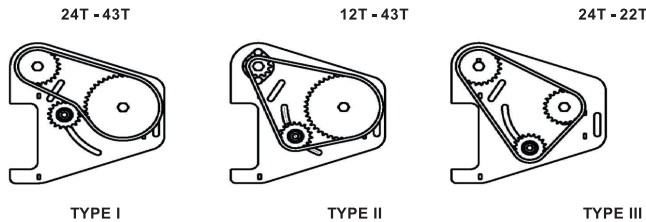

Note:  
Drive type I is standard speed  
Drive type II is half speed  
Drive type III is double speed

235328

235328 Seed Rate Chart (6" Spacing)

Figure 4-14: Seed Rate Chart

## Seed Rate Calibration

1. The seed rate charts are in pounds per acre and based on an average seed size *See Figure 4-14*. Several factors can influence seeding rates: seed varieties, seed size, seed weight, seed treatment, seed cleanliness, tire pressure, tire slippage, and tire size.

### **NOTE**

***The operator must verify actual seed output before planting to insure the desired seeding rate.***

2. If the specific seed is not listed on the seed chart, pick a similar seed size and check the seed calibration for the desired rate.
3. To check the seeding rate:
  - a. Adjust the seeding rate and drive type to the desired rate from the seed chart *See Figure 4-14*.
  - b. Select three seed meters next to each other, and disconnect the rubber seed tubes to be able to catch the seed.
  - c. Fill the seed box with a sufficient amount of seed over the three meters.
  - d. Rotate the drive wheel several times, until the 3 meters begin to deliver seed evenly.
  - e. With an empty container collect the seed from the three seed meters as you rotate the drive wheel by hand. Count the total number of rotations. Twenty rotations would be a good starting point; more rotations will produce more accurate results.
  - f. Weigh (in pounds) the total amount of seed and divide by 3 for an average amount of seed per meter. *See Figure 4-13* for seed rate formula.
4. Adjust the seed meter rate to compensate for any variation, and repeat the seed calibration until the desired seeding rate is achieved.
5. *See Figure 4-13* for number of seeds per row formula.

## Dry Fertilizer Combination Box

1. If the Grain Drill is equipped with the dry fertilizer option, it will have a combination seed/fertilizer box. The seed/fertilizer box is split for approximately 60% (2 bu/ft) seed and 40% (1.25 bu/ft) fertilizer. The box may be used for applying both seed and fertilizer, or converted to use both compartments entirely for seed.
  - a. To use the dry fertilizer option, the covers in the bottom of the rear fertilizer compartment must have the openings to the rear *See Figure 4-15*. This will close off openings to the seed compartment and allow dry fertilizer to enter the fertilizer meters.
  - b. For increased seed capacity and non fertilizer use, the covers should be reversed with the openings to the front of the seed box, and the solid portion covering the fertilizer meters *See Figure 4-16*.
2. To change the fertilizer covers, remove the plastic knobs holding each of the covers in place at the bottom of the rear fertilizer compartment. Lift the cover out, and reposition the cover with the openings to the front or rear as desired. Insure the cover is slid down to the bottom and reinstall the plastic knobs to retain the covers.

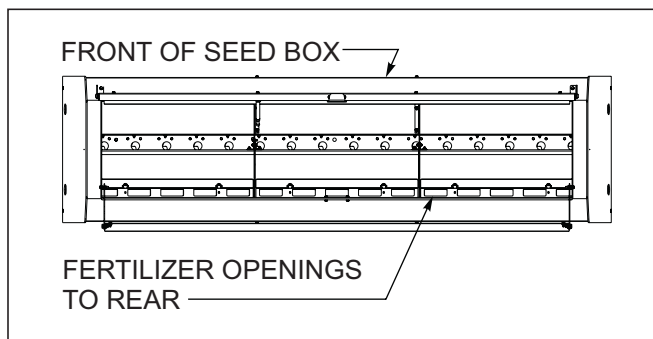

**Figure 4-15: Fertilizer Box w/Cover Opening to Rear**

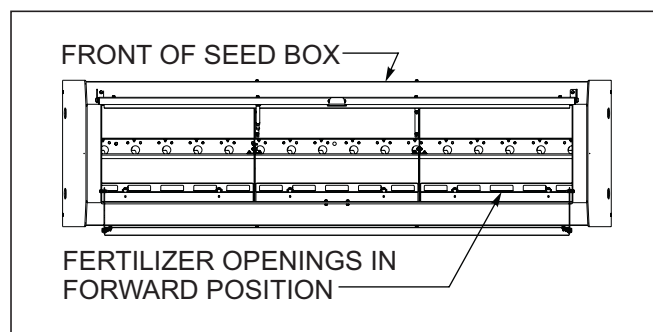

**Figure 4-16: Fertilizer Box w/Cover Opening Forward**

## TABLE OF CONTENTS

3. When using both seed and dry fertilizer, fill the seed box keeping fill shield in closed position over fertilizer box **See Figure 4-17.**

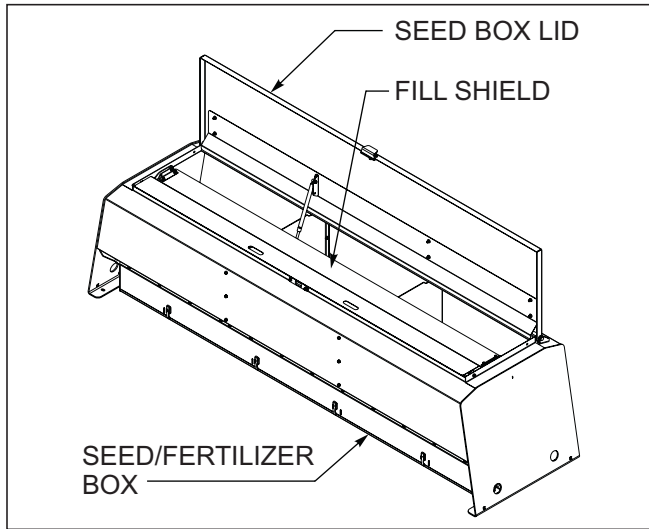

**Figure 4-17: Fill Shield in the Closed Position**

4. When using both seed and dry fertilizer, open fill shield up shielding the seed box and fill with dry fertilizer **See Figure 4-18.**

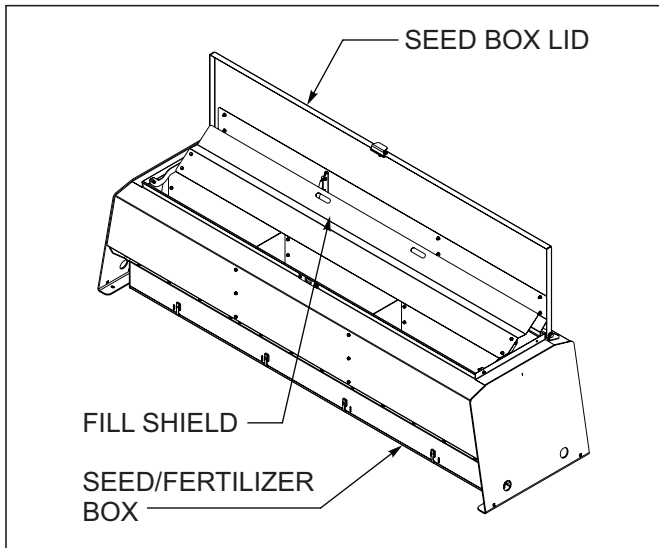

**Figure 4-18: Fill Shield in Raised Position**

5. When both compartments are being used for seed, open seed box lids and lift and rotate the fill shield over the rear of the seed box. This allows the compartments to be filled at the same time. This also improves access for maintenance and cleaning **See Figure 4-19.**

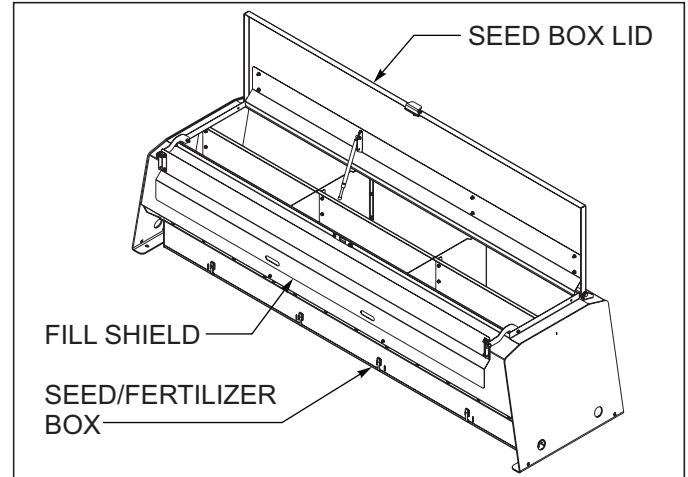

**Figure 4-19: Both Compartments Filled w/ Seed**

## **Fertilizer Box – Clean Out**

1. The fertilizer meters may be accessed for maintenance or cleaning by removing the door located at the bottom of the fertilizer meter assembly **See Figure 4-20.**
2. Remove any remaining dry fertilizer from inside the fertilizer compartment. Be prepared to catch the remaining fertilizer before opening the door. Position the drill over a smooth, clean, dry surface, or spread out a tarp below the box. Release and unhook the

latches and allow the door to swing forward.

3. Dry fertilizer is very corrosive and absorbs moisture. Clean out any fertilizer as soon as possible after using the drill.
4. Storage – before storing the drill for extended periods, clean out any remaining seed and fertilizer from the boxes. Remove the fertilizer doors on the outside of the box and fertilizer covers on the inside of the box. Use water to wash out any remaining fertilizer within the boxes and in the fertilizer meter assemblies.

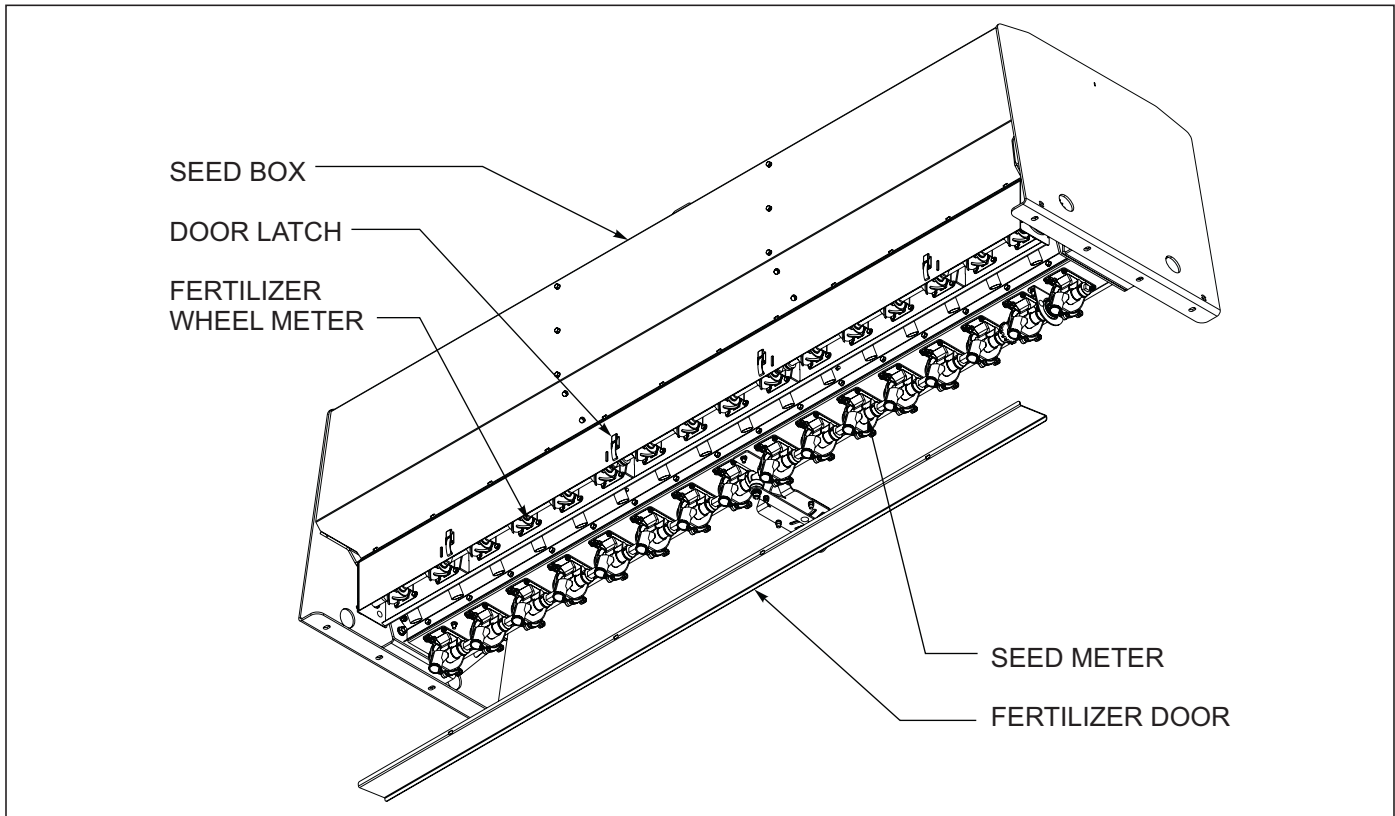

**Figure 4-20: Fertilizer Box Clean Out**

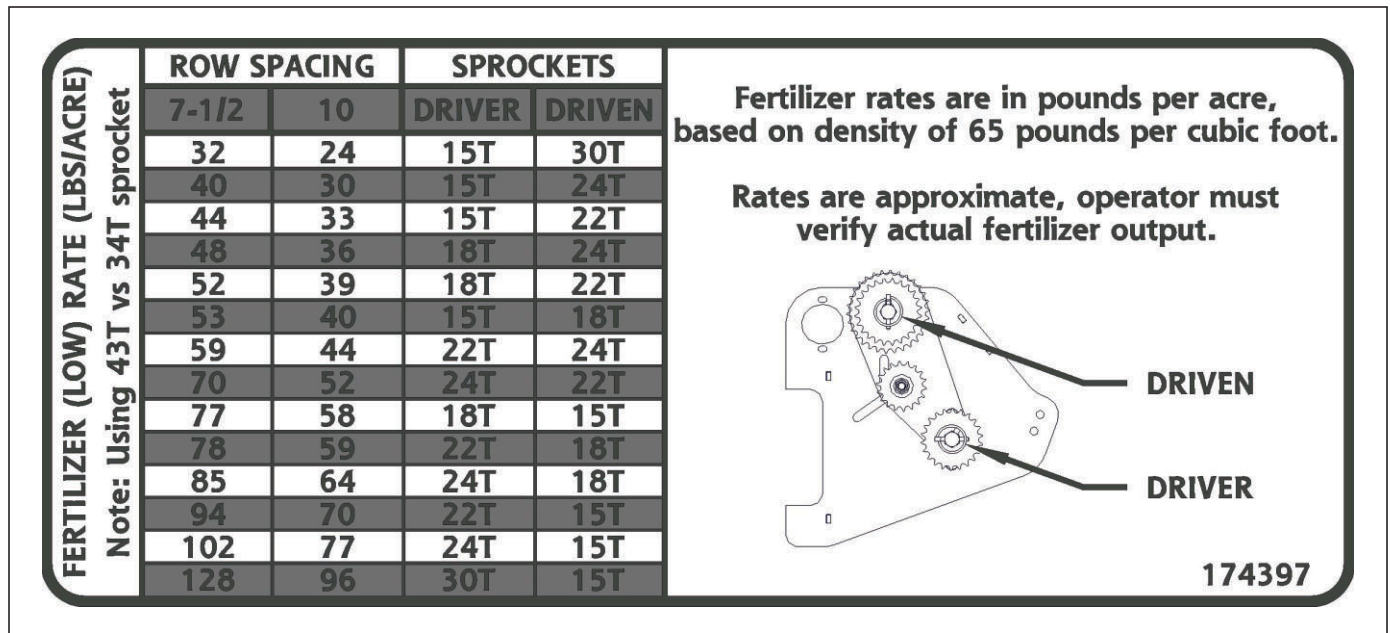

Figure 4-21: Fertilizer Box Chart

## Fertilizer – Rate Adjustment

1. The dry fertilizer rate is adjusted by changing sprocket ratios for each section. *See Figure 4-21* for desired settings. For best results use clean dry fertilizer, free of clumps, or foreign material.

2. The fertilizer chart is based upon average size dry fertilizer with a density of 65 lbs per cubic foot. If using a fertilizer with a different density, apply the following conversion factors, and use the closest rate for application *See Table 4-1*.

### **IMPORTANT**

The operator must verify actual fertilizer output before planting.

Dry Fertilizer Density Conversion Chart Based on Average Density of 65 lbs./ft.							
Density	50	55	60	65	70	75	80
Conversion Factor	1.30	1.18	1.08	1.00	.93	.87	.75

Example: using a dry fertilizer with a density of 70 lbs/ft<sup>3</sup> and a desired application rate of 50 lbs/acre.

$50 \times .93 = 46.5$  (use a setting from the rate chart nearest 46.5 lbs/acre)

Table 4-1: Dry Fertilizer Density Conversion Chart

## Fertilizer – Rate Calibration

1. Dry fertilizer can be affected by type, density, size, humidity, and field conditions. Operator should verify actual fertilizer rate output before planting.
2. To check the fertilizer rate:
  - a. With a desired fertilizer rate and known density apply the above conversion factor and select rate from chart. If density is not known, use desired rate based on 65 lbs/ft<sup>3</sup> from the chart.
  - b. Adjust the sprocket ratio to the desired rate.
  - c. Select three fertilizer meters next to each other and disconnect the rubber tubes from these meters to be able to collect fertilizer.
  - d. Fill the fertilizer box with a sufficient amount of fertilizer over the top of the three meters.
  - e. Lower the openers so the drive wheel clutch will engage.
  - f. Place a jack under the appropriate drive wheel and raise off the ground so the drive wheel may be rotated by hand.
  - g. Rotate the drive wheel several times, until the three meters begin to deliver fertilizer evenly.
  - h. With an empty container begin collecting the fertilizer from the three meters as you rotate the drive wheel by hand. Count the total number of rotations. Twenty rotations would be a good starting point; more rotations will produce more accurate results.
  - i. Weigh (in pounds) the total amount of fertilizer (less the container) and divide by 3 for an average amount of fertilizer per meter.

$$\text{FERTILIZER RATE} = \frac{(\text{AVG FERTILIZER WT}) \times 65896}{(\text{NO. OF ROTATIONS}) \times (\text{ROW SPACING})}$$

$$\text{EXAMPLE} = \frac{(.1138 \text{ LBS.}) \times 65896}{(20 \text{ ROTATIONS}) \times (7.5" \text{ SPACING})} = 50 \text{ LBS./ACRE}$$

3. Compare the actual fertilizer rate with the starting rate and compensate for any variation. Repeat the calibration until the desired fertilizer rate is achieved. Adjust the sprocket ratios on the other sections to match the calibrated setting.
4. Continue to monitor the fertilizer rate while planting. Note the amount of acres planted versus the amount of fertilizer added to the drill. If you are applying more or less fertilizer than desired, adjust the metering rate to compensate for field conditions and fertilizer.

## Small Seed Rate Adjustment



### WARNING

- To prevent damage to the seed meters, do not apply excessive force to the adjusting nuts. Failure to do so may result in the seed being pinched between the cut-off and washer inside the seed cup.
- Do not close the meters more than 1/8" when there is seed in the meters without rotating the seed shaft. This prevents damage to the rotating washers and retainer rings in the seed meters.
- Do not attempt to open meters more than 1". (Feed rolls could become disengaged from washer in the seed cup.)

### NOTE

*To avoid seed meter damage, if there is seed in the meters, decrease rate in small increments. Decrease rate no more than one nut revolution and rotate seed shaft to purge seed from meters. Continue adjustments as needed.*

### NOTE

*Before filling with seed be sure seed shaft turns freely and seed meters are free from any foreign matter.*

1. The seeding rate adjustment for the optional small seeding attachment is located at the outer rear of each seeding box. The seeding rate should be set the same for all seeding boxes. On 15' and 20' drills there will be two adjustments.
2. The small seeding rate is set independent of the seeding rate and drive type on the main seeding hopper.
3. Adjustments to the small seeding attachment will be easier if the boxes are empty of seed before adjusting. The meters will not be able to be fully closed if there is seed in the hopper. Do not force the adjustment or damage may occur to the meters.
4. To set the seeding rate:
  - a. First determine from the seeding rate chart inside seed box cover, the meter opening for the desired seed rate **See Figure 4-24 to See Figure 4-26**. It should be used as a general guide only.
  - b. Rotate the small seed shaft until the letters and numbers on the adjustment are clearly visible **See Figure 4-23**.
  - c. Wrenches are provided to adjust the seed rate. They are stored on outside end of LH seed box **See Figure 4-10**.

## TABLE OF CONTENTS

d. Loosen the 1" locking nut with the seed rate adjusting wrench **See Figure 4-22** and **See Figure 4-23**.

e. Turn the large seed rate adjusting nut with the adjustment wrench of the seed shaft bearing in or out to the desired setting **See Figure 4-22** and **See Figure 4-23**. The desired letter on the seed rate adjusting nut should be aligned with the number scale. The face of the nut should align to the desired number setting.

f. Re-tighten the 1" locking nut with the seed rate adjusting wrench against the bearing.

### NOTE

Seeding rates are based on clean untreated average size seed. Actual rates may vary, operator must verify actual seed output. If a specific seed is not listed, use a seeding rate for a similar sized seed, and verify output before planting.

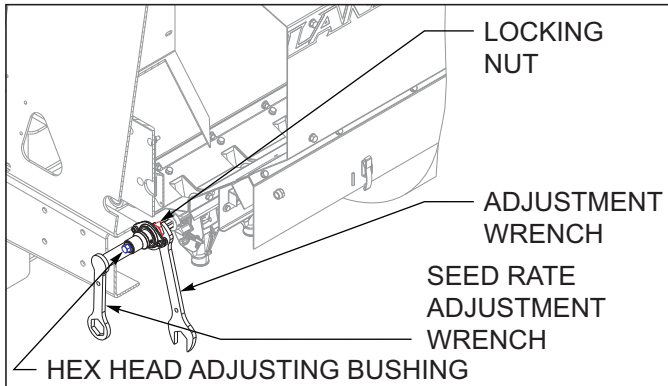

**Figure 4-22: Wrench Adjustment Position**

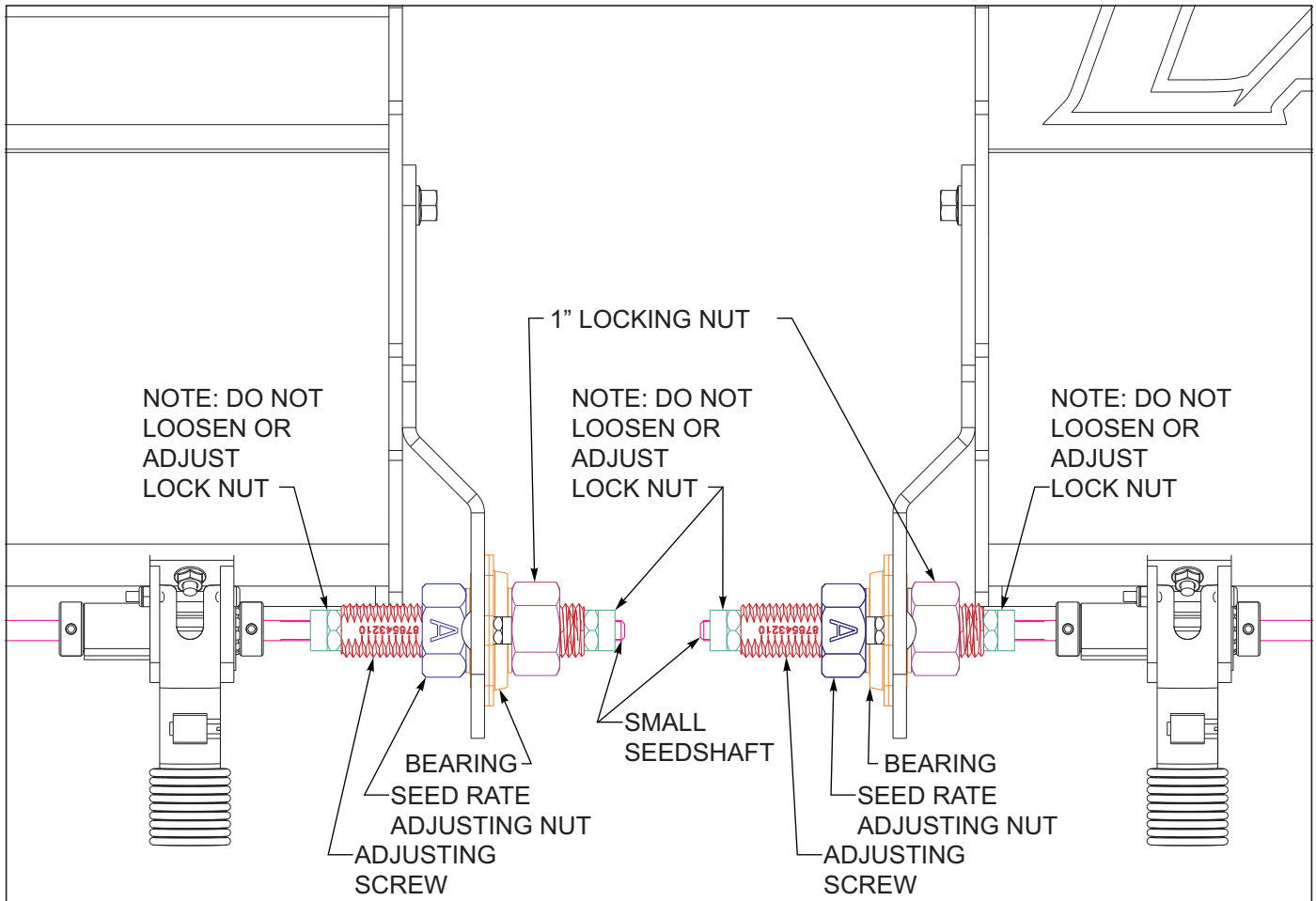

**Figure 4-23: Small Seed Rate Adjustment**

### Seed Rate Calibration

1. The seed rate charts are in pounds per acre and based on an average seed size 6" spacing [See Figure 4-24](#) for 7-1/2" spacing [See Figure 4-25](#) for 10" spacing [See Figure 4-26](#). For rate calibration formula [See Figure 4-13](#). Several factors can influence seeding rates: seed varieties, seed size, seed weight, seed treatment, seed cleanliness, tire pressure, tire slippage, and tire size.

#### **NOTE**

***The operator must verify actual seed output before planting to insure the desired seeding rate.***

2. If the specific seed is not listed on the seed chart, pick a similar seed size and check the seed calibration for the desired rate.
3. To check the seeding rate:
  - a. Select three seed meters next to each other, and disconnect the rubber seed tubes to be able to catch the seed.

- b. Fill the box with a sufficient amount of seed over the three meters.

- c. Lower the openers to planting position to engage the seed clutch.

- d. Place a jack under the appropriate drive wheel and raise off the ground so the drive wheel may be rotated by hand.

- e. Collect the seed from the three seed meters as you rotate the drive wheel by hand. Count the total number of rotations. Twenty rotations would be a good starting point; more rotations will produce more accurate results.

- f. Weigh (in pounds) the total amount of seed and divide by 3 for an average amount of seed per meter. 6" spacing [See Figure 4-24](#) for 7-1/2" spacing [See Figure 4-25](#) for 10" spacing [See Figure 4-26](#). For rate calibration formula [See Figure 4-13](#).

4. Adjust the seed meter rate to compensate for any variation, and repeat the seed calibration until the desired seeding rate is achieved.

# TABLE OF CONTENTS

SEED		ROW SPACING	INDICATOR SETTING								SEED		ROW SPACING	INDICATOR SETTING							
			1A	2A	3A	4A	5A	6A	7A	8A				1A	2A	3A	4A	5A	6A	7A	8A
ALFALFA (Uncoated)		6	3	7	12	18	21	27	32	36	LESPEDEZA (Hulled)		6	3	7	12	18	21	28	34	37
ANNUAL RYE GRASS		6	1	4	6	10	13	18	20	23	LESPEDEZA (Unhulled)		6	1	6	9	13	19	22	28	32
BIRDSFOOT TREFOIL		6	3	8	13	19	28	34	41	47	LOVE GRASS (Sand)		6	3	7	10	15	20	25	31	36
BLUEGRASS (Kentucky)		6	1	3	4	7	8	10	12	13	LOVE GRASS (Weeping)		6	1	8	13	18	22	29	34	41
BLUEGRASS (Park Kentucky)		6	1	4	7	10	13	18	20	22	MILLET		6	3	8	13	19	22	29	34	41
CANOLA		6	1	7	10	16	20	24	28	34	ORCHARD GRASS		6	-	1	3	4	5	6	8	9
CLOVER (Crimson)		6	3	6	10	16	22	26	34	40	RED TOP		6	1	3	6	7	8	9	10	12
CLOVER (Ladino, Sweet, Red)		6	3	11	16	22	29	35	41	48	REED CANARY GRASS		6	1	3	6	8	9	12	13	16
KLEIN GRASS		6	3	7	13	18	24	31	37	41	TIMOTHY		6	3	6	9	15	19	24	29	34

**Figure 4-24: 6" Small Seed Rate Chart**

SEED		ROW SPACING	INDICATOR SETTING								SEED		ROW SPACING	INDICATOR SETTING							
			1A	2A	3A	4A	5A	6A	7A	8A				1A	2A	3A	4A	5A	6A	7A	8A
ALFALFA (Uncoated)		7-1/2	2	5	10	14	17	22	25	29	LESPEDEZA (Hulled)		7-1/2	2	5	10	14	17	22	27	30
ANNUAL RYE GRASS		7-1/2	1	3	5	8	10	14	16	18	LESPEDEZA (Unhulled)		7-1/2	1	4	7	10	15	18	22	25
BIRDSFOOT TREFOIL		7-1/2	2	7	10	15	22	27	33	38	LOVE GRASS (Sand)		7-1/2	2	5	8	12	16	20	25	29
BLUEGRASS (Kentucky)		7-1/2	1	2	3	5	7	8	10	11	LOVE GRASS (Weeping)		7-1/2	1	7	10	14	18	23	28	33
BLUEGRASS (Park Kentucky)		7-1/2	1	3	5	8	10	14	16	18	MILLET		7-1/2	2	7	10	15	19	23	28	33
CANOLA		7-1/2	1	5	8	13	16	19	22	27	ORCHARD GRASS		7-1/2	-	1	2	3	4	5	6	7
CLOVER (Crimson)		7-1/2	2	5	8	13	18	21	25	32	RED TOP		7-1/2	1	2	4	5	7	8	9	10
CLOVER (Ladino, Sweet, Red)		7-1/2	2	7	10	14	18	22	25	30	REED CANARY GRASS		7-1/2	1	2	4	6	8	10	12	14
KLEIN GRASS		7-1/2	2	5	10	14	19	25	30	33	TIMOTHY		7-1/2	2	4	7	12	15	19	23	27

**Figure 4-25: 7-1/2" Grass Seed Rate Chart**

SEED		ROW SPACING	INDICATOR SETTING								SEED		ROW SPACING	INDICATOR SETTING							
			1A	2A	3A	4A	5A	6A	7A	8A				1A	2A	3A	4A	5A	6A	7A	8A
ALFALFA (Uncoated)		10	2	4	8	11	13	17	19	22	LESPEDEZA (Hulled)		10	2	4	8	11	13	17	20	23
ANNUAL RYE GRASS		10	1	2	4	6	8	11	12	14	LESPEDEZA (Unhulled)		10	1	3	5	8	11	14	17	19
BIRDSFOOT TREFOIL		10	2	5	8	11	17	20	25	29	LOVE GRASS (Sand)		10	2	4	6	9	12	15	19	22
BLUEGRASS (Kentucky)		10	1	2	2	4	5	6	8	8	LOVE GRASS (Weeping)		10	1	5	8	11	14	17	21	25
BLUEGRASS (Park Kentucky)		10	1	2	4	6	8	11	12	14	MILLET		10	2	5	8	11	14	17	21	25
CANOLA		10	1	4	6	10	12	14	17	20	ORCHARD GRASS		10	-	1	2	2	3	4	5	5
CLOVER (Crimson)		10	2	4	6	10	14	16	19	24	RED TOP		10	1	2	3	4	5	6	7	8
CLOVER (Ladino, Sweet, Red)		10	2	5	8	11	14	17	19	23	REED CANARY GRASS		10	1	2	3	5	6	8	9	11
KLEIN GRASS		10	2	4	8	11	14	19	23	25	TIMOTHY		10	2	3	5	9	11	14	17	20

**Figure 4-26: 10" Grass Seed Rate Chart**

## Small Seed Meter Assembly/Adjustment

1. If the small seed meter shaft assembly is disassembled for maintenance or repair, the seed meters and seed rate adjustment will need to be reset or zeroed to set the meters equally across the seed box.
2. To reset the seed meters, remove all seed, chaff, and dirt from the seed box and seed meters *See Figure 4-27*. Reassemble the meters and drive shaft assembly, but leave the locking set collars, meter feed rolls and meter cut-offs loose on the shaft. Leave the drive chain disconnected as well.
  - a. Set the seed rate adjusting nut to "0A", and tighten the large locking nut against the right side of the seed shaft bearing. The two smaller 1/2" locking nuts should be tight against the threaded adjusting screw as well.
  - b. For each seed meter, slide the meter feed roll and cut-off to the right to fully close each meter. Slide the locking collar on the left side of each meter against the meter cut-off and tighten the lock collar.
  - c. For each seed meter, slide the right locking set collar next to the meter feed roll (leaving .010"-.020") of clearance and tighten the set collar. Make sure the flutes on the meter feed roll are lined-up and inserted in the meter housing.
  - d. Rotate the square seed shaft by hand to verify the shaft is not binding and rotates freely.
  - e. Loosen the large locking nut against the seed shaft bearing. Adjust the seed shaft in and out to make sure all meter feed rolls are properly aligned and not binding. Do not force the adjustment or damage will occur to the meter assembly.
  - f. Reconnect the drive chain.
  - g. Set the seed rate adjustment to the desired rate and tighten the locking nut.
3. The seed meters should now be reset to zero, and match the zero indication on the adjusting screw.

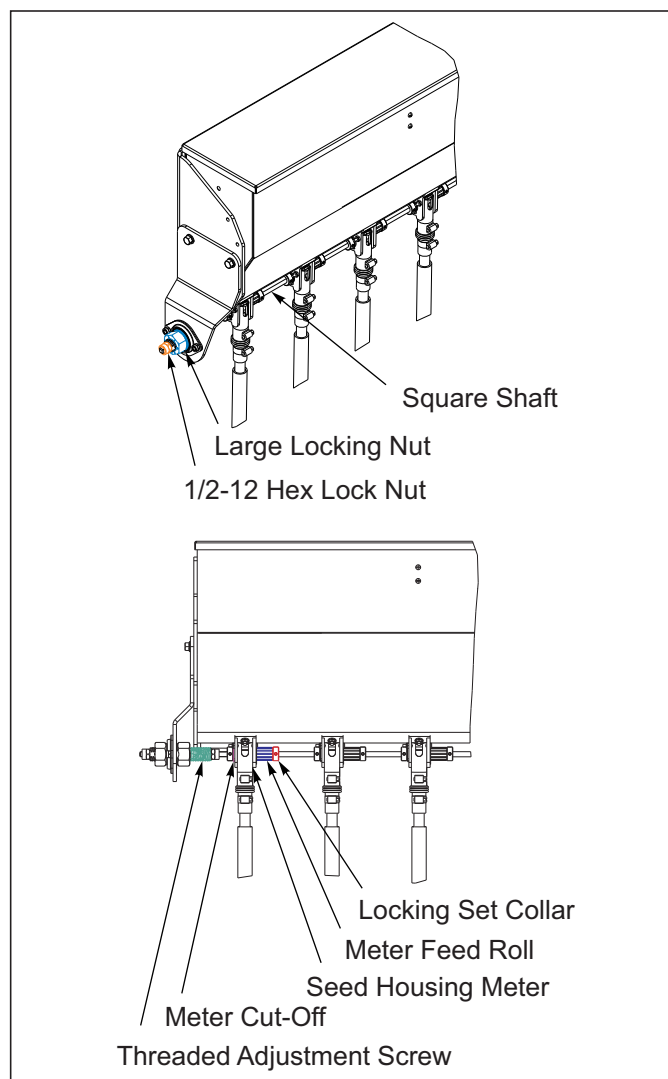

**Figure 4-27: Small Seed Rate Adjustment**

## **Small Seed Disconnect**

1. To disconnect the small seed box, locate the seed drive sprocket at the front and outer end of the seed boxes. Drills equipped with the optional small seed attachment have a quick disconnect installed on the seed shaft. This allows the operator to disconnect the small seed box drive for each section when not in use, and just use the main seed box.
2. On Models 5211-15'-20' it will be in the middle of the section. Pull the T-handle out and rotate the lock pin 90 degrees. To engage the seed drive pull out and rotate the T-handle until the handle aligns with the groove in the pin. Rotate the seed shaft by hand, until the lock pin engages the sprocket. Verify that the small seed drive is rotating when starting planting.

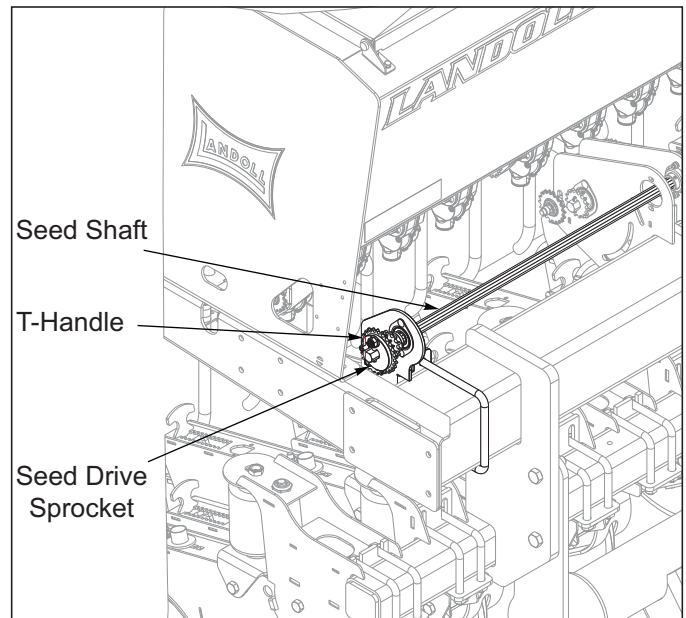

**Figure 4-28: Small Seed Disconnect**

## Air Spring Adjustment

1. The air pressure delivered to the air springs is the same for all openers. To be able to increase the down pressure for specific row units such as in wheel track locations, the air spring has two mounting positions. The normal position is forward, with a heavier setting by sliding the air spring to the rear. The heavier setting will increase the down pressure by approximately ten percent.



### CAUTION

Relieve system air pressure before attempting to adjust or service any air spring component. Make sure all components are in place and secure before charging the system.

2. To adjust the air spring location, first relieve the system air pressure. Loosen, but do not remove the 3/4-16 hex jam nut at the top of the air spring and the 1/2-13 x 1 hex head cap screw below the air spring and air spring pivot. Slide the air spring forward or rearward to the desired location *See Figure 4-29*.

### IMPORTANT

Make sure the air spring has fully reached the ends of the top and bottom slots before retightening. If the air spring is not in the ends of the slot, it will be out of alignment and can rub internally wearing a hole. Also, be sure the air spring is not twisted when re-tightening the fasteners.

3. Re-tighten the top jam nut and bottom hex head cap screw to secure the air spring. Recharge the system with air to normal working pressure.

### NOTE

Maximum torque on the top jam nut is 30 ft. lbs.

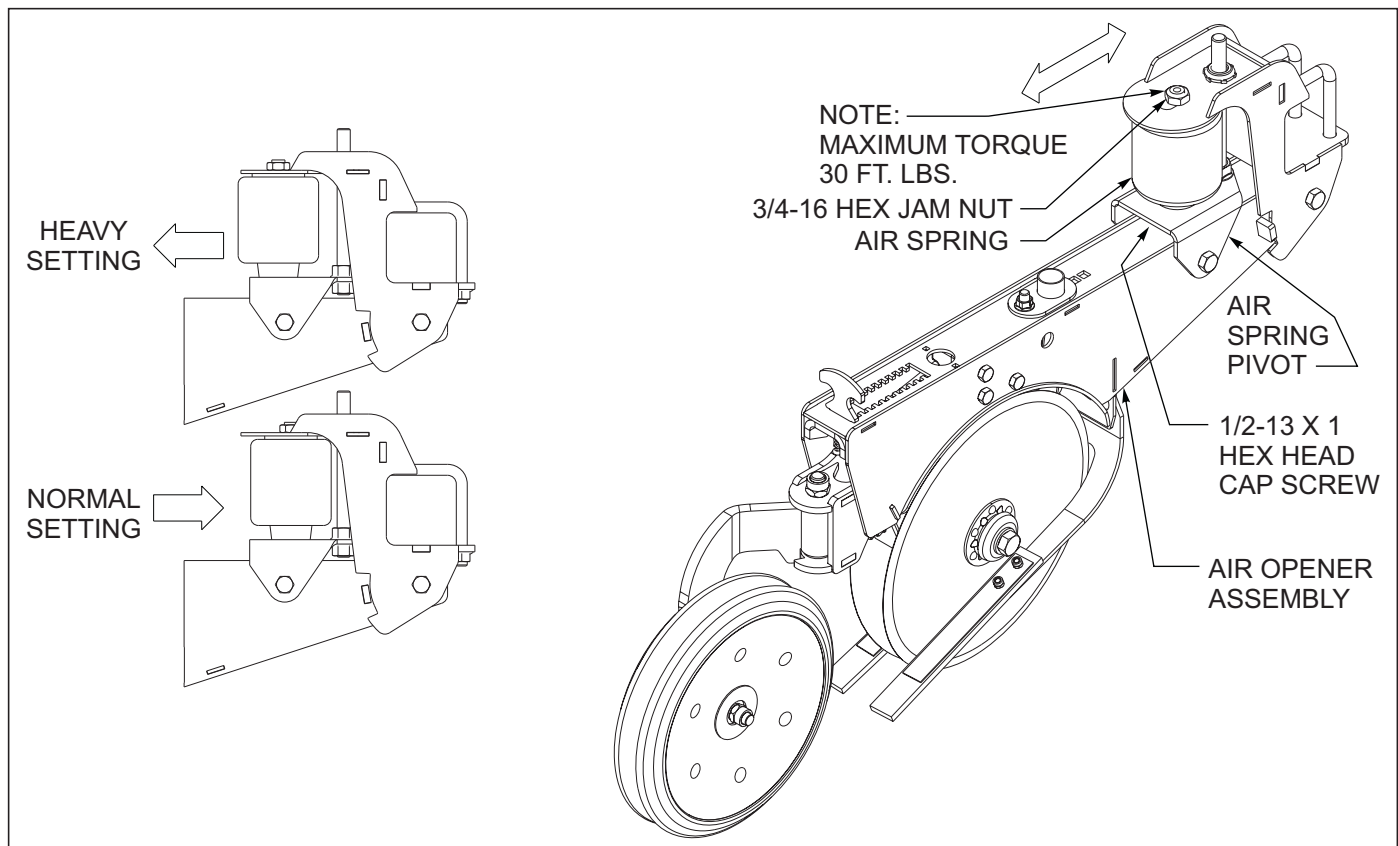

**Figure 4-29: Air Spring Adjustment**

## Opener Blade Adjustment

1. To insure peak performance of the opener assembly and maximum bearing life a proper opener blade pinch point should be maintained. The pinch point of the blades is the lower front point where the right and left opener blade come in contact with each other, and enter the ground. *See Figure 4-30*

**DANGER**

**Opener blades are extremely sharp. Exercise extreme care when working on or near opener blades. Do not allow opener blades to roll over or fall onto any body part. Do not allow wrenches to slip when working near blades. Never push wrenches toward opener blades. Do not climb over machine above opener blades. Failure to stay clear of opener blade edges can cause serious personal injury or death.**

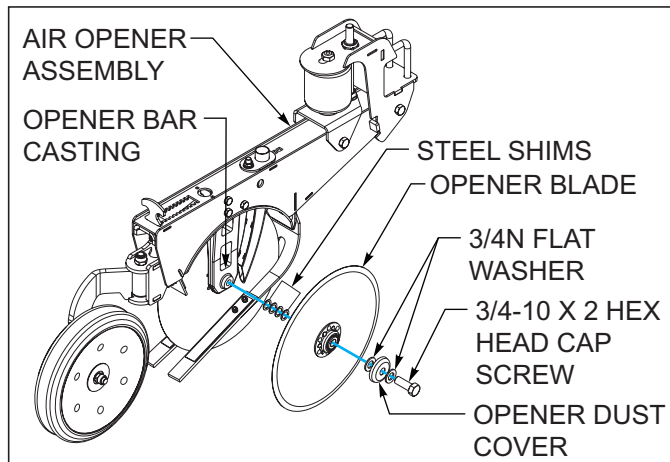

**Figure 4-30: Opener Blade Adjustment**

2. A properly maintained pinch point will allow the opener to penetrate better and create a smoother seed trench for better seed placement. A pinch point that is too wide will allow soil/mud to build up between the opener blades regardless of how the scraper may be adjusted. A pinch point that is too wide or too narrow can excessively preload the opener bearings and lead to premature bearing failure, particularly in heavy soils or no till applications.
3. The pinch point is adjusted by adding/removing shims from between the opener blade and opener casting *See Figure 4-31*. When removing shim(s) from between the blade and the casting, move them to the outside of the blade and place under the dust cap. Do not discard shims. This will keep track of the shims and not change the length of bolt required. Adjust the shims as equally as possible so there are similar number of shims under the right and left blades.

Example 3 & 3, or 3 & 2.

Opener blades must turn freely and not bind.

Opener blades must maintain contact at pinch point while rotating.

The amount of pinch point contact can be verified by inserting a .015" thick shim (business card) above and below the pinch point where the blades meet. Measure the distance between the two shims at the edge of the disc blade. Rotate blades 1/2 turn to recheck the pinch point distance. Average distance should be between 1-1/2" and 2-1/2".

If the distance is not within the specified range, adjust by adding or removing shims to inside of the opener disc blade assemblies.

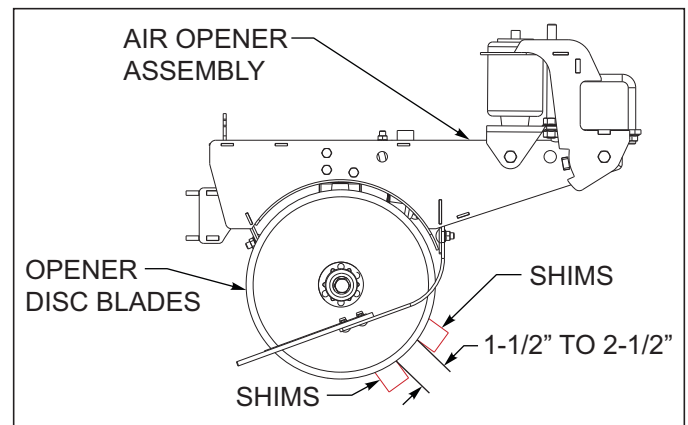

**Figure 4-31: Opener Blade Pinch Point Adjustment**

4. As the opener blades wear, it will be necessary to adjust the pinch point to maintain the pinch point. No till planting applications will generate more wear and more frequent pinch point adjustment.

## Opener Blade Wear

New opener blade diameter is 15-3/4" (400mm). Typical blade wear life is 1". Replace the opener blade if the diameter is less than 14-3/4" (375mm) or uneven seed depth occurs. Operating blades below this diameter will limit planting depth and adjustment. Opener blade pinch point should be maintained throughout the life of the blade. Blade wear below the 14-3/4" diameter can lead to interference with the seed tube and scraper and inability to maintain the pinch point.

## Opener – Press Wheel Adjustment

1. The seeding depth of each individual opener is controlled by the press wheel depth adjustment **See Figure 4-32**. To change the depth of each press wheel, raise the openers so there is not any weight on the press wheel. Pull up on the adjusting handle and slide the depth stop forward or rearward to obtain the desired seeding depth. Each notch represents approximately 5/16" in depth. Slide the handle forward for shallower seed placement, and rearward for deeper seed placement.

### **NOTE**

***Increasing opener down pressure does not increase seed placement depth.***

2. As long as the press wheel is carrying weight, the seeding depth is regulated by the press wheel adjustment. An increase in down pressure does not change the depth of seed placement.
3. Make sure the hitch is level when planting to insure consistent planting depth. A hitch that is too high or too low can change how the press wheel contacts the ground and affect seeding depth.

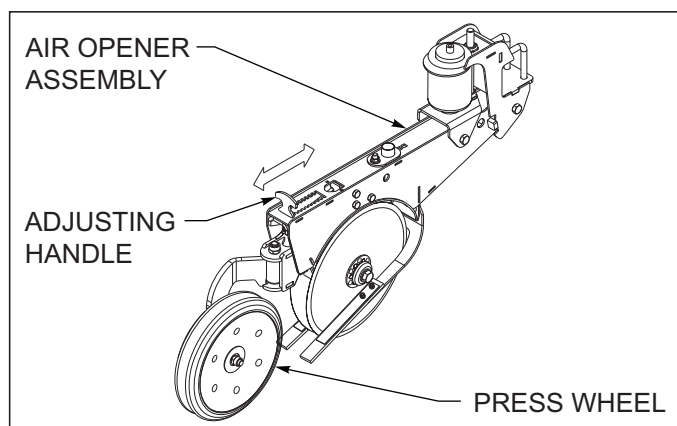

**Figure 4-32: Press Wheel Adjustment**

## Opener Scraper Adjustment

1. The opener is equipped with a scraper to keep the inside surfaces of the opener blades clean. In dryer conditions, the scraper can be adjusted farther away from the opener blades for greater clearance. In wetter conditions, it will be necessary to adjust the scraper blade closer to the opener blade.



### **CAUTION**

**Opener blades are very sharp. Use gloves when working around opener blades.**

## TABLE OF CONTENTS

2. To adjust the scraper blade, loosen the 1/2-13 hex flange spirallock nut holding the blade, and slide the blade up or down to achieve the desired clearance **See Figure 4-33**. Re-tighten the 1/2-13 hex flange spirallock nut. Carefully rotate the opener blades to make sure the blades will turn freely and not drag on the scraper.
3. A properly maintained opener blade pinch point will reduce the amount of soil that enters between the opener blades. This will in turn allow the scraper to operate in a cleaner environment and reduce scraper wear. Pinch point adjustment **See Figure 4-31**.

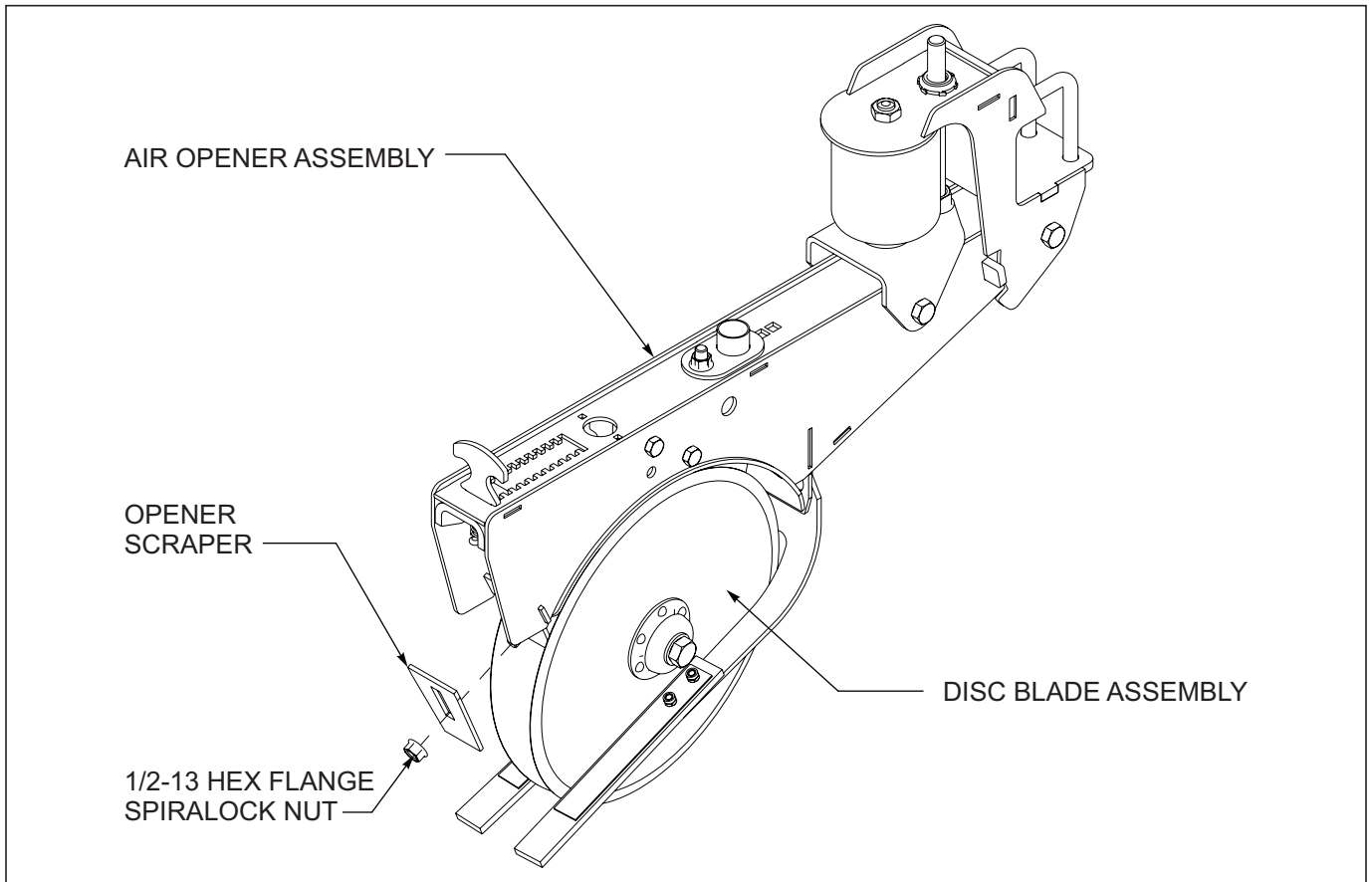

**Figure 4-33: Opener Scraper Adjustment**

## Opener Soil Strip Adjustment

1. The soil strip runs along the side of the opener blade to reduce soil blow out of the seed trench. This will allow the soil to stay in position for more consistent filling of the seed trench and uniform coverage.
2. The opener should first be set for the desired planting depth and press wheel adjustment. The soil strip should then be adjusted for slight pressure with the ground where the opener blade is leaving the seed trench. Excessive down pressure on the soil strip will increase wear and can cause plugging issues. The soil strip should be set to run parallel with the opener with an approximate 1/16" gap. The soil strip should not be set so tight to the opener blade that will drag or prevent the opener blade from turning freely.

3. The metal backing strip should be centered over the soil strip. Do not allow the metal backing strip to rub against the opener blade or it will tend to trap residue.



### CAUTION

**Opener blades are very sharp. Use gloves when working around opener blades.**

4. To adjust the soil strip, loosen the 1/2-13 hex flange spirallock nut at the front of the soil strip bracket **See Figure 4-34**. The bracket may be adjusted up or down to the desired height and side to side to center on the opener blades. Retighten the 1/2-13 hex flange spirallock nut.

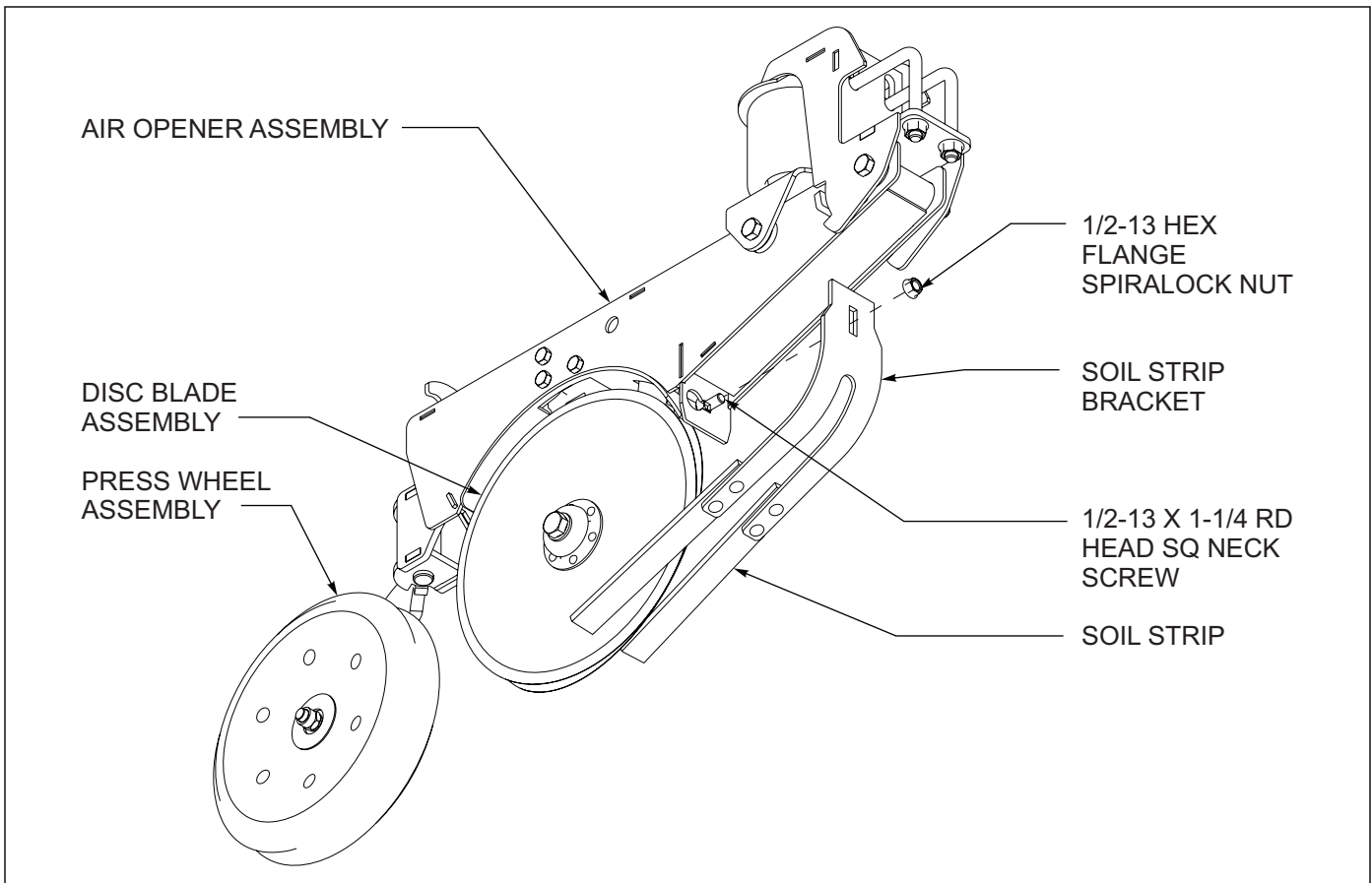

**Figure 4-34: Opener Soil Strip Adjustment**

## Spring Opener

1. The 5211 may be equipped with a spring opener. This opener has two 15.8" (400mm) x .138" (3.5mm) opener blades, rigid scraper, and adjustable non-swivel press wheel. The opener has 10" of vertical travel. Spring openers may be equipped with optional soil strips.
2. The spring opener has two spring settings for light or heavy down pressure **See Figure 4-35**. The lower spring mounting hole at the rear of the spring is the heavy setting, and the upper hole is the light setting. The light setting will be approximately 10% lower than the heavy setting. To change the spring pressure setting, raise the opener slightly off the ground to relieve the spring pressure. Remove the ½-13 x 3-3/4 cross-bolt through the rear of the spring assembly. Move the spring to the desired setting and reinstall the cross-bolt.

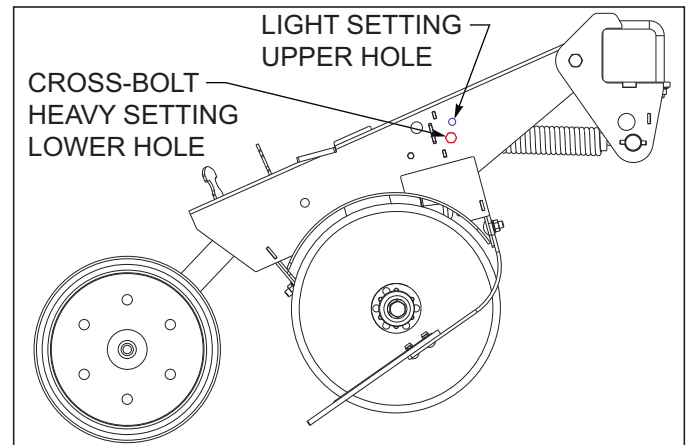

**Figure 4-35: Spring Opener Assembly**

## Walkboard

1. The walkboard on the Grain Drill provides a stable platform to work from while filling the seed box **See Figure 4-36.**



### WARNING

Do not allow anyone to stand, ride, or climb on the walkboard while the drill is in motion.

2. The walkboard may be raised to allow easier service access to the openers. To raise the walkboard, lift at the center rear of the wallboard and rotate forward. A latch is provided to hold the walkboard in the raised position.
3. To lower the walkboard, release the latch at the end of the walkboard, and slowly lower to a level position.

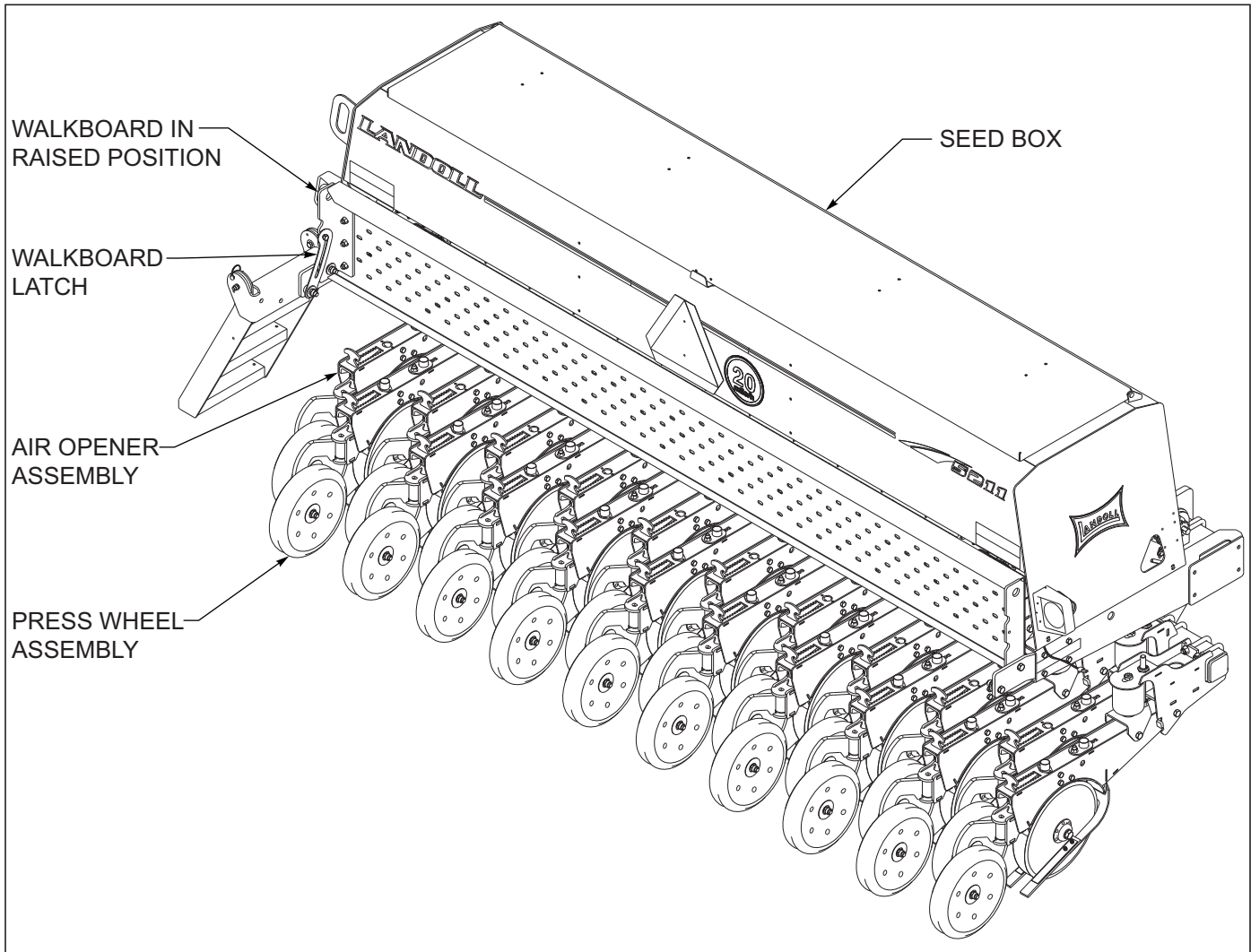

Figure 4-36: Walkboard Adjustment

## Ladder Use and Transport Requirements

1. When transporting the 5211 Grain Drill:
  - a. The ladder should be in the raised position (laying across the top of the walkboard) and secured with the pin **See Figure 4-37.**
  - b. The ladder should also be in the raised position when working in the field to prevent damage when working near trees, fences, power lines, etc.
2. When using the ladder:
  - a. Lower ladder to the down position and place pin in the storage location to gain access to the seed boxes **See Figure 4-38.**
  - b. A handle is provided on the end of the drill for access.



### **WARNING**

Never allow riders on the ladders or walkboards while the drill is in operation or being transported.

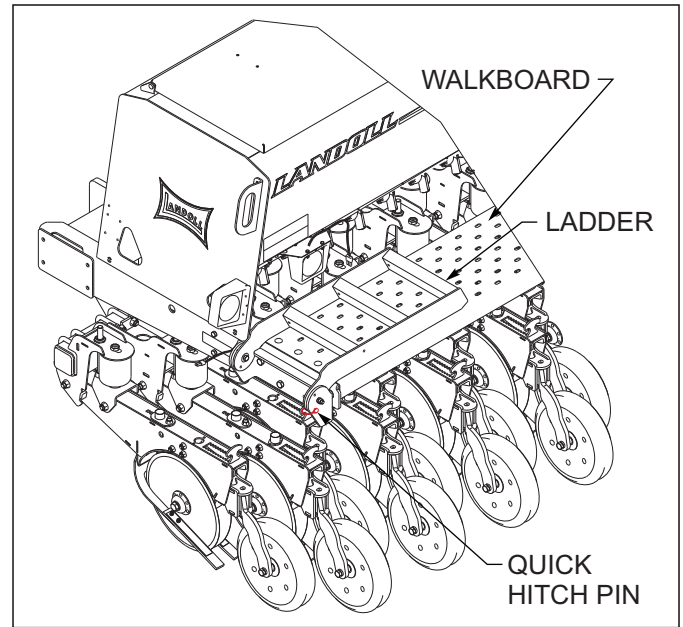

**Figure 4-37: Ladder Location During Transport/Planting**

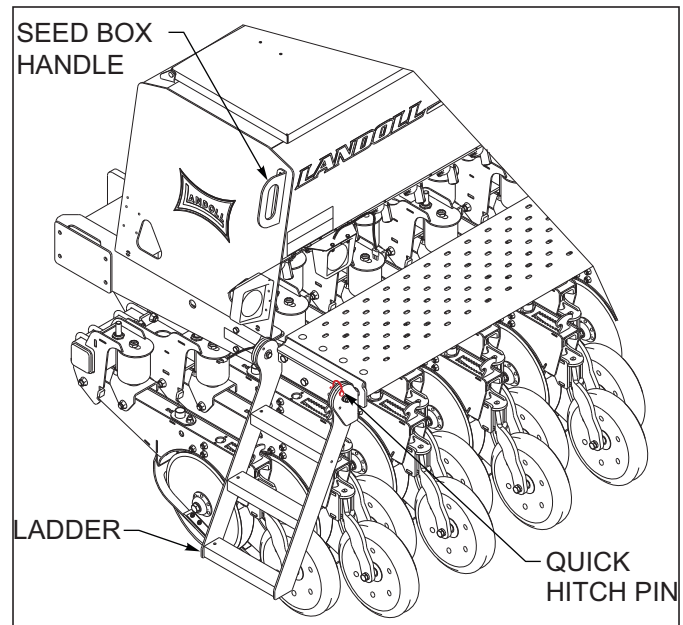

**Figure 4-38: Using the Ladder**

### Hydraulic Row Markers (Option)

1. The Grain Drill may be equipped with optional hydraulic row markers. This will require an additional tractor remote to operate the markers.



#### **DANGER**

**To prevent injury or death, stay clear of markers while folding/unfolding. Hydraulic failure can allow markers to raise or fall suddenly.**



#### **DANGER**

**To prevent injury or death from electrocution: stay away from power lines while transporting, folding, or unfolding markers. Electrocution can occur without direct contact of power lines.**

2. To operate the markers, lower the drill so that it is in planting position. Never attempt to fold/unfold the markers with the drill in the transport position.

3. With both markers in the raised position, slowly engage the marker hydraulics. One marker will extend. Reversing the hydraulic lever will raise that marker.
4. Slowly engage the marker hydraulics again and the opposite marker will extend.
5. Reverse the marker hydraulics again and that marker will rise.
6. The marker unfold/fold process will then repeat itself.



#### **CAUTION**

**Marker blades are very sharp, use gloves when working around marker blades.**

7. Insure that the marker hydraulic system is full of oil before attempting to fold or unfold the markers. If a hydraulic component is removed, repaired, or replaced the system must be purged of air before folding/unfolding the markers. To purge the system of air, unpin the rod end of both marker cylinders. Align or prop the cylinders into position so that the rod will not interfere with anything during its travel. Slowly engage the tractor hydraulics fully extending and retracting both marker cylinders. Repeat several times until the action of both cylinders is positive and immediately responsive. Do not loosen or crack any fittings. Reconnect the rod end of both cylinders.

## Hydraulic Row Marker Disc Adjustment (Option)

**! CAUTION**

**Marker blades are very sharp. Use gloves when working around marker blades.**

1. The marker disc blade may be adjusted to vary the mark left in the field.
  - a. The disc angle may be adjusted to leave a wider or narrower cut. The steeper the angle the wider the cut will be *See Figure 4-39.*
  - b. Loosen the 1/2-13 x 3-1/2" round head square neck screws that attach the spindle assembly to the extension tube marker weldment.
  - c. Rotate the marker blade assembly as desired and re-tighten the mounting bolts.

2. The disc blade may also be configured to push or pull soil towards the drill.
  - a. To change the direction of the disc blade, first remove the 4 bolts and dust cap retainer from each hub assembly.
  - b. Remove the two 1/2-13 x 3-1/2" round head square neck screws that attach the spindle assemblies to the extension tubes.
  - c. Swap the spindle and hub assemblies with the right and left markers.
  - d. Using the 1/2-13 x 3-1/2" round head square neck screws, attach the spindle assemblies to the bottom of the extension tubes.
  - e. Change the direction of the marker disc blade and reinstall the 4 mounting bolts and dust cap retainer.
3. To adjust the cutting width of the marker disc, loosen the u-bolt that secures the extension tube to the outer arm assembly.
4. Slide the extension tube in or out to the desired position and retighten the u-bolt.
5. Pull the drill a short distance and verify adjustment.

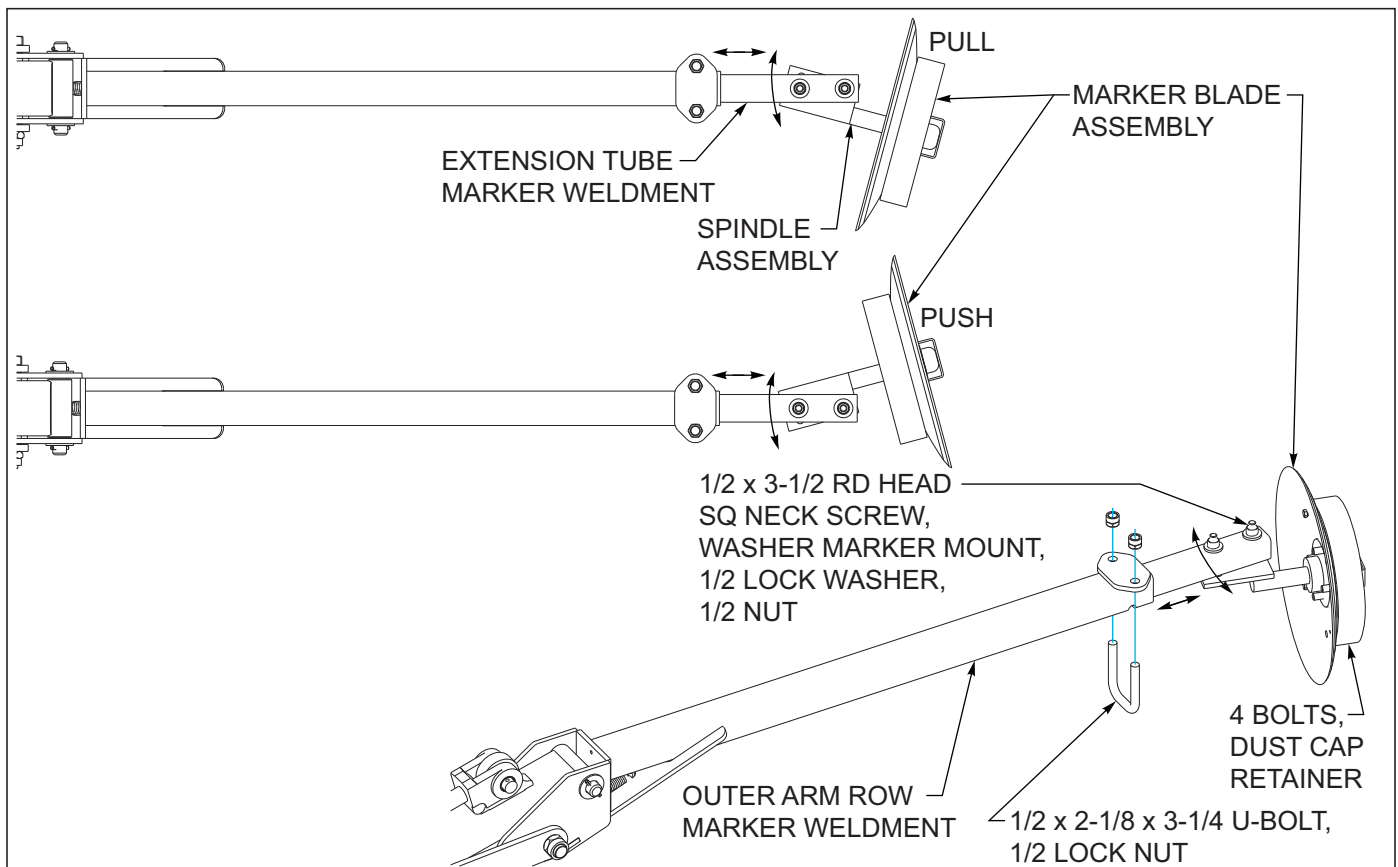

**Figure 4-39: Hydraulic Row Marker Adjustment**

## Coulter Hitch (Option)

1. The Grain Drill may be equipped with an optional coulter hitch **See Figure 4-40**. Coulters may be used to provide additional tillage in front of the openers. The coulters operate on a separate hydraulic remote which operates independently of drill. A reference depth gauge is located on the left side of the hitch for coulter depth.
2. Operation - The drill may be operated with or without the coulters lowered to the ground. When turning with the drill, the main drill lift hydraulics should allow the coulter gangs to clear when turning without having to

operate the coulter hydraulics.

3. The amount of down pressure needed to operate the coulters will vary with soil conditions, moisture and residue. For accurate seeding depth you must adjust the drill and coulter depths to match the current soil conditions. Be careful not to operate the coulters too deep, particularly in wet conditions. Coulters can throw/remove too much soil in front of the opener that the opener may not be able to properly close the seed trench. Excessive coulter down pressure in dry/hard conditions can raise or limit the travel of the openers creating inconsistent planting depths.

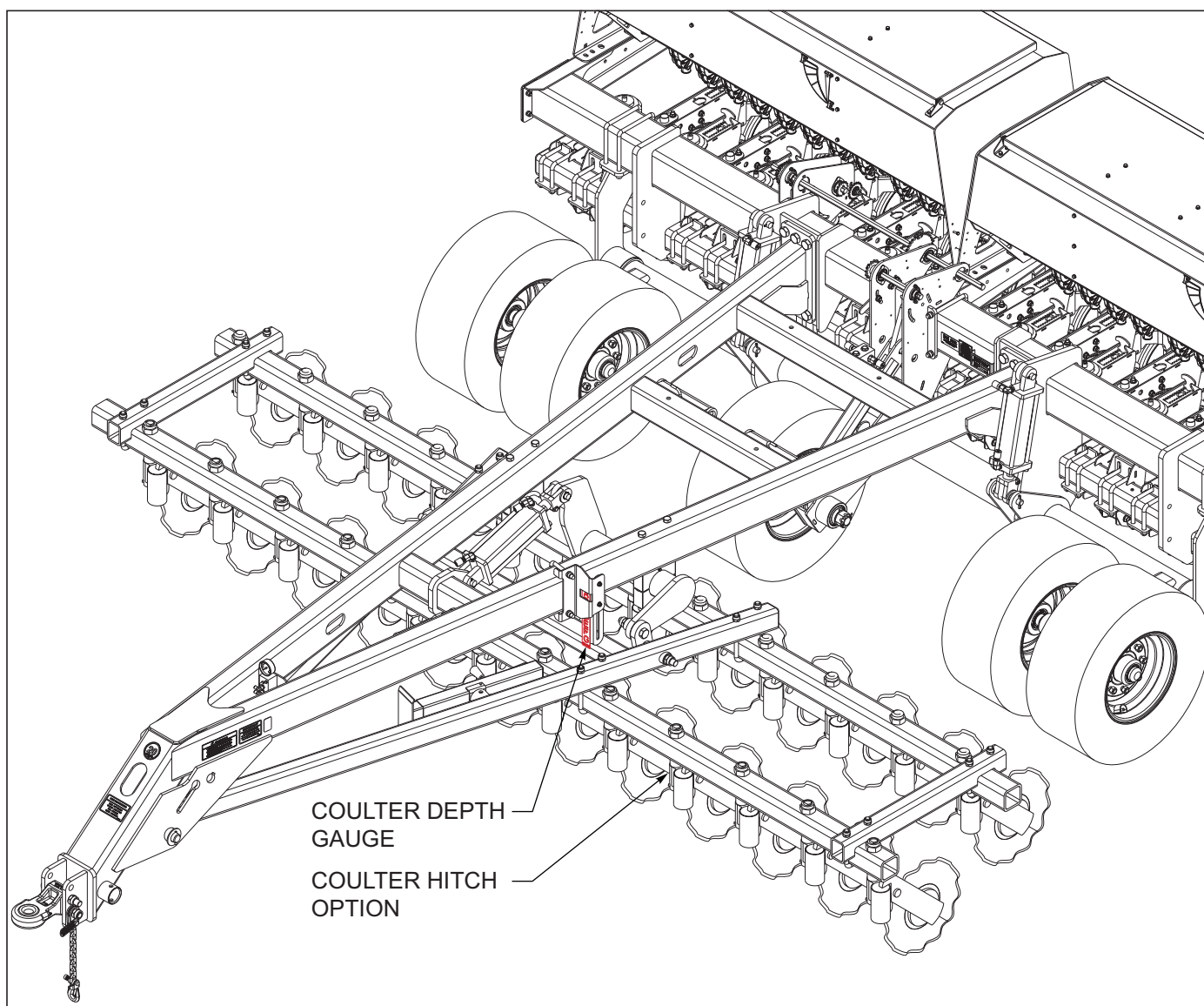

**Figure 4-40: Coulter Hitch**

### 3 Point Hitch (Option)

1. The 5211 may be equipped with a 3 point hitch versus a pull hitch *See Figure 4-41*. The 3 point hitch is a standard width CAT III hitch and will attach to any tractor with a CAT III hitch or quick hitch.
2. Drills equipped with the 3 point hitch will be equipped with drive wheels at each end of the main frame. The drive wheels will be used to gauge the depth of the grain drill openers when in the field. For initial adjustment, the bottom of the 4 x 4 toolbar should be approximately 19" above the ground. Seeding depth and ground conditions can vary this measurement.

Raise or lower the seeding depth by extending/retracting the ratchet jack assembly on each drive wheel. Measure the pin-to-pin length of both ratchet jacks and set them the same so the unit depth will be even.

3. Some drills will drive the seed boxes from both drive wheels, other drills will only drive from one end. It is important to keep the drive wheels in contact with the ground while seeding. Failure to maintain ground contact will result in seeding skips. Raise the drill when turning to prevent side loading and damage to the openers and drive wheels.

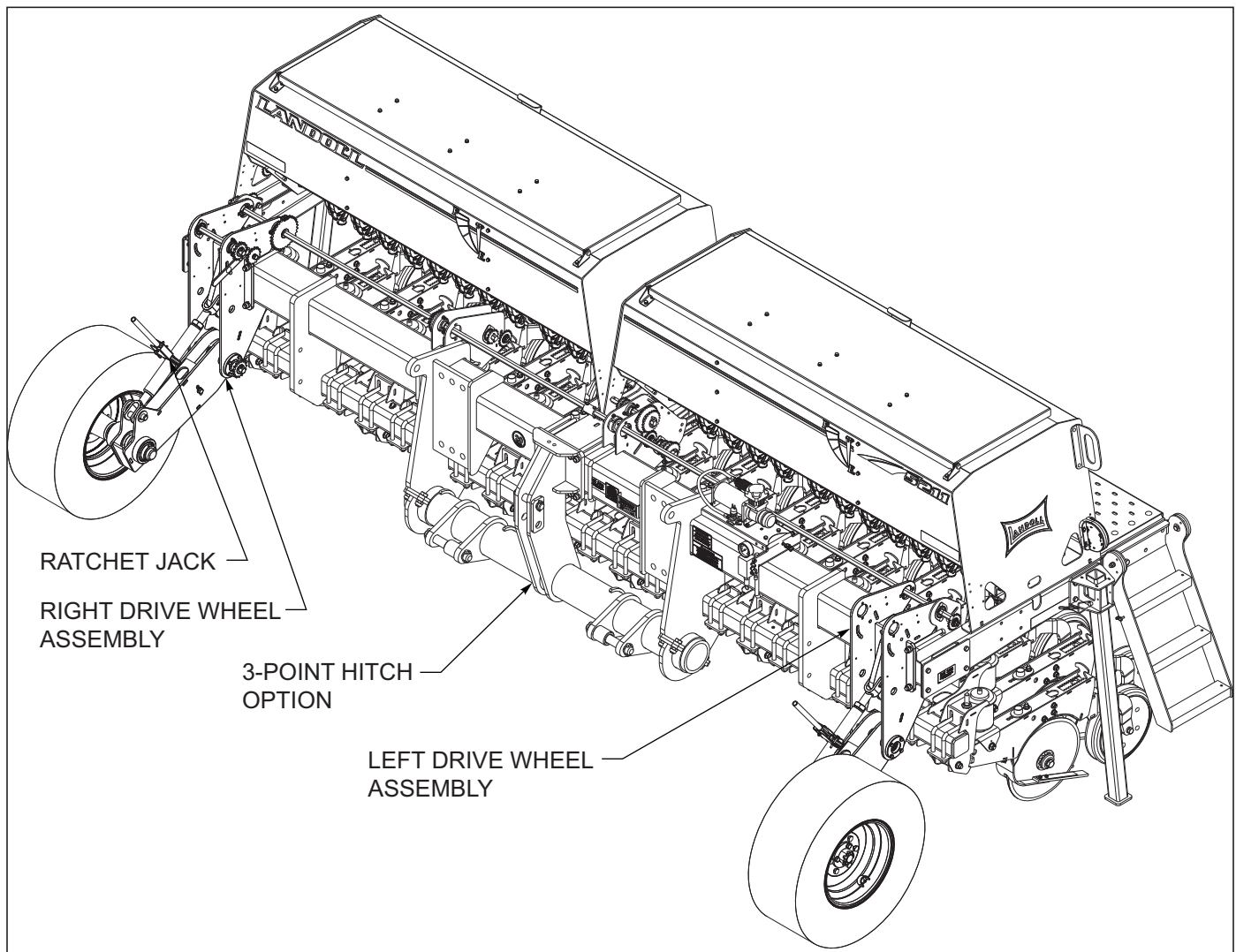

**Figure 4-41: 3 Point Hitch**

### Loup Mini Drill Monitor Operation (Optional)

1. The 5211 Grain Drill can be equipped with an optional Loup Mini drill monitor. The drill monitor will monitor population from two sensors on each box, seed box levels on each seed box, as well as acres planted.
2. Population readings are 95% accurate for soybeans. When planting smaller seeds the population accuracy will be reduced. This does however give you a reliable indication that all sections are planting. The monitor may be adjusted to set high/low population alarms. Do not use the monitor to calibrate the seeding population. To calibrate the drill either by weight or seed count, see **“Seed Rate Calibration” on page 4-14.**
3. Bin level sensors are installed in each seed box. When the sensor is submerged in seed, no alarm will sound. As the seed level falls below the sensor eye, an alarm will be indicated on the drill monitor. The bin level sensor is mounted to an adjustable bracket. The bracket may be raised or lowered to the desired level in the seed box.
4. The drill monitor will also monitor field and total acres.
5. Pulses are preset for the drill monitor. Initially the pulses are set at 68. The pulse setting may vary depending on the conditions the drill is planting in. Worked or loose sandy soils will have a different setting than firm no till conditions. For greater accuracy on the pulse setting, calibrate the drill monitor in the desired working conditions. This is done by driving a known distance (400 ft) and recording the number of pulses in that distance. Refer to the Loup manual for instructions.
6. The drill monitor is operated on a 12-volt dc negative ground system. The monitor may be connected using the existing connection, or may be hard-wired to the appropriate connections. Connect the red wire to a positive terminal that is on when the tractor switch is on. Connect the black wire to a chassis ground on the tractor maintaining good metal-to-metal contact.
7. The signal cable attaches to the monitor and connects to the drill. The cable may be plugged/unplugged at the front of the drill hitch when hooking/unhooking the drill. This allows the monitor to stay in the tractor if so desired.

8. For service or setup questions, please refer to the Loup Mini Drill Monitor manual, or contact Loup Electronics:

Loup Electronics Inc.  
2960 N. 38<sup>th</sup> Street  
Lincoln, NE 68504  
877-489-LOUP(5687)  
info@loupelectronics.com

### Battery Operated Acre Counter Operation (Optional)

The battery operated acre counter operates in one of two modes. In sleep mode, the display is blank, and the counter is accumulating acres. Sleep mode will be entered if a button is not pressed for 20 seconds. In entry mode, the display is on, and the operator can enter values. To get into entry mode, press the **FUNC** button (designated by a \* at the lower left side of the console). If you continue to press the **FUNC** button, the acre counter will cycle through the functions that it can perform. The LEDs above the display indicate which function is selected **See Figure 4-42.**

The available functions are:

- a. Field Acres
- b. Total Acres
- c. Pulses per 400 ft (Distance Traveled)
- d. Width
- e. Password
- f. Low Battery

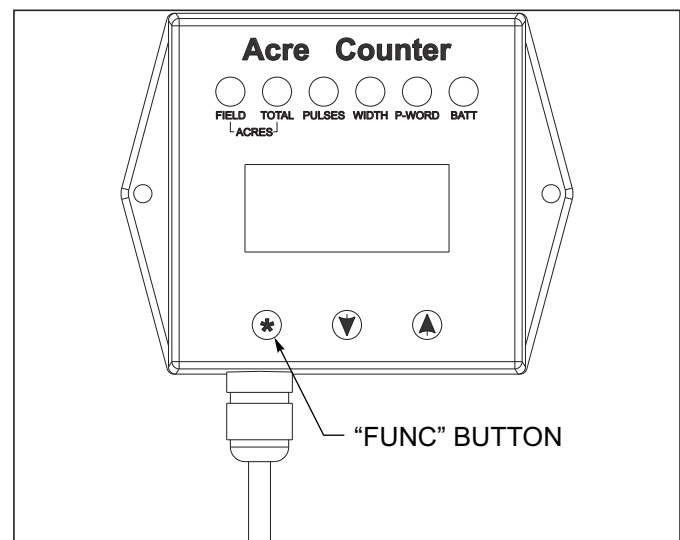

**Figure 4-42: Acre Counter Console**

## Field Acres

1. Press the FUNC button until the “**FIELD**” LED is lit. The digits indicate the acres covered since the field acre counter was cleared *See Figure 4-43.*
2. To clear the field acre count, press the **UP** and **DOWN** buttons simultaneously for two seconds. If a password has been entered, you will not be able to clear the total acre count.
3. Field acres will count in tenths of an acre up to 9999.9 acres.

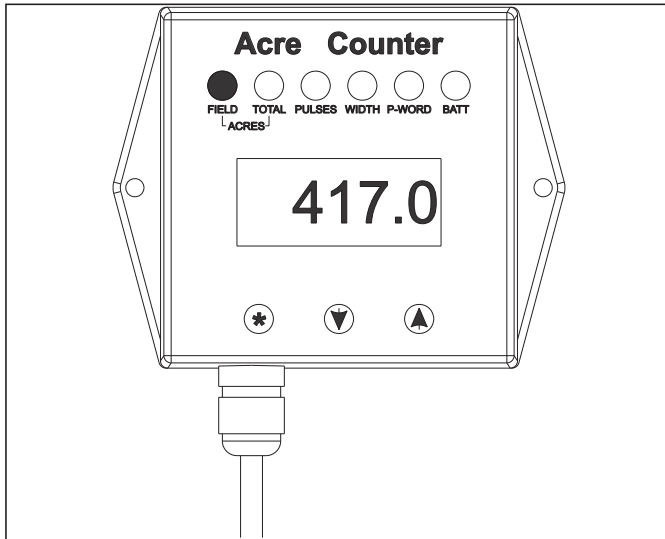

Figure 4-43: Field Acres Display

## Total Acres

1. Press the **FUNC** button until the “**FIELD**” and “**TOTAL**” LEDs are lit. The digits indicate the acres covered since the total acre counter was cleared *See Figure 4-44.*
2. To clear the total acre count, press and hold the **UP** and **DOWN** buttons for two seconds. If a password has been entered, you will not be able to clear the total acre count.
3. Total acres will count from .1 to 99999 acres.

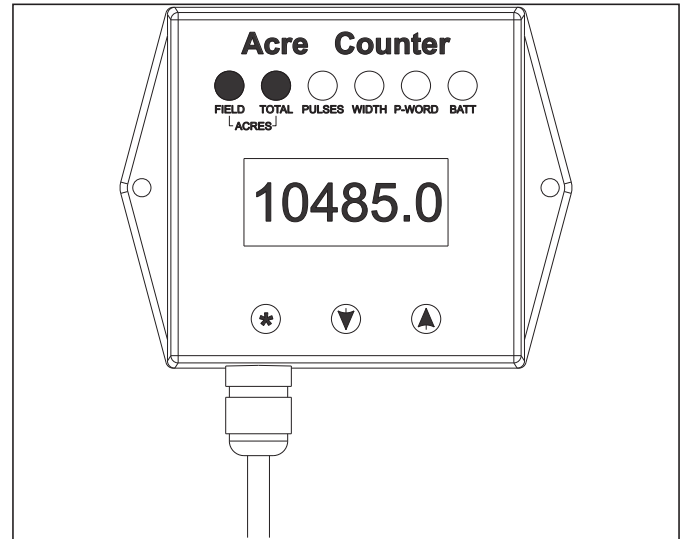

Figure 4-44: Total Acres Display

## Pulses per 400 Feet

Press the **FUNC** button until the “**PULSES**” LED is lit. The number in the display indicates how many pulses are generated for every 400 feet driven. *See Figure 4-45.*

1. For the 5110NG Grain Drill, set the pulses per 400 feet to 17 by using the **UP** and **DOWN** buttons. When you press the **FUNC** button, the Acre Counter will accept the number in the display as the new pulses per 400 feet.

### NOTE

*If a password is set, you will not be able to adjust the pulses per 400 feet.*

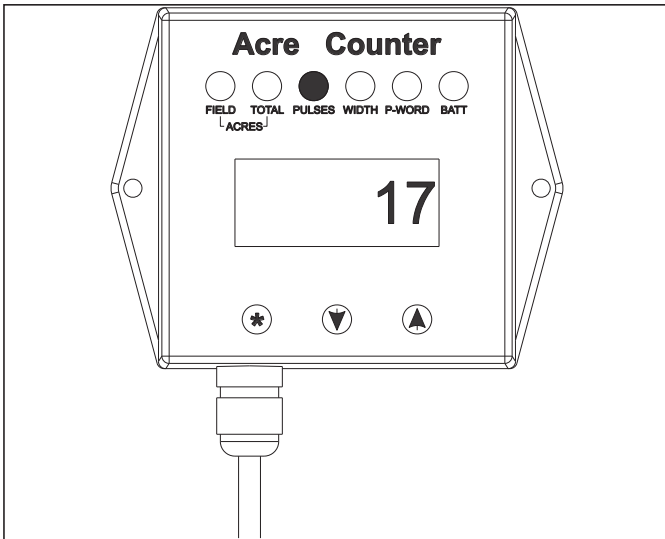

**Figure 4-45: Pulses per 400 Feet Adjustment**

## Width

1. Press the **FUNC** button until the “**WIDTH**” LED is lit. The number displayed is the length of your implement in feet *See Figure 4-46.*
2. To adjust the width, press the **UP** and **DOWN** buttons. If a password has been entered, you will not be able to adjust the width.
3. The width can be adjusted from .1 to 99.9 feet, in tenths of a foot.

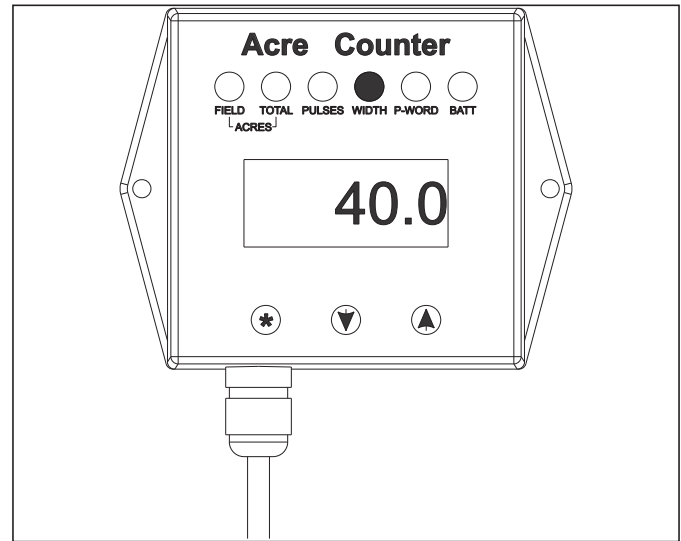

**Figure 4-46: Drill Width**

## Password

The password function allows you to protect the total acre count, pulses per 400 feet, and width settings with a password. This stops anyone from accidentally changing those settings. When the acre counter is shipped, the password is disabled. You can modify the pulses per 400 feet and implement width at any time.

Press the **FUNC** button until the “**P-WORD**” LED is lit. The digits will display the word “**Ent**” or “**dIS**”.

1. If the display shows “**dIS**” *See Figure 4-47.*

The password is disabled. The total acre count, pulses/400 ft, width, and password settings can be adjusted using the **UP** and **DOWN** buttons. The password can also be changed using the **UP** and **DOWN** buttons.

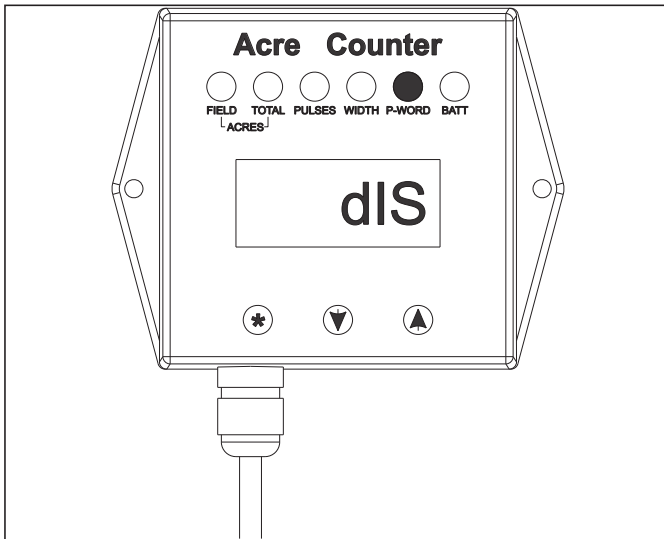

**Figure 4-47: Password Disabled**

2. If the display shows “**Ent**” *See Figure 4-48.*
  - a. You must enter your password using the **UP** and **DOWN** buttons. When your password is displayed, press the **FUNC** button to test the password. If the password is correct, you will be able to change the acre counter settings. The password will be viewable until the acre counter powers down. When the acre counter is powered up again, you will have to re-enter the password to change settings.

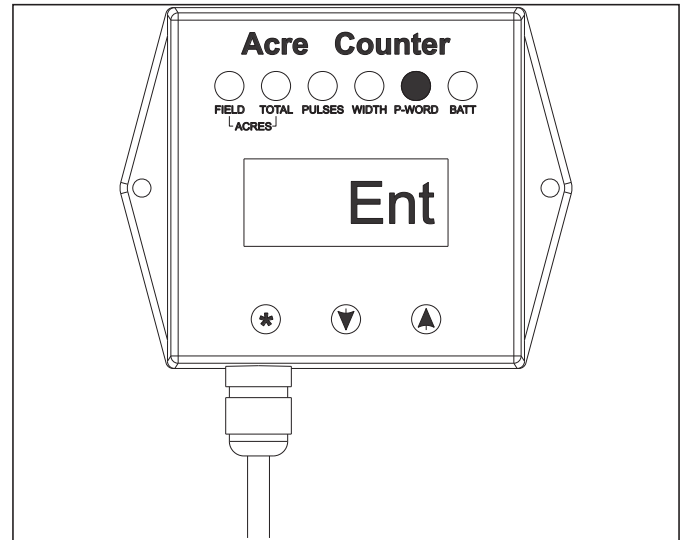

**Figure 4-48: Enter Password**

- b. If the password is not correct, you will not be able to change the acre counter settings. When the “**P-WORD**” function is selected again, “**Ent**” will appear in the display.

## Changing the Password

Select a new password using the **UP** and **DOWN** buttons. Press the **FUNC** button until the word “**SEt**” appears in the display *See Figure 4-49*. Release the **FUNC** button. The number in the display is your new pass code. Make sure you write it down! Press and hold the **FUNC** button until the word “**dis**” appears in the display.

### **NOTE**

*If the password is forgotten, it can be disabled by removing the batteries. The password is intended for rental units. It is recommended that a seal be affixed to the rear plate of the acre counter to determine if the settings have been tampered with.*

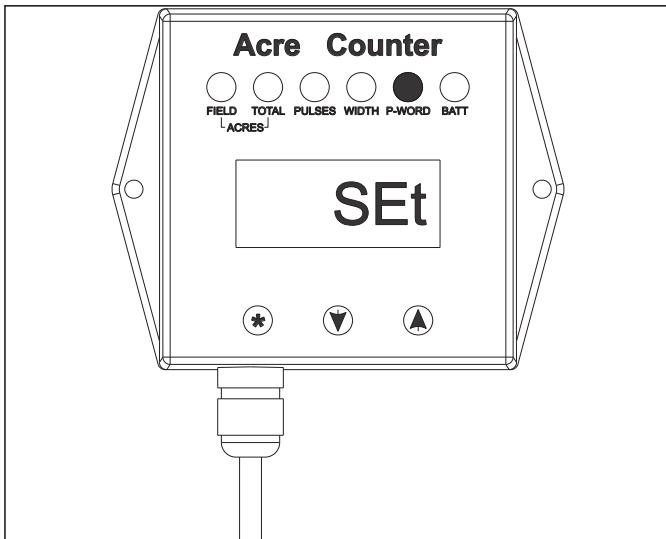
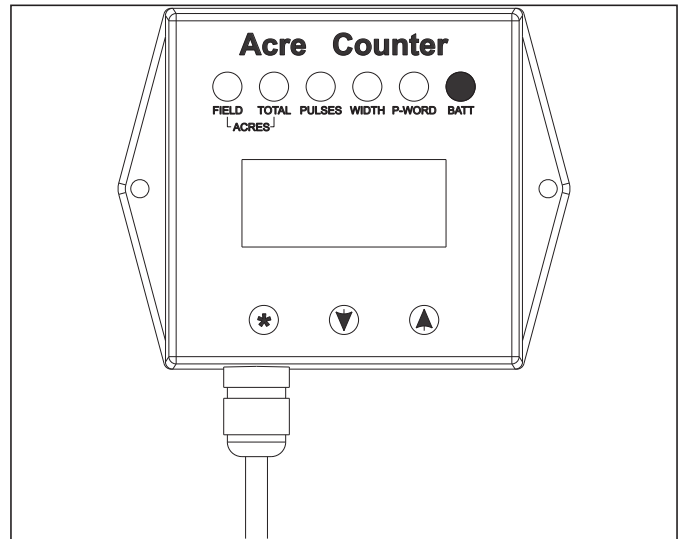

**Figure 4-49: Set Password**

## Battery Replacement

The battery operated acre counter uses 3 AA batteries. The batteries should last between 5 and 10 years. The acre counter will last much longer than that. Eventually, you will have to replace the batteries. The “**BATT**” LED will light when the batteries require replacement *See Figure 4-50*.

1. Remove the acre counter from the implement and undo the 4 screws on the back of the case. This will separate the housing from the rear plate.
2. Replace the batteries with 3 high quality AA alkaline batteries.



**Figure 4-50: Battery Replacement Required**

*This unit is dust and splash resistant, under no circumstances should this unit be submerged in any conductive, corrosive, or flammable liquid.*

# Maintenance and Lubrication

## Wheel Bearing Maintenance – Triple-Lip

Wheel bearing maintenance should be performed at the beginning of every season of use. Check the wheel bearings periodically for excessive end play. If needed, adjust or replace them using the following procedure:

1. Place the frame on blocks or stands sufficient to lift the tire clear of the ground.
2. Remove the tire.
3. Remove the hub cap, cotter pin, slotted nut and washer.
4. Remove the hub. Clean and inspect the bearings and hub cavity. Replace any worn or defective parts.
5. Repack the bearings using a high-quality wheel bearing grease.
6. Slide the triple-lip seal onto the spindle. Do not install the seal into the hub.
7. Slide the inner bearing cone and hub onto the spindle.
8. Install the outer bearing cone, washer and slotted nut.
9. Tighten the slotted nut while rotating the hub until there is a slight resistance to wheel rotation. Then, back the slotted nut off one notch, until the wheel rotates freely without end play.
10. Slide the triple-lip seal to the hub and install the seal in the hub.

*The triple-lip seals should point away from the hub to keep contaminants out and allow grease to pass* See **Figure 5-1**.

1. Install a new cotter pin and replace the hub cap. See **Figure 5-1**.

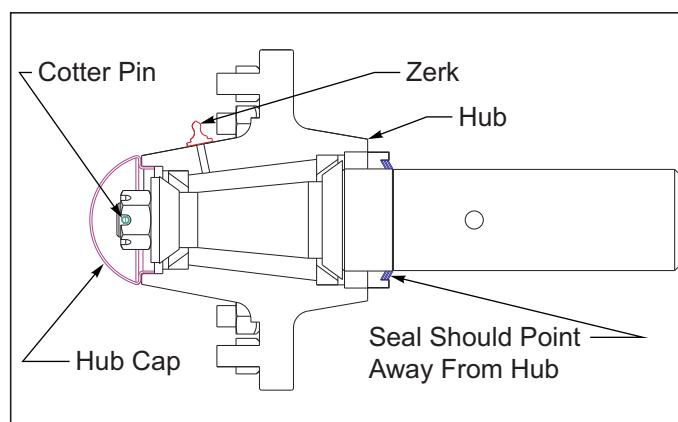

**Figure 5-1: Triple Lip-Seal**

## Hydraulic Maintenance

1. Check the tractor hydraulic fluid level per tractor owner's manual and after any leakage. Check fluid level with the cylinders in the retracted position.
2. If a cylinder or valve leaks, disassemble the parts to determine the cause of the leak. Any time a cylinder is opened up, or whenever any seal replacement is necessary, it is advisable to clean all parts and replace all seals. Seal kits are available from your Landoll dealer.
3. Check all hydraulic hoses weekly. Look for binding or cracking. Replace all worn or defective parts immediately.

### **IMPORTANT**

**Lower the unit to the ground, and relieve hydraulic pressure before attempting to service any hydraulic component.**

4. Transport locks are provided to hold the implement in a raised position. Do not attempt to perform any service work under the implement without first installing the transport locks. Before servicing any hydraulic component, lower the implement to the ground and relieve all system pressure. If a hydraulic component is disconnected, repaired, or replaced, it will be necessary to purge the system of air before operation. ***“Hydraulic Lift System - Pull Hitch” on page 4-9*** on how to purge the hydraulic systems.

## Hose Identification

1. The hydraulic hoses are color coded to help identify and match the attaching hoses on the Grain Drill. An identification decal is placed on the front of the hitch to help identify the hoses ***See Figure 5-2.***
2. For the Grain Drill, hoses will be identified as follows:  
Blue - Lift Wheels  
Black - Auxiliary (Optional Row Markers)

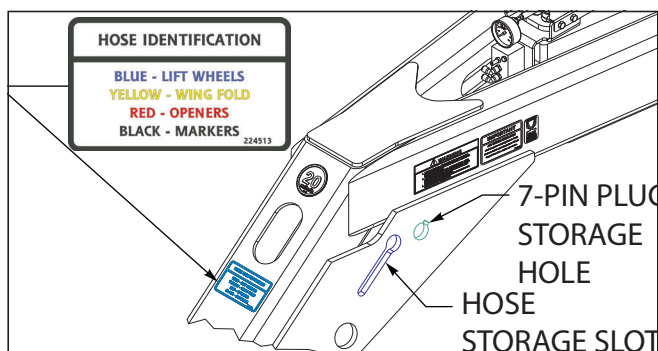

**Figure 5-2: Hose Decal**

## Parking

1. When unhitching the grain drill from the tractor, park the drill on a level area to prevent rolling and shifting. The Grain Drill has negative hitch weight and will need to be lowered to the ground for parking. Any seed left in the drill will increase the negative hitch weight. It is best to park the drill without any seed left in the box.



### **WARNING**

**The Grain Drill has negative tongue weight. Use a properly sized locking style hitch pin for the tractor drawbar and drill hitch. Stand clear of hitch when pinning/unpinning the drill hitch.**

1. To park the drill:
  - a. Fully raise the drill extending the main lift cylinders
  - b. Remove the transport locks from the cylinder shafts and place in the storage location ***See “Storage & Transport Position of Lockouts” on page 4-5.***
  - c. Remove the parking stands from transport position ***See Figure 5-3*** and install the parking stands in Storage position ***See Figure 5-4.*** If storing on soft ground, place board/plate under the stands for a wider footprint.

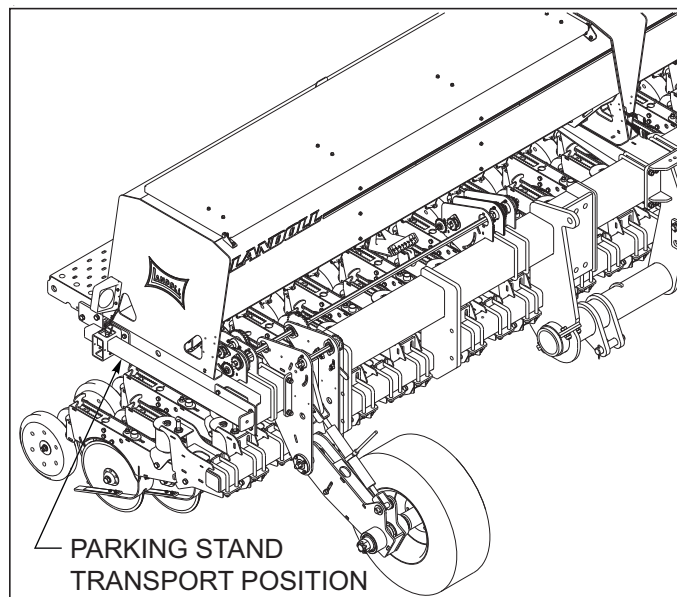

**Figure 5-3: Parking Stand Transport Position**

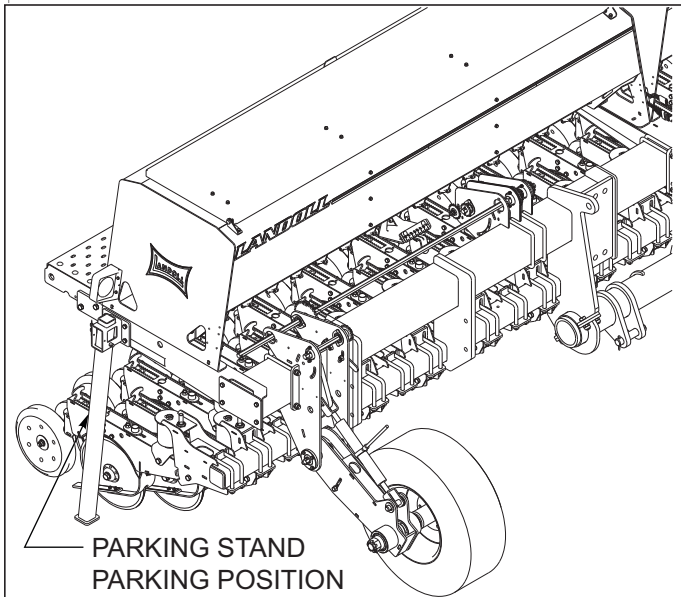

**Figure 5-4: Parking Stand Parking Position**

d. Lower the Grain Drill to the ground.

e. Remove the jack from the storage position *See Figure 5-5* and install the jack in the storage position *See Figure 5-6*. If storing on soft ground, place board/plate under the jack for a wider foot print..

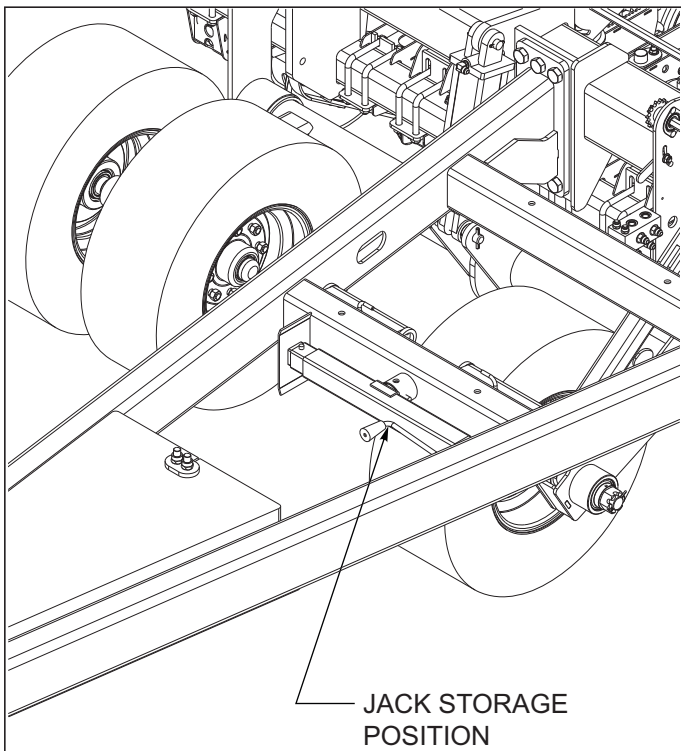

**Figure 5-5: Jack Storage Position**

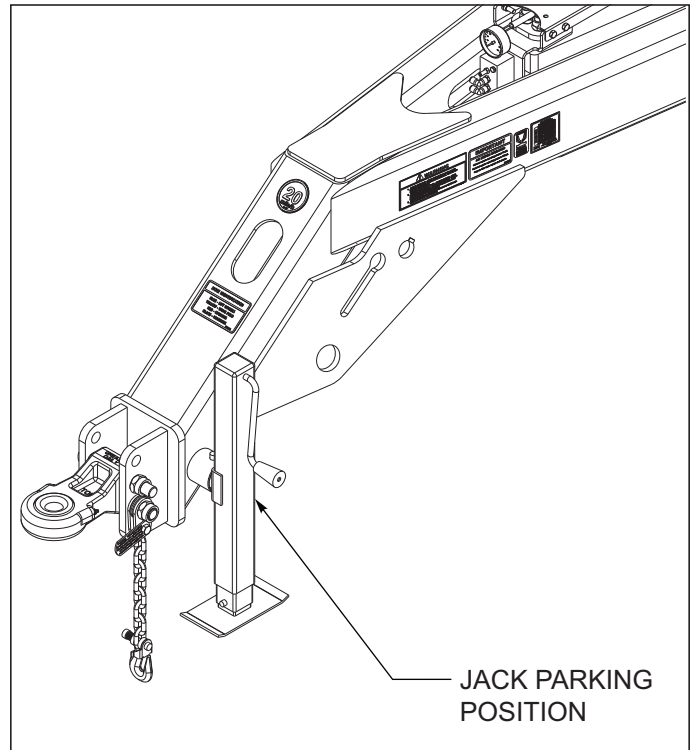

**Figure 5-6: Jack Parking Position**

f. Disconnect the hydraulic hoses and place in the storage slots on the sides of the hitch *See Figure 5-2*.

g. Unplug the seven-pin electrical connector and store in the hole on the either side of the hitch *See Figure 5-2*.

h. Disconnect the safety chain from the tractor. Attach the chain hook close to the chain attaching point to keep the hook off the ground.

i. Carefully remove the hitch pin.

## Lubrication Maintenance

1. **Table 5-1** specifies the lubrication points and intervals on the 5211 Grain Drill. Proper maintenance of your machine will, under normal operating conditions, help to keep it operating at or near its peak performance for an extended period of time. Proper maintenance is also a condition of keeping your warranty in good status **See Figure 5-7**.
2. The drill should be lubricated after initial setup and prior to field operations. When lubricating the Grain Drill, SAE multi-purpose EP grease, or EP grease with 3-5% molybdenum sulfide is recommended. Wipe soil from fittings before greasing. Replace any lost or broken fittings immediately.
3. The Grain Drill is equipped with maintenance-free bearings in the lifts. These areas require no lubrication.

<b>LUBRICATION TABLE</b>			
<b>ITEM</b>	<b>DESCRIPTION</b>	<b>NO. OF LUBE POINTS</b>	<b>INTERVAL (Hours Unless Stated)</b>
1	Coulter Hitch Lift-Lower Rockshaft bearing cap	2	50
2	Coulter Hitch Lift-Upper Rockshaft bearing cap	2	50
3	Coulter Hubs	1 each	50
4	Marker Arm	4	50
5	Marker Hub	2	50

**Table 5-1: Lubrication Table**

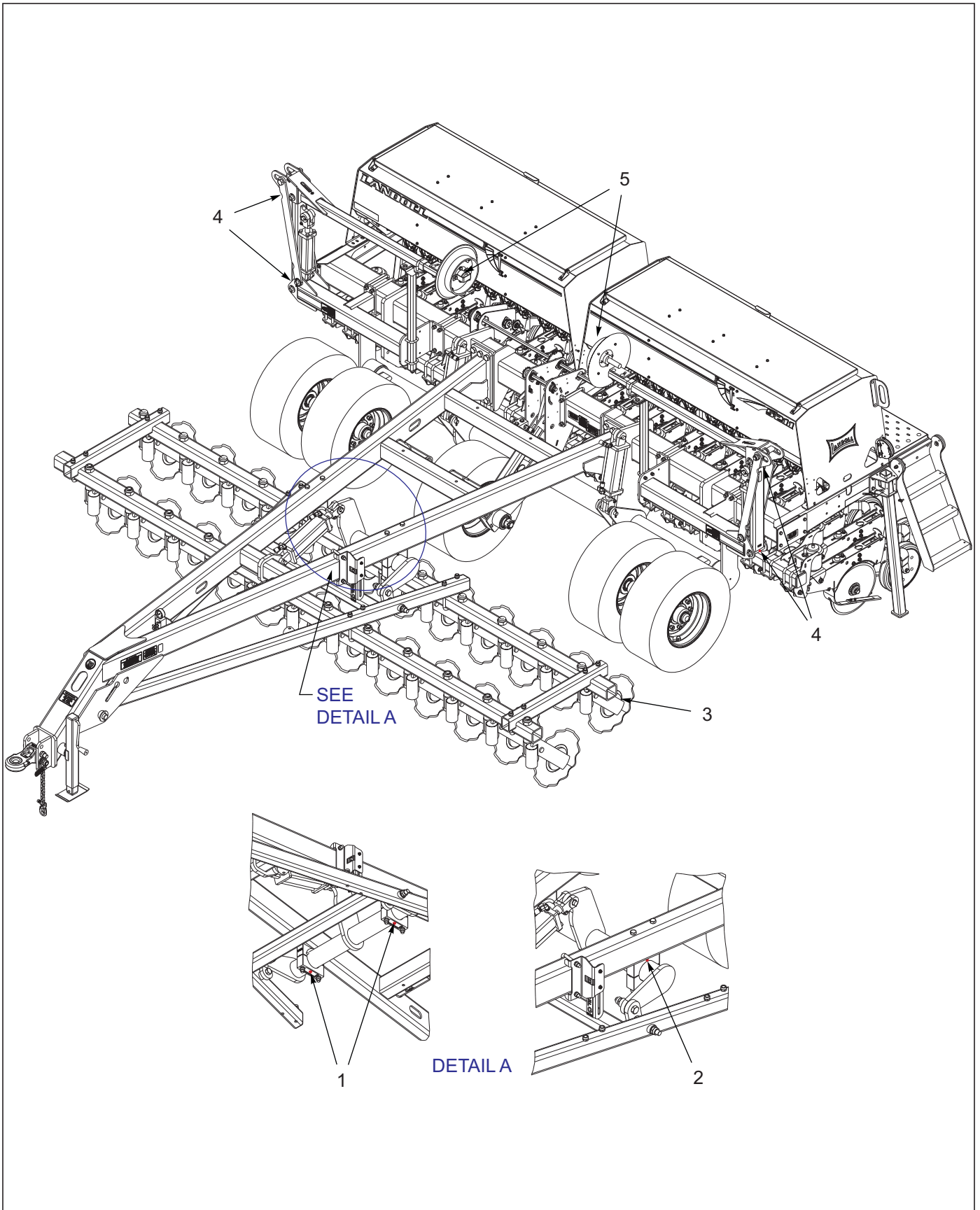

**Figure 5-7: Lubrication Points**

### **Storage**

Preparing the Grain Drill for storage during extended periods of time will not only help protect the drill, but insure that it will be maintained, serviced, and ready for the next planting season.

1. Clean out any remaining seed and fertilizer from the boxes and meters before storage. Thoroughly remove and wash out any dry fertilizer.
2. Wash or blow off any remaining dirt, mud or residue from the drill.
3. Inspect the drill for worn or broken parts. Make repairs and service during the off season to prevent delays.
4. Lubricate the drill at all points **See “Lubrication Maintenance” on page 5-4.**
5. Check opener pinch point for proper adjustment.
6. Clean and repack the wheel bearings.
7. Inspect all nuts and bolts for tightness.
8. Touch up any scratches or chips with spray paint to protect the metal.
9. Check and inflate tires to the proper air pressure.
10. Maintain air system operating pressure on the openers.
11. Lower the drill and store sitting on the ground if possible, place under the openers to protect them from setting in the soil, this will reduce tension on the rubber seed tubes. If the drill is stored in the raised position, disconnect the lower end of the rubber seed tubes.
12. Store the drill inside if possible. If stored outside, cover with a tarp.

# Troubleshooting Guide

The Troubleshooting Guide, shown below, is included to help you quickly locate problems that can happen using your 5211 Grain Drill. Follow all safety precautions stated in the previous sections when making any adjustments to your machine.

<b>PROBLEM</b>	<b>PROBABLE CAUSE</b>	<b>SOLUTION</b>
PLANTING TOO DEEP	Incorrect depth	Adjust press wheel height <i>See “Opener – Press Wheel Adjustment” on page 4-26.</i>
	Excessive down pressure	Reduce air system pressure on row units <i>See “Air System Pressure” on page 4-8.</i>
	Drill not level front to rear, hitch too high	Adjust hitch height <i>See “Leveling the Hitch Clevis” on page 4-6.</i>
PLANTING TOO SHALLOW	Incorrect depth	Adjust press wheel height <i>See “Opener – Press Wheel Adjustment” on page 4-26.</i>
	Insufficient down pressure	Increase air system pressure on row units <i>See “Air System Pressure” on page 4-8.</i>
	Drill not level front to rear, hitch too low	Adjust hitch height <i>See “Leveling the Hitch Clevis” on page 4-6.</i>
	Excessive air pressure	Drill riding on press wheels holding openers out of ground.
UNEVEN SEED DEPTH	Row unit depth not set the same	Adjust press wheel height <i>See “Opener – Press Wheel Adjustment” on page 4-26.</i>
	Drill not level front to rear	Adjust hitch height <i>See “Leveling the Hitch Clevis” on page 4-6.</i>
	Seed shallow in tire tracks	Adjust press wheel height and increase down pressure ( <i>See “Air System Pressure” on page 4-8 and “Opener – Press Wheel Adjustment” on page 4-26.</i> )
	Excessive field speed	Reduce field speed.
	Plugged seed tube	Clean seed tube.
	Mud build up between opener blades	Adjust scraper <i>See “” on page 4-26.</i> Adjust blade pinch point <i>See “Spring Opener” on page 4-29.</i>
	SECTIONS PLANTING AT DIFFERENT RATES	Seed rate adjustment not the same on all sections
	Drive types (sprocket ratio) not the same on all sections	Change to same drive type on all sections.
	Seed meter out of adjustment	Reset seed meters.
	Opener seed tube plugged	Clean out seed tube.
	Broken seed meter	Allows excessive seeding - repair seed meter.
	Seedbox plugged/Seed bridged	Clean/Agitate seed

## TABLE OF CONTENTS

PROBLEM	PROBABLE CAUSE	SOLUTION
UNEVEN SEED SPACING	Excessive field speed	Reduce field speed.
	Unclean seed	Use clean seed
	Build up of seed treatment in seed cup	Clean out seed meters
	Seed tubes sagging	Replace seed tube
	Drive type (sprocket ratio) too slow	Use faster drive type and readjust seed meter opening.
	Plugged opener seed tube	Clean out bottom of seed tube.
OPENER DISCS NOT TURNING FREELY	Opener plugged with mud/dirt	Clean opener.
	Scraper set too tight	Adjust scraper <a href="#">See "" on page 4-26.</a>
	Soil control strip set too tight against opener blades	Adjust soil strip
	Soil strip plugged with residue	Adjust soil strip closer to blade, move metal backing strip away from edge of soil strip <a href="#">See "Opener Soil Strip Adjustment" on page 4-28.</a>
PRESS WHEELS NOT COMPACTING THE SOIL AS DESIRED	Opener down pressure set too low	Increase air system pressure on row units <a href="#">See "Air System Pressure" on page 4-8.</a>
	Incorrect press wheel depth adjustment	Reset press wheel depth adjustment <a href="#">See "Opener – Press Wheel Adjustment" on page 4-26.</a>
PRESS WHEEL OR OPENERS PLUGGING	Backed up with openers in the ground	Clean out opener and press wheels and check for damage.
	Scraper worn or not adjusted correctly	Replace or adjust scraper
	Opener blades worn, pinch point too wide	Reset pinch point, replace worn out blades.
	Planting conditions too wet	Wait until drier weather
	Opener bearing failure	Replace opener bearings
AIR SPRING LEAKING AIR	Air spring not set all the way forward or backward in adjustment slots	Replace and reposition air spring
	Operating with too low air pressure	Minimum air system pressure is 15 psi <a href="#">See "Air System Pressure" on page 4-8.</a>
	Broken air spring stud	Replace air spring, maximum stud torque 30 ft-lbs.
AIR SYSTEM LEAK - FAST	Broken or pinched air line	Check hitch and wing hinge areas for broken or pinched air line.
	Broken fitting	Repair fitting
	Air line disconnected	Reconnect air line.
	Air spring has hole	Replace air spring.
AIR SYSTEM LEAK - SLOW	Air leaking thru air compressor filter	Check valve leaking. Replace check valve
	Air line/fitting connection leaking	Air lines ends must be cut square, and not scratched. Recut air line end if necessary. Push-in fitting lock ring when inserting or removing air lines.
	Air relief valve leaking	Clean or replace air relief valve.
	Air manifold leaking	Check front and rear manifolds for leaks.
	Air valve leaking	Tighten/replace Schrader air valve on front manifold.
	End caps on center section opener bar (air reservoir) leaking.	Relief system air pressure, and repair leaking weld.
	<b>NOTE</b> <i>Use a spray bottle with a soapy water solution to check for the following leaks.</i>	

## Document Control Revision Log:

Date	Form #	Improvement(s): Description and Comments
10/04/2013	F-725-0713	Initial Release
01/10/2022	F-725-0122	Updated whole manual, added rebounder, spring openers
04/19/2022	F-725-2404	Updated ISO logo, Model Specs, added wrench adjust wrenches, scale mount kit, dual drive wheel 3 pint hitch option, 5211-10' & 20' 6"spacing option
12/01/2025	F-725-2512	Added 6" spacing rate charts.
04/22/2026	F-725-2604	Added 252886 sprocket assembly to small seed drive in Operator section.



**intertek**

Equipment from Landoll Company, LLC is built to exacting standards ensured by ISO 9001:2015 registration at all Landoll manufacturing facilities.

# **Model 5211**

## **Grain Drill**

### **Operator's Manual**

### **Re-order Part Number F-725**

**LANDOLL COMPANY, LLC**

1900 North Street

Marysville, Kansas 66508

(785) 562-5381

**800-428-5655 ~ WWW.LANDOLL.COM**



Copyright 2026. Landoll Company, LLC

“All rights reserved, including the right to reproduce this material or portions thereof in any form.”

