

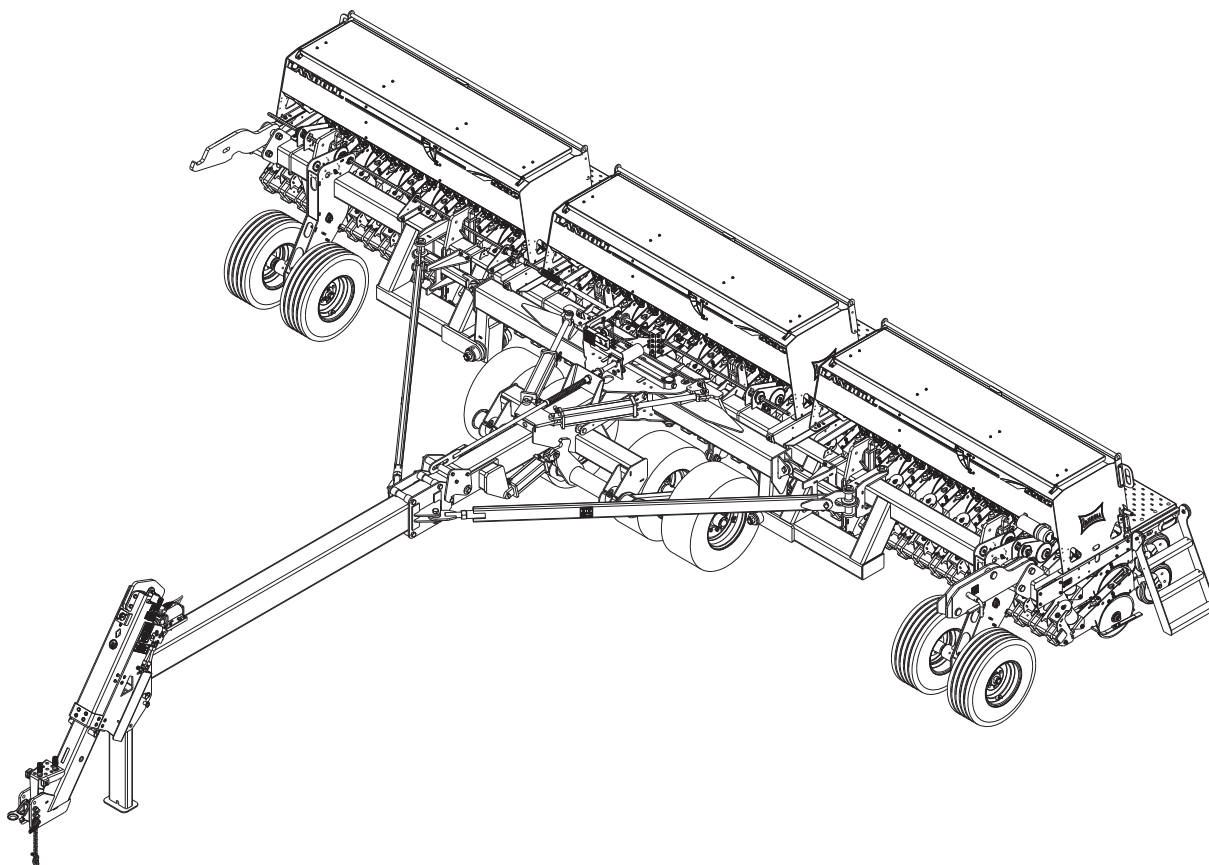

Model 5532
Grain Drill
Operator's Manual



LANDOLL COMPANY, LLC

1900 North Street

Marysville, Kansas 66508

(785) 562-5381

800-428-5655 ~ WWW.LANDOLL.COM

Instructions for Ordering Parts

**** Repair parts must be ordered through an Authorized Dealer ****

DEALER INSTRUCTIONS FOR ORDERING PARTS FROM LANDOLL PARTS DISTRIBUTION CENTER

Phone #: 800-423-4320 or 785-562-5381

Fax #: 888-527-3909

Order online: dealer.landoll.com

SERIAL NUMBER PLATE

The Serial Number Plate, which lists the model number and serial number, is located on the front of the hitch

See Figure 1-1.

SERIAL NUMBER NOMENCLATURE

The following information will help decode the 5532 GD serial number

55H2600100 = xxmysssss

The 5532 GD series QR code decal, may be scanned to link to the most current manuals, located on the front of the frame *See Figure 1-1.*

xx	= model series (i.e. 55 for Grain Drill, Fold)
m	= month of manufacture (ex. "H" means October. The letter I is not used.)
yy	= year manufactured (ex. "26" means 2026)
sssss	= Sequential number used to track warranty and service information.

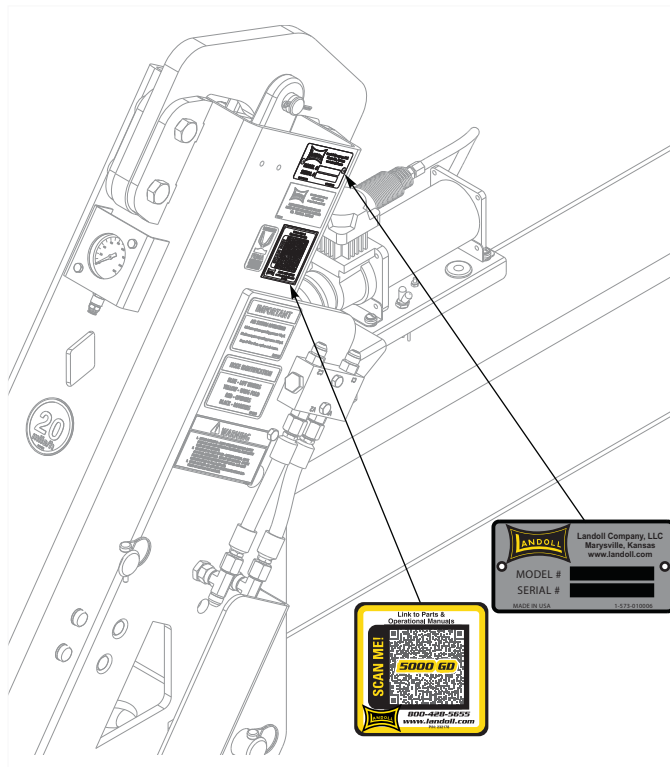

Figure 1-1: Serial Number Plate and QR Code Decal Location

Manuals for 5532 Grain Drill

Manual Number	Manual Type
F-1193	Operator's Manual
F-1194	Parts Manual



DANGER

DO NOT operate or perform any maintenance tasks on this equipment until you have completed the following:

- 1. Receive proper training to operate this equipment safely.**
- 2. Read and understand the operator's manual.**
- 3. Be thoroughly trained on inspection and repair procedures.**

Failure to comply with this warning may result in serious injury or possibly death.

Table of Contents

1 Introduction and Safety Information

Understanding Safety Statements	1-2
Transporting Safety	1-3
Attaching, Detaching, and Storage	1-3
Maintenance Safety	1-3
High Pressure Fluid Safety	1-3
Protective Equipment	1-3
Chemical Safety	1-3
Prepare for Emergencies	1-4
Tire Safety	1-4
Safety Chain	1-4
Safety Decals and Reflectors	1-5

2 Specifications

Introduction	2-1
Owner Assistance	2-1
Warranty Registration	2-1
General Torque Specifications	2-4
Hydraulic Fitting Torque Specifications	2-5
Model Specifications	2-6
Drive Placement	2-8

3 Assembly Instructions

Assembly Safety	3-1
Press Wheel Assembly	3-2
Small Seed Attachment Installation (Option)	3-4
Agitator Assembly (Option)	3-8
5532 Hydraulic Marker Installation (Optional)	3-12

4 Operation

5532 Operation Checklist	4-2
Initial Checklist	4-2
Field Checklist	4-2
Field Operation	4-3
Planting Completion	4-3
Tractor Preparation	4-4
Grain Drill Preparation	4-4
Attaching Grain Drill To The Tractor	4-4
Hitch Cylinder and Wing Lock	4-5
Folding/Unfolding the Grain Drill	4-6
Leveling the Hitch Clevis	4-6
Leveling the Hitch	4-7
Transporting the Grain Drill	4-7
Compressor Operation	4-9
Opener Air Pressure	4-10

Maintenance	4-11
Openers – Hydraulic Operation	4-11
Opener Bar Cylinder Lockout	4-12
Hydraulic Lift System	4-12
Loup Drill Monitor Operation	4-13
Seed Meter Gate Adjustment	4-14
Seed Rate Adjustment	4-15
Meter/Seed Rate Handle Adjustment	4-16
Seed Rate Calibration	4-18
Dry Fertilizer Combination Box	4-18
Fertilizer Box – Clean Out	4-20
Fertilizer – Rate Adjustment	4-21
Fertilizer – Rate Calibration	4-22
Small Seed Rate Adjustment	4-22
Seed Rate Calibration	4-24
Small Seed Meter Assembly/Adjustment	4-26
Small Seed Disconnect	4-27
Air Spring Adjustment	4-28
Opener Blade Adjustment	4-29
Opener Blade Wear	4-29
Opener – Press Wheel Adjustment	4-30
Opener Scraper Adjustment	4-31
Opener Soil Strip Adjustment	4-32
Drive Shaft – Coupler Alignment	4-33
Walkboard	4-34
Ladder Use and Transport Requirements	4-35
Hydraulic Row Markers (Option)	4-36
Hydraulic Row Marker Disc Adjustment (Option)	4-37
5532 Point Row Clutch (Option)	4-38

5 Maintenance and Lubrication

Wheel Bearing Maintenance – Non Triple-Lip	5-1
Hydraulic Maintenance	5-1
Hose Identification	5-2
Parking	5-2
Lubrication Maintenance	5-3
Storage	5-6

6 Troubleshooting Guide

Introduction and Safety Information

The Landoll Model 5532 Grain Drill is a quality product designed to give years of trouble free performance. By following each section of this manual, your system will perform as designed for you and your operation.

- CHAPTER 1** Gives basic instructions on the use of this manual and understanding the safety statements.
- CHAPTER 2** Gives product specifications for the equipment. These specifications supply lengths and measures for your equipment. A Standard Bolt Torque Table is provided to give guidelines for bolt torques to be used when servicing this product.
- CHAPTER 3** Contains assembly instructions for your equipment. When these procedures are correctly followed, your equipment should provide you years of trouble-free operation and service.
- CHAPTER 4** Instructs how to operate your equipment before using it, and describes adjustments needed.
- CHAPTER 5** Instructs how to operate your equipment before using it, and describes adjustments needed. Gives practical advice for the care and maintenance of your Landoll equipment. Drawings in this section locate adjustment points on the equipment.

IF YOU HAVE ANY QUESTIONS CONTACT:

**LANDOLL COMPANY, LLC
1900 NORTH STREET
MARYSVILLE, KANSAS 66508**

PHONE # (785) 562-5381 or (800) 428-5655

OR

FAX # (888) 527-3909

- CHAPTER 6** Is a troubleshooting guide to aid in diagnosing and solving problems with the equipment.
- PARTS LIST** Is a separate manual showing the various assemblies, subassemblies, and systems. Refer to that manual when ordering Landoll replacement parts. Order parts from your Landoll dealer.
- WARRANTY** To be eligible for Warranty, registration must be on file at Landoll Company, LLC. It is the responsibility of the dealer to register the machine within 10 days of purchase or lease on the Dealer Portal. Check with the dealer to verify the machine has been registered.
NOTE: IMPROPER ASSEMBLY, MODIFICATION, OR MAINTENANCE OF YOUR LANDOLL MACHINE CAN VOID YOUR WARRANTY.
- COMMENTS** Address comments or questions regarding this publication to:

**LANDOLL COMPANY, LLC
1900 NORTH STREET
MARYSVILLE, KANSAS 66508
ATTENTION: PUBLICATIONS - DEPT. 55**

Understanding Safety Statements

You will find various types of safety information on the following pages and on the machine signs (decals) attached to the machine. This section explains their meaning.



The Safety Alert Symbol means ATTENTION! YOUR SAFETY IS INVOLVED!

NOTE

Means that failure to follow these instructions could cause damage to the equipment or cause it to operate improperly.

NOTICE

Special notice - read and thoroughly understand.



CAUTION

Caution means serious equipment or other property damage can occur if instructions on this label are not properly followed.



WARNING

Warning means serious injury or death can occur if safety measures or instructions on this label are not properly followed.



DANGER

Danger means a life-threatening situation exists. Death can occur if safety measures or instructions on this label are not properly followed.

NOTE

Make sure you read and understand the information contained in this manual and on the machine signs (decals) before you attempt to operate or maintain this machine.

The safety statements contained in this manual relate to the operation of the 5532 Grain Drill.

1. Examine safety decals and be sure you have the correct safety decals for the implement.
2. Keep these signs clean so they can be observed readily. It is important to keep these decals cleaned more frequently than the implement. Wash with soap and water or a cleaning solution as required.
3. Replace decals that become damaged or lost. Also, be sure that any new implement components installed during repair include decals which are assigned to them by the manufacturer.
4. When applying decals to the implement, be sure to clean the surface to remove any dirt or residue. Where possible, sign placement should protect the sign from abrasion, damage, or obstruction from mud, dirt, oil etc.

Transporting Safety

IMPORTANT

It is the responsibility of the owner/operator to comply with all state and local laws.

1. Do not tow an implement that, when fully loaded, weighs more than 1.5 times the weight of the towing vehicle.



DANGER

- Do not allow anyone to ride on the tractor or implement. Riders could be struck by foreign objects or thrown from the implement.
- Never allow children to operate equipment.
- Keep bystanders away from implement during operation.

2. Carry reflectors or flags to mark the tractor and implement in case of breakdown on the road.
3. Do not transport at speeds over 20 MPH under good conditions. Never travel at a speed which does not allow adequate control of steering and stopping. Reduce speed if towed load is not equipped with brakes.
4. Avoid sudden stops or turns because the weight of the implement may cause the operator to lose control of the tractor.
5. Use caution when towing behind articulated steering tractors; fast or sharp turns may cause the implement to shift sideways.
6. Keep clear of overhead power lines and other obstructions when transporting. Know the transport height and width of your implement.

Attaching, Detaching, and Storage

1. Do not stand between the tractor and implement when attaching or detaching implement unless both are not moving.
2. Chock the tires of the implement so it will not roll when unhitched from the tractor.
3. Store in an area where children normally do not play.

Maintenance Safety

1. Understand the procedure before doing the work. Use proper tools and equipment.
2. Make sure all moving parts have stopped.
3. Do not make adjustments or lubricate implement while it is in motion.
4. Block the implement so it will not roll when working on or under it to prevent injury.

High Pressure Fluid Safety

1. Escaping fluid under pressure can be nearly invisible and have enough force to penetrate the skin causing serious injury. Use a piece of cardboard, rather than hands, to search for suspected leaks.
2. Any fluid injected into the skin must be surgically removed within a few hours or gangrene may result.
3. Avoid the hazard by relieving pressure before disconnecting hydraulic lines.

Protective Equipment

1. Wear protective clothing and equipment.
2. Wear clothing and equipment appropriate for the job. Avoid loose fitting clothing.



3. Because prolonged exposure to loud noise can cause hearing impairment or hearing loss, wear suitable hearing protection, such as earmuffs or earplugs.

Chemical Safety

1. Agricultural chemicals can be dangerous. Improper use can seriously injure persons, animals, plants, soil and property.
2. Read chemical manufacturer's instructions and store or dispose of unused chemicals as specified.
3. Handle chemicals with care and avoid inhaling smoke from any type of chemical fire.
4. Store or dispose of unused chemicals as specified by the chemical manufacturer.

Prepare for Emergencies

1. Keep a First Aid Kit and Fire Extinguisher handy.
2. Keep emergency numbers for doctor, ambulance, hospital, and fire department near the phone.

Tire Safety

1. Tire changing can be dangerous and should be performed by trained personnel using correct tools and equipment.
2. When inflating tires, use a clip-on chuck and extension hose long enough to allow you to stand to one side, not in front of or over the tire assembly. Use a safety cage if available.
3. When removing and installing wheels use wheel-handling equipment adequate for the weight involved.

Safety Chain

1. Use a chain with a strength rating equal to or greater than the gross weight of towed machinery, which is 10,100 pounds minimum in accordance with ASAE S338.2 specifications. If two or more implements are pulled in tandem, a larger chain may be required. Chain capacity must be greater than the TOTAL weight of all towed implements.
2. A second chain should be used between each implement.
3. Attach the chain to the tractor drawbar support or specified anchor location. Allow only enough slack in the chain to permit turning. The distance from hitch pin to attachment point or intermediate support point should not exceed 9 inches.
4. Replace the chain if any links or end fittings are broken, stretched or damaged.
5. Do not use a safety chain for towing.

Safety Decals and Reflectors

The 5532 Grain Drill is equipped with all safety signs installed for safe operation.

For you safety:

- Carefully read and follow safety sign directions.
- Keep the safety signs clean and visible.
- Replace damaged, missing, or illegible safety signs.
- Be sure any new equipment or repair parts include safety signs. New safety signs may be ordered from

your Landoll dealer. Refer to this section for parts and proper safety sign placement.

To Install new safety signs:

1. Remove the old damaged safety sign if still present.
2. Clean placement area to remove any dirt or grease.
3. Remove backing from new safety sign.
4. Apply the safety sign starting from one end pressing firmly and working across the safety sign being careful not to create any air bubbles.

P/N 8-573-010084

Danger: Before Operating



Front of hitch, bottom, left side.

QTY. 1

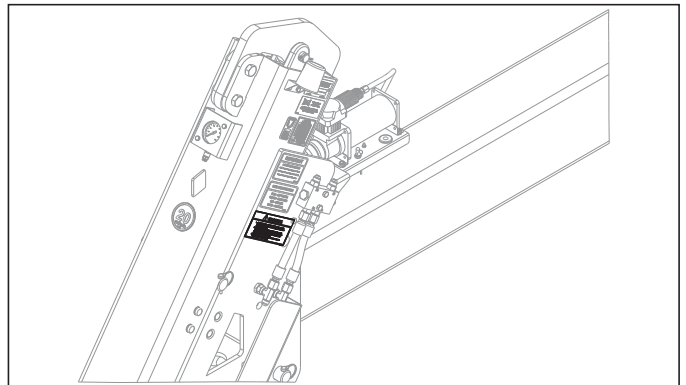

P/N 224513

Hose Identification



Front of hitch, middle, left side.

QTY. 1

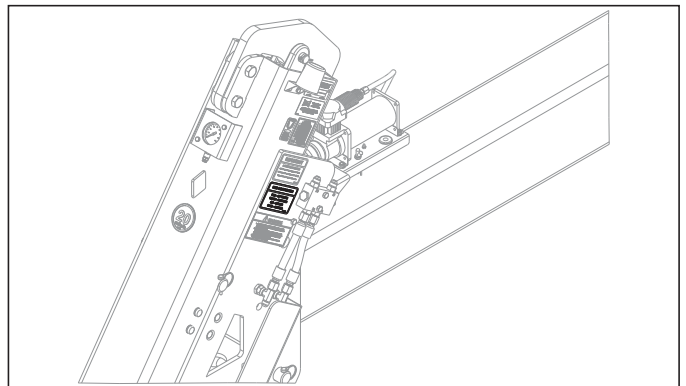

P/N 211045

Important: Air System Operation

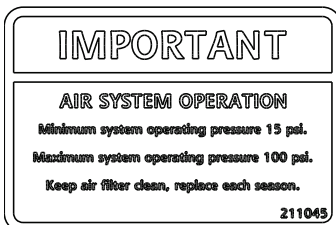

Front of hitch, top, left side.

QTY. 1

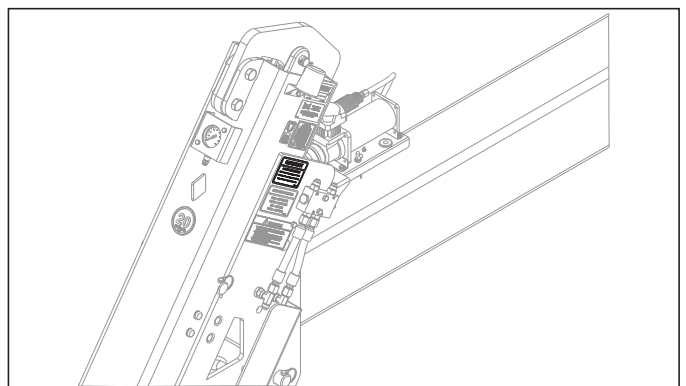

P/N 144193
SIS 20 MPH



Front of hitch.
QTY. 1

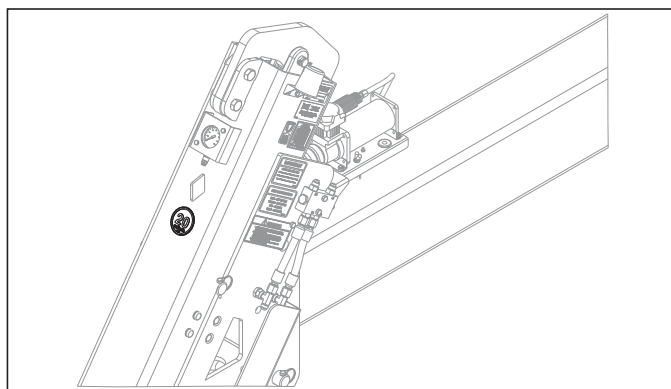

P/N 211082
Important: Opener Air Pressure

IMPORTANT

OPENER AIR PRESSURE

READ OPERATORS MANUAL FOR PROPER OPERATION

1. Raise openers when adjusting air pressure.
2. To increase pressure - adjust regulator to higher pressure setting.
3. To lower pressure - adjust regulator to lower pressure setting, open drain until pressure gauge falls to regulator setting.
4. Large adjustments may take several minutes to equalize air system.
5. Actual opener (planting) pressure will always be higher than regulator setting.

211082

Front cover manifold assembly.
QTY. 1

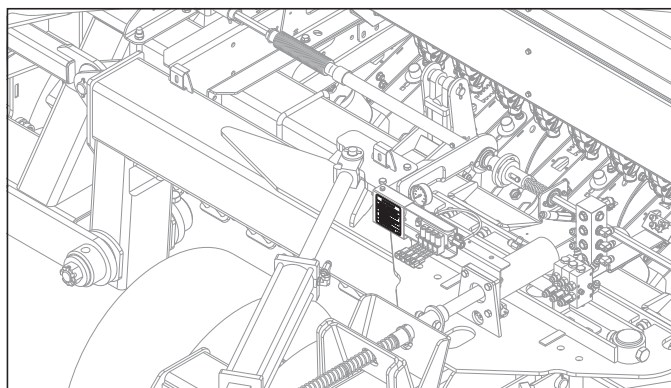

P/N 255765
Warning: Lock/Unlock

WARNING

To prevent serious injury or machine damage:
 Install lock pin before transporting or servicing raised equipment.
LOCK - Push In
UNLOCK - Pull Out

255765

Wing lock latch left side.
QTY. 1

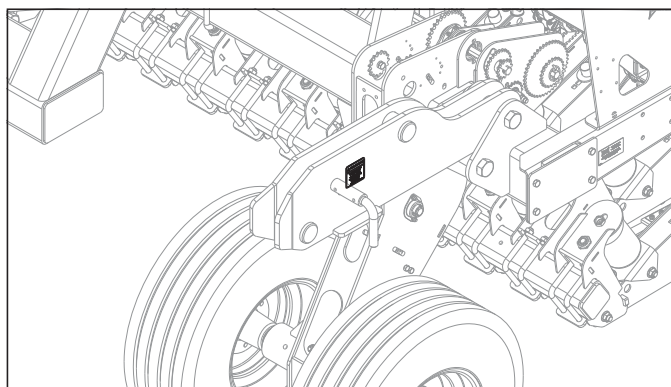

P/N 2-573-010335
Danger: Pinching

DANGER

To prevent serious injury or death from pinching:
 • Keep all persons and objects clear while any part of this machine is in motion.

2-573-010335

Tongue brace, both sides.
QTY. 2

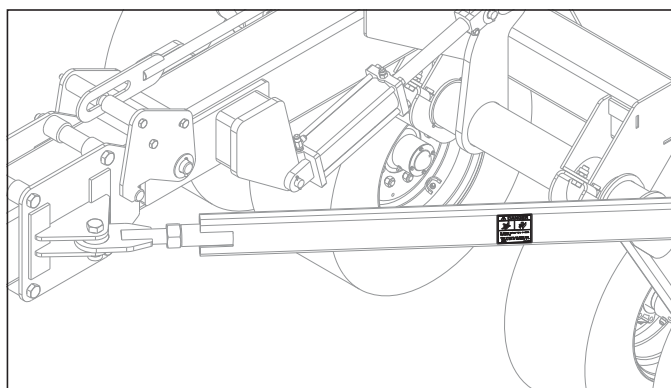

TABLE OF CONTENTS

P/N 528934

Yellow Reflector



Center frame, both sides.

QTY. 2

Walkboard wing, back, both sides.

QTY. 2

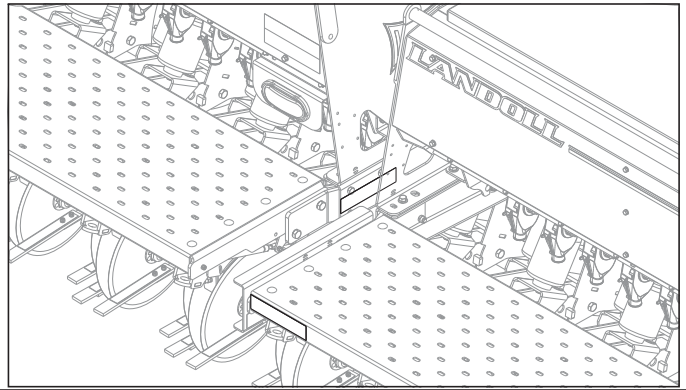

P/N 528934

Yellow Reflector



Walk board wing, outer. Walkboard wing, outer& front, both sides.

QTY.4

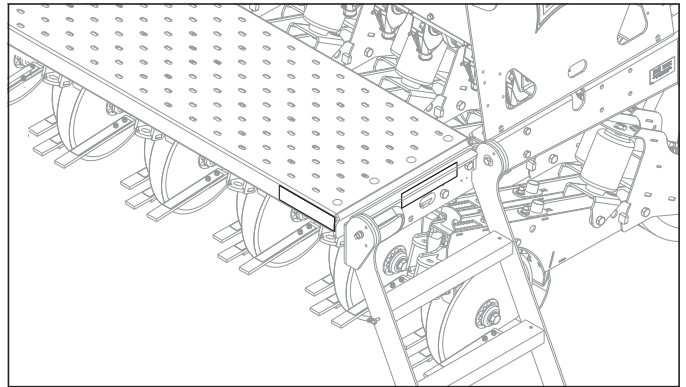

P/N 528933

Red Reflector



Center box, rear, bottom, both sides.

QTY. 2

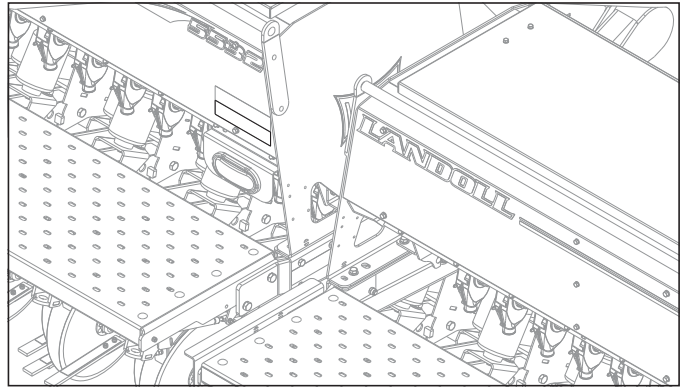

P/N 528933

Red Reflector



Light bracket, bottom, both sides.

QTY. 2

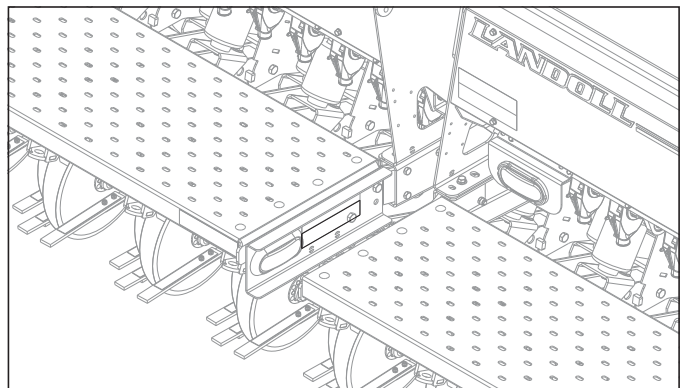

P/N 528938

Orange Reflector



Center box, rear, top, both sides.

QTY. 2

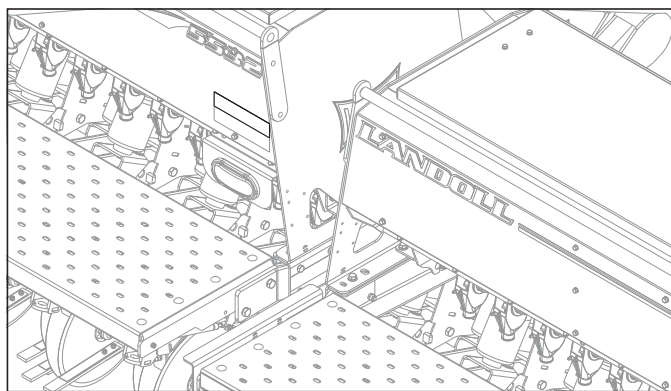

P/N 528938

Orange Reflector



Light bracket, top, rear, both sides.

QTY. 2

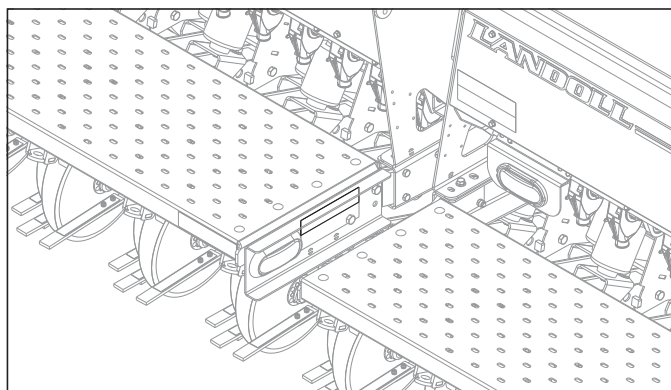

P/N 224589

SIS 20 mile/h (Center Seed Box)



Center seed box, rear.

QTY. 1

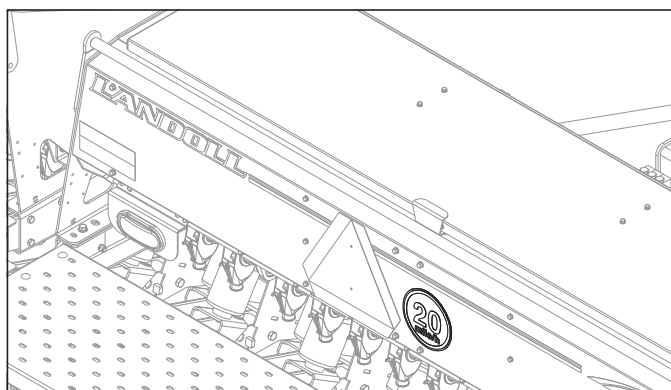

P/N 224589

SIS 20 mile/h (Center Small Seed Box)



Center small seed box, rear.

QTY. 1

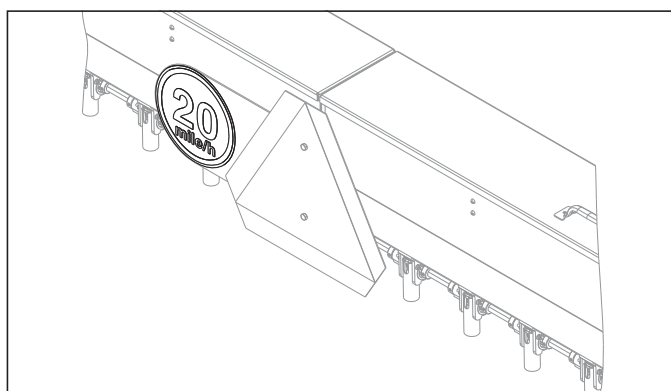

P/N 70260977

SMV Emblem

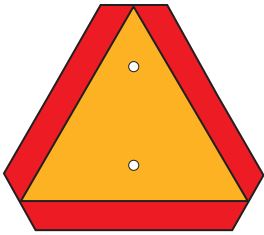

Center seed box, rear.

QTY. 1

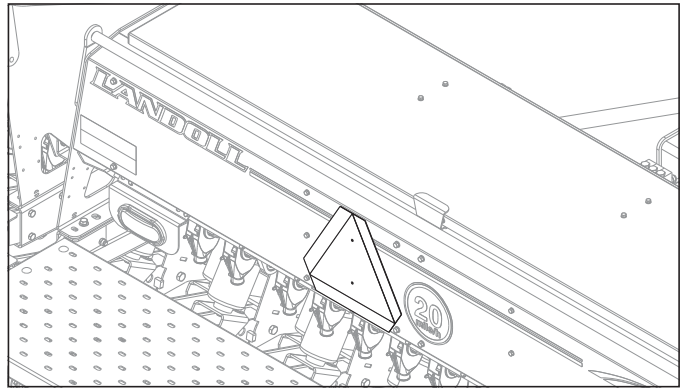

P/N 70260977

SMV Emblem

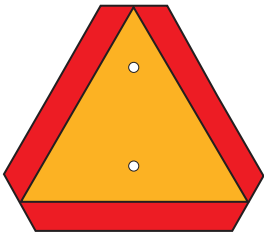

Center small seed box, rear.

QTY. 1

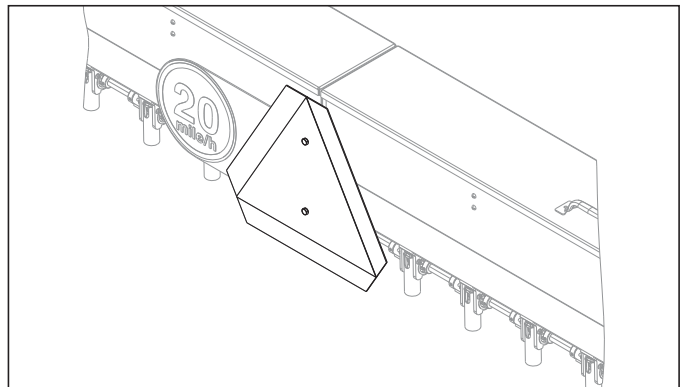

P/N 141597

Danger: Electrocutation Hazard

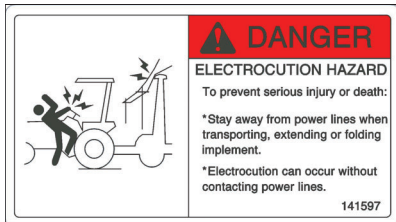

Marker mount, front side, both sides.

QTY. 2

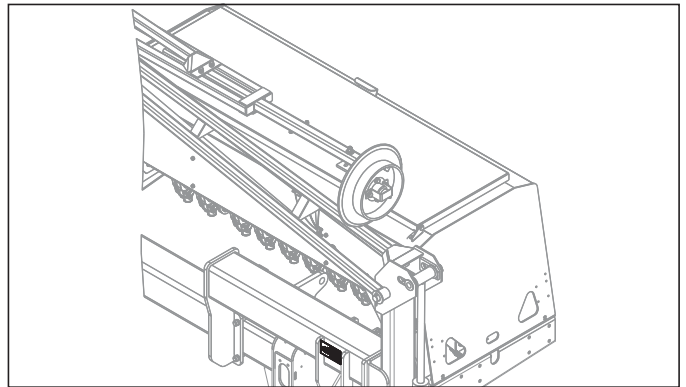

P/N 255798

Store/Lock RT



Opener bar plate, right side.

QTY. 5

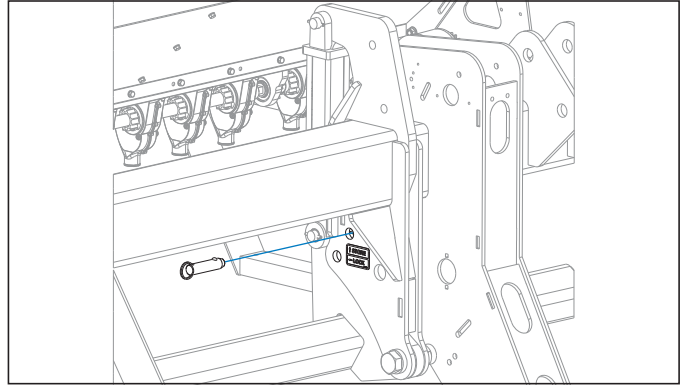

P/N 255799

Store/Lock LT



Opener bar plate, center, left side.

QTY. 1

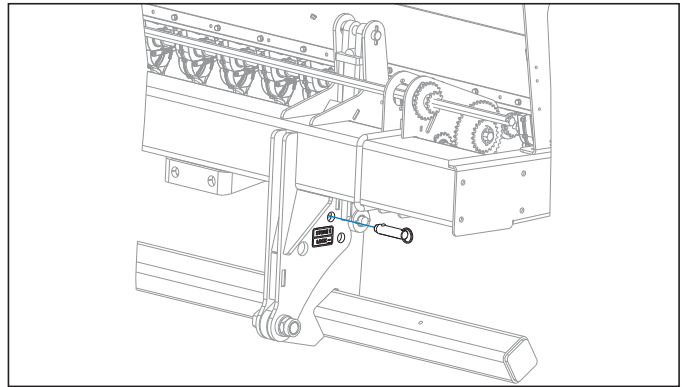

Specifications

Introduction

This manual is compiled as a guide for owners and operators of the 5532 Grain Drill. Read it carefully so as to be able to follow the suggestions made. Please take time to understand the proper maintenance schedule and SAFE operation of your equipment.

In the event that a new and inexperienced operator is placed in charge of running the equipment, they should read and understand, that part of the manual for proper maintenance and SAFE operation, and to be trained in regard by an experienced operator.

Owner Assistance

If customer service or repairs are needed, contact your Landoll dealer. They have trained personnel, parts and service equipment specially designed for Landoll products. Your machine's parts should only be replaced with Landoll parts. Have the Serial Number and complete Model Number available when ordering parts from your Landoll dealer. *See Figure 2-1*



Figure 2-1: Serial Number Plate

Warranty Registration

To be eligible for Warranty, registration must be on file at Landoll Company, LLC. It is the responsibility of the dealer to register the machine within 10 days of purchase or lease on the Dealer Portal. Check with the dealer to verify the machine has been registered.

Take time to read and understand the Warranty for this product, *See Page 2-2* and *See Page 2-3*.

Landoll reserves the right to make changes and/or add improvements to its products at any time without obligation to previously manufactured equipment.

Please take time to complete the following information for your personal reference, should you need to contact your Dealer with questions or parts needs.

MODEL _____

SERIAL # _____

DATE OF PURCHASE _____

DEALER NAME _____

We at Landoll wish to thank you for purchasing our product. We have spent considerable time and effort to research, design, test and develop this machine and are confident it will serve you in the use for which it was designed.



LANDOLL TILLAGE PRODUCT THREE YEAR LIMITED WARRANTY

Landoll Company, LLC warrants each new serial numbered Whole Good Tillage product, when properly assembled, adjusted, serviced, and normally operated, to be free from defects in materials and workmanship for a period of three (3) years, unless otherwise noted, from the date of delivery. Date of delivery shall be the date the Dealer places the product in the possession of the original retail purchaser, and must be confirmed by the Dealer submitting a properly completed Landoll Company, LLC Warranty Registration Form to the Landoll Company, LLC Warranty Department. Warranty starts the day the product is rented or leased. This limited warranty shall be transferable until the expiration date.

Landoll Company, LLC shall repair, or at its option, replace any part(s) of the product determined, by Landoll Company, LLC, to be defective. Landoll Company, LLC may request the return of part(s), freight prepaid via a carrier approved by the Landoll Warranty Staff, to Landoll Company, LLC for further evaluation. If the part is determined to be defective, Landoll Company, LLC will refund the freight charges incurred in returning the defective part(s).

This limited warranty requires pre-authorization by the Landoll Company, LLC Warranty Staff of any warranty related utilization of components or labor, and is subject to specific exclusions and does not apply to any product which has been: 1) subjected to or operated in a manner which, at any time, have exceeded the product design limits; 2) repaired or altered outside our factory in any way so as, in the judgment of Landoll Company, LLC, to affect its stability or reliability; 3) subject to misuse, negligence, accident, or has been operated in a manner expressly prohibited in the instructions; or not operated in accordance with practices approved by Landoll Company, LLC. Operating the product in soils containing rocks, stumps or obstructions may void the warranty in its entirety. Excessive acres, consistent with non-seasonal very large farming operations, and, non-agricultural activities, may further limit the terms of this warranty. The sole obligation of Landoll Company, LLC under this warranty shall be limited to repairing or replacing, at its option, part(s) which shall be identified to Landoll Company, LLC by way of a pre-authorized Landoll Company, LLC Warranty Claim Form. Warranty, expressed or implied, will be denied on any product not properly registered with the Landoll Company, LLC Warranty Department within ten (10) days of the first retail sale. As stated above, Landoll Company, LLC Warranty Staff will identify components listed on a Warranty Claim required to be returned for further analysis. All parts returned to Landoll Company, LLC must be shipped with a Return Materials Authorization (RMA) provided by the Landoll Company, LLC Warranty Staff. Defective components must be returned by the purchaser to Landoll Company, LLC with transportation and freight charges prepaid within thirty (30) days after receipt of the RMA. The examination conducted by Landoll Company, LLC of returned parts shall disclose to its satisfaction the extent the component may be defective.

All parts and labor warranty MUST be pre-authorized by Landoll Company, LLC Warranty Staff. Failure to do so may result in no warranty payment of any kind. Labor will be reimbursed in accordance with published shop rates pre-approved by the Landoll Company, LLC Warranty Staff. Time authorized for specific work will be limited, where appropriate, to the hours listed in the Landoll Company, LLC authorized Labor Rate Guide.

...continued on following page.

Figure 2-2: Landoll Tillage Product Warranty (1 of 2)

LANDOLL TILLAGE PRODUCT THREE YEAR LIMITED WARRANTY

...continued from previous page.

USER'S OBLIGATION:

1. Read the Operator's Manual.
2. Understand the safe and correct operating procedures pertaining to the operation of the product.
3. Lubricate and maintain the product according to the maintenance schedule in the Operator's Manual.
4. Inspect machine and have parts repaired or replaced when continued use of the product would cause damage or excessive wear to other parts.
5. Contact the Landoll Company, LLC Dealer for repair or replacement of defective parts. Mileage incurred by the Landoll Company, LLC Dealer is the customer's responsibility.

This 3-Year Limited Warranty SHALL NOT APPLY TO: (See Warranty Procedure Manual for details.)

1. Ground Engaging Tools.
2. Vendor Warranty Only Parts.

WARRANTY LABOR:

1. Considered during the first year of warranty only.
2. During the second and third year:
 - Warranty labor is not covered. Customer is responsible for removing, replacing and returning the defective part(s) to the Landoll Dealer

THIS WARRANTY IS EXPRESSIVELY IN LIEU OF ALL OTHER WARRANTIES OF MATERIAL, WORKMANSHIP DESIGN, APPLICATION OR OTHERWISE WITH RESPECT TO ANY EQUIPMENT, WHETHER EXPRESS, IMPLIED OR STATUTORY, INCLUDING WARRANTIES OF MERCHANTABILITY AND FITNESS FOR A PARTICULAR PURPOSE, AND LANDOLL COMPANY, LLC SHALL NOT BE LIABLE FOR SPECIAL OR CONSEQUENTIAL DAMAGES OF ANY KIND ON ACCOUNT OF ANY LANDOLL PRODUCT. NO EMPLOYEE OR REPRESENTATIVE IS AUTHORIZED TO CHANGE THIS WARRANTY, VERBALLY OR IN WRITING, OR GRANT ANY OTHER WARRANTY. LANDOLL COMPANY, LLC, WHOSE POLICY IS ONE OF CONTINUOUS IMPROVEMENT, RESERVES THE RIGHT TO MAKE CHANGES WITHOUT OBLIGATION TO MODIFY PREVIOUSLY PRODUCED EQUIPMENT.

This warranty does not expand, enlarge upon or alter in any way, the warranties provided by the original manufacturers and suppliers of component parts and accessories. This warranty excludes such parts or accessories which are not defective, but may wear out and have to be replaced during the warranty period, including, but not limited to, light bulbs, paint, and the like. (Tire Warranties are expressly excluded from Landoll Company, LLC warranty herein.) Purchaser is expected to pay all repairs or replacement costs, in connection with this Agreement, including sales and other taxes immediately upon completion of work performed.

LIMITATION OF LIABILITY: Landoll Company, LLC shall not be liable to purchaser for any incidental or consequential damages suffered by the purchaser, including, but not limited to, any commercially reasonable charges, expenses or commissions incurred in connection with effecting cover or any other reasonable expense incident to the delay or other breach of warranty by Landoll Company, LLC, loss of anticipated profits, transportation expenses due to repairs, non-operation or increased expense of operation costs of purchased or replaced equipment, claim of customers, cost of money, any loss of use of capital or revenue, equipment rental, service trips, or for any special damage or loss of any nature arising at any time or from any cause whatsoever.

LIMITATION OF REMEDY: In the event of Landoll Company, LLC failure to repair the product subject to the warranty contained herein, the purchaser's sole and exclusive remedy against Landoll Company, LLC shall be for the repair or replacement of any defective part or parts of the product subject to work or repair within the time period and manner set forth herein. This exclusive remedy shall not be deemed to have failed of its essential purpose so long as Landoll Company, LLC is willing and able to repair or replace defective parts in the prescribed manner.

Figure 2-3: Landoll Tillage Product Warranty (2 of 2)

General Torque Specifications

LANDOLL
FASTENER TORQUE SPECIFICATIONS
(Rev. 23/04)

This chart provides general torque specifications for Standard Nuts and Caps Screws (as received condition) that are not called out on processes or drawings.



This **DOES NOT** apply if special lubrication such as graphite moly-disulfide or other extreme pressure lubricants are used.

Add 33% to the listed torque specification if the fastener is dry (solvent cleaned).

Cap screw grades are indicated by markings on the head, these vary among manufacturers.

Thick Nuts must be used on grade 8 cap screws.



SAE TORQUE SPECIFICATIONS (FOOT-POUNDS)
[] Indicates specifications for Prevailing Torque Nuts.

UNC Size	 Grade 2	 Grade 5	 Grade 8
1/4 - 20	4 [5]	6 [7]	9 [11]
5/16 - 18	8 [10]	13 [16]	18 [22]
3/8 - 16	15 [19]	23 [29]	35 [43]
7/16 - 14	24 [30]	35 [43]	55 [62]
1/2 - 13	35 [43]	55 [62]	80 [100]
9/16 - 12	55 [62]	80 [100]	110 [137]
5/8 - 11	75 [94]	110 [137]	170 [212]
3/4 - 10	130 [162]	200 [250]	280 [350]
7/8 - 9	125 [156]	320 [400]	460 [575]
1 - 8	190 [237]	408 [506]	680 [850]
1-1/8 - 7	270 [337]	600 [750]	960 [1200]
1-1/4 - 7	380 [475]	840 [1050]	1426 [1782]
1-3/8 - 6	490 [612]	1100 [1375]	1780 [2225]
1-1/2 - 6	650 [812]	1460 [1825]	2360 [2950]

See back side for SAE UNF and Metric torques.

Form No. F-257-0322

SAE TORQUE SPECIFICATIONS (FOOT POUNDS)
[] Indicates specifications for Prevailing Torque Nuts.

UNF Size	 Grade 2	 Grade 5	 Grade 8
1/4 - 28	5 [6]	7 [9]	10 [12]
5/16 - 24	9 [11]	14 [17]	20 [25]
3/8 - 24	17 [21]	25 [31]	35 [44]
7/16 - 20	27 [34]	40 [50]	60 [75]
1/2 - 20	40 [50]	65 [81]	90 [122]
9/16 - 18	60 [75]	90 [112]	130 [162]
5/8 - 18	85 [106]	130 [162]	180 [225]
3/4 - 16	150 [188]	220 [275]	320 [400]
7/8 - 14	140 [175]	360 [450]	500 [625]
1 - 14	210 [263]	540 [675]	760 [950]
1-1/8 - 12	300 [375]	660 [825]	1080 [1350]
1-1/4 - 12	420 [525]	920 [1150]	1500 [1875]
1-3/8 - 12	560 [700]	1260 [1575]	2010 [2512]
1-1/2 - 12	730 [912]	1640 [2050]	2660 [3325]

METRIC TORQUE SPECIFICATIONS
This chart provides torque specification for phosphate coated, Rockwell "C" 38-45 Metric Coarse Thread Class 10.9 Fasteners, Class 10.0 Nuts and Harden Flat Washers.

[] Indicates specifications for Prevailing Torque Nuts.

MM Size	Newton - Meters	Foot-Pounds
6	10 [14]	7 [10]
7	16 [22]	12 [16]
8	23 [32]	17 [24]
10	46 [60]	34 [47]
12	80 [101]	60 [75]
14	125 [155]	90 [115]
16	200 [240]	150 [180]
18	275 [330]	205 [245]
20	385 [450]	290 [335]
24	670 [775]	500 [625]
27	980 [1105]	730 [825]
30	1330 [1470]	990 [1090]
33	1790 [1950]	1730 [1870]
36	2325 [2515]	1730 [1870]
39	3010 [3210]	2240 [2380]

See front side for SAE UNC and notes.

Figure 2-4: General Torque Specifications

Hydraulic Fitting Torque Specifications

LANDOLL HYDRAULIC FITTING TORQUE SPECIFICATIONS (REV. 23/04) AEROQUIP BRAND FITTINGS 37° JIC; ORS & ORB			
This chart provides torque specifications for Plated Carbon Steel and Stainless Steel Fittings (as received condition) that are not called out on processes or drawings. This DOES NOT apply if special lubrication such as graphite moly-disulfide or other extreme pressure lubricants are used. Minus 65% from the listed torque specification for Brass Fittings.			
TORQUE SPECIFICATIONS (FOOT-POUNDS) [] Indicates specifications for Prevailing Torque Nuts.			
DASH Size	37 Degree JIC	O-Ring (ORS)	O-Ring Boss (ORB)
-4	11-12	10-12	14-16
-5	15-16	-----	18-20
-6	18-20	18-20	24-26
-8	38-42	32-35	50-60
-10	57-62	46-50	72-80
-12	79-87	65-70	125-135
-14	-----	-----	160-180
-16	108-113	92-100	200-220
-20	127-133	125-140	240-280
-24	158-167	150-165	270-360
-32	245-258	-----	-----
FORM NO. F-263-2304 (1 of 3)			

LANDOLL HYDRAULIC FITTING TORQUE SPECIFICATIONS (REV. 23/04) GATES BRAND FITTINGS 37° JIC; ORS & ORB			
This chart provides torque specifications for Plated Carbon Steel and Stainless Steel Fittings (as received condition) that are not called out on processes or drawings. This DOES NOT apply if special lubrication such as graphite moly-disulfide or other extreme pressure lubricants are used. Minus 65% from the listed torque specification for Brass Fittings.			
TORQUE SPECIFICATIONS (FOOT-POUNDS) [] Indicates specifications for Prevailing Torque Nuts.			
DASH Size	37 Degree JIC	O-Ring (ORS)	O-Ring Boss (ORB)
-4	10-11	10-12	14-16
-5	13-15	-----	-----
-6	17-19	18-20	24-26
-8	34-38	32-40	37-44
-10	50-56	46-56	50-60
-12	70-78	65-80	75-83
-14	-----	65-80	-----
-16	94-104	92-105	111-125
-20	124-138	125-140	133-152
-24	156-173	150-180	156-184
-32	219-243	-----	-----
FORM NO. F-263-2304 (2 of 3)			

LANDOLL HYDRAULIC FITTING TORQUE SPECIFICATIONS (REV. 23/04) PARKER BRAND FITTINGS 37° JIC; ORS & ORB			
This chart provides torque specifications for Plated Carbon Steel and Stainless Steel Fittings (as received condition) that are not called out on processes or drawings. This DOES NOT apply if special lubrication such as graphite moly-disulfide or other extreme pressure lubricants are used. Minus 65% from the listed torque specification for Brass Fittings.			
TORQUE SPECIFICATIONS (FOOT-POUNDS) [] Indicates specifications for Prevailing Torque Nuts.			
DASH Size	37 Degree JIC	O-Ring (ORS)	O-Ring Boss (ORB)
-4	11-13	15-17	13-15
-5	14-16	-----	21-23
-6	20-22	34-36	25-29
-8	43-47	58-62	40-44
-10	55-65	100-110	58-62
-12	80-90	134-146	75-85
-14	-----	-----	-----
-16	115-125	202-218	109-121
-20	160-180	248-272	213-237
-24	185-215	303-327	238-262
-32	250-290	-----	310-340
FORM NO. F-263-2304 (3 of 3)			

Figure 2-5: Hydraulic Fitting Torque Specifications

Model Specifications

5532 SERIES GRAIN DRILL						
Model Number	Working Width	Row Spacing	No. of Openers	Transport Width	Tire and Wheels	Estimated Weight
5532-30X7.5	30' - 0"	7-1/2"	48	14' - 6"	(4) 380/55R16.5 (Center) (4) 280/70R15 6 Bolt (Wing)	18,450 LBS.
5532-30X10	30' - 0"	10"	36	14' - 6"		17,010 LBS.
5532-40X7.5	40' - 0"	7-1/2"	64	14' - 6"		24,560 LBS.
5532-40X10	40' - 0"	10"	48	14' - 6"		22,640 LBS.

NOTE: Specifications Are Subject To Change Without Prior

5532 SERIES GRAIN DRILL W/FERTILIZER						
Model Number	Working Width	Row Spacing	No. of Openers	Transport Width	Tire and Wheels	Estimated Weight
5532-30X7.5	30' - 0"	7-1/2"	48	14' - 6"	(4) 380/55R16.5 (Center) (4) 280/70R15 6 Bolt (Wing)	19,215 LBS.
5532-30X10	30' - 0"	10"	36	14' - 6"		17,710 LBS.
5532-40X7.5	40' - 0"	7-1/2"	64	14' - 6"		25,547 LBS.
5532-40X10	40' - 0"	10"	48	14' - 6"		23,540 LBS.

NOTE: Specifications Are Subject To Change Without Prior

5532 SERIES GRAIN DRILL W/SMALL GRASS SEED						
Model Number	Working Width	Row Spacing	No. of Openers	Transport Width	Tire and Wheels	Estimated Weight
5532-30X7.5	30' - 0"	7-1/2"	48	14' - 6"	(4) 380/55R16.5 (Center) (4) 280/70R15 6 Bolt (Wing)	19,344 LBS.
5532-30X10	30' - 0"	10"	36	14' - 6"		17,751 LBS.
5532-40X7.5	40' - 0"	7-1/2"	64	14' - 6"		25,648 LBS.
5532-40X10	40' - 0"	10"	48	14' - 6"		23,549 LBS.

NOTE: Specifications Are Subject To Change Without Prior

TABLE OF CONTENTS

5532 SERIES GRAIN DRILL CAPACITIES

Model	Seed Box Capacity	Seed/Fertilizer		Small Seed Box Capacity
		Seed Box Capacity	Fertilizer Box Capacity	
5532-30'	97.5 Bushels	60 Bushels	3150 LBS.	10.8 Bushels
5532-40'	130 Bushels	80 Bushels	4200 LBS.	14.1 Bushels

NOTE: Specifications Are Subject To Change Without Prior

Tire Inflation

Tire Size	Tire Manufacturer	Ply/Load Rating	Inflation Pressure (Psi) (Max.)
280/70R15	Firestone	LOAD INDEX 134/4680 LBS. @ 40MPH	64 psi
380/55RX16.5 IMP	BKT	LOAD INDEX 150A8/B/7400 LBS. @ 30MPH	74 psi

Recommended Torque Specification For Lug Bolts and Nuts

Bolt Size	Torque (FT. LBS.)
5/8-18	85 - 100 FT. LBS.
9/16-18	80 - 90 FT. LBS.

Drive Placement

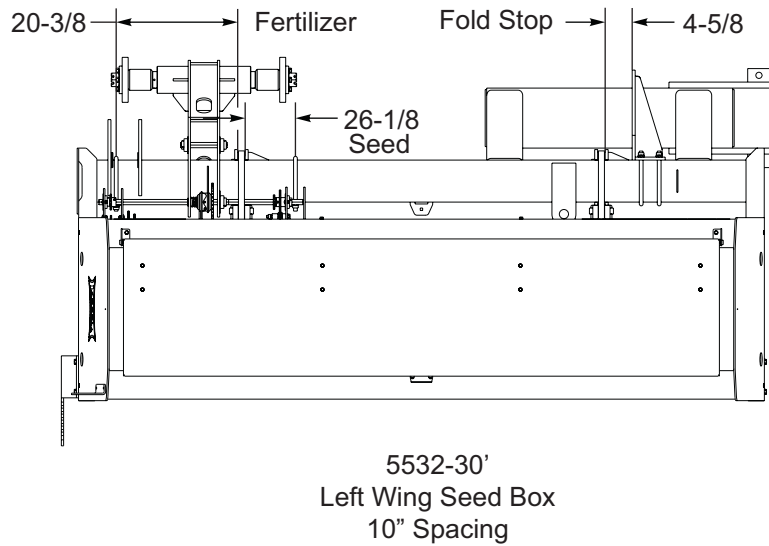
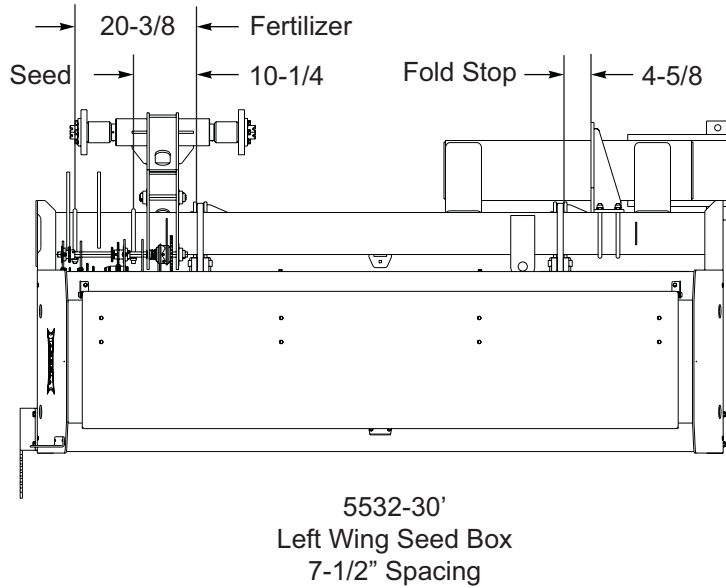
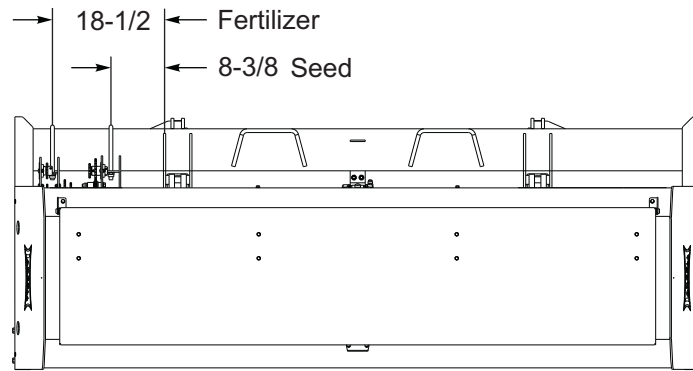
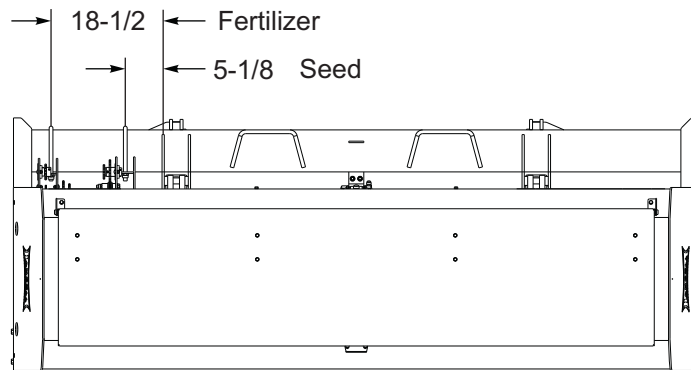

Figure 2-6: 5532-30 Left Wing Placement

TABLE OF CONTENTS



5532-30'
Center Seed Box
7-1/2" Spacing



5532-30'
Center Seed Box
10" Spacing

Figure 2-7: 5532 Center Placement

TABLE OF CONTENTS

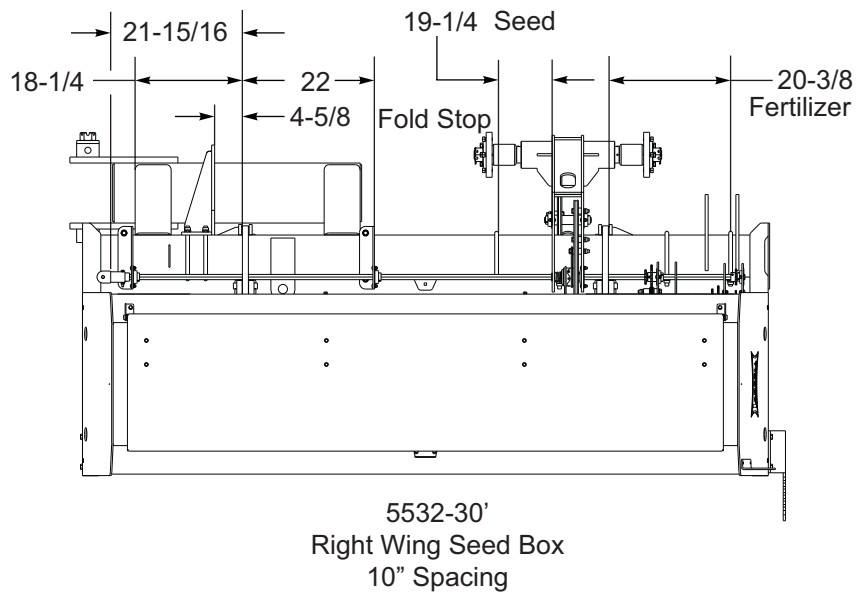
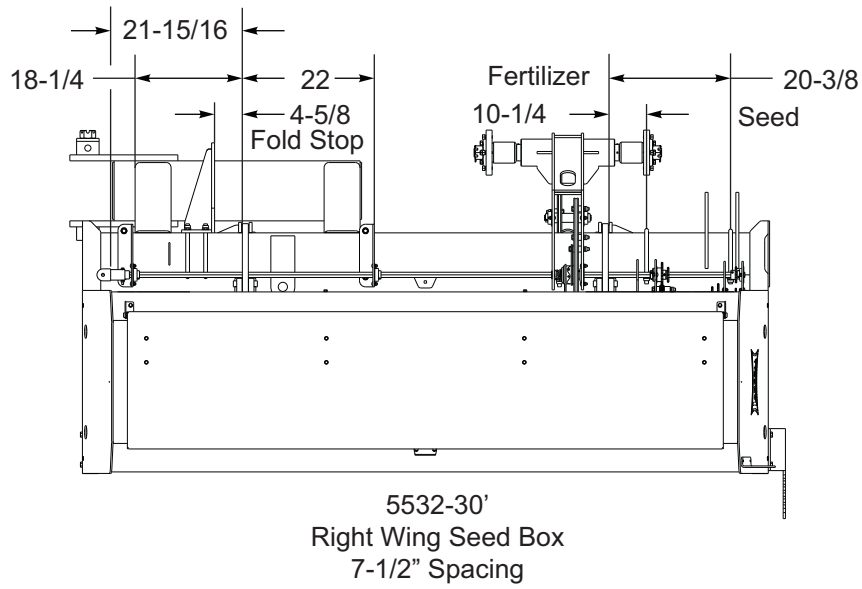
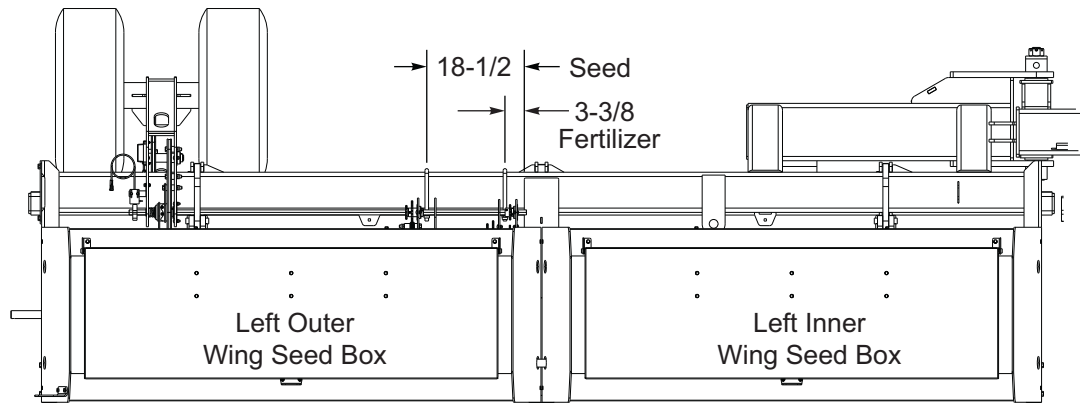
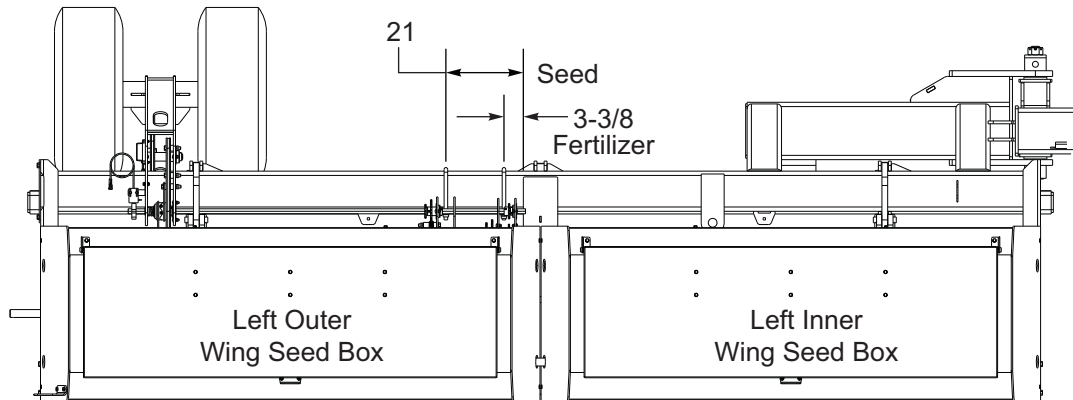

Figure 2-8: 5532-30 Right Wing Placement

TABLE OF CONTENTS



5532-40'
Left Wing Seed Boxes
7-1/2" Spacing



5532-40'
Left Wing Seed Boxes
10" Spacing

Figure 2-9: 5532-40 Left Wing Placement

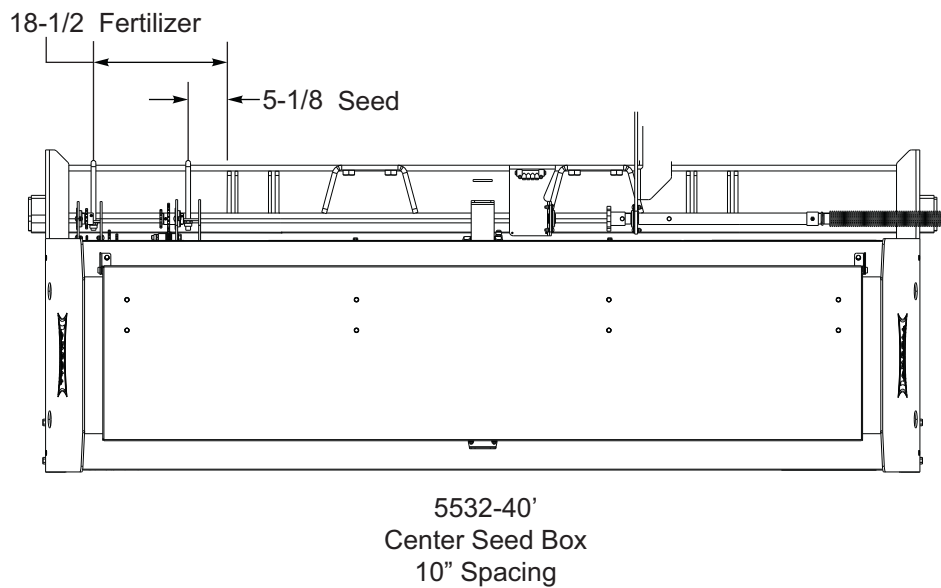
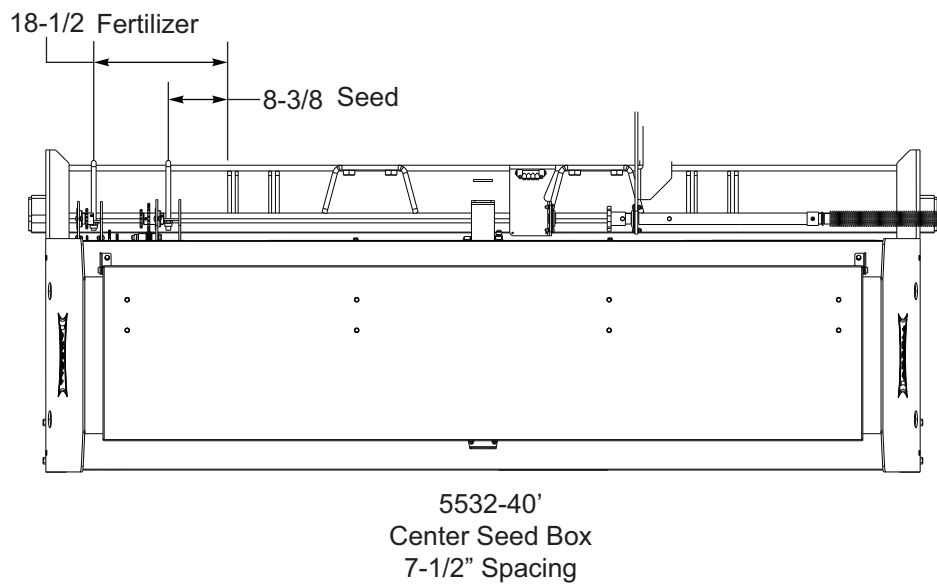

Figure 2-10: 5532-40 Center Placement

TABLE OF CONTENTS

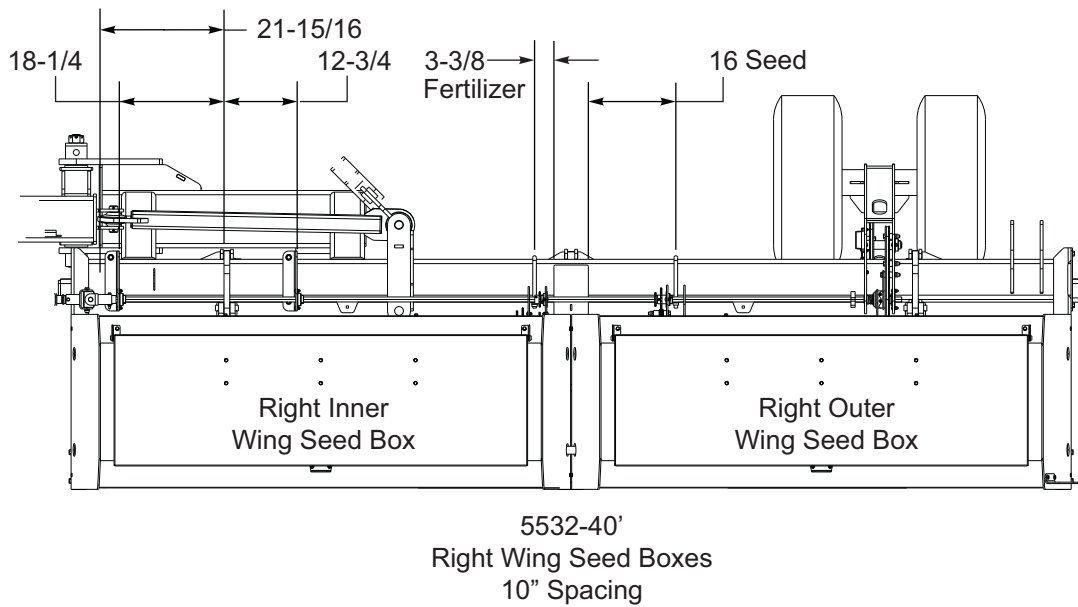
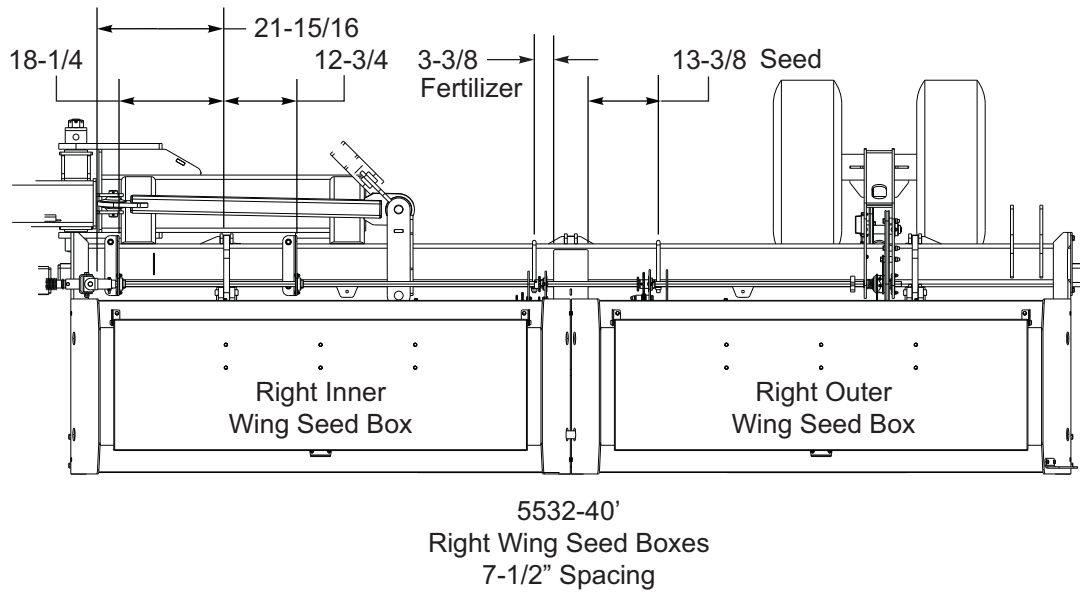

Figure 2-11: 5532-40 Right Wing Placement

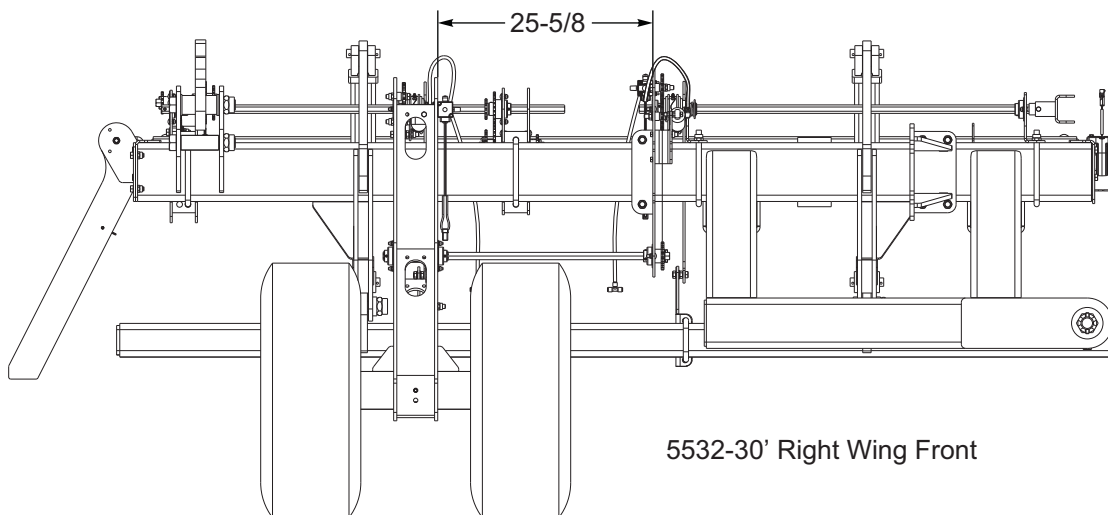
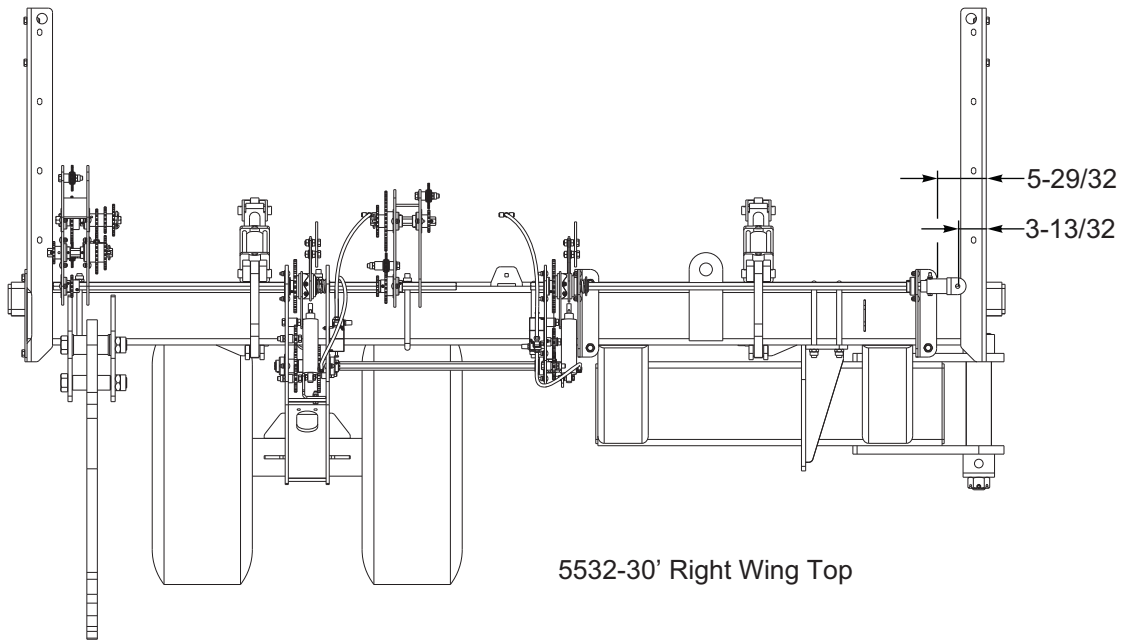

Figure 2-12: 5532-30 Point Row Clutch Placement

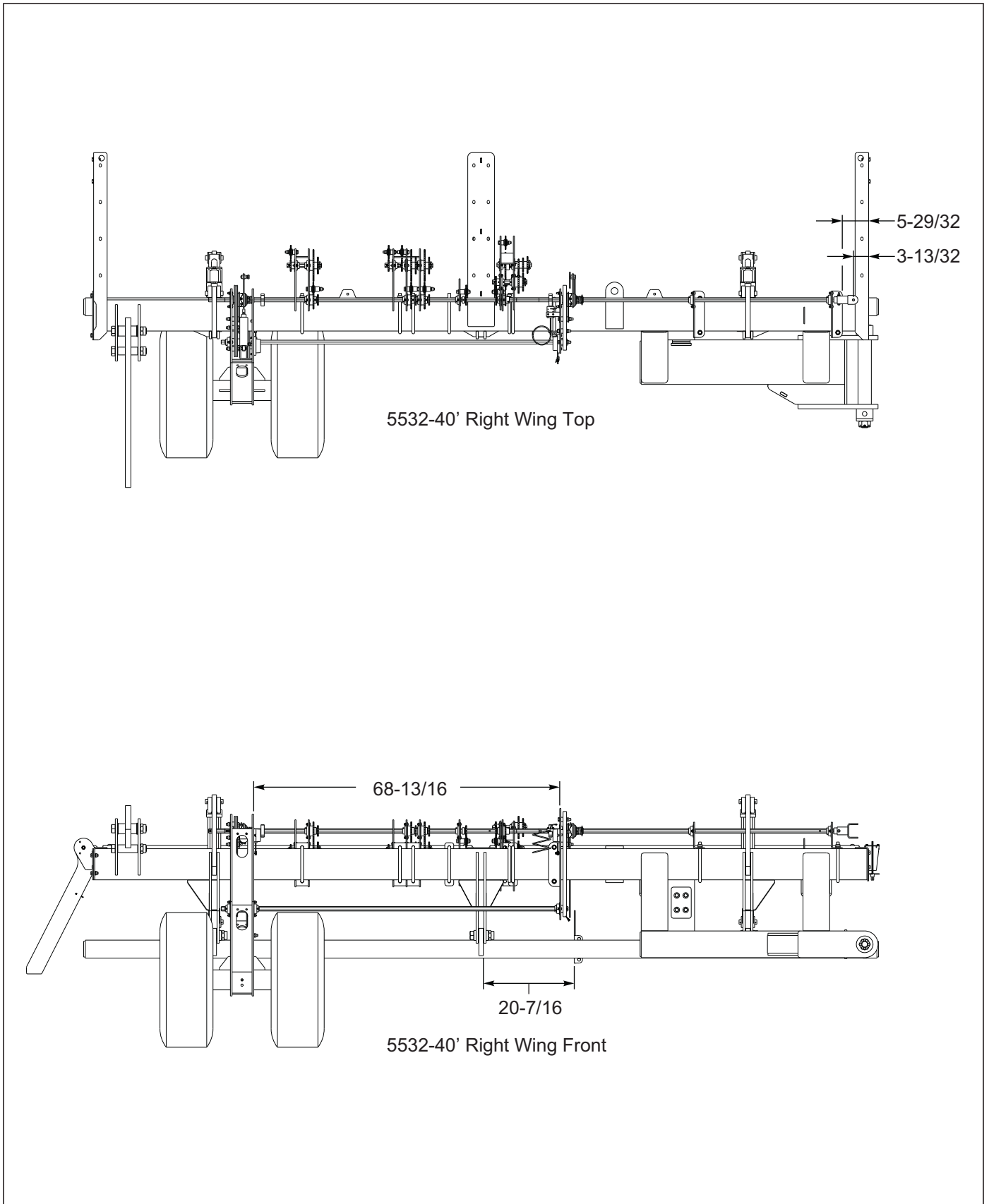

Figure 2-13: 5532-40 Point Row Clutch Placement

Assembly Instructions

Assembly Safety

Your new 5532 Grain Drill comes nearly completely assembled from the factory and ready to go to the field. This section includes press wheel and option assembly procedures.

To insure alignment of assemblies, **leave the nuts loose until completion** of final assembly. Use lock washers or flat washers as specified. Spread all cotter pins.

After completion of final assembly, tighten all nuts evenly to prevent misalignment, distortion or binding.

Tighten all screws and nuts to the recommended torques (SEE PAGE 2-4).



DANGER

Opener blades are extremely sharp. Exercise extreme care when working on or near opener blades. Do not allow opener blades to roll over or fall onto any body part. Do not allow wrenches to slip when working near blades. Never push wrenches toward opener blades. Do not climb over machine above opener blades. Failure to stay clear of opener blade edges can cause serious personal injury or death.



WARNING

Do not attempt to lift heavy parts (such as the frame, wheel lift, and pull hitch) manually. Use a hoist or a forklift to move these parts into position.



DANGER

To prevent accidental lowering:

- All hydraulically elevated equipment must be locked out using the cylinder lockouts.
- Lower equipment to the ground while servicing or when it is idle.
- Failure to take measures to prevent accidental lowering may result in serious personal injury or death.



CAUTION

Be sure to bleed the hydraulic system of all air in lines after installation. Failure to bleed the system of all air can result in improper machine operation.

Press Wheel Assembly

1. Attach each press wheel assembly to each air opener assembly on the Grain Drill using press wheel arm pin and 3/4 lock nut *See Figure 3-1.*
2. Attach each press wheel assembly to each spring opener assembly on the Grain Drill using press wheel with press wheel arm bushing, 5/8 x 4 bolt and 5/8 flange head nut *See Figure 3-1.*



DANGER

Opener blades are extremely sharp. Exercise extreme care when working on or near opener blades. Do not allow opener blades to roll over or fall onto any body part. Do not allow wrenches to slip when working near blades. Never push wrenches toward opener blades. Do not climb over machine above opener blades. Failure to stay clear of opener blade edges can cause serious personal injury or death.

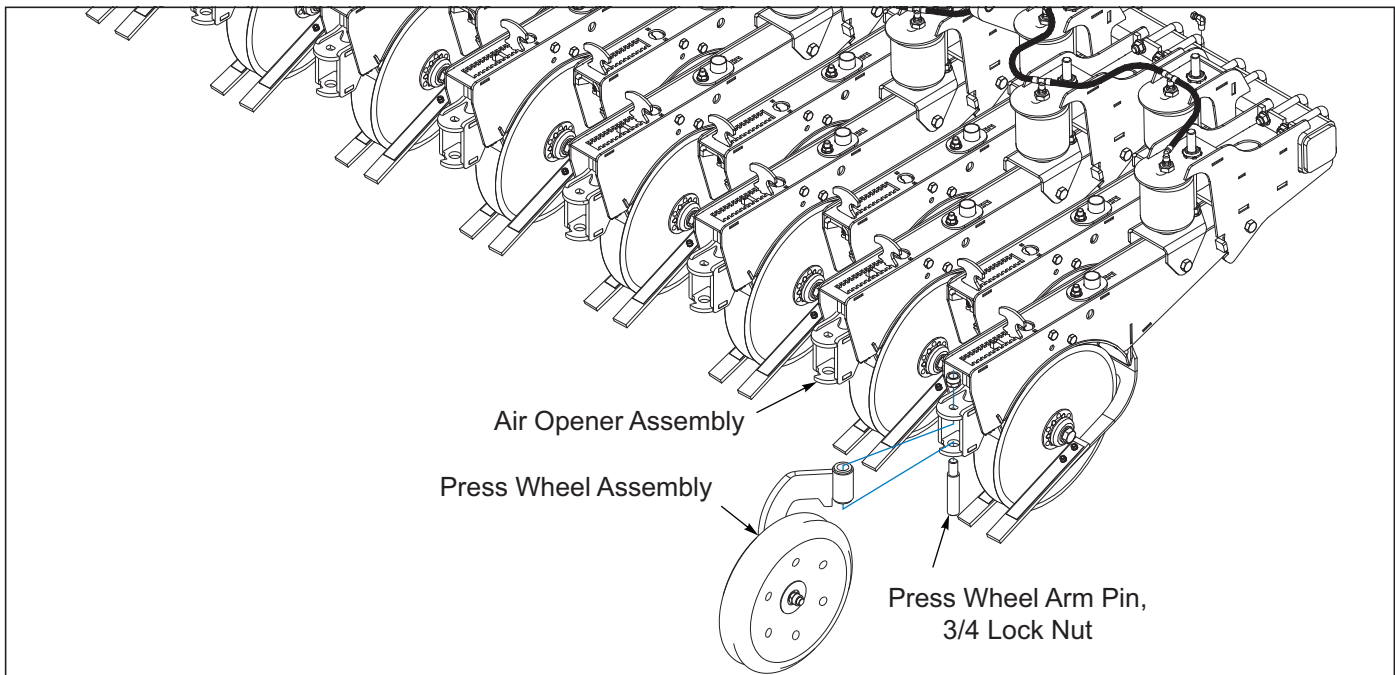

Figure 3-1: Air Opener Press Wheel Assembly

Small Seed Attachment Installation (Option)

See Figures 3-3 for small seed attachment overview. Use these instructions to install the optional small seed attachment to the rear main seed box of the 5532 Grain Drill.

1. Attach the drill to the tractor and lower the unit to the ground. Leave the drill attached to the tractor while assembling the small seed attachment. This will prevent tipping of the drill.
2. Remove the SMV sign from the rear of the existing seed box. Reinstall the mounting screws in the seed box to plug the holes.
3. Remove the 3/8 x 3/4" flange head screws from the rear of each seed box
4. Remove the 3/8" hex lock nuts and 2-hole mounting plates from the front of the small seed box assembly **See Figure 3-3**.
5. Carefully raise the small seed attachment and insert the mounting screws through the holes drilled in the rear of the main seed box. Install the 2-hole mounting plates and 3/8" hex lock nuts on the inside of the main drill box to secure the small seed attachment.
6. Attach the chain wear pad to the seed box bracket with 3/8 x 1" hex screws and lock nuts in the forward set of mounting holes.
7. Remove the three outer locking nuts on the seed shaft bearing assembly **See Figure 3-4**. Slide the bearing assembly over the small seed square meter shaft. Insert the bearing assembly mounting screws into the small seed drive mount located on the end of the small seed box assembly. Loosely install the three locking nuts to hold the bearing assembly in place.
8. Just in front of the small seed bearing assembly, remove the rear 1/2-13 x 1-1/4 hex head cap screw from the existing seed box bracket **See Figure 3-2**.

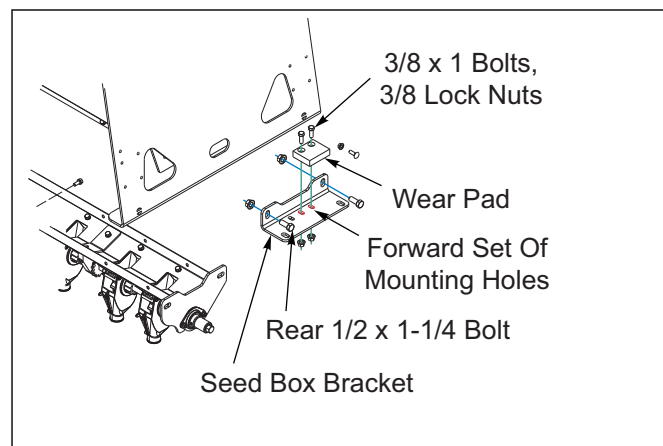

Figure 3-2: Removal of Rear Screw from Existing Seed Box Bracket

TABLE OF CONTENTS

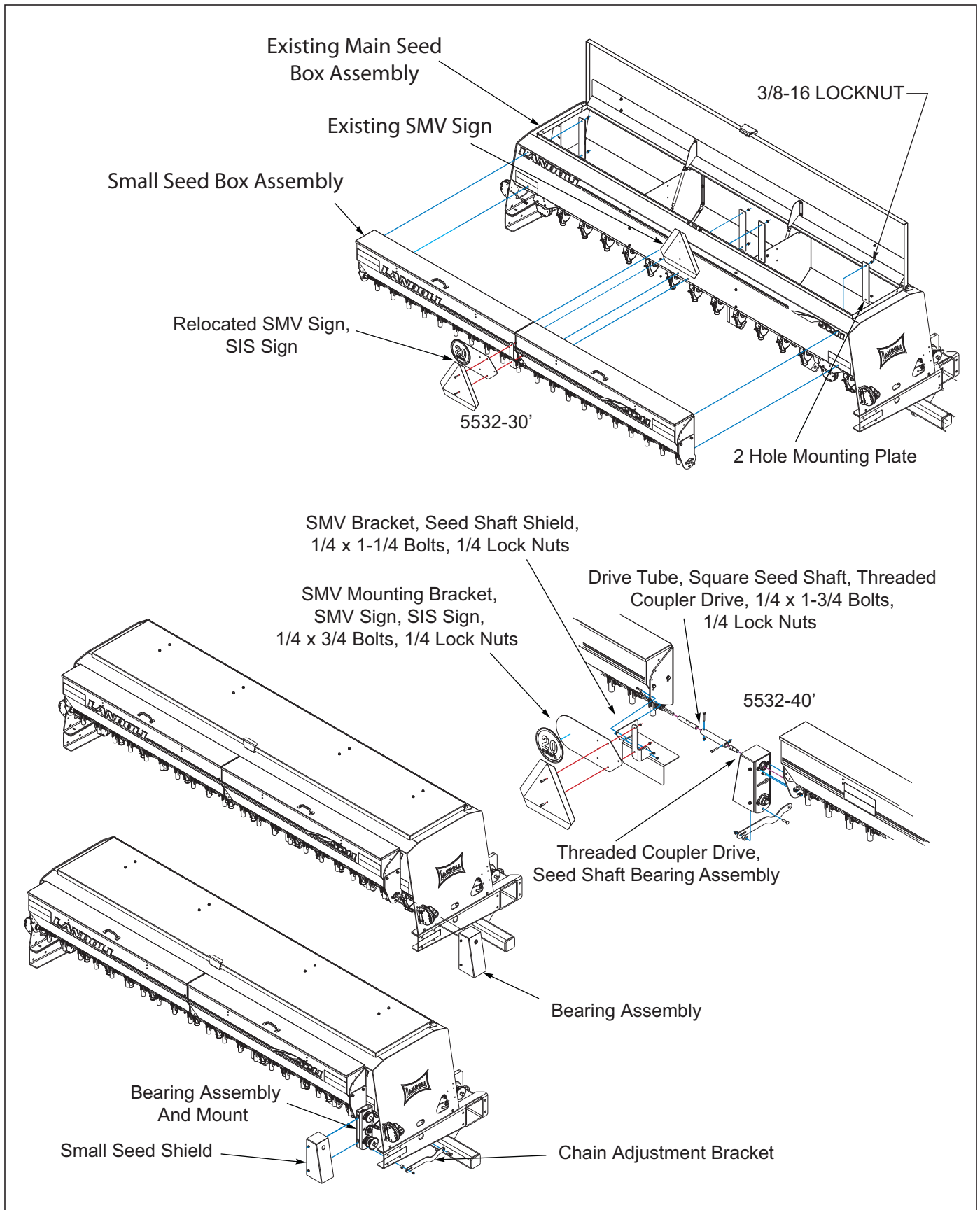

Figure 3-3: Small Seed Assembly Overview

9. Attach the front of the chain adjustment bracket to the seed box bracket with the 1/2-13 x 1-1/4 hex head cap screw.
10. Attach the slotted rear hole of the chain adjustment bracket to the outer hole of the small seed bearing assembly with a 5/16-18 x 1-1/2 round head square neck screw, 1" OD spacer and hex flange nut **See Figure 3-4.**

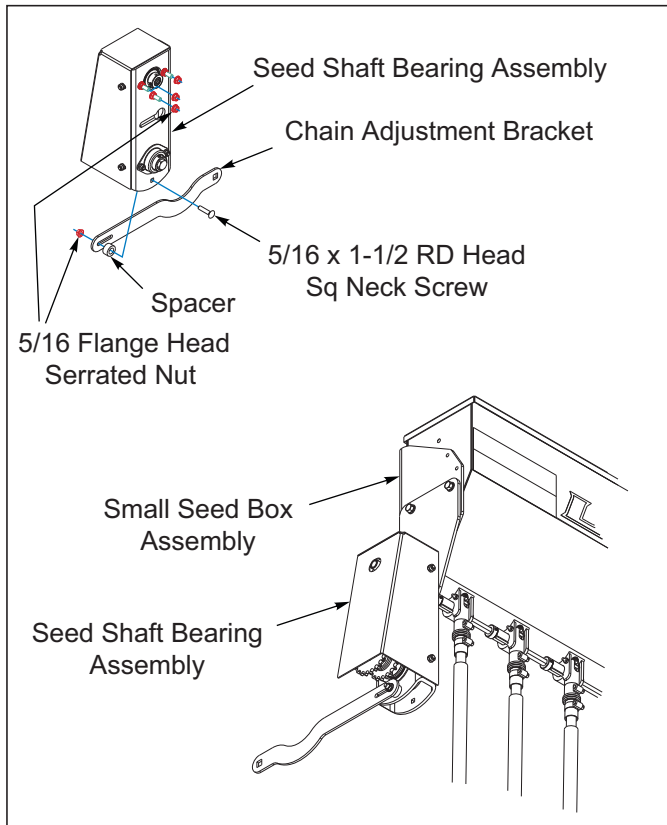

Figure 3-4: Attaching Chain Adjustment Bracket to Small Seed Bearing Assembly

11. Remove rear walkboard and right and left mounting brackets. Using existing screws, install new extended walkboard mounts to the rear of the drill frame. Reattach walkboard to new extended mounts.

NOTE

*For 30' drills – If the drill has the optional dry fertilizer attachment, the grass seed bracket and bearing will not be used, go to **step 13.***

*For 40' drills – If the drill has the optional dry fertilizer attachment, the grass seed bracket and bearing will not be used on the center section, go to **step 13.***

12. Remove existing 7/8 hex drive shaft above the drill 7 x 7 frame tube. Install the grass seed bracket and bearing to the rear of the main drill 7 x 7 frame. **See Figure 3-5 for proper placement.** Reinstall the hex drive shaft, see placement dimensions.
13. Install the 24 tooth drive sprocket and locking set screw on the end of the hex drive shaft **See Figure 3-5 for proper placement.**
14. Remove the rear safety shield from the seed shaft bearing assembly. Loosen the rear mounting screws, then lift up and remove the shield and screws.
15. Install the connecting link in the roller chain, and install between the front 24 tooth drive sprocket and outer bearing on the seed shaft bearing assembly. Loosen the 5/16-18 flange head serrated nut through the chain adjustment bracket. Pull the lower end of the seed shaft bearing assembly rearward to tighten the drive chain. Retighten the 5/16-18 flange head serrated nut and the three hex lock nuts that attach the seed shaft bearing assembly to the mount on the end of the small seed box. Verify drive chain alignment, and adjust front 24 tooth sprocket if necessary.
16. Reinstall the safety shield over the seed shaft bearing assembly.
17. For 40' drills, wing braces screw the threaded coupler drive into the open end of the seed shaft bearing assembly on each wing **See Figure 3-3.** Slide the square end of the drive tube over the square seed shaft of the left small seed box. Connect the drive tube and threaded coupler drive with the 6" shaft coupler using 1/4-20 x 1-3/4 hex head cap screws and hex lock nuts.
18. Install the metal small seed tubes in the mounting holes in each drill opener frame using 1/4-20 x 1 round head square neck screws and nuts. Note the lower end of the small seed tube points rearward towards the press wheels. The seed tube has two sets of mounting holes. Initially slide the seed tube forward. The tube may be positioned farther back for shallower planting depth if desired.
19. Attach the seed tube assemblies to the small seed box and small seed tubes on the opener.
20. Attach the SMV sign and SIS sign to the SMV mounting bracket with 1/4-20 x 3/4 hex head cap screws and hex lock nuts. Using 1/4-20 x 1-1/4 hex head cap screws and hex lock nuts, attach the SMV and bracket to the seed box mounting bracket extending below the small seed boxes in the center of the machine **See Figure 3-3.**

TABLE OF CONTENTS

1. Install the grass seed brackets 158309 & 158310 to the rear of the main drill frame 7 x 7 tube using u-bolts

and 5/8 nuts. Attach the brackets as shown, **See Figure 3-5** for locations 5531-30'-40'.

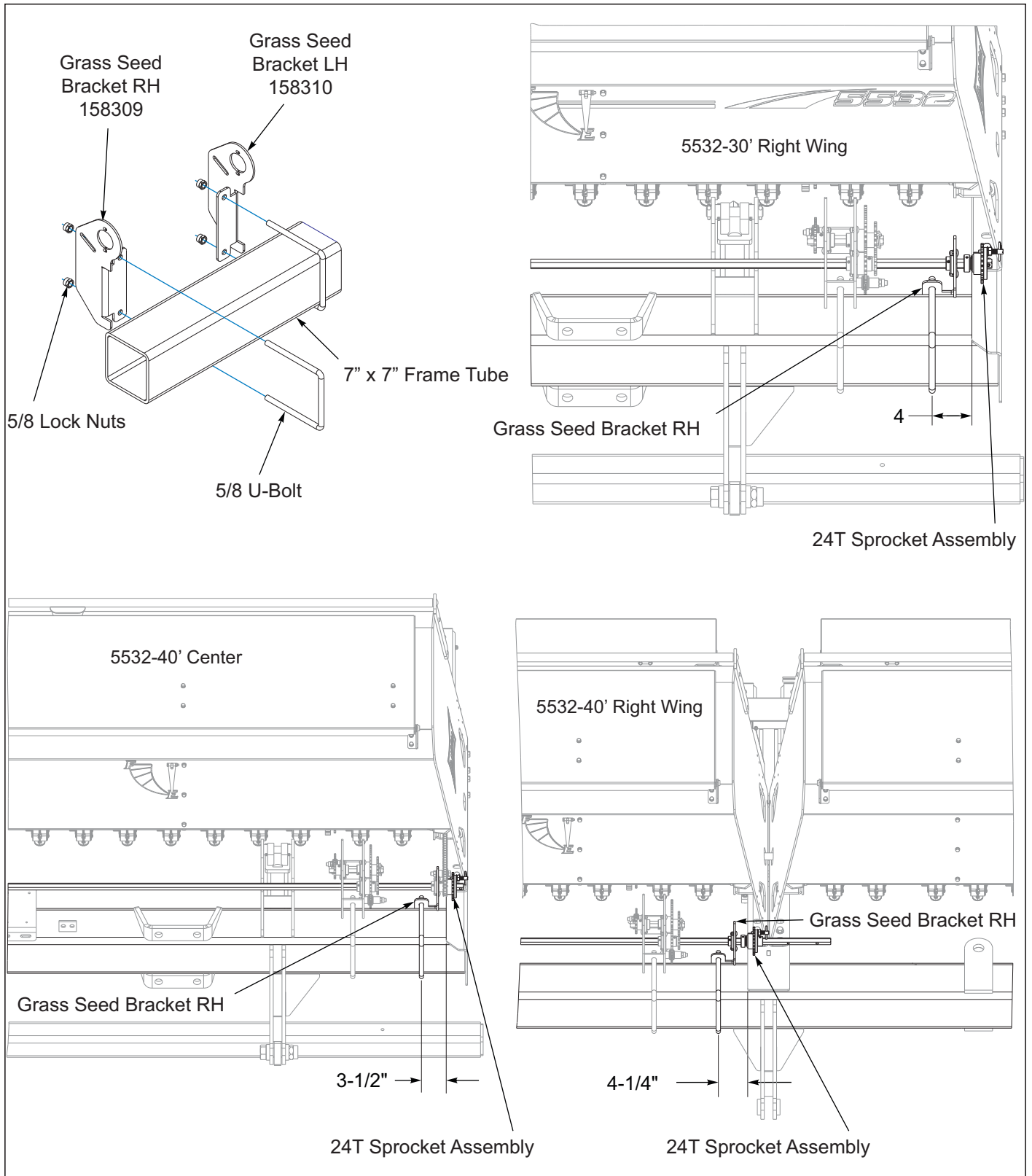

Figure 3-5: Small Seed Bracket Placement

Agitator Assembly (Option)

and 5/8 nuts. Attach the brackets as shown, *See Figure 3-6* for locations 5531-30'-40'.

1. Install the grass seed brackets 158309 & 158310 to the rear of the main drill frame 7 x 7 tube using u-bolts

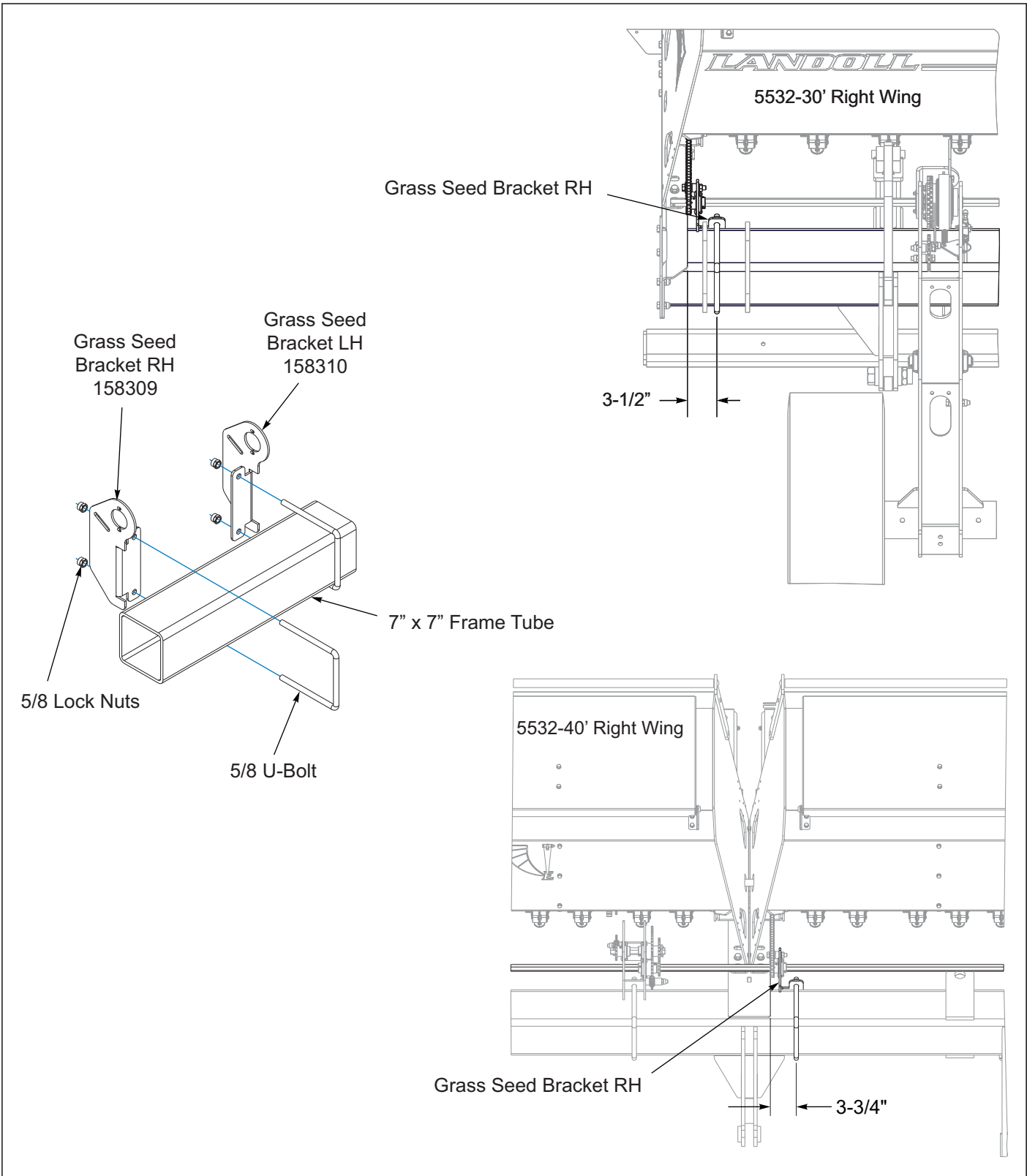

Figure 3-6: Agitator Bracket Placement

2. Remove the agitator hole covers inside of the seed boxes. **See Figure 3-7.**

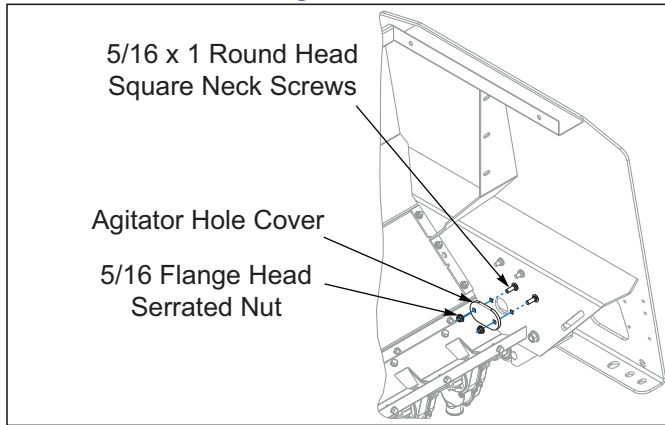

Figure 3-7: Agitator Hole Covers

3. Replace the 144127 seed box bracket, with the 168902 agitator bracket on the outer ends of the seed boxes **See Figure 3-9.**
4. Model 5532-30' install the new 72-1/4" long hex shaft above the 7 x 7 frame, left wing. Connect the two shafts together in the center of the drill with a hex coupler, 1/4 x 2 hex screws, and lock nuts.
5. Slide a 15-tooth hex bore sprocket over the outer drive end of each new hex shaft and secure with a 5/16 x 3/8 long set screw.
6. Attach the idler sprocket to the slotted hole in both grass seed brackets, using a 1/2 x 2-1/2 flange head screw, 1" spacer, idler sprocket, and locknut.
7. Install the plastic bearing into the small OD end of each bearing mount. Assemble the bearing mount w/bearing into each end of the drill seed box. The flange of the bearing mount will be on the inside of the drill box. Use 5/16 x 3/4 flange head screws and lock nuts.
8. Assemble a bearing mount w/bearing into the agitator shaft bearing bracket with 5/16 x 3/4 flange head screws. The flange will be on the opposite side of the agitator formed ears. This will be the center support for the square agitator shaft. This assembly will be approximately centered in the seed box between the meters. The holes will need to be drilled in the bottom of the seed box. Do not drill the holes until the rest of the agitator is assembled to be able to properly center the bearing **See Figure 3-8.**

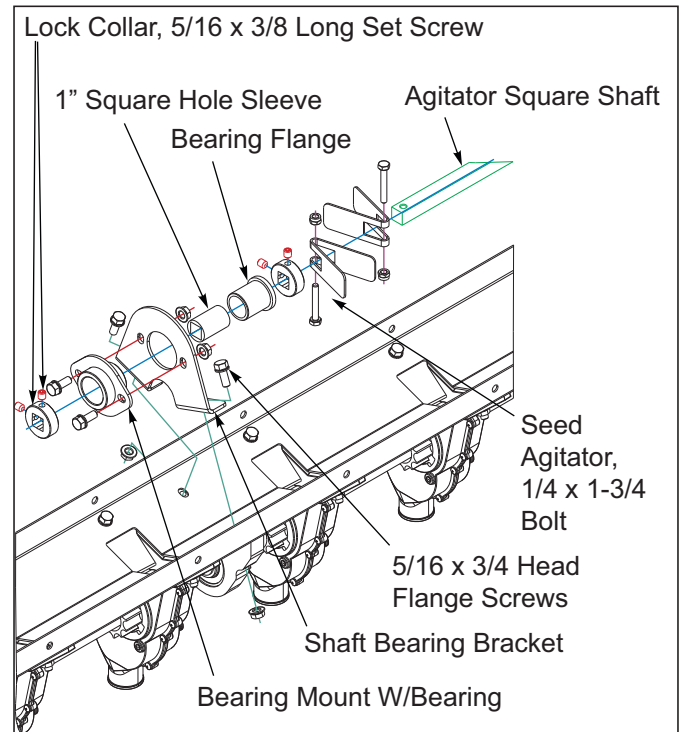

Figure 3-8: Middle Bearing Mount Installation

9. Install a 1" long square-holed sleeve in each bearing.
10. Insert the agitator square shaft through the outer seed box bearing, center agitator bracket and bearing, and inner seed box bearing. A lock collar is used on each side of each agitator bearing except the very outside of the box where the sprocket will attach.
11. Install the 15-tooth sprocket on the outer ends of each agitator shaft. Secure sprocket with a 1/4 x 1-1/2 spring pin.
12. Starting from the outside, slide the sprocket against the agitator bearing. Slide the lock collars against each side of the agitator bearings and tighten. Make sure the agitator shaft will rotate freely and not bind.
13. Install two seed agitators over each seed meter opening using 1/4 x 1-3/4 hex screws and lock nuts. Agitators should be installed on opposite sides of the agitator shaft. Make sure the shafts will turn freely and not bind or catch on anything after assembly **See Figure 3-10.**
14. Install an idler sprocket, 17/32 spacer, (3) flat washers, 1/2 x 3 screw, and locknut in the front seed box bracket hole.

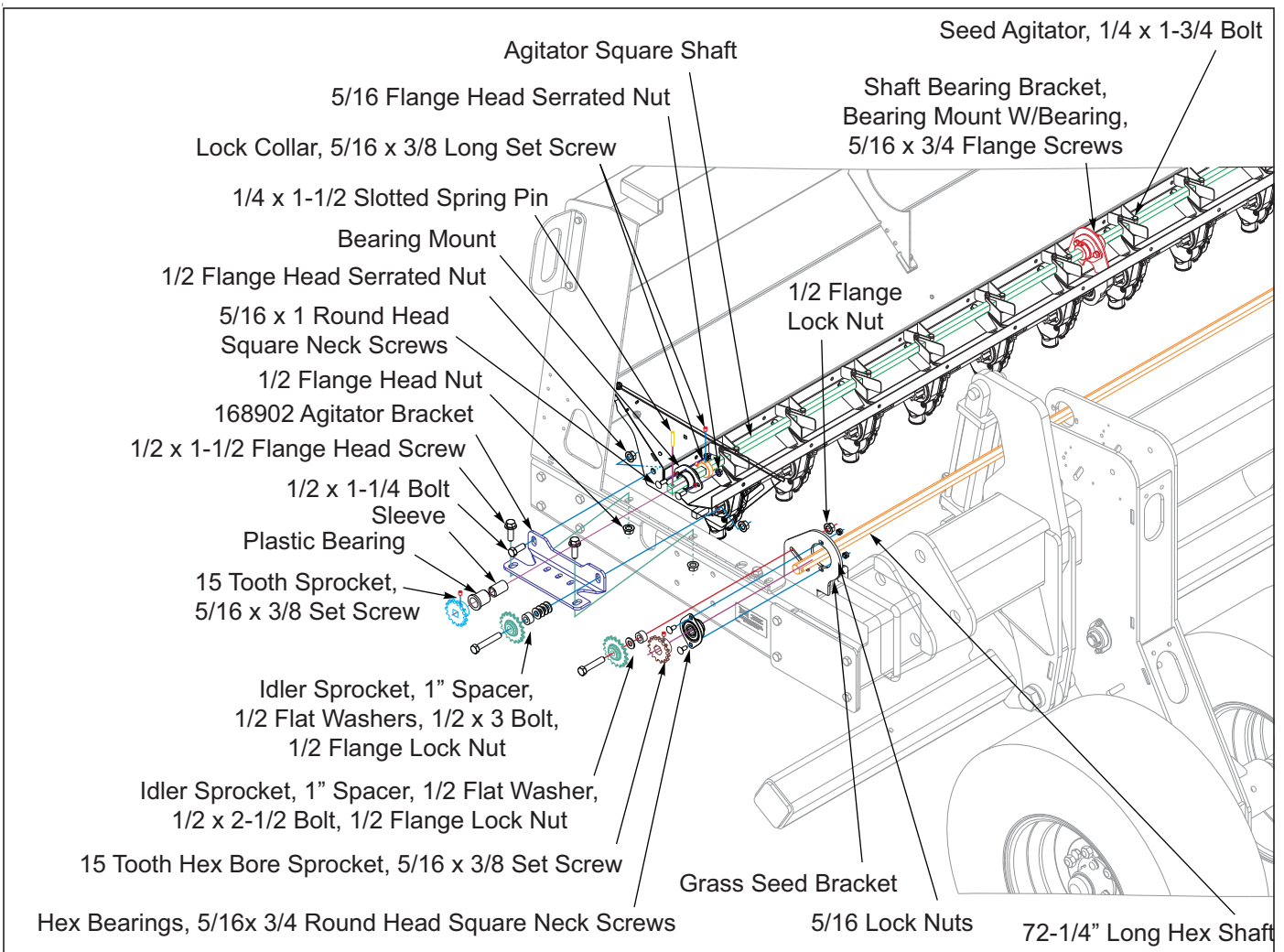

Figure 3-9: Right & Left Grass Seed Brackets

15. Locate and center the middle agitator bearing bracket between the center two seed meter openings. Mark and drill 11/32" holes in the seed meter bottom to secure the agitator bracket. Use 5/16 x 3/4 flange

screws and lock nuts to fasten the agitator bracket.

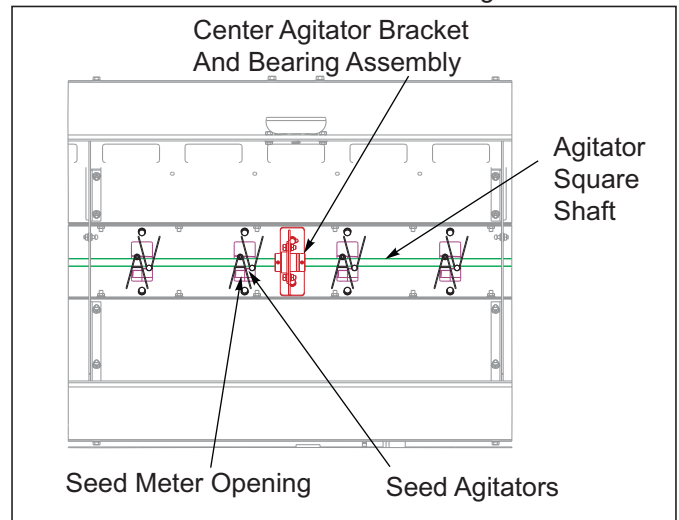

Figure 3-10: Middle Agitator Bracket

16. Route the drive chain around the agitator shaft and to the front hex drive shaft as shown **See Figure 3-11**. Adjust the chain tension with the front idler sprocket. Adjust the drive and idler sprockets as necessary to make sure the chain

and sprockets are in-line.
17. Verify that the agitator sprockets and chain is in-line. Rotate the drive wheel to verify that the drive chains are in-line and not binding.

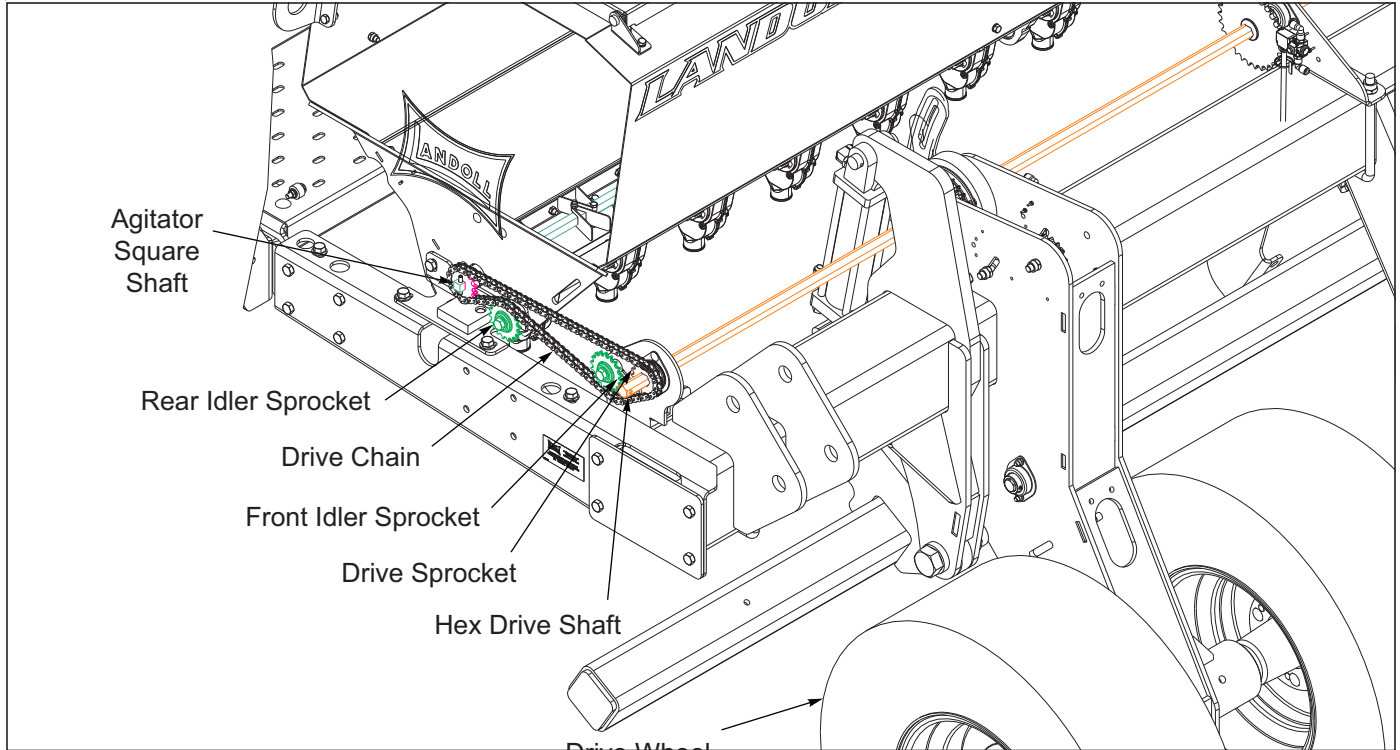

Figure 3-11: Agitator Drive Chain Assembly

18. install the new shorter seed level indicator rod **See Figure 3-12**. Otherwise the agitators will interfere with the indicator when the seed level is low.

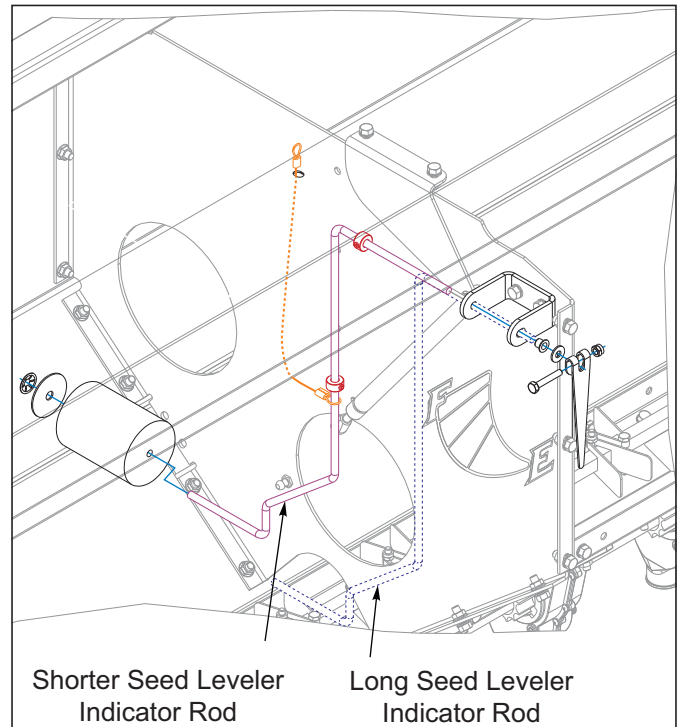

Figure 3-12: Seed Box Seed Level Rod Installation

5532 Hydraulic Marker Installation (Optional)

The 5532 grain drill may be equipped with optional hydraulic markers.

CAUTION

Please read the grain drill operator's manual before attempting to install, operate, or service the hydraulic markers.

WARNING

Do not attempt to lift heavy parts (such as the frame, wheel lift, and pull hitch) manually. Use a hoist or a forklift to move these parts into position.

DANGER

To prevent accidental lowering:

- All hydraulically elevated equipment must be locked out using the cylinder lockouts.
- Lower equipment to the ground while servicing or when it is idle.
- Failure to take measures to prevent accidental lowering may result in serious personal injury or death.

CAUTION

Be sure to bleed the hydraulic system of all air in lines after installation. Failure to bleed the system of all air can result in improper machine operation.

CAUTION

Marker blades are very sharp, use gloves when working around marker blades.

WARNING

Escaping hydraulic fluid can cause serious personnel injury. Relieve system pressure before repairing, adjusting, or disconnecting. Wear proper hand and eye protection when searching for leaks. Use cardboard instead of hands *See Figure 4-11* Keep all components (cylinders, hoses, fittings, etc.) in good repair.

DANGER

To prevent injury or death, stay clear of markers while folding/unfolding. Hydraulic failure can allow markers to raise or fall suddenly.

DANGER

To prevent injury or death from electrocution: stay away from power lines while transporting, folding, or unfolding markers. Electrocution can occur without direct contact of power lines.

1. Attach the grain drill to the tractor and unfold the drill on a large level area large enough to unfold the drill and markers.
2. Lower the openers to the ground to relieve any hydraulic pressure.
3. Locate the two unused bulkhead fitting holes on either side of the front of the hitch *See Figure 3-18*. Remove the hydraulic hose shield from that side of the hitch.
4. Using a long fish tape or wire, insert through the large opening in the side of the front hitch, thru the hitch, and out the opening in the rear of the hitch tube.
5. Attach the 90 degree ends of both marker hydraulic hoses to the fish tape and pull the two marker hoses through the hitch. The 90 degree ends will be at the front of the hitch. This will be 260" hoses for the 30' and 312" hoses for the 40' drill.
6. Pull the 90 degree ends through the side opening just enough to access the hose ends. Attach the solid end of the bulkhead fitting to each of the 90 degree ends, and tighten securely. Remove the bulkhead fitting lock nuts. Pull the hoses and bulkhead fittings back inside the hitch openings and insert the bulkhead fittings through the two open fitting holes. Install the lock nuts to the bulkhead fittings on the outside of the hitch to hold the fittings in place.

NOTE

It may be necessary to loosen the fittings and bulkhead fittings and shield on the opposite side of the hitch for clearance to insert the marker fittings into the mounting holes.

7. Assemble the 90 degree adapters to the ends of the bulkhead fittings. Connect the 96" hydraulic hoses to the 90 degree adapters.
8. Secure the marker hoses to the mount on the side of the telescoping hitch with a hose clamp and 3/8 x 3 hex bolt.
9. Reinstall the hydraulic hose shield.
10. Install the black hose handles to the front of the 96" hoses. Assemble the couplers to the hose handles.
11. Remove the two 1/2 x 3-1/2 hex mounting bolts attaching the 16-port aluminum manifold on the top rear of the hitch **See Figure 3-13**. Using the same bolts, attach the valve mount bracket to the 16-port manifold.

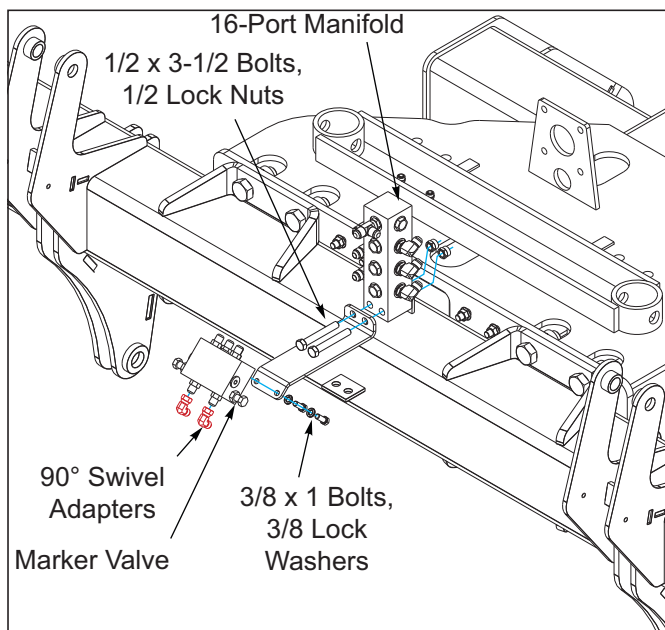

Figure 3-13: Marker Valve Installation

12. Bolt the marker valve to the valve mount bracket with 3/8 x 1 bolts and lock washers **See Figure 3-13**. Install the valve with the A & B ports pointing downward, and the C & R ports pointing upward.
13. Attach 90-degree swivel adapters to the A & B ports of the valve. Connect the marker hoses from the rear of the hitch to the 90-degree swivel adapters.
14. Remove the wing lock hook and latch and clamp bushings from the outer ends of both wings **See Figure 3-14** and **See Figure 3-16**.
15. Install the right and left marker mounts over the wing

lock hook & latch mounts using 1-1/4 x 8-1/2 bolts, u-bolts and lock nuts. Reinstall the wing lock hook and latch and clamp bushings when installing the marker mounts. Install the Danger- Electrocutation Hazard decal on the front of each marker mount above the fold hook and latch.

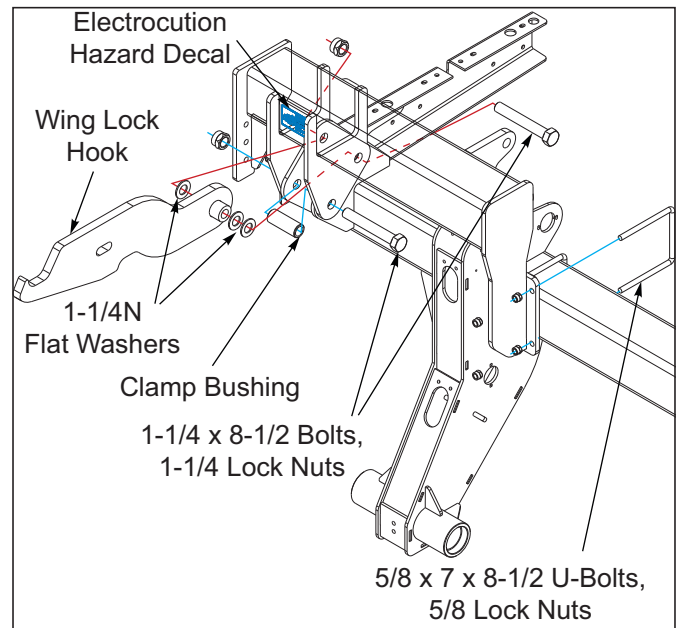

Figure 3-14: Marker Mounts Installation

16. Assemble the offset marker mounts to the marker mounts using 5/8 x 2-1/4 bolts and locknuts. Insert the bolts from the offset mounts towards the marker mounts.
17. Install the first arm weldment to the offset mount using double hole pivot pin and 1/4 x 2 cotter pins. Install grease zerks in each end of the first arm **See Figure 3-16**.
18. Connect the mid arm weldment to the first arm with 1-1/4x12 pin, 1-1/4 flat washers, and 1/4 x 2 cotter pins. Install a grease zerk in the outer end of the mid arm weldment **See Figure 3-17**.
19. Connect the base end of the marker cylinder the fold mount using a welded pin, 1-1/4 flat washers, and 1/4 x 2 cotter pins. Position the fold cylinders so the hydraulic ports face rearward. Connect the rod end of the fold cylinder to the slotted hole of the mid arm using pin washer weldment, 1-1/4 flat washers and 1/4 x 2 cotter pins. Install washers over the outside of the slotted holes **See Figure 3-16**.
20. Assemble the outer arm to the mid arm, using 7/8 x 11 pin and 1/4 x 1-1/4 cotter pins **See Figure 3-17**.
21. Install the rubber spacer to the outer arm using 3/8 x 1-3/4 screws, 3/8 flat washers, and 3/8 locknuts. Secure the spacer in place, but do not excessively tighten the spacer bolts.

22. Install the extension tube in the outer arm with the holes to the outer end and pointing upward. Secure the outer arm with a u-bolt and lock nuts.
23. Assemble the marker blade and hub assemblies to the outer arms using $\frac{1}{2}$ x 3-1/2 rd head sq neck screw, washers, lock washers, and nuts. See operating section for setting angle and operation.
24. Install the row marker linkage in the top of the outer arm with 5/8 x 3 screw and locknut.
25. Slide the chain cover over each row marker chain.
26. Attach one end of the marker chain to the row marker linkage with 3/8 x 2-1/2 screw, 5/8 x 1-7/8 spacer tube, flat washers, and lock nut.
27. Thread a 5/8 jam nut approximately half way onto the externally threaded yoke. Screw the internally threaded yoke onto the externally threaded yoke up to the nut.
28. Pin one end of the yoke assembly to the ear on the first arm. Connect the other end of the yoke assembly to the end of the row marker chain. Connect the chain to the yoke assembly to the shortest link possible. There should only be a slight amount of chain slack left for down flex of the marker arm. The adjustment may be fine-tuned with the yoke assembly. Tighten the locking jam nut on the yoke assembly to hold in place.
29. On 40' drills install the marker support mount to the front of the wing frame, using u-bolts and 5/8 locknuts, approximately 30" from the marker mount **See Figure 3-15** and **See Figure 3-16**. Attach the marker support arm to the front of the mount with u-bolts and 1/2" locknuts. The marker support stand should extend to approximately 48" above the top of the drill frame with the longest offset pointing forward. Install the rubber brace cushion to the top of the marker support stand using 5/16 x rd head sq neck screws, lock washers, and nuts.
30. Install a 90-degree adapter in the rod end of each marker cylinder **See Figure 3-18**.
31. Install a long straight adapter and a 90-degree swivel elbow in the base end of each marker cylinder.
32. Connect the wing hoses as shown from the marker valve to each of the marker cylinders. **Note: connect the "R" ports of the marker valve to the rod end of each marker cylinder. The "C" ports connect to the base end of the marker cylinders. Route the hoses from the marker valve along the existing wing hoses and secure with clamps and 3/8 bolts, flat washers, and lock nuts.**
33. Once assembled the hydraulic lines must be purged of air before attempting to fold/unfold the markers. To purge the marker system of air, unpin the rod end of both marker cylinders. Align or prop the marker cylinders so that the rod will not interfere with anything during its travel. Slowly engage the tractor hydraulics fully extending and retracting both marker cylinders. Repeat several times until the action of both cylinders is positive and immediately responsive. Do not loosen or crack any fittings Reconnect the rod end of both cylinders. **Note: the marker valve will only allow one side to operate at a time and alternate back and forth.**
34. When the system has been purged of air and cylinder rod ends reconnected, slowly engage the marker hydraulics and watch the markers fold/unfold. Watch the fold hoses carefully to make sure there is enough slack in the hoses and not catching on anything. Adjust the 40' marker stands if necessary to support the folded markers.
35. Attach a hose clamp to the left side of the hose holder plate on front of hitch and to rear frame plates using 3/8 x 3 bolt, 3/8 flat washer and 3/8 lock nut **See Figure 3-18**.
36. Check all screws, fittings, hoses, and pins to make sure connections are tight and secure.

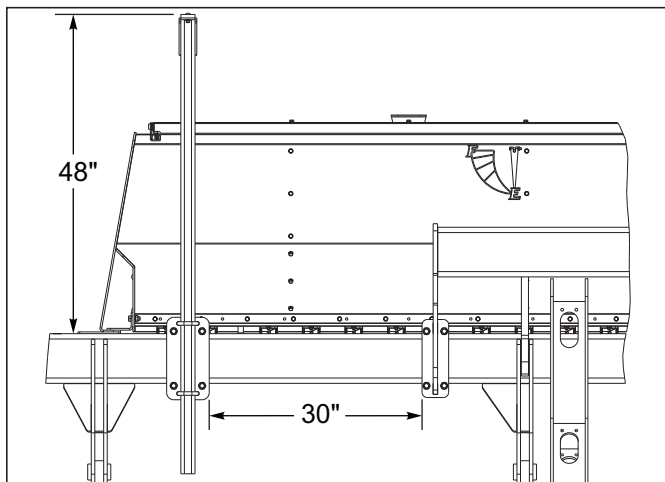

Figure 3-15: Marker Support Placement 5532-40'

TABLE OF CONTENTS

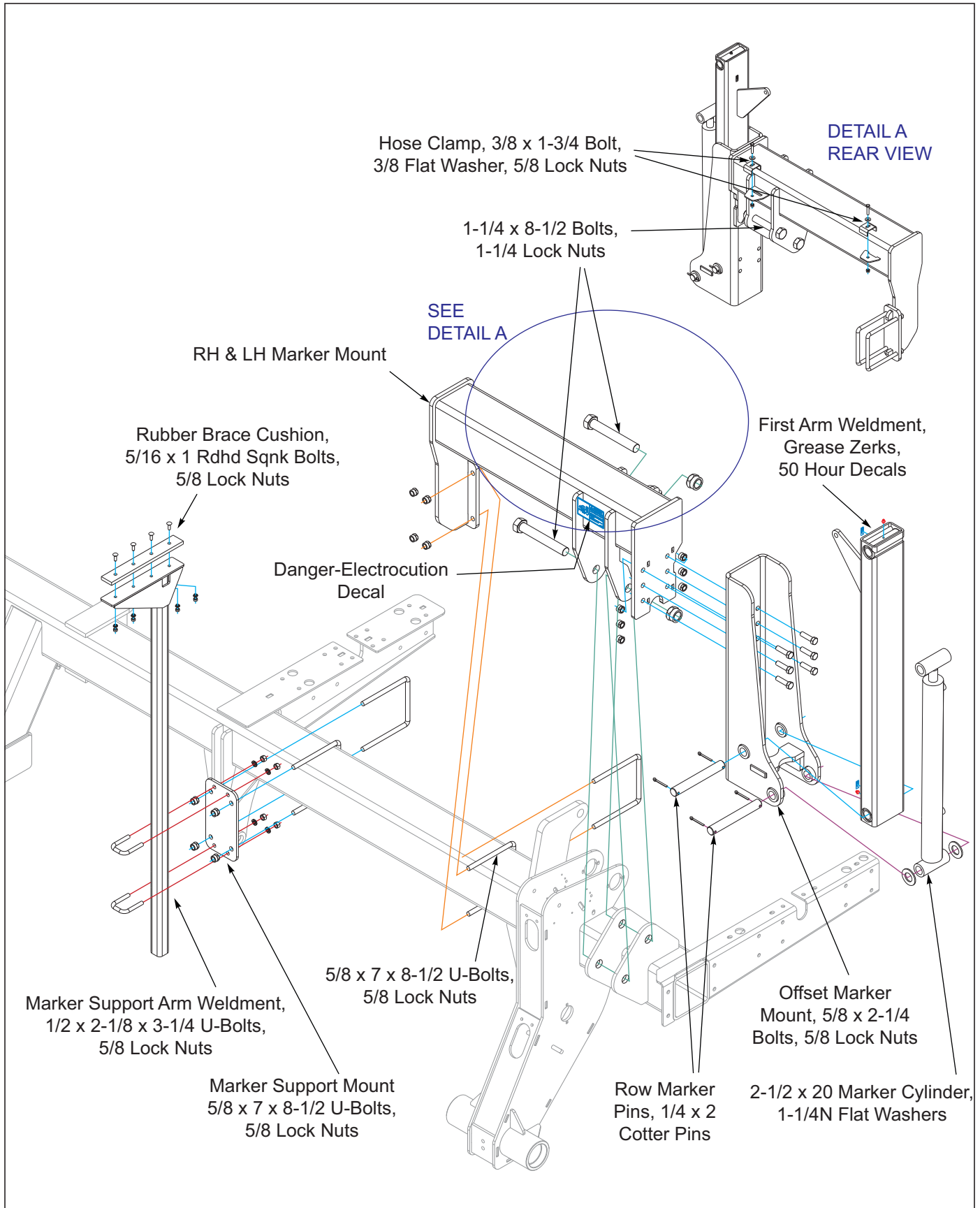

Figure 3-16: Marker Assembly (1 of 2)

TABLE OF CONTENTS

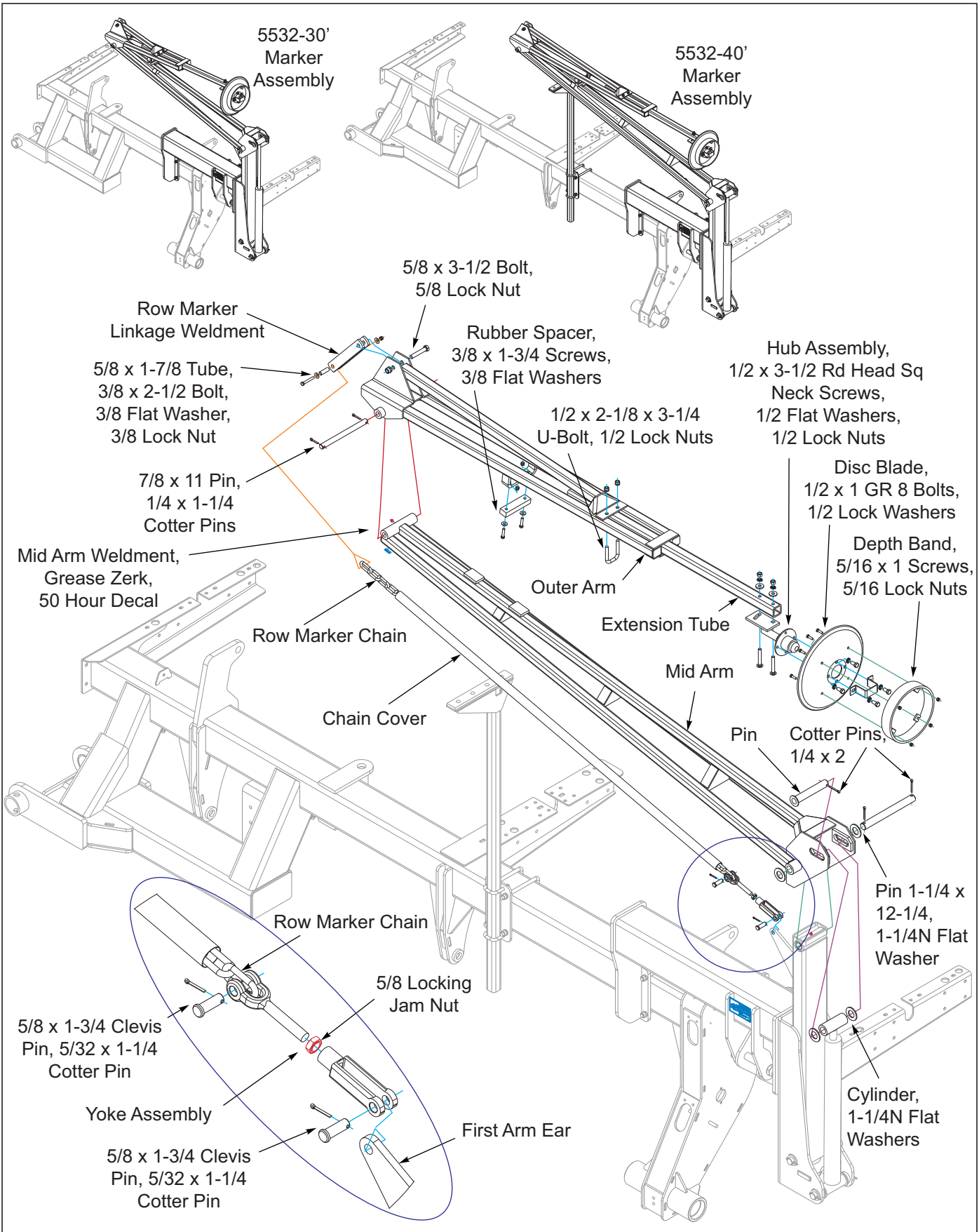

Figure 3-17: Marker Assembly (2 of 2)

TABLE OF CONTENTS

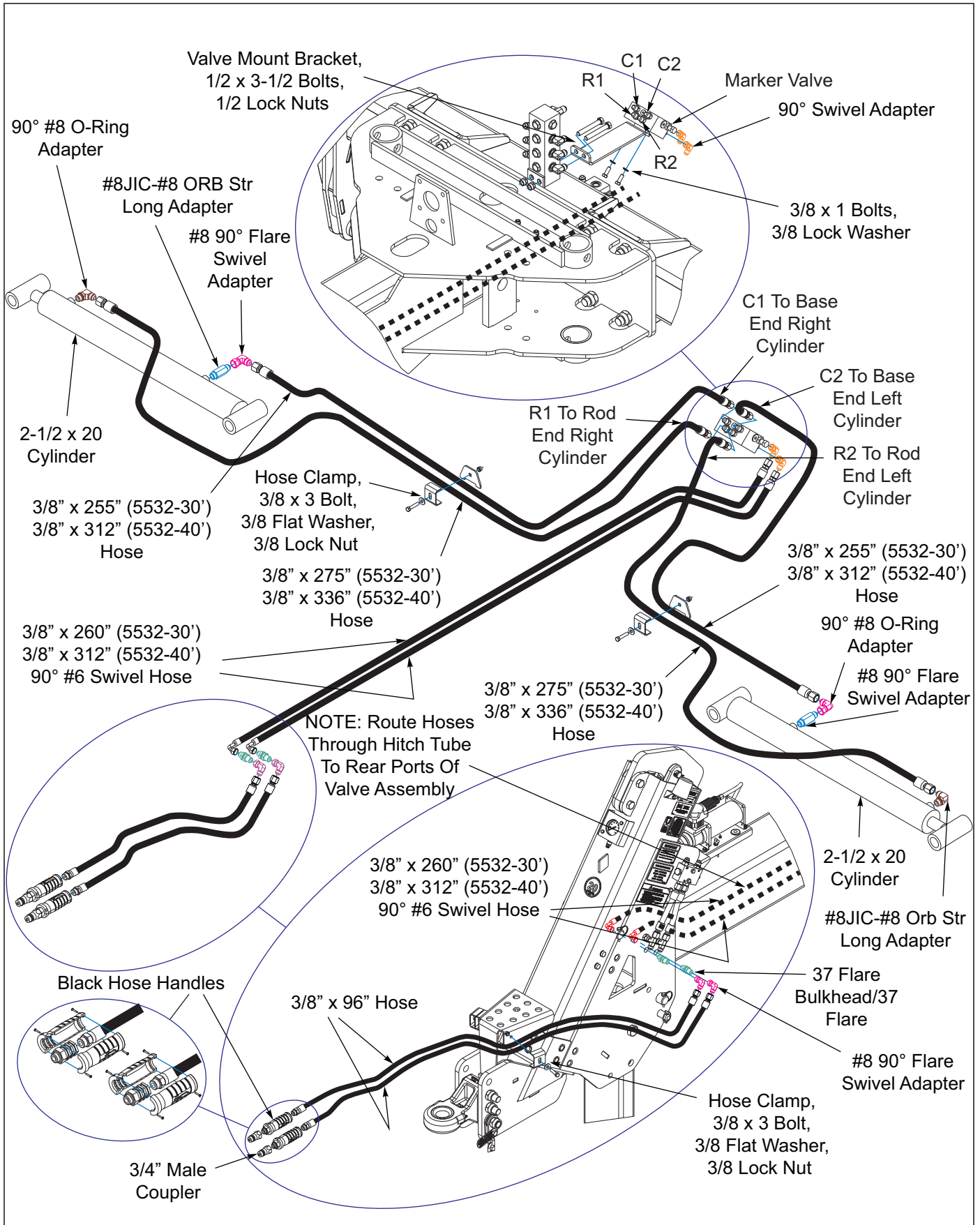

Figure 3-18: Marker Assembly Hydraulics

**DANGER**

Never allow anyone to ride on the 5532 Grain Drill at any time. Allowing a person to ride on the machine can inflict serious personal injury or death to that person.

**DANGER**

Install hitch cylinder and wing lock pins before transporting. Failure to lockout the cylinders can cause the unit to settle during transport which can result in serious injury or death and cause equipment damage.

**DANGER**

Opener blades are extremely sharp. Exercise extreme care when working on or near opener blades. Do not allow opener blades to roll over or fall onto any body part. Do not allow wrenches to slip when working near blades. Never push wrenches toward opener blades. Do not climb over machine above opener blades. Failure to stay clear of opener blade edges can cause serious personal injury or death.

**CAUTION**

When transporting farm implements on public roads, it is the responsibility of the operator to abide by state and local laws concerning wide loads, speed, safety emblems and safety lighting equipment. Drive at safe speeds, particularly when rounding corners, crossing rough ground or driving on hillsides, to prevent tipping the tractor.

**WARNING**

Lower elevated components or install cylinder lockouts and pins before servicing or when equipment is idle. Failure to take preventive measures against accidental lowering can result in serious personal injury.

**CAUTION**

Relieve system air pressure before attempting to adjust or service any air spring component. Make sure all components are in place and secure before charging the system.

**DANGER**

Keep all bystanders away from the machine when folding/unfolding, raising/lowering openers, and transporting.

**DANGER**

To prevent injury or death from electrocution: stay away from power lines while transporting, folding, or unfolding markers. Electrocution can occur without direct contact of power lines.

**DANGER**

Always lock the tractor drawbar in the center position when transporting the unit. Failure to do so can result in serious injury or death and cause damage to the machine.

5532 Operation Checklist

This section is a checklist for general operating procedures. Refer to individual sections for further details on safety, settings, and proper procedures.

Initial Checklist

1. Read and understand the operating manual and all Safety Information.
2. Adjust the hitch clevis height for the tractor used for planting.
3. Attach the grain drill to the tractor with proper locking hitch pin and safety chain.
4. Check all the tires for proper inflation and all lug nuts for proper torque.
5. Lubricate the drill at all points listed.
6. Check all bolts and fasteners to verify they are not loose.
7. Replace or repair any damaged or worn parts.
8. Inspect all hydraulic cylinders, fittings and hoses for leaks and repair before going to the field.
9. Check drive chains for wear and proper tension.
10. Check air system and verify system holds and maintains pressure. Locate and repair any leaking airlines, fittings, or air springs.
11. Clean seed boxes of any old seed or residue.
12. Verify all seed hoses are connected and not ripped, torn, or sagging.
13. Check opener blades for wear and proper pinch point.
14. Rotate drive wheels to verify all shafts and chains turn freely.
15. Turn on seed monitor and verify there are no errors.

Field Checklist

1. Check all hydraulic and electrical connections. Keep hoses and wires above hitch pin and free from 3PT hitch.
2. Turn on the air compressor and verify operation.
3. Raise the openers, then check and adjust system air pressure.
4. Adjust seed gate to desired setting and verify all gates are set the same.
5. Adjust seeding rate to the desired setting for all sections.
6. Adjust the seed drive setting to the same type for all sections.
7. Adjust the dry fertilizer drive to desired setting for all sections.
8. Adjust the small seed rate to the desired setting for all sections.
9. Calibrate the seed and fertilizer settings.
10. Adjust all press wheels to the desired settings for all sections.
11. Adjust monitor to desired settings and limits, width, spacing, acres, etc.

Field Operation

Never allow anyone to ride on the grain drill, stay clear of moving parts.

Raise the drill when turning. Avoid backing up to prevent plugging and equipment damage.

Stay away from power lines during operation when folding or unfolding the drill and markers. Electrocuting can occur without direct contact.

Do not transport the drill full of seed and fertilizer.

1. Stop the drill.
2. Raise the drill and remove hitch cylinder lock pin and wing lock pin.
3. Fully raise drill openers.
4. Completely lower drill and hitch.
5. Unfold drill on level area.
6. Raise drill hitch until indicator is centered in hitch window.
7. Fill the drill with desired seed and fertilizer and close all lids.
8. Begin planting, pull forward and lower the openers, fully extending the opener cylinders.
9. After pulling a short distance, stop the drill. Verify all openers are planting, seed depth and placement is correct, sufficient weight on the press wheels. Make any adjustments and resume planting.

Planting Completion

1. Stop the drill on a large level area.
2. Fold markers.
3. Raise the drill openers.
4. Completely lower the drill and hitch.
5. Fold the drill.
6. Fully raise the drill and hitch making sure the wings locks and main lift are latched.
7. Install hitch cylinder lock and wing lock pins.
8. Remove any unused seed and fertilizer from the drill after planting season.

Tractor Preparation

The Landoll 5532 Grain Drill is designed to be pulled by tractor equipped with a double lip or clevis type hitch. If your tractor is not equipped as such, you need to purchase the hitch from your local tractor dealer.

Before attaching the Grain Drill, prepare the tractor as follows:

1. Inflate the rear tractor tires equally and add ballast according to the tractor operator's manual.
2. Lock the tractor drawbar in the center position.

Grain Drill Preparation

1. Prior to operating the 5532 Grain Drill, read and understand the operator's manual and all decals.
2. Inspect the machine thoroughly for good operating condition.
3. Replace worn or missing parts.
4. When the machine is new, check the bolt tightness after a few hours of operation. Tighten any loose nuts or bolts. Check the lift wheel lug bolts daily.
5. Check the lift wheel tire inflation. Inflate all tires equally to avoid side draft. Follow the tire manufacturer's recommended pressures listed on the sidewall of the tires.
6. Lubricate the machine *See "Storage" on page 5-6. and Figure 5-4 on page 5-5.*
7. Check that all safety decals and reflectors are correctly located and legible. Replace if damaged.

Attaching Grain Drill To The Tractor



WARNING

The Grain Drill has positive and negative tongue weight depending on wing fold position. Use a locking-style hitch pin that is properly sized for the tractor drawbar and implement hitch.

1. Make sure the tractor drawbar is rated and adjusted properly for the weight of the drill hitch.
2. Measure the tractor drawbar and adjust the hitch clevis to the appropriate hitch mounting holes *See Figure 4-3.*
3. Carefully back the tractor into position. If the draw bar is too high or too low, attach the hydraulic hoses to the tractor. Slowly extend or retract the telescoping hitch until the hitch is in line with the tractor clevis.

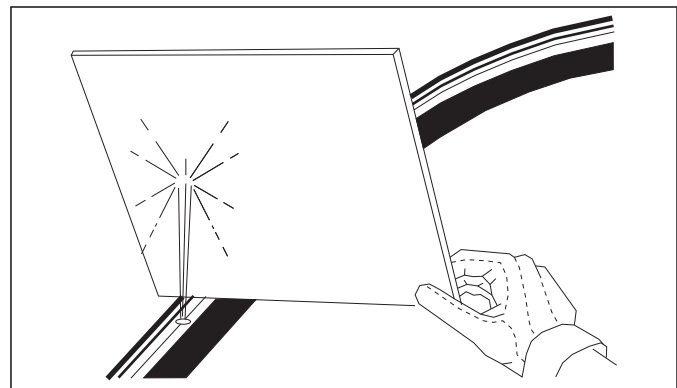

Figure 4-1: Hydraulic Leak Detection



WARNING

Escaping fluid under pressure can penetrate the skin causing serious personnel injury. Avoid the hazard by relieving system pressure before disconnecting hydraulic lines. Tighten all connections before applying pressure. Keep hands and body away from pinholes which eject fluid under high pressure. Wear protective gloves and safety glasses when working with hydraulics. Use a piece of cardboard or paper, not body parts to search/check for leaks *See Figure 4-1.* If an accident occurs, see a doctor immediately. Any fluid injected into the skin must be surgically removed within a few hours or gangrene may result.

4. Back the tractor into final position, and install the hitch pin. Use a locking style hitch pin that properly fits the tractor drawbar and implement hitch.
5. Connect the lift, fold, opener and optional marker hoses to the tractor.
6. Plug the safety lights into the seven-pin connector on the tractor.
7. Attach the safety chain *See Figure 4-6,* to the tractor manufacturer's recommended anchor. Allow enough slack for turning in both directions. The chain hook should latch securely to prevent it coming loose.
8. Fully raise the hitch and install the hitch cylinder lock pin.
9. Rotate the parking jack stand into storage position and pin in place.
10. Install the lock pin in the wing fold locks to prevent the wings from unlatching.

Hitch Cylinder and Wing Lock

1. Cylinder lock pins are provided to secure the Grain Drill in raised and folded positions. Do not rely totally on hydraulics when working beneath raised equipment.



WARNING

Install cylinder lock pins before attempting to service, adjust, or transport raised equipment.

2. To install the telescoping hitch cylinder pin lock, fully raise the main lift and hitch. Remove the pin from the storage position and install through the hole in the telescoping hitch *See Figure 4-2*. Leave the weight of the drill on the hydraulic system while transporting. The pin will prevent any uncontrolled dropping of the hitch.
3. After folding the drill and raising the hitch, install the wing lock pin in the wing fold lock over the top of the hitch *See Figure 4-2*. Rotate the handle counter clockwise to release the handle. Push the handle in to lock the wings, and pull the handle out to unlock the wings. Rotate the handle clockwise to secure the handle in the desired position. This will insure the fold locks do not come apart while transporting.

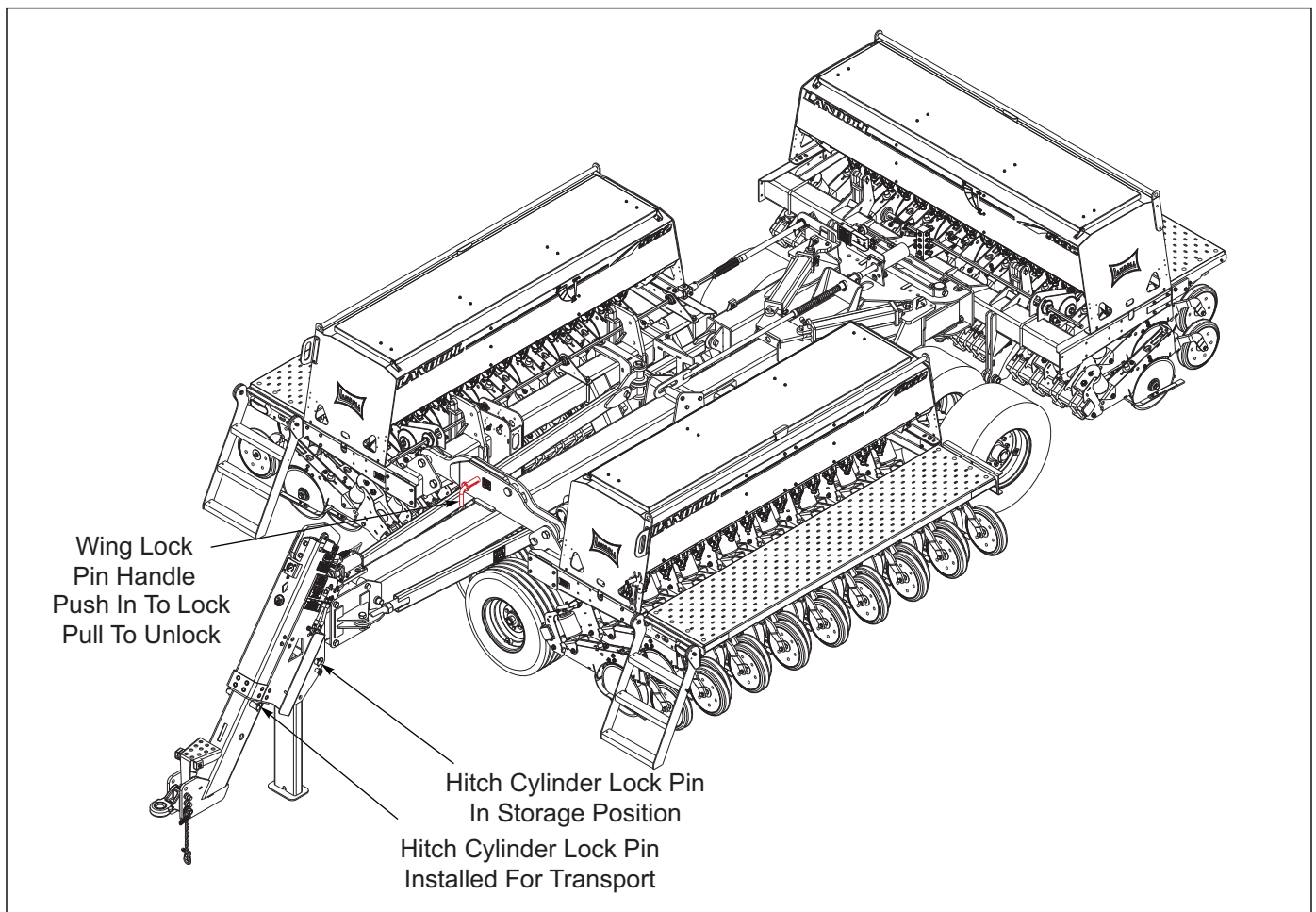

Figure 4-2: Hitch Cylinder and Wing Locks

Folding/Unfolding the Grain Drill

The Grain Drill is equipped with hydraulic cylinders to fold and unfold the drill from transport to field position. A combination of both the fold and lift hydraulics will be used to fold/unfold the drill.



DANGER

The Grain Drill should be folded/unfolded on a large level area large enough to accommodate the drill when unfolded. Be sure other people and pets are a safe distance away. Tractor should be stopped and not moving, with the engine at a slow idle.

1. Before folding/unfolding the drill, pin the drill hitch to the tractor drawbar **See “Attaching Grain Drill To The Tractor” on page 4-4.**



WARNING

The wings will generate negative tongue weight when the unit is unfolded causing the hitch to rise suddenly, possibly resulting in serious injury or death. Be sure the drill hitch and safety chain are securely attached to the tractor before unfolding the Grain Drill.

2. Connect the hydraulic hoses to the tractor remote.
3. When unfolding:
 - a. Rotate the parking jack stand into storage position and pin in place.
 - b. Fully raise the Grain Drill to relieve pressure on the main lift transport locks, and cylinder lock pins.
 - c. Remove hitch cylinder lock pin from telescoping hitch and wing fold lock and place in storage locations **See Figure 4-2.**
 - d. Fully raise the opener tool bars for maximum opener clearance.
 - e. Completely lower the Grain Drill hitch and main lift to the ground.
 - f. Slowly unfold the Grain Drill until the wing fold cylinders are fully extended.
 - g. Raise the Grain Drill hitch until the visual reference indicator is centered in the diamond-shaped hole at the front top of the hitch **See Figure 4-4.**

NOTE

If the hitch is raised past the center position, fully lower the hitch, and re-raise the front of the hitch. This will insure the wing brace locks are fully engaged before planting.

4. When folding:
 - a. Raise the opener tool bars for maximum opener clearance.
 - b. Fully lower the hitch.
 - c. Slowly engage the wing fold cylinders and fold the wings forward.
 - d. Fully raise hitch and main lift. Watch to make sure the wing locks have fully engaged as the hitch begins to raise.
 - e. Install cylinder lock pins in the telescoping hitch and wing lock to secure the Grain Drill **See Figure 4-2.**

Leveling the Hitch Clevis

1. The hitch clevis height should be adjusted to match the drawbar height of the tractor. This will allow the telescoping hitch to operate through its most efficient range and level throughout the field **See Figure 4-3.**
2. On a level surface, measure from the ground to the top side of the tractor drawbar. For drawbar heights 18” or lower use the lower hitch clevis holes. For drawbars 20” tall use the middle hitch clevis holes, and for 22” or greater use the top mounting holes.
3. To change the hitch clevis mounting holes, the drill should be folded and unhitched from the tractor. This will remove any hitch weight from the hitch clevis.

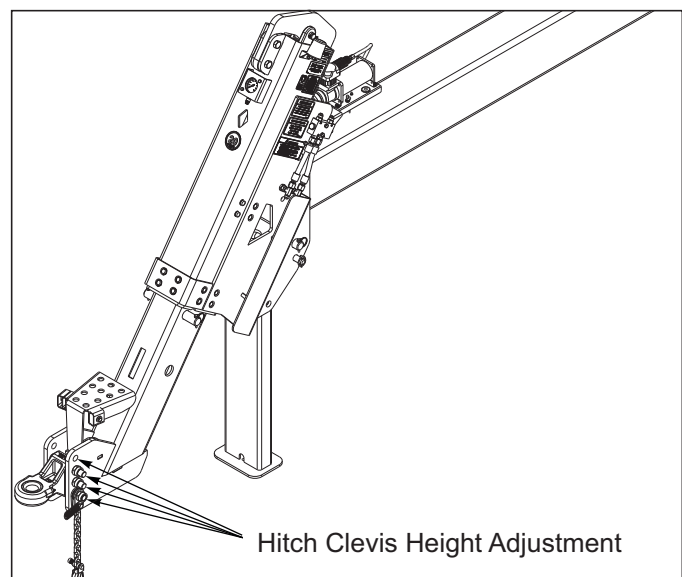

Figure 4-3: Hitch Clevis Height

Leveling the Hitch

1. When unfolding the Grain Drill the hitch is lowered to its lowest point to allow the wing fold locks to unhook and clear. Before starting to plant, the hitch should be leveled to insure proper opener depth and full opener travel.
2. Make sure the hitch clevis is adjusted for the proper tractor drawbar height *See Figure 4-3*.
3. Use the diamond shaped hole at the front of the hitch as a guide to level the hitch for planting operations *See Figure 4-4*. The wear pad (inside the hitch tube) will be visible from the tractor seat as it slides by the reference hole. When the reference line on the wear pad is centered in the diamond shaped hole, the hitch should be level. Do not insert any objects in the reference holes as the wear pad slides over these holes and could damage the hitch.

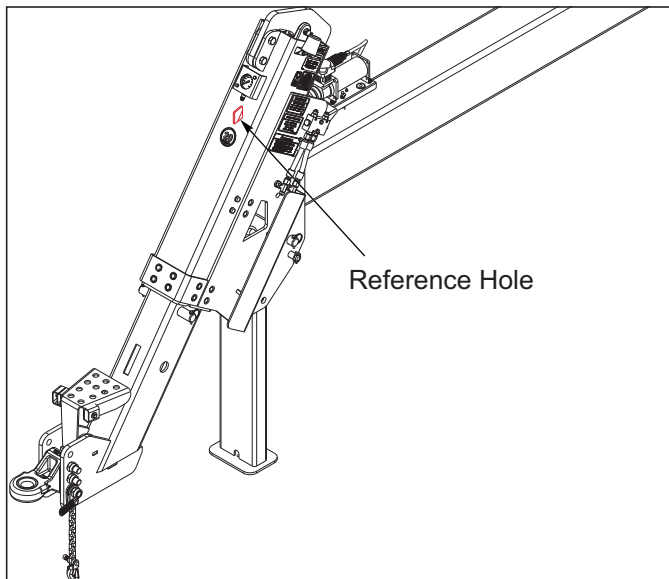

Figure 4-4: Leveling the Hitch

Transporting the Grain Drill

1. Check and follow all federal, state, and local requirements before transporting the Grain Drill.
2. The Grain Drill should be transported only by a tractor required for field operation. The implement weight should not exceed more than 1.5 times the tractor weight. Unless noted on the implement, maximum transport speed is 20 mph for the implement and is designated on the speed identification symbol (SIS) located on the front and rear of the implement *See Figure 4-5*.

⚠ CAUTION

Excessive speed may result in loss of control of the tractor and implement, reduced braking, or failure of the implement tires or structure. Do not exceed the implement maximum specified ground speed regardless of the capability of the maximum tractor speed.

3. When towing equipment in combination, the maximum equipment ground speed shall be limited to the lowest specified ground speed of any of the towed implements.
4. Maximum transport speed shall be the lesser of travel speed specified in the operators manual, speed identification symbol, information sign of towed implement, or limit of road condition.

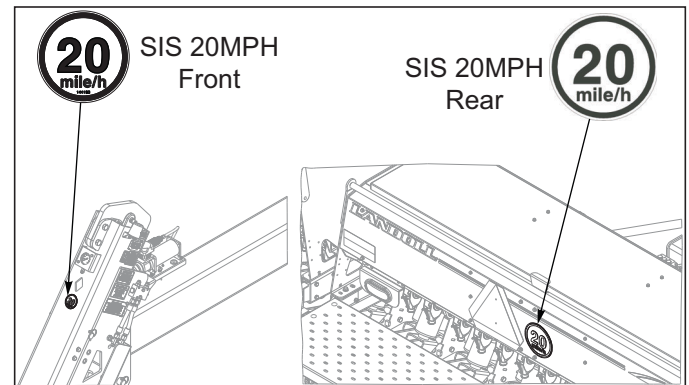

Figure 4-5: SIS 20MPH Decal

5. Slow down when driving on rough roads. Reduce speed when turning, or on curves and slopes to avoid tipping. Equipment altered other than the place of manufacture may reduce the maximum transport speed. Additional weight, added tanks, markers, harrow attachments, etc. may reduce the implements carrying capabilities.

6. A safety chain is provided with the implement to insure safe transport.
 - a. The safety chain should have a tensile strength equal to or greater than the gross weight of the implement. The chain is attached to the lower hitch clevis hole with two flat washers between the clamp plates to assure a tight connection. Always use a 1" diameter Grade 8 bolt for this connection.
 - b. Attach the safety chain to the tractor drawbar *See Figure 4-6* Provide only enough slack in the chain for turning. Do not use an intermediate chain support as the attaching point for the chain on the tractor. Refer to the tractor operator's manual for proper safety chain attachment. The chain hook should latch securely to prevent it from coming loose. Do not pull the implement by the safety chain.

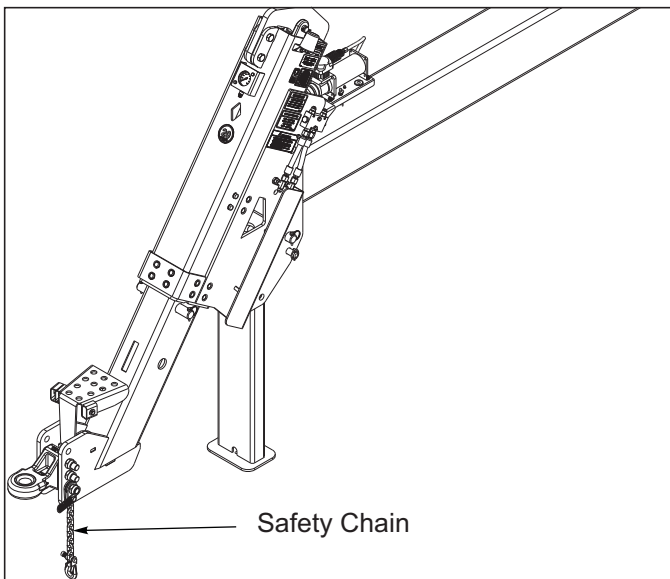

Figure 4-6: Safety Chain

- c. When unhitching from the tractor attach the hook end of the chain to a free link close to the hitch clevis for storage. This will keep the hook off the ground, reducing corrosion, and keep the hook functioning properly.
 - d. Regularly inspect the safety chain for worn, stretched, or broken links and ends. Replace the safety chain if it is damaged or deformed in any way.
7. Before transporting:
 - a. Know the height and width of the implement being towed. Markers, tanks, attachments, etc. can increase the height and width of the implement.



DANGER

Stay away from power lines when transporting, extending or folding implement. Electrocutation can occur without direct contact.

- b. Check to see that the tractor drawbar is rated to carry the weight of the Grain Drill hitch.
- c. Use a locking style hitch pin that properly fits the holes in the tractor drawbar and implement hitch.
- d. Attach safety chain.
- e. Plug in the safety lights to the tractor seven-pin connector.
- f. Fully raise the Grain Drill lift, hitch, and openers.
- g. Make sure all cylinder and wing lock pins are installed.



WARNING

Failure to use cylinder lock pins during transport may result in permanent equipment damage, serious injury, or death.

- h. Raise the implement parking jack stand.
- i. Check all tires for proper inflation, and that lug nuts are properly torqued.
- j. Verify that all warnings lights, SMV sign, reflectors, and safety decals are clearly visible and functioning properly.
- k. Transport during daylight hours whenever possible. Always use flashing warning lights, except where such use is prohibited by law. Make sure lights, reflectors and SMV emblem are clearly visible and operating. Remove any obstructions such as dirt, mud, stalks or residue that restricts view before transporting.
- l. Do NOT transport the drill with seed or fertilizer in the box.



CAUTION

Do not transport the Grain Drill with seed or fertilizer in the boxes. Seed, fertilizer, additional weight, markers, etc. can quickly exceed the carrying capabilities of the drill hitch and tractor drawbar.

- m. Do not operate any implement hydraulic functions while transporting.

Compressor Operation

1. The 5532 drill is equipped with a heavy-duty electric air compressor **See Figure 4-7** to charge and adjust the pressure in the opener air springs.
2. Power is supplied to the air compressor through power cable with a convenience plug to the tractor. The tractor should be equipped with a minimum 30 amp connection and operate only when the tractor switch is on to prevent the compressor from running down the tractor battery. It is recommended that the tractor be running while operating the compressor to insure full system voltage to the compressor. A toggle switch is located next to the compressor to turn the compressor on and off.

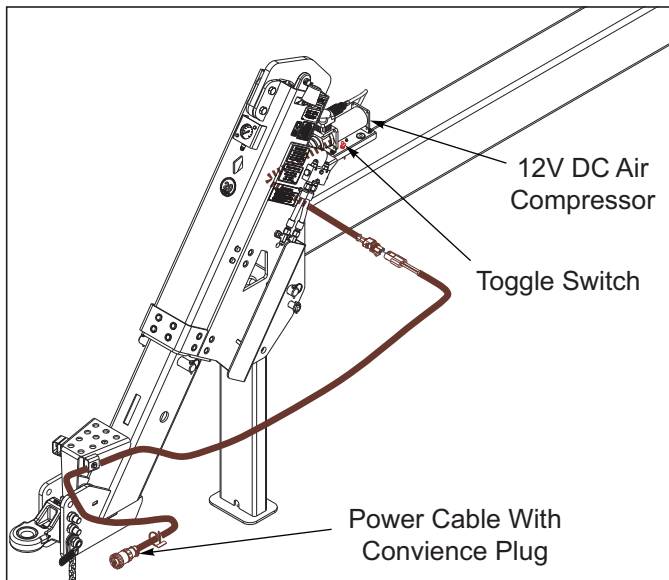

Figure 4-7: Air Compressor Connection

3. The drill compressor will operate much like a regular air compressor. Plug the power cable into the tractor and turn the compressor switch on. The compressor will charge the entire system and fill the main air tank in the center opener tool bar. A pressure switch **See Figure 4-8** will automatically turn the compressor off when the system has reached full pressure. Leave the compressor on while planting. This will ensure the air system is fully charged.

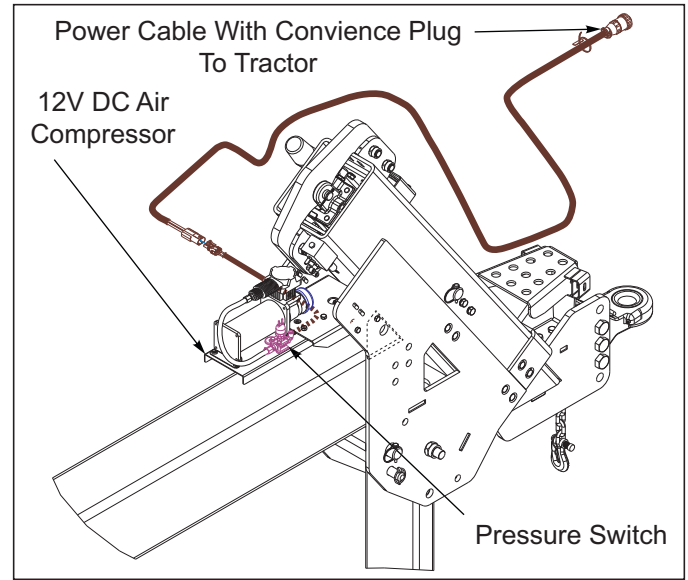

Figure 4-8: Air Compressor Pressure Switch

4. The air compressor is designed for oilless operation. There are no fluid levels to check or maintain. The compressor is equipped with a replaceable air filter. Service the filter regularly and replace each season with a new filter. Be sure to install the filter cover with intake pointing downward to prevent collecting dust and water.

Opener Air Pressure

1. Air to the openers is supplied by the drill air compressor *See Figure 4-10*. System air pressure is adjusted at the center frame *See Figure 4-9* with the pressure regulator. Opener operating air pressure is read at the gauge located on the air manifold on front of hitch.
2. Regulated system air pressure is delivered equally to all sections when the openers are in the raised position. A solenoid valve locks the air in each section when the sections are lowered in the planting position. This prevents the transfer of air between sections and even planting pressure across the drill.
3. Power is supplied to the air solenoids through the seven-pin connector to the tractor. Tractor must be on and connector in good working order to operate the air solenoids.
4. When making regulator adjustments to the opener system air pressure, fully raise the openers so there is no load on the openers. This will allow sections to fill evenly. Large pressure adjustments may take several minutes for the system to equalize.
5. The air system pressure on the Grain Drill can safely operate in a range from 15 psi to 100 psi. A opener pressure gauge is located on the center frame and front of hitch to monitor air pressure. It is normal for the opener air pressure to vary while working in the field. As the openers raise and lower over ground conditions, so will the opener pressure vary.

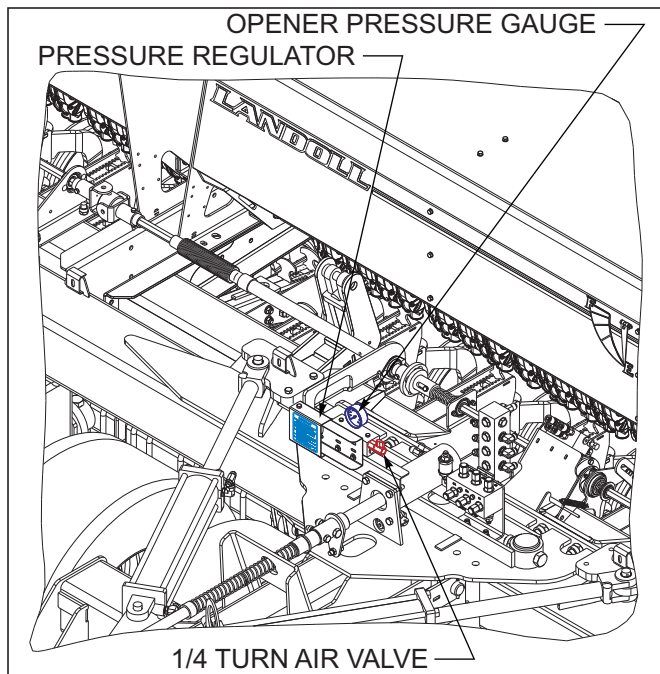

Figure 4-9: Air System Pressure

6. Do not at any time operate the air pressure below 15 psi. The air springs must maintain a minimum air

pressure for proper inflation. Too low of pressure will cause the air springs to rub internally and lead to failure.

7. System pressure should not exceed 100 psi. This is the maximum recommended working pressure the air springs are rated for. This will provide maximum down pressure for the row units. A system relief valve *See Figure 4-9* is installed at the front of the hitch to protect the system from excessive pressure. Do not remove or adjust the relief valve or damage to the air system may occur.
8. A schrader valve is located on the air manifold at the front of the drill *See Figure 4-10*. This allows air to be added to the system from an external air source (shop air). This is helpful when initially charging the air system, or when making large changes in system pressure.

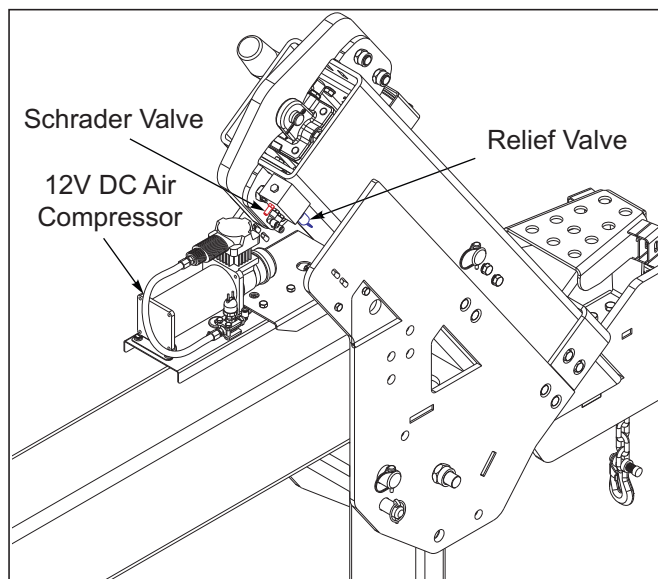

Figure 4-10: Schrader/Relief Valve

NOTE

The regulated air supply will compress in the air springs when the drill is lowered in the ground to working position. Thus the true opener gauge air pressure will always be greater than the regulated air setting by approximately 10-15 psi.

9. **To increase opener air pressure** – raise the openers out of the ground. With the tractor engine running, turn on the air compressor on the drill hitch. Open the regulator cover on the center frame, and turn the outer dial of the regulator to the desired higher pressure setting. Close the regulator cover, and allow the system to equalize. Lower the drill openers and plant a short distance, then check the opener pressure at the gauge on the opener manifold or front of hitch.

NOTE

It may take several minutes for the air to fill and equalize when making large adjustments.

- 10. To decrease opener air pressure** – raise the openers out of the ground. With the tractor engine running, turn on the air compressor. Open the regulator cover and turn the outer dial of the regulator to the desired lower pressure setting. Open the 1/4 turn air valve on the air manifold to bleed off excess opener air. Continue to bleed off air pressure until the air pressure gauge drops slightly below the regulator setting, then close the 1/4 turn valve. Close the regulator cover. Allow the system to equalize, lower the drill openers, and plant a short distance.
- 11. Initial settings** – When beginning planting operations, use an opener air pressure of 20-50 psi for light or sandy soils, 40-60 psi for medium or conventional tilled soils, and 70-100 psi for heavy and no-till planting. These are initial settings. Operator must verify seed placement and adjust air system pressure as required.

NOTE

Excessive air pressure can raise the drill out of the ground, particularly with low seed levels in the seed box.

NOTE

This procedure is for a normal operating air system. If any air leaks have developed in the drill section(s), they should be repaired immediately to insure equal consistent planting depths.

Maintenance

- Fully raise the openers and relieve air system pressure before attempting to adjust or service any air spring. To relieve air system pressure turn off the air

compressor switch and open the 1/4 air valve at the air manifold on the center frame of the drill to relieve all system air pressure. When system pressure is relieved, fully lower openers to prevent any accidental lowering while servicing. Do not pressurize the air system unless all row unit components are in place. Fully raise the openers before charging. When system pressure is relieved, fully lower openers to prevent any accidental lowering while servicing. When charging the system, verify that all air springs are filling properly. If the air spring buckles or rolls off to the side, relieve system pressure, and work or roll the air spring over the lower piston by hand. Slowly begin charging the system and verify proper filling.



CAUTION

Relieve system air pressure before attempting to adjust or service any air spring component. Make sure all components are in place and secure before charging the system.

Openers – Hydraulic Operation

- The Grain Drill openers are raised and lowered through a hydraulic lift system. Fully retract all cylinders to raise the openers. Likewise fully extend all cylinders to lower the openers. The cylinders must be fully extended to insure consistent planting depth and engage seed drive clutches. Do not operate the opener hydraulics in the “float” position.
- Raise the openers when transporting.
- During planting operation, always raise the openers before turning. Failure to raise the openers while turning can generate enormous side loading which could damage the openers.
- Never back up the Grain Drill with the openers in the ground. This can plug and possibly damage the openers.

Opener Bar Cylinder Lockout

1. The opener bars on the grain drill use a hydraulic lock valve to hold the openers in the raised and lowered position in normal operations.
2. For service, maintenance, or extended storage, cylinder lockout pins are provided at each opener cylinder to hold the openers in the raised position. To install the cylinder lock out pins, fully raise the openers and insert the lock out pin in the Lock position for each cylinder. This will mechanically lock the openers and prevent settling. Installing the cylinder lock out pins during long periods of storage will prevent the openers from settling and stretching out the seed hoses.

DANGER

- All hydraulically elevated equipment must be locked out using the cylinder lockouts.
- Or lower equipment to the ground while servicing or when idle.
- Failure to take measures to prevent accidental lowering may result in serious personal injury or death.

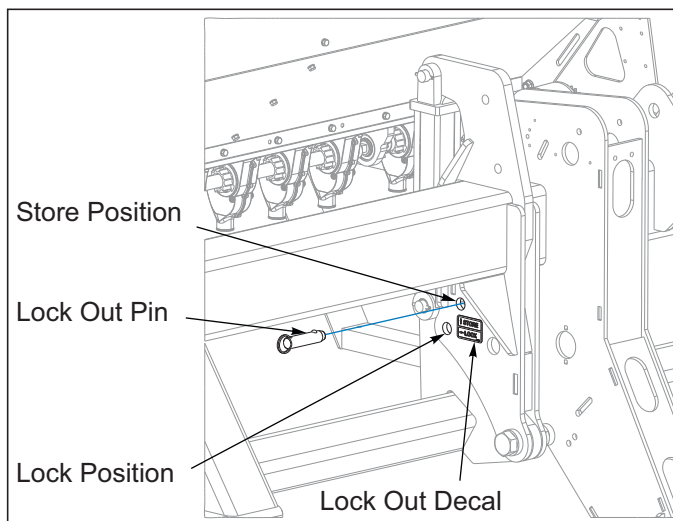



Figure 4-11: Opener Bar Cylinder Lockout

Hydraulic Lift System

The Grain Drill is equipped with a hydraulic lift system to raise and lower the unit from transport to planting position.

WARNING

Escaping hydraulic fluid can cause serious personnel injury. Relieve system pressure before repairing, adjusting, or disconnecting. Wear proper hand and eye protection when searching for leaks. Use cardboard instead of hands *See Figure 4-12.* Keep all components (cylinders, hoses, fittings, etc.) in good repair.

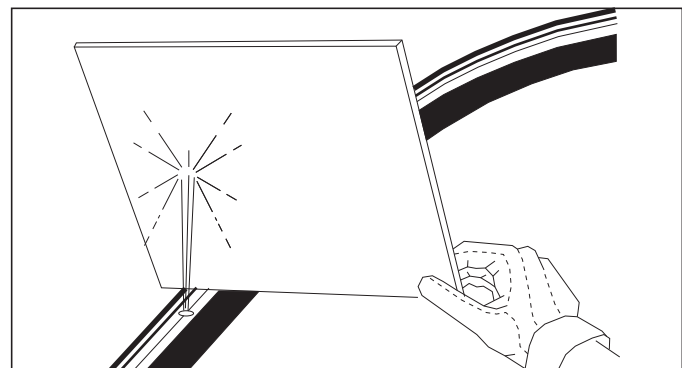

Figure 4-12: Hydraulic Leak Detection

1. The hydraulic lift system contains cylinders plumbed together.
2. The main lift cylinders and telescoping hitch are connected together on the same hydraulic circuit. Before transporting make sure both lift cylinders and hitch cylinders are fully extended for maximum transport height. Fully lower lift and hitch cylinders when folding/unfolding for clearance of the wing fold lock arms.
3. Before planting slowly raise the front hitch until the drill is level front-to-rear. The weight of the drill on the main lift will allow the front hitch to raise first.

NOTE

If the hitch is raised past the center position, fully lower the hitch, and re-raise the front of the hitch. This will insure the wing brace locks are fully engaged before planting.

4. The main lift is equipped with an automatic lock, that engages when the units is folded and fully raised. Verify that the locks are engaged before attempting to adjust, service, or work beneath the raised Grain Drill. The telescoping hitch is secured by a locking pin *See "Hitch Cylinder and Wing Lock" on page 4-5.*

Loup Drill Monitor Operation

1. The 5532 Grain Drill can be equipped with a Loup Mini or Elite drill monitor. The drill monitor will monitor population from two sensors on each box, seed box levels on the center and outer two seed boxes, as well as acres planted.
2. Population readings are 95% accurate for soybeans. When planting smaller seeds the population accuracy will be reduced. This does however give you a reliable indication that all sections are planting. The monitor may be adjusted to set high/low population alarms. Do not use the monitor to calibrate the seeding population. To calibrate the drill either by weight or seed count, see ***“Seed Rate Calibration” on page 4-18.***
3. Bin level sensors are installed in the center seed box, and the outer end of the outer most wing seed box. When the sensor is submerged in seed, no alarm will sound. As the seed level falls below the sensor eye, an alarm will be indicated on the drill monitor. The bin level sensor is mounted to an adjustable bracket. The bracket may be raised or lowered to the desired level in the seed box.
4. The drill monitor will also monitor field and total acres.
5. Pulses are preset for the drill monitor. Initially the pulses are set at 68. The pulse setting may vary depending on the conditions the drill is planting in. Worked or loose sandy soils will have a different setting than firm no till conditions. For greater accuracy on the pulse setting, calibrate the drill monitor in the desired working conditions. This is done by driving a known distance (400 ft) and recording the number of pulses in that distance. Refer to the Loup manual for instructions.
6. The drill monitor is operated on a 12-volt dc negative ground system. The monitor may be connected using the existing connection, or may be hard-wired to the appropriate connections. Connect the red wire to a positive terminal that is on when the tractor switch is on. Connect the black wire to a chassis ground on the tractor maintaining good metal-to-metal contact.
7. The signal cable attaches to the monitor and connects to the drill. The cable may be plugged/unplugged at the front of the drill hitch when hooking/unhooking the drill. This allows the monitor to stay in the tractor if so desired.
8. For service or setup questions, please refer to the Loup Drill Monitor manual, or contact Loup Electronics:

Loup Electronics Inc.
2960 N. 38th Street
Lincoln, NE 68504
877-489-LOUP(5687)
info@loupelectronics.com

Seed Meter Gate Adjustment

The seed meter has an adjustable seed gate to accommodate various seed sizes for planting. The seed gate is adjusted by the handle on the outside of each seed meter.

1. Use the top seed gate position when planting small seeds such as alfalfa, barley, rice, or wheat **See Figure 4-13.**

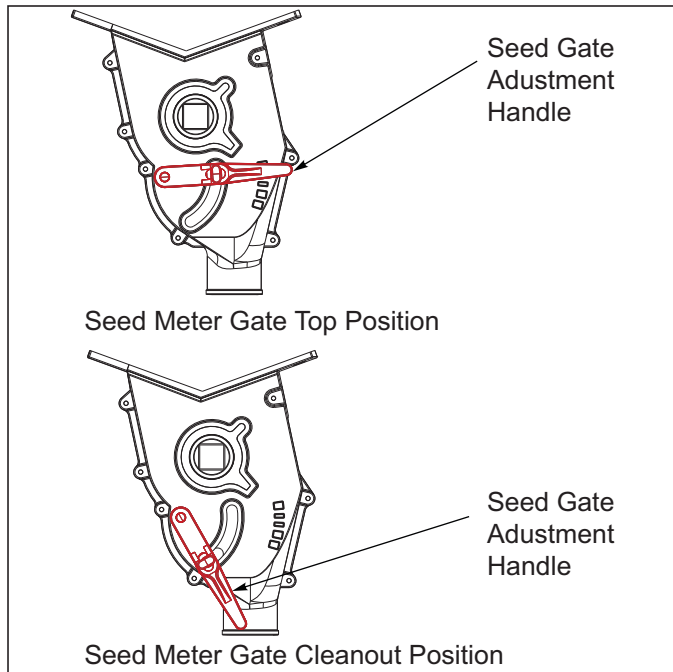

Figure 4-13: Seed Meter Gate Adjustment

2. The second seed gate position is for peas, small soybeans, etc. If excess cracking occurs, move the handle to the third position.
3. Use the third seed gate position for large peas, large soybeans, etc.
4. A fourth notch is for extremely large seeds such as garbanzo beans.

NOTE

Before filling the drill and planting, make sure all seed gate settings are the same for all meters.

5. The seed gate may also be completely lowered to clean out the meter and seed box **See Figure 4-13.** Fully open all seed meter gates at the end of planting season to clean out any remaining seed.

NOTE

Do not attempt to fully open the seed meter gate unless you are ready to empty the seed box. Once the gate is open, it may be difficult to close the seed meter gate until the seed box is empty.

Seed Rate Adjustment

1. Wrenches are provided to adjust the seed rate. They are stored on outside end of LH seed box **See Figure 4-14.**

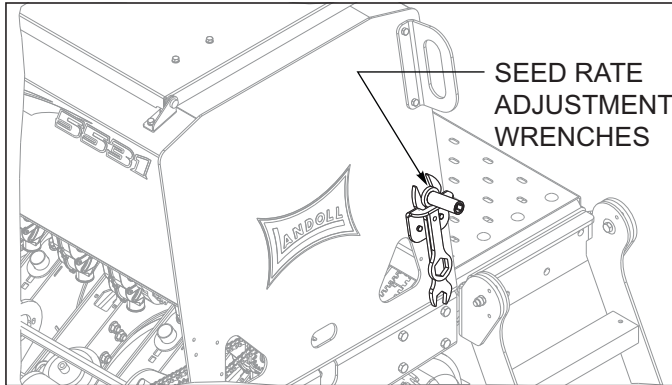

Figure 4-14: Wrench Storage Position

2. The seeding rate is adjusted for each section with the threaded seed rate adjustment at one end of each drill section. The end seed meter next to the adjustment has an indicating scale for reference. Read the scale along the **OUTSIDE EDGE** of the seed meter to determine the setting. The seeding rate should be set the same for all sections **See Figure 4-16.**
 - a. To set the seeding rate, first determine from the seed rate chart the meter opening for the desired seed rate. The seed rate chart is located inside the lid of the center seed box **See Figure 4-17.**
 - b. Loosen the locking nut on the square seed shaft

with the adjustment wrench **See Figure 4-15.**

- c. Using the seed rate adjustment wrench, insert the socket through the hole in the end box support to the hex-head adjustment bushing. Turn the hex-head adjustment bushing in or out, until the desired rate setting is obtained along the **OUTSIDE EDGE** of the seed meter.

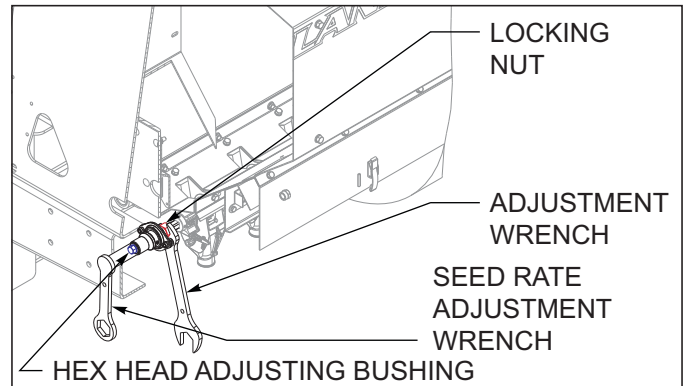

Figure 4-15: Wrench Adjustment Position

- d. Re-tighten the locking nut against end bushing to secure the seed rate setting, not seed meter.

NOTE

Do not force the seed meter shaft, damage will occur. The meter will not be able to fully close if there is seed in the box. Lube/oil the square seed shaft so that it will easily slide through the support bearing while adjusting.

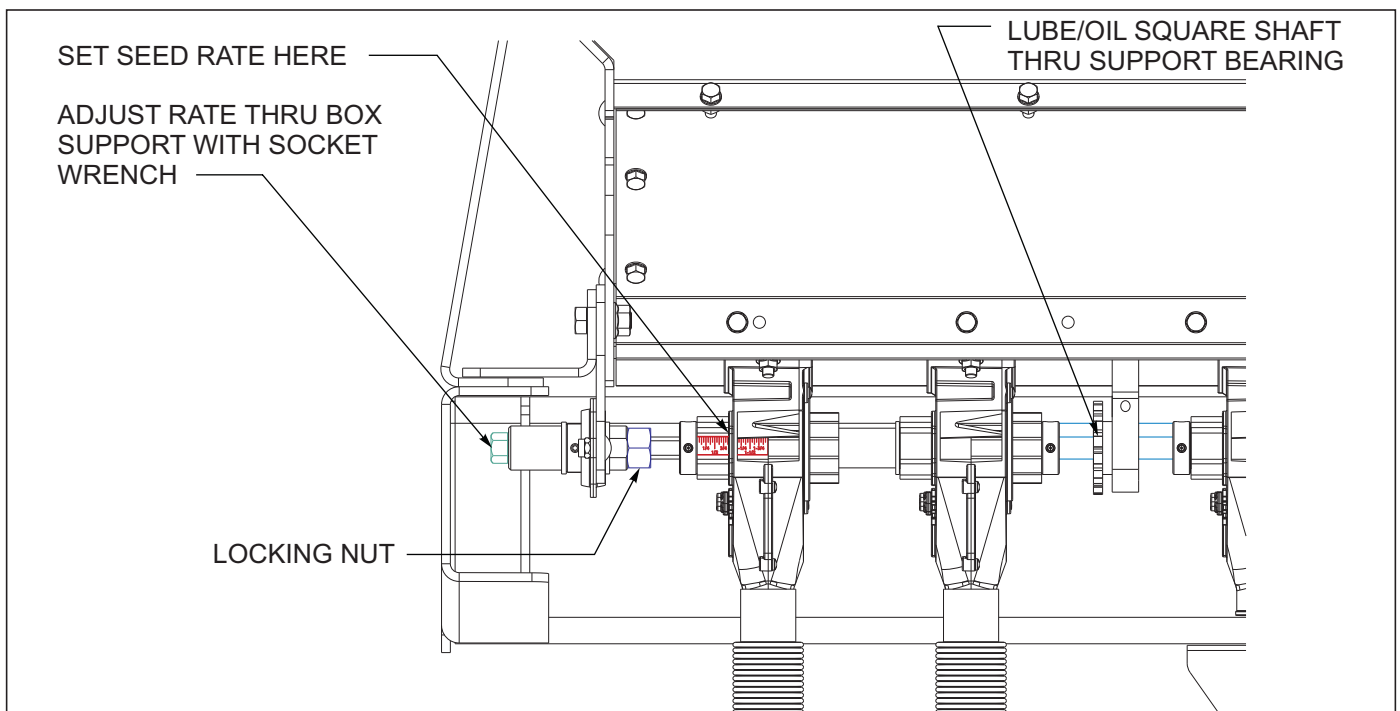

Figure 4-16: Seed Rate Adjustment

Meter/Seed Rate Handle Adjustment

1. If the seed meter shaft is disassembled for maintenance or repair the seed meters and adjustment handle will need to be reset or zeroed to set the meters equally across the section.
2. Remove any remaining seed from the seed box.
3. To reset the meters, loosely reassemble the shaft, meters, spacers, locking collars etc. but leave the locking collars loose.
4. Tighten the threaded seed shaft adjustment to hold in place.
5. Start with the end meter(s) next to the threaded adjustment *See Figure 4-16*. Slide the feed roll and cut-off to the right until the indicator reads zero on the end meter. Remove any remaining slack between the spacers, washers, feed rolls etc. and secure the lock collars on each end of that group of meters. Continue to work across the drill section sliding the meter feed rolls to the right, removing any slack, and securing the lock collars for each group of meters.
6. With all lock collars secure on the seed shaft and all slack removed from between the spacers, verify that each meter is actually zeroed out. The feed roll should not be protruding or recessed inside any of the meters. To fine tune each meter, if necessary, loosen the two bolts holding the meter housing to the bottom of the seed box. Slide the meter housing to the right or left, until the meter is zeroed out. Re-tighten the meter housing to the bottom of the seed box.
7. Set the seed rate adjustment to the desired rate *See Figure 4-17*.

NOTE

Do not force the seed meter shaft, damage will occur.

TABLE OF CONTENTS



SEEDING RATE CHART

Seeding rates are in pounds per acre, based on average seed size.
Rates are approximate, operator must verify actual seeding output.

SEED	ALFALFA				BARLEY				FESCUE				MILLET				MILO				OATS				RICE				SOYBEAN				WHEAT				SEED													
	7-1/2		10		7-1/2		10		7-1/2		10		7-1/2		10		7-1/2		10		7-1/2		10		7-1/2		10		7-1/2		10																			
	DRIVE	I	II	I	II	DRIVE	I	II	I	II	DRIVE	I	II	I	II	DRIVE	I	II	I	II	DRIVE	I	II	I	II	DRIVE	I	II	I	II	DRIVE	I	II	I	II	DRIVE		I	II	I	II									
1/8	8	4	6	3						4	2	3	1	8	4	6	3	9	4	6	3																	10	5	7	4	1/8								
1/4	16	8	12	6	3	14	7	10	5	8	4	6	3	15	7	11	6	16	8	12	6											17	9	13	7	26	13	19	7	29	14	21	11	3/8						
3/8	24	12	18	9	21	10	15	8	11	6	9	5	23	11	17	9	26	13	19	10											23	12	18	9	38	19	28	14	38	19	29	14	1/2							
1/2	32	16	24	12	28	14	21	10	16	8	12	6	31	15	23	11	37	18	28	14											30	15	23	11	37	19	29	14	66	33	50	25	61	31	46	23	3/4			
5/8	40	20	30	15	36	18	27	13	19	9	14	7	39	20	29	15	48	24	36	18											36	18	27	13	44	22	33	17	82	41	61	31	73	36	54	27	7/8			
3/4	49	25	36	19	44	22	33	16	23	12	18	9	48	24	36	18																41	20	31	16	51	26	38	19	94	47	70	35	84	42	63	32	1		
7/8	58	29	43	22	52	26	39	20	28	14	21	11	58	29	43	22																48	24	36	18	59	30	44	22	112	56	84	42	97	49	73	36	1-1/8		
1	66	33	49	25	60	30	45	23	31	16	23	12	67	33	50	25																54	27	40	20	67	33	50	25	131	65	98	49	110	55	83	41	1-1/4		
1-1/8					70	35	52	26	36	18	27	14																			61	30	46	23	75	38	56	28	152	76	114	57	124	62	93	46	1-3/8			
1-1/4					79	39	59	30	40	20	30	15																				69	34	51	26	85	42	64	32	162	81	122	61	140	70	105	52	1-1/2		
1-3/8					89	44	67	33	44	22	33	17																				77	39	58	29	95	48	71	36	182	91	137	68	157	78	118	59	1-5/8		
1-1/2					100	50	75	38	47	24	35	18																				84	41	62	31	103	52	77	39	185	95	140	70	170	85	127	64	1-3/4		
1-5/8					113	56	84	42	52	26	39	20																																						
1-3/4					122	61	91	46	55	28	41	21																																						

24T - 43T

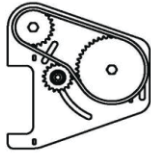

TYPE I

12T - 43T

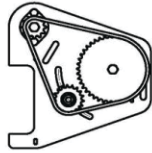

TYPE II

24T - 22T

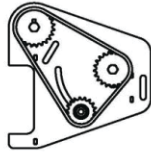

TYPE III

Note:

- Drive type I is standard speed
- Drive type II is half speed
- Drive type III is double speed

176490

$$\text{SEED RATE} = \frac{(\text{AVG SEED WEIGHT}) \times 65896}{(\text{NO. OF ROTATIONS}) \times (\text{ROW SPACING})}$$

EXAMPLE = $\frac{(.1707 \text{ LBS.}) \times 65896}{(20 \text{ ROTATIONS}) \times (7.5")}$ = **75 LBS./ACRE**

$$\# \text{ SEEDS per ROW} = \frac{(\text{SEED RATE}) \times (\text{SEEDS/LB}) \times (\text{NO. OF ROTATIONS}) \times (\text{ROW SPACING})}{65896}$$

EXAMPLE = $\frac{(60 \text{ LBS./ACRE}) \times (2500 \text{ SEEDS/LBS.}) \times (20 \text{ ROTATIONS}) \times (7.5")}{65896}$ = **341 SEEDS PER ROW**

$$\# \text{ SEEDS per ROW} = \frac{(\text{POPULATION}) \times (\text{NO. OF ROTATIONS}) \times (\text{ROW SPACING})}{65896}$$

EXAMPLE = $\frac{(50,000 \text{ POPULATION}) \times (20 \text{ ROTATIONS}) \times (7.5")}{65896}$ = **114 SEEDS per ROW**

Figure 4-17: Seed Rate Chart and Calibration Formulas

Seed Rate Calibration

1. The seed rate charts are in pounds per acre and based on an average seed size *See Figure 4-17*. Several factors can influence seeding rates: seed varieties, seed size, seed weight, seed treatment, seed cleanliness, tire pressure, tire slippage, and tire size.

NOTE

The operator must verify actual seed output before planting to insure the desired seeding rate.

2. If the specific seed is not listed on the seed chart, pick a similar seed size and check the seed calibration for the desired rate.
3. To check the seeding rate:
 - a. Adjust the seeding rate handle and drive type to the desired rate from the seed chart *See Figure 4-17*.
 - b. Select three seed meters next to each other, and disconnect the rubber seed tubes to be able to catch the seed.
 - c. Fill the box with a sufficient amount of seed over the three meters.
 - d. Lower the openers to planting position to engage the seed clutch.
 - e. Place a jack under the appropriate drive wheel and raise off the ground so the drive wheel may be rotated by hand.
 - f. Collect the seed from the three seed meters as you rotate the drive wheel by hand. Count the total number of rotations. Twenty rotations would be a good starting point; more rotations will produce more accurate results.
 - g. Weigh (in pounds) the total amount of seed and divide by 3 for an average amount of seed per meter. *See Figure 4-17* for seed rate formula.
4. Adjust the seed meter rate to compensate for any variation, and repeat the seed calibration until the desired seeding rate is achieved.
5. *See Figure 4-17* for number of seeds per row formula.

Dry Fertilizer Combination Box

1. If the Grain Drill is equipped with the dry fertilizer option, it will have a combination seed/fertilizer box. The seed/fertilizer box is split for approximately 60% (2 bu/ft) seed and 40% (1.25 bu/ft) fertilizer. The box may be used for applying both seed and fertilizer, or converted to use both compartments entirely for seed.
 - a. To use the dry fertilizer option, the covers in the bottom of the rear fertilizer compartment must have the openings to the rear *See Figure 4-18*. This will close off openings to the seed compartment and allow dry fertilizer to enter the fertilizer meters.
 - b. For increased seed capacity and non fertilizer use, the covers should be reversed with the openings to the front of the seed box, and the solid portion covering the fertilizer meters *See Figure 4-19*.
2. To change the fertilizer covers, remove the plastic knobs holding each of the covers in place at the bottom of the rear fertilizer compartment. Lift the cover out, and reposition the cover with the openings to the front or rear as desired. Insure the cover is slid down to the bottom and reinstall the plastic knobs to retain the covers.

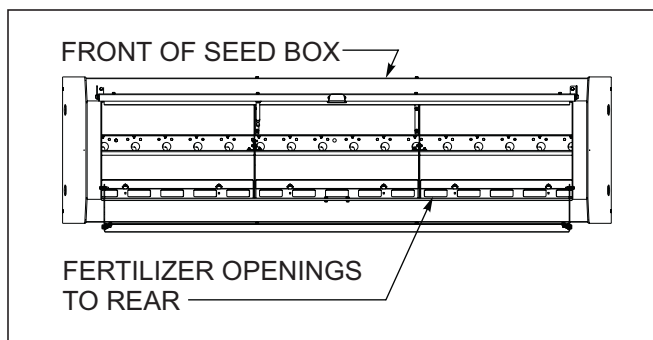

Figure 4-18: Fertilizer Box w/Cover Opening to Rear

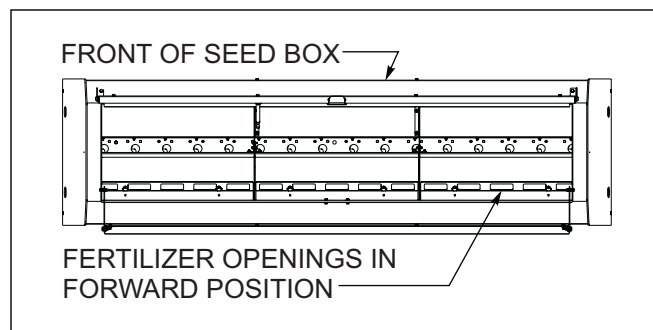

Figure 4-19: Fertilizer Box w/Cover Opening Forward

3. When using both seed and dry fertilizer, fill the seed box keeping fill shield in closed position over fertilizer box **See Figure 4-20.**

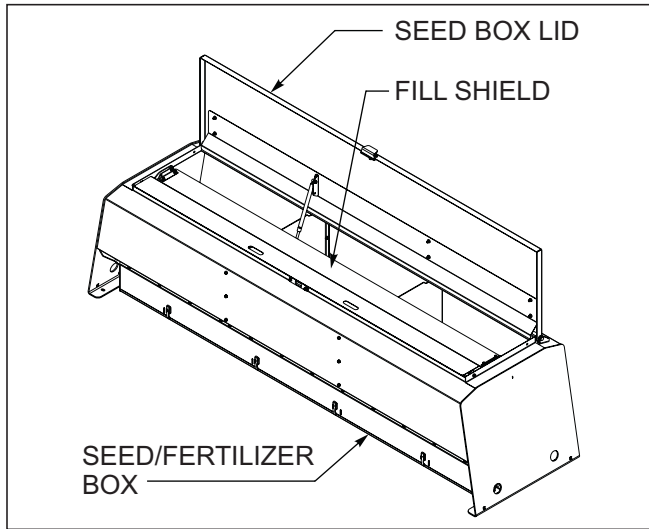

Figure 4-20: Fill Shield in the Closed Position

4. When using both seed and dry fertilizer, open fill shield up shielding the seed box and fill with dry fertilizer **See Figure 4-21.**

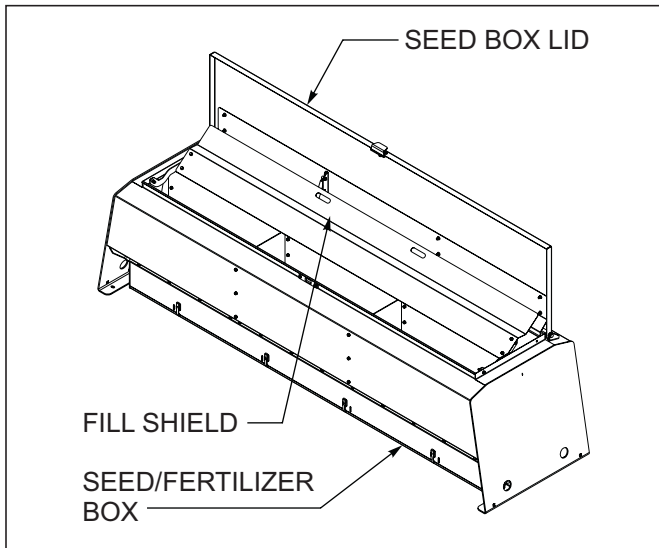

Figure 4-21: Fill Shield in Raised Position

5. When both compartments are being used for seed, open seed box lids and lift and rotate the fill shield over the rear of the seed box. This allows the compartments to be filled at the same time. This also improves access for maintenance and cleaning **See Figure 4-22.**

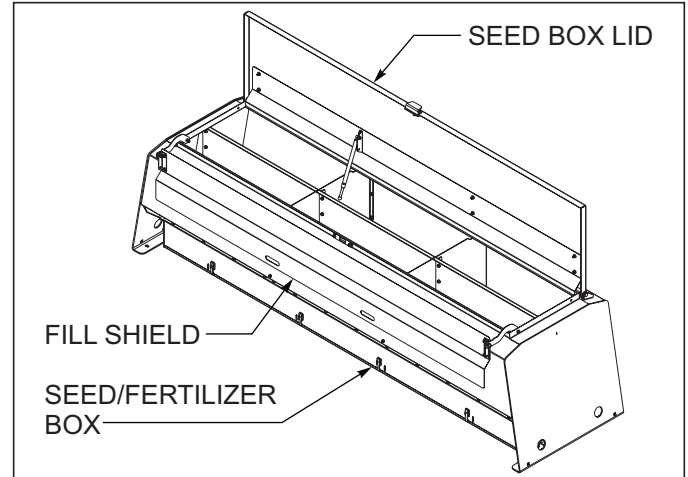

Figure 4-22: Both Compartments Filled w/ Seed

Fertilizer Box – Clean Out

1. The fertilizer meters may be accessed for maintenance or cleaning by removing the door located at the bottom of the fertilizer meter assembly
See Figure 4-23.
2. Remove any remaining dry fertilizer from inside the fertilizer compartment. Be prepared to catch the remaining fertilizer before opening the door. Position the drill over a smooth, clean, dry surface, or spread out a tarp below the box. Release and unhook the
3. latches and allow the door to swing forward.
3. Dry fertilizer is very corrosive and absorbs moisture. Clean out any fertilizer as soon as possible after using the drill.
4. Storage – before storing the drill for extended periods, clean out any remaining seed and fertilizer from the boxes. Remove the fertilizer doors on the outside of the box and fertilizer covers on the inside of the box. Use water to wash out any remaining fertilizer within the boxes and in the fertilizer meter assemblies.

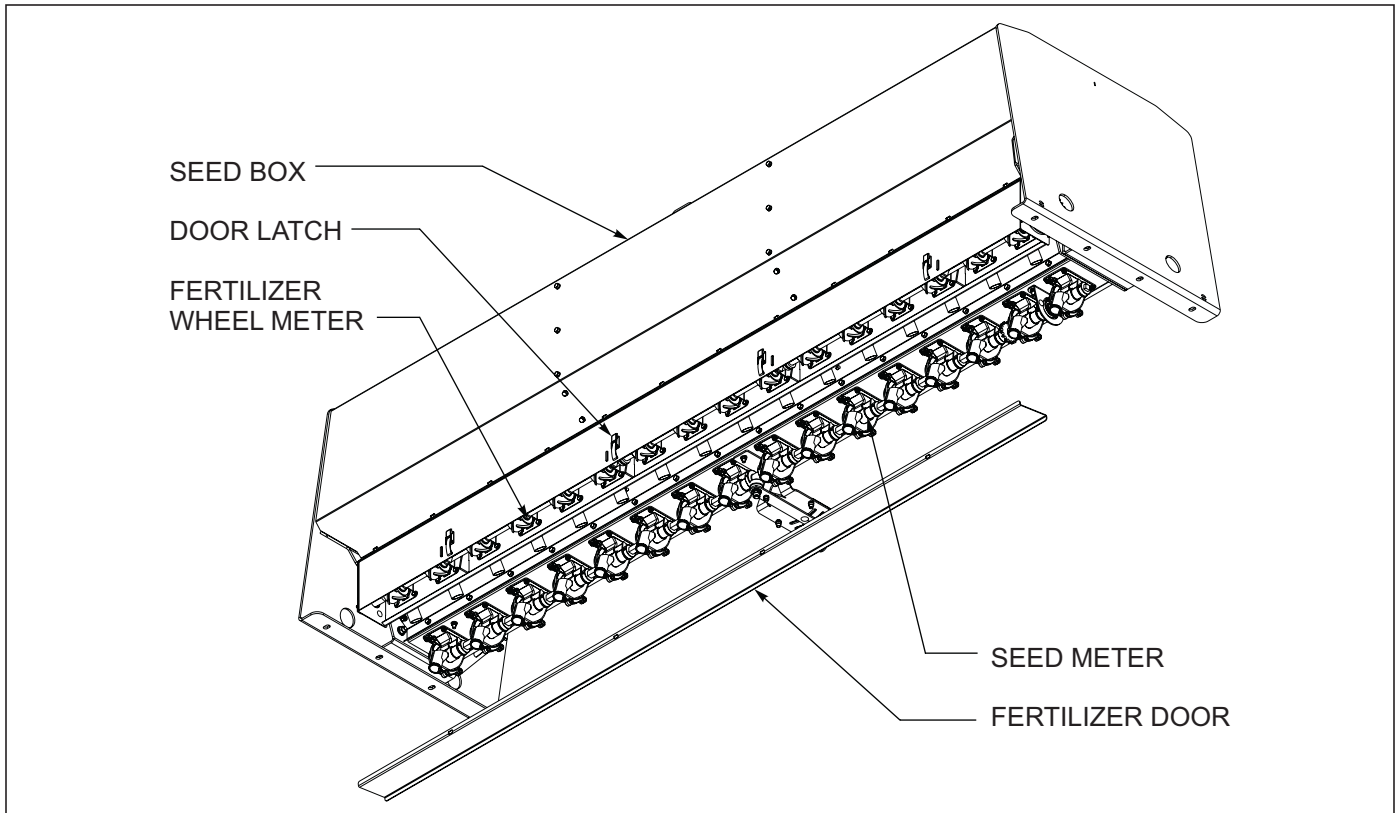

Figure 4-23: Fertilizer Box Clean Out

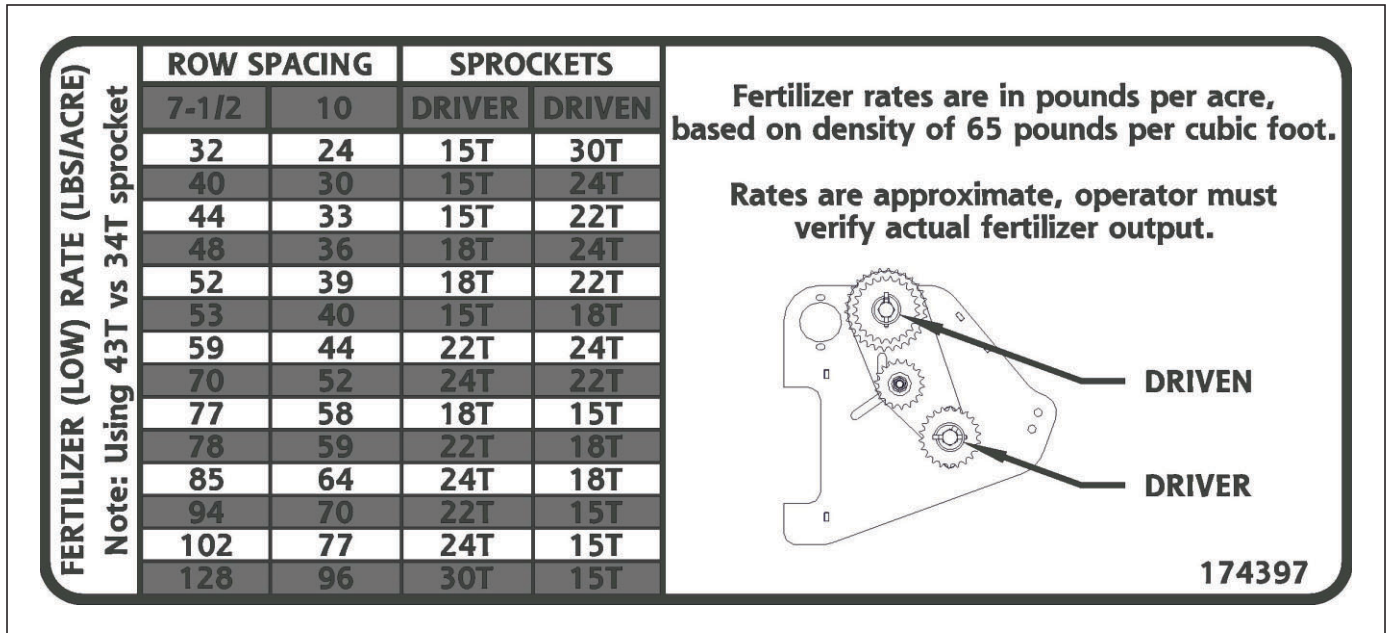

Figure 4-24: Fertilizer Box Chart

Fertilizer – Rate Adjustment

1. The dry fertilizer rate is adjusted by changing sprocket ratios for each section. *See Figure 4-24* for desired settings. For best results use clean dry fertilizer, free of clumps, or foreign material.

2. The fertilizer chart is based upon average size dry fertilizer with a density of 65 lbs per cubic foot. If using a fertilizer with a different density, apply the following conversion factors, and use the closest rate for application *See Table 4-1*.

IMPORTANT

The operator must verify actual fertilizer output before planting.

Dry Fertilizer Density Conversion Chart Based on Average Density of 65 lbs./ft.							
Density	50	55	60	65	70	75	80
Conversion Factor	1.30	1.18	1.08	1.00	.93	.87	.75

Example: using a dry fertilizer with a density of 70 lbs/ft³ and a desired application rate of 50 lbs/acre.

50 x .93 = 46.5 (use a setting from the rate chart nearest 46.5 lbs/acre)

Table 4-1: Dry Fertilizer Density Conversion Chart

Fertilizer – Rate Calibration

1. Dry fertilizer can be affected by type, density, size, humidity, and field conditions. Operator should verify actual fertilizer rate output before planting.
2. To check the fertilizer rate:
 - a. With a desired fertilizer rate and known density apply the above conversion factor and select rate from chart. If density is not known, use desired rate based on 65 lbs/ft³ from the chart.
 - b. Adjust the sprocket ratio to the desired rate.
 - c. Select three fertilizer meters next to each other and disconnect the rubber tubes from these meters to be able to collect fertilizer.
 - d. Fill the fertilizer box with a sufficient amount of fertilizer over the top of the three meters.
 - e. Lower the openers so the drive wheel clutch will engage.
 - f. Place a jack under the appropriate drive wheel and raise off the ground so the drive wheel may be rotated by hand.
 - g. Rotate the drive wheel several times, until the three meters begin to deliver fertilizer evenly.
 - h. With an empty container begin collecting the fertilizer from the three meters as you rotate the drive wheel by hand. Count the total number of rotations. Twenty rotations would be a good starting point; more rotations will produce more accurate results.
 - i. Weigh (in pounds) the total amount of fertilizer (less the container) and divide by 3 for an average amount of fertilizer per meter.

$$\text{FERTILIZER RATE} = \frac{(\text{AVG FERTILIZER WT}) \times 65896}{(\text{NO. OF ROTATIONS}) \times (\text{ROW SPACING})}$$

$$\text{EXAMPLE} = \frac{(.1138 \text{ LBS.}) \times 65896}{(20 \text{ ROTATIONS}) \times (7.5" \text{ SPACING})} = 50 \text{ LBS./ACRE}$$

3. Compare the actual fertilizer rate with the starting rate and compensate for any variation. Repeat the calibration until the desired fertilizer rate is achieved. Adjust the sprocket ratios on the other sections to match the calibrated setting.
4. Continue to monitor the fertilizer rate while planting. Note the amount of acres planted versus the amount of fertilizer added to the drill. If you are applying more or less fertilizer than desired, adjust the metering rate to compensate for field conditions and fertilizer.

Small Seed Rate Adjustment



WARNING

- To prevent damage to the seed meters, do not apply excessive force to the adjusting nuts. Failure to do so may result in the seed being pinched between the cut-off and washer inside the seed cup.
- Do not close the meters more than 1/8" when there is seed in the meters without rotating the seed shaft. This prevents damage to the rotating washers and retainer rings in the seed meters.
- Do not attempt to open meters more than 1". (Feed rolls could become disengaged from washer in the seed cup.)

NOTE

To avoid seed meter damage, if there is seed in the meters, decrease rate in small increments. Decrease rate no more than one nut revolution and rotate seed shaft to purge seed from meters. Continue adjustments as needed.

NOTE

Before filling with seed be sure seed shaft turns freely and seed meters are free from any foreign matter.

1. The seeding rate adjustment for the optional small seeding attachment is located at the outer rear of each seeding box. The seeding rate should be set the same for all seeding boxes. On 40' drills there will be two adjustments to be made to each wing.
2. The small seeding rate is set independent of the seeding rate and drive type on the main seeding hopper.
3. Adjustments to the small seeding attachment will be easier if the boxes are empty of seed before adjusting. The meters will not be able to be fully closed if there is seed in the hopper. Do not force the adjustment or damage may occur to the meters.
4. To set the seeding rate:
 - a. First determine from the seeding rate chart inside seed box cover, the meter opening for the desired seed rate **See Figure 4-27**. It should be used as a general guide only.
 - b. Rotate the small seed shaft until the letters and numbers on the adjustment are clearly visible **See Figure 4-26**.

- c. Wrenches are provided to adjust the seed rate. They are stored on outside end of LH seed box *See Figure 4-14*.
- d. Loosen the 1" locking nut with the seed rate adjusting wrench *See Figure 4-25* and *See Figure 4-26*.
- e. Turn the large seed rate adjusting nut with the adjustment wrench of the seed shaft bearing in or out to the desired setting *See Figure 4-25* and *See Figure 4-26*. The desired letter on the seed rate adjusting nut should be aligned with the number scale. The face of the nut should align to the desired number setting.

- f. Re-tighten the 1" locking nut with the seed rate adjusting wrench against the bearing.

NOTE

Seeding rates are based on clean untreated average size seed. Actual rates may vary, operator must verify actual seed output. If a specific seed is not listed, use a seeding rate for a similar sized seed, and verify output before planting.

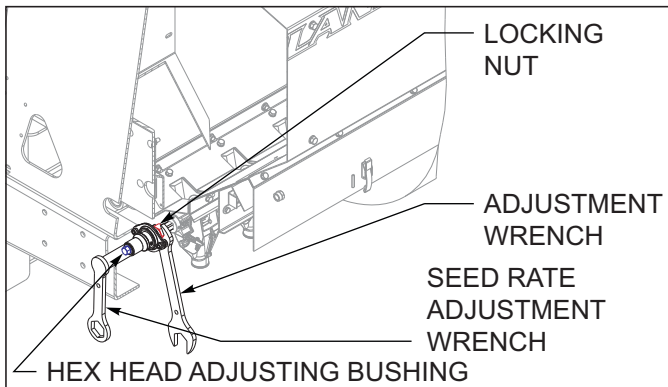

Figure 4-25: Wrench Adjustment Position

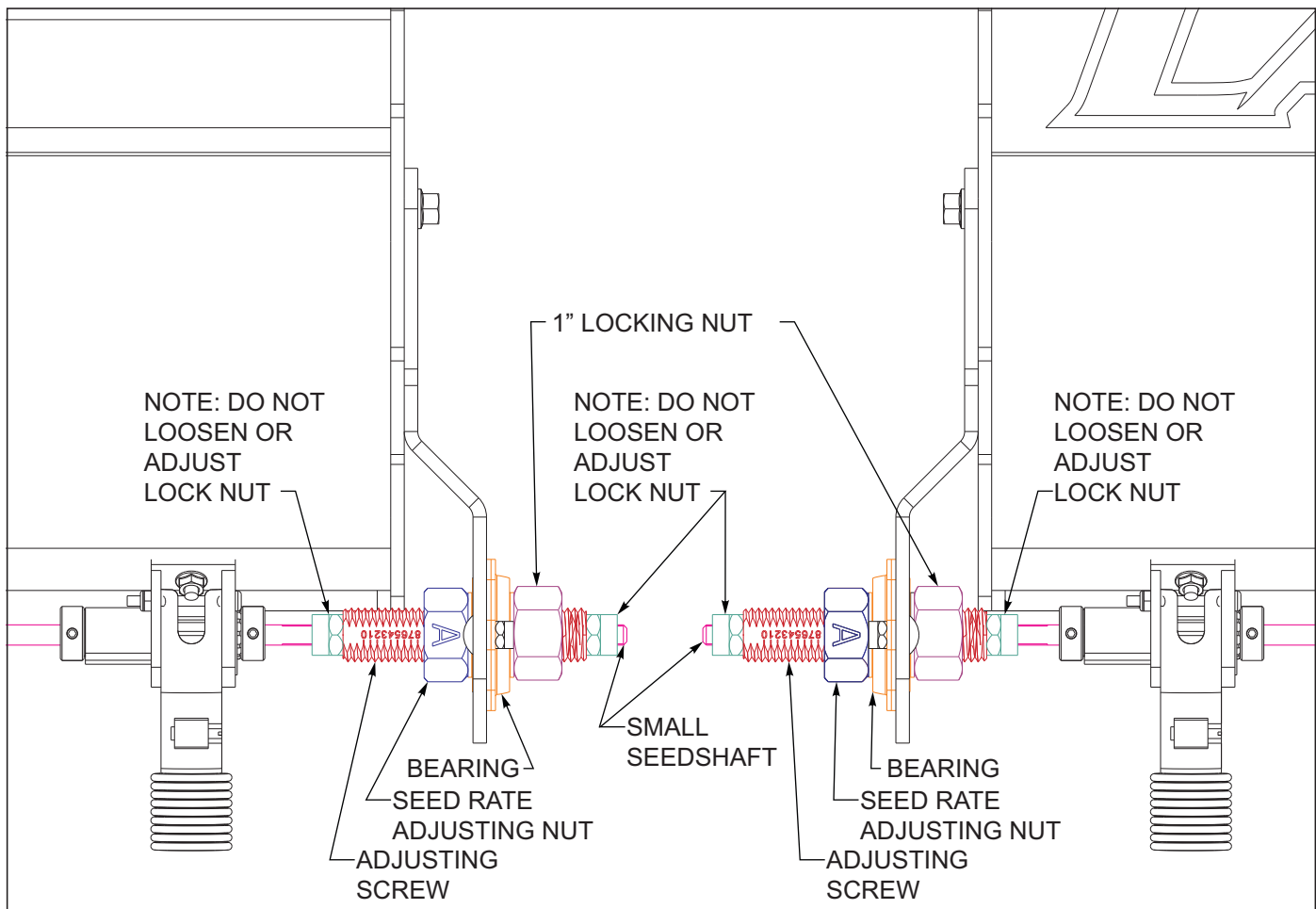

Figure 4-26: Small Seed Rate Adjustment

Seed Rate Calibration

1. The seed rate charts are in pounds per acre and based on an average seed size 7-1/2" spacing **See Figure 4-27** or 10" spacing **See Figure 4-28**. Several factors can influence seeding rates: seed varieties, seed size, seed weight, seed treatment, seed cleanliness, tire pressure, tire slippage, and tire size.

NOTE

The operator must verify actual seed output before planting to insure the desired seeding rate.

2. If the specific seed is not listed on the seed chart, pick a similar seed size and check the seed calibration for the desired rate.
3. To check the seeding rate:
 - a. Select three seed meters next to each other, and disconnect the rubber seed tubes to be able to catch the seed.
 - b. Fill the box with a sufficient amount of seed over the three meters.

- c. Lower the openers to planting position to engage the seed clutch.
 - d. Place a jack under the appropriate drive wheel and raise off the ground so the drive wheel may be rotated by hand.
 - e. Collect the seed from the three seed meters as you rotate the drive wheel by hand. Count the total number of rotations. Twenty rotations would be a good starting point; more rotations will produce more accurate results.
 - f. Weigh (in pounds) the total amount of seed and divide by 3 for an average amount of seed per meter. 7-1/2" spacing **See Figure 4-27** or 10" spacing **See Figure 4-28**. For rate calibration formula **See Figure 4-17**.
4. Adjust the seed meter rate to compensate for any variation, and repeat the seed calibration until the desired seeding rate is achieved.

TABLE OF CONTENTS

		SMALL SEED RATE CHART								SEEDING RATES ARE ARE IN POUNDS PER ACRE, BASED ON AVERAGE SEED SIZE. RATES ARE APPROXIMATE, OPERATOR MUST VERIFY ACTUAL SEEDING OUTPUT. 174412										
		SEED	ROW SPACING	INDICATOR SETTING								SEED	ROW SPACING	INDICATOR SETTING						
			1A	2A	3A	4A	5A	6A	7A	8A			1A	2A	3A	4A	5A	6A	7A	8A
ALFALFA (Uncoated)	7-1/2	2	5	10	14	17	22	25	29	LESPEDEZA (Hulled)	7-1/2	2	5	10	14	17	22	27	30	
ANNUAL RYE GRASS	7-1/2	1	3	5	8	10	14	16	18	LESPEDEZA (Unhulled)	7-1/2	1	4	7	10	15	18	22	25	
BIRDSFOOT TREFOIL	7-1/2	2	7	10	15	22	27	33	38	LOVE GRASS (Sand)	7-1/2	2	5	8	12	16	20	25	29	
BLUEGRASS (Kentucky)	7-1/2	1	2	3	5	7	8	10	11	LOVE GRASS (Weeping)	7-1/2	1	7	10	14	18	23	28	33	
BLUEGRASS (Park Kentucky)	7-1/2	1	3	5	8	10	14	16	18	MILLET	7-1/2	2	7	10	15	19	23	28	33	
CANOLA	7-1/2	1	5	8	13	16	19	22	27	ORCHARD GRASS	7-1/2	-	1	2	3	4	5	6	7	
CLOVER (Crimson)	7-1/2	2	5	8	13	18	21	25	32	RED TOP	7-1/2	1	2	4	5	7	8	9	10	
CLOVER (Ladino, Sweet, Red)	7-1/2	2	7	10	14	18	22	25	30	REED CANARY GRASS	7-1/2	1	2	4	6	8	10	12	14	
KLEIN GRASS	7-1/2	2	5	10	14	19	25	30	33	TIMOTHY	7-1/2	2	4	7	12	15	19	23	27	

Figure 4-27: 7-1/2" Grass Seed Rate Chart

		SMALL SEED RATE CHART								SEEDING RATES ARE ARE IN POUNDS PER ACRE, BASED ON AVERAGE SEED SIZE. RATES ARE APPROXIMATE, OPERATOR MUST VERIFY ACTUAL SEEDING OUTPUT. 249356										
		SEED	ROW SPACING	INDICATOR SETTING								SEED	ROW SPACING	INDICATOR SETTING						
			1A	2A	3A	4A	5A	6A	7A	8A			1A	2A	3A	4A	5A	6A	7A	8A
ALFALFA (Uncoated)	10	2	4	8	11	13	17	19	22	LESPEDEZA (Hulled)	10	2	4	8	11	13	17	20	23	
ANNUAL RYE GRASS	10	1	2	4	6	8	11	12	14	LESPEDEZA (Unhulled)	10	1	3	5	8	11	14	17	19	
BIRDSFOOT TREFOIL	10	2	5	8	11	17	20	25	29	LOVE GRASS (Sand)	10	2	4	6	9	12	15	19	22	
BLUEGRASS (Kentucky)	10	1	2	2	4	5	6	8	8	LOVE GRASS (Weeping)	10	1	5	8	11	14	17	21	25	
BLUEGRASS (Park Kentucky)	10	1	2	4	6	8	11	12	14	MILLET	10	2	5	8	11	14	17	21	25	
CANOLA	10	1	4	6	10	12	14	17	20	ORCHARD GRASS	10	-	1	2	2	3	4	5	5	
CLOVER (Crimson)	10	2	4	6	10	14	16	19	24	RED TOP	10	1	2	3	4	5	6	7	8	
CLOVER (Ladino, Sweet, Red)	10	2	5	8	11	14	17	19	23	REED CANARY GRASS	10	1	2	3	5	6	8	9	11	
KLEIN GRASS	10	2	4	8	11	14	19	23	25	TIMOTHY	10	2	3	5	9	11	14	17	20	

Figure 4-28: 10" Grass Seed Rate Chart

Small Seed Meter Assembly/Adjustment

1. If the small seed meter shaft assembly is disassembled for maintenance or repair, the seed meters and seed rate adjustment will need to be reset or zeroed to set the meters equally across the seed box.
2. To reset the seed meters, remove all seed, chaff, and dirt from the seed box and seed meters. Reassemble the meters and drive shaft assembly, but leave the locking set collars, meter feed rolls and meter cut-offs loose on the shaft. Leave the drive chain disconnected as well.
 - a. Set the seed rate adjusting nut to "0A", and tighten the large locking nut against the right side of the seed shaft bearing. The two smaller 1/2" locking nuts should be tight against the threaded adjusting screw as well.
 - b. For each seed meter, slide the meter feed roll and cut-off to the right to fully close each meter. Slide the locking collar on the left side of each meter against the meter cut-off and tighten the lock collar.
 - c. For each seed meter, slide the right locking set collar next to the meter feed roll (leaving .010"-.020" of clearance) and tighten the set collar. Make sure the flutes on the meter feed roll are lined-up and inserted in the meter housing.
 - d. Rotate the square seed shaft by hand to verify the shaft is not binding and rotates freely.
 - e. Loosen the large locking nut against the seed shaft bearing. Adjust the seed shaft in and out to make sure all meter feed rolls are properly aligned and not binding. Do not force the adjustment or damage will occur to the meter assembly.
 - f. Reconnect the drive chain.
 - g. Set the seed rate adjustment to the desired rate and tighten the locking nut.
3. The seed meters should now be reset to zero, and match the zero indication on the adjusting screw.

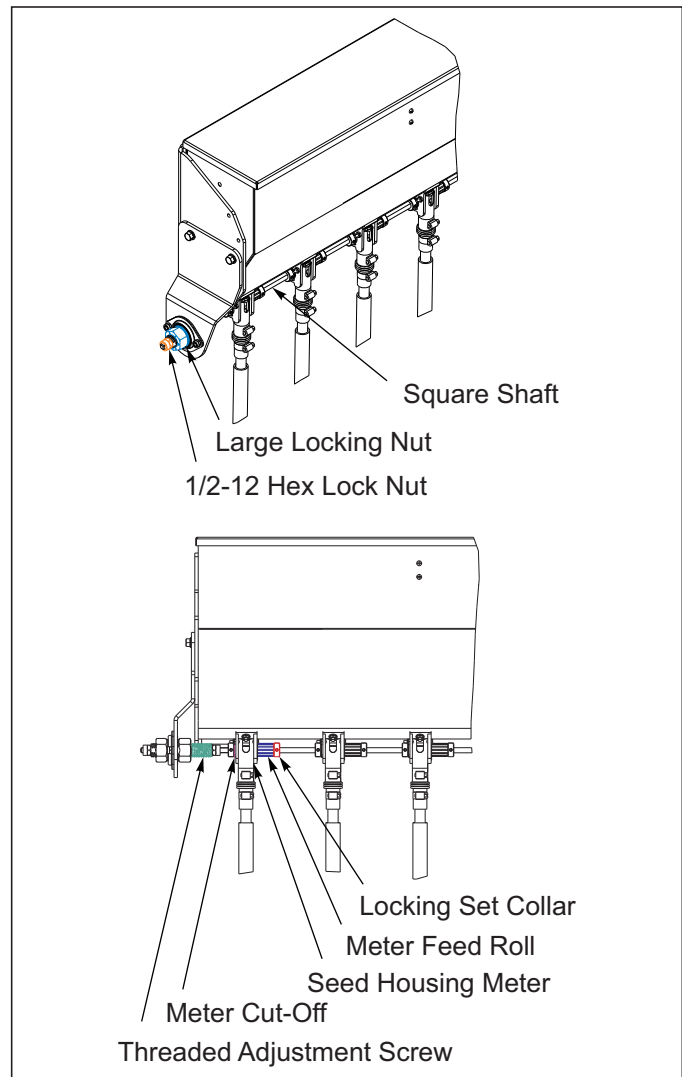

Figure 4-29: Small Seed Rate Adjustment

Small Seed Disconnect

1. To disconnect the small seed box, locate the seed drive sprocket at the front and outer end of the seed boxes. Drills equipped with the optional small seed attachment have a quick disconnect installed on the seed shaft. This allows the operator to disconnect the small seed box drive for each section when not in use, and just use the main seed box.
2. On 40' wings it will be in the middle of the section. There are disconnects for each section. Pull the T-handle out and rotate the lock pin 90 degrees. To engage the seed drive pull out and rotate the T-handle until the handle aligns with the groove in the pin. Rotate the seed shaft by hand, until the lock pin engages the sprocket. Verify that all small seed drive sections are rotating when starting planting.

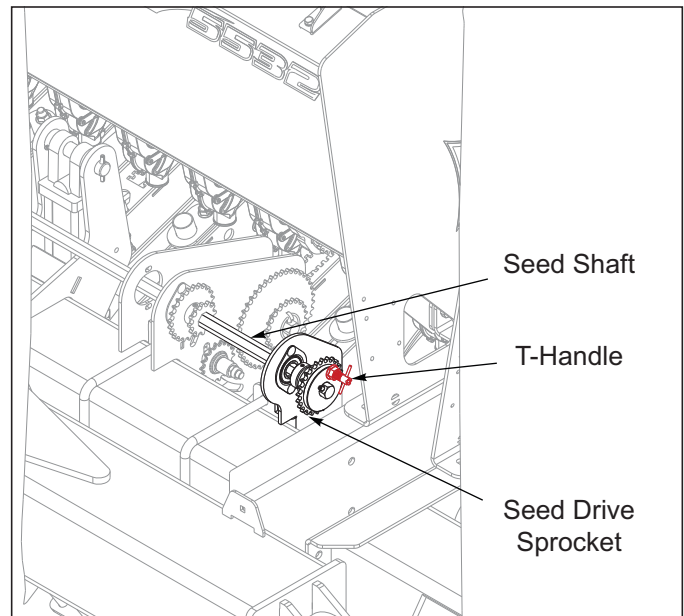

Figure 4-30: Small Seed Disconnect

Air Spring Adjustment

1. The air pressure delivered to the air springs is the same for all openers. To be able to increase the down pressure for specific row units such as in wheel track locations, the air spring has two mounting positions. The normal position is forward, with a heavier setting by sliding the air spring to the rear. The heavier setting will increase the down pressure by approximately ten percent.



CAUTION

Relieve system air pressure before attempting to adjust or service any air spring component. Make sure all components are in place and secure before charging the system.

IMPORTANT

Make sure the air spring has fully reached the ends of the top and bottom slots before retightening. If the air spring is not in the ends of the slot, it will be out of alignment and can rub internally wearing a hole. Also, be sure the air spring is not twisted when re-tightening the fasteners.

3. Re-tighten the top jam nut and bottom hex head cap screw to secure the air spring. Recharge the system with air to normal working pressure.

NOTE

Maximum torque on the top jam nut is 30 ft. lbs.

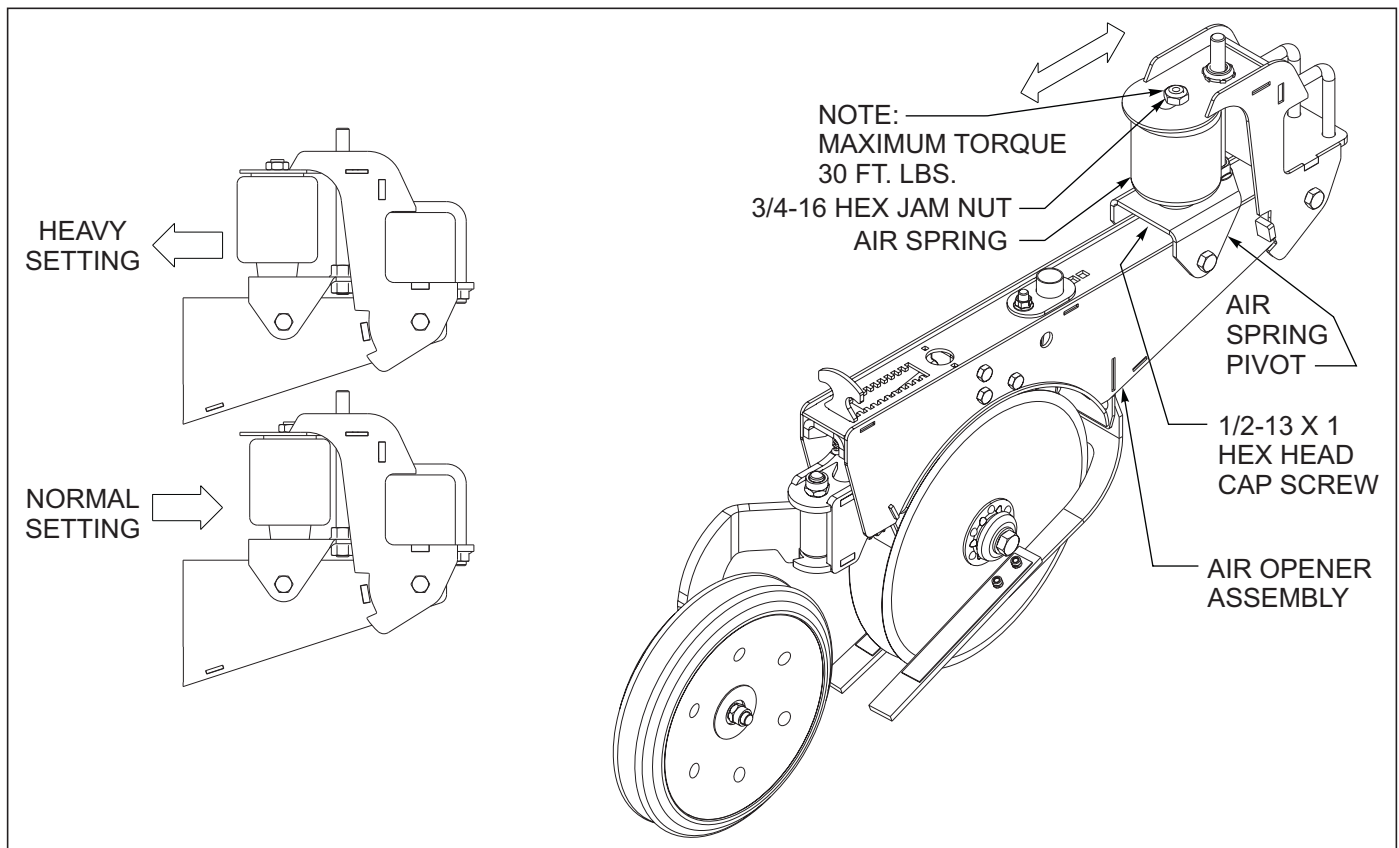

Figure 4-31: Air Spring Adjustment

Opener Blade Adjustment

1. To insure peak performance of the opener assembly and maximum bearing life a proper opener blade pinch point should be maintained. The pinch point of the blades is the lower front point where the right and left opener blade come in contact with each other, and enter the ground.

! DANGER

Opener blades are extremely sharp. Exercise extreme care when working on or near opener blades. Do not allow opener blades to roll over or fall onto any body part. Do not allow wrenches to slip when working near blades. Never push wrenches toward opener blades. Do not climb over machine above opener blades. Failure to stay clear of opener blade edges can cause serious personal injury or death.

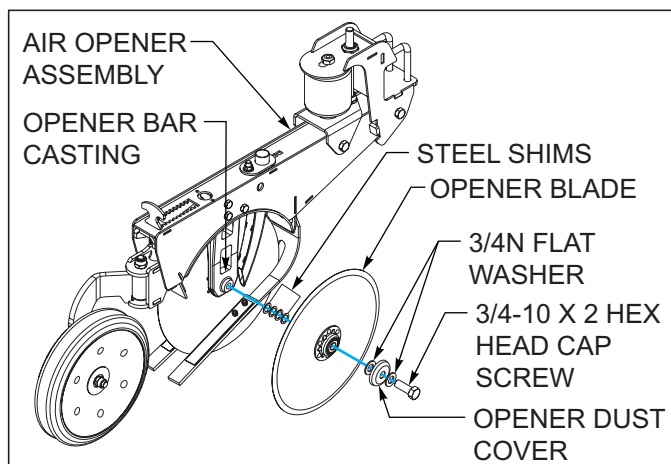

Figure 4-32: Opener Blade Adjustment

2. A properly maintained pinch point will allow the opener to penetrate better and create a smoother seed trench for better seed placement. A pinch point that is too wide will allow soil/mud to build up between the opener blades regardless of how the scraper may be adjusted. A pinch point that is too wide or too narrow can excessively preload the opener bearings and lead to premature bearing failure, particularly in heavy soils or no till applications.
3. The pinch point is adjusted by adding/removing shims from between the opener blade and opener casting **See Figure 4-32**. When removing shim(s) from between the blade and the casting, move them to the outside of the blade and place under the dust cap. Do not discard shims. This will keep track of the shims and not change the length of bolt required. Adjust the shims as equally as possible so there are similar number of shims under the right and left blades.

Example 3 & 3, or 3 & 2.

Opener blades must turn freely and not bind.

Opener blades must maintain contact at pinch point while rotating.

The amount of pinch point contact can be verified by inserting a .015" thick shim (business card) above and below the pinch point where the blades meet. Measure the distance between the two shims at the edge of the disc blade. Rotate blades 1/2 turn to recheck the pinch point distance. Average distance should be between 1-1/2" and 2-1/2".

If the distance is not within the specified range, adjust by adding or removing shims to inside of the opener disc blade assemblies.

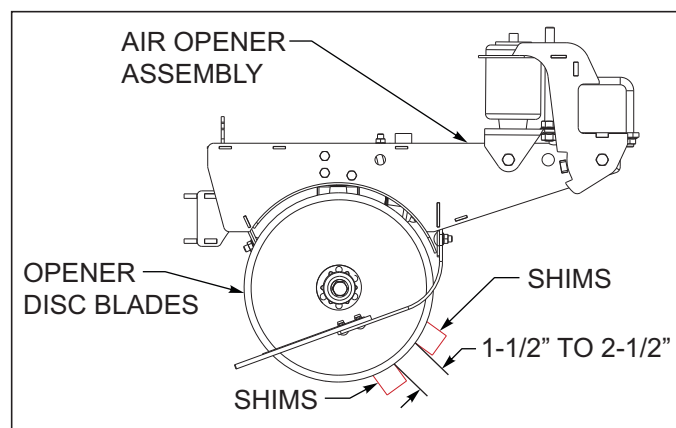

Figure 4-33: Opener Blade Pinch Point Adjustment

4. As the opener blades wear, it will be necessary to adjust the pinch point to maintain the pinch point. No till planting applications will generate more wear and more frequent pinch point adjustment.

Opener Blade Wear

New opener blade diameter is 15-3/4" (400mm). Typical blade wear life is 1". Replace the opener blade if the diameter is less than 14-3/4" (375mm) or uneven seed depth occurs. Operating blades below this diameter will limit planting depth and adjustment. Opener blade pinch point should be maintained throughout the life of the blade. Blade wear below the 14-3/4" diameter can lead to interference with the seed tube and scraper and inability to maintain the pinch point.

Opener – Press Wheel Adjustment

1. The seeding depth of each individual opener is controlled by the press wheel depth adjustment **See Figure 4-34**. To change the depth of each press wheel, raise the openers so there is not any weight on the press wheel. Pull up on the adjusting handle and slide the depth stop forward or rearward to obtain the desired seeding depth. Each notch represents approximately 5/16" in depth. Slide the handle forward for shallower seed placement, and rearward for deeper seed placement.

NOTE

Increasing opener down pressure does not increase seed placement depth.

2. As long as the press wheel is carrying weight, the seeding depth is regulated by the press wheel adjustment. An increase in down pressure does not change the depth of seed placement.

3. Make sure the hitch is level when planting to insure consistent planting depth. A hitch that is too high or too low can change how the press wheel contacts the ground and affect seeding depth.

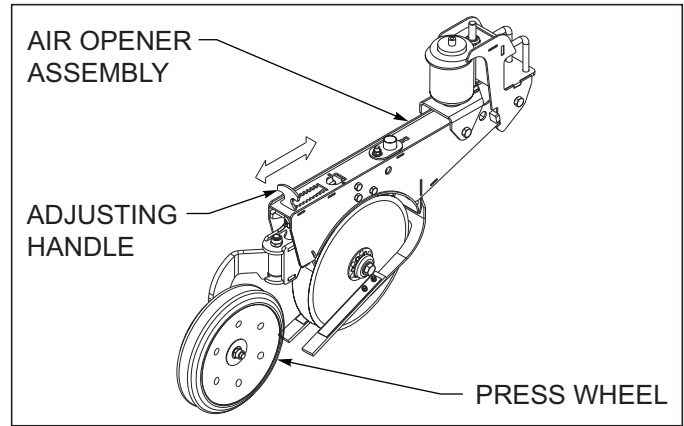

Figure 4-34: Press Wheel Adjustment

Opener Scraper Adjustment

1. The opener is equipped with a scraper to keep the inside surfaces of the opener blades clean. In dryer conditions, the scraper can be adjusted farther away from the opener blades for greater clearance. In wetter conditions, it will be necessary to adjust the scraper blade closer to the opener blade.



CAUTION

Opener blades are very sharp. Use gloves when working around opener blades.

2. To adjust the scraper blade, loosen the 1/2-13 hex flange spirallock nut holding the blade, and slide the blade up or down to achieve the desired clearance **See Figure 4-35**. Re-tighten the 1/2-13 hex flange spirallock nut. Carefully rotate the opener blades to make sure the blades will turn freely and not drag on the scraper.
3. A properly maintained opener blade pinch point will reduce the amount of soil that enters between the opener blades. This will in turn allow the scraper to operate in a cleaner environment and reduce scraper wear.

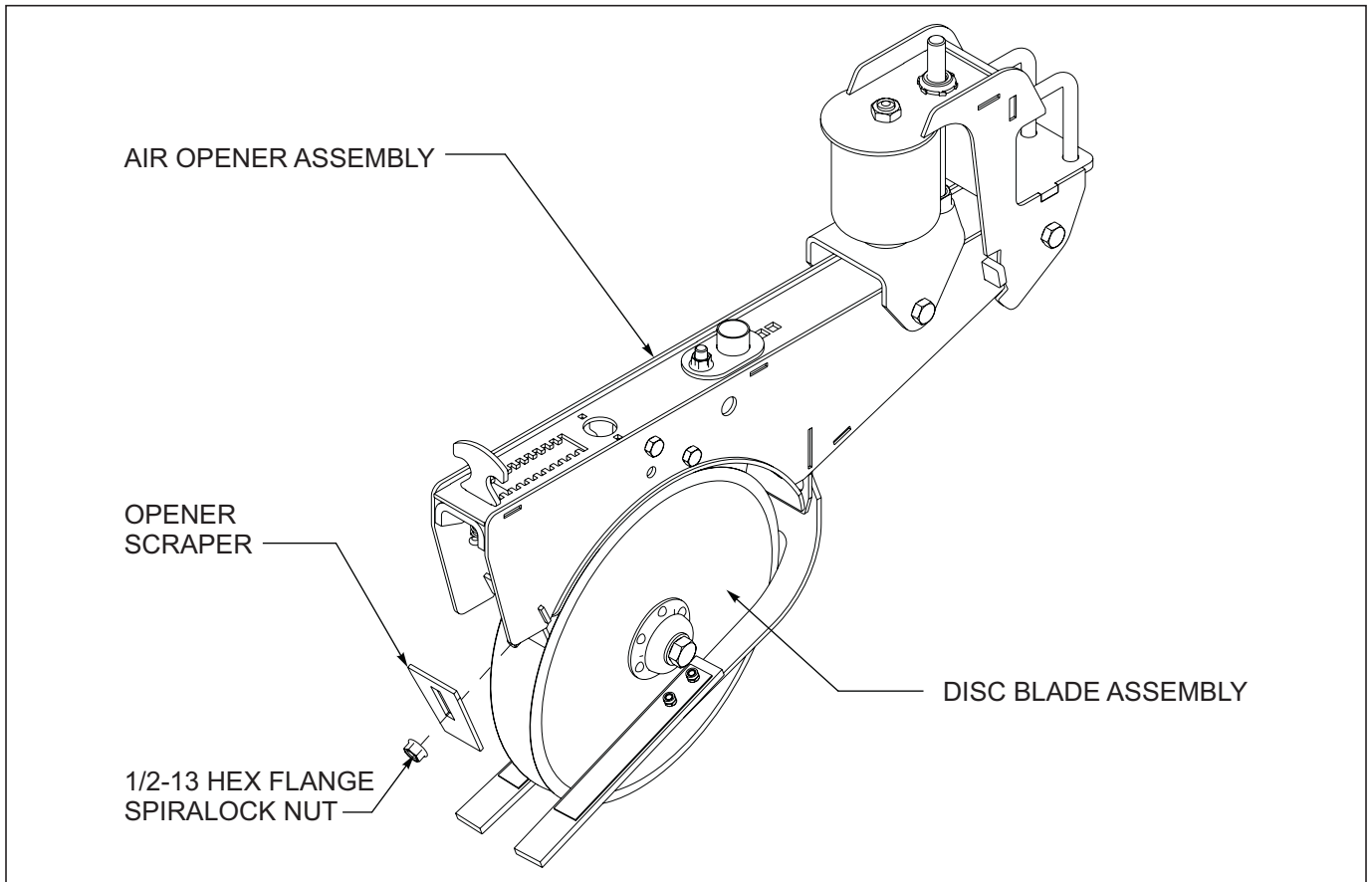

Figure 4-35: Opener Scraper Adjustment

Opener Soil Strip Adjustment

1. The soil strip runs along the side of the opener blade to reduce soil blow out of the seed trench. This will allow the soil to stay in position for more consistent filling of the seed trench and uniform coverage.
2. The opener should first be set for the desired planting depth and press wheel adjustment. The soil strip should then be adjusted for slight pressure with the ground where the opener blade is leaving the seed trench. Excessive down pressure on the soil strip will increase wear and can cause plugging issues. The soil strip should be set to run parallel with the opener with an approximate 1/16" gap. The soil strip should not be set so tight to the opener blade that will drag or prevent the opener blade from turning freely.

3. The metal backing strip should be centered over the soil strip. Do not allow the metal backing strip to rub against the opener blade or it will tend to trap residue.



CAUTION

Opener blades are very sharp. Use gloves when working around opener blades.

4. To adjust the soil strip, loosen the 1/2-13 hex flange spirallock nut at the front of the soil strip bracket *See Figure 4-36*. The bracket may be adjusted up or down to the desired height and side to side to center on the opener blades. Retighten the 1/2-13 hex flange spirallock nut.

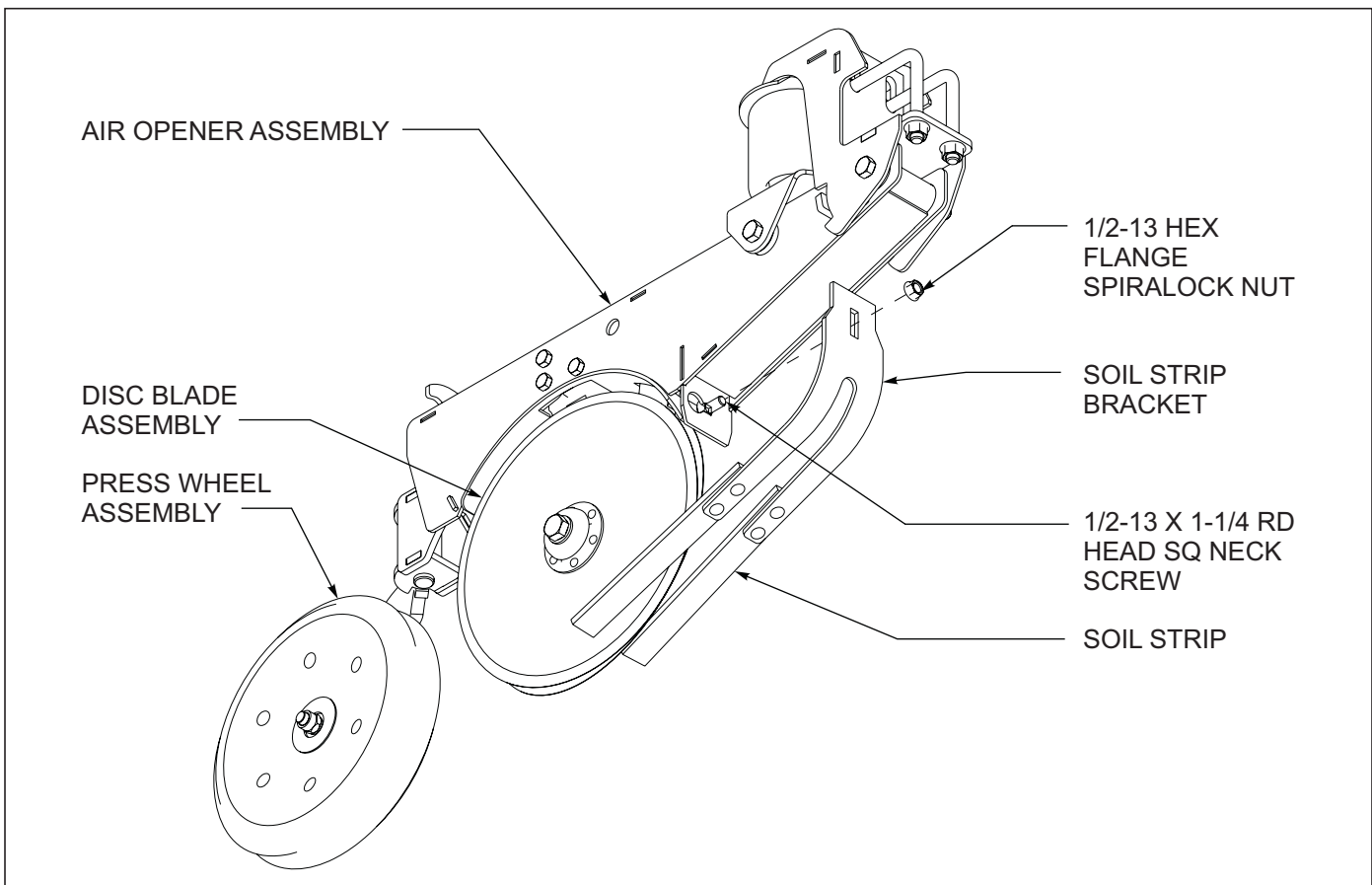

Figure 4-36: Opener Soil Strip Adjustment

Drive Shaft – Coupler Alignment

The center box seed shaft is driven from the drive wheel on the right wing. The drive shaft connects via a coupler when the Grain Drill is unfolded. The drive shaft coupler should be in alignment when the drill is unfolded and in the planting position.

1. To align the coupler, loosen the adjustment bolts A, B, and C **See Figure 4-37**.
2. Loosen any setcrews at the seed transmission bearings on the center section. The center frame drive shaft should now be free to slide side-to-side.
3. Unfold the drill and lower the openers to planting position.
4. Rotate and align the male and female couplers teeth and slide the center drive shaft to the right until the teeth fully engage.
5. Tighten the “A” adjustment bolt and any set screws that were loosened at the seed transmission.
6. Slide the drive shaft bearing mount forward or rearward to align the shaft in that direction and tighten the “B” adjustment bolts.
7. Raise or lower the height of the drive shaft until the coupler is in alignment vertically and tighten the bearing flange bolts “C”.
8. After starting planting operations, check the drive shaft coupler after a short period of actual planting to verify that the drive shafts are still in alignment. If not, adjust as necessary to maintain alignment.

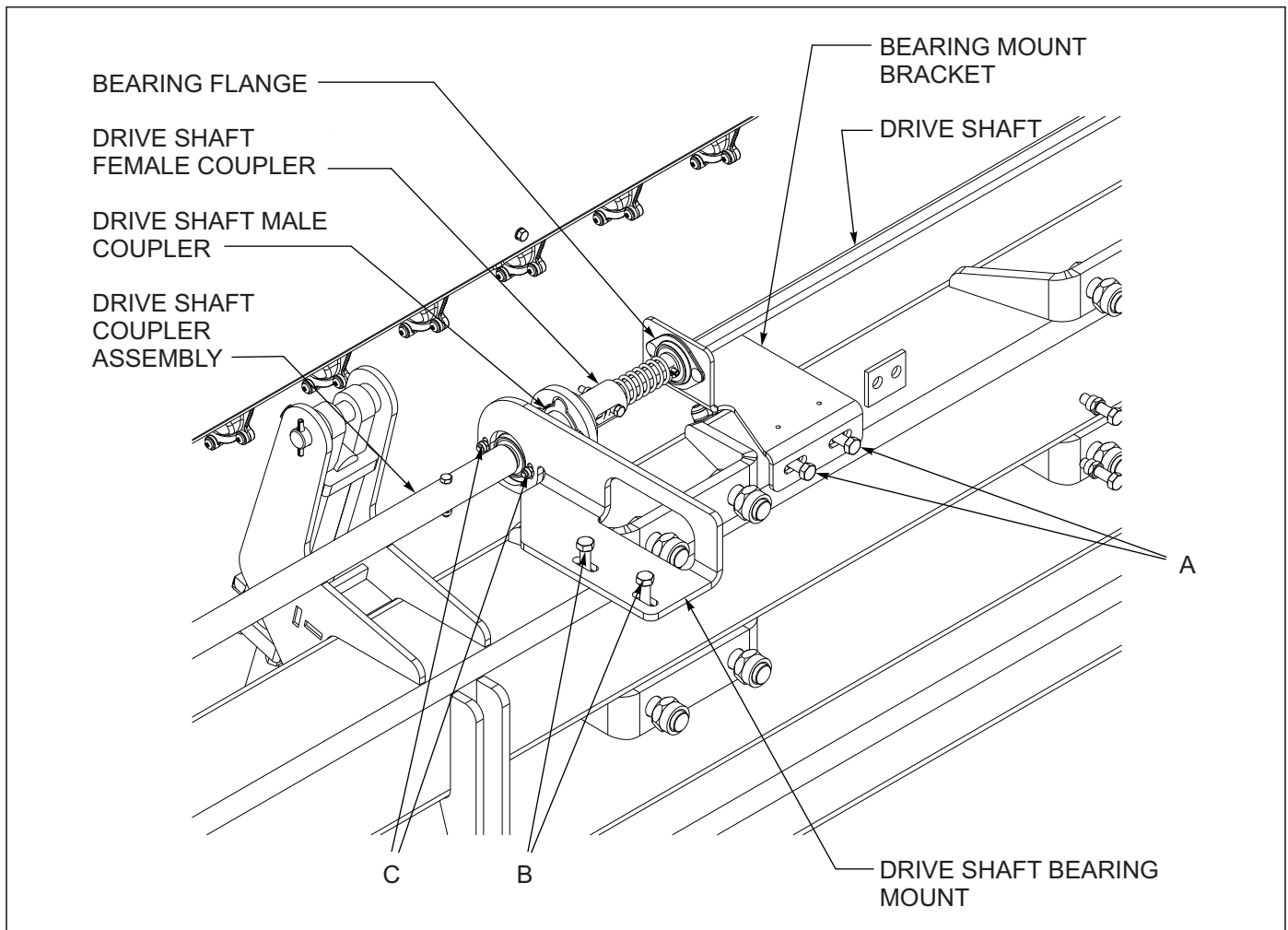

Figure 4-37: Drive Shaft - Coupler Alignment

Walkboard

1. The walkboard on the Grain Drill provides a stable platform to work from while filling the seed box. See [Figure 4-38](#).



WARNING

Do not allow anyone to stand, ride, or climb on the walkboard while the drill is in motion.

2. The walkboard may be raised to allow easier service access to the openers. To raise the walkboard, lift at the center rear of the walkboard and rotate forward. Gas cylinders on each end of the walkboard will assist in raising and lowering the walkboard.
3. To lower the walkboard, stand on the ground behind the walkboard, pull rearward and downward at the center rear of the walkboard and slowly lower to a level position.

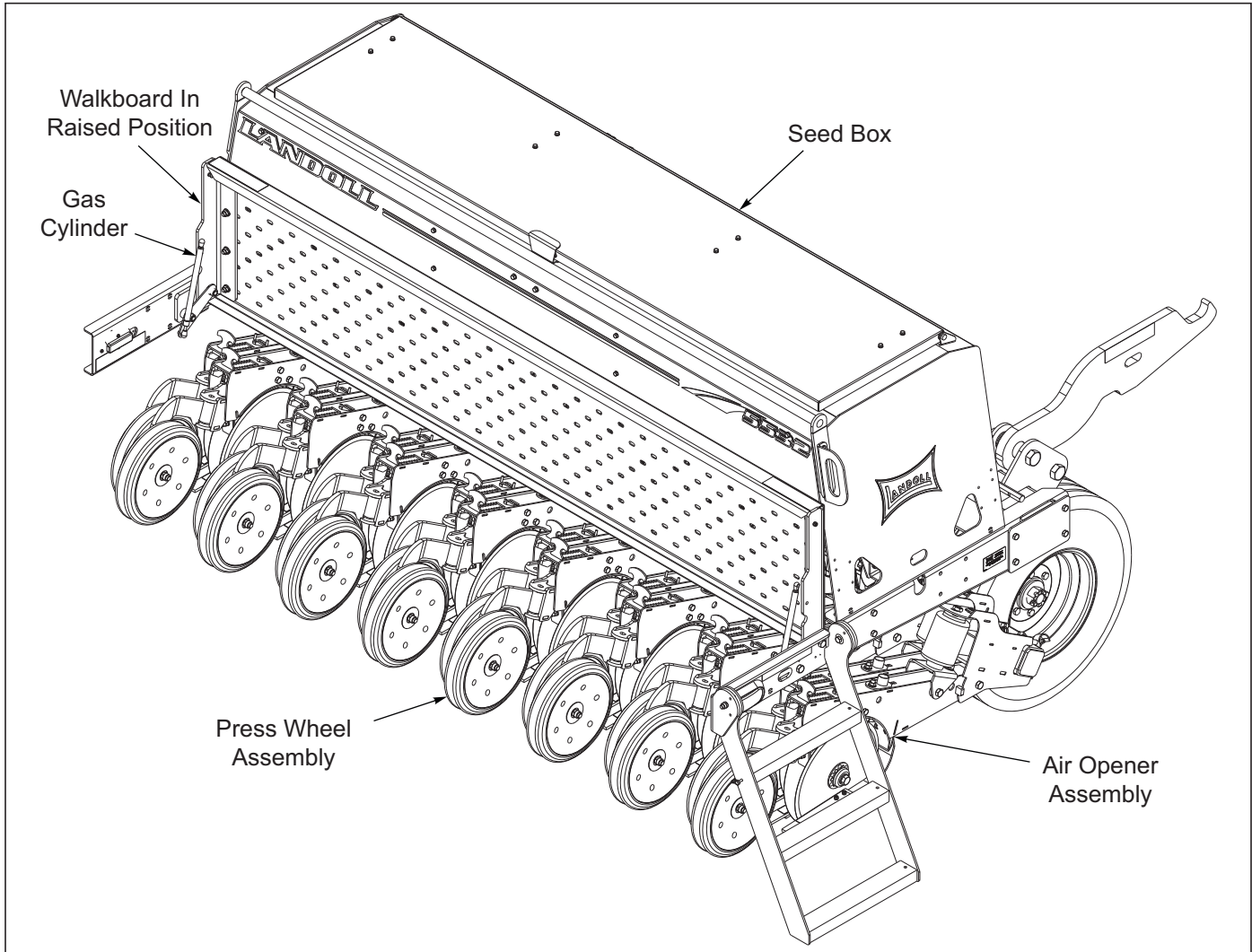

Figure 4-38: Walkboard Adjustment

Ladder Use and Transport Requirements

1. When transporting the 5532 Grain Drill:
 - a. The ladder should be in the raised position (laying across the top of the walkboard) and secured with the pin *See Figure 4-39*.
 - b. The ladder should also be in the raised position when working in the field to prevent damage when working near trees, fences, power lines, etc.
2. When using the ladder:
 - a. Lower ladder to the down position and place pin in the storage location to gain access to the seed boxes *See Figure 4-40*.
 - b. Handles are provided on each end of the drill as well for access.

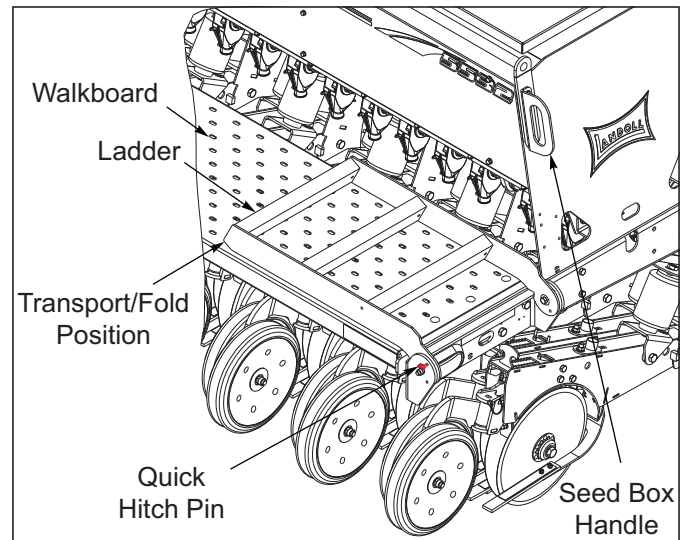

Figure 4-39: Ladder Location During Transport/Planting

 WARNING
<p>Never allow riders on the ladders or walkboards while the drill is in operation or being transported.</p>

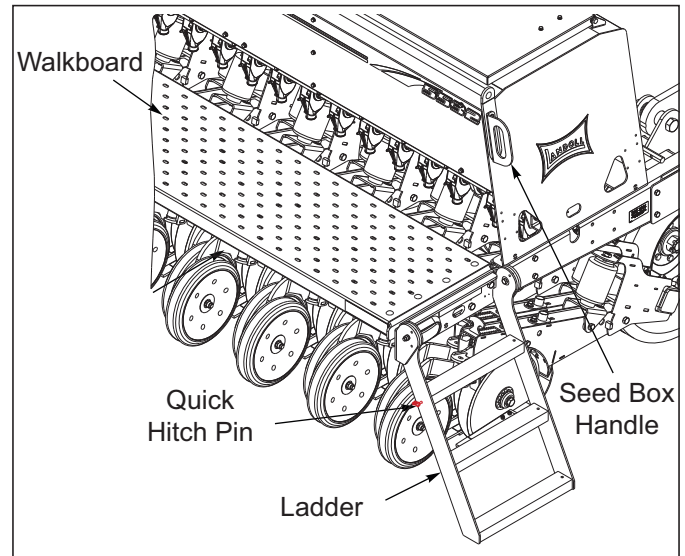

Figure 4-40: Using the Ladder

Hydraulic Row Markers (Option)

1. The Grain Drill may be equipped with optional hydraulic row markers. This will require a fourth tractor remote to operate the markers.



DANGER

To prevent injury or death, stay clear of markers while folding/unfolding. Hydraulic failure can allow markers to raise or fall suddenly.



DANGER

To prevent injury or death from electrocution: stay away from power lines while transporting, folding, or unfolding markers. Electrocution can occur without direct contact of power lines.

2. To operate the markers, unfold the drill so that it is in planting position. Never attempt to fold/unfold the markers with the drill in folded or transport position.

3. With both markers in the raised position, slowly engage the marker hydraulics. One marker will extend. Reversing the hydraulic lever will raise that marker.
4. Slowly engage the marker hydraulics again and the opposite marker will extend.
5. Reverse the marker hydraulics again and that marker will rise.
6. The marker unfold/fold process will then repeat itself.



CAUTION

Marker blades are very sharp, use gloves when working around marker blades.

7. Insure that the marker hydraulic system is full of oil before attempting to fold or unfold the markers. If a hydraulic component is removed, repaired, or replaced the system must be purged of air before folding/unfolding the markers. To purge the system of air, unpin the rod end of both marker cylinders. Align or prop the cylinders into position so that the rod will not interfere with anything during its travel. Slowly engage the tractor hydraulics fully extending and retracting both marker cylinders. Repeat several times until the action of both cylinders is positive and immediately responsive. Do not loosen or crack any fittings. Reconnect the rod end of both cylinders.

Hydraulic Row Marker Disc Adjustment (Option)

! CAUTION

Marker blades are very sharp. Use gloves when working around marker blades.

1. The marker disc blade may be adjusted to vary the mark left in the field.
 - a. The disc angle may be adjusted to leave a wider or narrower cut. The steeper the angle the wider the cut will be *See Figure 4-41*.
 - b. Loosen the 1/2-13 x 3-1/2" round head square neck screws that attach the spindle assembly to the extension tube marker weldment.
 - c. Rotate the marker blade assembly as desired and re-tighten the mounting bolts.
2. The disc blade may also be configured to push or pull soil towards the drill.
 - a. To change the direction of the disc blade, first remove the 4 bolts and dust cap retainer from each hub assembly.
 - a. Remove the two 1/2-13 x 3-1/2" round head square neck screws that attach the spindle assemblies to the extension tubes.
 - b. Swap the spindle and hub assemblies with the right and left markers.
 - c. Using the 1/2-13 x 3-1/2" round head square neck screws, attach the spindle assemblies to the bottom of the extension tubes.
 - d. Change the direction of the marker disc blade and reinstall the 4 mounting bolts and dust cap retainer.
3. To adjust the cutting width of the marker disc, loosen the u-bolt that secures the extension tube to the outer arm assembly.
4. Slide the extension tube in or out to the desired position and retighten the u-bolt.
5. Pull the drill a short distance and verify adjustment.

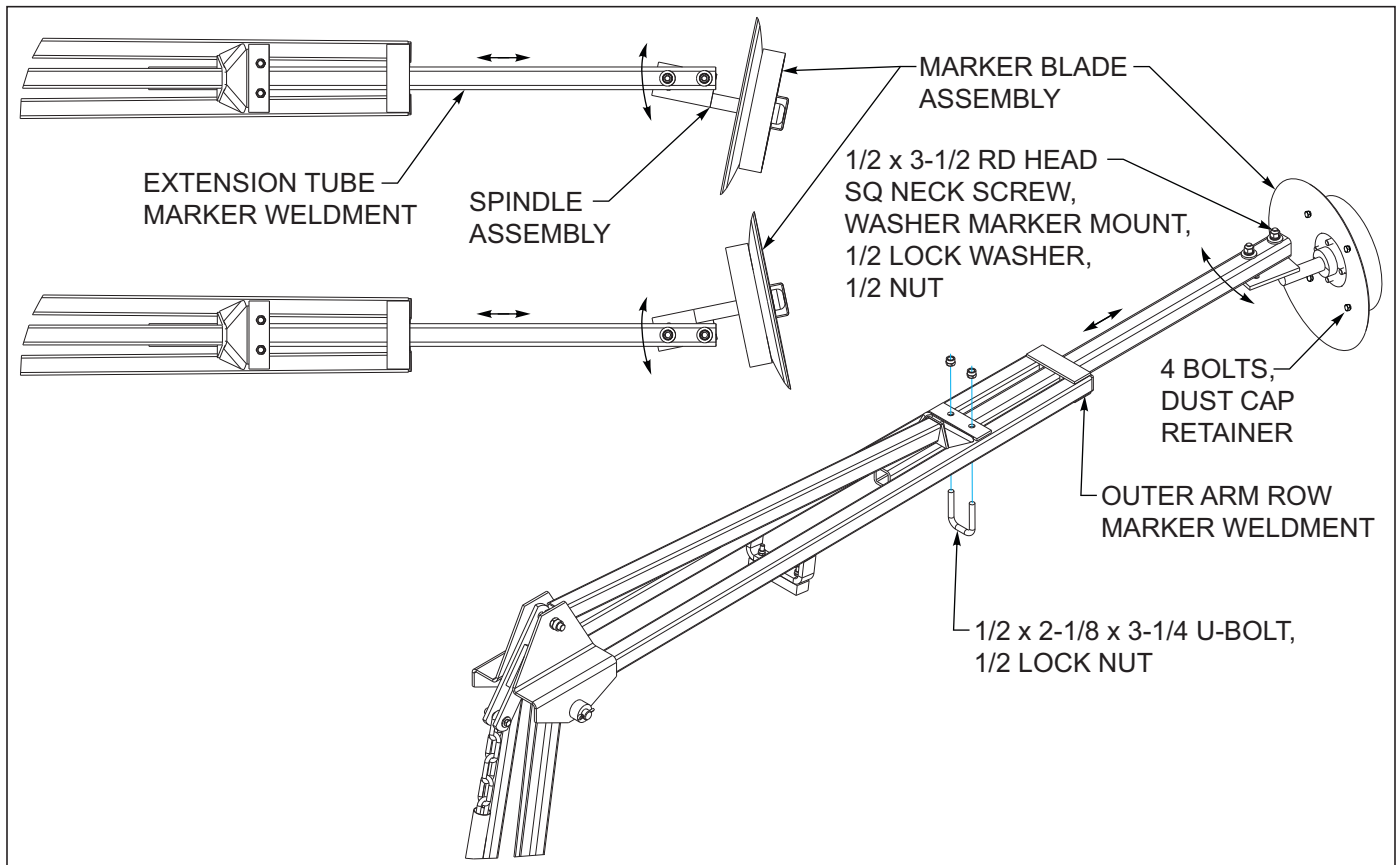

Figure 4-41: Hydraulic Row Marker Adjustment

5532 Point Row Clutch (Option)

The 5532 Grain Drill may be equipped with an optional point row clutch assembly. The clutch assembly allows the operator to turn off seeding of either the center or both wing sections. This allows the operator to drill narrower swaths, reduce over seeding, and conserve seed.

1. A control box is located in the cab with the operator. The control box has three switches, one for each section.
 - a. To engage the clutch, the operator may turn on any or all switches to activate the clutches and stop the seeding of any section(s).
 - b. To resume seeding the operator must turn the switches off for the section(s) to begin seeding.

NOTE

When the center section is turned off, the Loup drill monitor will turn off as well. The speed sensor pickup is located and driven by the center section.

2. The point row clutches are operated from a 12 volt source in the tractor. The clutches use an electric/air solenoid valve to engage clutches. Air is used from the air spring openers to operate the clutches. Although air usage is minimal, the clutches do consume air from the openers, and will occasionally need to add air to the opener system via the system compressor. Leave the air compressor turned on while using point row clutches. This will insure a full supply of system air pressure. Minimum air system pressure will be approximately 30 psi to effectively operate the point row clutches.
3. Connect the control box leads to a 12 volt power source within the tractor that can be controlled by the ignition switch. That will prevent the clutches from being left on and running down the tractor battery when the tractor is turned off.
4. Store the control box inside the cab to protect it from dirt and moisture. The control box may be disconnected at the front of the Grain Drill when unhitching the drill.
5. In the event of power failure to the point row clutch assembly, the mechanical clutches on the drill will still operate. The operator may continue planting, but will not have the ability to turn off the sections.

Maintenance and Lubrication

Wheel Bearing Maintenance – Non Triple-Lip

Transport tires use a self-contained seal with multiple lips. The seal fits tight on both the spindle and wheel hub. The seal when properly installed will rotate internally and freely. This seal will also allow grease to pass when lubricating the hub.

Wheel bearing maintenance should be performed at the beginning of every season of use. Check the wheel bearings periodically for excessive end play. If needed, adjust or replace them using the following procedure:

1. Place the frame on blocks or stands sufficiently to lift the tire clear of the ground.
2. Remove the tire.
3. Remove the dust cap, gasket, cotter pin, slotted nut, and washer.
4. Remove the hub assembly from the spindle. Clean and inspect the bearings and hub cavity. Replace any worn or defective parts.
5. Repack the bearings using a high-quality wheel bearing grease.
6. Install the inner bearing into the hub and install the grease seal. Use a driver to install the seal, to avoid damaging the outer edge of the seal. Drive the seal squarely into the hub to avoid any seal distortion.
7. Slide the hub, bearing, and seal onto a clean spindle.
8. Install the outer bearing, washer, and slotted nut.
9. Tighten the slotted nut while rotating the hub until there is a slight resistance to hub rotation. Then back the slotted nut off one notch, until the hub rotates freely without end play.
10. Install the cotter pin, dust cap and gasket
See Figure 5-1.

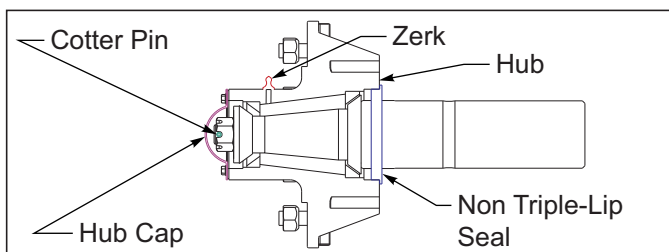

Figure 5-1: Non-Triple Lip-Seal

Hydraulic Maintenance

1. Check the tractor hydraulic fluid level per tractor owner's manual and after any leakage. Check fluid level with the cylinders in the retracted position.
2. If a cylinder or valve leaks, repair it immediately. Any time a cylinder is opened up, or whenever any seal replacement is necessary, it is advisable to clean all parts and replace all seals. Seal kits are available from your Landoll dealer.
3. Check all hydraulic hoses regularly. Look for binding or cracking. Replace all worn or defective parts immediately.

IMPORTANT

Lower the unit to the ground, and relieve hydraulic pressure before attempting to service any hydraulic component.

4. Cylinder locks are provided to hold the implement in a raised position. Do not attempt to perform any service work under the implement without first installing the cylinder locks. Before servicing any hydraulic component, lower the implement to the ground and relieve all system pressure. If a hydraulic component is disconnected, repaired, or replaced, it will be necessary to purge the system of air before operation. *See "Folding/Unfolding the Grain Drill" on page 4-6 and "Hydraulic Lift System" on page 4-14 on how to purge the hydraulic systems.*

Hose Identification

1. The hydraulic hose ends are color coded to help identify and match the attaching hoses on the Grain Drill. An identification decal is placed on the front of the hitch to help identify the hoses *See Figure 5-2.*
2. For the Grain Drill, hose ends will be identified as follows:
 - Blue - Lift Wheels
 - Yellow - Wing Fold
 - Red - Openers
 - Black - Row Markers (Optional)
 - Gray - Rear Tow Hitch (Optional)

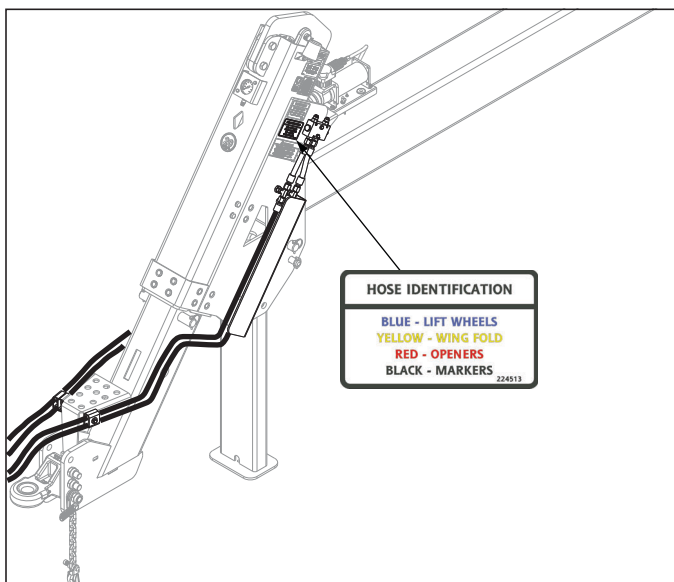

Figure 5-2: Hose Decal

Parking

1. When unhitching the Grain Drill from the tractor, it is best to park in the folded position whenever possible. This gives the drill the smallest storage footprint, and keeps the openers off the ground. Park the drill on a level area to prevent rolling and shifting. If the drill must be parked unfolded, do so only temporarily as hydraulics and air systems may settle.
2. To park the drill with the wings in the folded position:
 - a. Raise the opener bars and install the opener bar lock pins, to prevent setting.
 - b. Fully raise the drill extending the main lift cylinders and the telescoping hitch.
 - c. Lower the front parking jack stand and pin in the parking position. If storing on soft ground, place board/plate under the jack stand for a wider foot print
 - d. Remove the cylinder lock pin from the telescoping hitch and place in the storage position.
 - e. Slowly lower the front telescoping hitch until weight is relieved from the tractor drawbar.
 - f. Install the wing fold lock pin to secure the wings.
 - g. Disconnect the safety chain and wiring.
 - h. Disconnect the hydraulic hoses and place in the storage bracket above the hitch.
 - i. Carefully remove the hitch pin.
3. To park the drill with the wings unfolded:



WARNING

The Grain Drill has negative tongue weight when the boxes are unfolded and openers are raised. Removing the hitch pin in the unfolded position can allow the hitch to raise suddenly causing personnel injury or death.

- a. With the wings unfolded, make sure the main lift and hitch are fully lowered.
- b. Slowly extend the front telescoping hitch but not raise the main lift.
- c. Lower the parking stand and pin in the storage position.
- d. Lower the openers to the ground to support the rear of the drill.
- e. Slowly extend or retract the telescoping hitch to relieve the weight on the tractor drawbar.
- f. Disconnect the safety chain and wiring.
- g. Disconnect the hydraulic hoses and place in the storage bracket above the hitch.
- h. Carefully remove the hitch pin.

Lubrication Maintenance

1. **Table 5-1** specifies the lubrication points and intervals on the 5531 Grain Drill. Proper maintenance of your machine will, under normal operating conditions, help to keep it operating at or near its peak performance for an extended period of time. Proper maintenance is also a condition of keeping your warranty in good status **See Figure 5-3** and **See Figure 5-4**.
2. The drill should be lubricated after initial setup and prior to field operations. When lubricating the Grain Drill, SAE multi-purpose EP grease, or EP grease with 3-5% molybdenum sulfide is recommended. Wipe soil from fittings before greasing. Replace any lost or broken fittings immediately.
3. The Grain Drill is equipped with maintenance-free bearings in the lifts. These areas require no lubrication.

LUBRICATION TABLE			
ITEM	DESCRIPTION	NO. OF LUBE POINTS	INTERVAL (Hours Unless Stated)
1	Drive Shaft Center	1	10
2	Seed Drive Clutch	2 each	10
3	Seed Clutch w/Point Row Option	3 each	10
4	Wing Hinge	1 each	50
5	Inner Wing Pivot	2	50
6	Marker Arm	6	50
7	Marker Hub	2	50
8	Drive Wheel Clutch	2	50

Table 5-1: Lubrication Table

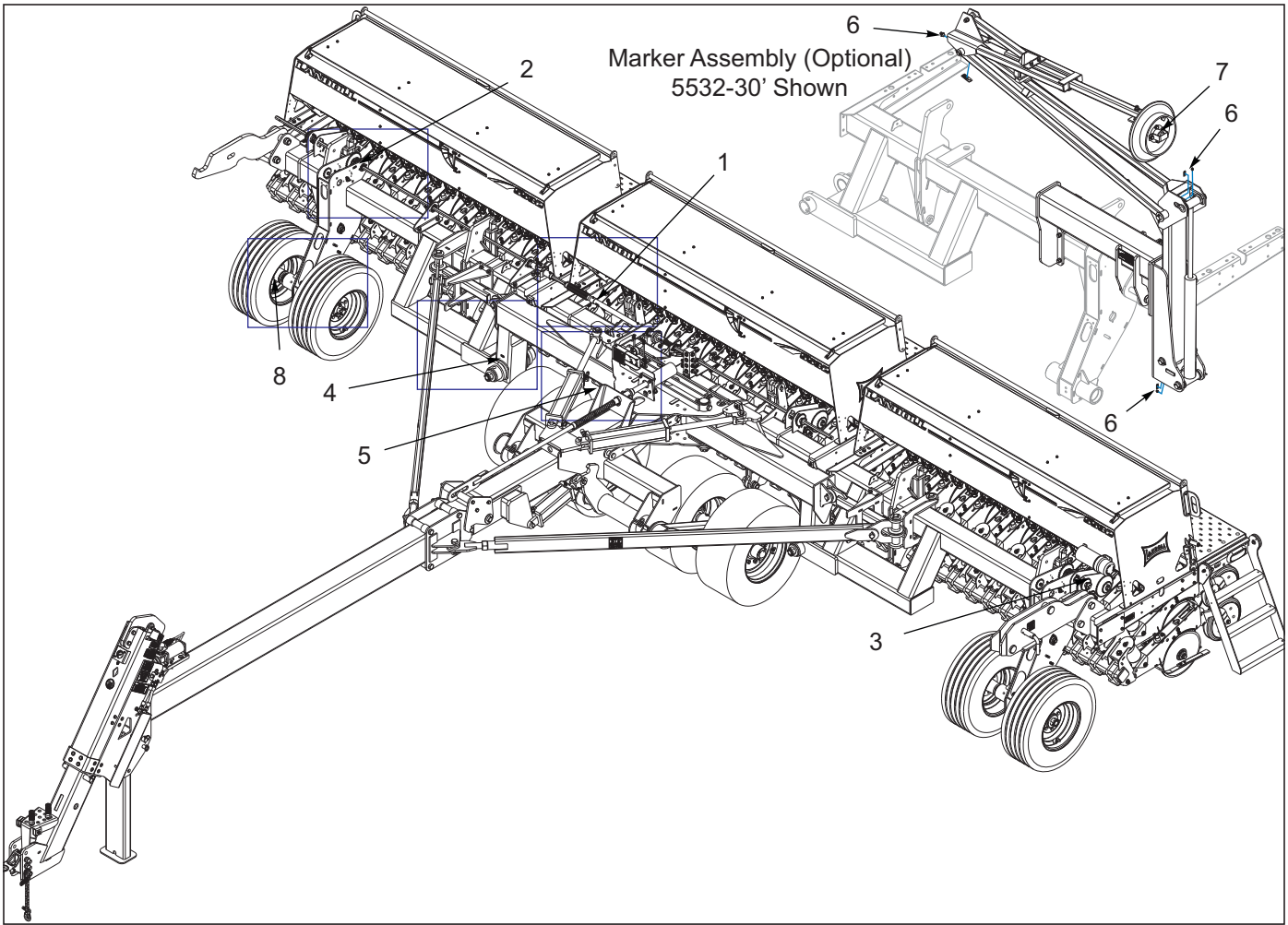

Figure 5-3: Lubrication Points (1 of 2)

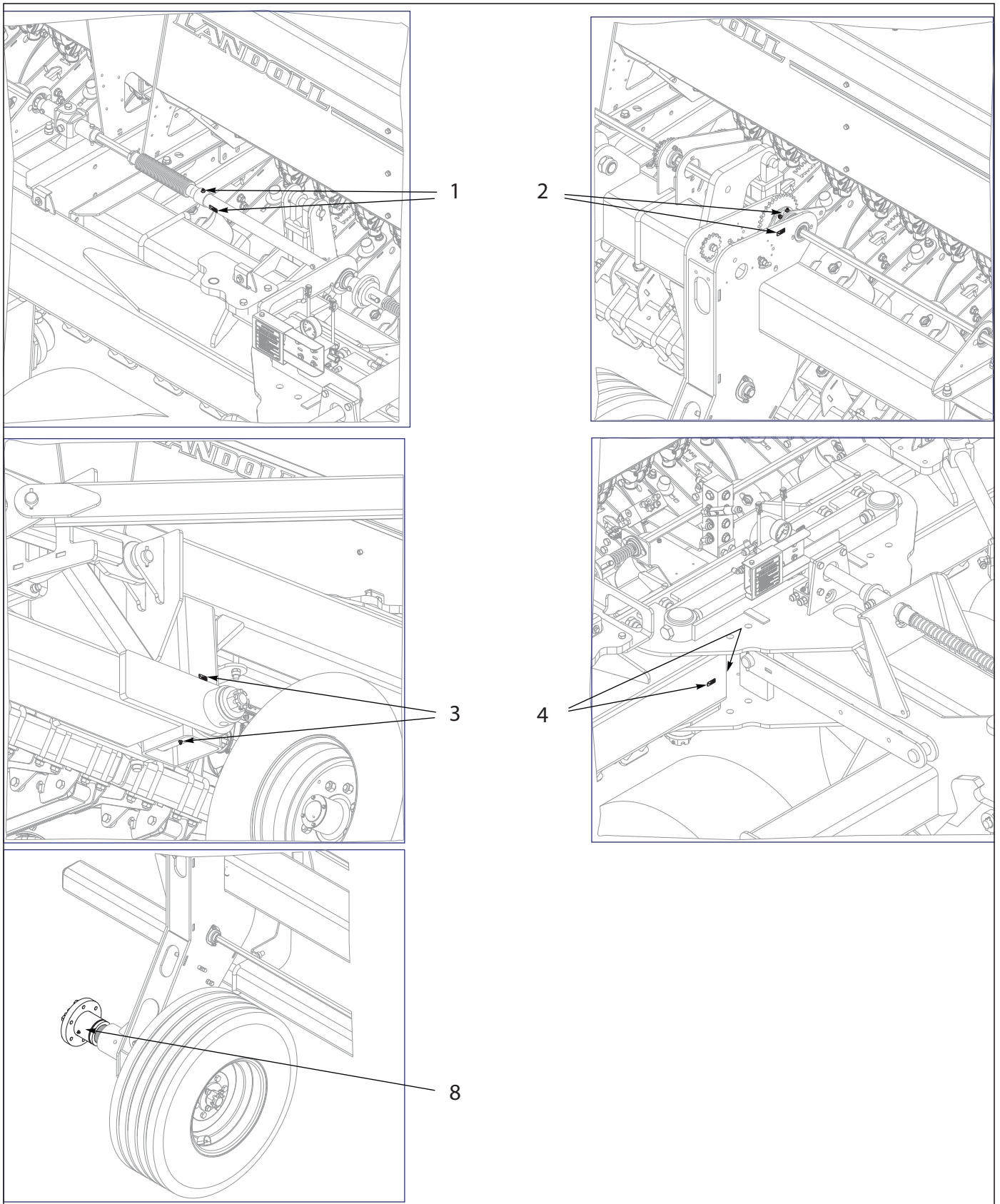

Figure 5-4: Lubrication Points (2 of 2)

Storage

Preparing the Grain Drill for storage during extended periods of time will not only help protect the drill, but insure that it will be maintained, serviced, and ready for the next planting season.

1. Clean out any remaining seed and fertilizer from the boxes and meters before storage. Thoroughly remove and wash out any dry fertilizer.
2. Wash or blow off any remaining dirt, mud or residue from the drill.
3. Inspect the drill for worn or broken parts. Make repairs and service during the off season to prevent delays.
4. Lubricate the drill at all points *See “**Lubrication Maintenance**” on page 5-3.*
5. Check opener pinch point for proper adjustment.
6. Clean and repack the wheel bearings.
7. Inspect all nuts and bolts for tightness.
8. Touch up any scratches or chips with spray paint to protect the metal.
9. Check and inflate tires to the proper air pressure.
10. Maintain air system operating pressure on the openers.
11. Store unit with the openers raised, this will reduce tension on the rubber seed tubes. Raise the openers and install opener bar lock pins in all sections, to prevent settling. If the openers are lowered, disconnect the lower end of the rubber seed tube.
12. Store the drill inside in the folded position if possible. If stored outside, cover with a tarp.

Troubleshooting Guide

The Troubleshooting Guide, shown below, is included to help you quickly locate problems that can happen using your 5532 Grain Drill. Follow all safety precautions stated in the previous sections when making any adjustments to your machine.

PROBLEM	PROBABLE CAUSE	SOLUTION
PLANTING TOO DEEP	Incorrect depth	Adjust press wheel height <i>See “Opener – Press Wheel Adjustment” on page 4-31.</i>
	Excessive down pressure	Reduce air system pressure on row units <i>See “Opener Air Pressure” on page 4-12.</i>
	Drill not level front to rear, hitch too high	Adjust hitch height <i>See “Leveling the Hitch” on page 4-7.</i>
PLANTING TOO SHALLOW	Incorrect depth	Adjust press wheel height <i>See “Opener – Press Wheel Adjustment” on page 4-31.</i>
	Insufficient down pressure	Increase air system pressure on row units <i>See “Opener Air Pressure” on page 4-12.</i>
	Drill not level front to rear, hitch too low	Adjust hitch height <i>See “Leveling the Hitch” on page 4-7.</i>
	Opener cylinders not fully extended	Fully extend cylinders, do not operate cylinders in float position
UNEVEN SEED DEPTH	Row unit depth not set the same	Adjust press wheel height <i>See “Opener – Press Wheel Adjustment” on page 4-31.</i>
	Drill not level front to rear	Adjust hitch height <i>See “Leveling the Hitch” on page 4-7.</i>
	Seed shallow in tire tracks	Adjust press wheel height and increase down pressure (<i>See “Opener Air Pressure” on page 4-12 and “Opener – Press Wheel Adjustment” on page 4-31.</i>)
	Excessive field speed	Reduce field speed.
	Plugged seed tube	Clean seed tube.
	Mud build up between opener blades	Adjust scraper <i>See “Opener Scraper Adjustment” on page 4-32.</i> Adjust blade pinch point <i>See “Opener Blade Adjustment” on page 4-30.</i>
	SECTIONS PLANTING AT DIFFERENT RATES	Seed rate adjustment not the same on all sections
	Drive types (sprocket ratio) not the same on all sections	Change to same drive type on all sections.
	Seed meter out of adjustment	Reset seed meters.
	Opener seed tube plugged	Clean out seed tube.
	Broken seed meter	Allows excessive seeding - repair seed meter.
	Seedbox plugged/Seed bridged	Clean/Agitate seed

TABLE OF CONTENTS

PROBLEM	PROBABLE CAUSE	SOLUTION
UNEVEN SEED SPACING	Excessive field speed	Reduce field speed.
	Unclean seed	Use clean seed
	Build up of seed treatment in seed cup	Clean out seed meters
	Seed tubes sagging	Replace seed tube
	Drive type (sprocket ratio) too slow	Use faster drive type and readjust seed meter opening.
	Plugged opener seed tube	Clean out bottom of seed tube.
OPENER DISCS NOT TURNING FREELY	Opener plugged with mud/dirt	Clean opener.
	Scraper set too tight	Adjust scraper <i>See “Opener Scraper Adjustment” on page 4-32.</i>
	Soil control strip set too tight against opener blades	Adjust soil strip
	Soil strip plugged with residue	Adjust soil strip closer to blade, move metal backing strip away from edge of soil strip <i>See “Opener Soil Strip Adjustment” on page 4-33.</i>
PRESS WHEELS NOT COMPACTING THE SOIL AS DESIRED	Opener down pressure set too low	Increase air system pressure on row units <i>See “Opener Air Pressure” on page 4-12.</i>
	Incorrect press wheel depth adjustment	Reset press wheel depth adjustment <i>See “Opener – Press Wheel Adjustment” on page 4-31.</i>
PRESS WHEEL OR OPENERS PLUGGING	Backed up with openers in the ground	Clean out opener and press wheels and check for damage.
	Scraper worn or not adjusted correctly	Replace or adjust scraper
	Opener blades worn, pinch point too wide	Reset pinch point, replace worn out blades.
	Planting conditions too wet	Wait until drier weather
	Opener bearing failure	Replace opener bearings
AIR SPRING LEAKING AIR	Air spring not set all the way forward or backward in adjustment slots	Replace and reposition air spring
	Operating with too low air pressure	Minimum air system pressure is 15 psi <i>See “Opener Air Pressure” on page 4-12.</i>
	Broken air spring stud	Replace air spring, maximum stud torque 30 ft-lbs.
AIR SYSTEM LEAK - FAST	Broken or pinched air line	Check hitch and wing hinge areas for broken or pinched air line.
	Broken fitting	Repair fitting
	Air line disconnected	Reconnect air line.
	Air spring has hole	Replace air spring.
AIR SYSTEM LEAK - SLOW <i>Use a spray bottle with a soapy water solution to check for the following leaks.</i>	Air leaking thru air compressor filter	Check valve leaking. Replace check valve
	Air line/fitting connection leaking	Air lines ends must be cut square, and not scratched. Recut air line end if necessary. Push-in fitting lock ring when inserting or removing air lines.
	Air relief valve leaking	Clean or replace air relief valve.
	Air manifold leaking	Check front and rear manifolds for leaks.
	Air valve leaking	Tighten/replace Schrader air valve on front manifold.
	End caps on center section opener bar (air reservoir) leaking.	Relieve system air pressure, and repair leaking weld.

Instructions for Ordering Parts

**** Repair parts must be ordered through an Authorized Dealer ****

DEALER INSTRUCTIONS FOR ORDERING PARTS FROM LANDOLL PARTS DISTRIBUTION CENTER

Phone #: 800-423-4320 or 785-562-5381

Fax #: 888-527-3909

Order online: dealer.landoll.com

SERIAL NUMBER PLATE

The Serial Number Plate, which lists the model number and serial number, is located on the front of the hitch
See Figure 7-1.

SERIAL NUMBER NOMENCLATURE

The following information will help decode the 5532 GD serial number

55H2600100 = xxmysssss

The 5532 GD series QR code decal, may be scanned to link to the most current manuals, located on the front of the frame *See Figure 7-1.*

xx	= model series (i.e. 55 for Grain Drill, Fold)
m	= month of manufacture (ex. "H" means October. The letter I is not used.)
yy	= year manufactured (ex. "26" means 2026)
sssss	= Sequential number used to track warranty and service information.

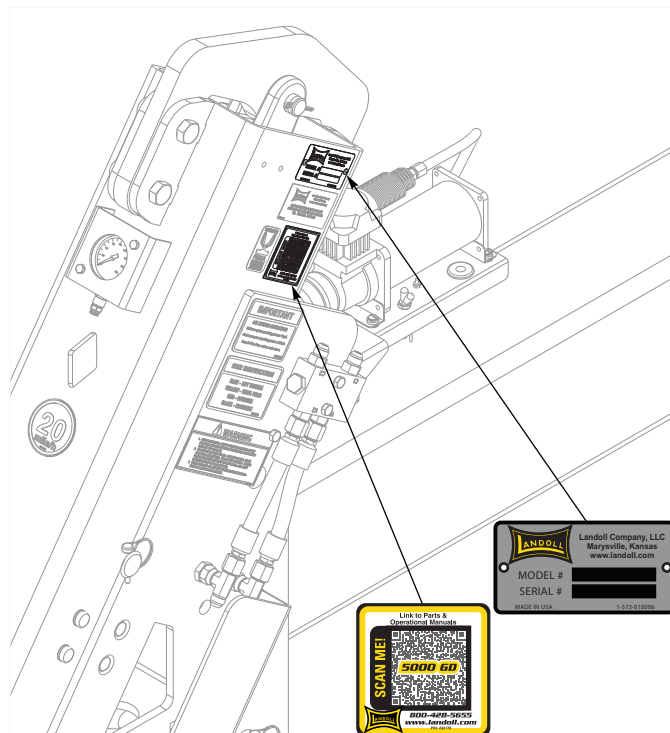

Figure 7-1: Serial Number Plate and QR Code Decal Location

Manuals for 5532 Grain Drill

Manual Number	Manual Type
F-1193	Operator's Manual
F-1194	Parts Manual

Document Control Revision Log:

Date	Form #	Improvement(s): Description and Comments
10/25/2025	F-1193	New Manual
04/02/2026	F-1193-2604	Initial Release
05/18/2026	F-1193-2604	Added small seed and agitator bracket placement



intertek

Equipment from Landoll Company, LLC is built to exacting standards ensured by ISO 9001:2015 registration at all Landoll manufacturing facilities.

Model 5532
Grain Drill
Operator's Manual
Re-Order Part Number F-1193

LANDOLL COMPANY, LLC

1900 North Street

Marysville, Kansas 66508

(785) 562-5381

800-428-5655 ~ WWW.LANDOLL.COM



Copyright 2026. Landoll Company, LLC

“All rights reserved, including the right to reproduce this material or portions thereof in any form.”

